**BEFORE THE
NOVA SCOTIA UTILITIES AND REVIEW BOARD
THE PROVINCE OF NOVA SCOTIA**

**NORTH AMERICAN ELECTRIC)
RELIABILITY CORPORATION)**

**APPLICATION OF THE
NORTH AMERICAN ELECTRIC RELIABILITY CORPORATION
FOR APPROVAL OF PRC-023-1 RELIABILITY STANDARD**

Rick Sergel
President and Chief Executive Officer
David N. Cook
Vice President and General Counsel
North American Electric Reliability
Corporation
116-390 Village Boulevard
Princeton, NJ 08540-5721
(609) 452-8060
(609) 452-9550 – facsimile
david.cook@nerc.net

Rebecca J. Michael
Assistant General Counsel
North American Electric Reliability
Corporation
1120 G Street, N.W.
Suite 990
Washington, D.C. 20005-3801
(202) 393-3998
(202) 393-3955 – facsimile
rebecca.michael@nerc.net

August 4, 2008

TABLE OF CONTENTS

I.	Introduction	1
II.	Notices and Communications	2
III.	Background:	2
	a. Reliability Standards Development Procedure	2
	b. Progress in Improving Proposed Reliability Standards	3
IV.	Justification for Approval of the Proposed Reliability Standard	3
V.	Summary of the Reliability Standard Development Proceedings	25
VI.	Conclusion	38

Exhibit A – Reliability Standard Proposed for Approval

Exhibit B – Standard Drafting Team Roster

Exhibit C – Record of Development of Proposed Reliability Standard
[NOTE: Because of the magnitude of Exhibit C, it is not included with this filing, but will be available upon request.]

Exhibit D – “PRC-023 Reference – Determination and Application of Practical Relaying Loadability Ratings”

I. INTRODUCTION

The North American Electric Reliability Corporation (“NERC”) hereby requests approval of one reliability standard, PRC-023-1 — Transmission Relay Loadability Reliability Standard. This application is the first request by NERC for approval of this proposed Reliability Standard.

On February 12, 2008, the NERC Board of Trustees approved PRC-023-1 reliability standard proposed by NERC. NERC requests approval of the Reliability Standard, to be made effective in accordance with the implementation plan included with the reliability standard. **Exhibit A** to this filing sets forth the proposed reliability standard. **Exhibit B** contains the Standard Drafting Team roster. **Exhibit C** contains the complete development record of the reliability standard. **Exhibit D** contains a reference document, “PRC-023 Reference – Determination and Application of Practical Relaying Loadability Ratings,” prepared to support the implementation of the proposed reliability standard.

NERC is filing this reliability standard with the Federal Energy Regulatory Commission (“FERC”), and is also filing this reliability standard with applicable governmental authorities in Canada.

II. NOTICES AND COMMUNICATIONS

Notices and communications with respect to this filing may be addressed to the following:

Rick Sergel
President and Chief Executive Officer
David N. Cook
Vice President and General Counsel
North American Electric Reliability Corporation
116-390 Village Boulevard
Princeton, NJ 08540-5721
(609) 452-8060
(609) 452-9550 – facsimile
david.cook@nerc.net

Rebecca J. Michael
Assistant General Counsel
North American Electric Reliability
Corporation
1120 G Street, N.W.
Suite 990
Washington, D.C. 20005-3801
(202) 393-3998
(202) 393-3955 – facsimile
rebecca.michael@nerc.net

III. BACKGROUND

a. Reliability Standards Development Procedure

NERC develops reliability standards in accordance with Section 300 (Reliability Standards Development) of its Rules of Procedure and the NERC *Reliability Standards Development Procedure*, which is incorporated into the Rules of Procedure as Appendix 3A.

The development process is open to any person or entity with a legitimate interest in the reliability of the bulk power system. NERC considers the comments of all stakeholders and a vote of stakeholders and the NERC Board of Trustees is required to approve a reliability standard for submission to the Commission.

The proposed reliability standard set out in **Exhibit A** has been developed and approved by industry stakeholders using NERC's *Reliability Standards Development Procedure*, and it was approved by the NERC Board of Trustees on February 12, 2008 for filing with the appropriate governmental authorities.

The proposed reliability standard is accompanied by a document entitled “PRC-023 Reference – Determination and Application of Practical Relaying Loadability Ratings.” This document is set out in **Exhibit D**, and presents the rationale behind the requirements in the proposed reliability standard as well as providing the calculation methodology to assist entities in application of the proposed reliability standard. This reference document is presented for information only and NERC is not requesting action on it.

b. Progress in Improving Proposed Reliability Standards

NERC continues to develop new and revised reliability standards that address the issues NERC identified in its initial filing of proposed reliability standards in April 2006, the concerns noted in the FERC Staff Report issued on May 11, 2006, and the directives FERC included in several orders pertaining to NERC’s reliability standards.¹ NERC has incorporated these activities into its *Reliability Standards Development Plan: 2008-2010* that was submitted on October 11, 2007. The reliability standard proposed for approval is a new reliability standard that addresses a key reliability goal that was not directly subject to Commission or staff review during NERC’s filings of its reliability standards. Further, since the proposed reliability standard is completed and approved, it is not included in NERC’s standards development work plan.

IV. JUSTIFICATION FOR APPROVAL OF PROPOSED RELIABILITY STANDARD

This section summarizes the development of the proposed reliability standard and provides evidence that the proposed reliability standard is just, reasonable, not unduly

¹ *Mandatory Reliability Standards for the Bulk-Power System*, 118 FERC ¶ 61,218, FERC Stats. & Regs. ¶ 31,242 (2007) (“Order No. 693”), *order on reh’g, Mandatory Reliability Standards for the Bulk-Power System*, 120 FERC ¶ 61,053 (“Order No. 693-A”) (2007).

discriminatory or preferential and in the public interest. This section describes the reliability objectives to be achieved by approving the reliability standard. The following section describes the stakeholder ballot results and how key issues were considered and addressed by the standard drafting team.

The complete development record for the proposed reliability standard is available in **Exhibit C**. This record includes the successive drafts of the reliability standard, the implementation plan, the ballot pool and the final ballot results by registered ballot body members, stakeholder comments received during the development of the reliability standard, and how those comments were considered in developing the reliability standard. The standard drafting team roster is provided in **Exhibit B**.

a. Basis and Purpose of PRC-023-1 — Transmission Relay Loadability

The purpose of the standard is to set protective relays so as not to limit transmission loadability or interfere with system operators' ability to protect system reliability. At the same time transmission system protective relays must also be set to reliably detect and protect the electrical network from all fault conditions. The development of the PRC-023-1 — Transmission Relay Loadability Reliability Standard is a significant step toward improving the reliability of the bulk power system in North America because it addresses key August 14, 2003 blackout recommendations² regarding relay loadability issues.

Relay loadability refers to the ability of protective relays to restrain operation for load conditions. As protective relays can respond only to measured voltage and current, they must be set such that they will detect the faults for which they must operate while

² U.S. – Canada Power System Outage Task Force Final Report on the August 14, 2003 Blackout in the United States and Canada: Causes and Recommendations – April 2004; NERC Technical Analysis of the August 14, 2003, Blackout: What Happened, Why, and What Did We Learn? – July 13, 2004.

not operating unnecessarily for non-fault load conditions. This reliability standard requires certain Transmission Owners, Generator Owners and Distribution Providers to set protective relays to prescribed limits for the purpose of protecting systems and ensuring settings do not contribute to cascading outages, and to establish agreements with Planning Coordinators with respect to which transmission lines operated from 100 kV to 200 kV are subject to this new standard. Specifically, the protective relays should detect all fault³ conditions, not limit transmission loadability, thus allowing system operators the flexibility and time to help maintain system reliability.

Relay loadability issues were found to have played a pivotal role in accelerating and spreading the early part of the cascading outage in Ohio and Michigan during the August 14, 2003 blackout, and protective relay issues have exacerbated system disturbances at least since the Northeast Blackout of 1965. During the 2003 blackout, a substantial number of lines tripped due to relay loadability,⁴ many of them before the blackout entered an unrecoverable cascading stage. It is difficult to be certain about the effect that this proposed reliability standard would have had on the end-state of the blackout. Considered in concert with other activities that have been precipitated by the blackout investigation, it seems clear that the events of the blackout would have taken a very different course and that relay loadability would not have been as pivotal a factor as seen on August 14, 2003.

³ A fault is an event occurring on an electric system such as a short circuit, a broken wire, or an intermittent connection.

⁴ Some notable examples of protective relays tripping due in inadequate relay loadability on August 14, 2003 include the Sammis-Star 345 kV line at 16:05:57 hours, and the Argenta-Battle Creek, Argenta-Tompkins, and Battle Creek-Oneida 345 kV lines at 16:10:36 hours. Many other lines also tripped due to similar causes.

This proposed standard specifically addresses Recommendation 8A⁵ approved by the NERC Board of Trustees in February 2004, and the U.S.-Canada Power System Outage Task Force's Recommendation 21A, "Make More Effective and Wider Use of System Protection Measures,"⁶ as included in the U.S.-Canada Power System Outage Task Force's April 2004 final report.

NERC Recommendation 8a specifically states,

All transmission owners shall, no later than September 30, 2004, evaluate the zone 3 relay settings on all transmission lines operating at 230 kV and above for the purpose of verifying that each zone 3 relay is not set to trip on load under extreme emergency conditions[.]. In each case that a zone 3 relay is set so as to trip on load under extreme conditions, the transmission operator shall reset, upgrade, replace, or otherwise mitigate the overreach of those relays as soon as possible and on a priority basis, but no later than December 31, 2005. Upon completing analysis of its application of zone 3 relays, each transmission owner may no later than December 31, 2004 submit justification to NERC for applying zone 3 relays outside of these recommended parameters. The Planning Committee shall review such exceptions to ensure they do not increase the risk of widening a cascading failure of the power system.

U.S. Canada Power System Outage Task Force Recommendation 21a specifically added:

Task Force: Recommends that NERC broaden the review to include operationally significant 115 kV and 138 kV lines, e.g., lines that are part of monitored flowgates or interfaces. Transmission owners should also look for zone 2 relays set to operate line zone 3s.

Although the U.S.-Canada Power System Outage Task Force focused on the role played by "zone 3" relays, it was later discovered that other phase-distance and overcurrent relays also contributed to the cascade. As a result this proposed standard

⁵ "August 14, 2003 Blackout: NERC Actions to Prevent and Mitigate the Impacts of Future Cascading Blackouts."

⁶ "Final Report on the August 14, 2003 Blackout in the United States and Canada: Causes and Recommendation."

extends beyond “zone 3” relays to include these load-responsive relays such as phase-distance and overcurrent relays.

The proposed reliability standard proposes three primary requirements summarized as follows:

R1. Requirement R1 including sub-requirements R1.1 through R1.13 outline criteria to be used for the setting of phase protective relays to prevent the relays from limiting transmission system loadability and remain responsive for all fault conditions. The sub-requirements are specific criterion to be used for certain transmission system configurations, to account for the presence of devices such as series capacitors, or to address thermal circuit capability. These criteria reflect the maximum circuit loading for the various system configurations and permit the relays to be set for optimum protection while carrying that load. Each criterion seeks to balance the need to protect the system while not limiting load carrying capability. These system configurations and conditions dictate which criterion is to be applied.

- The first criterion specifies transmission line relay settings based on the highest seasonal Facility Rating using the 4 hour thermal rating of a transmission line, plus a design margin of 150%.
- The second criterion may used in instances when detailed studies have been performed to establish the highest seasonal Facility Rating based on a 15-minute thermal rating of a transmission line. In these instances, a design margin of 115% is to be used.

- The third criterion may be used where the maximum theoretical power transfer limit across a transmission line reflects the maximum circuit loading capability. R1.3 offers two calculation methods for determining power transfer in cases of zero source impedance and in cases with known source impedances at each end of the transmission line,
- The fourth criterion may be applied where series capacitors are used on long transmission lines to allow increased power transfer. Special consideration must be made in computing the maximum power flow that protective relays must accommodate on series compensated transmission lines.
- The fifth criterion is applicable in cases where the maximum end-of-line three-phase fault current is small relative to the thermal loadability of the conductor. Such cases exist due to some combination of weak sources, long lines and the topology of the transmission system.
- The sixth criterion, R1.6, may be used for system configurations that have generation remote to load busses or the main transmission busses. Under these conditions, the total generation in the remote area may limit the total available current from the area towards the load center.
- The seventh criterion, R1.7, is appropriate for some system configurations that have load centers which are remote from the generation center and where, under no contingency, would there be appreciable current flow from the load centers to the generation center.

- The eighth criterion, R1.8, is applicable to some system configurations that have one or more transmission lines connecting a remote, net importing load center to the rest of the system. Under these conditions, the total load in the remote area is the maximum load flow towards the load center.
- The ninth criterion, R1.9, applies to some system configurations that have one or more transmission lines connecting a cohesive, remote, net importing load center to the rest of the system. Under these conditions, the remote area will be able to supply limited load flow towards the system.
- The tenth criterion, R1.10, is specific to transmission transformer fault protective relays. The transformer fault protective relaying settings are set to protect for fault conditions, not excessive load conditions. These fault protection relays are designed to operate relatively quickly. Loading conditions on the order of magnitude of 150% (50% overload) of the maximum applicable nameplate rating of the transformer can normally be sustained for several minutes without damage or appreciable loss of life to the transformer.
- The eleventh criterion, R1.11, may be used for those situations where the consequence of a transmission transformer tripping due to an overload condition is less than the potential loss of life or possible damage to the transformer. In these cases additional considerations are specified to limit unnecessary tripping due to load.

- The twelfth criterion, R1.12, is useful in cases of long line relay loadability where there are: only two lines; or where there are three or more terminal lines with one or more radial taps. In these cases, the relays must be set to provide minimum protection for a line, and the relay settings will limit the circuit loading capability. This limited circuit loading capability will become the Facility Rating of the circuit.
- The last criterion, R1.13, is intended to apply where otherwise supportable, practical conditions imposed by the previous sub-requirements R1.1 through R1.12 are not suitable. For example, use of zone-3 relays for full backup protection of a particular line in the event of a breaker failure condition may utilize sub-requirement R1.13 to guide the settings. R1.13 can apply provided that extensive planning studies determine that the maximum load (even under Category 4 "Extreme" contingencies from TPL standards – Table 1) with a margin of 115% as specified in sub-requirement R1.13 does not conflict with those relay settings. As noted in R2, the entity must obtain the agreement of the Planning Coordinator, the Reliability Coordinator, and the Transmission Operator with the calculated circuit capability.

R2. Transmission Owners, Generator Owners, and Distribution Providers that use a circuit with phase protective relays settings per Requirements R1.6 through R1.9, R1.12 or R1.13, must calculate the circuit capability according to this requirement and reach agreement regarding the calculated circuit capability with the associated Planning Coordinator, Transmission

Operator, and Reliability Coordinator. Criteria R1.6 through R1.9 pertain to various transmission system configurations such as generation centers that are remote to load centers; load centers that are remote from generation centers; *etc.*, criterion R1.12 deals with long line relay loadability, and R1.13 deals with other circuit limitations not explicitly covered by R1.6 through R1.9 and R1.12. These requirements reflect specific system arrangements that present practical limitations to the maximum available load flow, and usually must be developed via calculation. However, when these practical limitations are used, the drafting team considered that all relevant operating entities must be in agreement that they have been accurately evaluated. When a Transmission Owner, Generator Owner or Distribution Provider selects and applies a circuit capability from any of the criteria listed in Requirement R2, these entities must then designate that circuit capability as the Facility Rating and obtain concurrence from its Planning Coordinator, Transmission Operator and Reliability Coordinator that they will respect that Facility Rating.

- R3. Requirements R1 and R2 are to be applied to all transmission lines operated at 200 kV and above without exception. For lines operated from 100 kV up to 200 kV, Requirement R3 states that Planning Coordinators must designate the lines critical to the reliability of the Bulk Electric System to have Requirements R1 and R2 apply. Further, Requirement R3 states the Planning Coordinator shall have a process to determine which facilities operated between 100 kV and 200 kV are critical to the reliability of the

Bulk Electric System, maintain a list of such facilities and provide the list to its Reliability Coordinators, Transmission Owners, Generator Owners and Distribution Providers within 30 days of the establishment of the initial list and within 30 days of any changes to the list.

Demonstration that the proposed Reliability Standard is just, reasonable, not unduly discriminatory or preferential and in the public interest

The discussion below explains how the proposed reliability standards have met or exceeded the criteria for demonstrating that the proposed Reliability Standard is just, reasonable, not unduly discriminatory or preferential and in the public interest:

1. The proposed Reliability Standard is designed to achieve a specified reliability goal .

Proposed reliability standard PRC-023-01 — Transmission Relay Loadability specifically establishes, within Requirement R1 and its sub-requirements, that protective relay settings, while providing essential facility protection for faults, must not prevent the bulk power system from being operated in accordance with the established Facility Ratings as defined in NERC's Glossary of Terms. The proposed standard also establishes in Requirement R1.12 that in the event an essential fault protection imposes a more-constraining limit on the system, the limit imposed by the fault protection is reflected within the Facility Rating. A transmission system with protective phase relays set in accordance to this proposed Standard will have set the loadability envelope as far as is prudent and optimal. Said another way, relays that are set more conservatively than necessary will not afford system operators the maximum loadability of the transmission system under their control and as a consequence reduces the reaction time window

needlessly. Therefore, the criteria offered in this proposed reliability standard set an appropriate balance between prudent relay application and operator flexibility.

Proposed reliability standard PRC-023-1 interacts with several other NERC reliability standards to address the goal stated above.

- a) NERC reliability standard FAC-008-1 – Facility Ratings Methodology requires that Transmission Owners and Generator Owners have a Facility Ratings methodology. Proposed reliability standard PRC-023-1 establishes in Requirement R1.12 that, when protective relay loadability imposes a limit on the Facility Ratings, the resulting relay loadability is to be reflected in those Facility Ratings.
- b) NERC reliability standard FAC-009-1 – Establish and Communicate Facility Ratings requires that Transmission Owners and Generator Owners establish Facility Ratings for their equipment, and that they provide those ratings to other affected entities.
- c) NERC reliability standard IRO-002-1 – Reliability Coordination – Facilities requires that Reliability Coordinators shall have sufficient monitoring for the system within their Reliability Coordinator area to ensure that potential or actual System Operating Limit or Interconnected Reliability Operating Limits are identified, and that they monitor those elements.
- d) NERC reliability standard IRO-005-1 – Reliability Coordination – Current Day Operations requires that Reliability Coordinators be aware at all times

of the current state of the interconnected system (including all pre-contingency element conditions), be aware of all post-contingency element conditions, and have mitigation plans to alleviate System Operating Limit or Interconnected Reliability Operating Limit violations.

- e) NERC reliability standard TOP-008-1 – Response to Transmission Limit Violations requires that Transmission Operators operate their systems such that System Operating Limit and Interconnected Reliability Operating Limit violations do not occur, and that, if they do occur, take immediate steps to alleviate the conditions causing the violations.

The interactions of the proposed reliability standard PRC-023-1 and the cited standards require that limits shall be established for all system elements, that the interconnected system shall be operated within those limits, that the operators shall take immediate action to mitigate operation outside those limits, and that protective relays (whether zone-3 protective functions or other load-responsive functions) shall not operate until the observed condition on their protected element exceeds those limits. The protective relay margins vary with individual sub-requirements and the various criteria as noted within R1.

2. The proposed Reliability Standard contains a technically sound method to achieve the goal.

The proposed reliability standard contains technically sound methods to achieve the goal. The technical methodology was developed by a large team comprised of protective relaying subject-matter experts, was vetted through the IEEE Power System Relaying Committee (which is an even larger subject-matter-expert group in this area),

and have been validated by over three years of industry application.

The development of this methodology started with the criteria suggested in NERC Recommendation 8a and evaluated conditions where the relay settings limited the operating capability of certain circuits although that limitation was not expressly known by the operators.

Therefore, the proposed standard defines specific technical criteria for a variety of configurations and circumstances that direct the minimum acceptable thresholds for relay settings so as not to impede the full operating capability of the circuit. Where circumstances indicate that a relay setting must necessarily limit the operation of the equipment, this limitation must be noted for consideration in the facility rating methodology.

After NERC's System Protection and Control Task Force ("SPCTF") developed the initial methodology for circuits 200 kV and above (zone-3 relays only), the methodology was applied to 10,914 total circuit terminals across North America, whereupon it was determined that 1,855 of those terminals required modification in order to conform to the criteria. After the methodology was enhanced to address other load-responsive relays other than zone 3, an additional 11,499 circuit terminals were reviewed, and 2,293 of those required modification. At this time, all of the terminals requiring modification as a result of the initial review have been addressed, and the vast majority of the terminals requiring modification due to the second-phase review have also been addressed.

Additionally, the proposed standard is rooted in part from lessons learned from investigations into many actual operating incidents based on the goal to minimize future contribution of protective relaying to system events.

3. The proposed Reliability Standard is applicable to users, owners, and operators of the bulk power system, and not others.

The proposed reliability standard is applicable to users, owners and operators of the bulk power system, and not others. The entities include Transmission Owners, Generator Owners, Distribution Providers and Planning Coordinators that are users, owners and operators of the bulk power system.

NERC's SPCTF and the PRC-023 Standard Drafting Team recognized that the definition of "Bulk Electric System," varies throughout the eight Regional Entities. The SPCTF and the drafting team both concluded that this proposed reliability standard should be voltage-level-specific, as opposed to being generically applicable to the bulk electric system. This conclusion was reached by considering the potential variances in the facilities included as the bulk power system in different Regional Entities, together with an observation that the effects of the proposed reliability standard are not constrained to Regional boundaries. For example, if one Region has a purely performance-based criteria and an adjoining Region has a voltage-based criteria, these criteria may not permit consideration of the effects of protective relay operation in one Region upon the behavior of facilities in the adjoining Region.

On this issue, the standard drafting team also considered that the unilateral imposition of these requirements upon all 100 kV and above circuits, as suggested by the NERC general definition of the Bulk Electric System and by the definitions of several of the Regional Entities, would establish an increase of the implementation costs by

approximately two orders of magnitude above those endemic in the proposed standard as drafted, and that this cost increase would distract financial, analytical and staffing resources from other areas with a higher effect on reliability. Subjecting such circuits to this Standard (absent determination of criticality as established in the requirements) would have little additional benefit to the reliability of the interconnected system.

The standard drafting team, when considering these factors, decided that the system applicability should be to all 200 kV and above circuits, and those lower voltage level circuits that are specifically determined to be critical to the reliability of the bulk electric system.

4. The proposed Reliability Standard is clear and unambiguous as to what is required and who is required to comply.

The proposed reliability standard is clear and unambiguous as to what is required and who is required to comply. Each requirement clearly states what applicable entities are required to do. Within the reliability standard, Requirement R1 requires that each relevant entity with Bulk Electric System equipment as defined in the applicability section shall maintain reliable protection and shall also set each of their protective relays according to one of the criteria established in the sub-requirements to Requirement R1. Requirement R2 establishes that, if a criterion pertains to a limitation other than the thermal rating of the specific circuit, the Planning Coordinator, Transmission Operator and Reliability Coordinator shall agree with the circuit capability used, and that that circuit capability shall be used as the Facility Rating of the circuit. Requirement R3 establishes that the Planning Coordinator shall have a methodology to determine “critical” 100-200 kV circuits, that they shall maintain a list of circuits determined using

that methodology, and that they shall provide the list to the relevant entities for application of Requirement R1.

All the requirements provide additional specificity regarding the setting of protective relays as related to various practical circuit capabilities. Those requirements which refer to study-based system conditions, rather than established Facility Ratings, require that system flows be carefully evaluated by the wide-area operating entities (Reliability Coordinators), local area operating entities (Transmission Operator) and wide-area planning entities (Planning Coordinators) to assure that no flow which the interconnected system can withstand, will result in protective relay operation due to load currents encroaching the active reach of a load-responsive relay, and that those entities agree with those conditions.

5. The proposed Reliability Standard includes clear and understandable consequences and a range of penalties (monetary and/or non-monetary) for a violation.

The proposed reliability standard includes clear and understandable consequences and a range of penalties for a violation. Each primary requirement is assigned a Violation Risk Factor and the standard includes Violation Severity Levels that contain detailed descriptions of noncompliance for each requirement that correspond to the Lower, Moderate, High and Severe assignments as described in the Sanction Guidelines. These elements will support the determination of an initial value range for the Base Penalty Amount regarding violations of requirements in the standards, as defined in the ERO Sanction Guidelines.

Requirement R1 is assigned a High Violation Risk Factor in accordance with the definition set forth in the ERO Sanction Guidelines where non-compliance of the

requirement can “directly cause or contribute... to a cascading sequence of failures....”

The assignment of a Medium Violation Risk Factor to Requirements R2 and R3 reflect the lesser probability of impact to the bulk power system resulting from non-compliance.

6. The proposed Reliability Standard identifies clear and objective criterion or measure for compliance, so that it can be enforced in a consistent and non-preferential manner.

The proposed reliability standard identifies clear and objective criterion or measures for compliance, so that that the standard can be enforced in a consistent and non-preferential manner. Each requirement clearly states mathematical formulas for transmission relay settings, required agreements, and a process for and the identification of critical assets with respect to transmission relay loadability such that the respective applicable entities know what is required to achieve the reliability objective. The simplest example may be found in R1.1, which states “Set transmission line relays so they do not operate at or below 150% of the highest seasonal Facility Rating of a circuit, for the available defined loading duration nearest 4 hours (expressed in amperes).” All other R1 sub-requirements have similarly specific requirements which relate to the practical circuit capability represented in the sub-requirement. The measures clearly correspond to each required settings, agreement and facility process and identifications for their respective requirements such that each requirement can clearly and consistently be enforced without prejudice to any party. The three measures are included in Section C of the proposed reliability standard.

Furthermore, to aid in the compliance monitoring process, NERC will develop a reliability standard audit worksheet (“RSAW”) for this reliability standard if the standard is included in the list of actively monitored reliability standards for a particular program

year. As these RSAWs are guides for compliance auditors, they may also assist the entity in understanding what they are expected to provide in support of the particular measures to demonstrate compliance.

7. The proposed Reliability Standard achieves a reliability goal effectively and efficiently.

The proposed reliability standard achieves its reliability goal effectively and efficiently, without necessarily having to reflect “best practices” without regard to implementation costs. In many cases, entities may comply with the proposed reliability standard by using long-established calculation methods that have been applied to legacy equipment, and therefore the proposed standard does not require the use of the latest available technology, nor does it require the use of any evolving best-practice evaluation methods.

In many cases, the calculation methods will determine whether legacy equipment can be adjusted to meet the proposed reliability standard. In some cases, however, recent advancements in protective relay technology will be needed to satisfy the requirements of the proposed reliability standard and also provide effective fault protection for the relevant system element. For example, the protection of circuits above 200 kV is considerably demanding of the most sophisticated protective relays; therefore, it is customary that most modern protective relays are applied to circuits above 200 kV. Lower voltage circuits usually require less-sophisticated protective relays to satisfy the protective criteria; thus, the applied relays do not require and thus may not have the advanced capabilities noted above. Additionally, communications-based relaying, which can detect faults over the entire length of a circuit as well as provide communications-

based backup protection (rather than backup protection based on overreaching distance relays) is much more common at 200 kV and above, and the substation bus arrangements at 200 kV and above diminish the need for relaying at remote locations that will detect faults in the event of protective equipment failure. These factors all contributed to the decision to limit universal applicability to circuits 200 kV and above, and to make the reliability standard applicable only to 100-200 kV circuits that are “critical” to the reliability of the bulk power system.

8. The proposed Reliability Standard is not a “lowest common denominator,” and does not reflect a compromise that fails to adequately protect bulk power system reliability.

The proposed reliability standard is not a “lowest common denominator,” and does not reflect a compromise that fails to adequately protect bulk power system reliability. The proposed standard establishes a first-ever, challenging threshold through a set of minimum requirements that will considerably advance the formalization of preventative settings and operations of protective equipment. This will serve the important reliability goal of minimizing the contribution of protective relays to future system events. While these requirements are “minimum” requirements, they have been determined by careful analysis of Facility Ratings, and by review of practical System Operating Limits to establish base thresholds not in existence heretofore, and carefully balance those thresholds with the need to provide effective fault protection for the affected circuits.

Relay loadability has commonly played a significant role in system disturbances including the 1965 blackout and the August 2003 blackout. As a result of the NERC

SPCTF-directed program, relay loadability has been a much lesser factor on the list of contributory factors for North American disturbances since August 2005.

Only two instances of relay loadability have been noted in event analyses since the relay loadability review was conducted: one was on a lower voltage transmission circuit that was not subject to the loadability review; and the other was on a circuit that had been scheduled for loadability mitigation in response to the relay loadability review program, but had not yet been corrected. The latter occurred during a contingency that impacted two large sister nuclear units that were each isolated to single 230 kV lines. One unit tripped on instability, but stability analysis showed that the second unit would not have tripped had the line not tripped due to relay loadability issues. The remote-end phase overcurrent relays were set below what the line would have to carry as a single outlet for the unit. Those relays had previously been determined to require setting changes to conform to the relay loadability review recommendations, but work was not scheduled until later in the year of the event. If the changes to the settings had been completed, the line would likely not have tripped and the second nuclear unit would not have tripped or experienced a loss of off-site power

9. The proposed Reliability Standard considers costs to implement for smaller entities but not at consequence of less than excellence in operating system reliability

The proposed reliability standard has considered costs to implement for smaller entities, but not at consequence of less than excellence in operating system reliability. Implementation costs related to the proposed reliability standard will be directly proportional to the amount of relevant facilities owned by the applicable entity. A smaller entity that owns, for example, 10 pertinent circuits will have far lower

(approximately proportional) implementation costs that another that may own 100 or 1000 pertinent circuits. Further, entities that operate lower voltage bulk power system components below 200 kV are not held to the standard unless the facilities are determined to be critical to reliability.

10. The proposed Reliability Standard is designed to apply throughout North America to the maximum extent achievable with a single Reliability Standard while not favoring one area or approach.

The proposed reliability standard is designed to apply throughout North America to the maximum extent achievable with a single reliability standard while not favoring one area or approach. The standard as drafted proposes no Regional differences or variances.

11. The proposed Reliability Standard causes no undue negative effect on competition or restriction of the grid.

The proposed reliability standard should cause no undue negative effect on competition or restrict the grid beyond that which is necessary for reliability, making it acceptable in regards to this factor. In some cases, this proposed standard actually serves to remove arbitrary relay limitations that cause transmission capability limitations. With the exception of those relays that legitimately define and therefore restrict the facility rating, this standard removes capricious limits related to relay loadability. Further, no market-based entity is required to comply with this standard.

12. The implementation time for the proposed Reliability Standard is reasonable.

The implementation plan for the proposed reliability standard indicates that the reliability standard is to become effective the first day of the quarter no sooner than fifteen months after regulatory approval by FERC. NERC believes this presents a

reasonable time frame to allow all entities to be in compliance. The technical requirements of this standard have been implemented by most applicable entities starting in January 2005 under voluntary activities directed by the NERC Planning Committee. Most entities have provided assurances to NERC that they have implemented these technical requirements. The implementation period established in the Implementation Plan provides an opportunity for those entities which did not participate in the voluntary activities to comply with the proposed reliability standard, and for all entities to establish the documentation necessary to demonstrate compliance.

13. The Reliability Standard development process is open and fair.

NERC develops reliability standards in accordance with Section 300 (Reliability Standards Development) of its Rules of Procedure and the NERC *Reliability Standards Development Procedure*, which was incorporated into the Rules of Procedure as Appendix 3A. The development process is open to any person or entity with a legitimate interest in the reliability of the bulk power system. NERC considers the comments of all stakeholders and a vote of stakeholders and the NERC Board of Trustees is required to approve a reliability standard for submission to the appropriate governmental authorities.

The proposed reliability standard set out in **Exhibit A** has been developed and approved by industry stakeholders using NERC's *Reliability Standards Development Procedure*, and was approved by the NERC Board of Trustees on February 12, 2008 for filing with the Commission. Therefore, NERC has utilized its standard development process in good faith and in a manner that is open and fair.

14. The proposed Reliability Standard balances with other vital public interests.

The proposed reliability standard establishes a technical balance between established Facility Ratings and protective relay performance. No environmental, social, or other goals are reflected, nor do they enter into consideration, apart from ensuring the reliability of the grid through removal of unnecessary limitations on grid performance due to load-responsive relays.

V. SUMMARY OF THE RELIABILITY STANDARD DEVELOPMENT PROCEEDINGS

a. Development History

On January 9, 2006, the NERC SPCTF submitted a Standards Authorization Request (“SAR”) to address the cascading transmission outages that occurred in the August 2003 blackout when backup distance and phase⁷ protective relays operated on high line loading and low voltage without electrical faults on the protected lines. The SAR addresses in part a key NERC recommendation from the 2003 Blackout, “Improve System Protection to Slow or Limit the Spread of Future Cascading Outages,” which underscores the culpable role of relay loadability in that disturbance. Similarly, the U.S.-Canada Power System Analysis Task Force referred to the impact of relay loadability upon major transmission system disturbances in its August 2003 Blackout report recommendation 21a (JTF 21a). In March 2004, the NERC Planning Committee

⁷ The original NERC and U.S. Canada Power System Outage Task Force recommendations referred to “Zone 3” and “Zone 2” relays, which are specifically relays which respond to calculated impedance, which equates to distance. The proposed Reliability Standard also acknowledges that other “phase” relays respond to load conditions. In contrast, “ground” relays respond only to unbalanced conditions which are indicative of ground fault conditions, and do not respond to load conditions.

assembled a SPCTF to focus on zone 3⁸ relays, their merits, deficiencies, current usage, setting parameters and to recommend relay protection design improvements in the prevention and mitigation of cascading failures.

The SAR was posted for a 30-day comment from January 16, 2006 through February 15, 2006. There were 17 sets of comments, including comments from 64 different people from 41 companies representing 6 of the 10 industry segments in the Registered Ballot Body. A technical reference document prepared by the SPCTF included the analytical work that underpinned the SAR and was posted with the standard. All comments were addressed and the SAR was modified in response to the comments. The drafting team posted its consideration of the comments on April 26, 2006.

On May 12, 2006, the Standards Committee authorized advancing the SAR to standards development. The standard drafting team consisted of 11 members with system protection engineering, transmission planning or transmission system consulting backgrounds. Drafting team members represent the interests of the large transmission owners, distribution provider organizations, and ISO/RTOs. Three successive versions of the draft standard were posted for public comment, resulting in a final draft that proceeded to the balloting stage.

Draft 1: NERC posted the initial draft of the proposed standard for a 45-day comment period from August 16, 2006 through September 29, 2006. NERC received 36 sets of comments from more than 100 different persons representing over 50 companies

⁸ “Zone 3” relays refer to impedance, or distance, relays which are set to respond to fault conditions well beyond the remote end of the line, and which do so without requiring communications from the remote terminal. These relays are considered to be those most responsive to load conditions.

from 6 of 10 segments. The team modified the standard in response to comments on the initial draft and posted its Consideration of Comments report⁹ January 9, 2007.

Draft 2: NERC posted the second draft of the proposed standard for a 30-day comment period from January 9 through February 7, 2007. There were 22 sets of comments, including comments of more than 93 different people from more than 66 companies representing 9 of the 10 Industry Segments. The team modified the standard in response to these comments and posted its Consideration of Comments report¹⁰ March 9, 2007.

Draft 3: NERC posted the third draft of the proposed standard for a 30-day comment period from March 19 through April 17, 2007. There were 14 sets of comments, including comments of more than 49 different people from more than 40 companies representing 8 of the 10 Industry Segments. The drafting team modified the standard in response to these comments as well.

In addition to stakeholder comments received on the third draft, FERC staff met with NERC staff and some members of the drafting team in May 2007 to informally discuss the proposed reliability standard. As a result of this meeting and subsequent discussion with FERC staff, NERC requested the drafting team to consider several issues to include in the drafted standard. As there was no established process for consideration of FERC staff input apart from the reliability standards development process, NERC's Standards Committee directed that if the drafting team did determine that it wished to make changes as a result of this input, the team would be required to present the modified standard for a minimum 30-day industry comment period. In doing so, the Standards

⁹ See Exhibit C item # 17.

¹⁰ See Exhibit C item # 26.

Committee agreed that consideration of this input was valuable to achieving a favorable outcome when the proposed standard was ultimately filed for approval. The drafting team met and discussed observations of FERC staff, and made certain changes to the standard, discussed in the *Key Issues* section below. However, the team did not consider the changes made to be significant and thus did not request that the drafted standard be publicly posted for comment.

All the comments and the team's consideration of these comments were incorporated into a revised Consideration of Comments report to the third posting of the standard.¹¹ On October 11, 2007 the Standard authorized advancing the standard to balloting. The summary of the balloting stage of the proposed standard follow.

Pre-Ballot Review: After the drafting team considered and responded to the comments received during the third public comment period, NERC posted the final draft of the proposed standard for a 30-day pre-ballot review from October 18, 2007 through November 19, 2007.

First Ballot: The initial ballot of the drafted standard was conducted from November 19, 2007 through December 4, 2007. During the first ballot, 91.83% of those registered for the ballot pool voted, which exceeded the minimum 75% quorum required to be a valid vote. The proposed reliability standard received a weighted segment approval of 80.84%. However, there were 37 negative ballots submitted with 23 of those negative ballots submitting a comment, triggering the need for a recirculation ballot.

Some commenters raised issue with regard to the threshold used to define the applicability of facilities subject to the requirements in this standard. Most stakeholders agreed with the applicability of the proposed standard. The standard drafting team

¹¹ See Exhibit C item # 34.

acknowledged that the threshold may not be unanimously supported, while asserting it is an acceptable “starting point” for the application of this new set of requirements.

Several commenters suggested that the word, “critical” should not be used in the standard. The standard drafting team deliberately avoided capitalizing the word, “critical” in PRC-023-1 to avoid confusing Requirement R3 in PRC-023 with requirements in the Critical Infrastructure Protection series of standards that do use the NERC-defined term, “Critical Asset.” When a word is not capitalized in a NERC standard, the word is not a NERC-defined term and has the same meaning as that found in any collegiate dictionary.

In addition, several typographical and editorial changes were made to the standard in response to the initial ballot comments; however, the changes did not alter the technical content of the standard nor did they change the content or intent of any of the requirements or compliance elements of the standard.

Recirculation Ballot: After the standard drafting team responded to the comments, the proposed reliability standard proceeded to a recirculation ballot that was conducted from January 31, 2008 through February 9, 2008. The proposed reliability standard passed with a final quorum of 93.27% and a weighted segment approval of 82.64%. A two-thirds weighted segment approval is required for passage. On February 12, 2008, the NERC Board of Trustees adopted the proposed reliability standard.

b. Key Issues

During the development of the proposed reliability standard, the standard drafting team considered several key issues that are discussed in this section: i) the scope of the

proposed standard, ii) implementation dates, iii) incorporating FERC comments, iv) bulk power system definition, and v) applicability of Requirement R3 and field testing.

i) THE SCOPE OF THE PROPOSED STANDARD

A technical reference document was initially developed by subject matter experts in response to the NERC Blackout Recommendation 8a and the Blackout Task Force Recommendation 21A. The technical reference document titled, “PRC-023 Reference — Determination and Application of Practical Relaying Loadability Ratings” was posted with the SAR during the 30-day comment from January 16, 2006 through February 15, 2006. The document includes the analytical work that underpinned the SAR and provided explanatory text and supplemental material. The work scope as contained in the SAR for this project was formed on the basis of the technical reference document. The subsequent technical scope of this standard was refined through the stakeholder comment process provided during SAR development, standard drafting, and ballot comment periods.

The purpose of the reference document is to aid entities in understanding the requirements within PRC-023-1. This reference document is not intended to present additional requirements and should not be construed to do so, even though some of the text may appear to be prescriptive. In accordance with the *Reliability Standards Development Procedure*, reference documents may explain or facilitate implementation of a standard but do not contain mandatory requirements subject to compliance review.

ii) IMPLEMENTATION DATES

Some commenters stated that the proposed effective dates were overly ambitious. There are, however, current ongoing activities, under the approval of the NERC Planning

Committee, which essentially direct responsible entities to conform to the requirements of this standard. The due dates for these activities were December 31, 2007 for circuits at 200 kV and above, and June 30, 2008 for 100–200 kV applicable circuits. The proposed effective dates for this standard reflect these ongoing activities. A review of the industry responses to the ongoing activities indicates that most, if not all, affected responsible entities have already performed the bulk of the work needed to comply with the proposed Standard and therefore, the comments offered lacked a sufficient basis.

iii) INCORPORATING FERC COMMENTS

In addition to stakeholder comments for the third draft of the proposed standard, FERC staff invited NERC and the drafting team to an informal meeting to discuss the Standard. A subgroup of the larger drafting team, along with members of NERC staff, presented an overview and technical highlights of the proposed Standard in May 2007.

Shortly after the presentation meeting, FERC staff indicated there were additional points of clarification and explanation desired and suggested changes were brought forward to the drafting team for consideration. Following the closing of the then-open comment period, the drafting team met and discussed observations of FERC staff, and made the following changes to the standard, either in support of the observations, to improve the clarity of the standard, or to better support the compliance program:

- Revised the purpose statement to include stronger emphasis on the reliability objective behind this standard.
- To simplify compliance enforcement, revised the proposed effective dates to ensure that all requirements become effective on the first day of a calendar quarter and to reflect that in some jurisdictions, the approval of a

standard is tied to Board of Trustees' adoption and not a separate regulatory approval.

- Inserted the phrase “load-responsive” into Sections A.4.1, A.4.2 and A.4.3 of the proposed standard for clarification.
- FERC expressed a concern that 15-minute ratings may be used that are not completely reflected as Facility Ratings. The drafting team modified the second footnote to clarify that Requirement R1.2 references 15-minute ratings where such ratings have been calculated and are used for real-time operations.
- Added a third footnote to Requirement R1.11 to reference the IEEE standard that supports the requirement.
- In the third comment posting, Requirement R4 contained a combination of requirement language and implementation plan language, that is, it expressed both an implementation schedule for compliance with Requirement R1 for the initial “critical” 100-200 kV circuits, and also established a requirement for when the responsible entity would be required to be in compliance for additional circuits added to the list. The text related to implementation schedules was entirely relocated to Section 5, Effective Dates in the standard.
- Replaced the term Regional Entity with Compliance Enforcement Authority in Section D.
- Modified the Violation Severity Levels to include a reference to the associated requirement.

In addition, FERC staff offered additional observations that were fully considered by the drafting team and NERC, but were not included in the balloted standard. These issues are discussed below.

Generator step-up (“GSU”) transformer relay loadability was intentionally omitted from PRC-023. GSU relay loadability merits particular attention in the area of generator protection, and as such, it would be inappropriate to include in a transmission relay loadability standard without consideration of the overall generator protective systems in place. It is imperative that GSU protection settings be coordinated with other generator protection functions as well as the associated local transmission system protection. That includes careful consideration of the transient, sub-transient, and steady state generator responses to system conditions, and how the resultant loadings on the GSU must be considered in loadability. Further, from a process perspective, the standard drafting team did not have the requisite technical expertise from representatives from the generator industry segment on the team. Therefore, additional members would need to be identified and added, and then given time to develop the generator protection requirements which would have delayed the presentation of the proposed standard by at least six months. In lieu of delaying a quality standard pertaining to the transmission relay loadability, NERC elected to push forward with this proposed standard and address generator protection standards for relay loadability in future development efforts.

The NERC SPCTF is working closely with the IEEE Power System Relay Committee (“PSRC”) and its rotating machinery subcommittee to prepare the necessary technical basis for a separate generation protection standard. Once the technical

foundation is developed, GSU relay loadability will be then included in a future standards development activity. NERC expects that this effort will begin in 2009.

FERC staff questioned whether zone 3 relays should be available for use on the Bulk Power System at all. On this matter, the proposed reliability standard is silent. The proposed reliability standard establishes requirements for any load-responsive relay on the applicable system elements, regardless of the protective functions being served. The SPCTF paper, “Rationale for the Use of Local and Remote (Zone 3) Protective Relaying Backup Systems, *A Report on the Implications and Uses of Zone 3 Relays*,” addresses the advantages, disadvantages and appropriate application of Zone 3 Relays at length.

FERC staff also indicated a desire for the proposed standard to address the issue of power swings that encroach on the load-responsive relay operational zone.

To consider the concerns about responsiveness of protective relays to power swings, it is necessary to consider the relative time frames of system swings and faults, and to consider that this standard addresses the issues of loadability during a time frame when lines are overloaded and operators can take action. In the August 2003 blackout, the power swing time frame was too short a time frame in which an operator could have taken action, and this is typical for severe power swings. In the electrical vicinity of severe power swings, they are indistinguishable from faults, and it is clear that the relays must respond for faults.

iv) BULK ELECTRIC SYSTEM DEFINITION

Comments throughout development identified an issue related to the use of the term bulk electric system. The NERC Glossary of Term defines Bulk Electric System (bulk electric system) as follows: “(a)s defined by the Regional Reliability Organization,

the electrical generation resources, transmission lines, interconnections with neighboring systems, and associated equipment, generally operated at voltages of 100 kV or higher. Radial transmission facilities serving only load with one transmission source are generally not included in this definition.” This definition clearly allows for Regional variations in the definition of bulk electric system, potentially among neighboring regions. NERC’s recommendations from the investigation into the August 13, 2003 blackout, which provided the genesis for the work preceding the development of this proposed reliability standard, addressed relay loadability requirements for “transmission lines operating at 230 kV and above” (NERC Recommendation 8A) and later recommended in the Blackout Task Force report that “NERC broaden the review to include operationally significant 115 kV and 138 kV lines” (US-Canada Power System Outage Task Force Blackout Task Force Recommendation 21A). By specifically referring to voltage levels in the recommendations, these reports implicitly recognized that system response across the Eastern Interconnection was indifferent to the variations in the definition of the Bulk Electric System. The SPCTF initially, and later the standard drafting team, considered that the blackout recommendations did not align precisely with the various definitions of Bulk Electric System and deferred to the approach detailed in the blackout recommendations. There were numerous stakeholder comments related to this issue.

The SPCTF (initially) and the drafting team both concluded that this proposed reliability standard should be voltage-level-specific, as opposed to being generically applicable to the bulk power system. This conclusion was reached by considering the potential variances in the facilities included as the bulk power system in different

Regional Entities, together with an observation that the effects of the proposed reliability standard are not constrained to regional boundaries. For example, if one Region has a purely performance-based criteria and an adjoining Region has a voltage-based criteria, these criteria may not permit consideration of the effects of protective relay operation in one Region upon the behavior of facilities in the adjoining Region.

On this issue, the standard drafting team also considered that the unilateral imposition of these requirements upon all 100 kV and above circuits, as suggested by the NERC definition, would establish an increase of the implementation costs by approximately two orders of magnitude above those endemic in the draft Standard, and that this cost increase would distract financial, analytical and staffing resources from other areas with a higher effect on reliability. Subjecting such circuits to this Standard (absent determination of criticality as established in the requirements) would have little benefit to the reliability of the interconnected system.

The drafting team, when considering these factors, decided that the system applicability should be to all 200 kV and above circuits, and those lower-voltage-level circuits that are specifically determined to be critical to the reliability of the bulk power system. Although this position was consistent throughout the development of the proposed reliability standard, several commenters consistently offered comments opposing the established applicability, and suggested that the applicability should be limited to the circuits that are specifically determined to be critical to the reliability of the bulk electric system, regardless of voltage. It is recognized that the enforceability of this proposed standard is statutorily limited to such circuits as are also included in the definition of Bulk Electric System.

vi) APPLICABILITY FOR REQUIREMENT R3 AND FIELD TESTING

Based on the foregoing decision, the standard drafting team needed to identify which NERC functional entity was best suited to determine which circuits are critical to the reliability of the bulk power system below the 200 kV threshold. Because the Regional Entity is not a user, owner or operator of the bulk power system, the team could not assign requirements to them although they had served that role in the voluntary era of reliability standards. The drafting team carefully reviewed NERC's Functional Model and determined that the Planning Coordinator intended to have the wide-area view for the planning time horizon. As a result, the responsibility for determining the facilities critical to bulk power system reliability was assigned accordingly. Several drafts of the proposed standard were posted for comment with this assignment, and industry consensus appears to support this assignment.

Once the decision was made to assign responsibility for lower-voltage level critical circuits to the Planning Coordinator, the team then needed to determine whether field testing was needed, such that the function could be implemented by the Planning Coordinator as envisioned by the team. Commenters were split on the issue of whether field testing for the Planning Coordinator was needed. The need for field testing of this standard was evaluated by NERC's Compliance staff, by the Regional Entity Compliance Managers and by stakeholders. There was no consensus on the need for a field test and on October 11, 2007 the Standards Committee authorized moving the standard forward to ballot without a field test.

VI. CONCLUSION

NERC requests approval of PRC-023-1 — Transmission Relay Loadability, as set out in **Exhibit A**. NERC requests that PRC-023-1 — Transmission Relay Loadability be made effective in accordance with the implementation plan provided with the reliability standard.

Rick Sergel
President and Chief Executive Officer
David N. Cook
Vice President and General Counsel
North American Electric Reliability Corporation
116-390 Village Boulevard
Princeton, NJ 08540-5721
(609) 452-8060
(609) 452-9550 – facsimile
david.cook@nerc.net

Respectfully submitted,

/s/ Rebecca J. Michael
Rebecca J. Michael
Assistant General Counsel
North American Electric Reliability
Corporation
1120 G Street, N.W.
Suite 990
Washington, D.C. 20005-3801
(202) 393-3998
(202) 393-3955 – facsimile
rebecca.michael@nerc.net

Exhibit A

Reliability Standard PRC-023-1 submitted for approval

A. Introduction

1. Title: Transmission Relay Loadability

2. Number: PRC-023-1

3. Purpose: Protective relay settings shall not limit transmission loadability; not interfere with system operators' ability to take remedial action to protect system reliability and; be set to reliably detect all fault conditions and protect the electrical network from these faults.

4. Applicability:

4.1. Transmission Owners with load-responsive phase protection systems as described in Attachment A, applied to facilities defined below:

4.1.1 Transmission lines operated at 200 kV and above.

4.1.2 Transmission lines operated at 100 kV to 200 kV as designated by the Planning Coordinator as critical to the reliability of the Bulk Electric System.

4.1.3 Transformers with low voltage terminals connected at 200 kV and above.

4.1.4 Transformers with low voltage terminals connected at 100 kV to 200 kV as designated by the Planning Coordinator as critical to the reliability of the Bulk Electric System.

4.2. Generator Owners with load-responsive phase protection systems as described in Attachment A, applied to facilities defined in 4.1.1 through 4.1.4.

4.3. Distribution Providers with load-responsive phase protection systems as described in Attachment A, applied according to facilities defined in 4.1.1 through 4.1.4., provided that those facilities have bi-directional flow capabilities.

4.4. Planning Coordinators.

5. Effective Dates¹:

5.1. Requirement 1, Requirement 2:

5.1.1 For circuits described in 4.1.1 and 4.1.3 above (except for switch-on-to-fault schemes) —the beginning of the first calendar quarter following applicable regulatory approvals.

5.1.2 For circuits described in 4.1.2 and 4.1.4 above (including switch-on-to-fault schemes) — at the beginning of the first calendar quarter 39 months following applicable regulatory approvals.

5.1.3 Each Transmission Owner, Generator Owner, and Distribution Provider shall have 24 months after being notified by its Planning Coordinator pursuant to R3.3 to comply with R1 (including all sub-requirements) for each facility that is added to the Planning Coordinator's critical facilities list determined pursuant to R3.1.

5.2. Requirement 3: 18 months following applicable regulatory approvals.

¹ Temporary Exceptions that have already been approved by the NERC Planning Committee via the NERC System Protection and Control Task Force prior to the approval of this standard shall not result in either findings of non-compliance or sanctions if all of the following apply: (1) the approved requests for Temporary Exceptions include a mitigation plan (including schedule) to come into full compliance, and (2) the non-conforming relay settings are mitigated according to the approved mitigation plan.

B. Requirements

- R1.** Each Transmission Owner, Generator Owner, and Distribution Provider shall use any one of the following criteria (R1.1 through R1.13) for any specific circuit terminal to prevent its phase protective relay settings from limiting transmission system loadability while maintaining reliable protection of the Bulk Electric System for all fault conditions. Each Transmission Owner, Generator Owner, and Distribution Provider shall evaluate relay loadability at 0.85 per unit voltage and a power factor angle of 30 degrees: [Violation Risk Factor: High] [Mitigation Time Horizon: Long Term Planning].
- R1.1.** Set transmission line relays so they do not operate at or below 150% of the highest seasonal Facility Rating of a circuit, for the available defined loading duration nearest 4 hours (expressed in amperes).
- R1.2.** Set transmission line relays so they do not operate at or below 115% of the highest seasonal 15-minute Facility Rating² of a circuit (expressed in amperes).
- R1.3.** Set transmission line relays so they do not operate at or below 115% of the maximum theoretical power transfer capability (using a 90-degree angle between the sending-end and receiving-end voltages and either reactance or complex impedance) of the circuit (expressed in amperes) using one of the following to perform the power transfer calculation:
- R1.3.1.** An infinite source (zero source impedance) with a 1.00 per unit bus voltage at each end of the line.
- R1.3.2.** An impedance at each end of the line, which reflects the actual system source impedance with a 1.05 per unit voltage behind each source impedance.
- R1.4.** Set transmission line relays on series compensated transmission lines so they do not operate at or below the maximum power transfer capability of the line, determined as the greater of:
- 115% of the highest emergency rating of the series capacitor.
 - 115% of the maximum power transfer capability of the circuit (expressed in amperes), calculated in accordance with R1.3, using the full line inductive reactance.
- R1.5.** Set transmission line relays on weak source systems so they do not operate at or below 170% of the maximum end-of-line three-phase fault magnitude (expressed in amperes).
- R1.6.** Set transmission line relays applied on transmission lines connected to generation stations remote to load so they do not operate at or below 230% of the aggregated generation nameplate capability.
- R1.7.** Set transmission line relays applied at the load center terminal, remote from generation stations, so they do not operate at or below 115% of the maximum current flow from the load to the generation source under any system configuration.

² When a 15-minute rating has been calculated and published for use in real-time operations, the 15-minute rating can be used to establish the loadability requirement for the protective relays.

- R1.8.** Set transmission line relays applied on the bulk system-end of transmission lines that serve load remote to the system so they do not operate at or below 115% of the maximum current flow from the system to the load under any system configuration.
- R1.9.** Set transmission line relays applied on the load-end of transmission lines that serve load remote to the bulk system so they do not operate at or below 115% of the maximum current flow from the load to the system under any system configuration.
- R1.10.** Set transformer fault protection relays and transmission line relays on transmission lines terminated only with a transformer so that they do not operate at or below the greater of:
- 150% of the applicable maximum transformer nameplate rating (expressed in amperes), including the forced cooled ratings corresponding to all installed supplemental cooling equipment.
 - 115% of the highest operator established emergency transformer rating.
- R1.11.** For transformer overload protection relays that do not comply with R1.10 set the relays according to one of the following:
- Set the relays to allow the transformer to be operated at an overload level of at least 150% of the maximum applicable nameplate rating, or 115% of the highest operator established emergency transformer rating, whichever is greater. The protection must allow this overload for at least 15 minutes to allow for the operator to take controlled action to relieve the overload.
 - Install supervision for the relays using either a top oil or simulated winding hot spot temperature element. The setting should be no less than 100° C for the top oil or 140° C for the winding hot spot temperature³.
- R1.12.** When the desired transmission line capability is limited by the requirement to adequately protect the transmission line, set the transmission line distance relays to a maximum of 125% of the apparent impedance (at the impedance angle of the transmission line) subject to the following constraints:
- R1.12.1.** Set the maximum torque angle (MTA) to 90 degrees or the highest supported by the manufacturer.
- R1.12.2.** Evaluate the relay loadability in amperes at the relay trip point at 0.85 per unit voltage and a power factor angle of 30 degrees.
- R1.12.3.** Include a relay setting component of 87% of the current calculated in R1.12.2 in the Facility Rating determination for the circuit.
- R1.13.** Where other situations present practical limitations on circuit capability, set the phase protection relays so they do not operate at or below 115% of such limitations.
- R2.** The Transmission Owner, Generator Owner, or Distribution Provider that uses a circuit capability with the practical limitations described in R1.6, R1.7, R1.8, R1.9, R1.12, or R1.13 shall use the calculated circuit capability as the Facility Rating of the circuit and shall obtain the agreement of the Planning Coordinator, Transmission Operator, and Reliability Coordinator

³ IEEE standard C57.115, Table 3, specifies that transformers are to be designed to withstand a winding hot spot temperature of 180 degrees C, and cautions that bubble formation may occur above 140 degrees C.

with the calculated circuit capability. [Violation Risk Factor: Medium] [Time Horizon: Long Term Planning]

- R3.** The Planning Coordinator shall determine which of the facilities (transmission lines operated at 100 kV to 200 kV and transformers with low voltage terminals connected at 100 kV to 200 kV) in its Planning Coordinator Area are critical to the reliability of the Bulk Electric System to identify the facilities from 100 kV to 200 kV that must meet Requirement 1 to prevent potential cascade tripping that may occur when protective relay settings limit transmission loadability. [Violation Risk Factor: Medium] [Time Horizon: Long Term Planning]

R3.1. The Planning Coordinator shall have a process to determine the facilities that are critical to the reliability of the Bulk Electric System.

R3.1.1. This process shall consider input from adjoining Planning Coordinators and affected Reliability Coordinators.

R3.2. The Planning Coordinator shall maintain a current list of facilities determined according to the process described in R3.1.

R3.3. The Planning Coordinator shall provide a list of facilities to its Reliability Coordinators, Transmission Owners, Generator Owners, and Distribution Providers within 30 days of the establishment of the initial list and within 30 days of any changes to the list.

C. Measures

M1. The Transmission Owner, Generator Owner, and Distribution Provider shall each have evidence to show that each of its transmission relays are set according to one of the criteria in R1.1 through R1.13. (R1)

M2. The Transmission Owner, Generator Owner, and Distribution Provider with transmission relays set according to the criteria in R1.6, R1.7, R1.8, R1.9, R1.12, or R.13 shall have evidence that the resulting Facility Rating was agreed to by its associated Planning Coordinator, Transmission Operator, and Reliability Coordinator. (R2)

M3. The Planning Coordinator shall have a documented process for the determination of facilities as described in R3. The Planning Coordinator shall have a current list of such facilities and shall have evidence that it provided the list to the appropriate Reliability Coordinators, Transmission Operators, Generator Operators, and Distribution Providers. (R3)

D. Compliance

1. Compliance Monitoring Process

1.1. Compliance Monitoring Responsibility

1.1.1 Compliance Enforcement Authority

1.2. Compliance Monitoring Period and Reset Time Frame

One calendar year.

1.3. Data Retention

The Transmission Owner, Generator Owner, and Distribution Provider shall each retain documentation for three years.

The Planning Coordinator shall retain documentation of the most recent review process required in R3. The Planning Coordinator shall retain the most recent list of facilities that are critical to the reliability of the electric system determined per R3.

The Compliance Monitor shall retain its compliance documentation for three years.

1.4. Additional Compliance Information

The Transmission Owner, Generator Owner, Planning Coordinator, and Distribution Provider shall each demonstrate compliance through annual self-certification, or compliance audit (periodic, as part of targeted monitoring or initiated by complaint or event), as determined by the Compliance Enforcement Authority.

2. Violation Severity Levels:

Requirement	Lower	Moderate	High	Severe
R1		Evidence that relay settings comply with criteria in R1.1 through R1.13 exists, but evidence is incomplete or incorrect for one or more of the subrequirements.		Relay settings do not comply with any of the sub requirements R1.1 through R1.13 OR Evidence does not exist to support that relay settings comply with one of the criteria in subrequirements R1.1 through R1.13.
R2	Criteria described in R1.6, R1.7, R1.8, R1.9, R1.12, or R1.13 was used but evidence does not exist that agreement was obtained in accordance with R2.			
R3		Provided the list of facilities critical to the reliability of the Bulk Electric System to the appropriate Reliability Coordinators, Transmission Owners, Generator Owners, and Distribution Providers between 31 days and 45 days after the list was established or updated.	Provided the list of facilities critical to the reliability of the Bulk Electric System to the appropriate Reliability Coordinators, Transmission Owners, Generator Owners, and Distribution Providers between 46 days and 60 days after list was established or updated.	Does not have a process in place to determine facilities that are critical to the reliability of the Bulk Electric System. OR Does not maintain a current list of facilities critical to the reliability of the Bulk Electric System, OR

				Did not provide the list of facilities critical to the reliability of the Bulk Electric System to the appropriate Reliability Coordinators, Transmission Owners, Generator Owners, and Distribution Providers, or provided the list more than 60 days after the list was established or updated.
--	--	--	--	--

E. Regional Differences

None

F. Supplemental Technical Reference Document

1. The following document is an explanatory supplement to the standard. It provides the technical rationale underlying the requirements in this standard. The reference document contains methodology examples for illustration purposes it does not preclude other technically comparable methodologies

“Determination and Application of Practical Relaying Loadability Ratings,” Version 1.0, January 9, 2007, prepared by the System Protection and Control Task Force of the NERC Planning Committee, available at: <http://www.nerc.com/~filez/reports.html>.

Version History

Version	Date	Action	Change Tracking
1	February 12, 2008	Approved by Board of Trustees	New

Attachment A

1. This standard includes any protective functions which could trip with or without time delay, on load current, including but not limited to:
 - 1.1. Phase distance.
 - 1.2. Out-of-step tripping.
 - 1.3. Switch-on-to-fault.
 - 1.4. Overcurrent relays.
 - 1.5. Communications aided protection schemes including but not limited to:
 - 1.5.1 Permissive overreach transfer trip (POTT).
 - 1.5.2 Permissive under-reach transfer trip (PUTT).
 - 1.5.3 Directional comparison blocking (DCB).
 - 1.5.4 Directional comparison unblocking (DCUB).
2. This standard includes out-of-step blocking schemes which shall be evaluated to ensure that they do not block trip for faults during the loading conditions defined within the requirements.
3. The following protection systems are excluded from requirements of this standard:
 - 3.1. Relay elements that are only enabled when other relays or associated systems fail. For example:
 - Overcurrent elements that are only enabled during loss of potential conditions.
 - Elements that are only enabled during a loss of communications.
 - 3.2. Protection systems intended for the detection of ground fault conditions.
 - 3.3. Protection systems intended for protection during stable power swings.
 - 3.4. Generator protection relays that are susceptible to load.
 - 3.5. Relay elements used only for Special Protection Systems applied and approved in accordance with NERC Reliability Standards PRC-012 through PRC-017.
 - 3.6. Protection systems that are designed only to respond in time periods which allow operators 15 minutes or greater to respond to overload conditions.
 - 3.7. Thermal emulation relays which are used in conjunction with dynamic Facility Ratings.
 - 3.8. Relay elements associated with DC lines.
 - 3.9. Relay elements associated with DC converter transformers.

Exhibit B

Standard Drafting Team Roster

Relay Loadability Drafting Team

Chairman	Charles W. Rogers Principal Engineer	Consumers Energy System Planning and Protection 1945 W. Parnall Road Jackson, Michigan 49201	(517) 788-0027 (517) 788-0917 Fx cwrogers@ cmsenergy.com
NERC Consultant	Thomas Wiedman President	Wiedman Power System Consulting Ltd. 4101 S. Pleasant Hill Road Elizabeth, Illinois 61028	(815) 858-2608 (815) 858-2608 Fx twieds@aol.com
	David Angell T&D Planning Engineering Leader	Idaho Power Company P.O. Box 70 Boise, Idaho 83707	(208) 388-2701 (208) 388-6906 Fx DaveAngell@ idahopower.com
	Joseph Burdis Senior Consultant/Engineer, Transmission and Interconnection Planning	PJM Interconnection, L.L.C. 955 Jefferson Avenue Valley Forge Corporate Center Norristown, Pennsylvania 19403-2497	(610) 666-4297 (610) 666-2296 Fx burdis@pjm.com
	W. Mark Carpenter	2509 Douglas Avenue Irving, Texas 75062	(817) 215-6868 mark.carpenter@ oncor.com
	Jim Ingleson Consulting Engineer	New York Independent System Operator 3890 Carman Road Schenectady, New York 12303	(518) 356-6191 (518) 356-6191 Fx jingleson@ nyiso.com
	Richard Maxwell	76 South Main Street Akron, Ohio 44301	(330) 384-7989 maxwellr@ firstenergycorp.com
	Henry G Miller Staff Electrical Engineer	AEP Service Corp. 700 Morrison Rd. 3rd Floor Gahanna, Ohio 43230	(614) 5521125 (614) 552-1645 Fx hgmillr@aep.com
SC Liason	Ronald G. Parsons Manager, Transmission Interconnections and Operations	Alabama Power Company 600 North 18th Street Department ACC Birmingham, Alabama 35291	(205) 257-3333 rgparson@ southernco.com
	Philip Tatro, P.E. Consulting Engineer Transmission Planning	National Grid USA 25 Research Drive Westborough, Massachusetts 01582-0010	(508) 389-2948 (508) 389-4405 Fx philip.tatro@ us.ngrid.com
	Philip B. Winston Manager, Protection and Control	Georgia Power Company 62 Lake Mirror Road Bin# 50061 Forest Park, Georgia 30297-1613	(404) 608-5989 (404) 608-5199 Fx pbwinsto@ southernco.com
	Richard Young Manger, System Protection and Control	American Transmission Company, LLC N19 W23993 Ridgeview Parkway West P.O. Box 47 Waukesha, Wisconsin 53187	(262) 506-6825 (262) 506-6711 Fx ryoung@ atllc.com

NERC Staff Liason	Robert Cummings Director of Event Analysis & Information Exchange	North American Electric Reliability Corporation 116-390 Village Boulevard Princeton, New Jersey 08540-5721	(609) 452-8060 (609) 452-9550 Fx bob.cummings@ nerc.net
NERC Staff	Maureen E. Long Standards Process Manager	North American Electric Reliability Corporation 116-390 Village Boulevard Princeton, New Jersey 08540-5721	(609) 452-8060 (609) 452-9550 Fx melong@ieee.org
NERC Staff	Edward H. Ruck Regional Compliance Program Coordinator	North American Electric Reliability Corporation 116-390 Village Boulevard Princeton, New Jersey 08540-5721	(609) 452-8060 (609) 452-9550 Fx ed.ruck@nerc.net
NERC Staff Facilitator	Harry Tom Standards Development Coordinator	North American Electric Reliability Corporation 116-390 Village Boulevard Princeton, New Jersey 08540-5721	(609) 452-8060 (609) 452-9550 Fx harry.tom@ nerc.net

Exhibit C

The complete development record of the proposed Reliability Standards

[Available upon Request]

Exhibit D
**“PRC-023 Reference – Determination and Application of Practical Relaying
Loadability Ratings”**

PRC-023 Reference

Determination and Application of Practical Relaying Loadability Ratings



North American Electric Reliability Council

Prepared by the
System Protection and Control Task Force
of the
NERC Planning Committee

Version 1.0

August 14, 2006

Table of Contents

INTRODUCTION 1

REQUIREMENTS REFERENCE MATERIAL 2

R1 — PHASE RELAY SETTING 2

R1.1 — TRANSMISSION LINE THERMAL RATING 2

R1.2 — TRANSMISSION LINE ESTABLISHED 15-MINUTE RATING 2

R1.3 — MAXIMUM POWER TRANSFER LIMIT ACROSS A TRANSMISSION LINE..... 3

R1.3.1 — MAXIMUM POWER TRANSFER WITH INFINITE SOURCE..... 3

R1.3.2 — MAXIMUM POWER TRANSFER WITH SYSTEM SOURCE IMPEDANCE..... 5

R1.4 — SPECIAL CONSIDERATIONS FOR SERIES-COMPENSATED LINES 6

R1.5 — WEAK SOURCE SYSTEMS 8

R1.6 — GENERATION REMOTE TO LOAD 9

R1.7 — LOAD REMOTE TO GENERATION 11

R1.8 — REMOTE COHESIVE LOAD CENTER 12

R1.9 — COHESIVE LOAD CENTER REMOTE TO TRANSMISSION SYSTEM..... 13

R1.10 — TRANSFORMER OVERCURRENT PROTECTION 13

R1.11 — TRANSFORMER OVERLOAD PROTECTION 14

R1.12 A — LONG LINE RELAY LOADABILITY – TWO TERMINAL LINES 14

R1.12 B — LONG LINE RELAY LOADABILITY - THREE (OR MORE) TERMINAL LINES AND LINES WITH ONE OR MORE
RADIAL TAPS 16

APPENDICES..... I

APPENDIX A — LONG LINE MAXIMUM POWER TRANSFER EQUATIONS II

APPENDIX B — IMPEDANCE-BASED PILOT RELAYING CONSIDERATIONS IV

APPENDIX C — RELATED READING AND REFERENCES VII

Introduction

This document is intended to provide additional information and guidance for complying with the requirements of Reliability Standard PRC-023.

The function of transmission protection systems included in the referenced reliability standard is to protect the transmission system when subjected to faults. System conditions, particularly during emergency operations, may make it necessary for transmission lines and transformers to become overloaded for short periods of time. During such instances, it is important that protective relays do not *prematurely* trip the transmission elements out-of-service preventing the system operators from taking controlled actions to alleviate the overload. Therefore, protection systems should not interfere with the system operators' ability to consciously take remedial action to protect system reliability. The relay loadability reliability standard has been specifically developed to not interfere with system operator actions, while allowing for short-term overloads, with sufficient margin to allow for inaccuracies in the relays and instrument transformers.

While protection systems are required to comply with the relay loadability requirements of Reliability Standard PRC-023; it is imperative that the protective relays be set to reliably detect all fault conditions and protect the electrical network from these faults.

The following protection functions are addressed by Reliability Standard PRC-023:

1. Any protective functions which could trip with or without time delay, on normal or emergency load current, including but not limited to:
 - 1.1. Phase distance
 - 1.2. Out-of-step tripping
 - 1.3. Out-of-step blocking
 - 1.4. Switch-on-to-fault
 - 1.5. Overcurrent relays
 - 1.6. Communications aided protection schemes including but not limited to:
 - 1.6.1. Permissive overreaching transfer trip (POTT)
 - 1.6.2. Permissive underreaching transfer trip (PUTT)
 - 1.6.3. Directional comparison blocking (DCB)
 - 1.6.4. Directional comparison unblocking (DCUB)
2. The following protection systems are excluded from requirements of this standard:
 - 2.1. Relay elements that are only enabled when other relays or associated systems fail.
 - 2.1.1. Overcurrent elements that are only enabled during loss of potential conditions.
 - 2.1.2. Elements that are only enabled during a loss of communications.
 - 2.2. Protection systems intended for the detection of ground fault conditions.
 - 2.3. Generator protection relays
 - 2.4. Relay elements used only for Special Protection Systems, applied and approved in accordance with NERC Reliability Standards PRC-012 through PRC-017.

Requirements Reference Material

R1 — Phase Relay Setting

Transmission Owners, Generator Owners, and Distribution Providers shall use any one of the following criteria to prevent its phase protective relay settings from limiting transmission system capability while maintaining reliable protection of the electrical network for all fault conditions. The relay performance shall be evaluated at 0.85 per unit voltage and a power factor angle of 30 degrees: [Risk Factor: High]

R1.1 — Transmission Line Thermal Rating

Set transmission line relays so they do not operate at or below 150% of the highest seasonal Facility Rating of a circuit, for the available defined loading duration nearest 4 hours (expressed in amperes).

$$Z_{relay30} = \frac{0.85 \times V_{L-L}}{\sqrt{3} \times 1.5 \times I_{rating}}$$

Where:

$Z_{relay30}$ = Relay reach in primary Ohms at a 30 degree power factor angle

V_{L-L} = Rated line-to-line voltage

I_{rating} = Facility Rating

Set the tripping relay so it does not operate at or below 1.5 times the highest Facility Rating (I_{rating}) of the line for the available defined loading duration nearest 4 hours. When evaluating a distance relay, assume a 0.85 per unit relay voltage and a line phase (power factor) angle of 30 degrees.

Example: $Z_{relay30} = \frac{0.85 \times V_{L-L}}{\sqrt{3} \times 1.5 \times I_{rating}}$

R1.2 — Transmission Line Established 15-Minute Rating

When the original loadability parameters were established, it was based on the 4-hour facility rating. The intent of the 150% factor applied to the facility ampere rating in the loadability requirement was to approximate the 15-minute rating of the transmission line and add some additional margin. Although the original study performed to establish the 150% factor did not segregate the portion of the 150% factor that was to approximate the 15-minute capability from that portion that was to be a safety margin, it has been determined that a 115% margin is appropriate. In situations where detailed studies have been performed to establish 15-minute ratings on a transmission line, the 15-minute rating can be used to establish the loadability requirement for the protective relays.

Set the tripping relay so it does not operate at or below 1.15 times the 15-minute winter facility ampere rating (I_{rating}) of the line. When evaluating a distance relay, assume a 0.85 per unit relay voltage and a line phase (power factor) angle of 30 degrees.

Example:
$$Z_{relay30} = \frac{0.85 \times V_{L-L}}{\sqrt{3} \times 1.15 \times I_{rating}}$$

R1.3 — Maximum Power Transfer Limit Across a Transmission Line

Set transmission line relays so they do not operate at or below 115% of the maximum power transfer capability of the circuit (expressed in amperes) using one of the following to perform the power transfer calculation:

R1.3.1 — Maximum Power Transfer with Infinite Source

An infinite source (zero source impedance) with a 1.00 per unit bus voltage at each end of the line

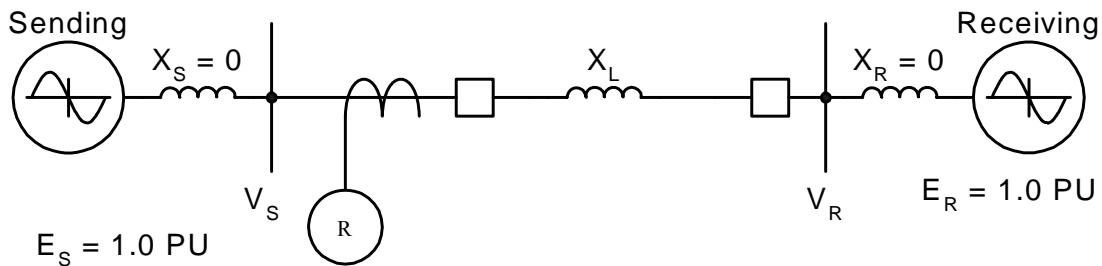

Figure 1 – Maximum Power Transfer

The power transfer across a transmission line (*Figure 1*) is defined by the equation¹:

$$P = \frac{V_S \times V_R \times \sin \delta}{X_L}$$

Where:

- P = the power flow across the transmission line
- V_S = Phase-to-phase voltage at the sending bus
- V_R = Phase-to-phase voltage at the receiving bus
- δ = Voltage angle between V_S and V_R
- X_L = Reactance of the transmission line in ohms

¹ More explicit equations that may be beneficial for long transmission lines (typically 80 miles or more) are contained in Appendix A.

The theoretical maximum power transfer occurs when δ is 90 degrees. The real maximum power transfer will be less than the theoretical maximum power transfer and will occur at some angle less than 90 degrees since the source impedance of the system is not zero. A number of conservative assumptions are made:

- δ is 90 degrees
- Voltage at each bus is 1.0 per unit
- An infinite source is assumed behind each bus; i.e. no source impedance is assumed.

The equation for maximum power becomes:

$$P_{max} = \frac{V^2}{X_L}$$

$$I_{real} = \frac{P_{max}}{\sqrt{3} \times V}$$

$$I_{real} = \frac{V}{\sqrt{3} \times X_L}$$

Where:

P_{max} = Maximum power that can be transferred across a system

I_{real} = Real component of current

V = Nominal phase-to-phase bus voltage

At maximum power transfer, the real component of current and the reactive component of current are equal; therefore:

$$I_{total} = \sqrt{2} \times I_{real}$$

$$I_{total} = \frac{\sqrt{2} \times V}{\sqrt{3} \times X_L}$$

$$I_{total} = \frac{0.816 \times V}{X_L}$$

Where:

I_{total} is the total current at maximum power transfer.

Set the tripping relay so it does not operate at or below 1.15 times I_{total} (where $I_{total} = \frac{0.816 \times V}{X_L}$). When evaluating a distance relay, assume a 0.85 per unit relay voltage and a line phase (power factor) angle of 30 degrees.

Example: $Z_{relay30} = \frac{0.85 \times V_{L-L}}{\sqrt{3} \times 1.15 \times I_{total}}$

R1.3.2 — Maximum Power Transfer with System Source Impedance

Actual source and receiving end impedances are determined using a short circuit program and choosing the classical or flat start option to calculate the fault parameters. The impedances required for this calculation are the generator subtransient impedances (*Figure 2*).

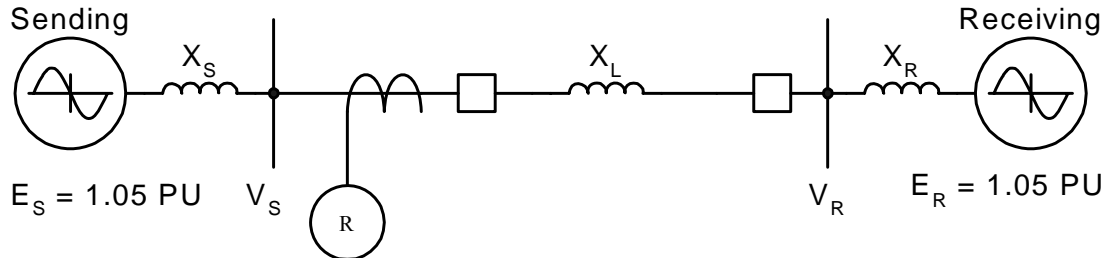

Figure 2 – Site-Specific Maximum Power Transfer Limit

The recommended procedure for determining X_S and X_R is:

- Remove the line or lines under study (parallel lines need to be removed prior to doing the fault study)
- Apply a three-phase short circuit to the sending and receiving end buses.
- The program will calculate a number of fault parameters including the equivalent Thévenin source impedances.
- The real component of the Thévenin impedance is ignored.

The voltage angle across the system is fixed at 90 degrees, and the current magnitude (I_{real}) for the maximum power transfer across the system is determined as follows²:

$$P_{max} = \frac{(1.05 \times V)^2}{(X_S + X_R + X_L)}$$

Where:

- P_{max} = Maximum power that can be transferred across a system
- E_S = Thévenin phase-to-phase voltage at the system sending bus
- E_R = Thévenin phase-to-phase voltage at the system receiving bus
- δ = Voltage angle between E_S and E_R
- X_S = Thévenin equivalent reactance in ohms of the sending bus
- X_R = Thévenin equivalent reactance in ohms of the receiving bus
- X_L = Reactance of the transmission line in ohms
- V = Nominal phase-to-phase system voltage

² More explicit equations that may be beneficial for long transmission lines (typically 80 miles or more) are contained in Appendix A.

$$I_{real} = \frac{1.05 \times V}{\sqrt{3}(X_S + X_R + X_L)}$$

$$I_{real} = \frac{0.606 \times V}{(X_S + X_R + X_L)}$$

The theoretical maximum power transfer occurs when δ is 90 degrees. All stable maximum power transfers will be less than the theoretical maximum power transfer and will occur at some angle less than 90 degrees since the source impedance of the system is not zero. A number of conservative assumptions are made:

- δ is 90 degrees
- Voltage at each bus is 1.05 per unit
- The source impedances are calculated using the sub-transient generator reactances.

At maximum power transfer, the real component of current and the reactive component of current are equal; therefore:

$$I_{total} = \sqrt{2} \times I_{real}$$

$$I_{total} = \frac{\sqrt{2} \times 0.606 \times V}{(X_S + X_R + X_L)}$$

$$I_{total} = \frac{0.857 \times V}{(X_S + X_R + X_L)}$$

Where:

I_{total} = Total current at maximum power transfer

Set the tripping relay so it does not operate at or below 1.15 times I_{total} . When evaluating a distance relay, assume a 0.85 per unit relay voltage and a line phase (power factor) angle of 30 degrees.

Example: $Z_{relay30} = \frac{0.85 \times V_{L-L}}{\sqrt{3} \times 1.15 \times I_{total}}$

This should be re-verified whenever major system changes are made.

R1.4 — Special Considerations for Series-Compensated Lines

Series capacitors are used on long transmission lines to allow increased power transfer. Special consideration must be made in computing the maximum power flow that protective relays must accommodate on series compensated transmission lines. Capacitor cans have a short-term over voltage capability that is defined in IEEE standard 1036. This allows series capacitors to carry currents in excess of their nominal rating for a short term. Series capacitor emergency ratings, typically 30-minute, are frequently specified during design.

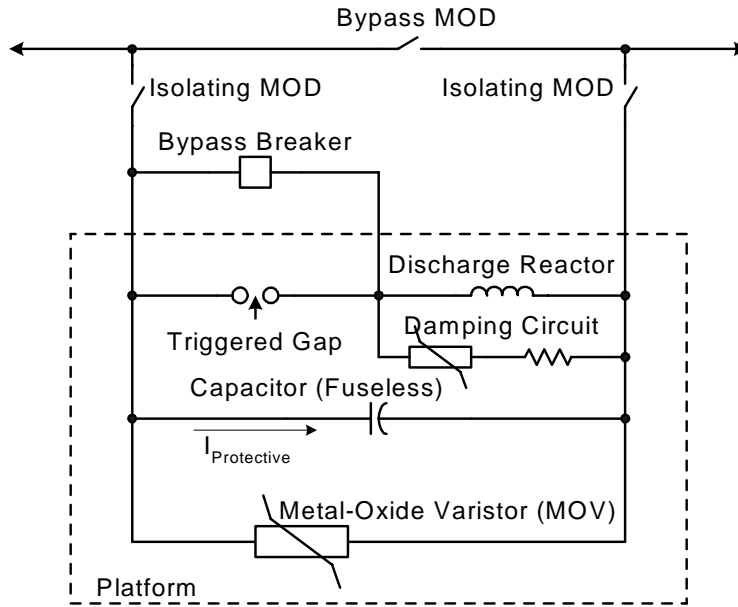

Figure 3 – Series Capacitor Components

The capacitor banks are protected from overload conditions by spark gaps and/or metal oxide varistors (MOVs) and can be also be protected or bypassed by breakers. Protective gaps and MOVs (*Figure 3*) operate on the voltage across the capacitor ($V_{protective}$).

This voltage can be converted to a current by the equation:

$$I_{protective} = \frac{V_{protective}}{X_C}$$

Where:

- $V_{protective}$ = Protective level of voltage across the capacitor spark gaps and/or MOVs
- X_C = Capacitive reactance

The capacitor protection limits the theoretical maximum power flow because I_{total} , assuming the line inductive reactance is reduced by the capacitive reactance, will typically exceed $I_{protective}$. A current of $I_{protective}$ or greater will result in a capacitor bypass. This reduces the theoretical maximum power transfer to that of only the line inductive reactance as described in R1.3.

The relay settings must be evaluated against 115% of the highest series capacitor emergency current rating and the maximum power transfer calculated in R1.3 using the full line inductive reactance (uncompensated line reactance). This must be done to accommodate situations where the capacitor is bypassed for reasons other than $I_{protective}$. The relay must be set to accommodate the greater of these two currents.

Set the tripping relay so it does not operate at or below the greater of:

1. 1.15 times the highest emergency rating of the series capacitor. When evaluating a distance relay, assume a 0.85 per unit relay voltage and a line phase (power factor) angle of 30 degrees.
2. I_{total} (where I_{total} is calculated under R1.3 using the full line inductive reactance). When evaluating a distance relay, assume a 0.85 per unit relay voltage and a line phase (power factor) angle of 30 degrees.

Example:
$$Z_{relay30} = \frac{0.85 \times V_{L-L}}{\sqrt{3} \times 1.15 \times I_{total}}$$

R1.5 — Weak Source Systems

In some cases, the maximum line end three-phase fault current is small relative to the thermal loadability of the conductor. Such cases exist due to some combination of weak sources, long lines, and the topology of the transmission system (*Figure 4*).

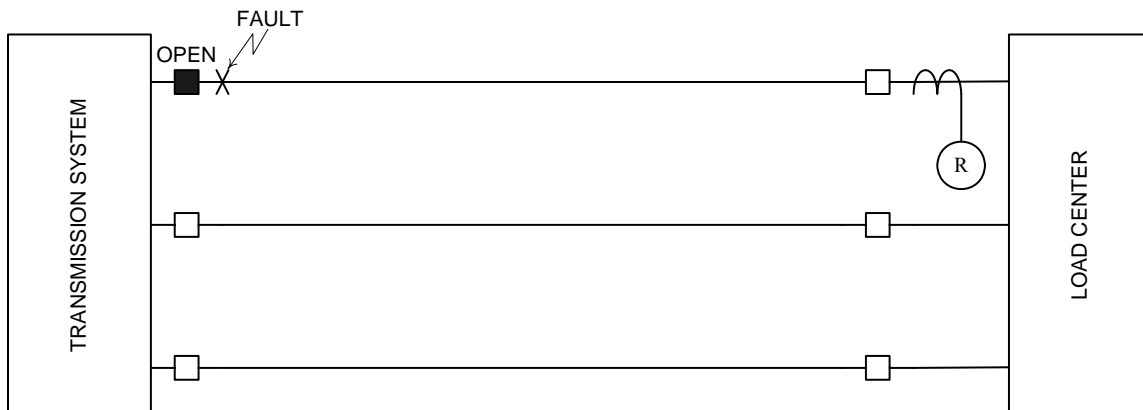

Figure 4 – Weak Source Systems

Since the line end fault is the maximum current at one per unit phase to ground voltage and it is possible to have a voltage of 90 degrees across the line for maximum power transfer across the line, the voltage across the line is equal to:

$$V_{S-R} = \sqrt{V_S^2 + V_R^2} = \sqrt{2} \times V_{LN}$$

It is necessary to increase the line end fault current I_{fault} by $\sqrt{2}$ to reflect the maximum current that the terminal could see for maximum power transfer and by 115% to provide margin for device errors.

$$I_{max} = 1.15 \times \sqrt{2} \times 1.05 \times I_{fault}$$

$$I_{max} = 1.70 \times I_{fault}$$

Where:

I_{fault} is the line-end three-phase fault current magnitude obtained from a short circuit study, reflecting sub-transient generator reactances.

Set the tripping relay on weak-source systems so it does not operate at or below 1.70 times I_{fault} , where I_{fault} is the maximum end of line three-phase fault current magnitude. When evaluating a distance relay, assume a 0.85 per unit relay voltage and a line phase (power factor) angle of 30 degrees.

Example:
$$Z_{relay30} = \frac{0.85 \times V_{L-L}}{\sqrt{3} \times 1.70 \times I_{fault}}$$

R1.6 — Generation Remote to Load

Some system configurations have generation remote to load centers or the main transmission busses. Under these conditions, the total generation in the remote area may limit the total available current from the area towards the load center. In the simple case of generation connected by a single line to the system (Figure 5), the total capability of the generator determines the maximum current (I_{max}) that the line will experience.

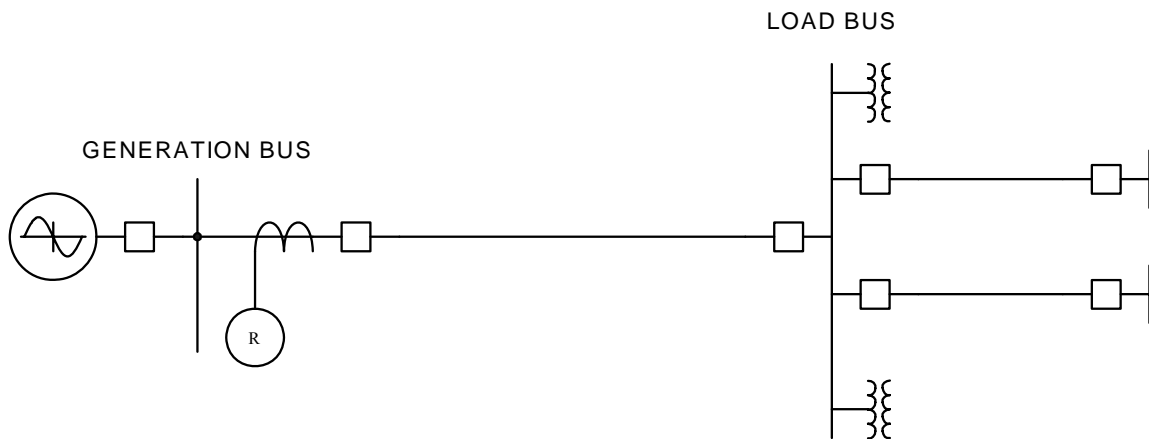

Figure 5 – Generation Remote to Load Center

The total generation output is defined as two times³ the aggregate of the nameplate ratings of the generators in MVA converted to amps at the relay location at 100% voltage:

$$MVA_{max} = 2 \times \sum_1^N \frac{MW_{nameplate}}{PF_{nameplate}}$$

³ This has a basis in the PSRC paper titled: "Performance of Generator Protection During Major System Disturbances", IEEE Paper No. TPWRD-00370-2003, Working Group J6 of the Rotating Machinery Protection Subcommittee, Power System Relaying Committee, 2003. Specifically, page 8 of this paper states: "...distance relays [used for system backup phase fault protection] should be set to carry more than 200% of the MVA rating of the generator at its rated power factor."

$$I_{max} = \frac{MVA_{max}}{\sqrt{3} \times V_{relay}}$$

Where:

V_{relay} = Phase-to-phase voltage at the relay location

N = Number of generators connected to the generation bus

Set the tripping relay so it does not operate at or below 1.15 times the I_{max} . When evaluating a distance relay, assume a 0.85 per unit relay voltage and a line phase (power factor) angle of 30 degrees.

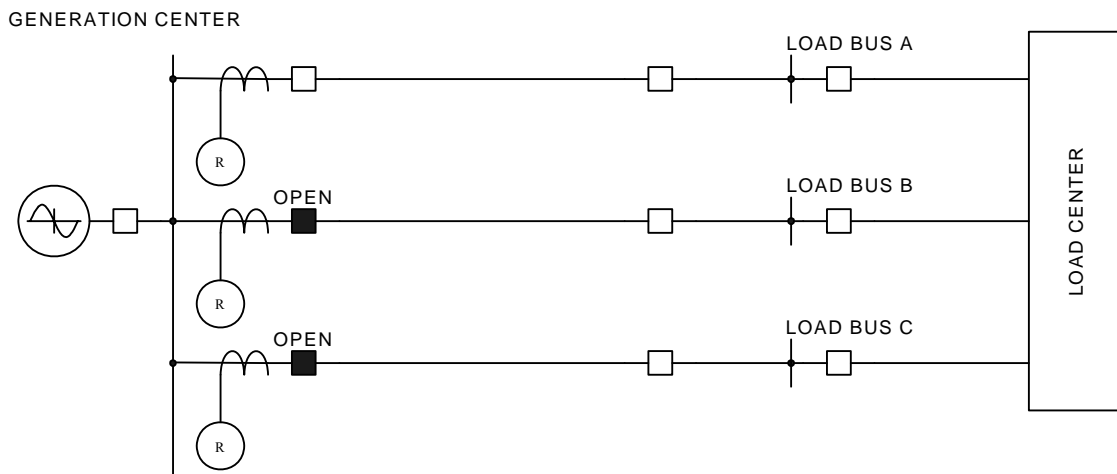

Figure 6 – Generation Connected to System – Multiple Lines

Example: $Z_{relay30} = \frac{0.85 \times V_{L-L}}{\sqrt{3} \times 1.15 \times I_{max}}$

The same general principle can be used if the generator is connected to the system through more than one line (Figure 6). The I_{max} expressed above also applies in this case. To qualify, all transmission lines except the one being evaluated must be open such that the entire generation output is carried across the single transmission line. One must also ensure that loop flow through the system cannot occur such that the total current in the line exceeds I_{max} .

Set the tripping relay so it does not operate at or below 1.15 times I_{max} , if all the other lines that connect the generator to the system are out of service. When evaluating a distance relay, assume a 0.85 per unit relay voltage and a line phase (power factor) angle of 30 degrees.

Example: $Z_{relay30} = \frac{0.85 \times V_{L-L}}{\sqrt{3} \times 1.15 \times I_{max}}$

R1.7 — Load Remote to Generation

Some system configurations have load centers (no appreciable generation) remote from the generation center where under no contingency, would appreciable current flow from the load centers to the generation center (*Figure 7*).

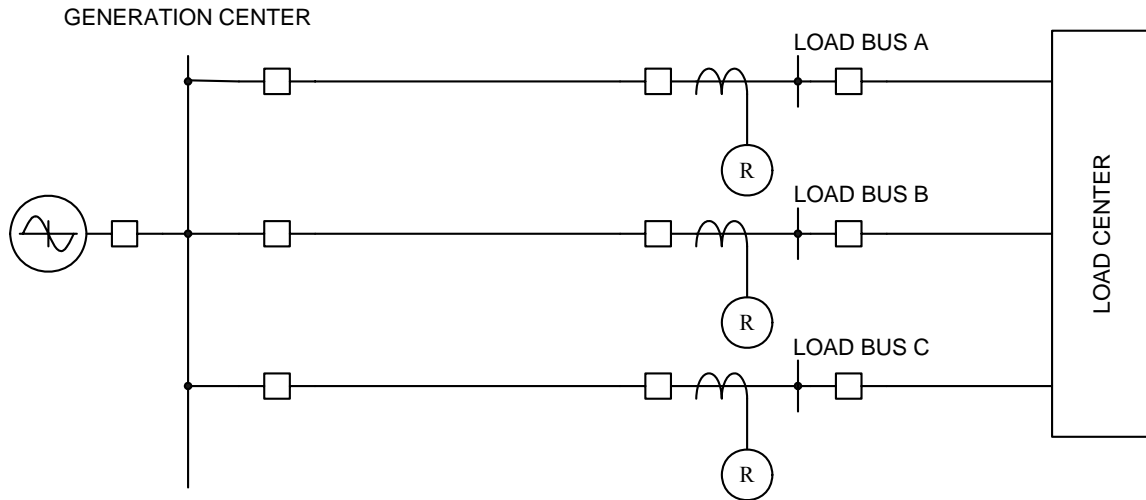

Figure 7 – Load Remote to Generation

Although under normal conditions, only minimal current can flow from the load center to the generation center, the forward reaching relay element on the load center breakers must provide sufficient loadability margin for unusual system conditions. To qualify, one must determine the maximum current flow (I_{max}) from the load center to the generation center under any system contingency.

Set the tripping relay so it does not operate at or below 1.15 times the maximum current flow. When evaluating a distance relay, assume a 0.85 per unit relay voltage and a line phase (power factor) angle of 30 degrees.

Example:
$$Z_{relay30} = \frac{0.85 \times V_{L-L}}{\sqrt{3} \times 1.15 \times I_{max}}$$

R1.8 — Remote Cohesive Load Center

Some system configurations have one or more transmission lines connecting a cohesive, remote, net importing load center to the rest of the system.

For the system shown in *Figure 8*, the total maximum load at the load center defines the maximum load that a single line must carry.



Figure 8 – Remote Cohesive Load Center

Also, one must determine the maximum power flow on an individual line to the area (I_{max}) under all system contingencies, reflecting any higher currents resulting from reduced voltages, and ensure that under no condition will loop current in excess of $I_{maxload}$ flow in the transmission lines.

Set the tripping relay so it does not operate at or below 1.15 times the maximum current flow. When evaluating a distance relay, assume a 0.85 per unit relay voltage and a line phase (power factor) angle of 30 degrees.

Example:
$$Z_{relay30} = \frac{0.85 \times V_{L-L}}{\sqrt{3} \times 1.15 \times I_{max}}$$

R1.9 — Cohesive Load Center Remote to Transmission System

Some system configurations have one or more transmission lines connecting a cohesive, remote, net importing load center to the rest of the system. For the system shown in *Figure 9*, the total maximum load at the load center defines the maximum load that a single line must carry. This applies to the relays at the load center ends of lines addressed in R1.8.



Figure 9 – Cohesive Load Center Remote to Transmission System

Although under normal conditions, only minimal current can flow from the load center to the electrical network, the forward reaching relay element on the load center breakers must provide sufficient loadability margin for unusual system conditions, including all potential loop flows. To qualify, one must determine the maximum current flow (I_{max}) from the load center to the electrical network under any system contingency.

Set the tripping relay so it does not operate at or below 1.15 times the maximum current flow. When evaluating a distance relay, assume a 0.85 per unit relay voltage and a line phase (power factor) angle of 30 degrees.

Example:
$$Z_{relay30} = \frac{0.85 \times V_{L-L}}{\sqrt{3} \times 1.15 \times I_{max}}$$

R1.10 — Transformer Overcurrent Protection

The transformer fault protective relaying settings are set to protect for fault conditions, not excessive load conditions. These fault protection relays are designed to operate relatively quickly. Loading conditions on the order of magnitude of 150% (50% overload) of the maximum applicable nameplate rating of the transformer can normally⁴ be sustained for several minutes without damage or appreciable loss of life to the transformer.

⁴ See ANSI/IEEE Standard C57.92, Table 3.

R1.11 — Transformer Overload Protection

This may be used for those situations where the consequence of a transformer tripping due to an overload condition is less than the potential loss of life or possible damage to the transformer.

1. Provide the protective relay set point(s) for all load-responsive relays on the transformer.
2. Provide the reason or basis for the reduced load capability (below 150% of transformer nameplate or 115% of the operator-established emergency rating, whichever is higher) .
3. Verify that no current or subsequent planning contingency analyses identify any conditions where the recoverable flow is less than the reduced load capability (150% of transformer nameplate or 115% of the highest operator-established emergency rating, whichever is higher) and greater than the trip point.

If an overcurrent relay is supervised by either a top oil or simulated winding hot spot element less than 100° C and 140° C⁵ respectively, justification for the reduced temperature must be provided.

R1.12 a — Long Line Relay Loadability – Two Terminal Lines

This description applies only to classical two-terminal circuits. For lines with other configurations, see R1.12b , *Three (or more) Terminal Lines and Lines with One or More Radial Taps*. A large number of transmission lines in North America are protected with distance based relays that use a mho characteristic. Although other relay characteristics are now available that offer the same fault protection with more immunity to load encroachment, generally they are not required based on the following:

1. The original loadability concern from the Northeast blackout (and other blackouts) was overly sensitive distance relays (usually Zone 3 relays).
2. Distance relays with mho characteristics that are set at 125% of the line length are clearly not “overly sensitive,” and were not responsible for any of the documented cascading outages, under steady-state conditions.
3. It is unlikely that distance relays with mho characteristics set at 125% of line length will misoperate due to recoverable loading during major events.
4. Even though unintentional relay operation due to load could clearly be mitigated with blinders or other load encroachment techniques, in the vast majority of cases, it may not be necessary.

⁵ IEEE standard C57.115, Table 3, specifies that transformers are to be designed to withstand a winding hot spot temperature of 180 degrees C, and cautions that bubble formation may occur above 140 degrees C.

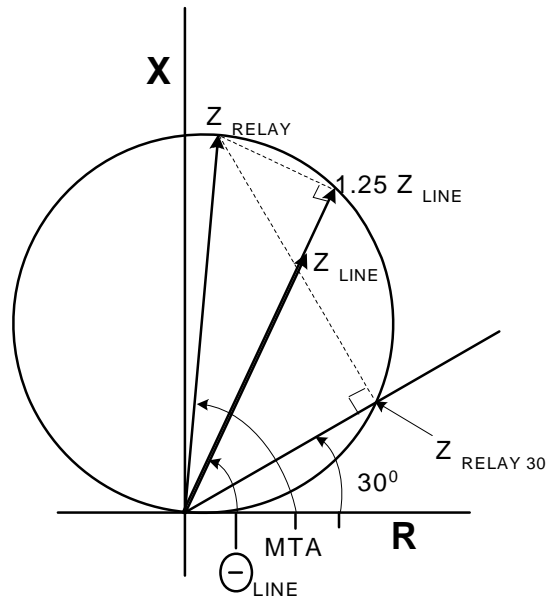

Figure 10 – Long Line relay Loadability

It is prudent that the relays be adjusted to as close to the 90 degree MTA setting as the relay can be set to achieve the highest level of loadability without compromising the ability of the relay to reliably detect faults.

The basis for the current loading is as follows:

- V_{relay} = Phase-to-phase line voltage at the relay location
- Z_{line} = Line impedance
- Θ_{line} = Line impedance angle
- Z_{relay} = Relay setting at the maximum torque angle
- MTA = Maximum torque angle, the angle of maximum relay reach
- $Z_{relay30}$ = Relay trip point at a 30 degree phase angle between the voltage and current
- I_{trip} = Trip current at 30 degrees with normal voltage
- $I_{relay30}$ = Current (including a 15% margin) that the circuit can carry at 0.85 per unit voltage at a 30 degree phase angle between the voltage and current before reaching the relay trip point

For applying a mho relay at any maximum torque angle to any line impedance angle:

$$Z_{relay} = \frac{1.25 \times Z_{line}}{\cos(MTA - \Theta_{line})}$$

The relay reach at the load power factor angle of 30° is determined from:

$$Z_{relay30} = \left[\frac{1.25 \times Z_{line}}{\cos(MTA - \Theta_{line})} \right] \times \cos(MTA - 30^\circ)$$

The relay operating current at the load power factor angle of 30° is:

$$I_{trip} = \frac{V_{relay}}{\sqrt{3} \times Z_{relay30}}$$

$$I_{trip} = \frac{V_{relay} \times \cos(MTA - \Theta_{line})}{\sqrt{3} \times 1.25 \times Z_{line} \times \cos(MTA - 30^\circ)}$$

The load current with a 15% margin factor and the 0.85 per unit voltage requirement is calculated by:

$$I_{relay30} = \frac{0.85 \times I_{trip}}{1.15}$$

$$I_{relay30} = \frac{0.85 \times V_{relay} \times \cos(MTA - \Theta_{line})}{1.15 \times \sqrt{3} \times 1.25 \times Z_{line} \times \cos(MTA - 30^\circ)}$$

$$I_{relay30} = \left(\frac{0.341 \times V_{relay}}{Z_{line}} \right) \times \left(\frac{\cos(MTA - \Theta_{line})}{\cos(MTA - 30^\circ)} \right)$$

R1.12 b — Long Line Relay Loadability — Three (or more) Terminal Lines and Lines with One or More Radial Taps

Three (or more) terminal lines present protective relaying challenges from a loadability standpoint due to the apparent impedance as seen by the different terminals. This includes lines with radial taps. The loadability of the line may be different for each terminal of the line so the loadability must be done on a per terminal basis:

The basis for the current loading is as follows:

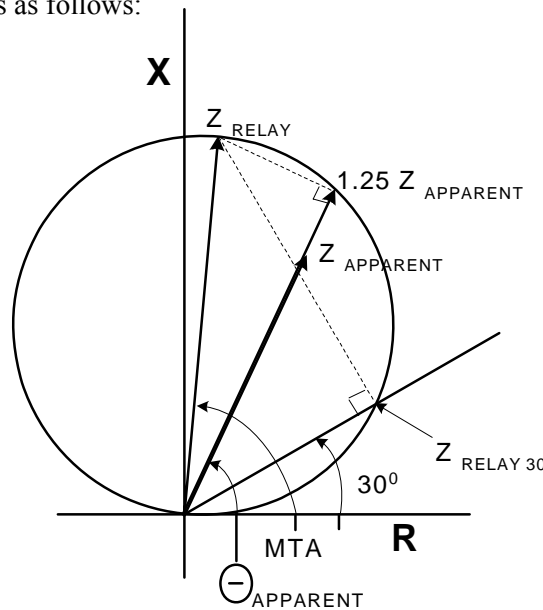

Figure 11 – Three (or more) Terminal Lines and Lines with One or More Radial Taps

V_{relay} = Phase-to-phase line voltage at the relay location

$Z_{apparent}$ = Apparent line impedance as seen from the line terminal. This apparent impedance is the impedance calculated (using in-feed where applicable) for a fault at the most electrically distant line terminal for system conditions normally used in protective relaying setting practices.

$\Theta_{apparent}$ = Apparent line impedance angle as seen from the line terminal

Z_{relay} = Relay setting at the maximum torque angle.

MTA = Maximum torque angle, the angle of maximum relay reach

$Z_{relay30}$ = Relay trip point at a 30 degree phase angle between the voltage and current

I_{trip} = Trip current at 30 degrees with normal voltage

$I_{relay30}$ = Current (including a 15% margin) that the circuit can carry at 0.85 voltage at a 30 degree phase angle between the voltage and current before reaching the trip point

For applying a mho relay at any maximum torque angle to any apparent impedance angle

$$Z_{relay} = \frac{1.25 \times Z_{apparent}}{\cos(MTA - \Theta_{apparent})}$$

The relay reach at the load power factor angle of 30° is determined from:

$$Z_{relay30} = \left[\frac{1.25 \times Z_{apparent}}{\cos(MTA - \Theta_{apparent})} \right] \times \cos(MTA - 30^\circ)$$

The relay operating current at the load power factor angle of 30° is:

$$I_{trip} = \frac{V_{relay}}{\sqrt{3} \times Z_{relay30}}$$

$$I_{trip} = \frac{V_{relay} \times \cos(MTA - \Theta_{apparent})}{\sqrt{3} \times 1.25 \times Z_{apparent} \times \cos(MTA - 30^\circ)}$$

The load current with a 15% margin factor and the 0.85 per unit voltage requirement is calculated by:

$$I_{relay30} = \frac{0.85 \times I_{trip}}{1.15}$$

$$I_{relay30} = \frac{0.85 \times V_{relay} \times \cos(MTA - \Theta_{apparent})}{1.15 \times \sqrt{3} \times 1.25 \times Z_{apparent} \times \cos(MTA - 30^\circ)}$$

$$I_{relay30} = \left(\frac{0.341 \times V_{relay}}{Z_{apparent}} \right) \times \left(\frac{\cos(MTA - \Theta_{apparent})}{\cos(MTA - 30^\circ)} \right)$$

Appendices

Appendix A — Long Line Maximum Power Transfer Equations

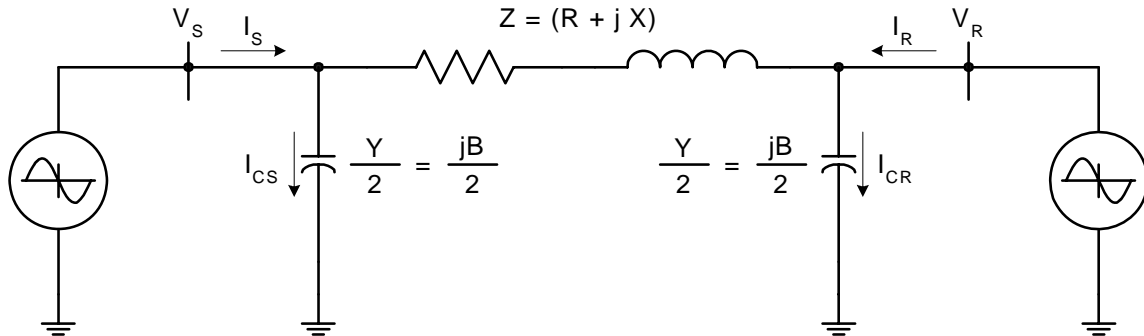

Lengthy transmission lines have significant series resistance, reactance, and shunt capacitance. The line resistance consumes real power when current flows through the line and increases the real power input during maximum power transfer. The shunt capacitance supplies reactive current, which impacts the sending end reactive power requirements of the transmission line during maximum power transfer. These line parameters should be used when calculating the maximum line power flow.

The following equations may be used to compute the maximum power transfer:

$$P_{S3-\phi} = \frac{V_S^2}{|Z|} \cos(\theta^\circ) - \frac{V_S V_R}{|Z|} \cos(\theta + \delta^\circ)$$

$$Q_{S3-\phi} = \frac{V_S^2}{|Z|} \sin(\theta^\circ) - V_S^2 \frac{B}{2} - \frac{V_S V_R}{|Z|} \sin(\theta + \delta^\circ)$$

The equations for computing the total line current are below. These equations assume the condition of maximum power transfer, $\delta = 90^\circ$, and nominal voltage at both the sending and receiving line ends:

$$I_{real} = \frac{V}{\sqrt{3}|Z|} (\cos(\theta^\circ) + \sin(\theta^\circ))$$

$$I_{reactive} = \frac{V}{\sqrt{3}|Z|} \left(\sin(\theta^\circ) - |Z| \frac{B}{2} - \cos(\theta^\circ) \right)$$

$$I_{total} = I_{real} + jI_{reactive}$$

$$I_{total} = \sqrt{I_{real}^2 + I_{reactive}^2}$$

Where:

P = the power flow across the transmission line

V_S = Phase-to-phase voltage at the sending bus

V_R = Phase-to-phase voltage at the receiving bus

V = Nominal phase-to-phase bus voltage

δ = Voltage angle between V_S and V_R

Z = Reactance, including fixed shunt reactors, of the transmission line in ohms*

Θ = Line impedance angle

B = Shunt susceptance of the transmission line in mhos*

- * The use of hyperbolic functions to calculate these impedances is recommended to reflect the distributed nature of long line reactance and capacitance.

Appendix B — Impedance-Based Pilot Relaying Considerations

Some utilities employ communication-aided (pilot) relaying schemes which, taken as a whole, may have a higher loadability than would otherwise be implied by the setting of the forward (overreaching) impedance elements. Impedance based pilot relaying schemes may comply with PRC-023 R1 if all of the following conditions are satisfied

1. The overreaching impedance elements are used only as part of the pilot scheme itself – i.e., not also in conjunction with a Zone 2 timer which would allow them to trip independently of the pilot scheme.
2. The scheme is of the permissive overreaching transfer trip type, requiring relays at all terminals to sense an internal fault as a condition for tripping any terminal.
3. The permissive overreaching transfer trip scheme has not been modified to include weak infeed logic or other logic which could allow a terminal to trip even if the (closed) remote terminal does not sense an internal fault condition with its own forward-reaching elements. Unmodified directional comparison unblocking schemes are equivalent to permissive overreaching transfer trip in this context. Directional comparison blocking schemes will generally not qualify.

For purposes of this discussion, impedance-based pilot relaying schemes fall into two general classes:

1. Unmodified permissive overreaching transfer trip (POTT) (requires relays at all terminals to sense an internal fault as a condition for tripping any terminal). Unmodified directional comparison unblocking schemes are equivalent to permissive overreach in this context.
2. Directional comparison blocking (DCB) (requires relays at one terminal to sense an internal fault, and relays at all other terminals to not sense an external fault as a condition for tripping the terminal). Depending on the details of scheme operation, the criteria for determining that a fault is external may be based on current magnitude and/or on the response of directionally-sensitive relays. Permissive schemes which have been modified to include “echo” or “weak source” logic fall into the DCB class.

Unmodified POTT schemes may offer a significant advantage in loadability as compared with a non-pilot scheme. Modified POTT and DCB schemes will generally offer no such advantage. Both applications are discussed below.

Unmodified Permissive Overreaching Transfer Trip

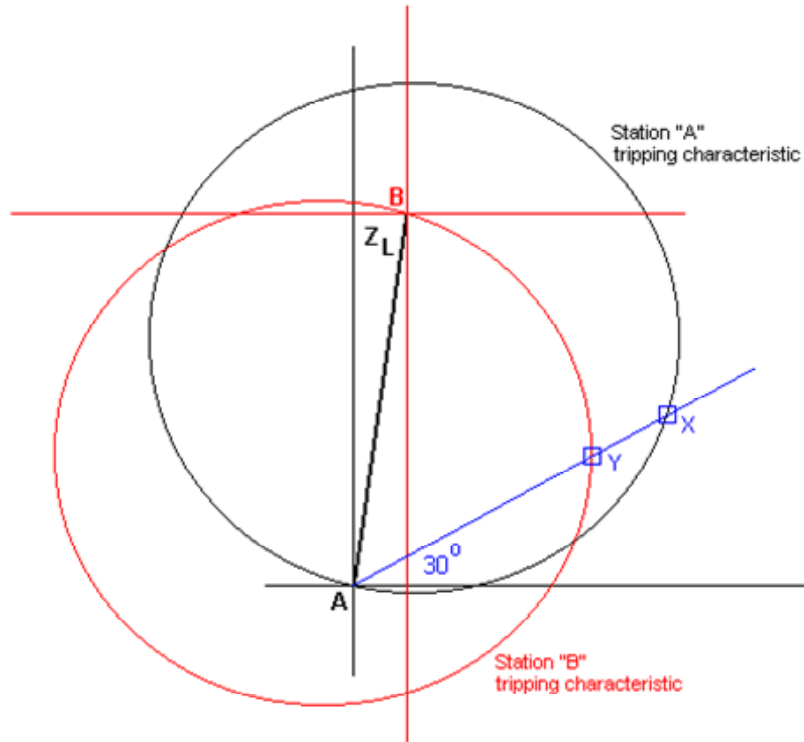

Figure 1 Permissive Overreaching Transferred Trip (unmodified)

In a non-pilot application, the loadability of the tripping relay at Station “A” is determined by the reach of the impedance characteristic at an angle of 30 degrees, or the length of line AX in Figure 1. In a POTT application, point “X” falls outside the tripping characteristic of the relay at Station “B”, preventing tripping at either terminal. Relay “A” becomes susceptible to tripping along its 30-degree line only when point “Y” is reached. Loadability will therefore be increased according to the ratio of AX to AY, which may be sufficient to meet the loadability requirement with no mitigating measures being necessary.

Directional Comparison Blocking

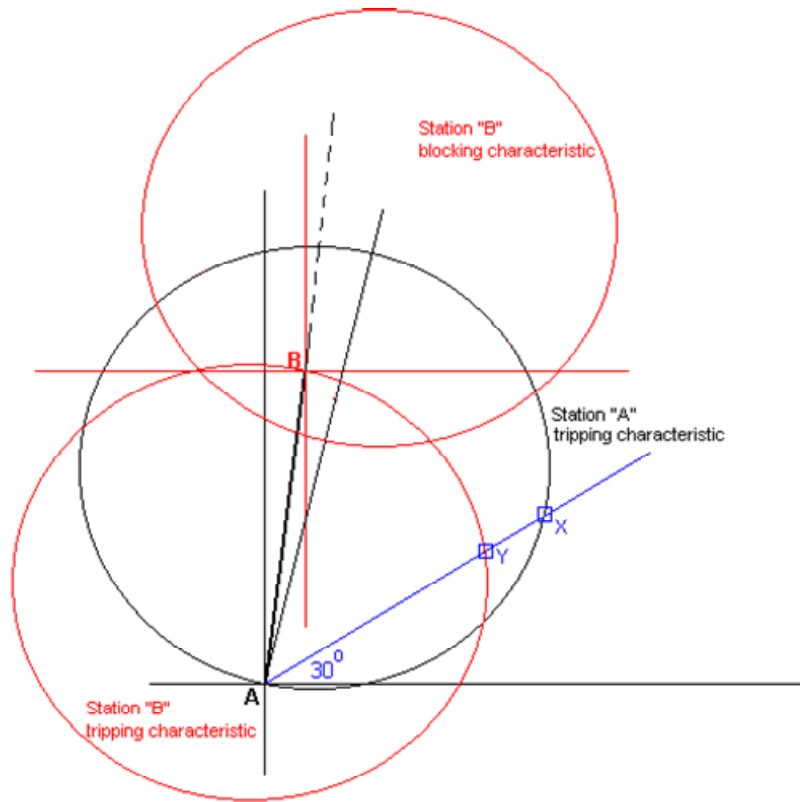

Figure 2 Directional Comparison Blocking with reverse-looking blocking elements

In Figure 2, blocking at Station “B” utilizes impedance elements which may or may not have offset. The settings of the blocking elements are traditionally based on external fault conditions only. It is unlikely that the blocking characteristic at Station “B” will extend into the load region of the tripping characteristic at Station “A”. The loadability of Relay “A” will therefore almost invariably be determined by the impedance AX.

Appendix C — Related Reading and References

The following related IEEE technical papers are available at:

<http://pes-psrc.org>

under the link for "Published Reports"

The listed IEEE Standards are available from the IEEE Standards Association at:

<http://shop.ieee.org/ieeestore>

The listed ANSI Standards are available directly from the American National Standards Institute at

<http://webstore.ansi.org/ansidocstore/default.asp>

-
1. *Performance of Generator Protection During Major System Disturbances*, IEEE Paper No. TPWRD-00370-2003, Working Group J6 of the Rotating Machinery Protection Subcommittee, Power System Relaying Committee, 2003.
 2. *Transmission Line Protective Systems Loadability*, Working Group D6 of the Line Protection Subcommittee, Power System Relaying Committee, March 2001.
 3. *Practical Concepts in Capability and Performance of Transmission Lines*, H. P. St. Clair, IEEE Transactions, December 1953, pp. 1152–1157.
 4. *Analytical Development of Loadability Characteristics for EHV and UHV Transmission Lines*, R. D. Dunlop, R. Gutman, P. P. Marchenko, IEEE transactions on Power Apparatus and Systems, Vol. PAS –98, No. 2 March-April 1979, pp. 606–617.
 5. *EHV and UHV Line Loadability Dependence on var Supply Capability*, T. W. Kay, P. W. Sauer, R. D. Shultz, R. A. Smith, IEEE transactions on Power Apparatus and Systems, Vol. PAS –101, No. 9 September 1982, pp. 3568–3575.
 6. *Application of Line Loadability Concepts to Operating Studies*, R. Gutman, IEEE Transactions on Power Systems, Vol. 3, No. 4 November 1988, pp. 1426–1433.
 7. IEEE Standard C37.113, *IEEE Guide for Protective Relay Applications to Transmission Lines*
 8. ANSI Standard C50.13, *American National Standard for Cylindrical Rotor Synchronous Generators*.
 9. ANSI Standard C84.1, *American National Standard for Electric Power Systems and Equipment – Voltage Ratings (60 Hertz)*, 1995
 10. IEEE Standard 1036, *IEEE Guide for Application of Shunt Capacitors*, 1992.
 11. J. J. Grainger & W. D. Stevenson, Jr., *Power System Analysis*, McGraw- Hill Inc., 1994, Chapter 6 Sections 6.4 – 6.7, pp 202 – 215.
 12. *Final Report on the August 14, 2003 Blackout in the United States and Canada: Causes and Recommendations*, U.S.-Canada Power System Outage Task Force, April 2004.
 13. August 14, 2003 Blackout: NERC Actions to Prevent and Mitigate the Impacts of Future Cascading Blackouts, approved by the NERC Board of Trustees, February 10, 200