

**Exhibit A**

**Proposed Reliability Standard PRC-026-1**

## A. Introduction

1. **Title:** Relay Performance During Stable Power Swings
2. **Number:** PRC-026-1
3. **Purpose:** To ensure that load-responsive protective relays are expected to not trip in response to stable power swings during non-Fault conditions.
4. **Applicability:**
  - 4.1. **Functional Entities:**
    - 4.1.1 Generator Owner that applies load-responsive protective relays as described in PRC-026-1 – Attachment A at the terminals of the Elements listed in Section 4.2, Facilities.
    - 4.1.2 Planning Coordinator.
    - 4.1.3 Transmission Owner that applies load-responsive protective relays as described in PRC-026-1 – Attachment A at the terminals of the Elements listed in Section 4.2, Facilities.
  - 4.2. **Facilities:** The following Elements that are part of the Bulk Electric System (BES):
    - 4.2.1 Generators.
    - 4.2.2 Transformers.
    - 4.2.3 Transmission lines.
5. **Background:**

This is the third phase of a three-phased standard development project that focused on developing this new Reliability Standard to address protective relay operations due to stable power swings. The March 18, 2010, Federal Energy Regulatory Commission (FERC) Order No. 733 approved Reliability Standard PRC-023-1 – Transmission Relay Loadability. In that Order, FERC directed NERC to address three areas of relay loadability that include modifications to the approved PRC-023-1, development of a new Reliability Standard to address generator protective relay loadability, and a new Reliability Standard to address the operation of protective relays due to stable power swings. This project's SAR addresses these directives with a three-phased approach to standard development.

Phase 1 focused on making the specific modifications from FERC Order No. 733 to PRC-023-1. Reliability Standard PRC-023-2, which incorporated these modifications, became mandatory on July 1, 2012.

Phase 2 focused on developing a new Reliability Standard, PRC-025-1 – Generator Relay Loadability, to address generator protective relay loadability. PRC-025-1 became mandatory on October 1, 2014, along with PRC-023-3, which was modified to harmonize PRC-023-2 with PRC-025-1.

Phase 3 focuses on preventing protective relays from tripping unnecessarily due to stable power swings by requiring identification of Elements on which a stable or unstable power swing may affect Protection System operation, assessment of the security of load-

responsive protective relays to tripping in response to only a stable power swing, and implementation of Corrective Action Plans (CAP), where necessary. Phase 3 improves security of load-responsive protective relays for stable power swings so they are expected to not trip in response to stable power swings during non-Fault conditions while maintaining dependable fault detection and dependable out-of-step tripping.

**6. Effective Dates:**

**Requirement R1**

First day of the first full calendar year that is 12 months after the date that the standard is approved by an applicable governmental authority or as otherwise provided for in a jurisdiction where approval by an applicable governmental authority is required for a standard to go into effect. Where approval by an applicable governmental authority is not required, the standard shall become effective on the first day of the first full calendar year that is 12 months after the date the standard is adopted by the NERC Board of Trustees or as otherwise provided for in that jurisdiction.

**Requirements R2, R3, and R4**

First day of the first full calendar year that is 36 months after the date that the standard is approved by an applicable governmental authority or as otherwise provided for in a jurisdiction where approval by an applicable governmental authority is required for a standard to go into effect. Where approval by an applicable governmental authority is not required, the standard shall become effective on the first day of the first full calendar year that is 36 months after the date the standard is adopted by the NERC Board of Trustees or as otherwise provided for in that jurisdiction.

## B. Requirements and Measures

**R1.** Each Planning Coordinator shall, at least once each calendar year, provide notification of each generator, transformer, and transmission line BES Element in its area that meets one or more of the following criteria, if any, to the respective Generator Owner and Transmission Owner: *[Violation Risk Factor: Medium] [Time Horizon: Long-term Planning]*

Criteria:

1. Generator(s) where an angular stability constraint exists that is addressed by a System Operating Limit (SOL) or a Remedial Action Scheme (RAS) and those Elements terminating at the Transmission station associated with the generator(s).
  2. An Element that is monitored as part of an SOL identified by the Planning Coordinator's methodology<sup>1</sup> based on an angular stability constraint.
  3. An Element that forms the boundary of an island in the most recent underfrequency load shedding (UFLS) design assessment based on application of the Planning Coordinator's criteria for identifying islands, only if the island is formed by tripping the Element due to angular instability.
  4. An Element identified in the most recent annual Planning Assessment where relay tripping occurs due to a stable or unstable<sup>2</sup> power swing during a simulated disturbance.
- M1.** Each Planning Coordinator shall have dated evidence that demonstrates notification of the generator, transformer, and transmission line BES Element(s) that meet one or more of the criteria in Requirement R1, if any, to the respective Generator Owner and Transmission Owner. Evidence may include, but is not limited to, the following documentation: emails, facsimiles, records, reports, transmittals, lists, or spreadsheets.

---

<sup>1</sup> NERC Reliability Standard FAC-014-2 – Establish and Communicate System Operating Limits, Requirement R3.

<sup>2</sup> An example of an unstable power swing is provided in the Guidelines and Technical Basis section, "Justification for Including Unstable Power Swings in the Requirements section of the Guidelines and Technical Basis."

- R2.** Each Generator Owner and Transmission Owner shall: [Violation Risk Factor: High] [Time Horizon: Operations Planning]
- 2.1** Within 12 full calendar months of notification of a BES Element pursuant to Requirement R1, determine whether its load-responsive protective relay(s) applied to that BES Element meets the criteria in PRC-026-1 – Attachment B where an evaluation of that Element’s load-responsive protective relay(s) based on PRC-026-1 – Attachment B criteria has not been performed in the last five calendar years.
- 2.2** Within 12 full calendar months of becoming aware<sup>3</sup> of a generator, transformer, or transmission line BES Element that tripped in response to a stable or unstable<sup>4</sup> power swing due to the operation of its protective relay(s), determine whether its load-responsive protective relay(s) applied to that BES Element meets the criteria in PRC-026-1 – Attachment B.
- M2.** Each Generator Owner and Transmission Owner shall have dated evidence that demonstrates the evaluation was performed according to Requirement R2. Evidence may include, but is not limited to, the following documentation: apparent impedance characteristic plots, email, design drawings, facsimiles, R-X plots, software output, records, reports, transmittals, lists, settings sheets, or spreadsheets.
- R3.** Each Generator Owner and Transmission Owner shall, within six full calendar months of determining a load-responsive protective relay does not meet the PRC-026-1 – Attachment B criteria pursuant to Requirement R2, develop a Corrective Action Plan (CAP) to meet one of the following: [*Violation Risk Factor: Medium*] [*Time Horizon: Operations Planning*]
- The Protection System meets the PRC-026-1 – Attachment B criteria, while maintaining dependable fault detection and dependable out-of-step tripping (if out-of-step tripping is applied at the terminal of the BES Element); or
  - The Protection System is excluded under the PRC-026-1 – Attachment A criteria (e.g., modifying the Protection System so that relay functions are supervised by power swing blocking or using relay systems that are immune to power swings), while maintaining dependable fault detection and dependable out-of-step tripping (if out-of-step tripping is applied at the terminal of the BES Element).
- M3.** The Generator Owner and Transmission Owner shall have dated evidence that demonstrates the development of a CAP in accordance with Requirement R3. Evidence may include, but is not limited to, the following documentation: corrective action plans, maintenance records, settings sheets, project or work management program records, or work orders.
- R4.** Each Generator Owner and Transmission Owner shall implement each CAP developed pursuant to Requirement R3 and update each CAP if actions or timetables change until all actions are complete. [*Violation Risk Factor: Medium*][*Time Horizon: Long-Term Planning*]

- M4.** The Generator Owner and Transmission Owner shall have dated evidence that demonstrates implementation of each CAP according to Requirement R4, including updates to the CAP when actions or timetables change. Evidence may include, but is not limited to, the following documentation: corrective action plans, maintenance records, settings sheets, project or work management program records, or work orders.

## **C. Compliance**

### **1. Compliance Monitoring Process**

#### **1.1. Compliance Enforcement Authority**

As defined in the NERC Rules of Procedure, “Compliance Enforcement Authority” (CEA) means NERC or the Regional Entity in their respective roles of monitoring and enforcing compliance with the NERC Reliability Standards.

#### **1.2. Evidence Retention**

The following evidence retention periods identify the period of time an entity is required to retain specific evidence to demonstrate compliance. For instances where the evidence retention period specified below is shorter than the time since the last audit, the CEA may ask an entity to provide other evidence to show that it was compliant for the full time period since the last audit.

The Generator Owner, Planning Coordinator, and Transmission Owner shall keep data or evidence to show compliance as identified below unless directed by its CEA to retain specific evidence for a longer period of time as part of an investigation.

- The Planning Coordinator shall retain evidence of Requirement R1 for a minimum of one calendar year following the completion of the Requirement.
- The Generator Owner and Transmission Owner shall retain evidence of Requirement R2 evaluation for a minimum of 12 calendar months following completion of each evaluation where a CAP is not developed.
- The Generator Owner and Transmission Owner shall retain evidence of Requirements R2, R3, and R4 for a minimum of 12 calendar months following completion of each CAP.

If a Generator Owner, Planning Coordinator, or Transmission Owner is found non-compliant, it shall keep information related to the non-compliance until mitigation is complete and approved, or for the time specified above, whichever is longer.

---

<sup>3</sup> Some examples of the ways an entity may become aware of a power swing are provided in the Guidelines and Technical Basis section, “Becoming Aware of an Element That Tripped in Response to a Power Swing.”

<sup>4</sup> An example of an unstable power swing is provided in the Guidelines and Technical Basis section, “Justification for Including Unstable Power Swings in the Requirements section of the Guidelines and Technical Basis.”

The CEA shall keep the last audit records and all requested and submitted subsequent audit records.

**1.3. Compliance Monitoring and Assessment Processes:**

As defined in the NERC Rules of Procedure; “Compliance Monitoring and Assessment Processes” refers to the identification of the processes that will be used to evaluate data or information for the purpose of assessing performance or outcomes with the associated reliability standard.

**1.4. Additional Compliance Information**

None.

Table of Compliance Elements

R#	Time Horizon	VRF	Violation Severity Levels			
			Lower VSL	Moderate VSL	High VSL	Severe VSL
R1	Long-term Planning	Medium	The Planning Coordinator provided notification of the BES Element(s) in accordance with Requirement R1, but was less than or equal to 30 calendar days late.	The Planning Coordinator provided notification of the BES Element(s) in accordance with Requirement R1, but was more than 30 calendar days and less than or equal to 60 calendar days late.	The Planning Coordinator provided notification of the BES Element(s) in accordance with Requirement R1, but was more than 60 calendar days and less than or equal to 90 calendar days late.	The Planning Coordinator provided notification of the BES Element(s) in accordance with Requirement R1, but was more than 90 calendar days late.  OR  The Planning Coordinator failed to provide notification of the BES Element(s) in accordance with Requirement R1.



R#	Time Horizon	VRF	Violation Severity Levels			
			Lower VSL	Moderate VSL	High VSL	Severe VSL
<b>R2</b>	Operations Planning	High	The Generator Owner or Transmission Owner evaluated its load-responsive protective relay(s) in accordance with Requirement R2, but was less than or equal to 30 calendar days late.	The Generator Owner or Transmission Owner evaluated its load-responsive protective relay(s) in accordance with Requirement R2, but was more than 30 calendar days and less than or equal to 60 calendar days late.	The Generator Owner or Transmission Owner evaluated its load-responsive protective relay(s) in accordance with Requirement R2, but was more than 60 calendar days and less than or equal to 90 calendar days late.	The Generator Owner or Transmission Owner evaluated its load-responsive protective relay(s) in accordance with Requirement R2, but was more than 90 calendar days late.  OR The Generator Owner or Transmission Owner failed to evaluate its load-responsive protective relay(s) in accordance with Requirement R2.

R#	Time Horizon	VRF	Violation Severity Levels			
			Lower VSL	Moderate VSL	High VSL	Severe VSL
<b>R3</b>	Long-term Planning	Medium	The Generator Owner or Transmission Owner developed a Corrective Action Plan (CAP) in accordance with Requirement R3, but in more than six calendar months and less than or equal to seven calendar months.	The Generator Owner or Transmission Owner developed a Corrective Action Plan (CAP) in accordance with Requirement R3, but in more than seven calendar months and less than or equal to eight calendar months.	The Generator Owner or Transmission Owner developed a Corrective Action Plan (CAP) in accordance with Requirement R3, but in more than eight calendar months and less than or equal to nine calendar months.	The Generator Owner or Transmission Owner developed a Corrective Action Plan (CAP) in accordance with Requirement R3, but in more than nine calendar months.  OR The Generator Owner or Transmission Owner failed to develop a CAP in accordance with Requirement R3.
<b>R4</b>	Long-term Planning	Medium	The Generator Owner or Transmission Owner implemented a Corrective Action Plan (CAP), but failed to update a CAP when actions or timetables changed, in accordance with Requirement R4.	N/A	N/A	The Generator Owner or Transmission Owner failed to implement a Corrective Action Plan (CAP) in accordance with Requirement R4.

#### D. Regional Variances

None.

#### E. Interpretations

None.

#### F. Associated Documents

*Applied Protective Relaying*, Westinghouse Electric Corporation, 1979.

Burdy, John, *Loss-of-excitation Protection for Synchronous Generators GER-3183*, General Electric Company.

IEEE Power System Relaying Committee WG D6, *Power Swing and Out-of-Step Considerations on Transmission Lines*, July 2005: <http://www.pes-psrc.org/Reports/Power%20Swing%20and%20OOS%20Considerations%20on%20Transmission%20Lines%20F..pdf>.

Kimbark Edward Wilson, *Power System Stability, Volume II: Power Circuit Breakers and Protective Relays*, Published by John Wiley and Sons, 1950.

Kundur, Prabha, *Power System Stability and Control*, 1994, Palo Alto: EPRI, McGraw Hill, Inc.

NERC System Protection and Control Subcommittee, *Protection System Response to Power Swings*, August 2013: [http://www.nerc.com/comm/PC/System%20Protection%20and%20Control%20Subcommittee%20SPCS%2020/SPCS%20Power%20Swing%20Report\\_Final\\_20131015.pdf](http://www.nerc.com/comm/PC/System%20Protection%20and%20Control%20Subcommittee%20SPCS%2020/SPCS%20Power%20Swing%20Report_Final_20131015.pdf).

Reimert, Donald, *Protective Relaying for Power Generation Systems*, 2006, Boca Raton: CRC Press.

#### Version History

Version	Date	Action	Change Tracking
1.0	TBD	Effective Date	New
2	November 13, 2014	Adopted by NERC Board of Trustees	

**PRC-026-1 – Attachment A**

This standard applies to any protective functions which could trip instantaneously or with a time delay of less than 15 cycles on load current (i.e., “load-responsive”) including, but not limited to:

- Phase distance
- Phase overcurrent
- Out-of-step tripping
- Loss-of-field

The following protection functions are excluded from Requirements of this standard:

- Relay elements supervised by power swing blocking
- Relay elements that are only enabled when other relays or associated systems fail. For example:
  - Overcurrent elements that are only enabled during loss of potential conditions.
  - Relay elements that are only enabled during a loss of communications
- Thermal emulation relays which are used in conjunction with dynamic Facility Ratings
- Relay elements associated with direct current (dc) lines
- Relay elements associated with dc converter transformers
- Phase fault detector relay elements employed to supervise other load-responsive phase distance elements (i.e., in order to prevent false operation in the event of a loss of potential)
- Relay elements associated with switch-onto-fault schemes
- Reverse power relay on the generator
- Generator relay elements that are armed only when the generator is disconnected from the system, (e.g., non-directional overcurrent elements used in conjunction with inadvertent energization schemes, and open breaker flashover schemes)
- Current differential relay, pilot wire relay, and phase comparison relay
- Voltage-restrained or voltage-controlled overcurrent relays

**PRC-026-1 – Attachment B**

Criterion A:

An impedance-based relay used for tripping is expected to not trip for a stable power swing, when the relay characteristic is completely contained within the unstable power swing region.<sup>5</sup> The unstable power swing region is formed by the union of three shapes in the impedance (R-X) plane; (1) a lower loss-of-synchronism circle based on a ratio of the sending-end to receiving-end voltages of 0.7; (2) an upper loss-of-synchronism circle based on a ratio of the sending-end to receiving-end voltages of 1.43; (3) a lens that connects the endpoints of the total system impedance (with the parallel transfer impedance removed) bounded by varying the sending-end and receiving-end voltages from 0.0 to 1.0 per unit, while maintaining a constant system separation angle across the total system impedance where:

1. The system separation angle is:
  - At least 120 degrees, or
  - An angle less than 120 degrees where a documented transient stability analysis demonstrates that the expected maximum stable separation angle is less than 120 degrees.
2. All generation is in service and all transmission BES Elements are in their normal operating state when calculating the system impedance.
3. Saturated (transient or sub-transient) reactance is used for all machines.

---

<sup>5</sup> Guidelines and Technical Basis, Figures 1 and 2.

**PRC-026-1 – Attachment B**

Criterion B:

The pickup of an overcurrent relay element used for tripping, that is above the calculated current value (with the parallel transfer impedance removed) for the conditions below:

1. The system separation angle is:
  - At least 120 degrees, or
  - An angle less than 120 degrees where a documented transient stability analysis demonstrates that the expected maximum stable separation angle is less than 120 degrees.
2. All generation is in service and all transmission BES Elements are in their normal operating state when calculating the system impedance.
3. Saturated (transient or sub-transient) reactance is used for all machines.
4. Both the sending-end and receiving-end voltages at 1.05 per unit.

### Guidelines and Technical Basis

#### Introduction

The NERC System Protection and Control Subcommittee technical document, *Protection System Response to Power Swings*, August 2013,<sup>6</sup> (“PSRPS Report” or “report”) was specifically prepared to support the development of this NERC Reliability Standard. The report provided a historical perspective on power swings as early as 1965 up through the approval of the report by the NERC Planning Committee. The report also addresses reliability issues regarding trade-offs between security and dependability of Protection Systems, considerations for this NERC Reliability Standard, and a collection of technical information about power swing characteristics and varying issues with practical applications and approaches to power swings. Of these topics, the report suggests an approach for this NERC Reliability Standard (“standard” or “PRC-026-1”) which is consistent with addressing three regulatory directives in the FERC Order No. 733. The first directive concerns the need for “...protective relay systems that differentiate between faults and stable power swings and, when necessary, phases out protective relay systems that cannot meet this requirement.”<sup>7</sup> Second, is “...to develop a Reliability Standard addressing undesirable relay operation due to stable power swings.”<sup>8</sup> The third directive “...to consider “islanding” strategies that achieve the fundamental performance for all islands in developing the new Reliability Standard addressing stable power swings”<sup>9</sup> was considered during development of the standard.

The development of this standard implements the majority of the approaches suggested by the report. However, it is noted that the Reliability Coordinator and Transmission Planner have not been included in the standard’s Applicability section (as suggested by the PSRPS Report). This is so that a single entity, the Planning Coordinator, may be the single source for identifying Elements according to Requirement R1. A single source will insure that multiple entities will not identify Elements in duplicate, nor will one entity fail to provide an Element because it believes the Element is being provided by another entity. The Planning Coordinator has, or has access to, the wide-area model and can correctly identify the Elements that may be susceptible to a stable or unstable power swing. Additionally, not including the Reliability Coordinator and Transmission Planner is consistent with the applicability of other relay loadability NERC Reliability Standards (e.g., PRC-023 and PRC-025). It is also consistent with the NERC Functional Model.

The phrase, “while maintaining dependable fault detection and dependable out-of-step tripping” in Requirement R3, describes that the Generator Owner and Transmission Owner are to comply with this standard while achieving its desired protection goals. Load-responsive protective relays, as addressed within this standard, may be intended to provide a variety of backup protection functions, both within the generating unit or generating plant and on the transmission system, and

---

<sup>6</sup> NERC System Protection and Control Subcommittee, *Protection System Response to Power Swings*, August 2013: [http://www.nerc.com/comm/PC/System%20Protection%20and%20Control%20Subcommittee%20SPCS%2020/SPCS%20Power%20Swing%20Report\\_Final\\_20131015.pdf](http://www.nerc.com/comm/PC/System%20Protection%20and%20Control%20Subcommittee%20SPCS%2020/SPCS%20Power%20Swing%20Report_Final_20131015.pdf)

<sup>7</sup> Transmission Relay Loadability Reliability Standard, Order No. 733, P.150 FERC ¶ 61,221 (2010).

<sup>8</sup> Ibid. P.153.

<sup>9</sup> Ibid. P.162.

this standard is not intended to result in the loss of these protection functions. Instead, the Generator Owner and Transmission Owner must consider both the Requirements within this standard and its desired protection goals and perform modifications to its protective relays or protection philosophies as necessary to achieve both.

### Power Swings

The IEEE Power System Relaying Committee WG D6 developed a technical document called *Power Swing and Out-of-Step Considerations on Transmission Lines* (July 2005) that provides background on power swings. The following are general definitions from that document:<sup>10</sup>

**Power Swing:** a variation in three phase power flow which occurs when the generator rotor angles are advancing or retarding relative to each other in response to changes in load magnitude and direction, line switching, loss of generation, faults, and other system disturbances.

**Pole Slip:** a condition whereby a generator, or group of generators, terminal voltage angles (or phases) go past 180 degrees with respect to the rest of the connected power system.

**Stable Power Swing:** a power swing is considered stable if the generators do not slip poles and the system reaches a new state of equilibrium, i.e. an acceptable operating condition.

**Unstable Power Swing:** a power swing that will result in a generator or group of generators experiencing pole slipping for which some corrective action must be taken.

**Out-of-Step Condition:** Same as an unstable power swing.

**Electrical System Center or Voltage Zero:** it is the point or points in the system where the voltage becomes zero during an unstable power swing.

### Burden to Entities

The PSRPS Report provides a technical basis and approach for focusing on Protection Systems, which are susceptible to power swings, while achieving the purpose of the standard. The approach reduces the number of relays to which the PRC-026-1 Requirements would apply by first identifying the BES Element(s) on which load-responsive protective relays must be evaluated. The first step uses criteria to identify the Elements on which a Protection System is expected to be challenged by power swings. Of those Elements, the second step is to evaluate each load-responsive protective relay that is applied on each identified Element. Rather than requiring the Planning Coordinator or Transmission Planner to perform simulations to obtain information for each identified Element, the Generator Owner and Transmission Owner will reduce the need for simulation by comparing the load-responsive protective relay characteristic to specific criteria in PRC-026-1 – Attachment B.

---

<sup>10</sup> <http://www.pes-psrc.org/Reports/Power%20Swing%20and%20OOS%20Considerations%20on%20Transmission%20Lines%20F..pdf>.



### Applicability

The standard is applicable to the Generator Owner, Planning Coordinator, and Transmission Owner entities. More specifically, the Generator Owner and Transmission Owner entities are applicable when applying load-responsive protective relays at the terminals of the applicable BES Elements. The standard is applicable to the following BES Elements: generators, transformers, and transmission lines. The Distribution Provider was considered for inclusion in the standard; however, it is not subject to the standard because this entity, by functional registration, would not own generators, transmission lines, or transformers other than load serving.

Load-responsive protective relays include any protective functions which could trip with or without time delay, on load current.

### Requirement R1

The Planning Coordinator has a wide-area view and is in the position to identify what, if any, Elements meet the criteria. The criterion-based approach is consistent with the NERC System Protection and Control Subcommittee (SPCS) technical document, *Protection System Response to Power Swings* (August 2013),<sup>11</sup> which recommends a focused approach to determine an at-risk Element. Identification of Elements comes from the annual Planning Assessments pursuant to the transmission planning (i.e., “TPL”) and other NERC Reliability Standards (e.g., PRC-006), and the standard is not requiring any other assessments to be performed by the Planning Coordinator. The required notification on a calendar year basis to the respective Generator Owner and Transmission Owner is sufficient because it is expected that the Planning Coordinator will make its notifications following the completion of its annual Planning Assessments. The Planning Coordinator will continue to provide notification of Elements on a calendar year basis even if a study is performed less frequently (e.g., PRC-006 – Automatic Underfrequency Load Shedding, which is five years) and has not changed. It is possible that a Planning Coordinator could utilize studies from a prior year in determining the necessary notifications pursuant to Requirement R1.

### Criterion 1

The first criterion involves generator(s) where an angular stability constraint exists that is addressed by a System Operating Limit (SOL) or a Remedial Action Scheme (RAS) and those Elements terminating at the Transmission station associated with the generator(s). For example, a scheme to remove generation for specific conditions is implemented for a four-unit generating plant (1,100 MW). Two of the units are 500 MW each; one is connected to the 345 kV system and one is connected to the 230 kV system. The Transmission Owner has two 230 kV transmission lines and one 345 kV transmission line all terminating at the generating facility as well as a 345/230 kV autotransformer. The remaining 100 MW consists of two 50 MW combustion turbine (CT) units connected to four 66 kV transmission lines. The 66 kV transmission lines are not electrically joined to the 345 kV and 230 kV transmission lines at the plant site and are not subject to the operating limit or RAS. A stability constraint limits the output of the portion of the plant affected

---

<sup>11</sup> [http://www.nerc.com/comm/PC/System%20Protection%20and%20Control%20Subcommittee%20SPCS%2020/SPCS%20Power%20Swing%20Report\\_Final\\_20131015.pdf](http://www.nerc.com/comm/PC/System%20Protection%20and%20Control%20Subcommittee%20SPCS%2020/SPCS%20Power%20Swing%20Report_Final_20131015.pdf)

by the RAS to 700 MW for an outage of the 345 kV transmission line. The RAS trips one of the 500 MW units to maintain stability for a loss of the 345 kV transmission line when the total output from both 500 MW units is above 700 MW. For this example, both 500 MW generating units and the associated generator step-up (GSU) transformers would be identified as Elements meeting this criterion. The 345/230 kV autotransformer, the 345 kV transmission line, and the two 230 kV transmission lines would also be identified as Elements meeting this criterion. The 50 MW combustion turbines and 66 kV transmission lines would not be identified pursuant to Criterion 1 because these Elements are not subject to an operating limit or RAS and do not terminate at the Transmission station associated with the generators that are subject to the SOL or RAS.

### Criterion 2

The second criterion involves Elements that are monitored as a part of an established System Operating Limit (SOL) based on an angular stability limit regardless of the outage conditions that result in the enforcement of the SOL. For example, if two long parallel 500 kV transmission lines have a combined SOL of 1,200 MW, and this limit is based on angular instability resulting from a fault and subsequent loss of one of the two lines, then both lines would be identified as Elements meeting the criterion.

### Criterion 3

The third criterion involves Elements that form the boundary of an island within an underfrequency load shedding (UFLS) design assessment. The criterion applies to islands identified based on application of the Planning Coordinator's criteria for identifying islands, where the island is formed by tripping the Elements based on angular instability. The criterion applies if the angular instability is modeled in the UFLS design assessment, or if the boundary is identified "off-line" (i.e., the Elements are selected based on angular instability considerations, but the Elements are tripped in the UFLS design assessment without modeling the initiating angular instability). In cases where an out-of-step condition is detected and tripping is initiated at an alternate location, the criterion applies to the Element on which the power swing is detected. The criterion does not apply to islands identified based on other considerations that do not involve angular instability, such as excessive loading, Planning Coordinator area boundary tie lines, or Balancing Authority boundary tie lines.

### Criterion 4

The fourth criterion involves Elements identified in the most recent annual Planning Assessment where relay tripping occurs due to a stable or unstable<sup>12</sup> power swing during a simulated disturbance. The intent is for the Planning Coordinator to include any Element(s) where relay tripping was observed during simulations performed for the most recent annual Planning Assessment associated with the transmission planning TPL-001-4 Reliability Standard. Note that relay tripping must be assessed within those annual Planning Assessments per TPL-001-4, R4,

---

<sup>12</sup> Refer to the "Justification for Including Unstable Power Swings in the Requirements" section.

Part 4.3.1.3, which indicates that analysis shall include the “Tripping of Transmission lines and transformers where transient swings cause Protection System operation based on generic or actual relay models.” Identifying such Elements according to Criterion 4 and notifying the respective Generator Owner and Transmission Owner will require that the owners of any load-responsive protective relay applied at the terminals of the identified Element evaluate the relay’s susceptibility to tripping in response to a stable power swing.

Planning Coordinators have the discretion to determine whether the observed tripping for a power swing in its Planning Assessments occurs for valid contingencies and system conditions. The Planning Coordinator will address tripping that is observed in transient analyses on an individual basis; therefore, the Planning Coordinator is responsible for identifying the Elements based only on simulation results that are determined to be valid.

Due to the nature of how a Planning Assessment is performed, there may be cases where a previously-identified Element is not identified in the most recent annual Planning Assessment. If so, this is acceptable because the Generator Owner and Transmission Owner would have taken action upon the initial notification of the previously identified Element. When an Element is not identified in later Planning Assessments, the risk of load-responsive protective relays tripping in response to a stable power swing during non-Fault conditions would have already been assessed under Requirement R2 and mitigated according to Requirements R3 and R4 where the relays did not meet the PRC-026-1 – Attachment B criteria. According to Requirement R2, the Generator Owner and Transmission Owner are only required to re-evaluate each load-responsive protective relay for an identified Element where the evaluation has not been performed in the last five calendar years.

Although Requirement R1 requires the Planning Coordinator to notify the respective Generator Owner and Transmission Owner of any Elements meeting one or more of the four criteria, it does not preclude the Planning Coordinator from providing additional information, such as apparent impedance characteristics, in advance or upon request, that may be useful in evaluating protective relays. Generator Owners and Transmission Owners are able to complete protective relay evaluations and perform the required actions without additional information. The standard does not include any requirement for the entities to provide information that is already being shared or exchanged between entities for operating needs. While a Requirement has not been included for the exchange of information, entities should recognize that relay performance needs to be measured against the most current information.

### **Requirement R2**

Requirement R2 requires the Generator Owner and Transmission Owner to evaluate its load-responsive protective relays to ensure that they are expected to not trip in response to stable power swings.

## PRC-026-1 – Application Guidelines

---

The PRC-026-1 – Attachment A lists the applicable load-responsive relays that must be evaluated which include phase distance, phase overcurrent, out-of-step tripping, and loss-of-field relay functions. Phase distance relays could include, but are not limited to, the following:

- Zone elements with instantaneous tripping or intentional time delays of less than 15 cycles
- Phase distance elements used in high-speed communication-aided tripping schemes including:
  - Directional Comparison Blocking (DCB) schemes
  - Directional Comparison Un-Blocking (DCUB) schemes
  - Permissive Overreach Transfer Trip (POTT) schemes
  - Permissive Underreach Transfer Trip (PUTT) schemes

A method is provided within the standard to support consistent evaluation by Generator Owners and Transmission Owners based on specified conditions. Once a Generator Owner or Transmission Owner is notified of Elements pursuant to Requirement R1, it has 12 full calendar months to determine if each Element's load-responsive protective relays meet the PRC-026-1 – Attachment B criteria, if the determination has not been performed in the last five calendar years. Additionally, each Generator Owner and Transmission Owner, that becomes aware of a generator, transformer, or transmission line BES Element that tripped in response to a stable or unstable power swing due to the operation of its protective relays pursuant to Requirement R2, Part 2.2, must perform the same PRC-026-1 – Attachment B criteria determination within 12 full calendar months.

### **Becoming Aware of an Element That Tripped in Response to a Power Swing**

Part 2.2 in Requirement R2 is intended to initiate action by the Generator Owner and Transmission Owner when there is a known stable or unstable power swing and it resulted in the entity's Element tripping. The criterion starts with becoming aware of the event (i.e., power swing) and then any connection with the entity's Element tripping. By doing so, the focus is removed from the entity having to demonstrate that it made a determination whether a power swing was present for every Element trip. The basis for structuring the criterion in this manner is driven by the available ways that a Generator Owner and Transmission Owner could become aware of an Element that tripped in response to a stable or unstable power swing due to the operation of its protective relay(s).

Element trips caused by stable or unstable power swings, though infrequent, would be more common in a larger event. The identification of power swings will be revealed during an analysis of the event. Event analysis where an entity may become aware of a stable or unstable power swing could include internal analysis conducted by the entity, the entity's Protection System review following a trip, or a larger scale analysis by other entities. Event analysis could include involvement by the entity's Regional Entity, and in some cases NERC.

### **Information Common to Both Generation and Transmission Elements**

The PRC-026-1 – Attachment A lists the load-responsive protective relays that are subject to this standard. Generator Owners and Transmission Owners may own load-responsive protective relays (e.g., distance relays) that directly affect generation or transmission BES Elements and will require analysis as a result of Elements being identified by the Planning Coordinator in Requirement R1

or the Generator Owner or Transmission Owner in Requirement R2. For example, distance relays owned by the Transmission Owner may be installed at the high-voltage side of the generator step-up (GSU) transformer (directional toward the generator) providing backup to generation protection. Generator Owners may have distance relays applied to backup transmission protection or backup protection to the GSU transformer. The Generator Owner may have relays installed at the generator terminals or the high-voltage side of the GSU transformer.

### Exclusion of Time Based Load-Responsive Protective Relays

The purpose of the standard is “[t]o ensure that load-responsive protective relays are expected to not trip in response to stable power swings during non-Fault conditions.” Load-responsive, high-speed tripping protective relays pose the highest risk of operating during a power swing. Because of this, high-speed tripping protective relays and relays with a time delay of less than 15 cycles are included in the standard; whereas other relays (i.e., Zones 2 and 3) with a time delay of 15 cycles or greater are excluded. The time delay used for exclusion on some load-responsive protective relays is based on the maximum expected time that load-responsive protective relays would be exposed to a stable power swing with a slow slip rate frequency.

In order to establish a time delay that distinguishes a high-risk load-responsive protective relay from one that has a time delay for tripping (lower-risk), a sample of swing rates were calculated based on a stable power swing entering and leaving the impedance characteristic as shown in Table 1. For a relay impedance characteristic that has a power swing entering and leaving, beginning at 90 degrees with a termination at 120 degrees before exiting the zone, the zone timer must be greater than the calculated time the stable power swing is inside the relay’s operating zone to not trip in response to the stable power swing.

$$\text{Eq. (1)} \quad \text{Zone timer} > 2 \times \left( \frac{(120^\circ - \text{Angle of entry into the relay characteristic}) \times 60}{(360 \times \text{Slip Rate})} \right)$$

Table 1: Swing Rates	
Zone Timer (Cycles)	Slip Rate (Hz)
10	1.00
15	0.67
20	0.50
30	0.33

With a minimum zone timer of 15 cycles, the corresponding slip rate of the system is 0.67 Hz. This represents an approximation of a slow slip rate during a system Disturbance. Longer time delays allow for slower slip rates.

### Application to Transmission Elements

Criterion A in PRC-026-1 – Attachment B describes an unstable power swing region that is formed by the union of three shapes in the impedance (R-X) plane. The first shape is a lower loss-of-synchronism circle based on a ratio of the sending-end to receiving-end voltages of 0.7 (i.e.,  $E_S / E_R = 0.7 / 1.0 = 0.7$ ). The second shape is an upper loss-of-synchronism circle based on a ratio of the sending-end to receiving-end voltages of 1.43 (i.e.,  $E_S / E_R = 1.0 / 0.7 = 1.43$ ). The third shape is a lens that connects the endpoints of the total system impedance together by varying the sending-end and receiving-end system voltages from 0.0 to 1.0 per unit, while maintaining a constant system separation angle across the total system impedance (with the parallel transfer impedance removed—see Figures 1 through 5). The total system impedance is derived from a two-bus equivalent network and is determined by summing the sending-end source impedance, the line impedance (excluding the Thévenin equivalent transfer impedance), and the receiving-end source impedance as shown in Figures 6 and 7. Establishing the total system impedance provides a conservative condition that will maximize the security of the relay against various system conditions. The smallest total system impedance represents a condition where the size of the lens characteristic in the R-X plane is smallest and is a conservative operating point from the standpoint of ensuring a load-responsive protective relay is expected to not trip given a predetermined angular displacement between the sending-end and receiving-end voltages. The smallest total system impedance results when all generation is in service and all transmission BES Elements are modeled in their “normal” system configuration (PRC-026-1 – Attachment B, Criterion A). The parallel transfer impedance is removed to represent a likely condition where parallel Elements may be lost during the disturbance, and the loss of these Elements magnifies the sensitivity of the load-responsive relays on the parallel line by removing the “infeed effect” (i.e., the apparent impedance sensed by the relay is decreased as a result of the loss of the transfer impedance, thus making the relay more likely to trip for a stable power swing—See Figures 13 and 14).

The sending-end and receiving-end source voltages are varied from 0.7 to 1.0 per unit to form the lower and upper loss-of-synchronism circles. The ratio of these two voltages is used in the calculation of the loss-of-synchronism circles, and result in a ratio range from 0.7 to 1.43.

$$\text{Eq. (2)} \quad \frac{E_S}{E_R} = \frac{0.7}{1.0} = 0.7$$

$$\text{Eq. (3):} \quad \frac{E_S}{E_R} = \frac{1.0}{0.7} = 1.43$$

The internal generator voltage during severe power swings or transmission system fault conditions will be greater than zero due to voltage regulator support. The voltage ratio of 0.7 to 1.43 is chosen to be more conservative than the PRC-023<sup>13</sup> and PRC-025<sup>14</sup> NERC Reliability Standards where a lower bound voltage of 0.85 per unit voltage is used. A  $\pm 15\%$  internal generator voltage range was chosen as a conservative voltage range for calculation of the voltage ratio used to calculate the loss-of-synchronism circles. For example, the voltage ratio using these voltages would result in a ratio range from 0.739 to 1.353.

---

<sup>13</sup> Transmission Relay Loadability

<sup>14</sup> Generator Relay Loadability

$$\text{Eq. (4)} \quad \frac{E_S}{E_R} = \frac{0.85}{1.15} = 0.739$$

$$\text{Eq. (5):} \quad \frac{E_S}{E_R} = \frac{1.15}{0.85} = 1.353$$

The lower ratio is rounded down to 0.7 to be more conservative, allowing a voltage range of 0.7 to 1.0 per unit to be used for the calculation of the loss-of-synchronism circles.<sup>15</sup>

When the parallel transfer impedance is included in the model, the division of current through the parallel transfer impedance path results in actual measured relay impedances that are larger than those measured when the parallel transfer impedance is removed (i.e., infeed effect), which would make it more likely for an impedance relay element to be completely contained within the unstable power swing region as shown in Figure 11. If the transfer impedance is included in the evaluation, a distance relay element could be deemed as meeting PRC-026-1 – Attachment B criteria and, in fact would be secure, assuming all Elements were in their normal state. In this case, the distance relay element could trip in response to a stable power swing during an actual event if the system was weakened (i.e., a higher transfer impedance) by the loss of a subset of lines that make up the parallel transfer impedance as shown in Figure 10. This could happen because the subset of lines that make up the parallel transfer impedance tripped on unstable swings, contained the initiating fault, and/or were lost due to operation of breaker failure or remote back-up protection schemes.

Table 10 shows the percent size increase of the lens shape as seen by the relay under evaluation when the parallel transfer impedance is included. The parallel transfer impedance has minimal effect on the apparent size of the lens shape as long as the parallel transfer impedance is at least 10 multiples of the parallel line impedance (less than 5% lens shape expansion), therefore, its removal has minimal impact, but results in a slightly more conservative, smaller lens shape. Parallel transfer impedances of 5 multiples of the parallel line impedance or less result in an apparent lens shape size of 10% or greater as seen by the relay. If two parallel lines and a parallel transfer impedance tie the sending-end and receiving-end buses together, the total parallel transfer impedance will be one or less multiples of the parallel line impedance, resulting in an apparent lens shape size of 45% or greater. It is a realistic contingency that the parallel line could be out-of-service, leaving the parallel transfer impedance making up the rest of the system in parallel with the line impedance. Since it is not known exactly which lines making up the parallel transfer impedance will be out of service during a major system disturbance, it is most conservative to assume that all of them are out, leaving just the line under evaluation in service.

Either the saturated transient or sub-transient direct axis reactance may be used for machines in the evaluation because they are smaller than the un-saturated reactances. Since saturated sub-transient generator reactances are smaller than the transient or synchronous reactances, the use of sub-transient reactances will result in a smaller source impedance and a smaller unstable power swing region in the graphical analysis as shown in Figures 8 and 9. Because power swings occur in a time frame where generator transient reactances will be prevalent, it is acceptable to use saturated transient reactances instead of saturated sub-transient reactances. Because some short-

---

<sup>15</sup> *Final Report on the August 14, 2003 Blackout in the United States and Canada: Causes and Recommendations*, April 2004, Section 6 (The Cascade Stage of the Blackout), p. 94 under “Why the Generators Tripped Off,” states, “Some generator undervoltage relays were set to trip at or above 90% voltage. However, a motor stalls out at about 70% voltage and a motor starter contactor drops out around 75%, so if there is a compelling need to protect the turbine from the system the under-voltage trigger point should be no higher than 80%.”

circuit models may not include transient reactances, the use of sub-transient reactances is also acceptable because it produces more conservative results. For this reason, either value is acceptable when determining the system source impedances (PRC-026-1 – Attachment B, Criterion A and B, No. 3).

Saturated reactances are used in short-circuit programs that produce the system impedance mentioned above. Planning and stability software generally use un-saturated reactances. Generator models used in transient stability analyses recognize that the extent of the saturation effect depends upon both rotor (field) and stator currents. Accordingly, they derive the effective saturated parameters of the machine at each instant by internal calculation from the specified (constant) unsaturated values of machine reactances and the instantaneous internal flux level. The specific assumptions regarding which inductances are affected by saturation, and the relative effect of that saturation, are different for the various generator models used. Thus, unsaturated values of all machine reactances are used in setting up planning and stability software data, and the appropriate set of open-circuit magnetization curve data is provided for each machine.

Saturated reactance values are smaller than unsaturated reactance values and are used in short-circuit programs owned by the Generator and Transmission Owners. Because of this, saturated reactance values are to be used in the development of the system source impedances.

The source or system equivalent impedances can be obtained by a number of different methods using commercially available short-circuit calculation tools.<sup>16</sup> Most short-circuit tools have a network reduction feature that allows the user to select the local and remote terminal buses to retain. The first method reduces the system to one that contains two buses, an equivalent generator at each bus (representing the source impedances at the sending-end and receiving-end), and two parallel lines; one being the line impedance of the protected line with relays being analyzed, the other being the parallel transfer impedance representing all other combinations of lines that connect the two buses together as shown in Figure 6. Another conservative method is to open both ends of the line being evaluated, and apply a three-phase bolted fault at each bus to determine the Thévenin equivalent impedance at each bus. The source impedances are set equal to the Thévenin equivalent impedances and will be less than or equal to the actual source impedances calculated by the network reduction method. Either method can be used to develop the system source impedances at both ends.

The two bullets of PRC-026-1 – Attachment B, Criterion A, No. 1, identify the system separation angles used to identify the size of the power swing stability boundary for evaluating load-responsive protective relay impedance elements. The first bullet of PRC-026-1 – Attachment B, Criterion A, No. 1 evaluates a system separation angle of at least 120 degrees that is held constant while varying the sending-end and receiving-end source voltages from 0.7 to 1.0 per unit, thus creating an unstable power swing region about the total system impedance in Figure 1. This unstable power swing region is compared to the tripping portion of the distance relay characteristic; that is, the portion that is not supervised by load encroachment, blinders, or some other form of supervision as shown in Figure 12 that restricts the distance element from tripping

---

<sup>16</sup> Demetrios A. Tziouvaras and Daqing Hou, Appendix in *Out-Of-Step Protection Fundamentals and Advancements*, April 17, 2014: <https://www.selinc.com>.



## PRC-026-1 – Application Guidelines

---

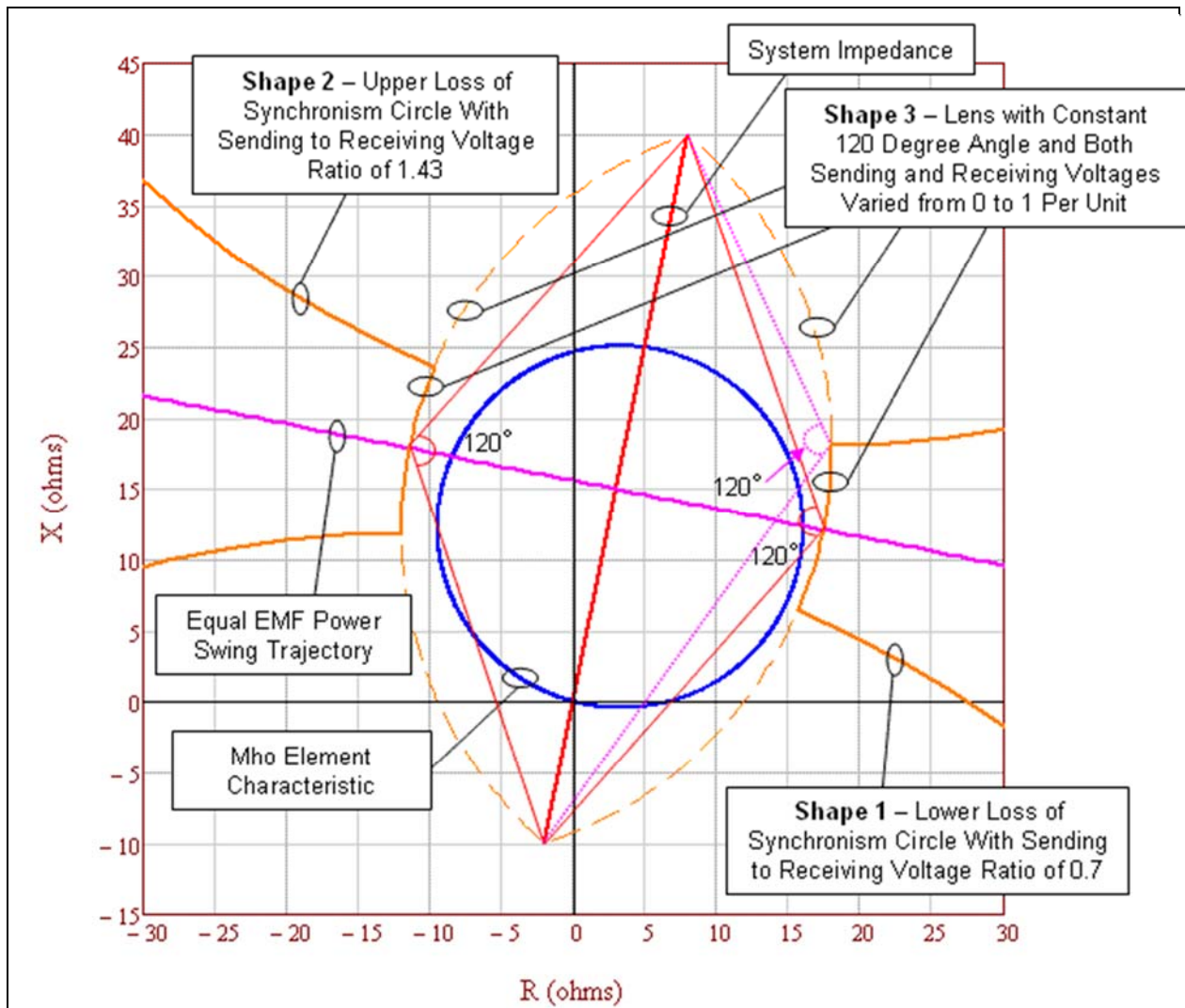
for heavy, balanced load conditions. If the tripping portion of the impedance characteristics are completely contained within the unstable power swing region, the relay impedance element meets Criterion A in PRC-026-1 – Attachment B. A system separation angle of 120 degrees was chosen for the evaluation because it is generally accepted in the industry that recovery for a swing beyond this angle is unlikely to occur.<sup>17</sup>

The second bullet of PRC-026-1 – Attachment B, Criterion A, No. 1 evaluates impedance relay elements at a system separation angle of less than 120 degrees, similar to the first bullet described above. An angle less than 120 degrees may be used if a documented stability analysis demonstrates that the power swing becomes unstable at a system separation angle of less than 120 degrees.

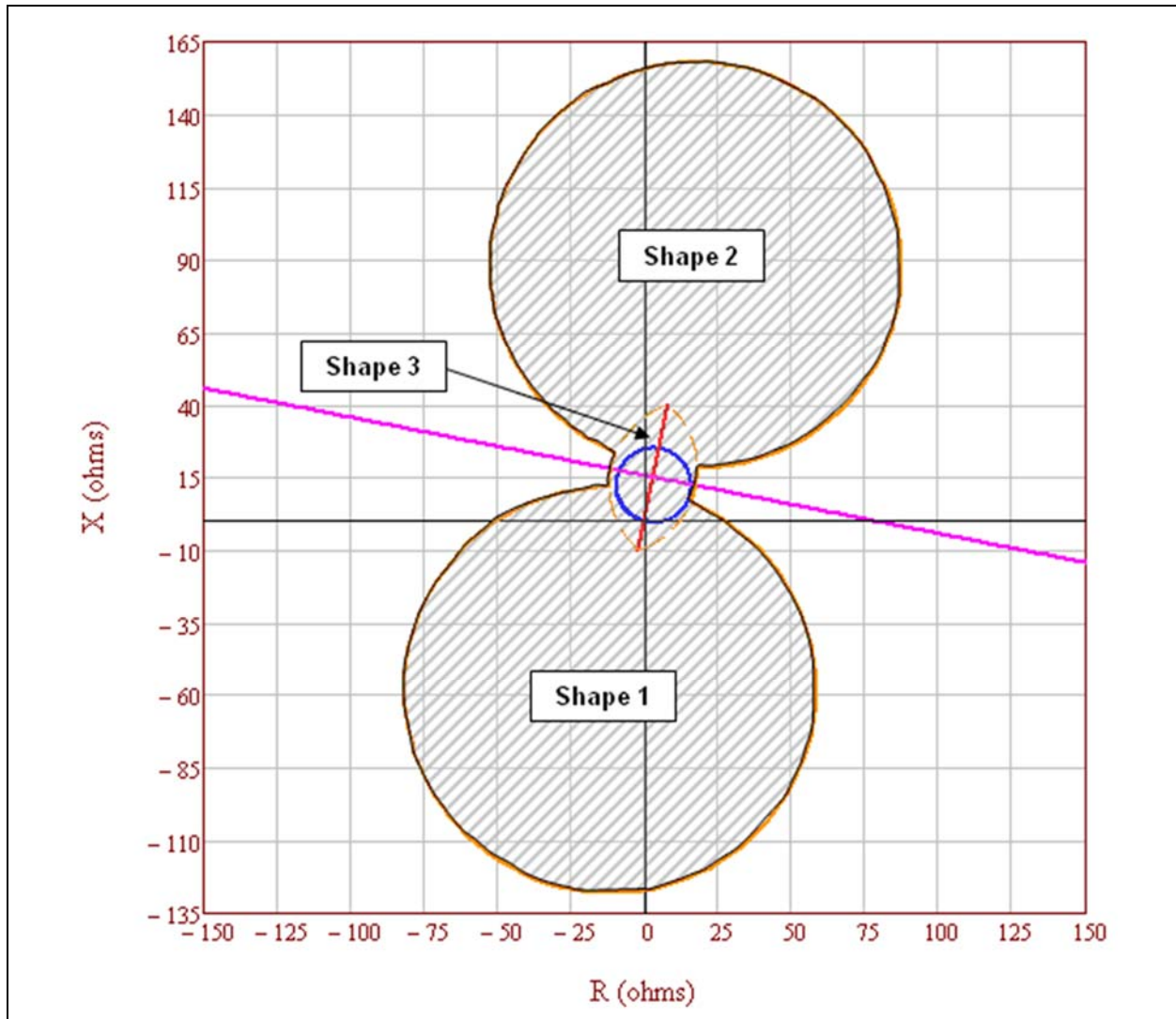
The exclusion of relay elements supervised by Power Swing Blocking (PSB) in PRC-026-1 – Attachment A allows the Generator Owner or Transmission Owner to exclude protective relay elements if they are blocked from tripping by PSB relays. A PSB relay applied and set according to industry accepted practices prevent supervised load-responsive protective relays from tripping in response to power swings. Further, PSB relays are set to allow dependable tripping of supervised elements. The criteria in PRC-026-1 – Attachment B specifically applies to unsupervised elements that could trip for stable power swings. Therefore, load-responsive protective relay elements supervised by PSB can be excluded from the Requirements of this standard.

---

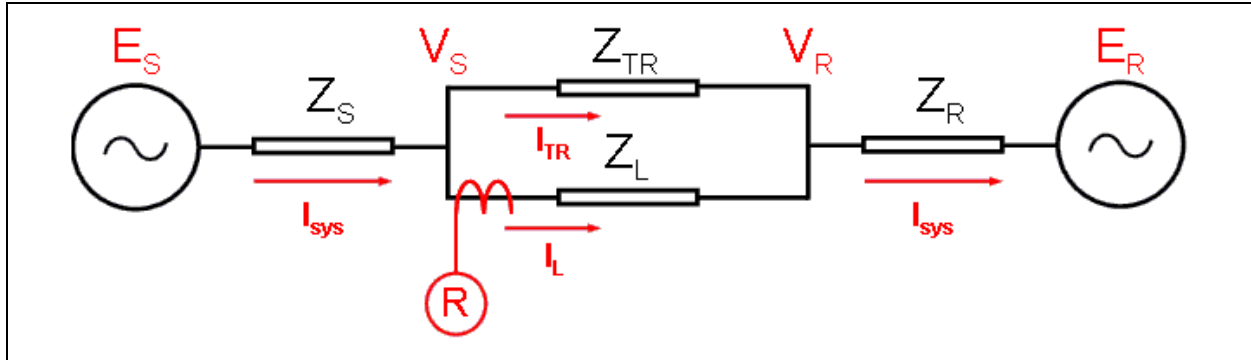
<sup>17</sup> “The critical angle for maintaining stability will vary depending on the contingency and the system condition at the time the contingency occurs; however, the likelihood of recovering from a swing that exceeds 120 degrees is marginal and 120 degrees is generally accepted as an appropriate basis for setting out-of-step protection. Given the importance of separating unstable systems, defining 120 degrees as the critical angle is appropriate to achieve a proper balance between dependable tripping for unstable power swings and secure operation for stable power swings.” NERC System Protection and Control Subcommittee, *Protection System Response to Power Swings*, August 2013: [http://www.nerc.com/comm/PC/System%20Protection%20and%20Control%20Subcommittee%20SPCS%202020/SPCS%20Power%20Swing%20Report\\_Final\\_20131015.pdf](http://www.nerc.com/comm/PC/System%20Protection%20and%20Control%20Subcommittee%20SPCS%202020/SPCS%20Power%20Swing%20Report_Final_20131015.pdf), p. 28.



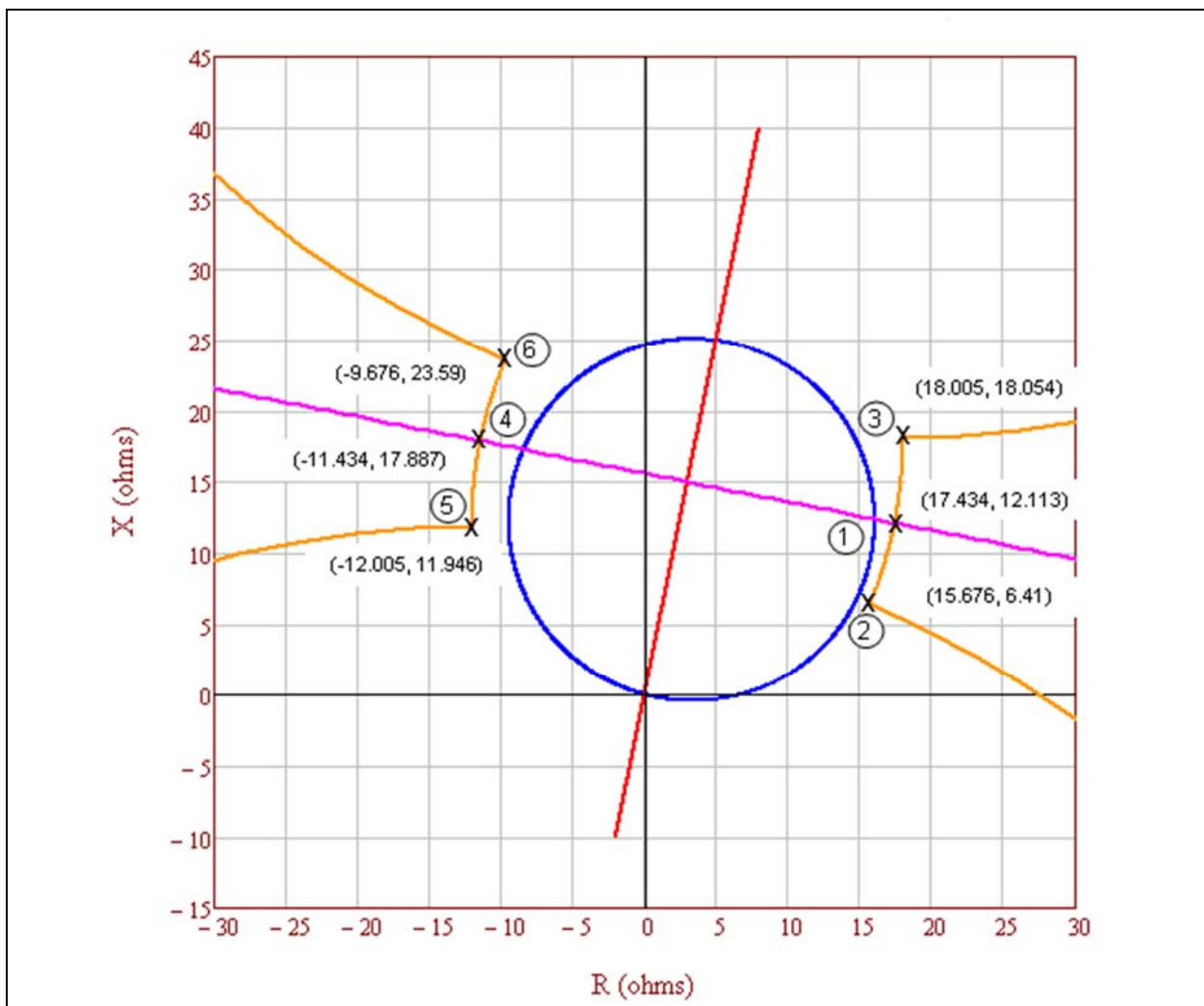
**Figure 1:** An enlarged graphic illustrating the unstable power swing region formed by the union of three shapes in the impedance (R-X) plane: Shape 1) Lower loss-of-synchronism circle, Shape 2) Upper loss-of-synchronism circle, and Shape 3) Lens. The mho element characteristic is completely contained within the unstable power swing region (i.e., it does not intersect any portion of the unstable power swing region), therefore it meets PRC-026-1 – Attachment B, Criterion A, No. 1.



**Figure 2:** Full graphic of the unstable power swing region formed by the union of the three shapes in the impedance (R-X) plane: Shape 1) Lower loss-of-synchronism circle, Shape 2) Upper loss-of-synchronism circle, and Shape 3) Lens. The mho element characteristic is completely contained within the unstable power swing region, therefore it meets PRC-26-1 – Attachment B, Criterion A, No.1.



**Figure 3:** System impedances as seen by Relay R (voltage connections are not shown).



**Figure 4:** The defining unstable power swing region points where the lens shape intersects the lower and upper loss-of-synchronism circle shapes and where the lens intersects the equal EMF (electromotive force) power swing.

E <sub>S</sub> / E <sub>R</sub> Voltage Ratio	Left Side Coordinates		Right Side Coordinates	
	R	+ jX	R	+ jX
<b>0.7</b>	<b>-12.005</b>	<b>11.946</b>	<b>15.676</b>	<b>6.41</b>
0.72	-12.004	12.407	15.852	6.836
0.74	-11.996	12.857	16.018	7.255
0.76	-11.982	13.298	16.175	7.667
0.78	-11.961	13.729	16.321	8.073
0.8	-11.935	14.151	16.459	8.472
0.82	-11.903	14.563	16.589	8.865
0.84	-11.867	14.966	16.71	9.251
0.86	-11.826	15.361	16.824	9.631
0.88	-11.78	15.746	16.93	10.004
0.9	-11.731	16.123	17.03	10.371
0.92	-11.678	16.492	17.123	10.732
0.94	-11.621	16.852	17.209	11.086
0.96	-11.562	17.205	17.29	11.435
0.98	-11.499	17.55	17.364	11.777
<b>1</b>	<b>-11.434</b>	<b>17.887</b>	<b>17.434</b>	<b>12.113</b>
1.0286	-11.336	18.356	17.524	12.584
1.0572	-11.234	18.81	17.604	13.043
1.0858	-11.127	19.251	17.675	13.49
1.1144	-11.017	19.677	17.738	13.926
1.143	-10.904	20.091	17.792	14.351
1.1716	-10.788	20.491	17.84	14.766
1.2002	-10.67	20.88	17.88	15.17
1.2288	-10.55	21.256	17.914	15.564
1.2574	-10.428	21.621	17.942	15.948
1.286	-10.304	21.975	17.964	16.322
1.3146	-10.18	22.319	17.981	16.687
1.3432	-10.054	22.652	17.993	17.043
1.3718	-9.928	22.976	18.001	17.39
1.4004	-9.801	23.29	18.005	17.728
<b>1.429</b>	<b>-9.676</b>	<b>23.59</b>	<b>18.005</b>	<b>18.054</b>

**Figure 5:** Full table of 31 detailed lens shape point calculations. The bold highlighted rows correspond to the detailed calculations in Tables 2-7.

Table 2: Example Calculation (Lens Point 1)	
This example is for calculating the impedance the first point of the lens characteristic. Equal source voltages are used for the 230 kV (base) line with the sending-end voltage (E <sub>S</sub> ) leading the receiving-end voltage (E <sub>R</sub> ) by 120 degrees. See Figures 3 and 4.	
Eq. (6)	$E_S = \frac{V_{LL} \angle 120^\circ}{\sqrt{3}}$

Table 2: Example Calculation (Lens Point 1)			
	$E_S = \frac{230,000 \angle 120^\circ V}{\sqrt{3}}$		
	$E_S = 132,791 \angle 120^\circ V$		
Eq. (7)	$E_R = \frac{V_{LL} \angle 0^\circ}{\sqrt{3}}$		
	$E_R = \frac{230,000 \angle 0^\circ V}{\sqrt{3}}$		
	$E_R = 132,791 \angle 0^\circ V$		
Positive sequence impedance data (with transfer impedance $Z_{TR}$ set to a large value).			
Given:	$Z_S = 2 + j10 \Omega$	$Z_L = 4 + j20 \Omega$	$Z_R = 4 + j20 \Omega$
Given:	$Z_{TR} = Z_L \times 10^{10} \Omega$		
Total impedance between the generators.			
Eq. (8)	$Z_{total} = \frac{(Z_L \times Z_{TR})}{(Z_L + Z_{TR})}$		
	$Z_{total} = \frac{((4 + j20) \Omega \times (4 + j20) \times 10^{10} \Omega)}{((4 + j20) \Omega + (4 + j20) \times 10^{10} \Omega)}$		
	$Z_{total} = 4 + j20 \Omega$		
Total system impedance.			
Eq. (9)	$Z_{sys} = Z_S + Z_{total} + Z_R$		
	$Z_{sys} = (2 + j10) \Omega + (4 + j20) \Omega + (4 + j20) \Omega$		
	$Z_{sys} = 10 + j50 \Omega$		
Total system current from sending-end source.			
Eq. (10)	$I_{sys} = \frac{E_S - E_R}{Z_{sys}}$		
	$I_{sys} = \frac{132,791 \angle 120^\circ V - 132,791 \angle 0^\circ V}{(10 + j50) \Omega}$		
	$I_{sys} = 4,511 \angle 71.3^\circ A$		
The current, as measured by the relay on $Z_L$ (Figure 3), is only the current flowing through that line as determined by using the current divider equation.			
Eq. (11)	$I_L = I_{sys} \times \frac{Z_{TR}}{Z_L + Z_{TR}}$		

Table 2: Example Calculation (Lens Point 1)	
	$I_L = 4,511\angle 71.3^\circ A \times \frac{(4 + j20) \times 10^{10} \Omega}{(4 + j20) \Omega + (4 + j20) \times 10^{10} \Omega}$
	$I_L = 4,511\angle 71.3^\circ A$
The voltage, as measured by the relay on $Z_L$ (Figure 3), is the voltage drop from the sending-end source through the sending-end source impedance.	
Eq. (12)	$V_S = E_S - (Z_S \times I_{sys})$
	$V_S = 132,791\angle 120^\circ V - [(2 + j10) \Omega \times 4,511\angle 71.3^\circ A]$
	$V_S = 95,757\angle 106.1^\circ V$
The impedance seen by the relay on $Z_L$ .	
Eq. (13)	$Z_{L-Relay} = \frac{V_S}{I_L}$
	$Z_{L-Relay} = \frac{95,757\angle 106.1^\circ V}{4,511\angle 71.3^\circ A}$
	$Z_{L-Relay} = 17.434 + j12.113 \Omega$

Table 3: Example Calculation (Lens Point 2)	
This example is for calculating the impedance second point of the lens characteristic. Unequal source voltages are used for the 230 kV (base) line with the sending-end voltage ( $E_S$ ) at 70% of the receiving-end voltage ( $E_R$ ) and leading the receiving-end voltage by 120 degrees. See Figures 3 and 4.	
Eq. (14)	$E_S = \frac{V_{LL}\angle 120^\circ}{\sqrt{3}} \times 70\%$
	$E_S = \frac{230,000\angle 120^\circ V}{\sqrt{3}} \times 0.70$
	$E_S = 92,953.7\angle 120^\circ V$
Eq. (15)	$E_R = \frac{V_{LL}\angle 0^\circ}{\sqrt{3}}$
	$E_R = \frac{230,000\angle 0^\circ V}{\sqrt{3}}$
	$E_R = 132,791\angle 0^\circ V$
Positive sequence impedance data (with transfer impedance $Z_{TR}$ set to a large value).	
Given:	$Z_S = 2 + j10 \Omega$ $Z_L = 4 + j20 \Omega$ $Z_R = 4 + j20 \Omega$
Given:	$Z_{TR} = Z_L \times 10^{10} \Omega$

Table 3: Example Calculation (Lens Point 2)	
Total impedance between the generators.	
Eq. (16)	$Z_{total} = \frac{(Z_L \times Z_{TR})}{(Z_L + Z_{TR})}$
	$Z_{total} = \frac{((4 + j20) \Omega \times (4 + j20) \times 10^{10} \Omega)}{((4 + j20) \Omega + (4 + j20) \times 10^{10} \Omega)}$
	$Z_{total} = 4 + j20 \Omega$
Total system impedance.	
Eq. (17)	$Z_{sys} = Z_S + Z_{total} + Z_R$
	$Z_{sys} = (2 + j10) \Omega + (4 + j20) \Omega + (4 + j20) \Omega$
	$Z_{sys} = 10 + j50 \Omega$
Total system current from sending-end source.	
Eq. (18)	$I_{sys} = \frac{E_S - E_R}{Z_{sys}}$
	$I_{sys} = \frac{92,953.7 \angle 120^\circ V - 132,791 \angle 0^\circ V}{(10 + j50) \Omega}$
	$I_{sys} = 3,854 \angle 77^\circ A$
The current, as measured by the relay on Z <sub>L</sub> (Figure 3), is only the current flowing through that line as determined by using the current divider equation.	
Eq. (19)	$I_L = I_{sys} \times \frac{Z_{TR}}{Z_L + Z_{TR}}$
	$I_L = 3,854 \angle 77^\circ A \times \frac{(4 + j20) \times 10^{10} \Omega}{(4 + j20) \Omega + (4 + j20) \times 10^{10} \Omega}$
	$I_L = 3,854 \angle 77^\circ A$
The voltage, as measured by the relay on Z <sub>L</sub> (Figure 3), is the voltage drop from the sending-end source through the sending-end source impedance.	
Eq. (20)	$V_S = E_S - (Z_S \times I_{sys})$
	$V_S = 92,953 \angle 120^\circ V - [(2 + j10) \Omega \times 3,854 \angle 77^\circ A]$
	$V_S = 65,271 \angle 99^\circ V$
The impedance seen by the relay on Z <sub>L</sub> .	
Eq. (21)	$Z_{L-Relay} = \frac{V_S}{I_L}$



Table 3: Example Calculation (Lens Point 2)	
	$Z_{L-Relay} = \frac{65,271 \angle 99^\circ V}{3,854 \angle 77^\circ A}$
	$Z_{L-Relay} = 15.676 + j6.41 \Omega$

Table 4: Example Calculation (Lens Point 3)			
This example is for calculating the impedance third point of the lens characteristic. Unequal source voltages are used for the 230 kV (base) line with the receiving-end voltage ( $E_R$ ) at 70% of the sending-end voltage ( $E_S$ ) and the sending-end voltage leading the receiving-end voltage by 120 degrees. See Figures 3 and 4.			
Eq. (22)	$E_S = \frac{V_{LL} \angle 120^\circ}{\sqrt{3}}$		
	$E_S = \frac{230,000 \angle 120^\circ V}{\sqrt{3}}$		
	$E_S = 132,791 \angle 120^\circ V$		
Eq. (23)	$E_R = \frac{V_{LL} \angle 0^\circ}{\sqrt{3}} \times 70\%$		
	$E_R = \frac{230,000 \angle 0^\circ V}{\sqrt{3}} \times 0.70$		
	$E_R = 92,953.7 \angle 0^\circ V$		
Positive sequence impedance data (with transfer impedance $Z_{TR}$ set to a large value).			
Given:	$Z_S = 2 + j10 \Omega$	$Z_L = 4 + j20 \Omega$	$Z_R = 4 + j20 \Omega$
Given:	$Z_{TR} = Z_L \times 10^{10} \Omega$		
Total impedance between the generators.			
Eq. (24)	$Z_{total} = \frac{(Z_L \times Z_{TR})}{(Z_L + Z_{TR})}$		
	$Z_{total} = \frac{((4 + j20) \Omega \times (4 + j20) \times 10^{10} \Omega)}{((4 + j20) \Omega + (4 + j20) \times 10^{10} \Omega)}$		
	$Z_{total} = 4 + j20 \Omega$		
Total system impedance.			
Eq. (25)	$Z_{sys} = Z_S + Z_{total} + Z_R$		
	$Z_{sys} = (2 + j10) \Omega + (4 + j20) \Omega + (4 + j20) \Omega$		
	$Z_{sys} = 10 + j50 \Omega$		

Table 4: Example Calculation (Lens Point 3)	
Total system current from sending-end source.	
Eq. (26)	$I_{sys} = \frac{E_S - E_R}{Z_{sys}}$
	$I_{sys} = \frac{132,791 \angle 120^\circ V - 92,953.7 \angle 0^\circ V}{(10 + j50) \Omega}$
	$I_{sys} = 3,854 \angle 65.5^\circ A$
The current, as measured by the relay on Z <sub>L</sub> (Figure 3), is only the current flowing through that line as determined by using the current divider equation.	
Eq. (27)	$I_L = I_{sys} \times \frac{Z_{TR}}{Z_L + Z_{TR}}$
	$I_L = 3,854 \angle 65.5^\circ A \times \frac{(4 + j20) \times 10^{10} \Omega}{(4 + j20) \Omega + (4 + j20) \times 10^{10} \Omega}$
	$I_L = 3,854 \angle 65.5^\circ A$
The voltage, as measured by the relay on Z <sub>L</sub> (Figure 3), is the voltage drop from the sending-end source through the sending-end source impedance.	
Eq. (28)	$V_S = E_S - (Z_S \times I_L)$
	$V_S = 132,791 \angle 120^\circ V - [(2 + j10) \Omega \times 3,854 \angle 65.5^\circ A]$
	$V_S = 98,265 \angle 110.6^\circ V$
The impedance seen by the relay on Z <sub>L</sub> .	
Eq. (29)	$Z_{L-Relay} = \frac{V_S}{I_L}$
	$Z_{L-Relay} = \frac{98,265 \angle 110.6^\circ V}{3,854 \angle 65.5^\circ A}$
	$Z_{L-Relay} = 18.005 + j18.054 \Omega$

Table 5: Example Calculation (Lens Point 4)	
This example is for calculating the impedance fourth point of the lens characteristic. Equal source voltages are used for the 230 kV (base) line with the sending-end voltage (E <sub>S</sub> ) leading the receiving-end voltage (E <sub>R</sub> ) by 240 degrees. See Figures 3 and 4.	
Eq. (30)	$E_S = \frac{V_{LL} \angle 240^\circ}{\sqrt{3}}$
	$E_S = \frac{230,000 \angle 240^\circ V}{\sqrt{3}}$

Table 5: Example Calculation (Lens Point 4)			
	$E_S = 132,791 \angle 240^\circ V$		
Eq. (31)	$E_R = \frac{V_{LL} \angle 0^\circ}{\sqrt{3}}$		
	$E_R = \frac{230,000 \angle 0^\circ V}{\sqrt{3}}$		
	$E_R = 132,791 \angle 0^\circ V$		
Positive sequence impedance data (with transfer impedance $Z_{TR}$ set to a large value).			
Given:	$Z_S = 2 + j10 \Omega$	$Z_L = 4 + j20 \Omega$	$Z_R = 4 + j20 \Omega$
Given:	$Z_{TR} = Z_L \times 10^{10} \Omega$		
Total impedance between the generators.			
Eq. (32)	$Z_{total} = \frac{(Z_L \times Z_{TR})}{(Z_L + Z_{TR})}$		
	$Z_{total} = \frac{((4 + j20) \Omega \times (4 + j20) \times 10^{10} \Omega)}{((4 + j20) \Omega + (4 + j20) \times 10^{10} \Omega)}$		
	$Z_{total} = 4 + j20 \Omega$		
Total system impedance.			
Eq. (33)	$Z_{sys} = Z_S + Z_{total} + Z_R$		
	$Z_{sys} = (2 + j10) \Omega + (4 + j20) \Omega + (4 + j20) \Omega$		
	$Z_{sys} = 10 + j50 \Omega$		
Total system current from sending-end source.			
Eq. (34)	$I_{sys} = \frac{E_S - E_R}{Z_{sys}}$		
	$I_{sys} = \frac{132,791 \angle 240^\circ V - 132,791 \angle 0^\circ V}{(10 + j50) \Omega}$		
	$I_{sys} = 4,511 \angle 131.3^\circ A$		
The current, as measured by the relay on $Z_L$ (Figure 3), is only the current flowing through that line as determined by using the current divider equation.			
Eq. (35)	$I_L = I_{sys} \times \frac{Z_{TR}}{Z_L + Z_{TR}}$		
	$I_L = 4,511 \angle 131.1^\circ A \times \frac{(4 + j20) \times 10^{10} \Omega}{(4 + j20) \Omega + (4 + j20) \times 10^{10} \Omega}$		
	$I_L = 4,511 \angle 131.1^\circ A$		

**Table 5: Example Calculation (Lens Point 4)**

The voltage, as measured by the relay on $Z_L$ (Figure 3), is the voltage drop from the sending-end source through the sending-end source impedance.	
Eq. (36)	$V_S = E_S - (Z_S \times I_L)$
	$V_S = 132,791 \angle 240^\circ V - [(2 + j10) \Omega \times 4,511 \angle 131.1^\circ A]$
	$V_S = 95,756 \angle -106.1^\circ V$
The impedance seen by the relay on $Z_L$ .	
Eq. (37)	$Z_{L-Relay} = \frac{V_S}{I_L}$
	$Z_{L-Relay} = \frac{95,756 \angle -106.1^\circ V}{4,511 \angle 131.1^\circ A}$
	$Z_{L-Relay} = -11.434 + j17.887 \Omega$

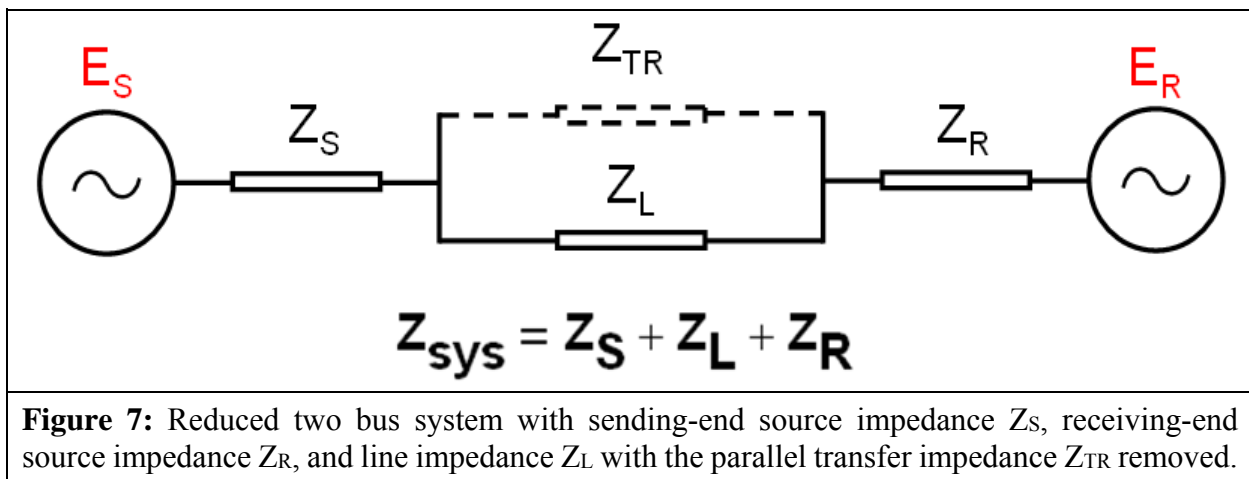
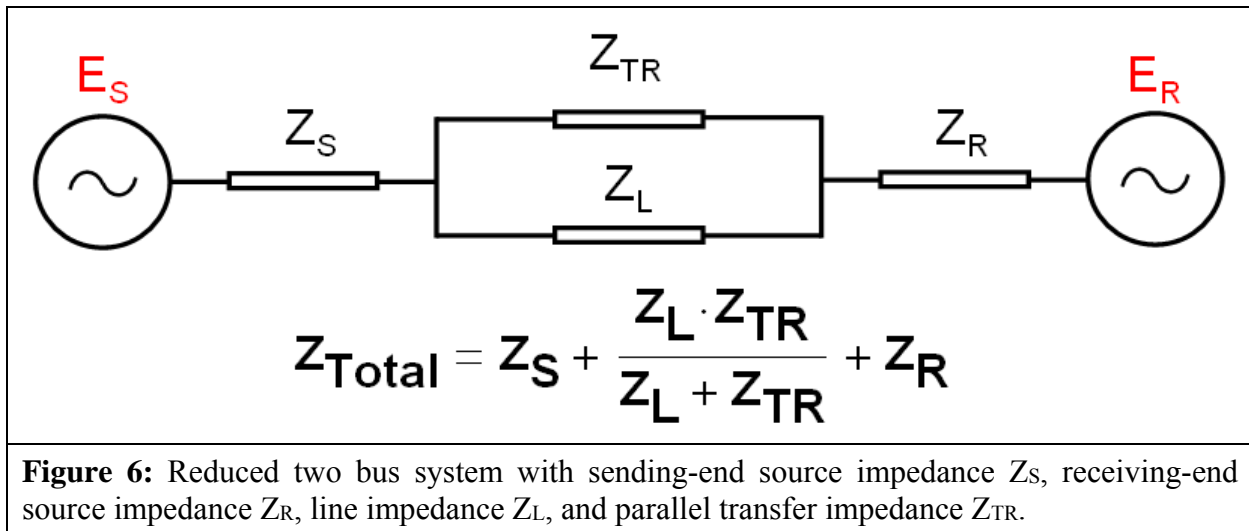
**Table 6: Example Calculation (Lens Point 5)**

This example is for calculating the impedance fifth point of the lens characteristic. Unequal source voltages are used for the 230 kV (base) line with the sending-end voltage ( $E_S$ ) at 70% of the receiving-end voltage ( $E_R$ ) and leading the receiving-end voltage by 240 degrees. See Figures 3 and 4.	
Eq. (38)	$E_S = \frac{V_{LL} \angle 240^\circ}{\sqrt{3}} \times 70\%$
	$E_S = \frac{230,000 \angle 240^\circ V}{\sqrt{3}} \times 0.70$
	$E_S = 92,953.7 \angle 240^\circ V$
Eq. (39)	$E_R = \frac{V_{LL} \angle 0^\circ}{\sqrt{3}}$
	$E_R = \frac{230,000 \angle 0^\circ V}{\sqrt{3}}$
	$E_R = 132,791 \angle 0^\circ V$
Positive sequence impedance data (with transfer impedance $Z_{TR}$ set to a large value).	
Given:	$Z_S = 2 + j10 \Omega$ $Z_L = 4 + j20 \Omega$ $Z_R = 4 + j20 \Omega$
Given:	$Z_{TR} = Z_L \times 10^{10} \Omega$
Total impedance between the generators.	
Eq. (40)	$Z_{total} = \frac{(Z_L \times Z_{TR})}{(Z_L + Z_{TR})}$

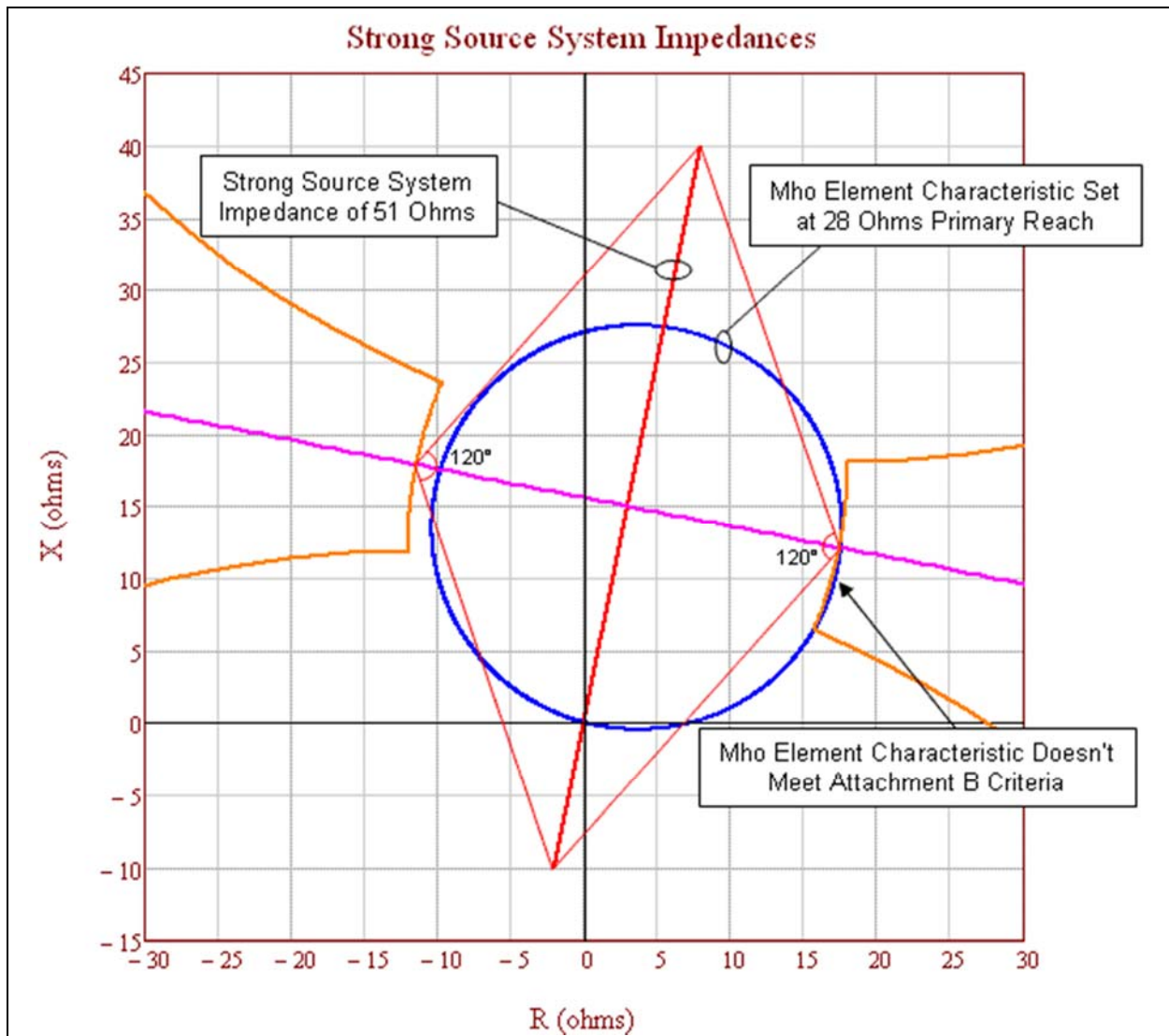
Table 6: Example Calculation (Lens Point 5)	
	$Z_{total} = \frac{((4 + j20) \Omega \times (4 + j20) \times 10^{10} \Omega)}{((4 + j20) \Omega + (4 + j20) \times 10^{10} \Omega)}$
	$Z_{total} = 4 + j20 \Omega$
Total system impedance.	
Eq. (41)	$Z_{sys} = Z_S + Z_{total} + Z_R$
	$Z_{sys} = (2 + j10 \Omega) + (4 + j20 \Omega) + (4 + j20 \Omega)$
	$Z_{sys} = 10 + j50 \Omega$
Total system current from sending-end source.	
Eq. (42)	$I_{sys} = \frac{E_S - E_R}{Z_{sys}}$
	$I_{sys} = \frac{92,953.7 \angle 240^\circ V - 132,791 \angle 0^\circ V}{10 + j50 \Omega}$
	$I_{sys} = 3,854 \angle 125.5^\circ A$
The current, as measured by the relay on $Z_L$ (Figure 3), is only the current flowing through that line as determined by using the current divider equation.	
Eq. (43)	$I_L = I_{sys} \times \frac{Z_{TR}}{Z_L + Z_{TR}}$
	$I_L = 3,854 \angle 125.5^\circ A \times \frac{(4 + j20) \times 10^{10} \Omega}{(4 + j20) \Omega + (4 + j20) \times 10^{10} \Omega}$
	$I_L = 3,854 \angle 125.5^\circ A$
The voltage, as measured by the relay on $Z_L$ (Figure 3), is the voltage drop from the sending-end source through the sending-end source impedance.	
Eq. (44)	$V_S = E_S - (Z_S \times I_L)$
	$V_S = 92,953.7 \angle 240^\circ V - [(2 + j10) \Omega \times 3,854 \angle 125.5^\circ A]$
	$V_S = 65,270.5 \angle -99.4^\circ V$
The impedance seen by the relay on $Z_L$ .	
Eq. (45)	$Z_{L-Relay} = \frac{V_S}{I_L}$
	$Z_{L-Relay} = \frac{65,270.5 \angle -99.4^\circ V}{3,854 \angle 125.5^\circ A}$
	$Z_{L-Relay} = -12.005 + j11.946 \Omega$

Table 7: Example Calculation (Lens Point 6)			
This example is for calculating the impedance sixth point of the lens characteristic. Unequal source voltages are used for the 230 kV (base) line with the receiving-end voltage ( $E_R$ ) at 70% of the sending-end voltage ( $E_S$ ) and the sending-end voltage leading the receiving-end voltage by 240 degrees. See Figures 3 and 4.			
Eq. (46)	$E_S = \frac{V_{LL} \angle 240^\circ}{\sqrt{3}}$		
	$E_S = \frac{230,000 \angle 240^\circ V}{\sqrt{3}}$		
	$E_S = 132,791 \angle 240^\circ V$		
Eq. (47)	$E_R = \frac{V_{LL} \angle 0^\circ}{\sqrt{3}} \times 70\%$		
	$E_R = \frac{230,000 \angle 0^\circ V}{\sqrt{3}} \times 0.70$		
	$E_R = 92,953.7 \angle 0^\circ V$		
Positive sequence impedance data (with transfer impedance $Z_{TR}$ set to a large value).			
Given:	$Z_S = 2 + j10 \Omega$	$Z_L = 4 + j20 \Omega$	$Z_R = 4 + j20 \Omega$
Given:	$Z_{TR} = Z_L \times 10^{10} \Omega$		
Total impedance between the generators.			
Eq. (48)	$Z_{total} = \frac{(Z_L \times Z_{TR})}{(Z_L + Z_{TR})}$		
	$Z_{total} = \frac{((4 + j20) \Omega \times (4 + j20) \times 10^{10} \Omega)}{((4 + j20) \Omega + (4 + j20) \times 10^{10} \Omega)}$		
	$Z_{total} = 4 + j20 \Omega$		
Total system impedance.			
Eq. (49)	$Z_{sys} = Z_S + Z_{total} + Z_R$		
	$Z_{sys} = (2 + j10) \Omega + (4 + j20) \Omega + (4 + j20) \Omega$		
	$Z_{sys} = 10 + j50 \Omega$		
Total system current from sending-end source.			
Eq. (50)	$I_{sys} = \frac{E_S - E_R}{Z_{sys}}$		
	$I_{sys} = \frac{132,791 \angle 240^\circ V - 92,953.7 \angle 0^\circ V}{10 + j50 \Omega}$		
	$I_{sys} = 3,854 \angle 137.1^\circ A$		

Table 7: Example Calculation (Lens Point 6)	
The current, as measured by the relay on $Z_L$ (Figure 3), is only the current flowing through that line as determined by using the current divider equation.	
Eq. (51)	$I_L = I_{sys} \times \frac{Z_{TR}}{Z_L + Z_{TR}}$
	$I_L = 3,854 \angle 137.1^\circ A \times \frac{(4 + j20) \times 10^{10} \Omega}{(4 + j20) \Omega + (4 + j20) \times 10^{10} \Omega}$
	$I_L = 3,854 \angle 137.1^\circ A$
The voltage, as measured by the relay on $Z_L$ (Figure 3), is the voltage drop from the sending-end source through the sending-end source impedance.	
Eq. (52)	$V_S = E_S - (Z_S \times I_L)$
	$V_S = 132,791 \angle 240^\circ V - [(2 + j10) \Omega \times 3,854 \angle 137.1^\circ A]$
	$V_S = 98,265 \angle -110.6^\circ V$
The impedance seen by the relay on $Z_L$ .	
Eq. (53)	$Z_{L-Relay} = \frac{V_S}{I_L}$
	$Z_{L-Relay} = \frac{98,265 \angle -110.6^\circ V}{3,854 \angle 137.1^\circ A}$
	$Z_{L-Relay} = -9.676 + j23.59 \Omega$

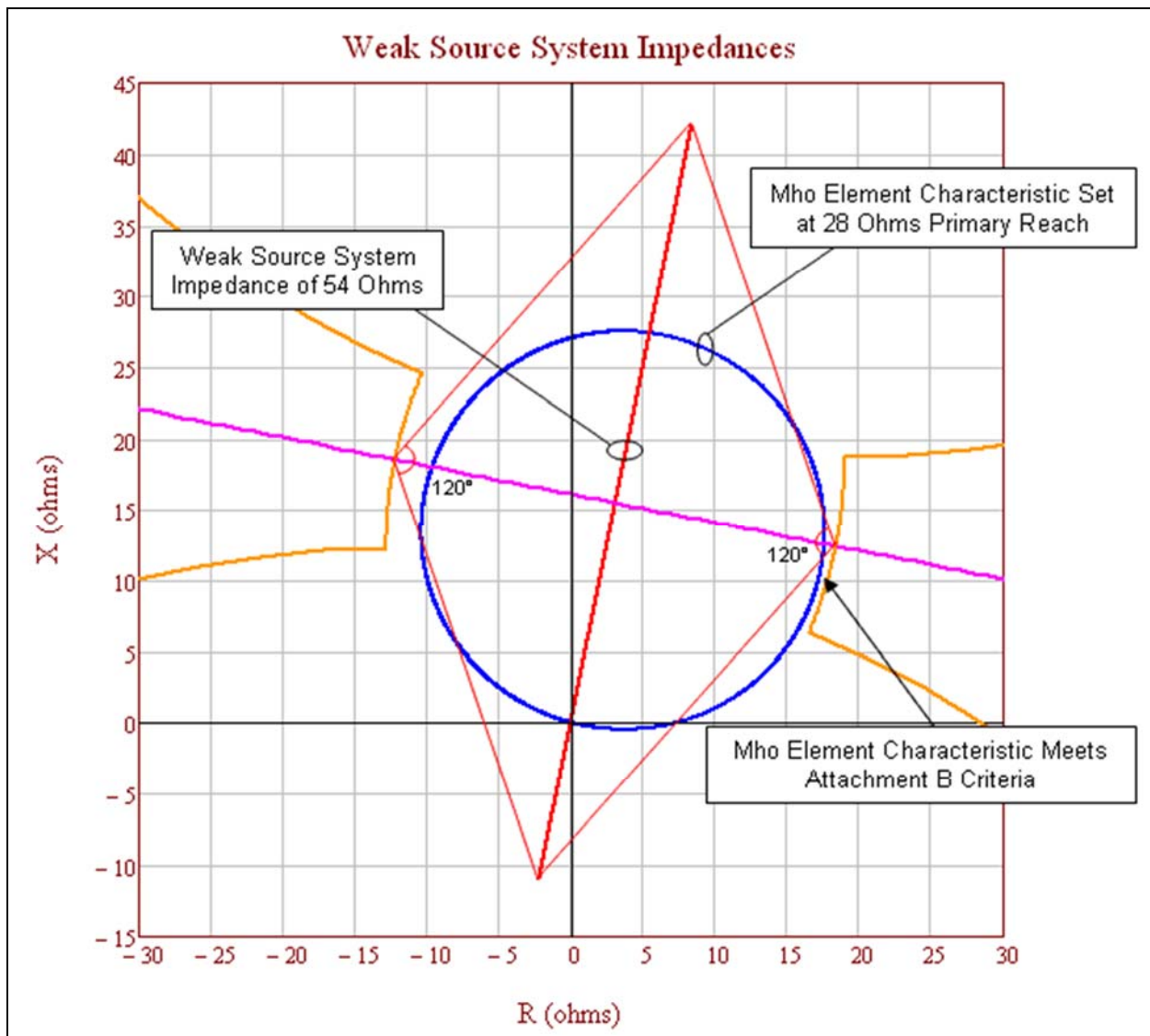






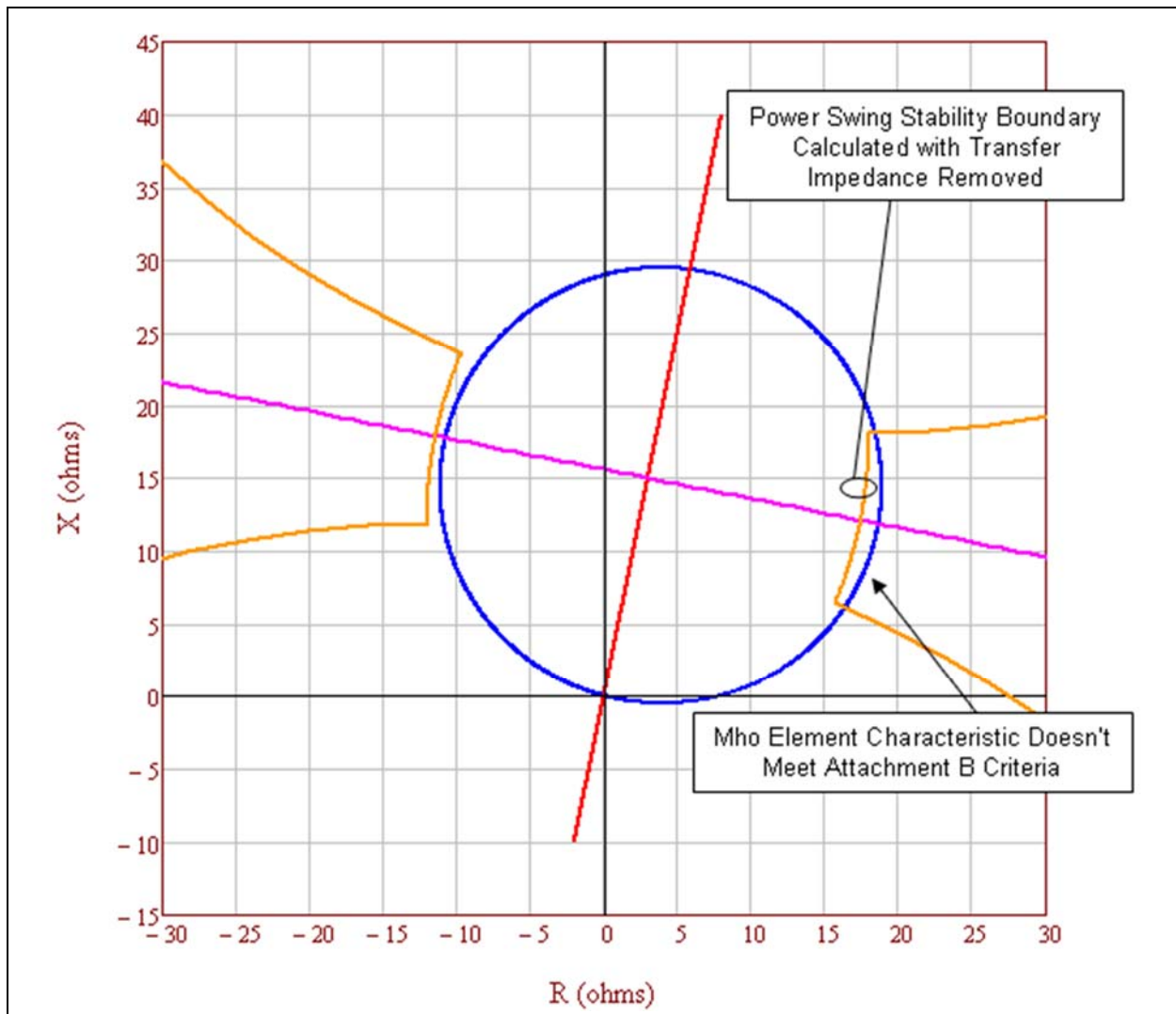
**Figure 8:** A strong-source system with a line impedance of  $Z_L = 20.4$  ohms (i.e., the thicker red line). This mho element characteristic (i.e., the blue circle) does not meet the PRC-026-1 – Attachment B, Criterion A because it is not completely contained within the unstable power swing region (i.e., the orange characteristic).

Figure 8 above represents a heavily-loaded system with all generation in service and all transmission BES Elements in their normal operating state. The mho element characteristic (set at 137% of  $Z_L$ ) extends into the unstable power swing region (i.e., the orange characteristic). Using the strongest source system is more conservative because it shrinks the unstable power swing region, bringing it closer to the mho element characteristic. This figure also graphically represents the effect of a system strengthening over time and this is the reason for re-evaluation if the relay has not been evaluated in the last five calendar years. Figure 9 below depicts a relay that meets the PRC-026-1 – Attachment B, Criterion A. Figure 8 depicts the same relay with the same setting five years later, where each source has strengthened by about 10% and now the same mho element characteristic does not meet Criterion A.



**Figure 9:** A weak-source system with a line impedance of  $Z_L = 20.4$  ohms (i.e., the thicker red line). This mho element characteristic (i.e., the blue circle) meets the PRC-026-1 – Attachment B, Criterion A because it is completely contained within the unstable power swing region (i.e., the orange characteristic).

Figure 9 above represents a lightly-loaded system, using a minimum generation profile. The mho element characteristic (set at 137% of  $Z_L$ ) does not extend into the unstable power swing region (i.e., the orange characteristic). Using a weaker source system expands the unstable power swing region away from the mho element characteristic.

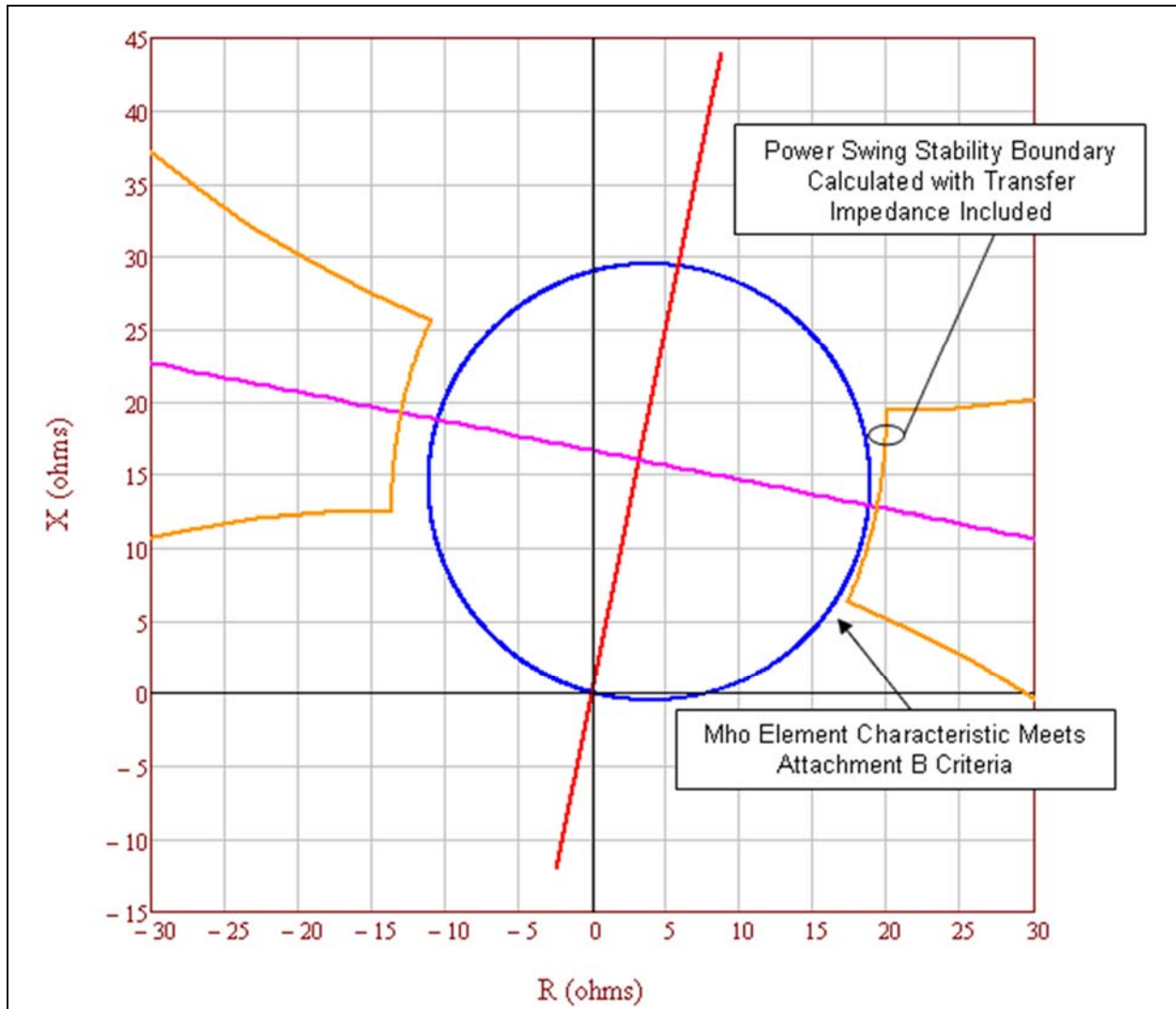


**Figure 10:** This is an example of an unstable power swing region (i.e., the orange characteristic) with the parallel transfer impedance removed. This relay mho element characteristic (i.e., the blue circle) does not meet PRC-026-1 – Attachment B, Criterion A because it is not completely contained within the unstable power swing region.

Table 8: Example Calculation (Parallel Transfer Impedance Removed)	
Calculations for the point at 120 degrees with equal source impedances. The total system current equals the line current. See Figure 10.	
Eq. (54)	$E_S = \frac{V_{LL} \angle 120^\circ}{\sqrt{3}}$
	$E_S = \frac{230,000 \angle 120^\circ V}{\sqrt{3}}$
	$E_S = 132,791 \angle 120^\circ V$

Table 8: Example Calculation (Parallel Transfer Impedance Removed)			
Eq. (55)	$E_R = \frac{V_{LL} \angle 0^\circ}{\sqrt{3}}$		
	$E_R = \frac{230,000 \angle 0^\circ V}{\sqrt{3}}$		
	$E_R = 132,791 \angle 0^\circ V$		
Given impedance data.			
Given:	$Z_S = 2 + j10 \Omega$	$Z_L = 4 + j20 \Omega$	$Z_R = 4 + j20 \Omega$
Given:	$Z_{TR} = Z_L \times 10^{10} \Omega$		
Total impedance between the generators.			
Eq. (56)	$Z_{total} = \frac{(Z_L \times Z_{TR})}{(Z_L + Z_{TR})}$		
	$Z_{total} = \frac{((4 + j20) \Omega \times (4 + j20) \times 10^{10} \Omega)}{((4 + j20) \Omega + (4 + j20) \times 10^{10} \Omega)}$		
	$Z_{total} = 4 + j20 \Omega$		
Total system impedance.			
Eq. (57)	$Z_{sys} = Z_S + Z_{total} + Z_R$		
	$Z_{sys} = (2 + j10) \Omega + (4 + j20) \Omega + (4 + j20) \Omega$		
	$Z_{sys} = 10 + j50 \Omega$		
Total system current from sending-end source.			
Eq. (58)	$I_{sys} = \frac{E_S - E_R}{Z_{sys}}$		
	$I_{sys} = \frac{132,791 \angle 120^\circ V - 132,791 \angle 0^\circ V}{10 + j50 \Omega}$		
	$I_{sys} = 4,511 \angle 71.3^\circ A$		
The current, as measured by the relay on $Z_L$ (Figure 3), is only the current flowing through that line as determined by using the current divider equation.			
Eq. (59)	$I_L = I_{sys} \times \frac{Z_{TR}}{Z_L + Z_{TR}}$		
	$I_L = 4,511 \angle 71.3^\circ A \times \frac{(4 + j20) \times 10^{10} \Omega}{(4 + j20) \Omega + (4 + j20) \times 10^{10} \Omega}$		
	$I_L = 4,511 \angle 71.3^\circ A$		

Table 8: Example Calculation (Parallel Transfer Impedance Removed)	
The voltage, as measured by the relay on $Z_L$ (Figure 3), is the voltage drop from the sending-end source through the sending-end source impedance.	
Eq. (60)	$V_S = E_S - (Z_S \times I_{sys})$
	$V_S = 132,791 \angle 120^\circ V - [(2 + j10 \Omega) \times 4,511 \angle 71.3^\circ A]$
	$V_S = 95,757 \angle 106.1^\circ V$
The impedance seen by the relay on $Z_L$ .	
Eq. (61)	$Z_{L-Relay} = \frac{V_S}{I_L}$
	$Z_{L-Relay} = \frac{95,757 \angle 106.1^\circ V}{4,511 \angle 71.3^\circ A}$
	$Z_{L-Relay} = 17.434 + j12.113 \Omega$



**Figure 11:** This is an example of an unstable power swing region (i.e., the orange characteristic) with the parallel transfer impedance included causing the mho element characteristic (i.e., the blue circle) to appear to meet the PRC-026-1 – Attachment B, Criterion A because it is completely contained within the unstable power swing region. Including the parallel transfer impedance in the calculation is not allowed by the PRC-026-1 – Attachment B, Criterion A.

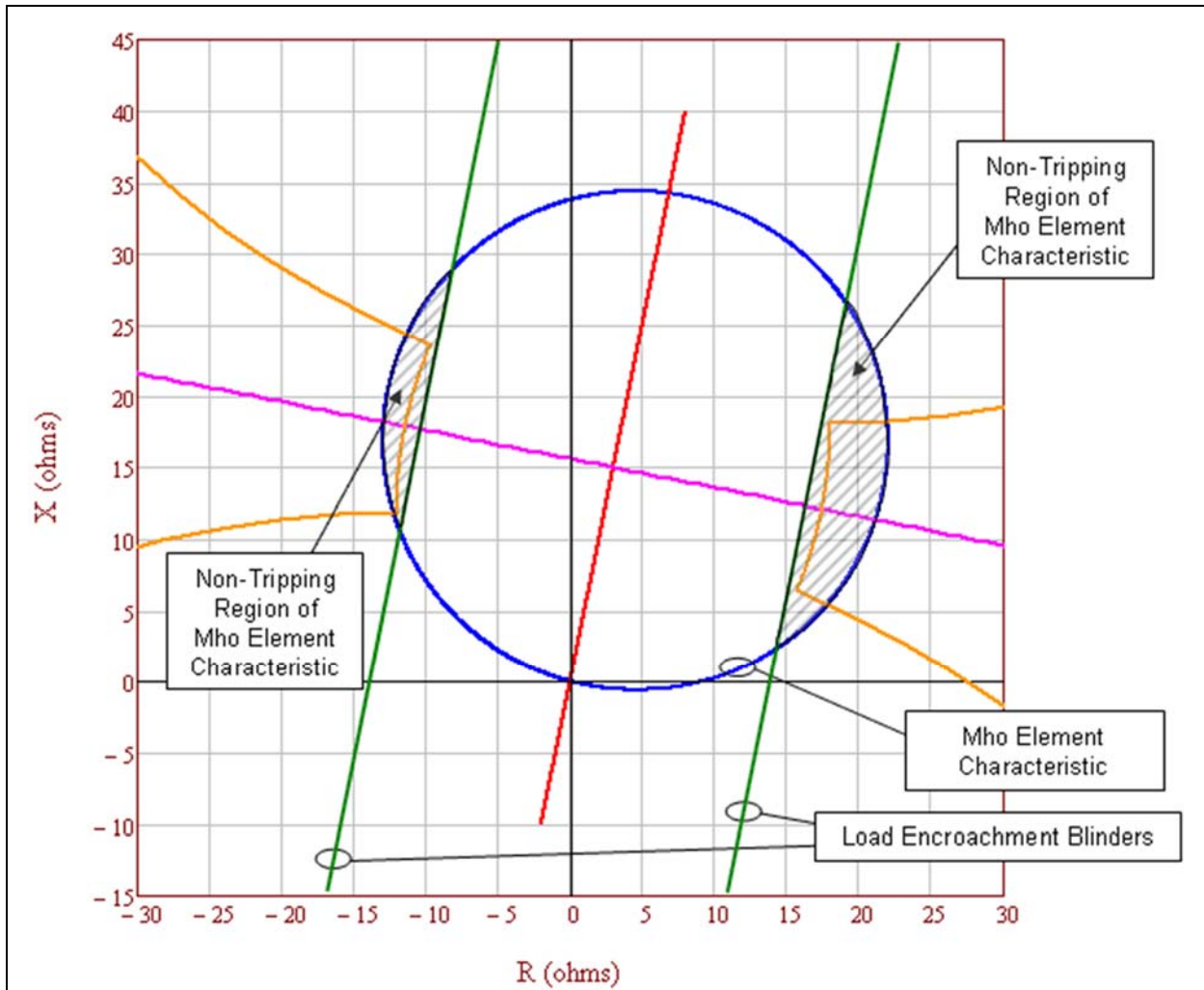
In Figure 11 above, the parallel transfer impedance is 5 times the line impedance. The unstable power swing region has expanded out beyond the mho element characteristic due to the infeed effect from the parallel current through the parallel transfer impedance, thus allowing the mho element characteristic to appear to meet the PRC-026-1 – Attachment B, Criterion A. Including the parallel transfer impedance in the calculation is not allowed by the PRC-026-1 – Attachment B, Criterion A.

Table 9: Example Calculation (Parallel Transfer Impedance Included)			
Calculations for the point at 120 degrees with equal source impedances. The total system current does not equal the line current. See Figure 11.			
Eq. (62)	$E_S = \frac{V_{LL} \angle 120^\circ}{\sqrt{3}}$		
	$E_S = \frac{230,000 \angle 120^\circ V}{\sqrt{3}}$		
	$E_S = 132,791 \angle 120^\circ V$		
Eq. (63)	$E_R = \frac{V_{LL} \angle 0^\circ}{\sqrt{3}}$		
	$E_R = \frac{230,000 \angle 0^\circ V}{\sqrt{3}}$		
	$E_R = 132,791 \angle 0^\circ V$		
Given impedance data.			
Given:	$Z_S = 2 + j10 \Omega$	$Z_L = 4 + j20 \Omega$	$Z_R = 4 + j20 \Omega$
Given:	$Z_{TR} = Z_L \times 5$		
	$Z_{TR} = (4 + j20) \Omega \times 5$		
	$Z_{TR} = 20 + j100 \Omega$		
Total impedance between the generators.			
Eq. (64)	$Z_{total} = \frac{(Z_L \times Z_{TR})}{(Z_L + Z_{TR})}$		
	$Z_{total} = \frac{(4 + j20) \Omega \times (20 + j100) \Omega}{(4 + j20) \Omega + (20 + j100) \Omega}$		
	$Z_{total} = 3.333 + j16.667 \Omega$		
Total system impedance.			
Eq. (65)	$Z_{sys} = Z_S + Z_{total} + Z_R$		
	$Z_{sys} = (2 + j10) \Omega + (3.333 + j16.667) \Omega + (4 + j20) \Omega$		
	$Z_{sys} = 9.333 + j46.667 \Omega$		
Total system current from sending-end source.			
Eq. (66)	$I_{sys} = \frac{E_S - E_R}{Z_{sys}}$		
	$I_{sys} = \frac{132,791 \angle 120^\circ V - 132,791 \angle 0^\circ V}{9.333 + j46.667 \Omega}$		

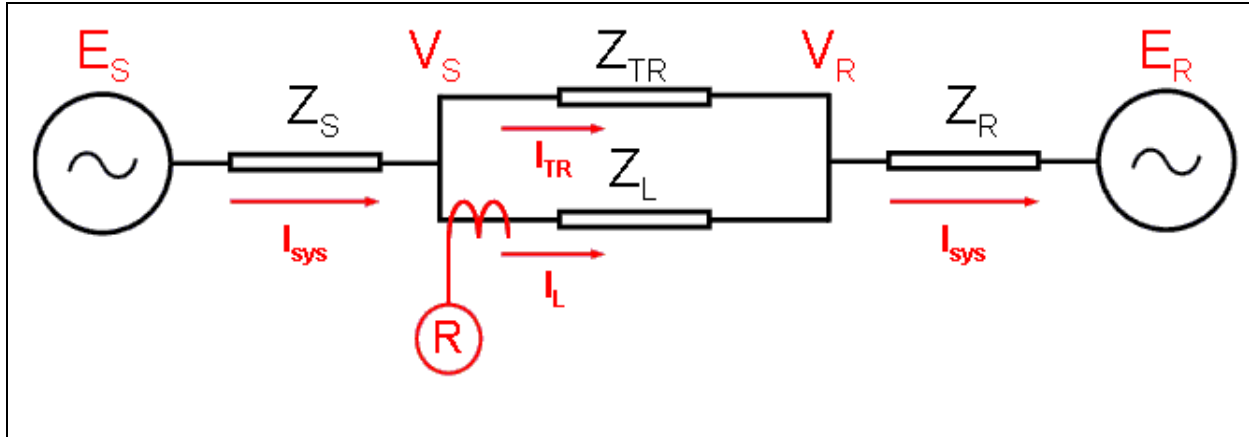
Table 9: Example Calculation (Parallel Transfer Impedance Included)	
	$I_{sys} = 4,833 \angle 71.3^\circ A$
The current, as measured by the relay on $Z_L$ (Figure 3), is only the current flowing through that line as determined by using the current divider equation.	
Eq. (67)	$I_L = I_{sys} \times \frac{Z_{TR}}{Z_L + Z_{TR}}$
	$I_L = 4,833 \angle 71.3^\circ A \times \frac{(20 + j100) \Omega}{(4 + j20) \Omega + (20 + j100) \Omega}$
	$I_L = 4,027.4 \angle 71.3^\circ A$
The voltage, as measured by the relay on $Z_L$ (Figure 3), is the voltage drop from the sending-end source through the sending-end source impedance.	
Eq. (68)	$V_S = E_S - (Z_S \times I_{sys})$
	$V_S = 132,791 \angle 120^\circ V - [(2 + j10 \Omega) \times 4,833 \angle 71.3^\circ A]$
	$V_S = 93,417 \angle 104.7^\circ V$
The impedance seen by the relay on $Z_L$ .	
Eq. (69)	$Z_{L-Relay} = \frac{V_S}{I_L}$
	$Z_{L-Relay} = \frac{93,417 \angle 104.7^\circ V}{4,027 \angle 71.3^\circ A}$
	$Z_{L-Relay} = 19.366 + j12.767 \Omega$



<b>Table 10: Percent Increase of a Lens Due To Parallel Transfer Impedance.</b>	
The following demonstrates the percent size increase of the lens characteristic for $Z_{TR}$ in multiples of $Z_L$ with the parallel transfer impedance included.	
$Z_{TR}$ in multiples of $Z_L$	Percent increase of lens with equal EMF sources (Infinite source as reference)
Infinite	N/A
1000	0.05%
100	0.46%
10	4.63%
5	9.27%
2	23.26%
1	46.76%
0.5	94.14%
0.25	189.56%



**Figure 12:** The tripping portion of the mho element characteristic (i.e., the blue circle) not blocked by load encroachment (i.e., the parallel green lines) is completely contained within the unstable power swing region (i.e., the orange characteristic). Therefore, the mho element characteristic meets the PRC-026-1 – Attachment B, Criterion A.



**Figure 13:** The infeed diagram shows the impedance in front of the relay R with the parallel transfer impedance included. As the parallel transfer impedance approaches infinity, the impedances seen by the relay R in the forward direction becomes  $Z_L + Z_R$ .

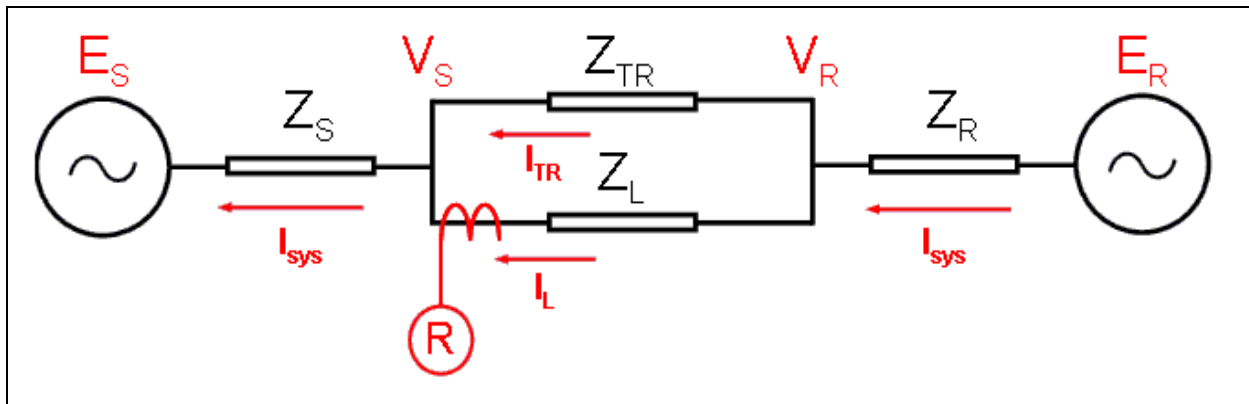
**Table 11: Calculations (System Apparent Impedance in the forward direction)**

The following equations are provided for calculating the apparent impedance back to the  $E_R$  source voltage as seen by relay R. Infeed equations from  $V_S$  to source  $E_R$  where  $E_R = 0$ . See Figure 13.

Eq. (70)	$I_L = \frac{V_S - V_R}{Z_L}$			
Eq. (71)	$I_{sys} = \frac{V_R - E_R}{Z_R}$			
Eq. (72)	$I_{sys} = I_L + I_{TR}$			
Eq. (73)	$I_{sys} = \frac{V_R}{Z_R}$	Since $E_R = 0$	Rearranged:	$V_R = I_{sys} \times Z_R$
Eq. (74)	$I_L = \frac{V_S - I_{sys} \times Z_R}{Z_L}$			
Eq. (75)	$I_L = \frac{V_S - [(I_L + I_{TR}) \times Z_R]}{Z_L}$			
Eq. (76)	$V_S = (I_L \times Z_L) + (I_L \times Z_R) + (I_{TR} \times Z_R)$			
Eq. (77)	$Z_{Relay} = \frac{V_S}{I_L} = Z_L + Z_R + \frac{I_{TR} \times Z_R}{I_L} = Z_L + Z_R \times \left(1 + \frac{I_{TR}}{I_L}\right)$			
Eq. (78)	$I_{TR} = I_{sys} \times \frac{Z_L}{Z_L + Z_{TR}}$			
Eq. (79)	$I_L = I_{sys} \times \frac{Z_{TR}}{Z_L + Z_{TR}}$			

**Table 11: Calculations (System Apparent Impedance in the forward direction)**

Eq. (80)	$\frac{I_{TR}}{I_L} = \frac{Z_L}{Z_{TR}}$
The infeed equations shows the impedance in front of the relay R (Figure 13) with the parallel transfer impedance included. As the parallel transfer impedance approaches infinity, the impedances seen by the relay R in the forward direction becomes $Z_L + Z_R$ .	
Eq. (81)	$Z_{Relay} = Z_L + Z_R \times \left(1 + \frac{Z_L}{Z_{TR}}\right)$

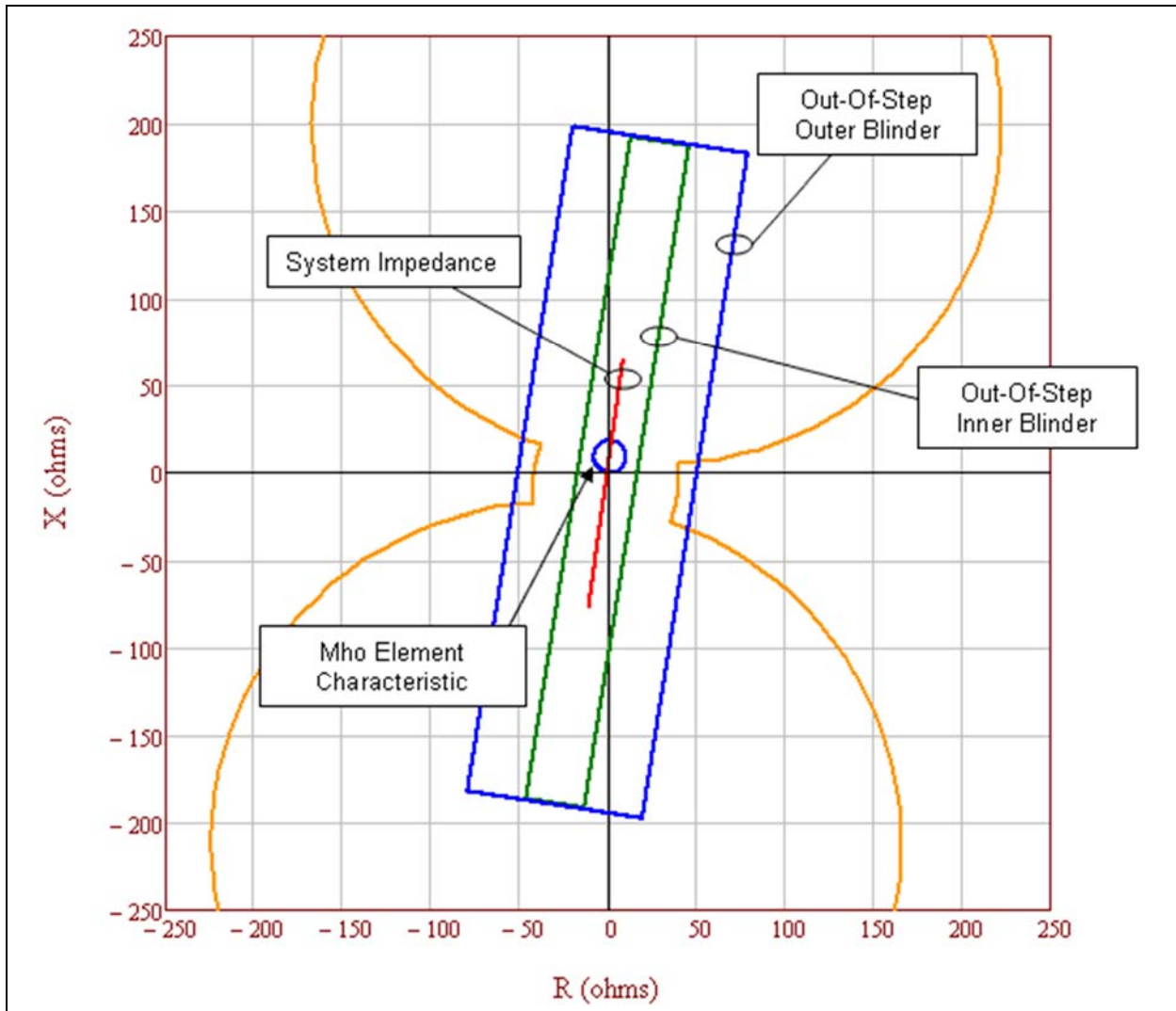


**Figure 14:** The infeed diagram shows the impedance behind relay R with the parallel transfer impedance included. As the parallel transfer impedance approaches infinity, the impedances seen by the relay R in the reverse direction becomes  $Z_S$ .

**Table 12: Calculations (System Apparent Impedance in the Reverse Direction)**

The following equations are provided for calculating the apparent impedance back to the $E_S$ source voltage as seen by relay R. Infeed equations from $V_R$ back to source $E_S$ where $E_S = 0$ . See Figure 14.				
Eq. (82)	$I_L = \frac{V_R - V_S}{Z_L}$			
Eq. (83)	$I_{sys} = \frac{V_S - E_S}{Z_S}$			
Eq. (84)	$I_{sys} = I_L + I_{TR}$			
Eq. (85)	$I_{sys} = \frac{V_S}{Z_S}$	Since $E_S = 0$	Rearranged:	$V_S = I_{sys} \times Z_S$
Eq. (86)	$I_L = \frac{V_R - I_{sys} \times Z_S}{Z_L}$			

Table 12: Calculations (System Apparent Impedance in the Reverse Direction)		
Eq. (87)	$I_L = \frac{V_R - [(I_L + I_{TR}) \times Z_S]}{Z_L}$	
Eq. (88)	$V_R = (I_L \times Z_L) + (I_L \times Z_S) + (I_{TR} \times Z_{RS})$	
Eq. (89)	$Z_{Relay} = \frac{V_R}{I_L} = Z_L + Z_S + \frac{I_{TR} \times Z_S}{I_L} = Z_L + Z_S \times \left(1 + \frac{I_{TR}}{I_L}\right)$	
Eq. (90)	$I_{TR} = I_{sys} \times \frac{Z_L}{Z_L + Z_{TR}}$	
Eq. (91)	$I_L = I_{sys} \times \frac{Z_{TR}}{Z_L + Z_{TR}}$	
Eq. (92)	$\frac{I_{TR}}{I_L} = \frac{Z_L}{Z_{TR}}$	
The infeed equations shows the impedance behind relay R (Figure 14) with the parallel transfer impedance included. As the parallel transfer impedance approaches infinity, the impedances seen by the relay R in the reverse direction becomes $Z_S$ .		
Eq. (93)	$Z_{Relay} = Z_L + Z_S \times \left(1 + \frac{Z_L}{Z_{TR}}\right)$	As seen by relay R at the receiving-end of the line.
Eq. (94)	$Z_{Relay} = Z_S \times \left(1 + \frac{Z_L}{Z_{TR}}\right)$	Subtract $Z_L$ for relay R impedance as seen at sending-end of the line.



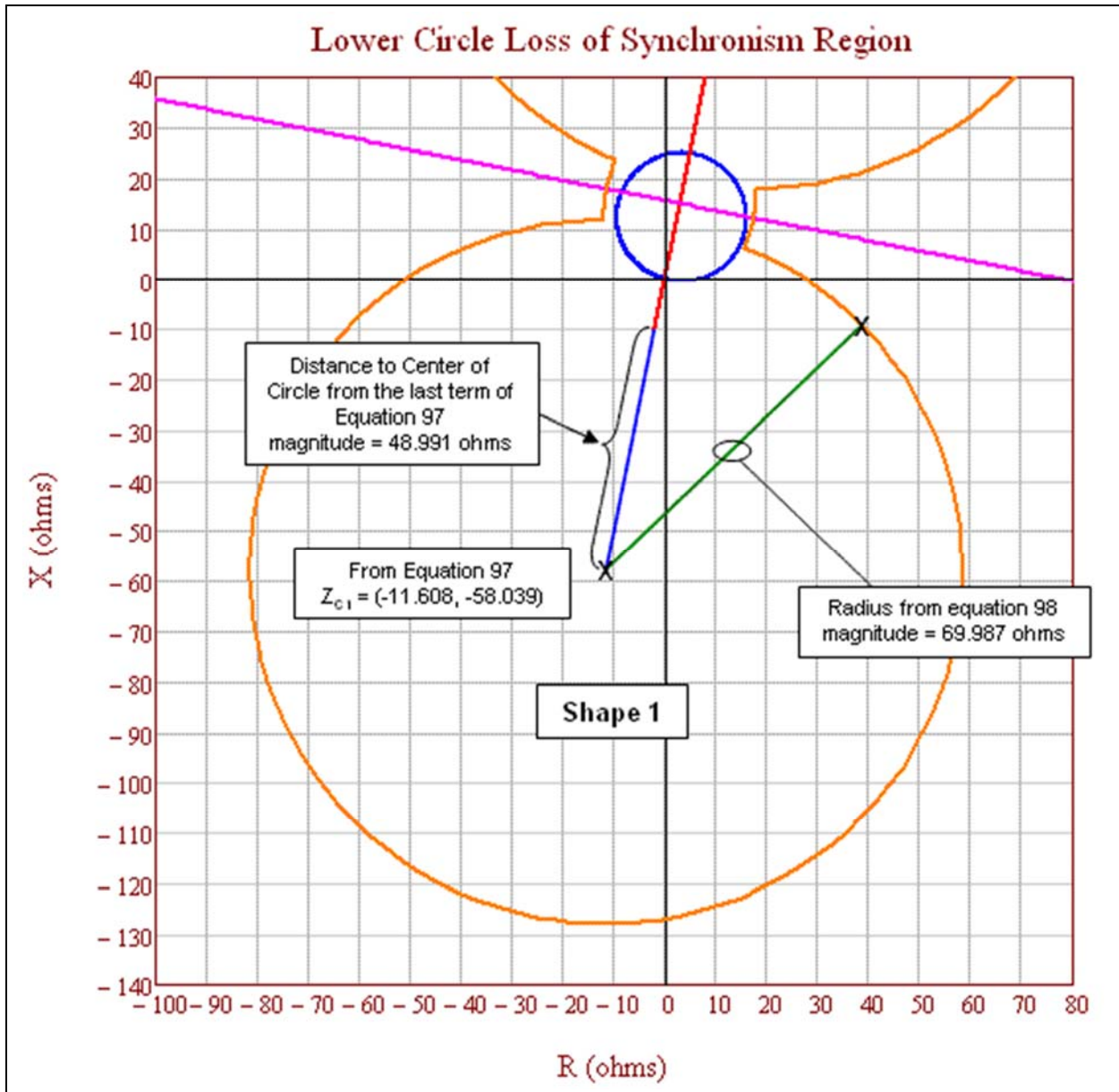
**Figure 15:** Out-of-step trip (OST) inner blinder (i.e., the parallel green lines) meets the PRC-026-1 – Attachment B, Criterion A because the inner OST blinder initiates tripping either On-The-Way-In or On-The-Way-Out. Since the inner blinder is completely contained within the unstable power swing region (i.e., the orange characteristic), it meets the PRC-026-1 – Attachment B, Criterion A.

<b>Table 13: Example Calculation (Voltage Ratios)</b>			
These calculations are based on the loss-of-synchronism characteristics for the cases of $N < 1$ and $N > 1$ as found in the <i>Application of Out-of-Step Blocking and Tripping Relays</i> , GER-3180, p. 12, Figure 3. <sup>18</sup> The GE illustration shows the formulae used to calculate the radius and center of the circles that make up the ends of the portion of the lens.			
Voltage ratio equations, source impedance equation with infeed formulae applied, and circle equations.			
Given:	$E_S = 0.7$	$E_R = 1.0$	
Eq. (95)	$N = \frac{ E_S }{ E_R } = \frac{0.7}{1.0} = 0.7$		
The total system impedance as seen by the relay with infeed formulae applied.			
Given:	$Z_S = 2 + j10 \Omega$	$Z_L = 4 + j20 \Omega$	$Z_R = 4 + j20 \Omega$
Given:	$Z_{TR} = Z_L \times 10^{10} \Omega$		
	$Z_{TR} = (4 + j20) \times 10^{10} \Omega$		
Eq. (96)	$Z_{sys} = Z_S \times \left(1 + \frac{Z_L}{Z_{TR}}\right) + \left[Z_L + Z_R \times \left(1 + \frac{Z_L}{Z_{TR}}\right)\right]$		
	$Z_{sys} = 10 + j50 \Omega$		
The calculated coordinates of the lower loss-of-synchronism circle center.			
Eq. (97)	$Z_{C1} = - \left[ Z_S \times \left(1 + \frac{Z_L}{Z_{TR}}\right) \right] - \left[ \frac{N^2 \times Z_{sys}}{1 - N^2} \right]$		
	$Z_{C1} = - \left[ (2 + j10) \Omega \times \left(1 + \frac{(4 + j20) \Omega}{(4 + j20) \times 10^{10} \Omega}\right) \right] - \left[ \frac{0.7^2 \times (10 + j50) \Omega}{1 - 0.7^2} \right]$		
	$Z_{C1} = -11.608 - j58.039 \Omega$		
The calculated radius of the lower loss-of-synchronism circle.			
Eq. (98)	$r_a = \left  \frac{N \times Z_{sys}}{1 - N^2} \right $		
	$r_a = \left  \frac{0.7 \times (10 + j50) \Omega}{1 - 0.7^2} \right $		
	$r_a = 69.987 \Omega$		
The calculated coordinates of the upper loss-of-synchronism circle center.			
Given:	$E_S = 1.0$	$E_R = 0.7$	

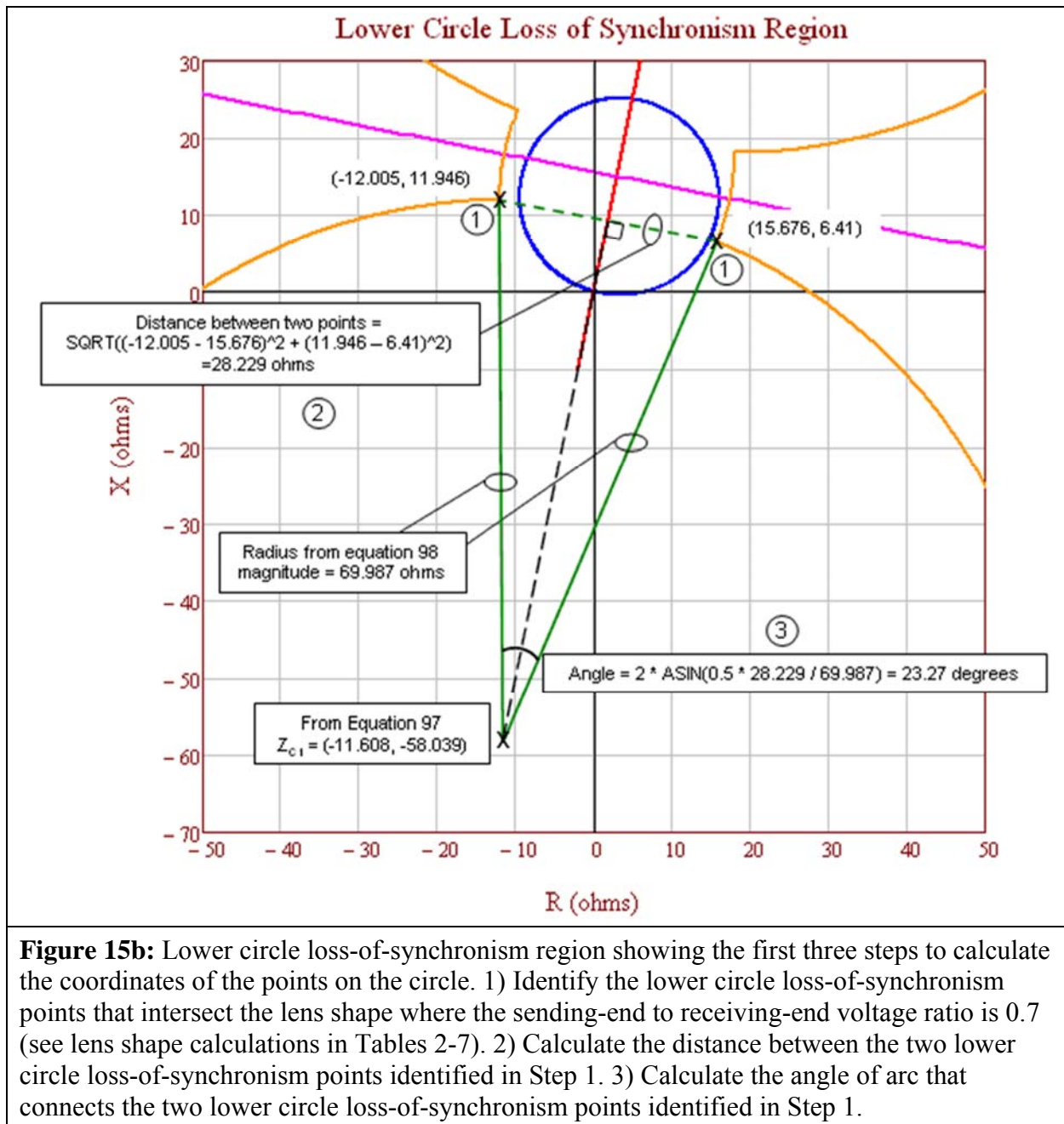
<sup>18</sup> <http://store.gedigitalenergy.com/faq/Documents/Alps/GER-3180.pdf>

Table 13: Example Calculation (Voltage Ratios)	
Eq. (99)	$N = \frac{ E_S }{ E_R } = \frac{1.0}{0.7} = 1.43$
Eq. (100)	$Z_{C2} = Z_L + \left[ Z_R \times \left( 1 + \frac{Z_L}{Z_{TR}} \right) \right] + \left[ \frac{Z_{sys}}{N^2 - 1} \right]$
	$Z_{C2} = 4 + j20 \Omega + \left[ (4 + j20) \Omega \times \left( 1 + \frac{(4 + j20) \Omega}{(4 + j20) \times 10^{10} \Omega} \right) \right] + \left[ \frac{(10 + j50) \Omega}{1.43^2 - 1} \right]$
	$Z_{C2} = 17.608 + j88.039 \Omega$
The calculated radius of the upper loss-of-synchronism circle.	
Eq. (101)	$r_b = \left  \frac{N \times Z_{sys}}{N^2 - 1} \right $
	$r_b = \left  \frac{1.43 \times (10 + j50) \Omega}{1.43^2 - 1} \right $
	$r_b = 69.987 \Omega$

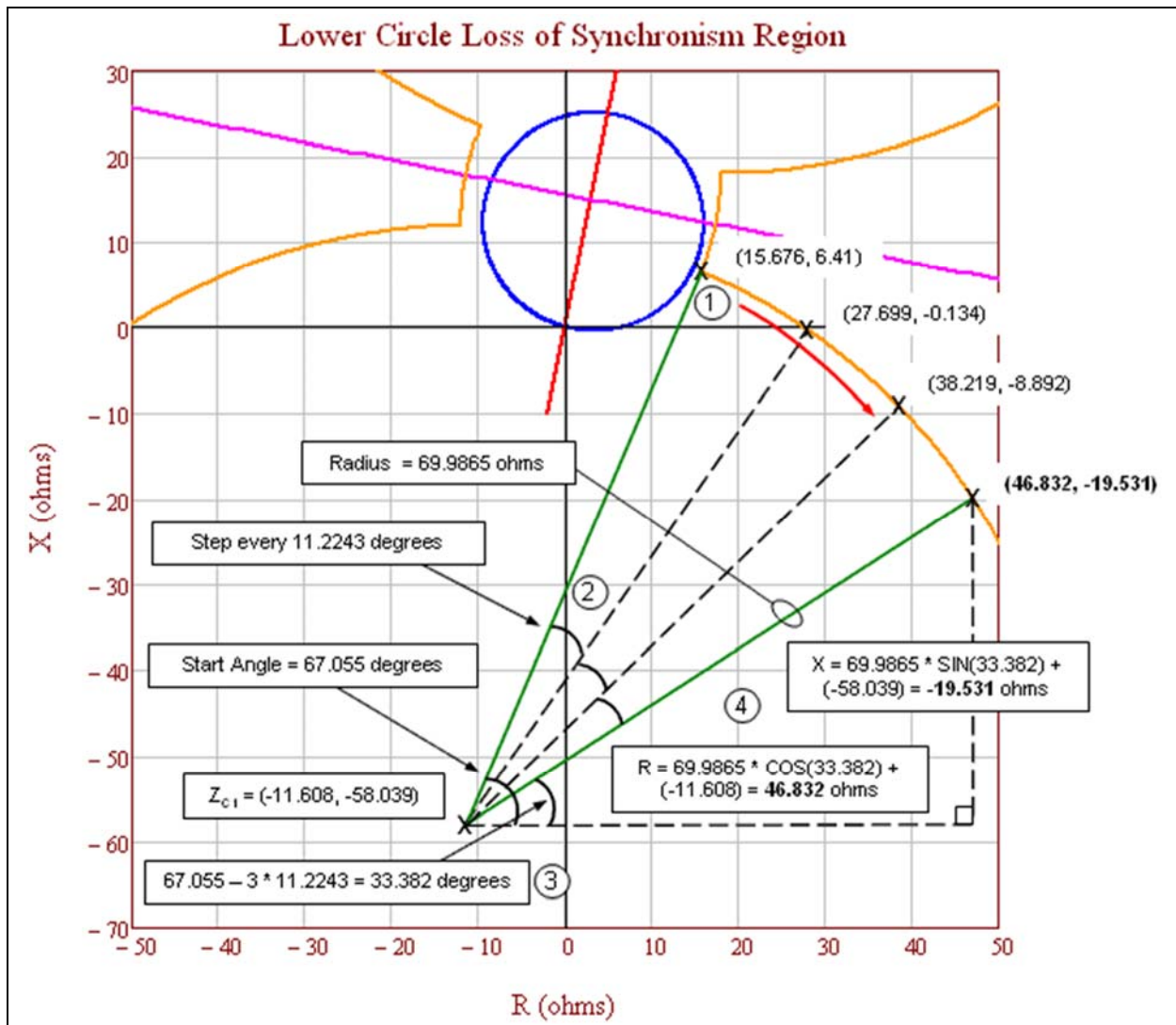




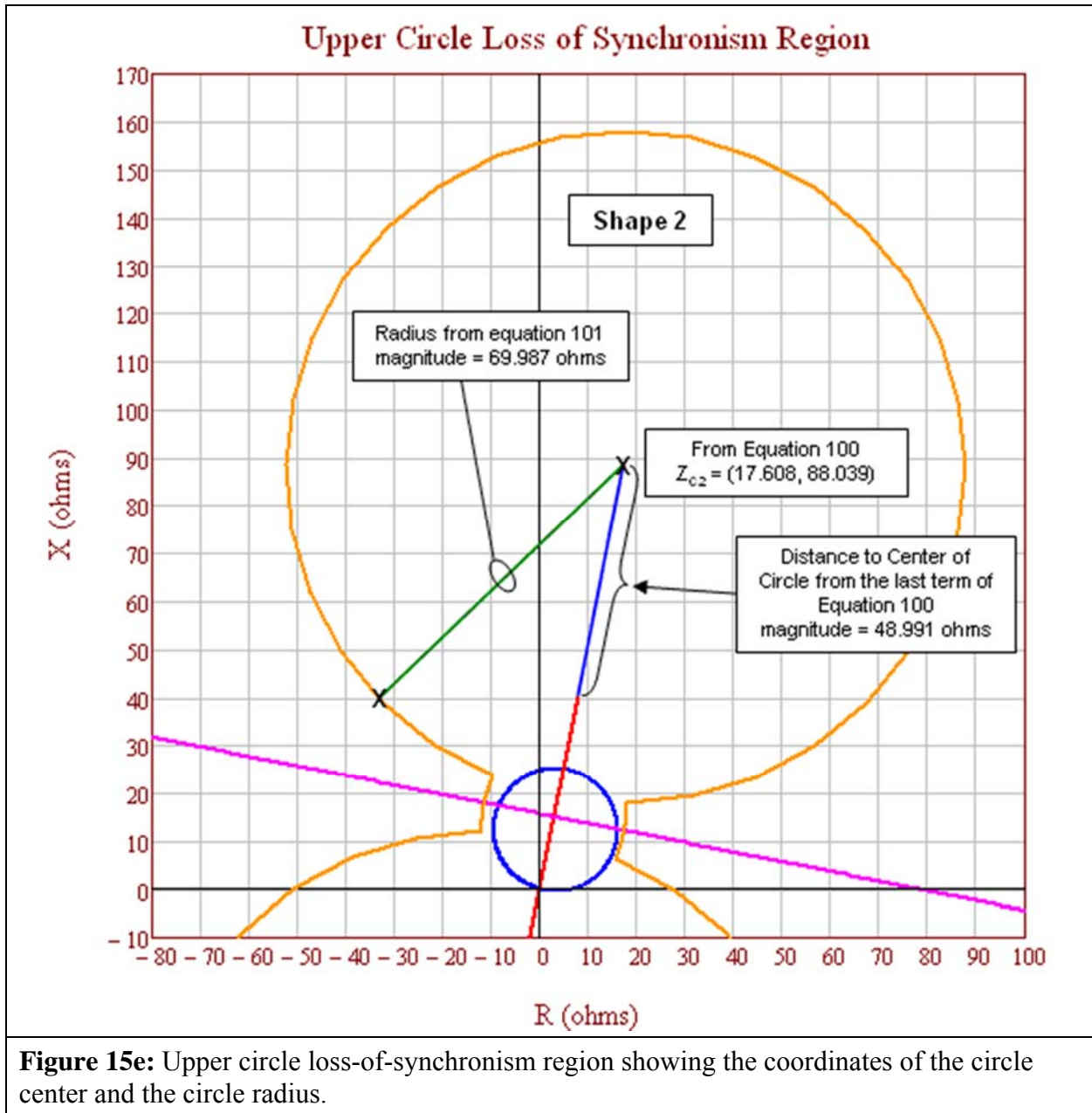
**Figure 15a:** Lower circle loss-of-synchronism region showing the coordinates of the circle center and the circle radius.

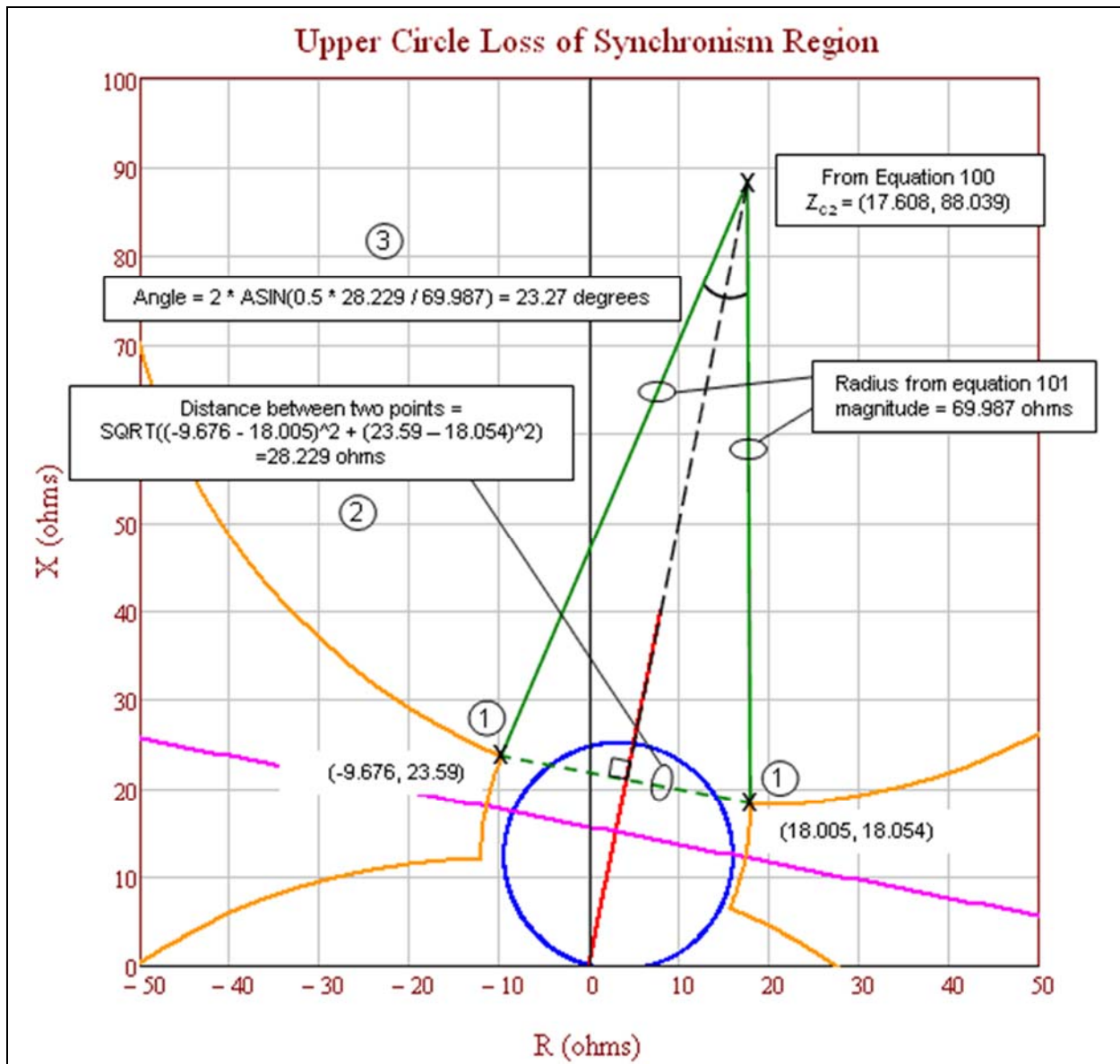




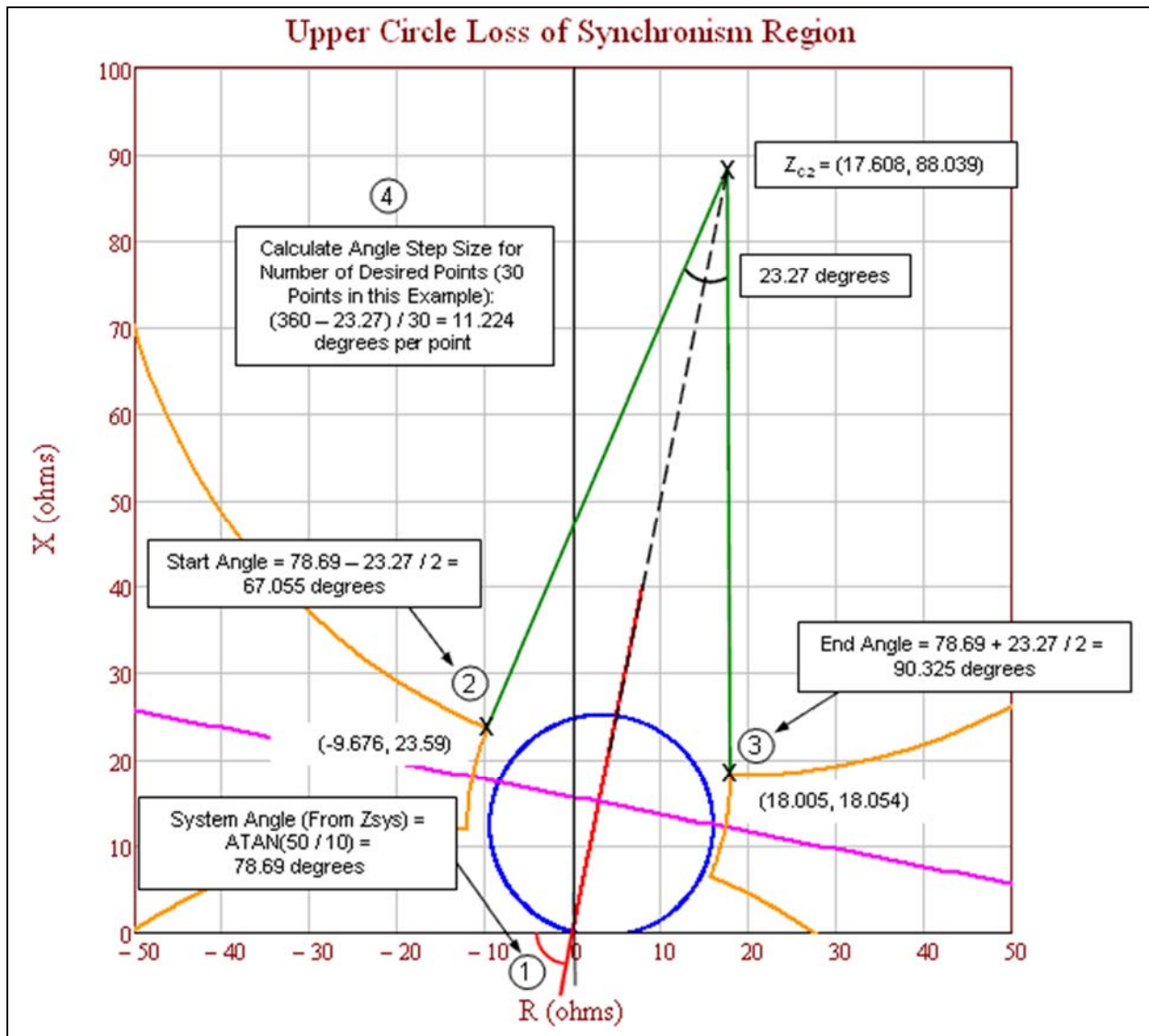


**Figure 15d:** Lower circle loss-of-synchronism region showing the final steps to calculate the coordinates of the points on the circle. 1) Start at the intersection with the lens shape and proceed in a clockwise direction. 2) Advance the step angle for each point. 3) Calculate the new angle after step advancement. 4) Calculate the R–X coordinates.

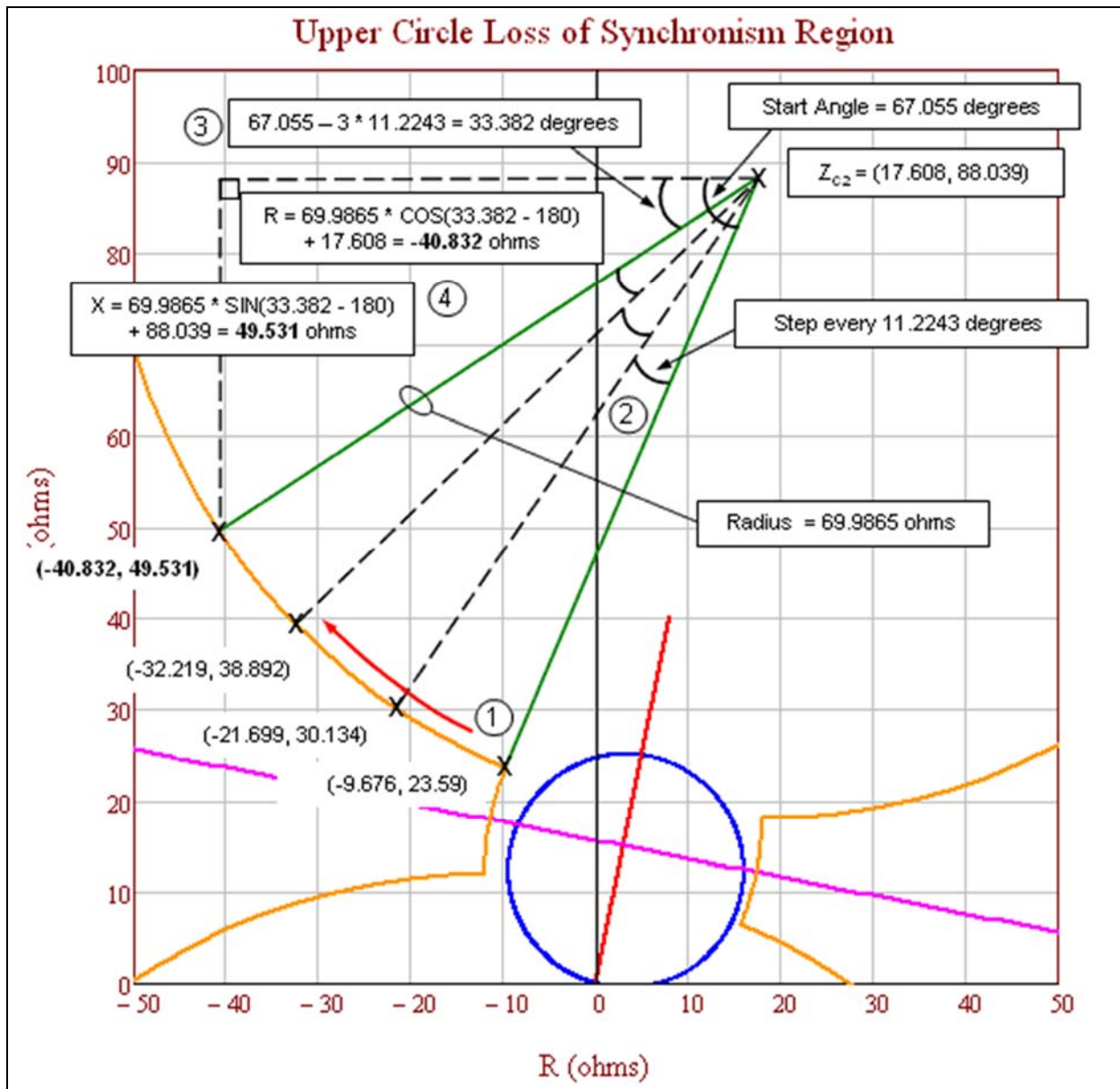




**Figure 15f:** Upper circle loss-of-synchronism region showing the first three steps to calculate the coordinates of the points on the circle. 1) Identify the upper circle points that intersect the lens shape where the sending-end to receiving-end voltage ratio is 1.43 (see lens shape calculations in Tables 2-7). 2) Calculate the distance between the two upper circle points identified in Step 1. 3) Calculate the angle of arc that connects the two upper circle points identified in Step 1.



**Figure 15g:** Upper circle loss-of-synchronism region showing the steps to calculate the start angle, end angle, and the angle step size for the desired number of calculated points. 1) Calculate the system angle. 2) Calculate the start angle. 3) Calculate the end angle. 4) Calculate the angle step size for the desired number of points.



**Figure 15h:** Upper circle loss-of-synchronism region showing the final steps to calculate the coordinates of the points on the circle. 1) Start at the intersection with the lens shape and proceed in a clockwise direction. 2) Advance the step angle for each point. 3) Calculate the new angle after step advancement. 4) Calculate the R-X coordinates.



Lower Loss of Synchronism Circle Coordinates			Upper Loss of Synchronism Circle Coordinates		
Angle (degrees)	R	+ jX	Angle (degrees)	R	+ jX
67.055	15.676	6.41	67.055	-9.676	23.59
55.831	27.699	-0.134	55.831	-21.699	30.134
44.606	38.219	-8.892	44.606	-32.219	38.892
<b>33.382</b>	<b>46.832</b>	<b>-19.531</b>	<b>33.382</b>	<b>-40.832</b>	<b>49.531</b>
22.158	53.21	-31.643	22.158	-47.21	61.643
10.933	57.108	-44.765	10.933	-51.108	74.765
359.709	58.378	-58.395	359.709	-52.378	88.395
348.485	56.97	-72.011	348.485	-50.97	102.011
337.26	52.939	-85.092	337.26	-46.939	115.092
326.036	46.438	-97.139	326.036	-40.438	127.139
314.812	37.717	-107.69	314.812	-31.717	137.69
303.587	27.109	-116.341	303.587	-21.109	146.341
292.363	15.02	-122.762	292.363	-9.02	152.762
281.139	1.913	-126.707	281.139	4.087	156.707
269.914	-11.712	-128.026	269.914	17.712	158.026
258.69	-25.333	-126.667	258.69	31.333	156.667
247.466	-38.429	-122.682	247.466	44.429	152.682
236.241	-50.499	-116.225	236.241	56.499	146.225
225.017	-61.081	-107.542	225.017	67.081	137.542
213.793	-69.771	-96.965	213.793	75.771	126.965
202.568	-76.235	-84.899	202.568	82.235	114.899
191.344	-80.227	-71.806	191.344	86.227	101.806
180.12	-81.594	-58.185	180.12	87.594	88.185
168.895	-80.284	-44.56	168.895	86.284	74.56
157.671	-76.347	-31.45	157.671	82.347	61.45
146.447	-69.933	-19.357	146.447	75.933	49.357
135.222	-61.288	-8.744	135.222	67.288	38.744
123.998	-50.742	-0.016	123.998	56.742	30.016
112.774	-38.699	6.491	112.774	44.699	23.509
101.549	-25.62	10.53	101.549	31.62	19.47
90.325	-12.005	11.946	90.325	18.005	18.054

**Figure 15i:** Full tables of calculated lower and upper loss-of-synchronism circle coordinates. The highlighted row is the detailed calculated points in Figures 15d and 15h.

### Application Specific to Criterion B

The PRC-026-1 – Attachment B, Criterion B evaluates overcurrent elements used for tripping. The same criteria as PRC-026-1 – Attachment B, Criterion A is used except for an additional criterion (No. 4) that calculates a current magnitude based upon generator internal voltage of 1.05 per unit. A value of 1.05 per unit generator voltage is used to establish a minimum pickup current value for overcurrent relays that have a time delay less than 15 cycles. The sending-end and receiving-end voltages are established at 1.05 per unit at 120 degree system separation angle. The 1.05 per unit is the typical upper end of the operating voltage, which is also consistent with the maximum power

## PRC-026-1 – Application Guidelines

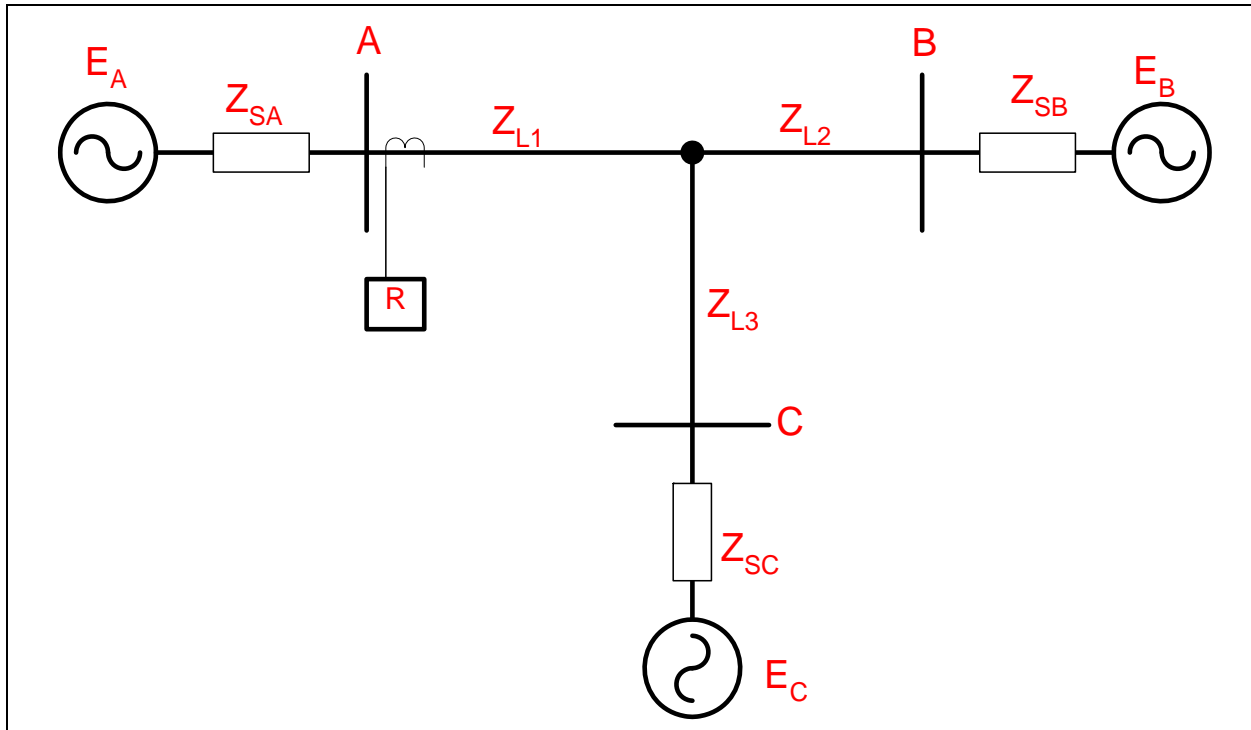
transfer calculation using actual system source impedances in the PRC-023 NERC Reliability Standard. The formulas used to calculate the current are in Table 14 below.

Table 14: Example Calculation (Overcurrent)			
<p>This example is for a 230 kV line terminal with a directional instantaneous phase overcurrent element set to 50 amps secondary times a CT ratio of 160:1 that equals 8,000 amps, primary. The following calculation is where <math>V_S</math> equals the base line-to-ground sending-end generator source voltage times 1.05 at an angle of 120 degrees, <math>V_R</math> equals the base line-to-ground receiving-end generator internal voltage times 1.05 at an angle of 0 degrees, and <math>Z_{sys}</math> equals the sum of the sending-end source, line, and receiving-end source impedances in ohms.</p> <p>Here, the instantaneous phase setting of 8,000 amps is greater than the calculated system current of 5,716 amps; therefore, it meets PRC-026-1 – Attachment B, Criterion B.</p>			
Eq. (102)	$V_S = \frac{V_{LL} \angle 120^\circ}{\sqrt{3}} \times 1.05$		
	$V_S = \frac{230,000 \angle 120^\circ V}{\sqrt{3}} \times 1.05$		
	$V_S = 139,430 \angle 120^\circ V$		
Receiving-end generator terminal voltage.			
Eq. (103)	$V_R = \frac{V_{LL} \angle 0^\circ}{\sqrt{3}} \times 1.05$		
	$V_R = \frac{230,000 \angle 0^\circ V}{\sqrt{3}} \times 1.05$		
	$V_R = 139,430 \angle 0^\circ V$		
<p>The total impedance of the system (<math>Z_{sys}</math>) equals the sum of the sending-end source impedance (<math>Z_S</math>), the impedance of the line (<math>Z_L</math>), and receiving-end impedance (<math>Z_R</math>) in ohms.</p>			
Given:	$Z_S = 3 + j26 \Omega$	$Z_L = 1.3 + j8.7 \Omega$	$Z_R = 0.3 + j7.3 \Omega$
Eq. (104)	$Z_{sys} = Z_S + Z_L + Z_R$		
	$Z_{sys} = (3 + j26) \Omega + (1.3 + j8.7) \Omega + (0.3 + j7.3) \Omega$		
	$Z_{sys} = 4.6 + j42 \Omega$		
Total system current.			
Eq. (105)	$I_{sys} = \frac{(V_S - V_R)}{Z_{sys}}$		
	$I_{sys} = \frac{(139,430 \angle 120^\circ V - 139,430 \angle 0^\circ V)}{(4.6 + j42) \Omega}$		
	$I_{sys} = 5,715.82 \angle 66.25^\circ A$		

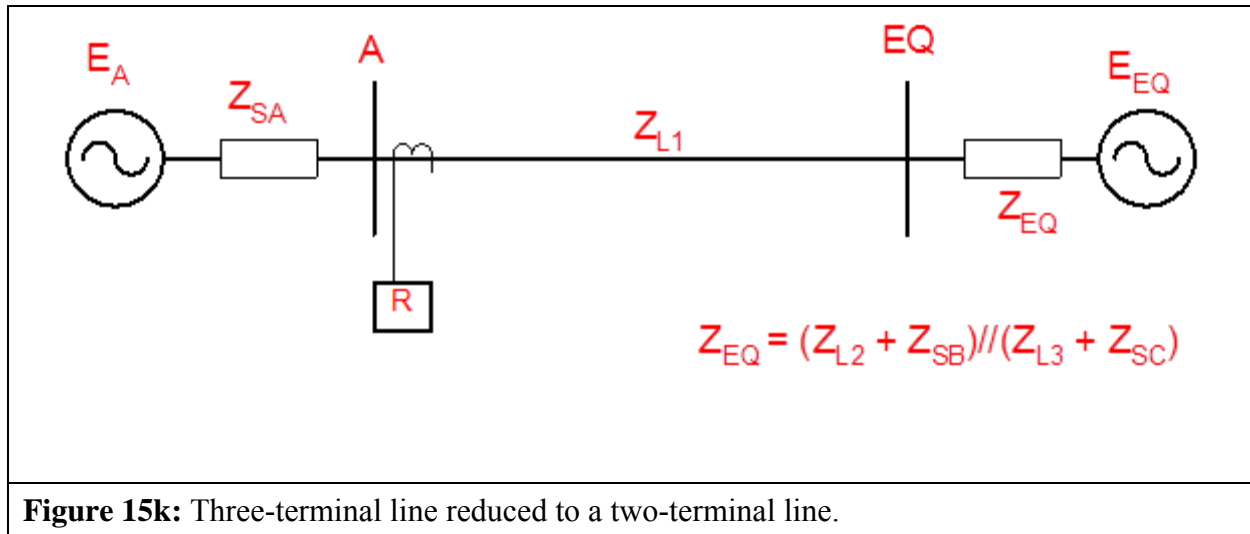
### Application Specific to Three-Terminal Lines

If a three-terminal line is identified as an Element that is susceptible to a power swing based on Requirement R1, the load-responsive protective relays at each end of the three-terminal line must be evaluated.

As shown in Figure 15j, the source impedances at each end of the line can be obtained from the similar short circuit calculation as for the two-terminal line (assuming the parallel transfer impedances are ignored).



**Figure 15j:** Three-terminal line. To evaluate the load-responsive protective relays on the three-terminal line at Terminal A, the circuit in Figure 15j is first reduced to the equivalent circuit shown in Figure 15k. The evaluation process for the load-responsive protective relays on the line at Terminal A will now be the same as that of the two-terminal line.



**Figure 15k:** Three-terminal line reduced to a two-terminal line.

### Application to Generation Elements

As with transmission BES Elements, the determination of the apparent impedance seen at an Element located at, or near, a generation Facility is complex for power swings due to various interdependent quantities. These variances in quantities are caused by changes in machine internal voltage, speed governor action, voltage regulator action, the reaction of other local generators, and the reaction of other interconnected transmission BES Elements as the event progresses through the time domain. Though transient stability simulations may be used to determine the apparent impedance for verifying load-responsive relay settings,<sup>19,20</sup> Requirement R2, PRC-026-1 – Attachment B, Criteria A and B provides a simplified method for evaluating the load-responsive protective relay’s susceptibility to tripping in response to a stable power swing without requiring stability simulations.

In general, the electrical center will be in the transmission system for cases where the generator is connected through a weak transmission system (high external impedance). In other cases where the generator is connected through a strong transmission system, the electrical center could be inside the unit connected zone.<sup>21</sup> In either case, load-responsive protective relays connected at the generator terminals or at the high-voltage side of the generator step-up (GSU) transformer may be challenged by power swings. Relays that may be challenged by power swings will be determined by the Planning Coordinator in Requirement R1 or by the Generator Owner after becoming aware of a generator, transformer, or transmission line BES Element that tripped<sup>22</sup> in response to a stable or unstable power swing due to the operation of its protective relay(s) in Requirement R2.

<sup>19</sup> Donald Reimert, *Protective Relaying for Power Generation Systems*, Boca Raton, FL, CRC Press, 2006.

<sup>20</sup> Prabha Kundur, *Power System Stability and Control*, EPRI, McGraw Hill, Inc., 1994.

<sup>21</sup> Ibid, Kundur.

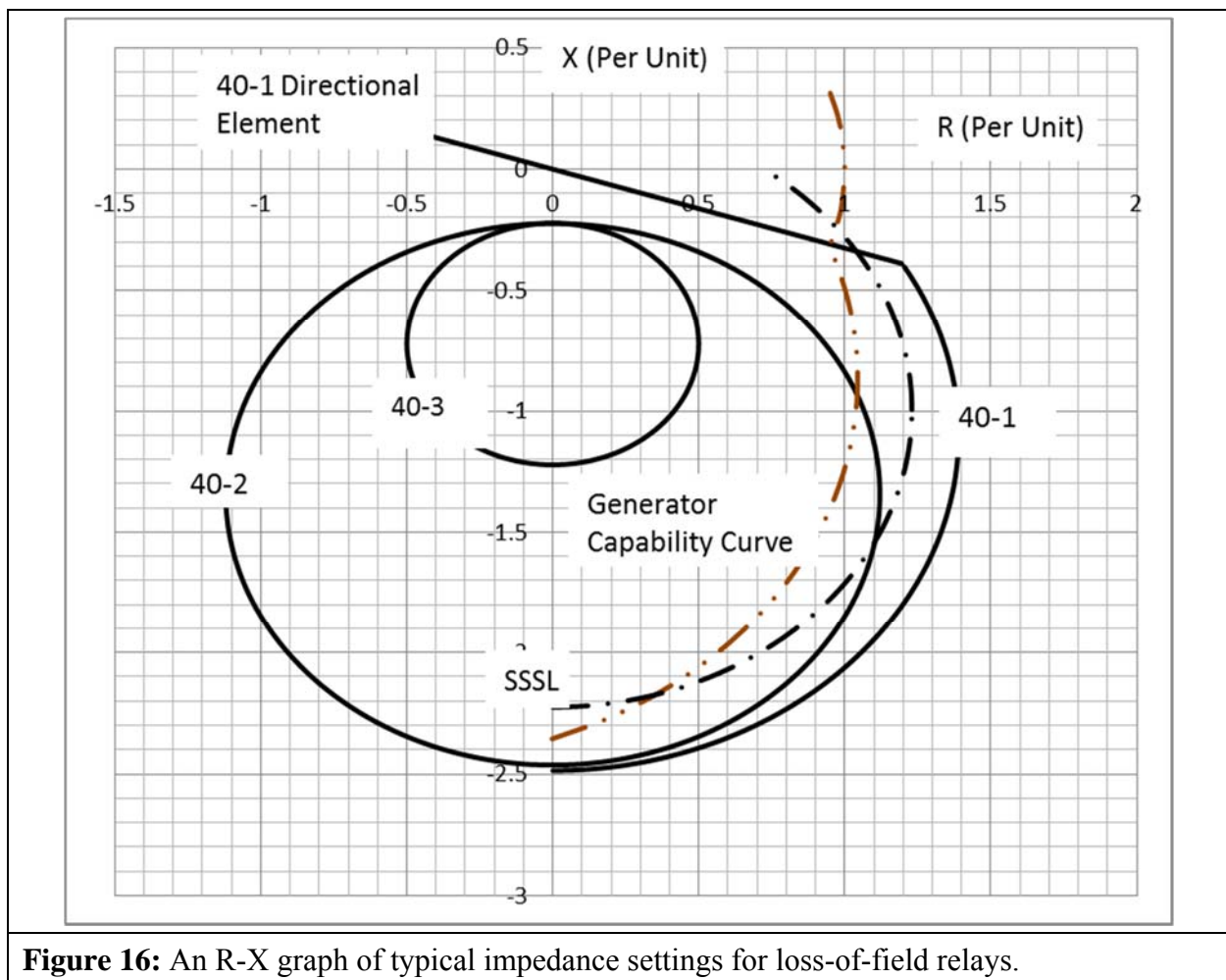
<sup>22</sup> See Guidelines and Technical Basis section, “Becoming Aware of an Element That Tripped in Response to a Power Swing,”

## PRC-026-1 – Application Guidelines

Voltage controlled time-overcurrent and voltage-restrained time-overcurrent relays are excluded from this standard. When these relays are set based on equipment permissible overload capability, their operating times are much greater than 15 cycles for the current levels observed during a power swing.

Instantaneous overcurrent, time-overcurrent, and definite-time overcurrent relays with a time delay of less than 15 cycles for the current levels observed during a power swing are applicable and are required to be evaluated for identified Elements.

The generator loss-of-field protective function is provided by impedance relay(s) connected at the generator terminals. The settings are applied to protect the generator from a partial or complete loss of excitation under all generator loading conditions and, at the same time, be immune to tripping on stable power swings. It is more likely that the loss-of-field relay would operate during a power swing when the automatic voltage regulator (AVR) is in manual mode rather than when in automatic mode.<sup>23</sup> Figure 16 illustrates the loss-of-field relay in the R-X plot, which typically includes up to three zones of protection.



**Figure 16:** An R-X graph of typical impedance settings for loss-of-field relays.

<sup>23</sup> John Burdy, *Loss-of-excitation Protection for Synchronous Generators GER-3183*, General Electric Company.

Loss-of-field characteristic 40-1 has a wider impedance characteristic (positive offset) than characteristic 40-2 or characteristic 40-3 and provides additional generator protection for a partial loss of field or a loss of field under low load (less than 10% of rated). The tripping logic of this protection scheme is established by a directional contact, a voltage setpoint, and a time delay. The voltage and time delay add security to the relay operation for stable power swings. Characteristic 40-3 is less sensitive to power swings than characteristic 40-2 and is set outside the generator capability curve in the leading direction. Regardless of the relay impedance setting, PRC-019<sup>24</sup> requires that the “in-service limiters operate before Protection Systems to avoid unnecessary trip” and “in-service Protection System devices are set to isolate or de-energize equipment in order to limit the extent of damage when operating conditions exceed equipment capabilities or stability limits.” Time delays for tripping associated with loss-of-field relays<sup>25,26</sup> have a range from 15 cycles for characteristic 40-2 to 60 cycles for characteristic 40-1 to minimize tripping during stable power swings. In PRC-026-1, 15 cycles establishes a threshold for applicability; however, it is the responsibility of the Generator Owner to establish settings that provide security against stable power swings and, at the same time, dependable protection for the generator.

The simple two-machine system circuit (method also used in the Application to Transmission Elements section) is used to analyze the effect of a power swing at a generator facility for load-responsive relays. In this section, the calculation method is used for calculating the impedance seen by the relay connected at a point in the circuit.<sup>27</sup> The electrical quantities used to determine the apparent impedance plot using this method are generator saturated transient reactance ( $X'_d$ ), GSU transformer impedance ( $X_{GSU}$ ), transmission line impedance ( $Z_L$ ), and the system equivalent ( $Z_e$ ) at the point of interconnection. All impedance values are known to the Generator Owner except for the system equivalent. The system equivalent is obtainable from the Transmission Owner. The sending-end and receiving-end source voltages are varied from 0.0 to 1.0 per unit to form the lens shape portion of the unstable power swing region. The voltage range of 0.7 to 1.0 results in a ratio range from 0.7 to 1.43. This ratio range is used to form the lower and upper loss-of-synchronism circle shapes of the unstable power swing region. A system separation angle of 120 degrees is used in accordance with PRC-026-1 – Attachment B criteria for each load-responsive protective relay evaluation.

Table 15 below is an example calculation of the apparent impedance locus method based on Figures 17 and 18.<sup>28</sup> In this example, the generator is connected to the 345 kV transmission system through the GSU transformer and has the listed ratings. Note that the load-responsive protective relays in this example may have ownership with the Generator Owner or the Transmission Owner.

---

<sup>24</sup> Coordination of Generating Unit or Plant Capabilities, Voltage Regulating Controls, and Protection

<sup>25</sup> Ibid, Burdy.

<sup>26</sup> *Applied Protective Relaying*, Westinghouse Electric Corporation, 1979.

<sup>27</sup> Edward Wilson Kimbark, *Power System Stability, Volume II: Power Circuit Breakers and Protective Relays*, Published by John Wiley and Sons, 1950.

<sup>28</sup> Ibid, Kimbark.

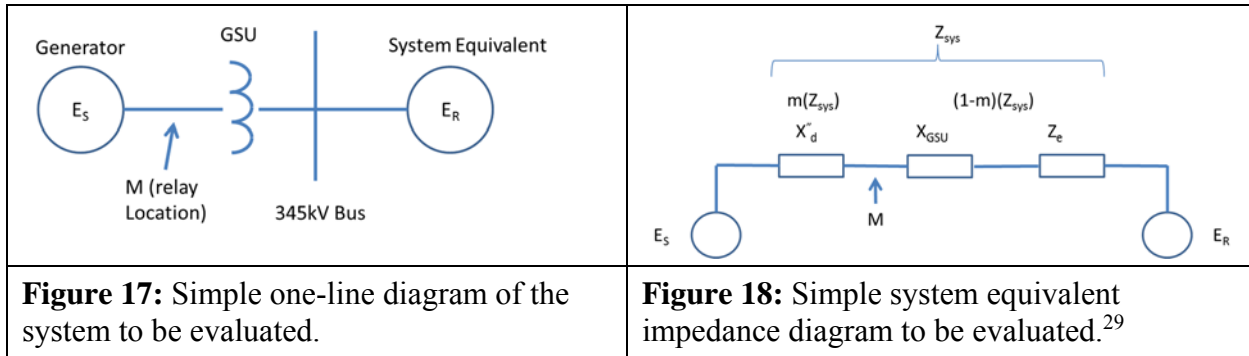


Table15: Example Data (Generator)	
Input Descriptions	Input Values
Synchronous Generator nameplate (MVA)	940 MVA
Saturated transient reactance (940 MVA base)	$X'_d = 0.3845$ per unit
Generator rated voltage (Line-to-Line)	20 kV
Generator step-up (GSU) transformer rating	880 MVA
GSU transformer reactance (880 MVA base)	$X_{GSU} = 16.05\%$
System Equivalent (100 MVA base)	$Z_e = 0.00723 \angle 90^\circ$ per unit
Generator Owner Load-Responsive Protective Relays	
40-1	Positive Offset Impedance
	Offset = 0.294 per unit
	Diameter = 0.294 per unit
40-2	Negative Offset Impedance
	Offset = 0.22 per unit
	Diameter = 2.24 per unit
40-3	Negative Offset Impedance
	Offset = 0.22 per unit
	Diameter = 1.00 per unit
21-1	Diameter = 0.643 per unit
	MTA = 85°

<sup>29</sup> Ibid, Kimbark.

Table15: Example Data (Generator)	
50	I (pickup) = 5.0 per unit
Transmission Owned Load-Responsive Protective Relays	
21-2	Diameter = 0.55 per unit
	MTA = 85°

Calculations shown for a 120 degree angle and  $E_S/E_R = 1$ . The equation for calculating  $Z_R$  is:<sup>30</sup>

$$\text{Eq. (106)} \quad Z_R = \left( \frac{(1 - m)(E_S \angle \delta) + (m)(E_R)}{E_S \angle \delta - E_R} \right) \times Z_{sys}$$

Where m is the relay location as a function of the total impedance (real number less than 1)

$E_S$  and  $E_R$  is the sending-end and receiving-end voltages

$Z_{sys}$  is the total system impedance

$Z_R$  is the complex impedance at the relay location and plotted on an R-X diagram

All of the above are constants (940 MVA base) while the angle  $\delta$  is varied. Table 16 below contains calculations for a generator using the data listed in Table 15.

Table16: Example Calculations (Generator)			
The following calculations are on a 940 MVA base.			
Given:	$X'_d = j0.3845 pu$	$X_{GSU} = j0.17144 pu$	$Z_e = j0.06796 pu$
Eq. (107)	$Z_{sys} = X'_d + X_{GSU} + Z_e$		
	$Z_{sys} = j0.3845 pu + j0.17144 pu + j0.06796 pu$		
	$Z_{sys} = 0.6239 \angle 90^\circ pu$		
Eq. (108)	$m = \frac{X'_d}{Z_{sys}} = \frac{0.3845}{0.6239} = 0.6163$		
Eq. (109)	$Z_R = \left( \frac{(1 - m)(E_S \angle \delta) + (m)(E_R)}{E_S \angle \delta - E_R} \right) \times Z_{sys}$		
	$Z_R = \left( \frac{(1 - 0.6163) \times (1 \angle 120^\circ) + (0.6163)(1 \angle 0^\circ)}{1 \angle 120^\circ - 1 \angle 0^\circ} \right) \times (0.6239 \angle 90^\circ) pu$		

<sup>30</sup> Ibid, Kimbark.



Table16: Example Calculations (Generator)	
	$Z_R = \left( \frac{0.4244 + j0.3323}{-1.5 + j 0.866} \right) \times (0.6239 \angle 90^\circ) pu$
	$Z_R = (0.3116 \angle -111.95^\circ) \times (0.6239 \angle 90^\circ) pu$
	$Z_R = 0.194 \angle -21.95^\circ pu$
	$Z_R = -0.18 - j0.073 pu$

Table 17 lists the swing impedance values at other angles and at  $E_S/E_R = 1, 1.43,$  and  $0.7$ . The impedance values are plotted on an R-X graph with the center being at the generator terminals for use in evaluating impedance relay settings.

Table 17: Sample Calculations for a Swing Impedance Chart for Varying Voltages at the Sending-End and Receiving-End.						
Angle ( $\delta$ ) (Degrees)	$E_S/E_R=1$		$E_S/E_R=1.43$		$E_S/E_R=0.7$	
	$Z_R$		$Z_R$		$Z_R$	
	Magnitude (pu)	Angle (Degrees)	Magnitude (pu)	Angle (Degrees)	Magnitude (pu)	Angle (Degrees)
90	0.320	-13.1	0.296	6.3	0.344	-31.5
120	0.194	-21.9	0.173	-0.4	0.227	-40.1
150	0.111	-41.0	0.082	-10.3	0.154	-58.4
210	0.111	-25.9	0.082	190.3	0.154	238.4
240	0.194	201.9	0.173	180.4	0.225	220.1
270	0.320	193.1	0.296	173.7	0.344	211.5

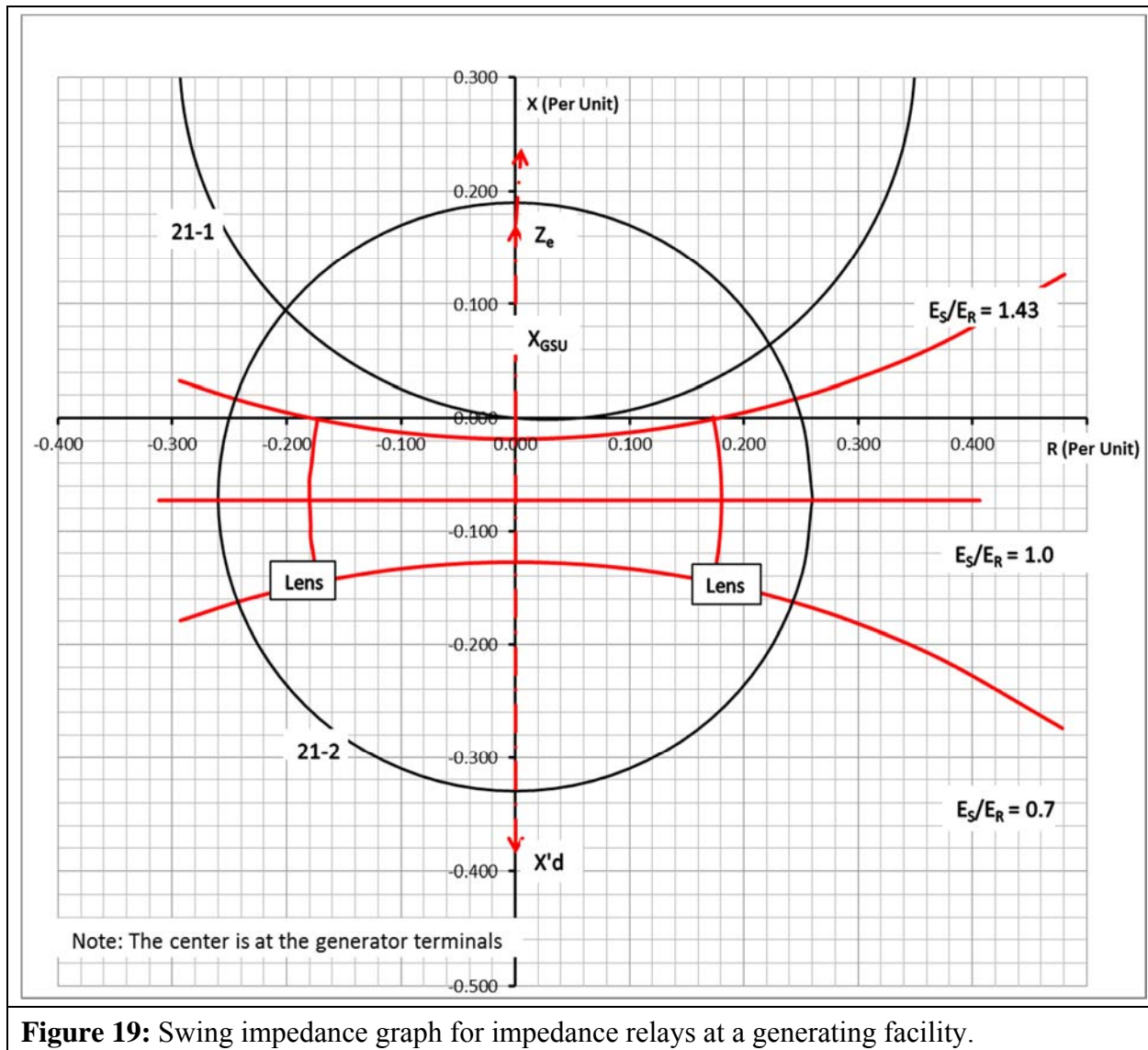
## Requirement R2 Generator Examples

### ***Distance Relay Application***

Based on PRC-026-1 – Attachment B, Criterion A, the distance relay (21-1) (i.e., owned by the Generation Owner) characteristic is in the region where a stable power swing would not occur as shown in Figure 19. There is no further obligation to the owner in this standard for this load-responsive protective relay.

The distance relay (21-2) (i.e., owned by the Transmission Owner) is connected at the high-voltage side of the GSU transformer and its impedance characteristic is in the region where a stable power swing could occur causing the relay to operate. In this example, if the intentional time delay of this relay is less than 15 cycles, the PRC-026 – Attachment B, Criterion A cannot be met, thus the Transmission Owner is required to create a CAP (Requirement R3). Some of the options include,

but are not limited to, changing the relay setting (i.e., impedance reach, angle, time delay), modify the scheme (i.e., add PSB), or replace the Protection System. Note that the relay may be excluded from this standard if it has an intentional time delay equal to or greater than 15 cycles.

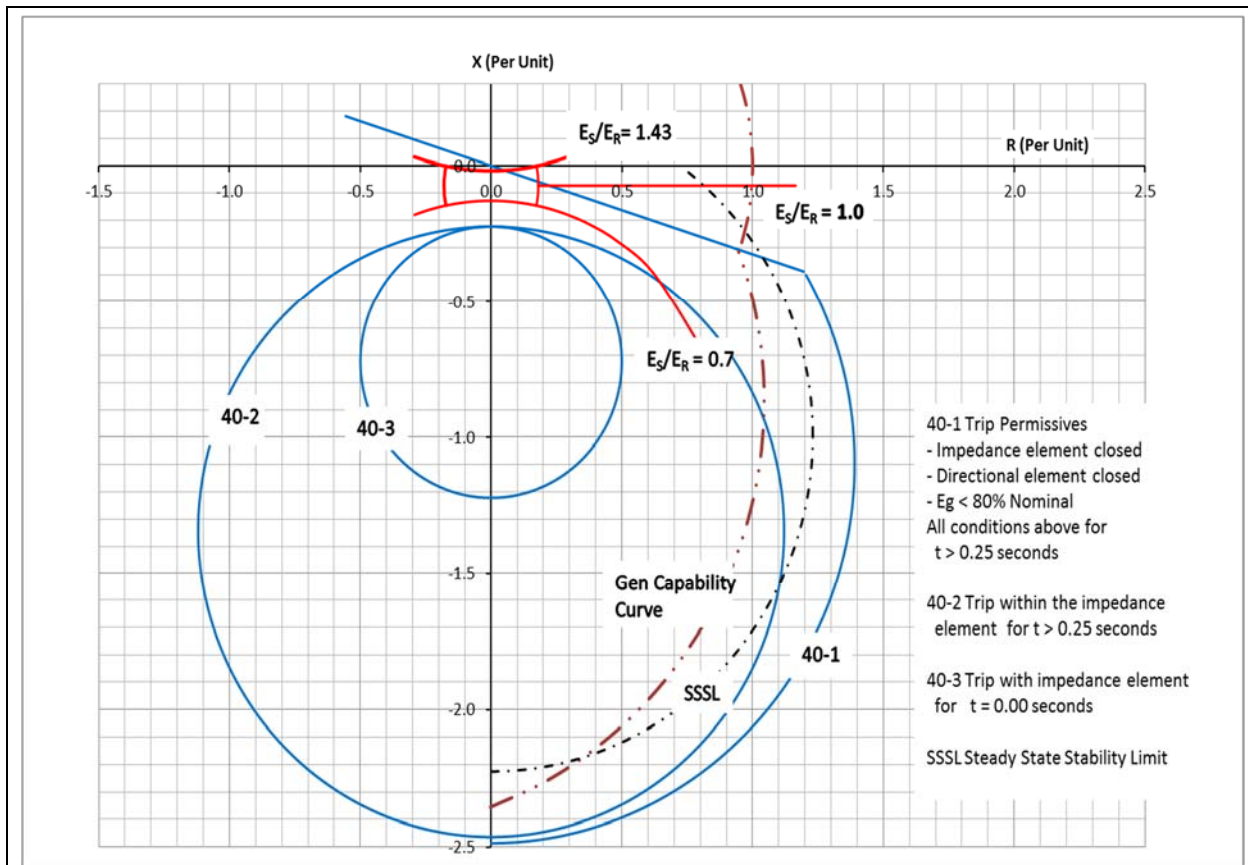


**Loss-of-Field Relay Application**

In Figure 20, the R-X diagram shows the loss-of-field relay (40-1 and 40-2) characteristics are in the region where a stable power swing can cause a relay operation. Protective relay 40-1 would be excluded if it has an intentional time delay equal to or greater than 15 cycles. Similarly, 40-2 would be excluded if its intentional time delay is equal to or greater than 15 cycles. For example, if 40-1 has a time delay of 1 second and 40-2 has a time delay of 0.25 seconds, they are excluded and there is no further obligation on the Generator Owner in this standard for these relays. The

## PRC-026-1 – Application Guidelines

loss-of-field relay characteristic 40-3 is entirely inside the unstable power swing region. In this case, the owner may select high speed tripping on operation of the 40-3 impedance element.



**Figure 20:** Typical R-X graph for loss-of-field relays with a portion of the unstable power swing region defined by PRC-026-1 – Attachment B, Criterion A.

### Instantaneous Overcurrent Relay

In similar fashion to the transmission line overcurrent example calculation in Table 14, the instantaneous overcurrent relay minimum setting is established by PRC-026-1 – Attachment B, Criterion B. The solution is found by:

$$\text{Eq. (110)} \quad I_{sys} = \frac{E_S - E_R}{Z_{sys}}$$

As stated in the relay settings in Table 15, the relay is installed on the high-voltage side of the GSU transformer with a pickup of 5.0 per unit. The maximum allowable current is calculated below.

$$I_{sys} = \frac{(1.05 \angle 120^\circ - 1.05 \angle 0^\circ)}{0.6239 \angle 90^\circ} \text{ pu}$$

$$I_{sys} = \frac{1.819 \angle 150^\circ}{0.6239 \angle 90^\circ} pu$$

$$I_{sys} = 2.91 \angle 60^\circ pu$$

The instantaneous phase setting of 5.0 per unit is greater than the calculated system current of 2.91 per unit; therefore, it meets the PRC-026-1 – Attachment B, Criterion B.

### ***Out-of-Step Tripping for Generation Facilities***

Out-of-step protection for the generator generally falls into three different schemes. The first scheme is a distance relay connected at the high-voltage side of the GSU transformer with the directional element looking toward the generator. Because this relay setting may be the same setting used for generator backup protection (see Requirement R2 Generator Examples, Distance Relay Application), it is susceptible to tripping in response to stable power swings and would require modification. Because this scheme is susceptible to tripping in response to stable power swings and any modification to the mho circle will jeopardize the overall protection of the out-of-step protection of the generator, available technical literature does not recommend using this scheme specifically for generator out-of-step protection. The second and third out-of-step Protection System schemes are commonly referred to as single and double blinder schemes. These schemes are installed or enabled for out-of-step protection using a combination of blinders, a mho element, and timers. The combination of these protective relay functions provides out-of-step protection and discrimination logic for stable and unstable power swings. Single blinder schemes use logic that discriminate between stable and unstable power swings by issuing a trip command after the first slip cycle. Double blinder schemes are more complex than the single blinder scheme and, depending on the settings of the inner blinder, a trip for a stable power swing may occur. While the logic discriminates between stable and unstable power swings in either scheme, it is important that the trip initiating blinders be set at an angle greater than the stability limit of 120 degrees to remove the possibility of a trip for a stable power swing. Below is a discussion of the double blinder scheme.

### ***Double Blinder Scheme***

The double blinder scheme is a method for measuring the rate of change of positive sequence impedance for out-of-step swing detection. The scheme compares a timer setting to the actual elapsed time required by the impedance locus to pass between two impedance characteristics. In this case, the two impedance characteristics are simple blinders, each set to a specific resistive reach on the R-X plane. Typically, the two blinders on the left half plane are the mirror images of those on the right half plane. The scheme typically includes a mho characteristic which acts as a starting element, but is not a tripping element.

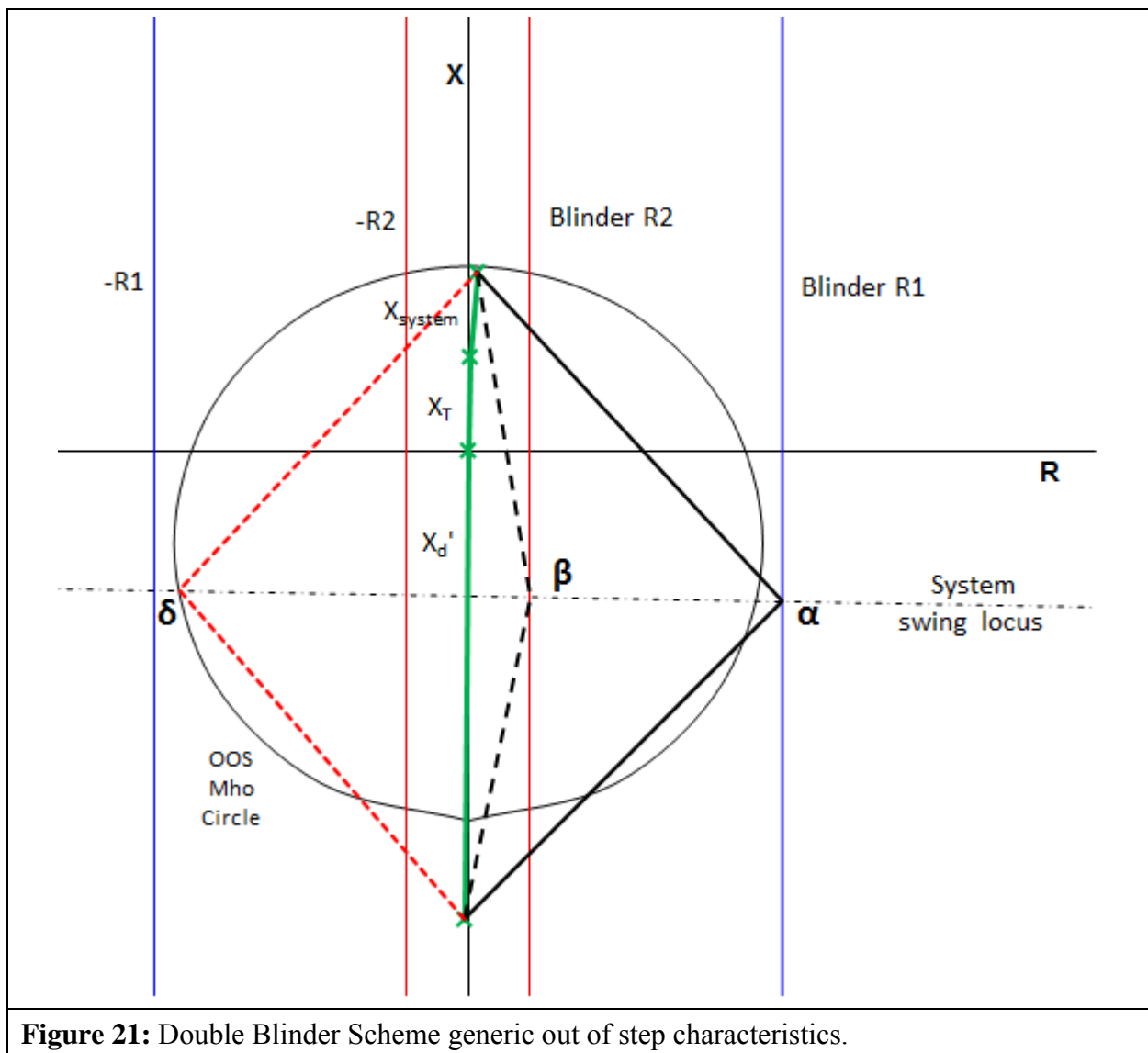
The scheme detects the blinder crossings and time delays as represented on the R-X plane as shown in Figure 21. The system impedance is composed of the generator transient ( $X_d'$ ), GSU transformer ( $X_T$ ), and transmission system ( $X_{system}$ ), impedances.

The scheme logic is initiated when the swing locus crosses the outer Blinder R1 (Figure 21), on the right at separation angle  $\alpha$ . The scheme only commits to take action when a swing crosses the

## PRC-026-1 – Application Guidelines

inner blinder. At this point the scheme logic seals in the out-of-step trip logic at separation angle  $\beta$ . Tripping actually asserts as the impedance locus leaves the scheme characteristic at separation angle  $\delta$ .

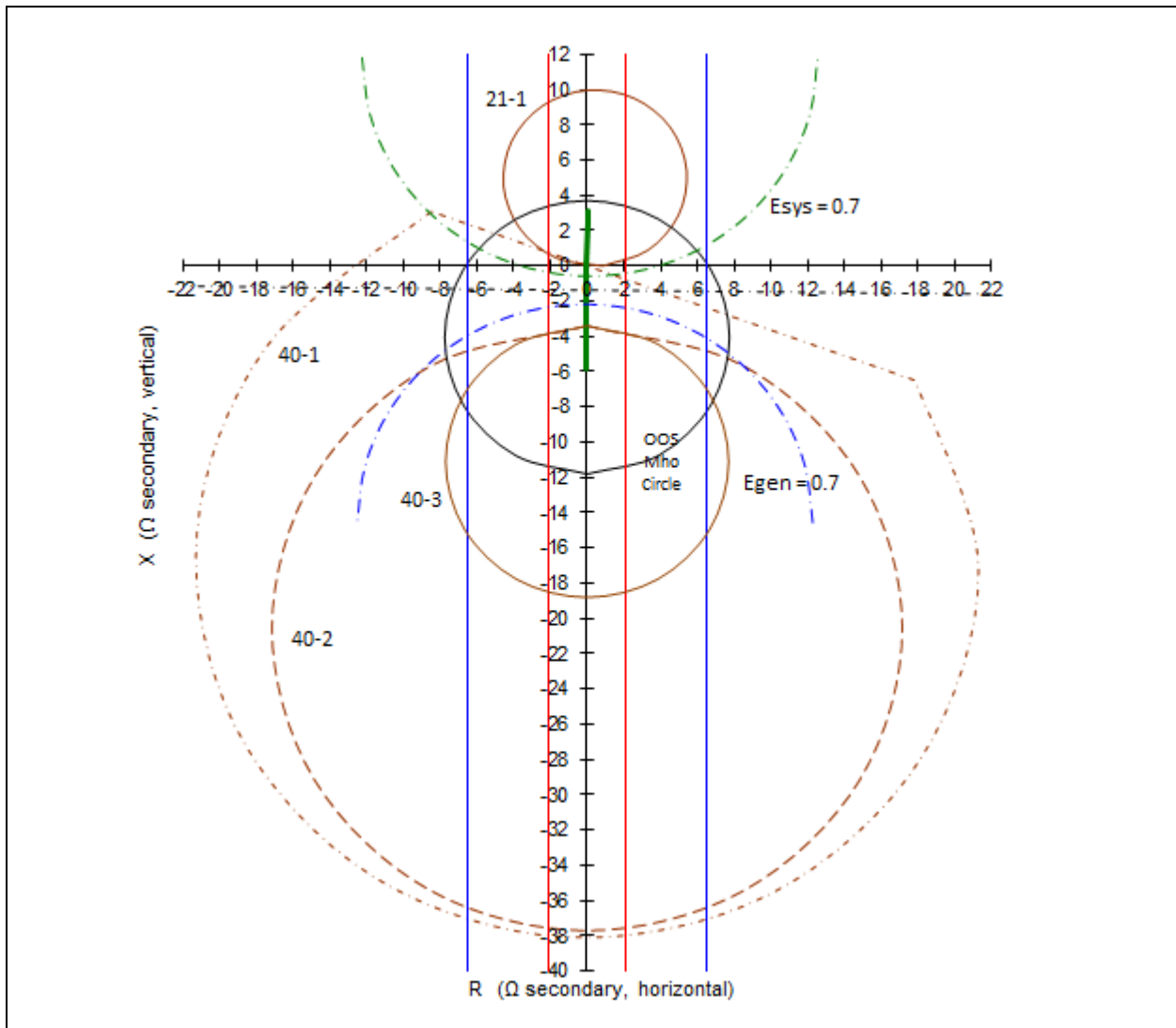
The power swing may leave both inner and outer blinders in either direction, and tripping will assert. Therefore, the inner blinder must be set such that the separation angle  $\beta$  is large enough that the system cannot recover. This angle should be set at 120 degrees or more. Setting the angle greater than 120 degrees satisfies the PRC-026-1 – Attachment B, Criterion A (No. 1, 1<sup>st</sup> bullet) since the tripping function is asserted by the blinder element. Transient stability studies may indicate that a smaller stability limit angle is acceptable under PRC-026-1 – Attachment B, Criterion A (No. 1, 2<sup>nd</sup> bullet). In this respect, the double blinder scheme is similar to the double lens and triple lens schemes and many transmission application out-of-step schemes.



**Figure 21:** Double Blinder Scheme generic out of step characteristics.

## PRC-026-1 – Application Guidelines

Figure 22 illustrates a sample setting of the double blinder scheme for the example 940 MVA generator. The only setting requirement for this relay scheme is the right inner blinder, which must be set greater than the separation angle of 120 degrees (or a lesser angle based on a transient stability study) to ensure that the out-of-step protective function is expected to not trip in response to a stable power swing during non-Fault conditions. Other settings such as the mho characteristic, outer blinders, and timers are set according to transient stability studies and are not a part of this standard.



**Figure 22:** Double Blinder Out-of-Step Scheme with unit impedance data and load-responsive protective relay impedance characteristics for the example 940 MVA generator, scaled in relay secondary ohms.

### Requirement R3

To achieve the stated purpose of this standard, which is to ensure that relays are expected to not trip in response to stable power swings during non-Fault conditions, this Requirement ensures that the applicable entity develops a Corrective Action Plan (CAP) that reduces the risk of relays tripping in response to a stable power swing during non-Fault conditions that may occur on any applicable BES Element.

### Requirement R4

To achieve the stated purpose of this standard, which is to ensure that load-responsive protective relays are expected to not trip in response to stable power swings during non-Fault conditions, the applicable entity is required to implement any CAP developed pursuant to Requirement R3 such that the Protection System will meet PRC-026-1 – Attachment B criteria or can be excluded under the PRC-026-1 – Attachment A criteria (e.g., modifying the Protection System so that relay functions are supervised by power swing blocking or using relay systems that are immune to power swings), while maintaining dependable fault detection and dependable out-of-step tripping (if out-of-step tripping is applied at the terminal of the BES Element). Protection System owners are required in the implementation of a CAP to update it when actions or timetable change, until all actions are complete. Accomplishing this objective is intended to reduce the occurrence of Protection System tripping during a stable power swing, thereby improving reliability and minimizing risk to the BES.

The following are examples of actions taken to complete CAPs for a relay that did not meet PRC-026-1 – Attachment B and could be at-risk of tripping in response to a stable power swing during non-Fault conditions. A Protection System change was determined to be acceptable (without diminishing the ability of the relay to protect for faults within its zone of protection).

**Example R4a:** Actions: Settings were issued on 6/02/2015 to reduce the Zone 2 reach of the impedance relay used in the directional comparison unblocking (DCUB) scheme from 30 ohms to 25 ohms so that the relay characteristic is completely contained within the lens characteristic identified by the criterion. The settings were applied to the relay on 6/25/2015. CAP was completed on 06/25/2015.

**Example R4b:** Actions: Settings were issued on 6/02/2015 to enable out-of-step blocking on the existing microprocessor-based relay to prevent tripping in response to stable power swings. The setting changes were applied to the relay on 6/25/2015. CAP was completed on 06/25/2015.

## PRC-026-1 – Application Guidelines

The following is an example of actions taken to complete a CAP for a relay responding to a stable power swing that required the addition of an electromechanical power swing blocking relay.

**Example R4c:** Actions: A project for the addition of an electromechanical power swing blocking relay to supervise the Zone 2 impedance relay was initiated on 6/5/2015 to prevent tripping in response to stable power swings. The relay installation was completed on 9/25/2015. CAP was completed on 9/25/2015.

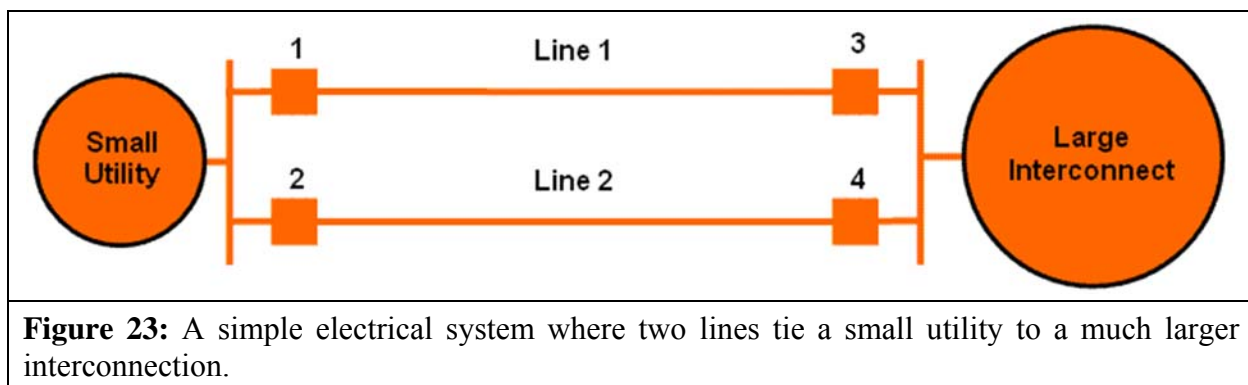
The following is an example of actions taken to complete a CAP with a timetable that required updating for the replacement of the relay.

**Example R4d:** Actions: A project for the replacement of the impedance relays at both terminals of line X with line current differential relays was initiated on 6/5/2015 to prevent tripping in response to stable power swings. The completion of the project was postponed due to line outage rescheduling from 11/15/2015 to 3/15/2016. Following the timetable change, the impedance relay replacement was completed on 3/18/2016. CAP was completed on 3/18/2016.

The CAP is complete when all the documented actions to remedy the specific problem (i.e., unnecessary tripping during stable power swings) are completed.

### Justification for Including Unstable Power Swings in the Requirements

Protection Systems that are applicable to the Standard and must be secure for a stable power swing condition (i.e., meets PRC-026-1 – Attachment B criteria) are identified based on Elements that are susceptible to both stable and unstable power swings. This section provides an example of why Elements that trip in response to unstable power swings (in addition to stable power swings) are identified and that their load-responsive protective relays need to be evaluated under PRC-026-1 – Attachment B criteria.

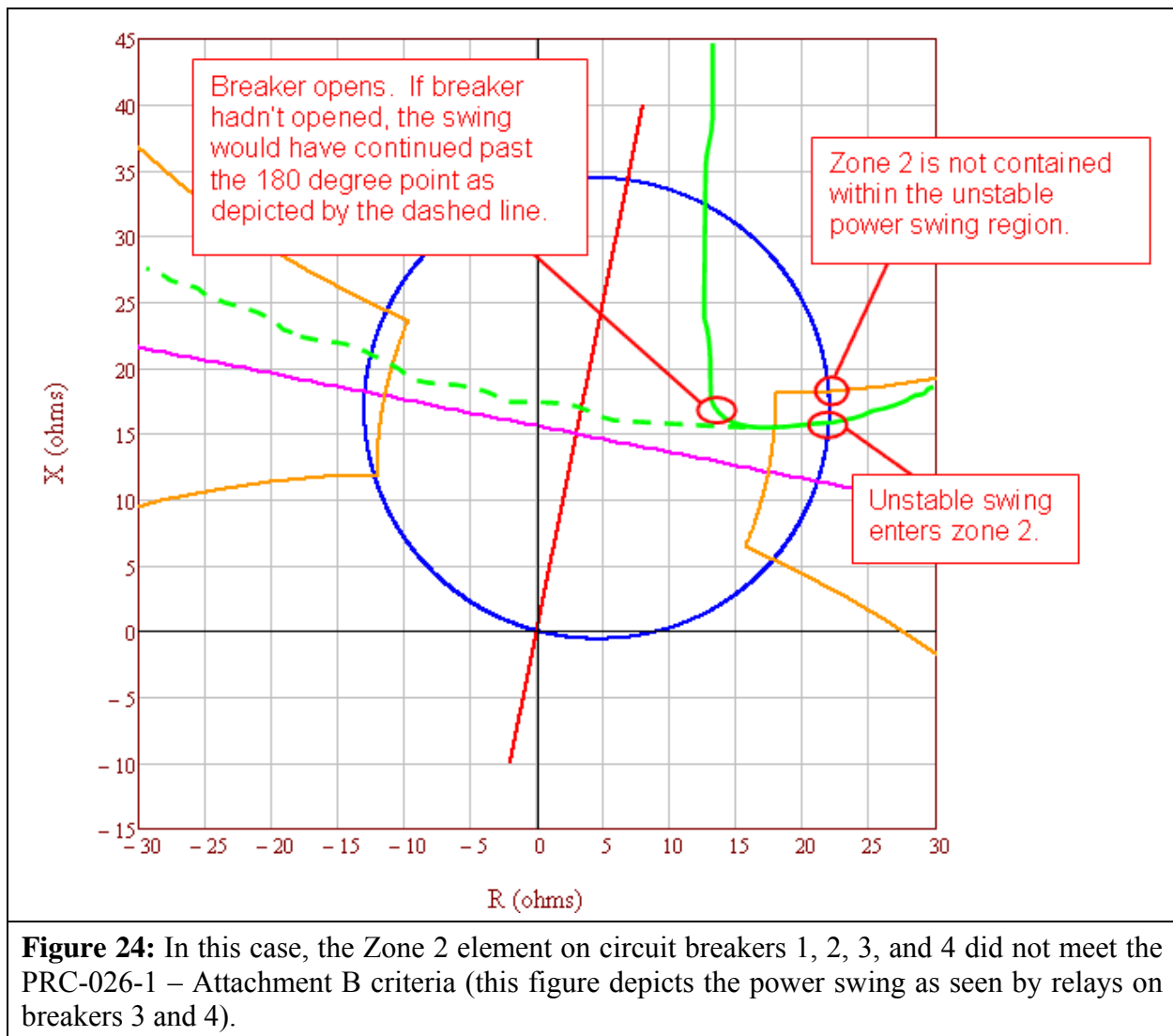


In Figure 23 the relays at circuit breakers 1, 2, 3, and 4 are equipped with a typical overreaching Zone 2 pilot system, using a Directional Comparison Blocking (DCB) scheme. Internal faults (or power swings) will result in instantaneous tripping of the Zone 2 relays if the measured fault or power swing impedance falls within the zone 2 operating characteristic. These lines will trip on

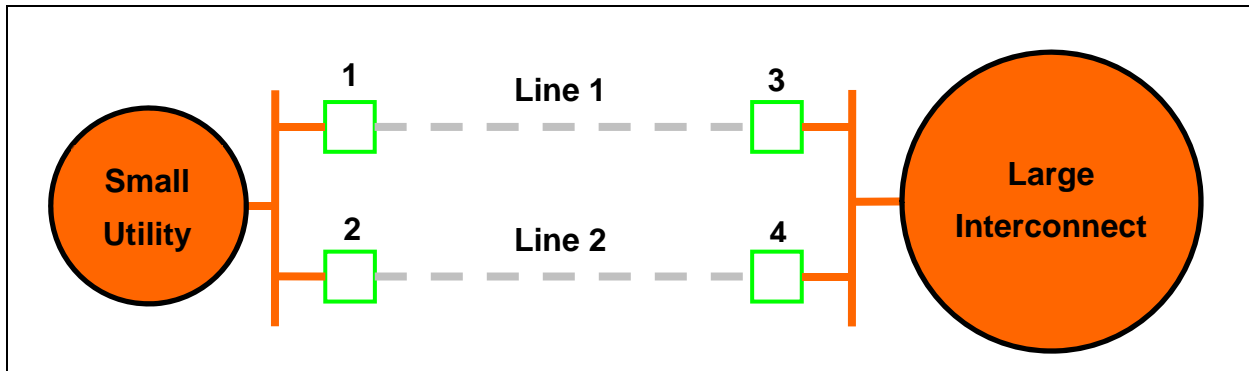


## PRC-026-1 – Application Guidelines

pilot Zone 2 for out-of-step conditions if the power swing impedance characteristic enters into Zone 2. All breakers are rated for out-of-phase switching.

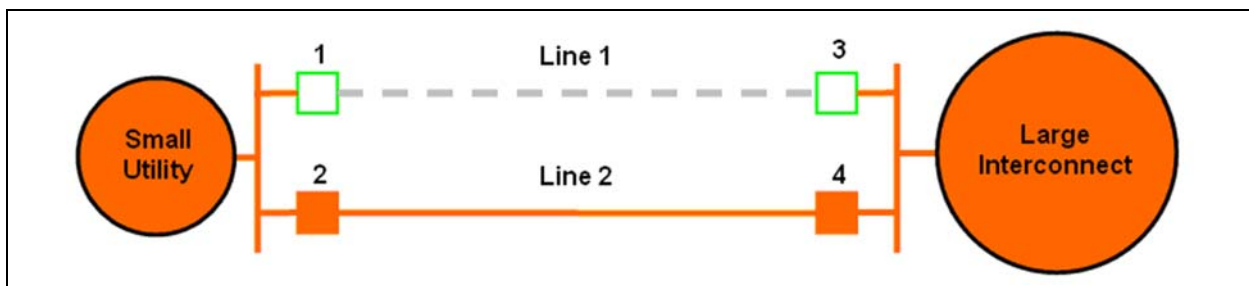


In Figure 24, a large disturbance occurs within the small utility and its system goes out-of-step with the large interconnect. The small utility is importing power at the time of the disturbance. The actual power swing, as shown by the solid green line, enters the Zone 2 relay characteristic on the terminals of Lines 1, 2, 3, and 4 causing both lines to trip as shown in Figure 25.



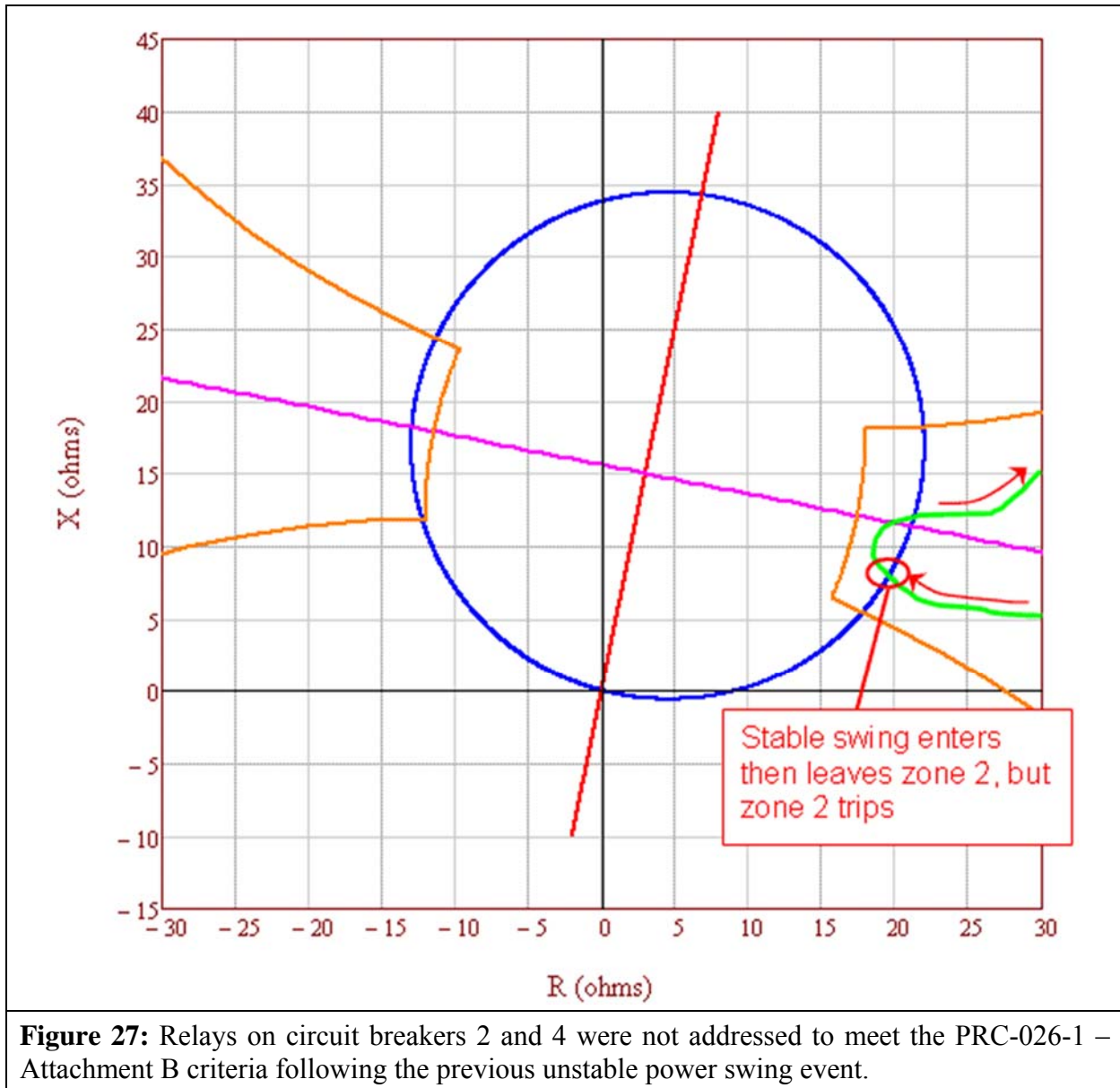
**Figure 25:** Islanding of the small utility due to Lines 1 and 2 tripping in response to an unstable power swing.

In Figure 25, the relays at circuit breakers 1, 2, 3, and 4 have correctly tripped due to the unstable power swing (shown by the dashed green line in Figure 24), de-energizing Lines 1 and 2, and creating an island between the small utility and the big interconnect. The small utility shed 500 MW of load on underfrequency and maintained a load to generation balance.

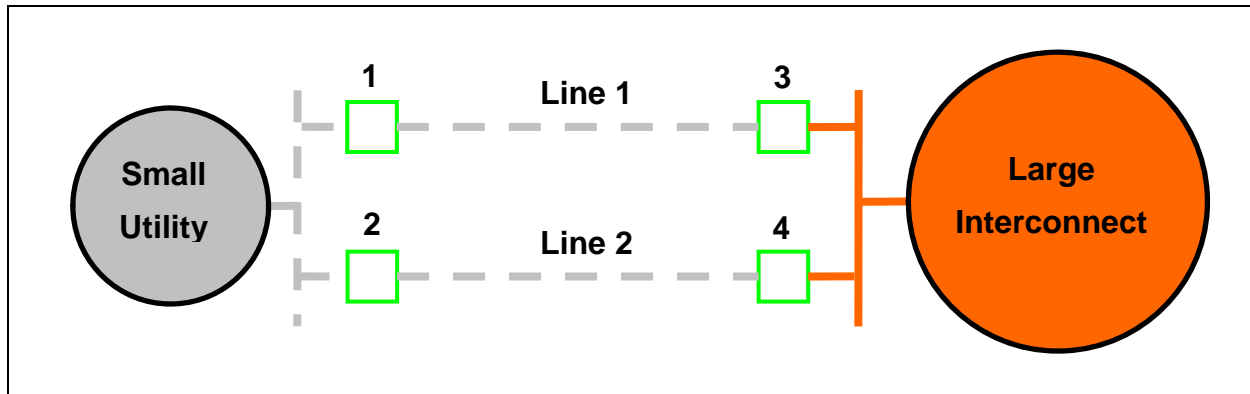


**Figure 26:** Line 1 is out-of-service for maintenance, Line 2 is loaded beyond its normal rating (but within its emergency rating).

Subsequent to the correct tripping of Lines 1 and 2 for the unstable power swing in Figure 25, another system disturbance occurs while the system is operating with Line 1 out-of-service for maintenance. The disturbance causes a stable power swing on Line 2, which challenges the relays at circuit breakers 2 and 4 as shown in Figure 27.



If the relays on circuit breakers 2 and 4 were not addressed under the Requirements for the previous unstable power swing condition, the relays would trip in response to the stable power swing, which would result in unnecessary system separation, load shedding, and possibly cascading or blackout.



**Figure 28:** Possible blackout of the small utility.

If the relays that tripped in response to the previous unstable power swing condition in Figure 24 were addressed under the Requirements to meet PRC-026-1 - Attachment B criteria, the unnecessary tripping of the relays for the stable power swing shown in Figure 28 would have been averted, and the possible blackout of the small utility would have been avoided.

### Rationale

During development of this standard, text boxes were embedded within the standard to explain the rationale for various parts of the standard. Upon BOT approval, the text from the rationale text boxes was moved to this section.

#### Rationale for R1

The Planning Coordinator has a wide-area view and is in the position to identify generator, transformer, and transmission line BES Elements which meet the criteria, if any. The criteria-based approach is consistent with the NERC System Protection and Control Subcommittee (SPCS) technical document *Protection System Response to Power Swings*, August 2013 (“PSRPS Report”),<sup>31</sup> which recommends a focused approach to determine an at-risk BES Element. See the Guidelines and Technical Basis for a detailed discussion of the criteria.

#### Rationale for R2

The Generator Owner and Transmission Owner are in a position to determine whether their load-responsive protective relays meet the PRC-026-1 – Attachment B criteria. Generator, transformer, and transmission line BES Elements are identified by the Planning Coordinator in Requirement R1 and by the Generator Owner and Transmission Owner following an actual event where the Generator Owner and Transmission Owner became aware (i.e., through an event analysis or

---

<sup>31</sup> NERC System Protection and Control Subcommittee, *Protection System Response to Power Swings*, August 2013:  
[http://www.nerc.com/comm/PC/System%20Protection%20and%20Control%20Subcommittee%20SPCS%202020/SPCS%20Power%20Swing%20Report\\_Final\\_20131015.pdf](http://www.nerc.com/comm/PC/System%20Protection%20and%20Control%20Subcommittee%20SPCS%202020/SPCS%20Power%20Swing%20Report_Final_20131015.pdf)

## **PRC-026-1 – Application Guidelines**

---

Protection System review) tripping was due to a stable or unstable power swing. A period of 12 calendar months allows sufficient time for the entity to conduct the evaluation.

### **Rationale for R3**

To meet the reliability purpose of the standard, a CAP is necessary to ensure the entity's Protection System meets the PRC-026-1 – Attachment B criteria (1<sup>st</sup> bullet) so that protective relays are expected to not trip in response to stable power swings. A CAP may also be developed to modify the Protection System for exclusion under PRC-026-1 – Attachment A (2<sup>nd</sup> bullet). Such an exclusion will allow the Protection System to be exempt from the Requirement for future events. The phrase, "...while maintaining dependable fault detection and dependable out-of-step tripping..." in Requirement R3 describes that the entity is to comply with this standard, while achieving their desired protection goals. Refer to the Guidelines and Technical Basis, Introduction, for more information.

### **Rationale for R4**

Implementation of the CAP must accomplish all identified actions to be complete to achieve the desired reliability goal. During the course of implementing a CAP, updates may be necessary for a variety of reasons such as new information, scheduling conflicts, or resource issues. Documenting CAP changes and completion of activities provides measurable progress and confirmation of completion.

### **Rationale for Attachment B (Criterion A)**

The PRC-026-1 – Attachment B, Criterion A provides a basis for determining if the relays are expected to not trip for a stable power swing having a system separation angle of up to 120 degrees with the sending-end and receiving-end voltages varying from 0.7 to 1.0 per unit (See Guidelines and Technical Basis).

**Exhibit B**  
**Implementation Plan**

## Implementation Plan

### Project 2010-13.3 – Relay Loadability: Stable Power Swings

#### Requested Approvals

PRC-026-1 – Relay Performance During Stable Power Swings

#### Requested Retirements

None.

#### Prerequisite Approvals

None.

#### General Considerations

There are a number of factors that influenced the determination of an implementation period for the new proposed standard. The following factors may be specific to one or more of the applicable entities listed below.

1. The effort and resources for all applicable entities to develop or modify internal processes and/or procedures.
2. The effort and resources for the Planning Coordinator to begin identifying Element(s) according to the criteria in Requirement R1 is based on existing information (e.g., the most recent Planning Assessment).
3. The notification of Elements in Requirement R1 is based on the Planning Coordinator's existing studies (i.e., annual Planning Assessments) and there will be minimal additional effort to identify Elements according to the criteria.
4. The need for the Generator Owner or Transmission Owner to plan for and secure resources (e.g., availability of consultants, if needed) to address the initial influx of Element notifications from the Planning Coordinator during the implementation period of Requirement R2.

#### Applicable Entities

Generator Owner

Planning Coordinator

Transmission Owner

## Effective Dates

### *Requirement R1*

First day of the first full calendar year that is 12 months after the date that the standard is approved by an applicable governmental authority or as otherwise provided for in a jurisdiction where approval by an applicable governmental authority is required for a standard to go into effect. Where approval by an applicable governmental authority is not required, the standard shall become effective on the first day of the first full calendar year that is 12 months after the date the standard is adopted by the NERC Board of Trustees or as otherwise provided for in that jurisdiction.

### *Requirements R2, R3, and R4*

First day of the first full calendar year that is 36 months after the date that the standard is approved by an applicable governmental authority or as otherwise provided for in a jurisdiction where approval by an applicable governmental authority is required for a standard to go into effect. Where approval by an applicable governmental authority is not required, the standard shall become effective on the first day of the first full calendar year that is 36 months after the date the standard is adopted by the NERC Board of Trustees or as otherwise provided for in that jurisdiction.

## Notifications Prior to the Effective Date of Requirement R2

The implementation plan is designed such that the Planning Coordinator will begin notifying the respective Generator Owners and Transmission Owners of any Elements in Requirement R1 based on the effective date language. The 36 months for the Generator Owner and Transmission Owner in Requirement R2 (and Requirements R3 and R4) to become compliant is intended to allow the entity an opportunity to address the initial influx of identified Elements in Requirement R1. There is no obligation on the Generator Owner or Transmission Owner to perform Requirement R2, R3, or R4 until the effective date of these Requirements. Although there is no compliance obligation during the 36 month implementation period, an entity will have the full obligation of Requirements R2, R3, and R4 following the 36 month period. The 36 month implementation period also allows an opportunity for the entity to establish the evaluation of load-responsive protective relays pursuant to Requirement R2 which will provide the point in time that the five year re-evaluation of such relays will occur.

## Justification

The implementation plan is based on the general considerations above and provides sufficient time for the Generator Owner, Planning Coordinator, and Transmission Owner to begin becoming compliant with the standard. The Effective date is constructed such that once the standard is adopted or approved it would become effective on the first day of the first whole calendar year that is 12 months for Requirement R1 and 36 months for Requirements R2, R3, and R4 after applicable adoption or approval.



**Requirement R1** – The Planning Coordinator will have at least one full calendar year to prepare itself to identify any generator, transformer, and transmission line BES Elements that meet the criteria and notify the respective Generator Owner and Transmission Owner of identified Elements, if any, within the allotted timeframe.

**Requirement R2** – The Generator Owner and Transmission Owner will have 36 calendar months to determine if its load-responsive protective relays for an identified Element pursuant to Requirement R1 meet the PRC-026-1 – Attachment B criteria for the initial influx of Elements. Also, both entities are provided an implementation that will allow the entity to conduct initial evaluations of its load-responsive protective relays for an identified Element during the first 36 calendar months of approval.

**Requirement R3** – The implementation period for the development of a Corrective Action Plan (CAP) is set to be consistent with Requirement R2 to begin during the fourth calendar year of adoptions or approvals to address any load-responsive protective relays determined in Requirement R2 not to meet the PRC-026-1 – Attachment B criteria.

**Requirement R4** – The implementation period for this Requirement is set to be consistent with Requirement R3, the development of a CAP.

**Exhibit D**

**Consideration of Issues and Directives**

## Table of Issues and Directives

### Project 2010-13.3 – Relay Loadability: Stable Power Swings

Table of Issues and Directives Associated with PRC-026-1

Source	Issue or Directive Language (including Para. #)	Section and/or Requirement(s)	Consideration of Issue or Directive
FERC Order 733	<b>150.</b> We will not direct the ERO to modify PRC-023-1 to address stable power swings. However, because both NERC and the Task Force have identified undesirable relay operation due to stable power swings as a reliability issue, we direct the ERO to develop a Reliability Standard that requires the use of protective relay systems that can differentiate between faults and stable power swings and, when necessary, phases out protective relay systems that cannot meet this requirement.	All requirements	<p>The PRC-026-1 standard is responsive to this directive by using an equally effective and efficient focused approach for the Planning Coordinator to provide notification of BES Elements according to the Requirement R1 criteria to the respective Generator Owner and Transmission Owner. The criteria used to identify a BES Element are based on the NERC System Protection and Control Subcommittee technical document, <i>Protection System Response to Power Swings</i> (“PSRPS Report”).<sup>1</sup> The specific criteria are based on where power swings are expected to challenge load-responsive protective relays.</p> <p>The criteria include 1) Generator(s) where an angular stability constraint exists that is addressed by a System Operating Limit (SOL) or a Remedial Action Scheme (RAS) and those Elements</p>

<sup>1</sup> NERC System Protection and Control Subcommittee technical document, *Protection System Response to Power Swings*, August 2013: [http://www.nerc.com/comm/PC/System%20Protection%20and%20Control%20Subcommittee%20SPCS%2020/SPCS%20Power%20Swing%20Report\\_Final\\_20131015.pdf](http://www.nerc.com/comm/PC/System%20Protection%20and%20Control%20Subcommittee%20SPCS%2020/SPCS%20Power%20Swing%20Report_Final_20131015.pdf)

<p>We also direct the ERO to file a report no later than 120 days of this Final Rule addressing the issue of protective relay operation due to power swings. The report should include an action plan and timeline that explains how and when the ERO intends to address this issue through its Reliability Standards development process.</p> <p><b>AND</b></p> <p><b>153.</b> While we recognize that addressing stable power swings is a complex issue, we note that more than six years have passed since the August 2003 blackout and there is still no Reliability Standard that addresses relays tripping due to stable power swings. Additionally, NERC has long identified undesirable relay operation due to stable power swings as a reliability issue. Consequently, pursuant to section 215(d)(5) of the FPA, we find that undesirable relay operation due to stable power swings is a specific matter that the ERO must address to carry out the goals of section 215, and we direct the ERO to develop a Reliability Standard</p>	<p>terminating at the Transmission station associated with the generator(s); 2) An Element that is monitored as part of an SOL identified by the Planning Coordinator’s methodology based on an angular stability constraint; 3) An Element that forms the boundary of an island in the most recent underfrequency load shedding (UFLS) design assessment based on application of the Planning Coordinator’s criteria for identifying islands, only if the island is formed by tripping the Element based on angular instability; 4) An Element identified in the most recent annual Planning Assessment where relay tripping occurs due to a stable or unstable power swing during a simulated disturbance.</p> <p>Requirement R2 requires the Generator Owner and Transmission Owner to evaluate their load-responsive protective relays that are applied at all of the terminals of each BES Element identified by the Planning Coordinator in Requirement R1 or upon becoming aware of a generator, transformer, or transmission line BES Element that tripped in response to a stable or unstable power swing due to the operation of their protective relay(s). The initial evaluation allows the Generator Owner and Transmission Owner to determine whether their load-responsive protective relays applied at all of the terminals of the BES Element meet the PRC-026-1 – Attachment B criteria. Additionally, the Requirement ensures that the Generator Owner and Transmission Owner must re-evaluate the Protection System</p>
--------------------------------------------------------------------------------------------------------------------------------------------------------------------------------------------------------------------------------------------------------------------------------------------------------------------------------------------------------------------------------------------------------------------------------------------------------------------------------------------------------------------------------------------------------------------------------------------------------------------------------------------------------------------------------------------------------------------------------------------------------------------------------------------------------------------------------------------------------------------------------------------------------------------------------------------------------------------------------------------------------------------------------------------------	---------------------------------------------------------------------------------------------------------------------------------------------------------------------------------------------------------------------------------------------------------------------------------------------------------------------------------------------------------------------------------------------------------------------------------------------------------------------------------------------------------------------------------------------------------------------------------------------------------------------------------------------------------------------------------------------------------------------------------------------------------------------------------------------------------------------------------------------------------------------------------------------------------------------------------------------------------------------------------------------------------------------------------------------------------------------------------------------------------------------------------------------------------------------------------------------------------------------------------------------------------------------------------------------------------------------------------------------------------------------------------------------------------------------------------------------------------------------------------------------------------------------------------------------

	<p>addressing undesirable relay operation due to stable power swings.</p>		<p>on a five year basis should the BES Element continue to be identified by the Planning Coordinator in Requirement R1.</p> <p>Requirement R3 mandates the development of a Corrective Action Plan (CAP) such that the Protection System of a BES Element will meet the PRC-026-1 –Attachment B criteria or the Protection System can be excluded under the PRC-026-1 – Attachment A criteria (e.g., modifying the Protection System so that relay functions are supervised by power swing blocking or using relay systems that are immune to power swings).</p> <p>Requirement R4 mandates that the Generator Owner and Transmission Owner implement each developed CAP in Requirement R3 so that load-responsive protective relays are expected to not trip in response to stable power swings during non-Fault conditions.</p>
	<p><b>162.</b> The PSEG Companies also assert that the Commission’s approach to stable power swings should be inclusive and include “islanding” strategies in conjunction with out-of-step blocking or tripping requirements. We agree with the PSEG Companies and direct the ERO to consider “islanding” strategies that achieve the fundamental performance for all islands in developing the new</p>	<p>Requirement R1, Criterion 3</p>	<p>Islanding strategies were considered during the development of the proposed standard. It was determined that islanding strategies are not an appropriate method to meet the purpose of the proposed standard. Islanding strategies are developed to isolate the system from unstable power swings, which is not prohibited under the proposed standard. The proposed standard’s intent is to ensure that load-responsive protective relays are expected to not trip in response to stable power swings during non-Fault conditions, while maintaining dependable fault detection and dependable out-of-step</p>

	Reliability Standard addressing stable power swings.		tripping (if out-of-step tripping is applied at the terminal of the BES Element).
--	------------------------------------------------------	--	-----------------------------------------------------------------------------------

**Exhibit E**

**NERC System Protection and Control Subcommittee: *Protection System Response to Power Swings***

**NERC**

NORTH AMERICAN ELECTRIC  
RELIABILITY CORPORATION

# Protection System Response to Power Swings

System Protection and Control Subcommittee

August 2013

**RELIABILITY | ACCOUNTABILITY**



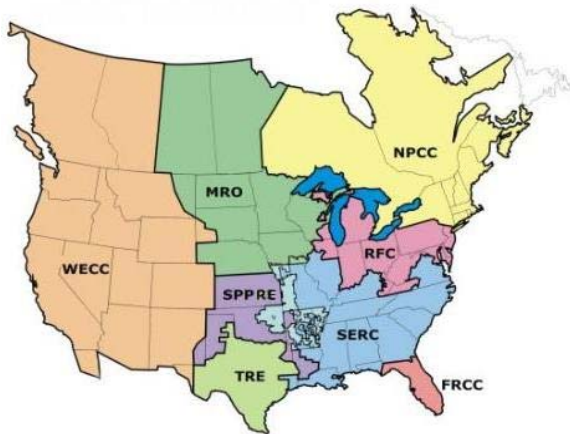
3353 Peachtree Road NE  
Suite 600, North Tower  
Atlanta, GA 30326  
404-446-2560 | [www.nerc.com](http://www.nerc.com)



# NERC's Mission

The North American Electric Reliability Corporation (NERC) is an international regulatory authority established to enhance the reliability of the Bulk-Power System in North America. NERC develops and enforces Reliability Standards; assesses adequacy annually via a ten-year forecast and winter and summer forecasts; monitors the Bulk-Power System; and educates, trains, and certifies industry personnel. NERC is the electric reliability organization for North America, subject to oversight by the U.S. Federal Energy Regulatory Commission (FERC) and governmental authorities in Canada.<sup>1</sup>

NERC assesses and reports on the reliability and adequacy of the North American Bulk-Power System, which is divided into eight Regional areas, as shown on the map and table below. The users, owners, and operators of the Bulk-Power System within these areas account for virtually all the electricity supplied in the U.S., Canada, and a portion of Baja California Norte, México.



**Note:** The highlighted area between SPP RE and SERC denotes overlapping Regional area boundaries. For example, some load serving entities participate in one Region and their associated transmission owner/operators in another.

NERC Regional Entities	
<b>FRCC</b> Florida Reliability Coordinating Council	<b>SERC</b> SERC Reliability Corporation
<b>MRO</b> Midwest Reliability Organization	<b>SPP RE</b> Southwest Power Pool Regional Entity
<b>NPCC</b> Northeast Power Coordinating Council	<b>TRE</b> Texas Reliability Entity
<b>RFC</b> ReliabilityFirst Corporation	<b>WECC</b> Western Electricity Coordinating Council

<sup>1</sup> As of June 18, 2007, the U.S. Federal Energy Regulatory Commission (FERC) granted NERC the legal authority to enforce Reliability Standards with all U.S. users, owners, and operators of the Bulk-Power System, and made compliance with those standards mandatory and enforceable. In Canada, NERC presently has memorandums of understanding in place with provincial authorities in Ontario, New Brunswick, Nova Scotia, Québec, and Saskatchewan, and with the Canadian National Energy Board. NERC standards are mandatory and enforceable in Ontario and New Brunswick as a matter of provincial law. NERC has an agreement with Manitoba Hydro making Reliability Standards mandatory for that entity, and Manitoba has recently adopted legislation setting out a framework for standards to become mandatory for users, owners, and operators in the province. In addition, NERC has been designated as the “electric reliability organization” under Alberta’s Transportation Regulation, and certain Reliability Standards have been approved in that jurisdiction; others are pending. NERC and NPCC have been recognized as standards-setting bodies by the Régie de l’énergie of Québec, and Québec has the framework in place for Reliability Standards to become mandatory. NERC’s Reliability Standards are also mandatory in Nova Scotia and British Columbia. NERC is working with the other governmental authorities in Canada to achieve equivalent recognition.

# Table of Contents

---

NERC’s Mission .....	2
Table of Contents.....	3
Executive Summary .....	5
Introduction.....	6
Issue Statement .....	6
Chapter 1 – Historical Perspective.....	7
November 9, 1965 .....	7
1965 Northeast Blackout Conclusions .....	8
July 13, 1977 New York Blackout.....	8
1977 New York Blackout Conclusions.....	8
July 2-3, 1996: West Coast Blackout.....	8
July 2-3, 1996: West Coast Blackout Conclusions .....	9
August 10, 1996.....	10
August 10, 1996 Conclusions .....	10
August 14, 2003.....	10
Perry-Ashtabula-Erie West 345 kV Transmission Line Trip.....	11
Homer City – Watercure and Homer – City Stolle Rd 345 kV Transmission Line Trips.....	13
Southeast Michigan Loss of Synchronism.....	15
2003 Northeast Blackout Conclusion.....	16
September 8, 2011 Arizona-California Outages .....	17
Other Efforts from the 2003 Blackout Affecting Relay Response to Stable Power Swings .....	17
Overall Observations from Review of Historical Events .....	17
Chapter 2 – Reliability Issues .....	18
Dependability and Security.....	18
Trade-offs Between Security and Dependability .....	18
Chapter 3 – Reliability Standard Considerations .....	20
Need for a Standard.....	20
Applicability .....	20
Identification of Circuits with Protection Systems Subject to Effects of Power Swings .....	20
Benefits of Defining Applicability for Specific Circuit Characteristics .....	21
Requirements .....	21
Conclusions.....	23
Recommendations.....	24
Appendix A – Overview of Power Swings .....	25
General Characteristics.....	25
Impedance Trajectory.....	25
Appendix B – Protection Systems Attributes Related to Power Swings .....	29
Desired Response .....	29
Response of Distance Protection Schemes.....	29
Power Swing Without Faults.....	29
Appendix C – Overview of Out-of-Step Protection Functions .....	34

---

Power Swing and Out-of-Step Phenomenon .....	34
Basic Phenomenon Using the Two-Source Model .....	34
Representation of Power Swings in the Impedance Plane .....	34
Rate of Change of the Positive-Sequence Impedance .....	35
Out-of-Step Protection Functions .....	36
Power Swing Detection Methods .....	37
Out-of-Step Tripping Function .....	42
Issues Associated With the Concentric or Dual-Blinder Methods .....	45
OOS Relaying Philosophy .....	46
References .....	47
Appendix D – Potential Methods to Demonstrate Security of Protective Relays.....	48
IEEE PSRC WG D6 Method .....	48
Calculation Methods based on the Graphical Analysis Method .....	48
Method 1 .....	49
Method 2 .....	50
Voltage Dip Screening Method .....	53
Discussion of the Results .....	56
Practical Power System Example .....	56
Appendix E – System Protection and Control Subcommittee .....	59
Appendix F – System Analysis and Modeling Subcommittee .....	60
Appendix G – Additional Contributors.....	61

---

*This technical document was approved by the NERC Planning Committee on August 19, 2013.*

# Executive Summary

---

After the August 14, 2003 Northeast Blackout, the Federal Energy Regulatory Commission (FERC) raised concerns regarding performance of transmission line protection systems during power swings. These concerns resulted in issuance of a directive in FERC Order No. 733 for NERC to develop a Reliability Standard that requires the use of protective relay systems that can differentiate between faults and stable power swings and, when necessary, phases out protective relay systems that cannot meet this requirement. In the order, FERC stated that operation of zone 3 and zone 2 relays during the August 2003 blackout contributed to the cascade, and that these relays operated because they were unable to distinguish between a dynamic, but stable power swing and an actual fault. FERC further cited the U.S.-Canada Power System Outage Task Force as identifying dynamic power swings and the resulting system instability as the reason why the cascade spread. While FERC did direct development of a Reliability Standard, FERC also noted that it is not realistic to expect the ERO to develop Reliability Standards that anticipate every conceivable critical operating condition applicable to unknown future configurations for regions with various configurations and operating characteristics. Further, FERC acknowledged that relays cannot be set reliably under extreme multi-contingency conditions covered by the Category D contingencies of the TPL Reliability Standards.

In response to the FERC directive, NERC initiated Project 2010-13.3 – Phase 3 of Relay Loadability: Stable Power Swings to address the issue of protection system performance during power swings. To support this effort, and in response to a request for research from the NERC Standards Committee, the NERC System Protection and Control Subcommittee (SPCS), with support from the System Analysis and Modeling Subcommittee (SAMS), has developed this report to promote understanding of the overall concepts related to the nature of power swings; the effects of power swings on protection system operation; techniques for detecting power swings and the limitations of those techniques; and methods for assessing the impact of power swings on protection system operation.

As part of this assessment the SPCS reviewed six of the most significant system disturbances that have occurred since 1965 and concluded that operation of transmission line protection systems during stable power swings was not causal or contributory to any of these disturbances. Although it might be reasonable, based on statements in the U.S.-Canada Power System Outage Task Force final report, to conclude this was a causal factor on August 14, 2003, subsequent analysis clarifies the line trips that occurred prior to the system becoming dynamically unstable were a result of steady-state relay loadability. The causal factors in these disturbances included weather, equipment failure, relay failure, steady-state relay loadability, vegetation management, situational awareness, and operator training. While tripping on stable swings was not a causal factor, unstable swings caused system separation during several of these disturbances. It is possible that the scope of some events may have been greater without dependable tripping on unstable swings to physically separate portions of the system that lost synchronism.

Based on its review of historical events, consideration of the trade-offs between dependability and security, and recognizing the indirect benefits of implementing the transmission relay loadability standard (PRC-023), the SPCS concludes that a NERC Reliability Standard to address relay performance during stable power swings is not needed, and could result in unintended adverse impacts to Bulk-Power System reliability.

The SPCS came to this conclusion in the course of responding to the Standards Committee request for research. During this process the SPCS evaluated several alternatives for addressing the concerns stated in Order No. 733. While the SPCS recommends that a Reliability Standard is not needed, the SPCS recognizes the directive in FERC Order No. 733 and the Standards Committee request for research to support Project 2010-13.3. Therefore, the SPCS provides recommendations for applicability and requirements that can be used if NERC chooses to develop a standard. The SPCS recommends that if a standard is developed, the most effective and efficient use of industry resources would be to limit applicability to protection systems on circuits where the potential for observing power swings has been demonstrated through system operating studies, transmission planning assessments, event analyses, and other studies, such as UFLS assessments, that have identified locations at which a system separation may occur. The SPCS also proposes, as a starting point for a standard drafting team, criteria to determine the circuits to which the standard should be applicable, as well as methods that entities could use to demonstrate that protection systems on applicable circuits are set appropriately to mitigate the potential for operation during stable power swings.

# Introduction

---

## Issue Statement

After the August 14, 2003 Northeast Blackout, the Federal Energy Regulatory Commission (FERC) raised concerns regarding performance of transmission line protection systems during power swings. These concerns resulted in issuance of a directive in FERC Order No. 733 for NERC to develop a Reliability Standard that requires the use of protective relay systems that can differentiate between faults and stable power swings and, when necessary, phases out protective relay systems that cannot meet this requirement. In the order, FERC stated that operation of zone 3 and zone 2 relays during the August 2003 blackout contributed to the cascade, and that these relays operated because they were unable to distinguish between a dynamic, but stable power swing and an actual fault. FERC further cited the U.S.-Canada Power System Outage Task Force as identifying dynamic power swings and the resulting system instability as the reason why the cascade spread. While FERC did direct development of a Reliability Standard,<sup>2</sup> FERC also noted that it is not realistic to expect the ERO to develop Reliability Standards that anticipate every conceivable critical operating condition applicable to unknown future configurations for regions with various configurations and operating characteristics. Further, FERC acknowledged that relays cannot be set reliably under extreme multi-contingency conditions covered by the Category D contingencies of the TPL Reliability Standards.

In response to the FERC directive, NERC initiated Project 2010-13.3 – Phase 3 of Relay Loadability: Stable Power Swings to address the issue of protection system performance during power swings. To support this effort, and in response to a request for research from the NERC Standards Committee, the NERC System Protection and Control Subcommittee (SPCS), with support from the System Analysis and Modeling Subcommittee (SAMS), has developed this report to promote understanding of the overall concepts related to the nature of power swings; the effects of power swings on protection system operation; techniques for detecting power swings and the limitations of those techniques; and methods for assessing the impact of power swings on protection system operation. The SPCS also proposes, as a starting point for a standard drafting team, criteria to determine the circuits to which the standard should be applicable, as well as methods that entities could use to demonstrate that protection systems on applicable circuits are appropriately set to mitigate the potential for operation during stable power swings.

The SPCS recognizes there are many documents available in the form of textbooks, reports, and transaction papers that provide detailed background on this subject. Therefore, in this report, the SPCS has intentionally limited information on subjects covered elsewhere to an overview of the issues and has provided references that can be consulted for additional detail. The subject matter unique to this report discusses the issues that must be carefully considered, to avoid unintended consequences that may have a negative impact on system reliability, when addressing the concerns stated in Order No. 733.

---

<sup>2</sup> Transmission Relay Loadability Reliability Standard, 130 FERC 61,221, Order No. 733 (2010) (“Order No. 733”) at P.152.

# Chapter 1 – Historical Perspective

---

Transient conditions occur following any system perturbation that upsets the balance of power on the interconnected transmission system, such as changes in load, switching operations, and faults. The resulting transfer of power among generating units is oscillatory and often is referred to as a power swing. The presence of a power swing does not necessarily indicate system instability, and in the vast majority of cases, the resulting power swing is a low-magnitude, well-damped oscillation, and the system moves from one steady-state operating condition to another. In such cases the power swings are of short duration and do not result in the apparent impedance swinging near the operating characteristic of protective relays. Examples of this behavior occurred on August 14, 2003, when there were ten occurrences of transmission lines tripping due to heavy line loading. Each line trip resulted in a low-magnitude, well-damped transient and the transmission system reaching a new stable operating point; however, due to the heavy line loading the apparent impedance associated with the new operating point was within a transmission line relay characteristic.<sup>3</sup> Secure operation of protective relays for these conditions is addressed by NERC Reliability Standards PRC-023 – Transmission Relay Loadability and PRC-025 – Generator Relay Loadability.<sup>4</sup>

Power swings of sufficient magnitude to challenge protection systems can occur during stressed system conditions when large amounts of power are transferred across the system, or during major system disturbances when the system is operating beyond design and operating criteria due to the occurrence of multiple contingencies in a short period of time. During these conditions the angular separation between coherent groups of generators can be significant, increasing the likelihood that a system disturbance will result in higher magnitude power swings that exhibit lower levels of damping. It is advantageous for system reliability that protective relays do not operate to remove equipment from service during stable power swings associated with a disturbance from which the system is capable of recovering. Secure operation of protective relays for these conditions is the subject of a directive in Order No. 733, and is the subject of Project 2010-13.3 – Phase 3 of Relay Loadability: Stable Power Swings.

Under extreme operating conditions a system disturbance may result in an unstable power swing of increasing magnitude or a loss of synchronism between portions of the system. It is advantageous to separate the system under such conditions, and operation of protection systems associated with system instability is beyond the scope of the standard directed in Order No. 733. However, it is important that actions to address operation during stable power swings do not have the unintended consequence of reducing the dependability of protection systems to operate during unstable power swings.

Six major system disturbances are described below, including a discussion of the relationship between power swings and protection system operation and whether operation of protective relays during stable swings was causal or contributory to the disturbance.

## November 9, 1965

The November 1965 blackout, which occurred in the Northeastern United States and Ontario, provides an example of steady-state relay loadability being causal to a major blackout.

The event began when 230 kV transmission lines from a hydro generating facility were heavily loaded due to high demand of power from a major load center just north of the hydro generating facility. Heavy power transfers prior to the disturbance resulted from the load center area being hit by cold weather, coupled with an outage of a nearby steam plant.

The transmission line protection included zone 3 backup relays, which were set to operate at a power level well below the capacity of the lines. The reason for the setting below the line capacity was to detect faults beyond the next switching point from the generating plant. From the time the relays were initially set, the settings remained unchanged while the loads on the lines steadily increased.

Under this circumstance a plant operator, who was apparently unaware of the installed relay setting limitation, attempted to increase power transfer on one of the 230 kV lines. As a result, the load impedance entered the operating characteristics

---

<sup>3</sup> Informational Filing of the North American Electric Reliability Corporations in Response to Order 733-A on Rehearing, Clarification, and Request for an Extension of Time, Docket No. RM08-13-000 (July 21, 2011) (“NERC Informational Filing”), at p. 4.

<sup>4</sup> PRC-025-1 is presently in development under Project 2010-13.2 Phase 2 of Relay Loadability: Generation.

of the zone 3 line backup relay. The relay operated and tripped the line breaker. Subsequently, the rest of the lines became overloaded. As it happened, each line breaker was tripped by the zone 3 line backup relay one-by-one over a period of approximately 2.7 seconds.

When all five lines tripped, the hydro generators accelerated rapidly due to the initial reduction of connected electrical load. The resulting drop in generation at this hydro plant and the rapid build-up of generation in the interconnected system resulted in large power swings that resulted in a loss of synchronism between two portions of the system. This incident initiated a sequence of events across the power system of the northeastern seaboard. The resulting massive outage lasted from a few minutes in some locations to more than a few days in others and encompassed 80,000 square miles, directly affecting an estimated 30 million people in the United States and Canada. This was the largest recorded blackout in history at the time.

### **1965 Northeast Blackout Conclusions**

Relays tripping due to stable power swings were not contributory or causal factors in this blackout. Relays applied to 230 kV transmission lines tripping due to load and a lack of operator knowledge of relay loadability limitations caused and contributed to this outage. The Bulk-Power System is protected against a recurrence of this type of event by the requirements in NERC Reliability Standard PRC-023-2.

### **July 13, 1977 New York Blackout**

This disturbance resulted in the loss of 6,000 MW of load and affected 9 million people in New York City. Outages lasted for up to 26 hours. A series of events triggering the separation of the Consolidated Edison system from neighboring systems and its subsequent collapse began when two 345 kV lines on a common tower in northern Westchester County were struck by lightning and tripped out. Over the next hour, despite Consolidated Edison (Con Edison) dispatcher actions, the system electrically separated from surrounding systems and collapsed. With the loss of imports, generation in New York City was not sufficient to serve the load in the city.

Major causal factors were:

- Two 345 kV lines experienced a phase B-to-ground fault caused by a lightning strike.
- A nuclear generating unit was isolated due to the line trips and tripped due to load rejection. Loss of the ring bus also resulted in the loss of another 345 kV line.
- About 18.5 minutes later, two more 345 kV lines tripped due to lightning. One automatically reclosed and one failed to reclose isolating the last Con Edison interconnection to the northwest.
- The resulting surge of power caused another line to trip due to a relay with a bent contact.
- About 23 minutes later, a 345 kV line sagged into a tree and tripped out. Within a minute a 345/138 kV transformer overloaded and tripped.
- The tap-changing mechanism on a phase-shifting transformer carrying 1150 MW failed, causing the loss of the phase-shifting transformer.

The two remaining 138 kV ties to Con Edison tripped on overload isolating the system. Insufficient generation in the isolated system caused the Con Edison island to collapse.

### **1977 New York Blackout Conclusions**

Relays tripping due to stable power swings were not contributory or causal factors in this blackout. A series of line and transformer trips due to weather, equipment failure, relay failure, and overloads caused and contributed to this outage.

### **July 2-3, 1996: West Coast Blackout**

On July 2, 1996 portions of the Western Interconnection were unknowingly operated in an insecure state. The July 2 disturbance was initiated at 14:24 MST by a line-to-ground fault on the Jim Bridger – Kinport 345 kV line due to a flashover to a tree. A protective relay on the Jim Bridger – Goshen 345 kV line misoperated due to a malfunctioning local delay timer, de-energizing the line and initiating a remedial action scheme which tripped two units at the Jim Bridger generating station. The initial line fault, subsequent relay misoperation, inadequate voltage support, and unanticipated system conditions led

to cascading outages causing interruption of service to several million customers and the formation of five system islands. Customer outages affected 11,850 MW of load in the western United States and Canada, and Baja California Norte in Mexico. Outages lasted from a few minutes to several hours.

Major causal factors were:

- A 345 kV line sagged due to high temperatures and loading causing a flashover to a tree within the right-of-way and the line was de-energized properly. A second line simultaneously tripped incorrectly due to a protective relay malfunction.
- Output of a major generating plant was reduced by design due to the two line trips. Two of four generating units at that plant were correctly tripped via a Remedial Action Scheme. The trips of these units caused frequency in the Western Interconnection to decline.
- About 2 seconds later, the Round Up – LaGrand 230 kV line tripped via a failed zone 3 relay.
- About 13 seconds later a couple of small units tripped via field excitation overcurrent.
- About 23 seconds later, the Anaconda – Amps (Mill Point) 230 kV line tripped via a zone 3 relay due to high line loads.
- Over the next 12 seconds, numerous lines tripped due to high loads, low voltage at line terminals, or via planned operation of out-of-step relaying. Low frequency conditions existed in some areas during many of these trips.
- The Western Interconnection separated into five planned islands designed to minimize customer outages and restoration times. The separation occurred mostly by line relay operation with three exceptions: Utah was separated from Idaho by the Treasureton Separation Scheme, Southern Utah separated by out-of-step relaying, and Nevada separated from SCE by out-of-step relaying.

On July 3, 1996, at 2:03 p.m. MST a similar chain to the July 2, 1996 events began. A line-to-ground fault occurred on the Jim Bridger – Kinport 345 kV line due to a flashover to a tree. A protective relay on the Jim Bridger – Goshen 345 kV line misoperated due to a malfunctioning local delay timer, de-energizing the line and initiating a remedial action scheme (RAS) which tripped two units at the Jim Bridger generating station. Scheduled power limits were reduced on the California – Oregon Intertie (COI) north-to-south pending the results of technical studies being conducted to analyze the disturbance of the previous day. The voltage in the Boise area declined to about 205 kV over a three minute period. The area system dispatcher manually shed 600 MW of load over the next two minutes to arrest further voltage decline in the Boise area, containing the disturbance and returning the system voltage to normal 230 kV levels. All customer load was restored within 60 minutes.

The Western Systems Coordinating Council Disturbance Report For the Power System Outages that Occurred on the Western Interconnection on July 2, 1996 and July 3, 1996 approved by the WSCC Operations Committee on September 19, 1996 includes numerous recommendations one of which is the following:

- The WSCC Operations Committee shall oversee a review of out-of-step tripping and out-of-step blocking within the WSCC region to evaluate adequacy. This includes:
  1. Out-of-step relays that operated;
  2. Out-of-step relays that did not operate but should have; and
  3. Out-of step conditions that caused operation of impedance relays.
- Work by C.W. Taylor<sup>5</sup> following the disturbance report recommended the review of the use of zone 3 relays which was a contributing factor to the severity of this disturbance.

### **July 2-3, 1996: West Coast Blackout Conclusions**

Relays tripping due to stable power swings was not causal or contributory to the July 2-3 West Coast Blackout. Out-of-step relaying did play a role as a safety net designed to limit the extent and duration of customer outages and restoration times.

---

<sup>5</sup> Taylor, C.W., Erickson, Dennis C., IEEE Computer Applications in Power, Vol. 10, Issue 1, 1997.



Unstudied system conditions including unexpectedly high transfer conditions coupled with a series of line trips due to vegetation intrusion, relay malfunctions, and relay loadability issues caused and contributed to this outage.

## August 10, 1996

At 15:48 PST on August 10, 1996, a major system disturbance separated the Western Interconnection into four islands, interrupting service to 7.5 million customers, with total load loss of 30,390 MW. The interruption period ranged from several minutes to nearly nine hours.

The pre-event system conditions in the Western Interconnection were characterized by high north-to-south flows from Canada to California. At 15:42:37, the Allston – Keeler 500 kV line sagged close to a tree and flashed over, additionally forcing the Pearl – Keeler 500 kV line out of service due to 500/230 kV transformer outage and breaker replacement work at Keeler. The line was tripped following unsuccessful single-pole reclosure. The 500 kV line outage caused overloading and eventual tripping of several underlying 115 kV and 230 kV lines, also in part due to reduced clearances. System voltages sagged partly because several plants were operated in var regulation mode. At 15:47:37, sequential tripping of all units at McNary began due to excitation protection malfunctions at high field voltage as units responded to reduced system voltages.

Bonneville Power Administration (BPA) automatic generation control (AGC) further aggravated the situation by increasing generation in the upper Columbia area (Grand Coulee and Chief Joseph) to restore the generation-load imbalance following McNary tripping. As a result of the above outages and shift of generation northward, sustained power oscillations developed across the interconnection. The magnitude of power and voltage oscillations further increased, as Pacific HVdc Intertie controls started participating in the oscillation. These oscillations were a major factor leading to the separation of the California – Oregon Intertie and subsequent islanding of the Western Interconnection system.

Ultimately, the magnitude of voltage and current oscillations caused opening of two COI 500 kV lines (Malin – Round Mountain #1 and #2 500 kV lines) by switch-onto-fault relay logic. The third COI 500 kV line tripped 170 ms later. Some of the power that was flowing into northern California surged east and then south through Idaho, Utah, Colorado, Arizona, New Mexico, Nevada, and southern California. Numerous transmission lines in this path subsequently tripped due to out-of-step conditions and low system voltage. Because at that time the Northeast – Southeast separation scheme was kept out of service when all COI lines were in operation, the Western Interconnection experienced uncontrolled islanding. Fifteen large thermal and nuclear plants in California and the desert southwest failed to ride through the disturbance and tripped after the system islanding, thereby delaying the system restoration.

## August 10, 1996 Conclusions

Relays tripping due to stable power swings were not causal or contributory to the August 10th West Coast Blackout. System operation was unknowingly in an insecure state prior to the outage of the Keeler-Allston 500 kV line due to reduced clearances resulting from a season of rapid tree growth and stagnant atmospheric conditions. Outage of the Keeler-Allston 500 kV line precipitated the overloading and tripping of underlying parallel 230 kV and 115 kV lines, causing undesirable tripping of key hydro units, voltage drops, and subsequent increasing of power oscillations, all of which led to tripping of the COI and other major transmission lines separating the Western Interconnection into four islands. The result was widespread uncontrolled outage of generation and the interruption of service to approximately 7.5 million customers.

## August 14, 2003

Similar to a number of the disturbances discussed above, the disturbance on August 14, 2003 concluded with line trips during power swings that were preceded by many outages due to other causes. The progression of cascading outages on August 14, 2003 was initially caused by lines contacting underlying vegetation (the basis for Blackout Recommendation 4<sup>6</sup> and FAC-003), followed by a series of lines tripping due to steady-state relay loadability issues (the basis for Blackout Recommendation 8a<sup>7</sup> and PRC-023). After the system was severely weakened by these outages, line trips occurred in response to power swings.

---

<sup>6</sup> Approved by the NERC Approved by the Board of Trustees, February 10, 2004.

<sup>7</sup> Ibid.

In the days and hours preceding the early afternoon of August 14 the power system experienced a number of generation and transmission outages that resulted in increased transfers of power between portions of the system. During the early afternoon a number of lines tripped, first due to contact with underlying vegetation and then due to load encroaching into the operating characteristics of phase distance relays. The events occurred over a period of hours, with sufficient time between events for the system to find a new steady-state condition after each event.

In Order No. 733 and Order No. 733-A FERC discussed tripping of fourteen transmission lines to support the directive pertaining to conditions in which relays misoperate due to stable power swings. FERC cited the Blackout Report<sup>8</sup>, stating the system did not become dynamically unstable until at least the Thetford – Jewell 345 kV line tripped at 16:10:38 EDT. FERC noted that up until this point, with each dynamic, but stable, power swing, the transmission system recovered and appeared to stabilize. However, as the power swings and oscillations increased in magnitude, zone 3, zone 2, and other relays on fourteen key transmission lines reacted as though there was a fault in their protective zone even though there was no fault. These relays were not able to differentiate the levels of currents and voltages that the relays measured, because of their settings, and consequently operated unnecessarily.<sup>9</sup> The Commission’s directive pertains to conditions in which relays misoperate due to stable power swings that were identified as propagating the cascade during the August 2003 Blackout.<sup>10</sup>

NERC subsequently clarified that the fourteen lines did not trip due to stable power swings; ten of these lines tripped in response to the steady-state loadability issue addressed by Reliability Standard PRC-023, while the last four lines tripped in response to dynamic instability of the power system. Although the Blackout Report states that the system did not become dynamically unstable until at least after the Thetford – Jewell 345 kV transmission line trip<sup>11</sup>, subsequent analysis indicates that the system became dynamically unstable following tripping of the Argenta – Battle Creek and Argenta – Tompkins 345 kV transmission lines, about two seconds earlier than stated in the Blackout Report. The operations not associated with faults, up to and including the initial trips of Argenta – Battle Creek and Argenta – Tompkins lines, are associated with the steady-state loadability issue addressed by Reliability Standard PRC-023.<sup>12</sup>

As the cascade accelerated, 140 discrete events occurred from 16:05:50 to 16:36. The last transmission lines to trip as result of relay loadability concerns were the Argenta –Battle Creek and Argenta – Tompkins 345 kV transmission lines in southern Michigan at 16:10:36. Upon tripping of these lines the disturbance entered into a dynamic phase characterized by significant power swings resulting in electrical separation of portions of the power system. Within the time delay associated with high-speed reclosing (500 ms) the angles between the terminals of these lines reached 80 degrees and 120 degrees respectively prior to unsuccessful high-speed reclosing of these lines.

The next line trips in the sequence of events occurred as a result of power swings. These trips occurred on the Thetford – Jewell and Hampton – Pontiac 345 kV transmission lines north of Detroit at 16:10:38. These lines tripped as the result of apparent impedance trajectories passing through the directional comparison trip relay characteristics at both terminals of each line. All subsequent line trips occurred as the result of power swings. All but two of these trips occurred during unstable power swings. A few of the events relevant to this subject are discussed below.

### **Perry-Ashtabula-Erie West 345 kV Transmission Line Trip**

The Perry – Ashtabula – Erie West 345 kV line is a three-terminal line between Perry substation in northeast Ohio and Erie West substation in northwest Pennsylvania, with a 345-138 kV autotransformer tapped at the Ashtabula substation in northeast Ohio. This transmission line trip is interesting because the line tripped at the Perry terminal by its zone 3 relay. Typically zone 3 line trips are associated with relay loadability issues, as the zone 3 time delay typically is set longer than the time it would take for a power swing to traverse the relay trip characteristic. The fact that the protection system trip was initiated by the zone 3 relay raises questions as to whether the power swing was stable or unstable. The rate-of-change of an apparent impedance trajectory typically is used as a discriminant to identify unstable swings, based on the assumption that higher rates-of-change are associated with unstable swings. In this case the speed of the apparent impedance

---

<sup>8</sup> *U.S.-Canada Power System Outage Task Force, Final Report on the August 14, 2003 Blackout in the United States and Canada: Causes and Recommendations* (Apr. 2004) (“Blackout Report”).

<sup>9</sup> *Transmission Relay Loadability Reliability Standard*, 134 FERC 61,127, Order No. 733-A (2011) (“Order No. 733-A”). Order No. 733-A at P.110.

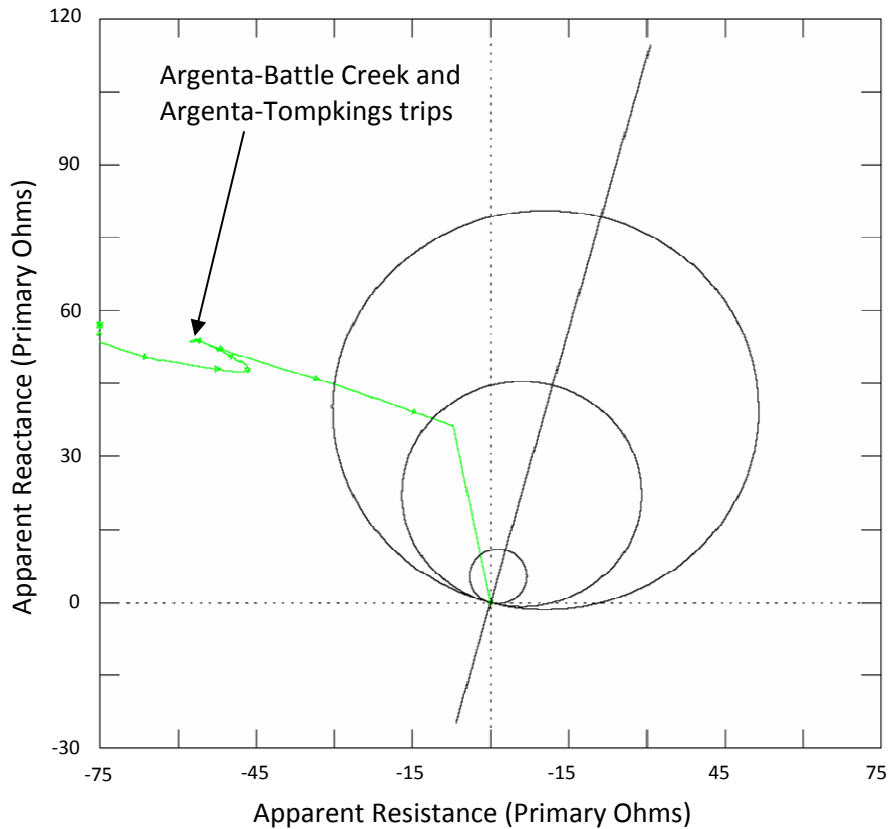
<sup>10</sup> *Id.*, P.111.

<sup>11</sup> Blackout Report at p. 82.

<sup>12</sup> NERC Informational Filing, at p. 6.

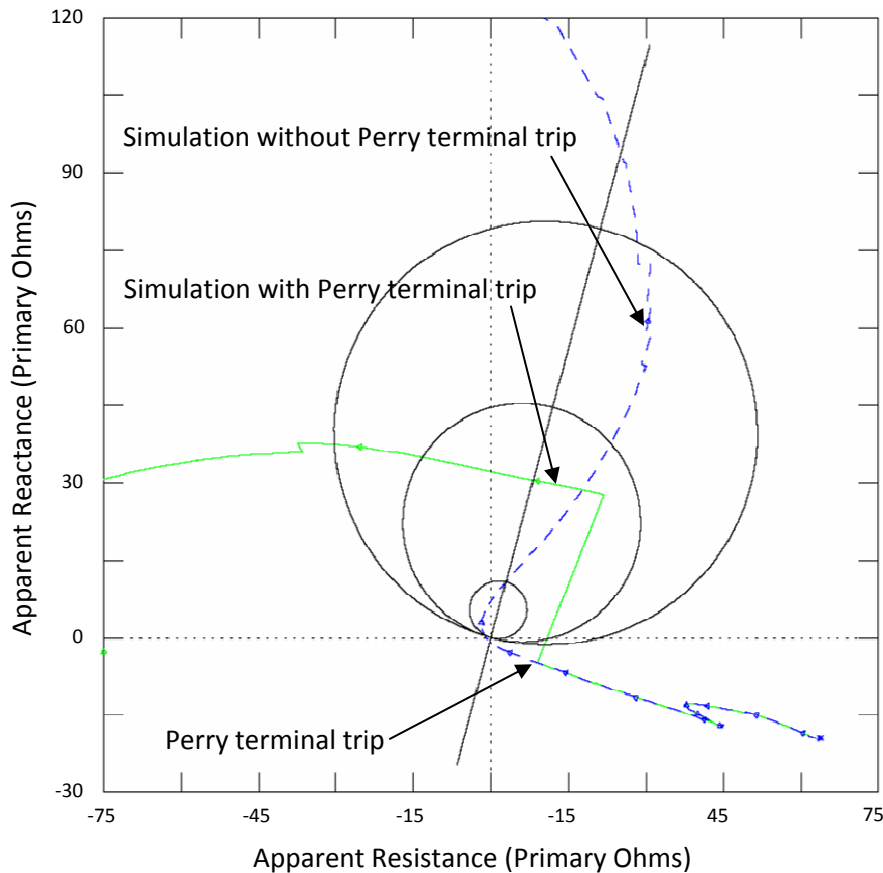
trajectory was relatively slow, as it would need to be to remain within the zone 3 characteristic long enough to initiate a trip. Dynamic simulation of the event confirmed that while this swing was slow to develop, had the line not been tripped by its zone 3 relay the swing eventually would have entered the zone 1 relay characteristic at the Erie West terminal followed by a loss of synchronism condition.

Figure 1 presents the simulated apparent impedance trajectory observed from the Perry line terminal. This figure shows that the apparent impedance swing was moving away from the relay characteristic up to the time of the Argenta – Battle Creek and Argenta – Tompkins 345 kV line trips, at which time the trajectory reversed direction and entered the zone 3 relay characteristic from the second quadrant. The apparent impedance remained in the relay characteristic long enough to initiate a zone 3 trip.



**Figure 1: Apparent Impedance Trajectory for Perry – Ashtabula 345 kV Line on August 14, 2003**

Figure 2 presents the simulated apparent impedance observed from the Erie West terminal. The first (green) apparent impedance trajectory is the simulated trajectory with the zone 3 trip at Perry simulated. With the 345 kV path from Erie West to Perry interrupted, the decreased flow on the line from Erie West into the 345-138 kV transformer at Ashtabula resulted in the apparent impedance moving to a new trajectory further from the Erie West terminal. The apparent impedance trajectory was resimulated with tripping of the Perry terminal blocked. The second (blue) trajectory demonstrates that the next swing would have been unstable, passing through the zone 1 relay characteristic and eventually crossing the system impedance indicative of a loss of synchronism condition with the system angle increasing beyond 180 degrees.



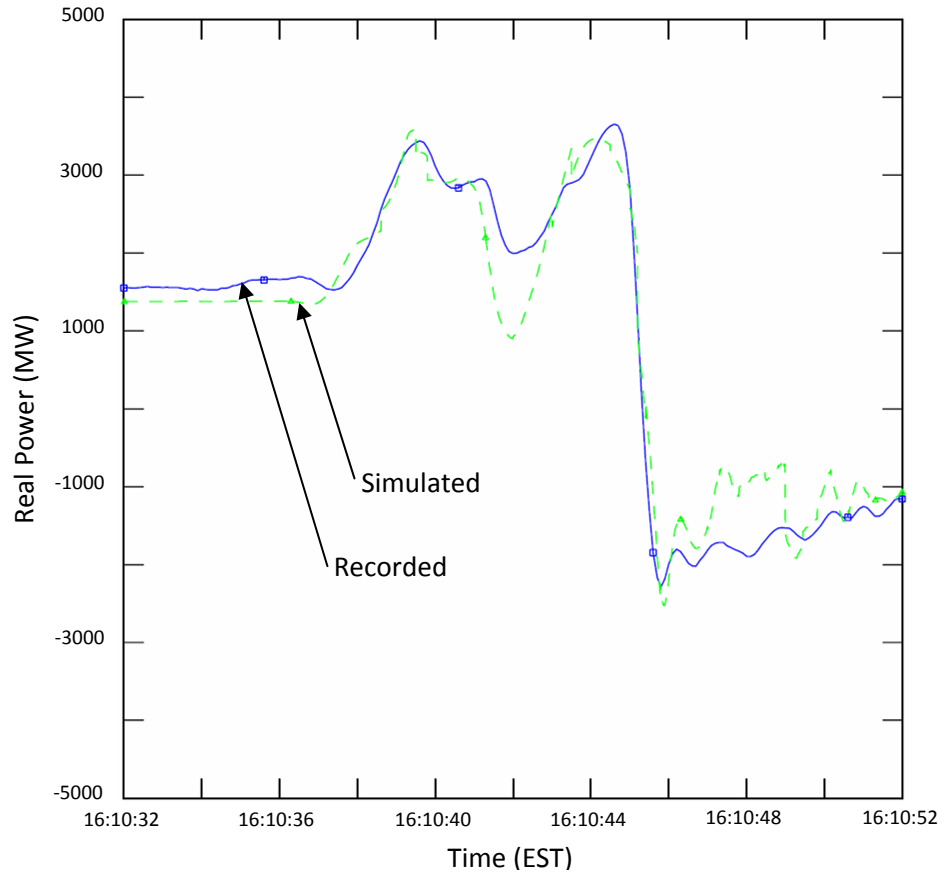
**Figure 2: Apparent Impedance Trajectory for Erie West – Ashtabula 345 kV Line on August 14, 2003**

In addition to the Perry – Ashtabula – Erie West trip demonstrating that the apparent impedance trajectory of a power swing can result in a time delayed trip, it also demonstrates that for severely stressed system conditions with a rapid succession of events exciting multiple dynamic modes, the resulting apparent impedance trajectories may vary significantly from the traditional textbook trajectories that are based on two-machine system models. This points to the difficulty of establishing standardized applications to address out-of-step conditions that are both secure and dependable for all possible system conditions.

### **Homer City – Watercure and Homer – City Stolle Rd 345 kV Transmission Line Trips**

These two transmission lines connect the Homer City generating plant in central Pennsylvania to the Watercure and Stolle Rd substations in western New York. As the power swing traveled across the system, this was the next place the swing was observable: along the interface between New York and the PJM Interconnection. These two transmission lines were tripped by their respective zone 1 relays at Homer City.

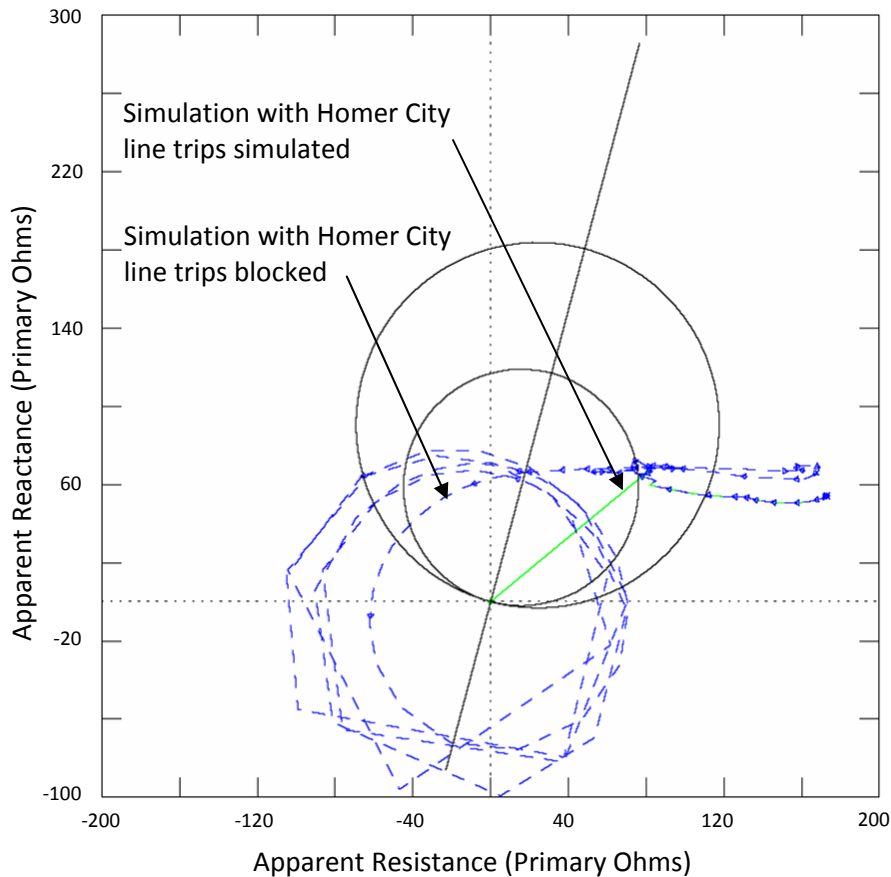
The recorded and simulated powerflow across this interface are presented in Figure 3 below. Following the separation in southern Michigan, two swings occurred between the New York and PJM systems. The first swing occurred at approximately 16:10:39.5 corresponding to tripping of the Homer City – Watercure and Homer City – Stolle Road 345 kV transmission lines. The second swing occurred approximately 4 seconds later corresponding with the New York-PJM separation completed by the Branchburg – Ramapo 500 kV line trip.



**Figure 3: PJM-New York Interface Flow on August 14, 2003**

Since only two transmission lines between the PJM Interconnection and the New York system tripped during the first swing, it raises the question as to whether these lines tripped on a stable swing, and if so, would these two portions of the system have remained synchronized if all lines comprising the PJM-New York interface had been in service at the time of the second power swing.

The dynamic simulation was run twice for this time-frame: once with the Homer City line trips modeled and once with the Homer City line trips blocked. Figure 4 presents the apparent impedance for the Homer City terminal of the Homer City – Watercure transmission line for each simulation.



**Figure 4: Apparent Impedance Trajectory for Homer City – Watercure 345 kV Line on August 14, 2003**

The first (green) apparent impedance trajectory shows the apparent impedance entering the zone 1 relay characteristic and the line tripping (represented in the plot by the apparent impedance “jumping” to the origin). The second (blue) trajectory representing the simulation with line tripping blocked demonstrates that the first swing was stable with the trajectory turning around just after entering the zone 1 relay characteristic. On the next swing, occurring about 4 seconds later, it is clear that the swing is unstable and the apparent impedance exits the relay characteristic through the second quadrant. The plot shows that with tripping of these lines blocked that these two portions of the system lose synchronism and slip poles as long as the two systems remain physically connected.

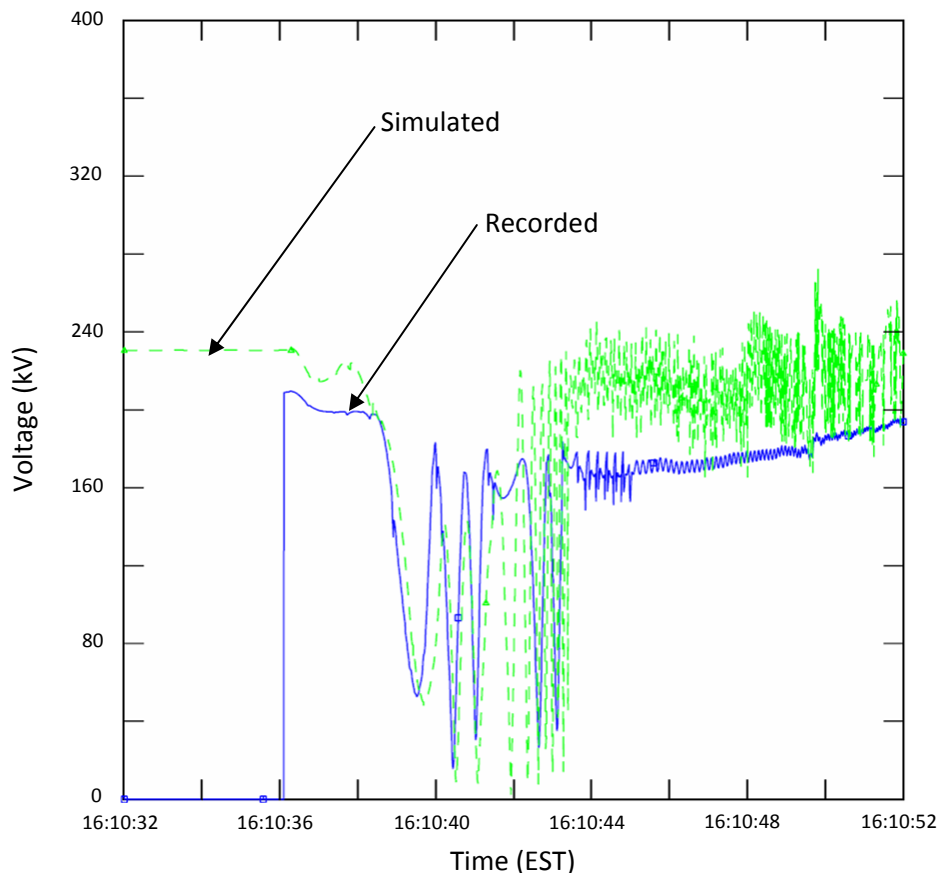
The blackout investigation team concluded that while these two lines did trip on a stable swing, these trips were not contributory to the blackout since the lines would have tripped four seconds later on the next swing, which was unstable. The blackout investigation team further concluded that since the protection systems on these lines did demonstrate the potential for tripping on stable swings, the Transmission Owners should investigate changes that could be made to improve the security of protection system operation on the Homer City 345 kV transmission lines to Watercure and Stolle Road. The Transmission Owners have performed extensive testing of the out-of-step tripping and power swing blocking functions on new protection systems using simulated power swings from the August 14, 2003 blackout investigation. This testing has identified susceptibility of some protection systems to misoperate, which highlights the difficulty of providing both dependable and secure operation for every conceivable critical operating condition, particularly when considering conditions well beyond the N-1 or N-2 conditions for which power systems typically are designed and when considering more complex swings with multiple modes and time-varying voltage..

### **Southeast Michigan Loss of Synchronism**

Following the Michigan East-West separation and Perry – Ashtabula – Erie West trip, the power flow from Ontario to Michigan and from Michigan to Ohio increased. During this time voltages in southeast Michigan began to drop rapidly. In

response to the decreased voltage and corresponding drop in load, the generating units south of Detroit began to accelerate rapidly and slipped two poles.

The system conditions associated with the generating units slipping two poles resulted in turbine trips on many of these generating units. As mechanical power to the turbines was reduced, the generators slowed down and frequency in southern Detroit began to decline. Many of these generating units rely on a reverse power relay to trip the generator after the turbine is tripped and mechanical power is reduced. Since these units lost synchronism with the rest of the system the electrical power on these units changed direction with each pole slip and the reverse power condition was not sustained long enough for the reverse power relay to trip the unit. As a result, the southeast Michigan portion of the system operated asynchronously while connected through the two 120 kV lines. Figure 5 illustrates the effect of the out-of-step conditions on system voltage. The first trace (blue) is the recorded voltage at the Keith substation in southern Ontario which shows five voltage swings of approximately 0.8 per unit corresponding to each pole slip until the mechanical input to the turbines was tripped. This plot illustrates the voltage stress on equipment when two systems operate asynchronously without dependable tripping for out-of-step conditions. Generating units may experience corresponding shaft stress during each pole slip.



**Figure 5: Keith Voltage During Southern Michigan Loss-of-Synchronism**

### 2003 Northeast Blackout Conclusion

Relays tripping due to stable power swings were not contributory or causal factors in this blackout. Although it is reasonable to conclude this was a causal factor based on statements in the Blackout Report and cited in FERC Order No. 733 and subsequent FERC orders, subsequent analysis cited in the NERC Informational filing clarifies that only two 345 kV lines tripped in response to stable power swings, and these two trips occurred well into the cascading portion of the disturbance. Simulations confirm that if the relays had not tripped these lines on the stable power swing, the relays would have tripped on an unstable swing a few seconds later, with no significant difference in the subsequent events or the magnitude and duration of the resulting outages. Recorded and simulated data also demonstrate the adverse effect of not having dependable tripping for unstable power swings.

## **September 8, 2011 Arizona-California Outages**

This disturbance is well documented in the April 2012 FERC/NERC Staff Report on the September 8, 2011 Blackout, available on the NERC website. Twenty seven findings and recommendations were made in this report. Relays tripping due to stable power swings were not cited in any of the recommendations from the NERC/FERC report. Relays tripping due to stable power swings were not contributory or causal factors in this blackout.

## **Other Efforts from the 2003 Blackout Affecting Relay Response to Stable Power Swings**

The August 14, 2003 northeast blackout spawned the effort that raised the bar on relay loadability. Efforts included the “Zone 3” and “Beyond Zone 3” relays reviews that preceded development of the PRC-023 Transmission Relay Loadability standard. The SPCTF report, *Protection System Review Program – Beyond Zone 3*, dated December 7, 2006 identified that 22 percent of the 11,499 EHV relays reviewed required changes to meet the NERC Recommendation 8a criterion or a Technical Exception (equivalent to the criteria under Requirement R1 of PRC-023-2). Methods used to attain the greater loadability typically included limiting relay reaches or changing relay characteristic shapes or both. These relay changes affected relays with the largest distance zones susceptible to tripping on stable power swings such as the Perry – Ashtabula – Erie West zone 3 trip discussed above. In many cases these relay changes also affected distance zones that trip high-speed such as zone 2 functions that are part of communication-assisted protection systems, and in some cases even zone 1 relays that trip without intentional time delay. While it is not possible to quantify the extent to which these modifications improved security against tripping for stable power swings, reducing the resistive reach of phase distance protection functions does increase the power system angular separation necessary to enter the relay characteristic. Thus, these changes increased security throughout North America for relays susceptible to tripping on stable power swings.

## **Overall Observations from Review of Historical Events**

Relays tripping on stable power swings were not causal or contributory in any of the historical events reviewed. Causal factors in the events included lines sagging into trees, lines tripping via relay action due to high loads, lines tripping due to relay malfunctions, and other causes. These causes have been addressed in several NERC Reliability Standards.

Relays tripping on unstable swings occurred in several of the historical events reviewed. The tripping was not causal or contributory as tripping on unstable swings occurs after the system has reached the point of instability, cascading, or uncontrolled separation. However, it is possible that the scope of some events may have been greater without dependable tripping on unstable swings to physically separate portions of the system that lost synchronism.



## Chapter 2 – Reliability Issues

---

### Dependability and Security

When considering power swings, both facets of protection system reliability are important to consider. To support power system reliability it is desirable that protection systems are secure to prevent undesired operation during stable power swings. It also is desirable to provide dependable means to separate the system in the event of an unstable power swing.

Protection system security during stable swings is important to maintaining reliable power system operation. Unnecessary tripping of transmission lines during stable power swings may lead to cascade tripping due to increased loading on parallel circuits or may lead directly to power system instability by increasing the apparent impedance between two portions of the system.

Ensuring that dependable means are available to separate portions of the system that have lost synchronism is essential to maintaining reliable power system operation. Failing to physically separate portions of the system that have lost synchronism will result in adverse impacts due to the system slipping poles, resulting in significant voltage and power flow deviations occurring at the system slip frequency. Near the electrical center of the power swing the voltage deviations will have amplitude of nearly 1 per unit, stressing equipment insulation. Rapid changes in power flow also stress equipment, in particular rotating machines that are participating in the swings.

### Trade-offs Between Security and Dependability

Secure and dependable operation of protection systems are both important to power system reliability. While methods for discriminating between stable and unstable power swings have improved over time, ensuring both secure and dependable operation for all possible system events remains a challenge. Testing out-of-step functions using simulated power system swings from the August 14, 2003 blackout investigation has identified susceptibility of some protection systems to misoperate, which highlights the difficulty of providing both dependable and secure operation for every conceivable critical operating condition, particularly when considering conditions well beyond the N-1 or N-2 conditions for which power systems typically are designed and when considering more complex swings with multiple modes and time-varying voltage.

While the directive in Order No. 733 is focused on protective relays operating unnecessarily due to stable power swings, it is important that focusing on this aspect of security does not occur to the detriment of system reliability by producing the unintended consequence of decreasing ability to dependably identify unstable swings and separate portions of the system that have lost synchronism.

It certainly is possible to provide transmission line protection that can discriminate between fault and power swing conditions. Current-based protection systems such as current differential or phase comparison can be utilized to provide a high degree of security against operation for stable power swings. However, application of such protection systems in locations where the system may be prone to unstable power swings does not provide a dependable means of separating portions of the system that lose synchronism. In such cases it would be necessary to install out-of-step protection to initiate system separation, which reintroduces the need to discriminate between stable and unstable power swings. Installing current-based protection systems does not remove the need to install impedance-based back up protection, which reintroduces the need to discriminate between stable and unstable power swings.

Recognizing that no one protection system design can provide security and dependability for all possible power swings under all possible system conditions, two questions must be considered: (1) for what conditions must protection systems operate reliably, and (2) under conditions for which reliable operation cannot be assured, should protection system design err on the side of security or dependability. The trade-offs between secure and dependable operation in response to system faults are discussed much more frequently than the trade-offs in response to power swings; however, there are similarities when comparing fault and power swing conditions. In both cases, a lack of dependability is more likely to result in an undesirable outcome. For a fault condition, a failure to trip will result in increased equipment damage and acceleration of rotating machines that may result in system instability. For an unstable power swing, a failure to trip will result in portions of the system slipping poles against each other and resultant increased equipment stress and an increased probability of system collapse.

By comparison, tripping an additional circuit in response to a fault may lead to unacceptable system performance; however, the potential for equipment damage or instability is less than for a failure to trip, particularly in highly networked systems. In theory tripping a circuit for a stable power swing may lead to cascade tripping of power system circuits; however, analysis of historical events supports that the probability of undesirable system performance is less than for a failure to trip for an unstable swing.

Given the relative risks associated with a lack of dependable operation for unstable power swings and the lack of secure operation for stable swings, over-emphasizing secure operation for stable powers swings could be detrimental to Bulk-Power System reliability. It therefore is preferable to emphasize dependability over security when it is not possible to ensure both for all possible system conditions.

## Chapter 3 – Reliability Standard Considerations

---

### Need for a Standard

Based on its review of historical events, consideration of the trade-offs between dependability and security, and recognizing the indirect benefits of implementing the transmission relay loadability standard (PRC-023), the SPCS concludes that a NERC Reliability Standard to address relay performance during stable swings is not needed, and could result in unintended adverse impacts to Bulk-Power System reliability.

In the course of coming to this conclusion, however, the SPCS has developed recommendations for implementing a standard. Given the directive in FERC Order No. 733 and the Standards Committee request for research to support Project 2010-13.3, the SPCS recommends that if a standard is developed it should include the following applicability and requirements.

### Applicability

Two options exist for developing requirements for secure operation of protection systems during power swings: (i) develop requirements applicable to protection systems on all circuits, or (ii) identify the circuits on which a power swing may affect protection system operation and develop requirements applicable to protection systems on those specific circuits. The effort to assess every protection system to assure it will not operate during stable power swings would be significant. An equally effective and more efficient approach would be to identify the types of circuits on which protection systems would be challenged by power swings, and limit the applicability of a new standard to these circuits.

During development of this report the SPCS explored the possibility of recommending a standard applicable to all circuits and requiring that entities verify for each circuit that either a power swing will not pass through the circuit or that the protection system on the circuit would not operate for a stable power swing. The SPCS investigated several different approaches including the analytical assessment and system study approaches described in Appendix D. Analysis of the various approaches indicated that applying one or more of these approaches to each circuit would be a significant effort with varying results that are dependent on the system topology and the assumptions specified for the analysis. Extreme system topologies are often present during actual relay trips during power swings. These topologies would be very difficult to anticipate in a study. The historical evidence supports taking a more efficient approach to limit burden on responsible entities given the limited role that undesired tripping in response to stable power swings has played in major disturbances. Such an approach is consistent with taking a risk-based approach to Reliability Standards by focusing the applicability to circuits on which protection systems are most likely to be affected during power swings.

This section recommends an approach for identifying those power system circuits on which protection systems are susceptible to operation for stable power swings. Although past system disturbances do not provide specific input on which circuits are most at risk, past disturbances demonstrate it is not necessary for a Reliability Standard to apply to all lines. In the absence of direct input from past disturbances, the SPCS believes it is reasonable to recommend an approach that uses information from existing planning and operating studies and experience, and physical attributes of power systems. This approach provides the opportunity to effectively identify circuits of concern without requiring extensive, and in many cases duplicative, studies. The recommended approach is an effective and efficient manner that can be used to limit the number of circuits for which entities are required to evaluate and provide a basis for protection system response during power swings.

### Identification of Circuits with Protection Systems Subject to Effects of Power Swings

Power system swings, stable or unstable, are caused by the relative motion of generators with respect to each other. These power swings manifest themselves as swings in the apparent impedance “seen” by protective relays due to the variations in voltages and currents which occur during these swings. Power swings are classified as local mode or inter-area mode. Local mode oscillations are characterized by units at a generating station swinging with respect to the rest of the system. This is in contrast to inter-area mode oscillations, where a coherent group<sup>13</sup> of generating stations in one part of the system is swinging against another coherent group of generators in a different part of the system.

---

<sup>13</sup> In this context, the generators in a coherent group exhibit similar waveforms for their rotor-angle response to a system disturbance.

The electrical center of a local mode swing tends to remain relatively close to the generating station that is causing the swing. The electrical center of an inter-area mode oscillation will occur between the two coherent groups of generators. Therefore, it can be concluded that stable power swings are most likely to challenge protective relays on lines terminating at generating stations or on lines between coherent groups of generators. This is a useful filter in identifying transmission lines on which protective relays should be subject to the Reliability Standard.

The electrical center of a power swing is determined by physical characteristics of the system. The electrical center may vary depending on the dispatch of generators and status of transmission equipment making it difficult to assure that all possible power swings are identified. This is particularly true when considering power swings that may occur during major system disturbances after a number of circuits have tripped. However, it is possible to identify the most likely locations of electrical centers of power swings and focus attention on protections systems applied on the circuits where the electrical centers exist. In the case of local mode oscillations the electrical center is most likely to occur in the generator step-up (GSU) transformer or on a transmission line connected to the bus on the high-side of the GSU transformer. In the case of an inter-area oscillation the electrical center is more difficult to predict; however, the electrical center already will have been identified if any planning or operating studies have identified the need to apply a System Operating Limit (SOL) based on stability constraints, or if other studies or event analyses have identified the potential for tripping during a system disturbance that includes power swings.

The standard drafting team should consider the following criteria in establishing the applicability of the Reliability Standard to limit applicability to only those transmission lines on which protective relays are most likely to be challenged during stable power swings.

- Lines terminating at a generating plant, where a generating plant stability constraint is addressed by an operating limit or Special Protection System (SPS) (including line-out conditions).
- Lines that are associated with a System Operating Limit (SOL) that has been established based on stability constraints identified in system planning or operating studies (including line-out conditions).
- Lines that have tripped due to power swings during system disturbances.
- Lines that form a boundary of the Bulk Electric System that may form an island.<sup>14</sup>
- Lines identified through other studies, including but not limited to, event analyses and transmission planning or operational planning assessments.

### **Benefits of Defining Applicability for Specific Circuit Characteristics**

Limiting the applicability of a Reliability Standard provides a number of benefits.

- Efforts may be more focused, creating the possibility to include dynamic simulations assessing a greater number of fault types and system configurations.
- It may be possible, subject to relay model availability, to model specific relay settings in the dynamic simulation software, to more precisely identify the likelihood of a stable swing entering the relay characteristic. Including relay models in transient stability simulations could be used to monitor security of settings and identify potential concerns. Present software and computing developments are reducing limitations that historically have prevented such modeling, as well as practical limits to managing the volume of data. However, models are not presently available for all tripping relay characteristics, such as when load encroachment features are used to limit the trip characteristic to meet relay loadability requirements.

### **Requirements**

The following requirements should be applicable to the circuits identified in the preceding section to mitigate the risk of protection systems operating during stable power swings.

- A requirement for each Reliability Coordinator and Planning Coordinator to identify lines that meet the criteria in the applicability section and notify the owners of applicable circuits.

---

<sup>14</sup> See NERC Reliability Standard PRC-006-1 – Automatic Underfrequency Load Shedding, Requirement R1.

A Functional Model entity with a wide-area view should have responsibility for identifying the circuits to which the standard is applicable. This approach promotes consistent application of the criteria and assures that facility owners are aware of their responsibilities, given that a facility owner may not be aware of all relevant system studies. It is most appropriate to assign this responsibility to the Reliability Coordinator and the Planning Coordinator given their wide-area view and awareness of reliability issues. Both entities should be involved since stability issues may be identified in both operating and planning studies. The standard should require periodic review to assure the list of applicable circuits is up-to-date.

- A requirement for each facility owner to document its basis for applying protection to each of its applicable circuits (as identified above), and provide this information to its Reliability Coordinator, Planning Coordinator, and Transmission Planner.<sup>15</sup>

There are multiple ways for a facility owner to mitigate the potential of protection systems tripping for stable power swings. In some cases conventional impedance-based protection may be acceptable (e.g., on a short line a mho characteristic may not be susceptible to tripping for stable swings), in other cases a modified protection characteristic may be suitable, in some cases it may be appropriate to supervise the protection to enable or to block tripping during power swings, and in some cases the consequences of failing to trip for an unstable swing may be so significant that a risk of tripping for some stable swings is deemed in the best interest of Bulk-Power System reliability. Decisions whether to apply out-of-step protection should be made between the facility owner who has knowledge of the protection system design and the Reliability Coordinator, Planning Coordinator, and Transmission Planner who have knowledge of the characteristics of the power system performance. The documented basis should include rationale for whether out-of-step protection is needed, and if so, whether out-of-step tripping or power swing blocking is applied. Although this requirement is focused on documentation, this information is necessary for Reliable Operation of the Bulk-Power System. Entities responsible for operating and planning the Bulk-Power System need this information to understand how protection systems may respond during extreme system conditions.

Entities may find the information presented in the appendices of this report useful in developing a basis for applying protection to each applicable line.

The SPCS discussed additional requirements related to modeling the tripping functions of phase protection systems responsive to power swings. Modeling these protective functions in transient stability simulations could be an effective method of verifying that protection systems will not operate on stable power swings. Default phase distance relay models exist in simulation software that can be used to monitor apparent impedance and identify lines and conditions where relay operation is possible, as well as explicit models for many typical trip function characteristics. However, existing models do not address some of the unique features, such as load encroachment, that many entities have utilized to meet the transmission relay loadability requirements. The SPCS supports use of existing relay models in operating studies and transmission planning assessments; however, the SPCS believes is not possible to implement a measurable requirement until explicit models are available. NERC, through its technical committees, could monitor the availability of relay models and provide further recommendations at an appropriate time.

Modeling the tripping functions of phase protection systems responsive to power swings would enable the Reliability Coordinator, Planning Coordinator, and Transmission Planner to identify cases for which the protection systems applied are susceptible to tripping on stable power swings. Simulation results could provide important feedback since it is not practical to consider every potential power swing at the time settings are applied to a protection system. Given the difficulty of identifying all potential power swings, it is important that any information obtained through actual events and system studies is evaluated by the facility owner. In some cases this new information may identify the need to modify a protection system design or its settings. Decisions to modify a protection system, or not, should be made between the facility owner who has knowledge of the protection system design and the Reliability Coordinator, Planning Coordinator, and Transmission Planner who have knowledge of the characteristics of both the power system performance and protection system design. Decisions whether to modify a protection system should consider the need for dependable tripping during unstable power swings in addition to the objective of secure operation for stable power swings.

---

<sup>15</sup> This and subsequent requirements should include all entities responsible for assessing dynamic performance of the Bulk-Power System. The Reliability Coordinator has responsibility for operating studies and the Planning Coordinator and Transmission Planner have responsibility for transmission planning assessments.

## Conclusions

---

Operation of transmission line protection systems was not causal or contributory to six of the most significant system disturbances that have occurred since 1965. System separation during several of these disturbances did occur due to unstable power swings, and it is likely that the scope of some events and potential for equipment damage would have been greater without dependable tripping on unstable swings to physically separate portions of the system that lost synchronism.

Given the relative risks associated with a lack of dependable operation for unstable power swings and the lack of secure operation for stable swings, it is generally preferable to emphasize dependability over security when it is not possible to ensure both for all possible system conditions. Prohibiting use of certain types of relays may have unintended negative outcomes for Bulk-Power System reliability.

Efforts to improve transmission relay loadability subsequent to the August 14, 2003 northeast blackout had a secondary effect of reducing the susceptibility of some protection systems to tripping on stable power swings. While it is not possible to quantify the extent to which these modifications improved security against tripping for stable power swings, reducing the resistive reach of phase distance protection functions does increase the power system angular separation necessary to enter the relay characteristic.

Although current-only-based protection is immune to operating during power swings, exclusive use of current-only-based protection is not practical and would reduce dependability of tripping for system faults and unstable power swings. A power system with no remote backup protection is susceptible to uncleared faults and the inability to separate during unstable power swings during extreme system events. Although current-only-based protection is secure for stable power swings and can be used on lines which require tripping on out-of-step conditions, additional separate out-of-step protection is required. Application of impedance-based backup protection and, where necessary, out-of-step protection, reintroduces the need to discriminate between stable and unstable power swings.

Although many new algorithms exist to discriminate between stable and unstable swings, testing out-of-step functions using actual power system swings has identified susceptibility of some protection systems to misoperate, which highlights the difficulty of providing both dependable and secure operation.

## Recommendations

---

Based on its review of historical events, consideration of the trade-offs between dependability and security, and recognizing the indirect benefits of implementing the transmission relay loadability standard (PRC-023), the SPCS concludes that a NERC Reliability Standard to address relay performance during stable swings is not needed, and could result in unintended adverse impacts to Bulk-Power System reliability.

While the SPCS recommends that a Reliability Standard is not needed, the SPCS recognizes the directive in FERC Order No. 733 and the Standards Committee request for research to support Project 2010-13.3. Therefore, the SPCS provides recommendations for applicability and requirements that can be used if NERC chooses to develop a standard.

# Appendix A – Overview of Power Swings

## General Characteristics

An electric power grid, consisting of generators connected to loads via transmission lines, is constantly in a dynamic state as generators automatically adjust their output to satisfy real and reactive power demand. During steady-state operating conditions, a balance exists between the power generated and the power consumed, with the absolute differences in the voltages between buses typically maintained within 5 percent and frequency within 0.02 Hz of nominal. In the balanced system state, each generator in the system maintains its voltage and internal machine rotor angle at an appropriate relationship with the other generators as dictated by required power flow conditions in the system.

Sudden changes in electrical power caused by power system faults, line switching, generator disconnection, or the loss or connection of large blocks of load, disturb the balance between the mechanical power into and the required electrical power out of generators, causing acceleration or deceleration of the generating units because the mechanical power input responds more slowly than the generator electrical power. Such system disturbances cause the machine rotor angles of the generators to swing or oscillate with respect to one another in the search for a new equilibrium state. During this period, transmission lines will experience power swings, which can be stable or unstable, depending of the severity of the disturbance. In a stable swing, the power system will return to a new equilibrium state where the generator machine rotor angle differences are within stable operating range to generate power that is balanced with the load. In an unstable swing, the generation and load do not find a balance and the machine rotor angles between coherent groups of generators continue to increase, eventually leading to loss of synchronism between the coherent groups of generators. The location at which loss of synchronism occurs is based on the physical attributes of the system and is unlikely to correspond to boundaries between neighboring utilities. When synchronism is lost among areas of a power system, the areas should be separated quickly to avoid equipment damage and to avoid possible collapse of the entire power system. Ideally, the system is separated at predetermined locations into self-contained areas, each of which can maintain a generation/load balance, where the attainment of the balance may require appropriate generation or load shedding.

## Impedance Trajectory

The dynamic state of the power system can be represented by the impedance “seen” at a bus in the power system. The two machine equivalent shown in Figure 6 can be used to illustrate the concept, where the source voltages at the two ends of the system,  $E_G$  and  $E_H$ , are constant magnitudes behind their transient impedances,  $Z_G$  and  $Z_H$ .

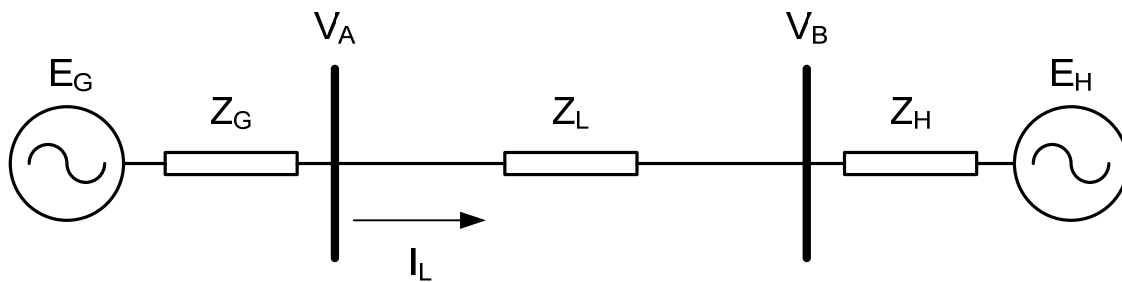
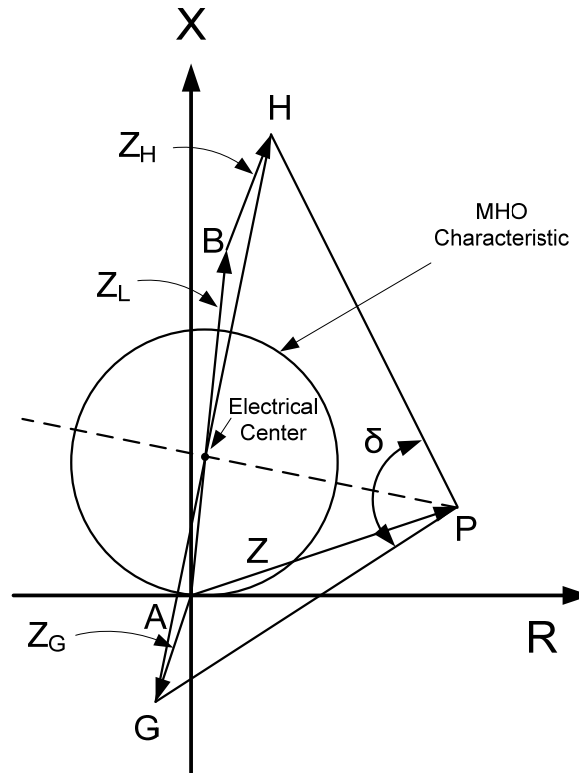


Figure 6: Two-Machine Equivalent of a Power System

Figure 7, the geometrical interpretation of the power equation for this simple two source system, shows the R-X diagram with a mho characteristic of the relay at Bus A, set to a typical zone 1 setting for protection of the line (line impedance is  $Z_L$ ). The total impedance across the system is represented by Points G to H, where  $Z_G$  extends from the origin to point G in the third quadrant and  $Z_H$  extends from the tip of  $Z_L$  to Point H in the first quadrant.

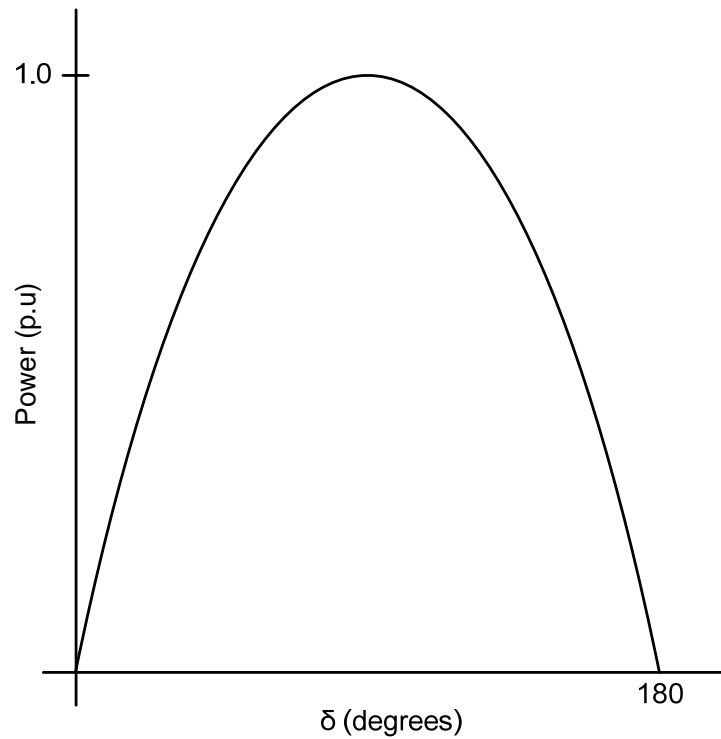




**Figure 7: Illustration of Electrical Center of the Equivalent Power System**

With  $E_G$  and  $E_H$  of equal magnitude and with a phase angle difference of  $\delta$  ( $E_G$  leading) the apparent impedance during a swing will fall on a straight line perpendicular to and bisecting the total system impedance between G and H. As source  $E_G$  moves ahead of source  $E_H$  in angle during a swing (with magnitudes of  $E_G$  and  $E_H$  equal), the angle  $\delta$  increases. On the R-X diagram, the angle formed by the intersection of lines PG and PH at P is the angle of separation between the source voltages  $E_G$  and  $E_H$ . Point P on the R-X diagram of Figure 7 is the apparent impedance seen at Bus A. When  $\delta = 90^\circ$ , the impedance lies on the circle whose diameter is the total impedance (GH) across the system. This is the point of maximum load transfer between G and H. When  $\delta$  reaches  $120^\circ$ , and beyond, the systems are not likely to recover.<sup>16</sup> When the locus intersects the total system impedance line GH,  $\delta$  is  $180^\circ$  and the systems are completely out of phase. This point is called the electrical center (at the mid-point of the total system impedance when  $E_G$  and  $E_H$  are of equal magnitude). The voltage is zero at this point and, therefore, it is equivalent to a three-phase fault at the electrical center. As the impedance locus moves to the left of impedance line GH,  $\delta$  increases beyond  $180^\circ$  and eventually the systems will be in phase again. If the systems are not separated, source  $E_G$  continues to move ahead of source  $E_H$ , and the cycle repeats itself. When the impedance locus reaches the starting point of the swing, one slip cycle has been completed.

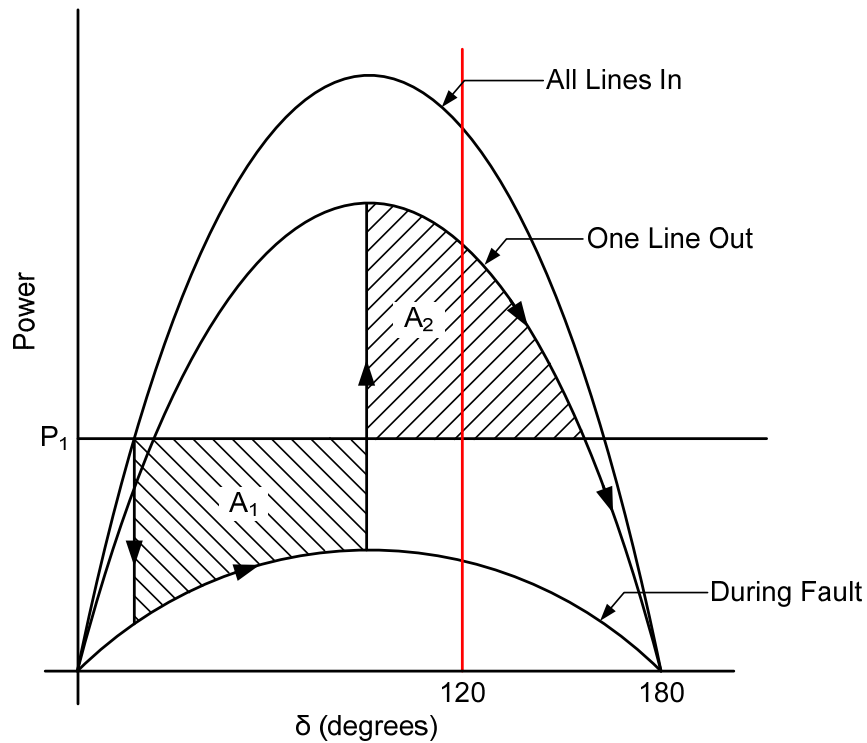
<sup>16</sup> [Application of Out-of-Step Blocking and Tripping Relays, John Berdy.](#)



**Figure 8: Power Angle Curve**

Figure 8 plots the power angle equation and shows the theoretical power transfer across a simplified transmission system such as that shown in Figure 6 for various values of  $\delta$  where  $\delta$  is the angular difference between the voltages at the two ends of the system. Normally, systems and transmission lines operate at low  $\delta$  angles that are perhaps 30 degrees or less (longer lines and weaker systems may operate at higher angles and shorter lines and stronger systems operate at lower angles).

Transmission of power in actual power systems is more complex than in the simple two source model discussed above. Two systems of coherent generators are typically connected by several lines of varying voltages. The plot of the power angle equation will vary with system conditions. An example is illustrated in Figure 9. This example illustrates conditions that may exist during a severe destabilizing fault and its aftermath. Prior to the fault, the system is stable, transmitting an amount of power  $P_1$  from one system to the other. When the severe fault occurs, the transfer capability of the system is reduced. The power delivered by the generators is less than the input from their prime movers, which causes the sending generators to accelerate, increasing the angle between the systems. When the faulted line is cleared, the transfer capability is increased, but to a lower level than the pre-fault level, due to the loss of the faulted line. The power delivered by the accelerated generators at this angle is greater than the input from their prime movers, which causes the generators to decelerate. For this condition, the system angle will continue to increase as the generators decelerate. If the angle is greater than 90 degrees, then the angle increases as the power delivered is lowered and the deceleration rate is reduced. If the angle reaches 120 degrees and is still increasing, it is likely that the system will not reach equilibrium (the decelerating area  $A_2$  equals the accelerating area  $A_1$ ) before the power delivered by the generators decreases below the prime mover inputs. If that occurs, the generators will accelerate again and pull out of synchronism.



**Figure 9: Power Angle Curve for Various Conditions**

At any given relay location, it is impossible to predict all possible system configurations and power transfer capabilities. The critical angle for maintaining stability will vary depending on the contingency and the system condition at the time the contingency occurs; however, the likelihood of recovering from a swing that exceeds 120 degrees is marginal and 120 degrees is generally accepted as an appropriate basis for setting out-of-step protection.<sup>17</sup> Given the importance of separating unstable systems, defining 120 degrees as the critical angle is appropriate to achieve a proper balance between dependable tripping for unstable power swings and secure operation for stable power swings.

<sup>17</sup> Ibid.

# Appendix B – Protection Systems Attributes Related to Power Swings

---

## Desired Response

A transmission line protection system is required to detect line faults and trip appropriately. This applies during swing conditions where, in addition, the following also applies:

- (a) If the power swing is stable, from which the system will recover, a line protection should not operate because the unnecessary loss of lines could exacerbate the power swing to the extent that a stable swing becomes unstable. Hence, in this case, the relevant protections should be set to not operate on detection of a power swing. This may be achievable by selection of the protection system operating characteristics and settings, or may require dedicated logic to block operation.
- (b) If the power swing is unstable, also referred to as an out-of-step condition, separation at predetermined locations is desirable, as previously mentioned. To this end, line protection systems that should not trip on the out-of step condition should be blocked, while protection systems on lines that have been identified as the desired separation points should have out-of-step tripping capability.

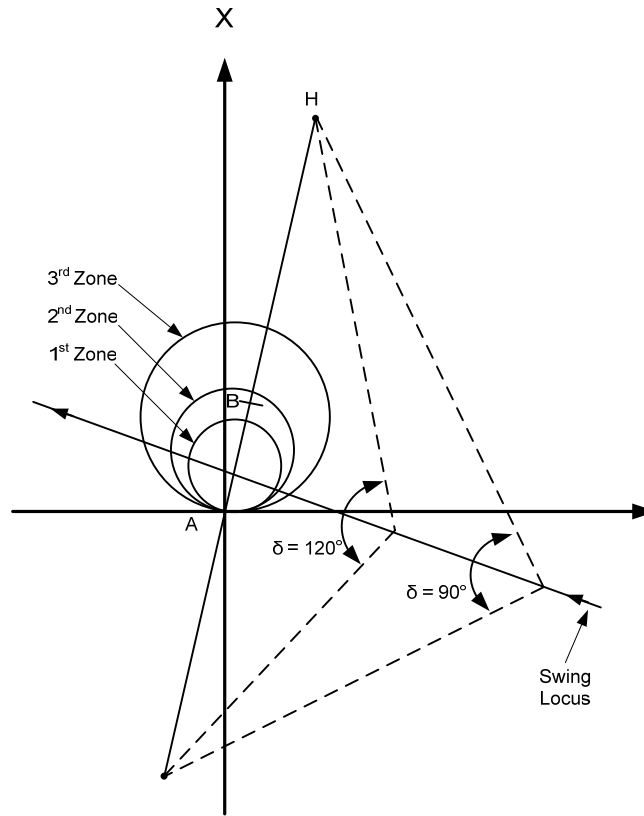
The blocking requirements set out in (a) and (b) above create a condition where if an internal fault occurs during the power swing, the line protection is unable to perform its protection function, unless the blocking is removed. The challenge is the manner in which the blocking can be reliably removed. Methods that have been used to address this condition are discussed in the IEEE Power System Relaying Committee Working Group WG D6 report, *Power Swing and Out-of-Step Considerations on Transmission Lines*, July 2005..

## Response of Distance Protection Schemes

### Power Swing Without Faults

#### *Distance Elements*

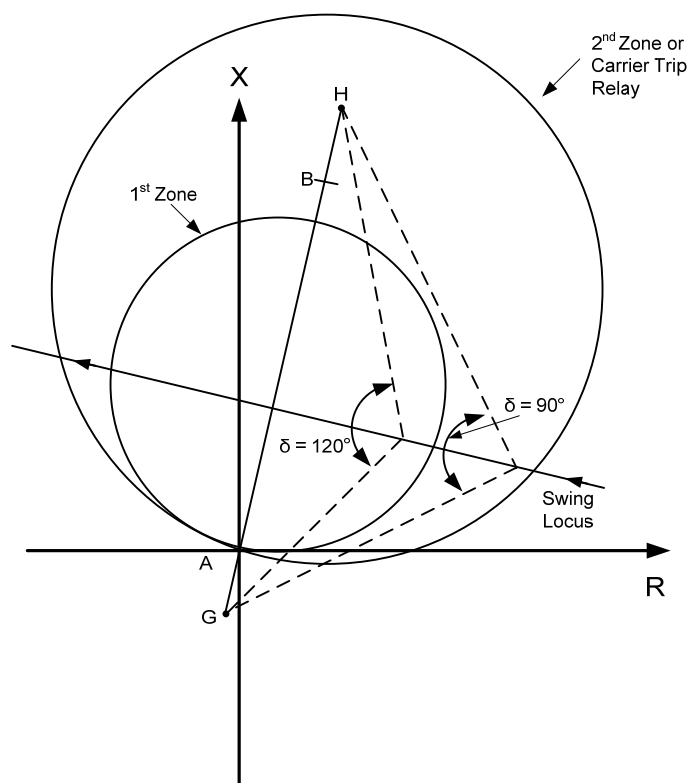
While it is evident from the illustration in Figure 7 that a swing locus can cause the apparent impedance to enter the relay element characteristic, resulting in operation of the element, the performance of distance elements is dependent to some extent on the relative magnitudes of system and line impedances. For example, if the line impedance is small compared to the system impedances, it is likely that the various distance zones will trip only on swings from which the system will not recover. This is illustrated in Figure 10 for the relay at Bus A (with three zones), showing that the swing locus will only enter the distance relay characteristics when the angular separation between sources  $E_G$  and  $E_H$  exceeds  $120^\circ$ . In the case illustrated, the angle must significantly exceed  $120^\circ$ . If the swing locus does not traverse zone 1 but traverses zone 2, the response of the line protection depends on the scheme used, as discussed in the sections below.



**Figure 10: Line Impedance is Small Compared to System Impedances**

When the line impedance is large compared to the system impedances, the distance relay elements could operate for swings from which the system could recover. This is illustrated in the example shown in Figure 11, where two zones are shown for clarity. It is evident that zone 2 will operate before the angular separation of the systems exceeds  $90^\circ$ , while zone 1 will operate before angular separation of  $120^\circ$  is reached. In this case the protection system is susceptible to tripping on a stable power swing unless the relay characteristic is modified or some form of blocking is provided to prevent tripping.

Time delayed zone 2 relays in a step distance scheme will trip if the locus resides within the characteristic for a time exceeding the delay setting.



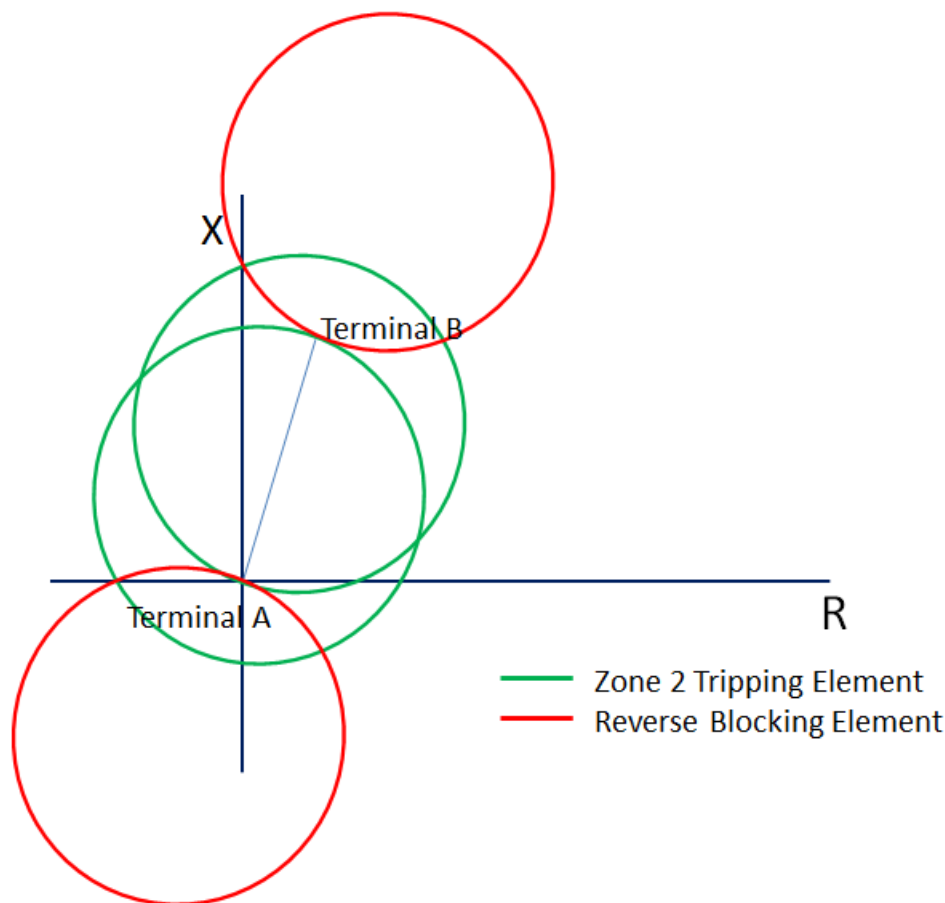
**Figure 11: Line Impedance is Large Compared to System Impedances**

***Distance Relay Based Pilot Scheme Response to Power Swings***

Figure 12 Shows impedance elements as they are typically applied in directional comparison pilot schemes. The green characteristics represent zone 2 tripping elements. The tripping elements are used in both Directional Comparison Blocking (DCB) schemes, and Permissive Over Reaching (POR) schemes. The red characteristics represent blocking elements. They are used in all DCB schemes and many variations of POR schemes. Depending on the path of the impedance locus, power swings will affect the performance of DCB and POR schemes differently.

To cause a POR scheme to open a line, the impedance locus must be within both zone 2 tripping characteristics simultaneously. For POR schemes employing transient blocking functions, the locus must enter both tripping characteristics within a short time of each other, usually within about a power cycle. A DCB scheme will open at least one line terminal any time the locus enters either tripping characteristic, without also entering a blocking characteristic.

If the locus enters a blocking element, DCB schemes will transmit blocking signals, and POR terminals with blocking elements will not respond to received permissive signals. If a fault occurs on the protected line subsequent to the power swing locus entering the blocking element, a DCB scheme will trip. The performance of the POR terminal will depend on the system strength behind the terminal and on details of the permissive scheme logic associated with the blocking function.



**Figure 12: Directional Comparison Trip and Block**

### ***Response of Line Current Differential Protections***

With recent advancements in digital communication systems, the current differential principle has been effectively applied to line protection, providing good sensitivity for detection of line faults, including high resistance ground faults, while maintaining high degree of selectivity between internal and external faults. Many of these characteristics apply during power swing and out-of-step conditions. With the current differential principle measuring the current at one terminal of the line and computing the differential current with the current levels transmitted from the other terminal(s), the protection remains secure during a swing condition because the computed differential current remains below the threshold that would signify a fault. With increasing angular separation between the swinging systems, the current levels at each of the terminals increase beyond normal load levels, making the condition look like a through fault. Phase comparison protection systems exhibit performance similar to current differential protection systems.

One shortcoming in the characteristics of these current-only-based protections is that during some portion of the power swing, the protection could become insensitive to line faults. For example, if a line fault occurs at the electrical center of a two-terminal system when the angular separation between the swinging systems is  $180^\circ$ , the current levels at the two terminals are equal in magnitude and opposite in phase. This results in zero difference current, rendering the protection blind to this fault condition. However, as the power swing moves away from the electrical center (i.e., as the angular separation becomes different from  $180^\circ$ ), the difference current becomes non-zero, re-establishing the protection's sensitivity to detection of faults on the line being protected. Hence, the existence of the blind spot could delay the detection of some faults, as the angular separation needs to move from a less favorable to a more favorable value. The impact of this delay is system dependent, i.e., if the system slip is relatively fast, the delay could be minimal. For example, at slip frequency of 5 Hz, angular separation of  $180^\circ$  takes place in 100 ms. so the blind spot could last for less than 10 ms. The blind spot lasts for correspondingly longer periods of time when the slip frequency is reduced.

The shortcoming discussed above may be inconsequential in many applications; however, current-only-based protection systems have another shortcoming because backup protection is needed to address failures of the communication channel. In practice, a second independent current-based protection scheme could be applied to provide backup protection. However, a power system with no remote backup protection is susceptible to uncleared faults unless back-up protection is applied. Although a current-only-based protection system is secure for stable power swings and can be used on lines which require tripping on out-of-step conditions, an out-of-step tripping protection function is still required. Using an impedance-based back-up protection or out-of-step tripping function reintroduces the need to discriminate between stable and unstable power swings. The shortcomings of impedance-based out-of-step tripping functions can be mitigated by applying an integrated out-of-step tripping function that is supervised by non impedance-based algorithms; however, testing out-of-step tripping functions using simulated power system swings from the August 14, 2003 blackout investigation has identified susceptibility of some such protection systems to misoperate.



## Appendix C – Overview of Out-of-Step Protection Functions

### Power Swing and Out-of-Step Phenomenon

A power swing is a system phenomenon that is observed when the phase angle of one power source varies in time with respect to another source on the same network. The phenomenon occurs following any system perturbation, such as changes in load, switching operations, and faults, that alters the mechanical equilibrium of one or more machines. A power swing is stable when, following a disturbance, the rotation speed of all machines returns to synchronous speed. A power swing is unstable when, following a disturbance, one or more machines do not return to synchronous speed, thereby losing synchronism with the rest of the system.

### Basic Phenomenon Using the Two-Source Model

The simplest network for studying the power swing phenomenon is the two-source model, as shown in Fig. 12. The left source has a phase angle advance equal to  $\theta$ , and this angle will vary during a power swing. The right source represents an infinite bus, and its angle will not vary with time. This elementary network can be used to understand the behavior of more complex networks, although it has limitations when considering swings with multiple modes and time-varying voltages.

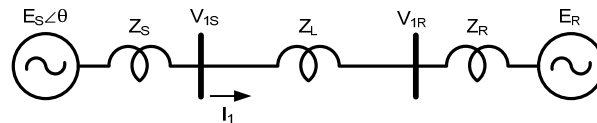


Figure 13: Two-source Equivalent Elementary Network

### Representation of Power Swings in the Impedance Plane

Assuming the sources have equal impedance amplitude, for a particular phase angle  $\theta$ , the location of the positive-sequence impedance ( $Z_1$ ) calculated at the left bus is provided by the following equation [1]:

$$Z_1 = \frac{V_{1S}}{I_1} = Z_T \cdot \frac{E_S \angle \theta}{E_S \angle \theta - E_R} - Z_S \quad (1)$$

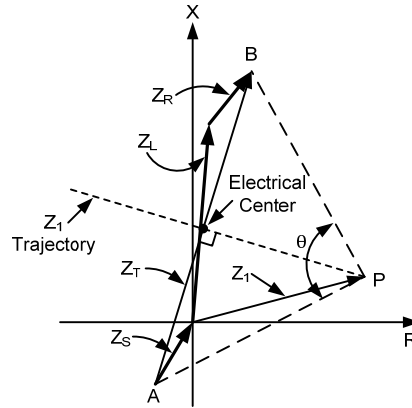
In (1),  $Z_T$  is the total impedance, as in:

$$Z_T = Z_S + Z_L + Z_R \quad (2)$$

Assuming the two sources are of equal magnitude, the  $Z_1$  impedance locus in the complex plane is given by (3).

$$Z_1 = \frac{Z_T}{2} \cdot \left( 1 - j \cot \frac{\theta}{2} \right) - Z_S \quad (3)$$

When the angle  $\theta$  varies, the locus of the  $Z_1$  impedance is a straight line that intersects the segment  $Z_T$  orthogonally at its middle point, as shown in Figure 14. The intersection occurs when the angular difference between the two sources is 180 degrees. When a generator torque angle reaches 180 degrees, the machine is said to have slipped a pole, reached an out-of-step (OOS) condition, or lost synchronism.

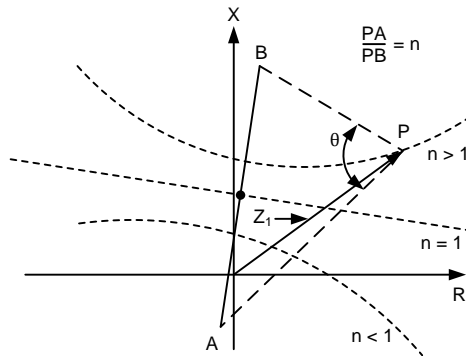


**Figure 14: Locus of the Z1 Impedance During a Power Swing with Sources of Equal Magnitude**

When the two sources have unequal magnitudes such that  $n$  is the ratio of  $E_S$  over  $E_R$ , the locus of the  $Z_1$  impedance trajectory will correspond to the circles shown in Figure 15. For any angle  $\theta$ , the ratio of the two segments joining the location of the extremity of  $Z_1$  (Point P) to the total impedance extremities A and B is equal to the ratio of the source magnitudes.

$$n = \frac{E_S}{E_R} = \frac{PA}{PB} \tag{4}$$

The precise equation for the center and radius of the circles as a function of the ratio  $n$  can be found in [1].



**Figure 15: Locus of the Z1 Impedance During a Power Swing with Sources of Unequal Magnitude**

It should be noted that synchronous generators are not ideal voltage sources as represented in the equivalent two-source model. Furthermore, the impact of automatic voltage regulators must be considered. During a power swing, the ratio of two power source magnitudes will not remain constant. Therefore, the resulting locus of the  $Z_1$  impedance will not follow a unique circle, with the trajectory depending upon the instantaneous voltage magnitude ratio.

### Rate of Change of the Positive-Sequence Impedance

Starting with (1) and assuming the two sources are of equal magnitude, the time derivative of the  $Z_1$  impedance is provided by (5) [2].

$$\frac{dZ_1}{dt} = -jZ_T \cdot \frac{e^{-j\theta}}{(1 - e^{-j\theta})^2} \cdot \frac{d\theta}{dt} \tag{5}$$

Assuming the phase angle has a linear variation with a slip frequency in radians per second given as:

$$\frac{d\theta}{dt} = \omega \tag{6}$$

and using the identity:

$$|1 - e^{-j\theta}| = 2 \cdot \sin \frac{\theta}{2} \quad (7)$$

the rate of change of the Z<sub>1</sub> impedance is finally expressed as:

$$\left| \frac{dZ_1}{dt} \right| = \frac{|Z_T|}{4 \cdot \sin^2 \frac{\theta}{2}} \cdot |\omega| \quad (8)$$

Equation (8) expresses the principle that the rate of change of the Z<sub>1</sub> impedance depends upon the sources, transmission line impedances, and the slip frequency, which, in turn, depend upon the severity of the power system disturbance.

As a consequence, any algorithm that uses the Z<sub>1</sub> impedance displacement speed in the complex plane to detect a power swing will depend upon the network impedances and the nature of the disturbance. Furthermore, the source impedances vary during the disturbance and typically are not introduced into the relay settings so the relay cannot usually predict the displacement speed.

## Out-of-Step Protection Functions

The detection of power swings is performed with two fundamental functions: the power swing blocking (PSB) function and the out-of-step tripping (OST) function [3]. The PSB function discriminates faults from stable or unstable power swings. The PSB function blocks relay elements that are prone to operate during stable or unstable power swings to prevent system separation in an indiscriminate manner. In addition, the PSB function unblocks previously blocked relay elements and allows them to operate for faults, in their zone of protection, that occur during an out-of-step (OOS) condition.

The OST function discriminates stable from unstable power swings and initiates network islanding during loss of synchronism. OST schemes are designed to protect the power system during unstable conditions, isolating unstable generators or larger power system areas from each other with the formation of system islands, to maintain stability within each island by balancing the generation resources with the area load.

To accomplish this, OST systems must be applied at preselected network locations, typically near the network electrical center. The isolated portions of the system are most likely to survive when network separation takes place at locations that preserve a close balance between load and generation. Since it is not always possible to achieve a load-generation balance, some means of shedding nonessential load or generation is necessary to avoid a collapse of the isolated portions of the power system.

Many relay systems are prone to operate during an OOS condition, which may result in undesired tripping. Therefore, OST systems may need to be complemented with PSB functions to prevent undesired relay system operations and to achieve a controlled system separation. When transmission separation schemes trip before fault protective relays operate, it may be desirable to not use the PSB function so that the fault protection can provide a last line of defense against asynchronous conditions.

Typically, the location of OST relay systems determines the location where system islanding takes place during loss of synchronism. However, it may be necessary in some systems to separate the network at a location other than the one where OST is installed. This is accomplished with the application of a transfer tripping type of scheme.

Uncontrolled tripping during OOS conditions can cause damage to power system breakers due to high transient overvoltages that appear across the breaker contacts when switching a line that contains the electrical center of a power swing. The maximum transient recovery voltage occurs when the relative phase angle of the two systems is 180° during the OOS condition. Circuit breaker opening angle should be considered in applying out-of-step protection for transmission circuits because opening at angles greater than 120 degrees may cause excess voltage stress on the circuit breaker. When selecting out-of-step relay settings it may be necessary to balance the potential breaker opening angle, the potential adverse impact of transmission voltage dips associated with a loss of synchronism, and the need to avoid tripping for recoverable swings.

## Power Swing Detection Methods

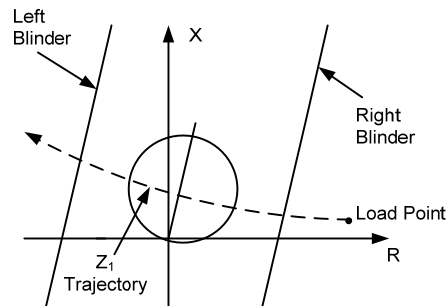
There are many different methods that are used to detect power swings, each with its strengths and drawbacks [4]. This section presents some of those detection methods.

### ***Conventional Rate of Change of Impedance Methods***

The rate of change of impedance methods are based on the principle that the  $Z_1$  impedance travels in the complex plane with a relatively slow speed, whereas during a fault,  $Z_1$  switches from the load point to the fault location almost instantaneously.

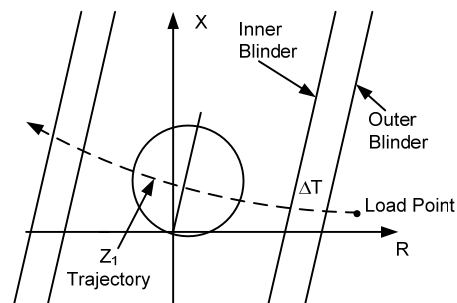
### ***Blinder Schemes***

Figure 16 shows an example of a single-blinder scheme. This scheme detects an unstable power swing when the time interval required to cross the distance between the right and left blinders exceeds a minimum time setting. The scheme allows for the implementation of OST on the way out of the zone and cannot be used for PSB because the mho characteristics will be crossed before the power swing is detected. This method is most commonly implemented in conjunction with generator protection and not line protection.



**Figure 16: Single-Blinder Characteristic**

Figure 17 shows an example of a dual-blinder scheme. During a power swing, the dual-blinder element measures the time interval  $\Delta T$  that it takes the  $Z_1$  trajectory to cross the distance between the outer and inner blinders. When this measured time interval is longer than a set time delay, a power swing is declared. The set time delay is adjusted so that it will be greater than the time interval measured during a fault and smaller than the time interval measured during the  $Z_1$  travel at maximum speed. Using the dual-blinder scheme, an OST scheme can be set up to either trip on the way into the zone or on the way out of the zone.

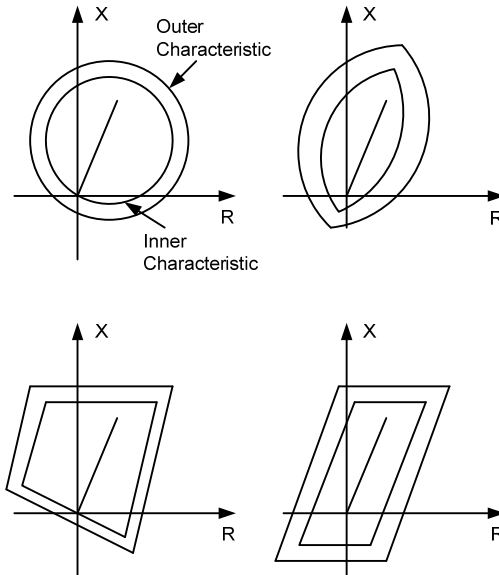


**Figure 17: Dual-Blinder Characteristic**

### ***Concentric Characteristic Schemes***

Concentric characteristics for the detection of power swings work on the same principle as dual-blinder schemes: after an outer characteristic has been crossed by the  $Z_1$  impedance, a timer is started and the interval of time before the inner characteristic is reached is measured. A power swing is detected when the time interval is longer than a set time delay.

Characteristics with various shapes have been used, as shown in Figure 18. The dual-quadrilateral characteristic represented at the bottom right of Figure 18 has been one of the most popular.

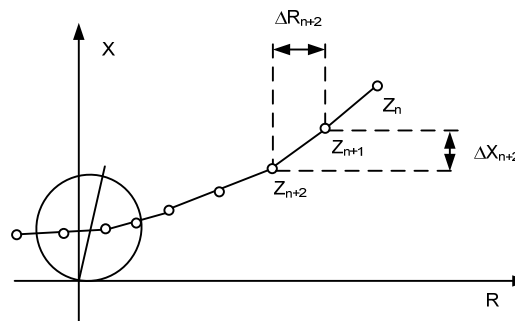


**Figure 18: Concentric Characteristic of Various Shapes**

### ***Nonconventional Power Swing Detection Methods***

#### **Continuous Impedance Calculation**

The continuous impedance calculation consists of monitoring the progression in the complex plane (Figure 19) of three modified loop impedances [5]. A power swing is declared when the criteria for all three loop impedances have been fulfilled: continuity, monotony, and smoothness. Continuity verifies that the trajectory is not motionless and requires that the successive  $\Delta R$  and  $\Delta X$  be above a threshold. Monotony verifies that the trajectory does not change direction by checking that the successive  $\Delta R$  and  $\Delta X$  have the same signs. Finally, smoothness verifies that there are no abrupt changes in the trajectory by looking at the ratios of the successive  $\Delta R$  and  $\Delta X$  that must be below some threshold.



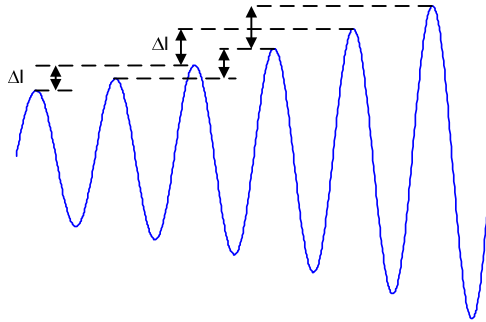
**Figure 19: Continuous Impedance Calculation**

The continuous impedance calculation is supplemented by a concentric characteristic to detect very slow-moving trajectories.

One of the advantages of the continuous impedance calculation is that it does not require any settings and can handle slip frequencies up to 7 Hz. It does not require, therefore, any power swing studies involving complex simulations.

**Continuous Calculation of Incremental Current**

During a power swing, both the phase voltages and currents undergo magnitude variations. The continuous calculation of the incremental current method computes the difference between the present current sample value and the value stored in a buffer 2 cycles before (see Figure 20). This method declares a power swing when the absolute value of the measured incremental current is greater than 5 percent of the nominal current and that this same condition is present for a duration of 3 cycles [6].



**Figure 20: Continuous Calculation of Incremental ΔI**

The main advantage of the continuous calculation of incremental current is that it can detect very fast power swings, particularly for heavy load conditions.

**R-Rdot OOS Scheme**

The R-Rdot relay for OST was devised specifically for the Pacific 500 kV ac intertie and was installed in the early 1980s. The R-Rdot relay uses the rate of change of resistance to detect an OOS condition.

An impedance-based control law for OOS detection is created by defining the following function [7-8]:

$$U_1 = (Z - Z_1) + T_1 \cdot \frac{dZ}{dt} \tag{9}$$

If we define a phase plane where the abscissa is the impedance magnitude and the ordinate is the rate of change of the impedance magnitude, (9) represents a switching line. An OOS trip is initiated when the switching line is crossed by the impedance trajectory from right to left. The effect of adding the impedance magnitude derivative is that the tripping will be faster at a higher impedance changing rate. At a small impedance changing rate, the characteristic is equivalent to the conventional OOS scheme.

In the R-Rdot characteristic, the impedance magnitude is replaced by the resistance measured at the relay location and the rate of change of the impedance magnitude is replaced by the rate of change of the measured resistance (see Figure 21). The advantage of this latter modification is that the relay becomes less sensitive to the location of the swing center with respect to the relay location.

$$U_1 = (R - R_1) + T_1 \cdot \frac{dR}{dt} \tag{10}$$

In the R-Rdot plane the switching line  $U_1$  is a straight line having slope  $T_1$ . System separation is initiated when output  $U_1$  becomes negative. For low separation rates (small  $dR/dt$ ), the performance of the R-Rdot scheme is similar to the conventional OST relaying schemes. However, higher separation rates ( $dR/dt$ ) would cause a larger negative value of  $U_1$  and initiate tripping much earlier. For a conventional OST relay without a rate of change of apparent resistance, augmentation is just a vertical line in the R-Rdot plane offset by the  $R_1$  relay setting parameter.

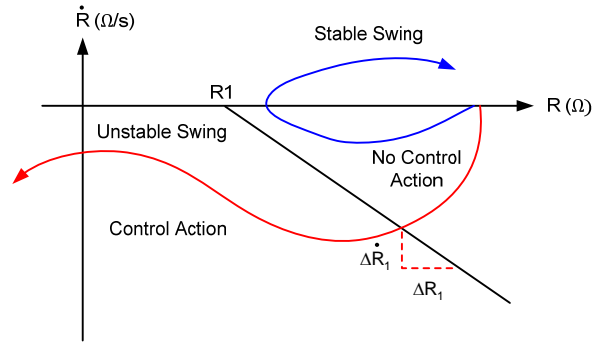


Figure 21: R-Rdot OOS Characteristic in the Phase Plane

**Rate of Change of Swing Center Voltage (SCV)**

SCV is defined as the voltage at the location of a two-source equivalent system where the voltage value is zero when the angles between the two sources are 180 degrees apart. Figure 22 illustrates the voltage phasor diagram of a general two-source system, with the SCV shown as the phasor from origin o to the point o'.

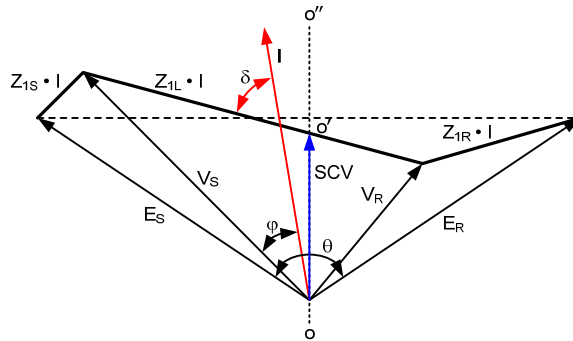


Figure 22: Voltage Phasor Diagram of a Two-Source System

When a two-source system loses stability and enters an OOS condition, the angle difference of the two sources,  $\theta(t)$ , increases as a function of time [2]. We can represent the SCV with (11), assuming equal source magnitudes in a two-source equivalent system,  $E = |E_S| = |E_R|$ .

$$SCV(t) = \sqrt{2}E \sin\left(\omega t + \frac{\theta(t)}{2}\right) \cdot \cos\left(\frac{\theta(t)}{2}\right) \quad (11)$$

SCV(t) is the instantaneous SCV that is to be differentiated from the SCV that the relay estimates. Equation (11) is a typical amplitude-modulated sinusoidal waveform. The first sine term is the base sinusoidal wave, or the carrier, with an average frequency of  $\omega + (1/2)(d\theta/dt)$ . The second term is the cosine amplitude modulation.

One popular approximation of the SCV obtained through the use of locally available quantities is as follows:

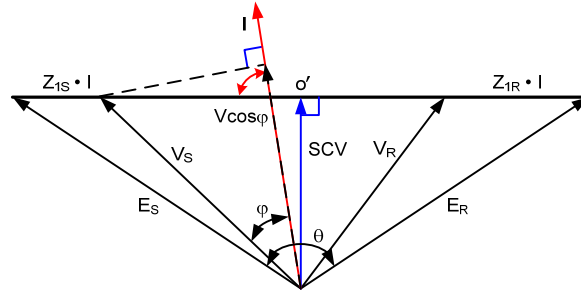
$$SCV \approx |V_S| \cdot \cos \phi \quad (12)$$

where:

$|V_S|$  is the magnitude of locally measured voltage.

$\phi$  is the angle difference between  $V_S$  and the local current, as shown in Figure 23.

The quantity of  $V \cos \phi$  was first introduced by Ilar for the detection of power swings [9].



**Figure 23:  $V\cos\phi$  is a Projection of Local Voltage,  $V_S$ , onto Local Current,  $I$**

In Figure 23, we can see that  $V\cos\phi$  is a projection of  $V_S$  onto the axis of the current,  $I$ . For a homogeneous system with the system impedance angles close to 90 degrees,  $V\cos\phi$  approximates well the magnitude of the SCV. For the purpose of power swing detection, it is the rate of change of the SCV that provides the main information of system swings. Therefore, some difference in magnitude between the system SCV and its local estimate has little impact in detecting power swings. We will, therefore, refer to  $V\cos\phi$  as the SCV in the following discussion.

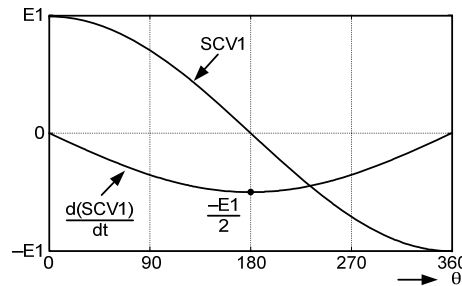
Using (11) and keeping in mind that the local SCV is estimated using the magnitude of the local voltage,  $V_S$ , the relation between the SCV and the phase angle difference,  $\theta$ , of two source voltage phasors can be simplified to the following:

$$SCV1 = E1 \cdot \cos\left(\frac{\theta}{2}\right) \quad (13)$$

In (13),  $E1$  is the positive-sequence magnitude of the source voltage,  $E_S$ , shown in Figure 23 and is assumed to be also equal to  $E_R$ . The time derivative of SCV1 is given by (14).

$$\frac{d(SCV1)}{dt} = -\frac{E1}{2} \sin\left(\frac{\theta}{2}\right) \frac{d\theta}{dt} \quad (14)$$

Equation (14) provides the relationship between the rate of change of the SCV and the two-machine system slip frequency,  $d\theta/dt$ . Equation (14) shows that the derivative of SCV1 is independent of power system impedances. Figure 24 is a plot of SCV1 and the rate of change of SCV1 for a system with a constant slip frequency of 1 radian per second.



**Figure 24: SCV1 and Its Rate of Change with Unity Source Voltage Magnitudes**

### ***Synchrophasor-Based OOS Relaying***

Consider the two-source equivalent network of Figure 13, and assume that the synchrophasors of the positive-sequence voltages are measured at the left and right buses as  $V_{1S}$  and  $V_{1R}$ .

The ratio of the two synchronized vectors is provided by the following equation:

$$\frac{V_{1S}}{V_{1R}} = \frac{\frac{Z_S}{Z_T} + (1 - \frac{Z_S}{Z_T}) \cdot k_E \angle \theta}{\frac{Z_S + Z_L}{Z_T} + (1 - \frac{Z_S + Z_L}{Z_T}) \cdot k_E \angle \theta} \quad (15)$$

where:



$k_E$  is the ratio of the magnitudes of the source voltages:

$$k_E = \frac{|E_S|}{|E_R|} \quad (16)$$

Assuming the source impedances are small with respect to the line impedance and the ratio  $k_E$  is close to 1, the ratio of the synchronized vectors can be approximated by unity for its magnitude and by the angle  $\theta$  between the two sources for its phase angle.

When using the two-source network equivalent, the result of (15) indicates that the ratio of the synchrophasors measured at the line extremities has a phase angle that can be approximated by the phase angle between the two sources. During a disturbance, the trajectory of the phase angle between the two phasors replicates the variation of the phase angle between the two machines. It is therefore possible to determine if an OOS condition is taking place when the measured phase angle trajectory becomes unstable [10].

Reference 10 presents the implementation of three functions based on synchrophasor measurements, the purpose of which is to trigger a network separation after a loss of synchronism has been detected. Positive-sequence voltage-based synchrophasors are measured at two locations of the network, assuming that the two-source equivalent can model the network. Following the measurement of the synchrophasors, two quantities are derived: the slip frequency  $S_R$ , which is the rate of change of the angle between the two measurements, and the acceleration  $A_R$ , which is the rate of change of the slip frequency. The three functions are defined as follows:

- Power swing detection is asserted when  $S_R$  is not zero and is increasing, which indicates  $A_R$  is positive and increasing.
- Predictive OST is asserted when, in the slip frequency against the acceleration plane, the trajectory falls in the unstable region (see Figure 25) defined by the condition:

$$A_R > 78\_Slope \cdot S_R + A_{Offset} \quad (17)$$

- OOS detection asserts when the absolute value of the angle difference between the two synchrophasors becomes greater than a threshold.

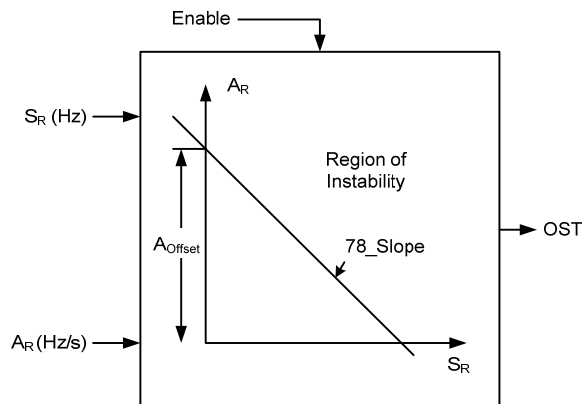


Figure 25: Predictive OST in the Slip-Acceleration Plane

A network separation or OST is initiated when the three functions are asserted.

### Out-of-Step Tripping Function

The OST function protects the power system during unstable conditions by isolating unstable generators or larger power system areas from each other by forming system islands. The main criterion is to maintain stability within each island. To accomplish this, OST systems should be applied at preselected network locations, typically near the network electrical center, to achieve a controlled system separation. The isolated portions of the system are most likely to survive when network separation takes place at locations in the network that preserve a close balance between load and generation.

Since it is not always possible to achieve a load-generation balance, some means of shedding load or generation is necessary to avoid a collapse of isolated portions of the power system.

OST systems may be complemented with PSB functions to prevent undesired relay system operations, equipment damage, and the shutdown of major portions of the power system. In addition, PSB blocking may be applied at other network locations to prevent system separation in an indiscriminate manner.

The selection of network locations for the placement of OST systems can best be obtained through transient stability studies covering many possible operating conditions. The maximum rate of slip is typically estimated from angular change versus time plots from stability studies. The stability study results are also used to identify the optimal location of OST and PSB relay systems, because the apparent impedance measured by OOS relay elements is a function of the MW and Mvar flows in transmission lines. Stability studies help identify the parts of the power system that impose limits on angular stability, generators that are prone to go out of step during system disturbances and those that remain stable, and groups of generators that tend to behave similarly during a disturbance.

Typically, the location of OST relay systems determines the location where system islanding takes place during loss of synchronism. However, in some systems, it may be necessary to separate the network at a location other than the one where OST is installed. This is accomplished with the application of a transfer tripping scheme. Current supervision may be necessary when performing OST at a different power system location than the location of OST detection to avoid issuing a tripping command to a circuit breaker at an unfavorable phase angle. Another important aspect of OST is to avoid tripping a line when the angle between systems exceeds the circuit breaker capability. Tripping during this condition imposes high stresses on the breaker and could cause breaker damage as a result of high recovery voltage across the breaker contacts, unless the breaker is rated for out-of-phase switching [11].

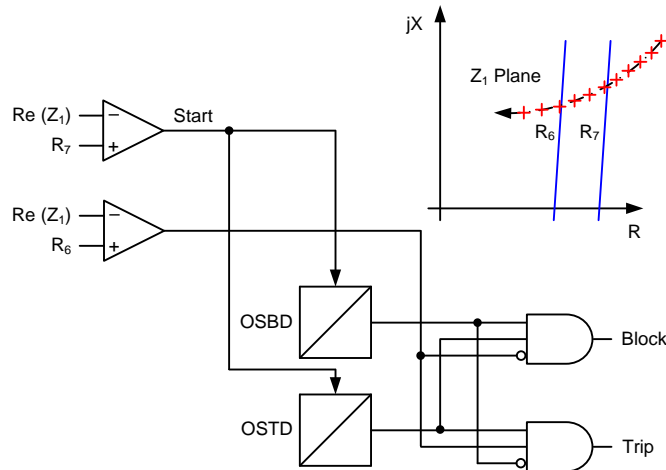
### ***Conventional OST Schemes***

Conventional OST schemes are based on the rate of change of the measured positive-sequence impedance vector during a power swing. The OST function is designed to differentiate between a stable and an unstable power swing and, if the power swing is unstable, to send a tripping command at the appropriate time to trip the line breakers. Traditional OST schemes use distance characteristics similar to the PSB schemes shown in Figures 16, 17, and 18. OST schemes also use a timer to time how long it takes for the measured impedance to travel between the two concentric characteristics. If the timer expires before the measured impedance vector travels between the two characteristics, the relay declares the power swing as an unstable swing and issues a tripping signal. Voltage supervision will increase the security of the OST scheme.

Figure 18 shows the dual-quadrilateral characteristic used for the detection of power swings. When the positive-sequence impedance enters the outer zone, two OOS logic timers start (OSTD and OSBD). Figure 26 illustrates how these timers operate.

There are two methods to implement out-of-step tripping. The first method is to trip on the way in (TOWI) when the OSTD timer expires and the positive-sequence impedance enters the inner zone. The second method is to select to trip on the way out (TOWO) when the OSTD timer expires and the positive-sequence impedance enters and then exits the inner zone. TOWO has the advantage of tripping the breaker at a more favorable time during the slip cycle when the two systems are close to an in-phase condition.

TOWI is necessary in some systems to prevent severe voltage dips and potential loss of loads. TOWI is typically applied in very large systems where the angular movement of one system with respect to another is very slow. It is also applied where there is a risk that transmission line thermal damage will occur if tripping is delayed until a more favorable angle exists between the two systems. However, it is necessary to evaluate potential trip conditions against the circuit breaker capability because the relay issues the tripping command to the circuit breaker when the relative phase angles of the two systems are approaching 180 degrees, which results in greater breaker stress than for OST applications that implement TOWO.



**Figure 26: Dual-Quadrilateral Timer Scheme**

One of the most important and difficult aspects of an OST scheme is the calculation of proper settings for the distance relay OST characteristics and the OST time-delay setting. Detailed dynamic simulation studies are recommended for cases where a transmission separation scheme is being developed for a specific disturbance scenario. These simulation studies can be used to address issues such as the maximum recoverable swing impedance and the adverse impact of the transient voltage dips associated with the swing. In some cases out of step settings may involve a tradeoff between minimizing transient voltage dips and avoid separation for recoverable swings.

The other difficult aspect of OST schemes is determining the appropriate time at which to issue a trip signal to the line breakers to avoid equipment damage and ensure personnel safety. To adequately protect the circuit breakers and ensure personnel safety, it may be necessary to prevent uncontrolled tripping during an OOS condition by restricting operation of the OST function to relative voltage angles between the two systems within the circuit breaker capability. Logic is included to allow delayed OST on the way out to minimize the possibility of breaker damage.

***Non-conventional OST Schemes***

The previously discussed OST setting complexities and the need for stability studies can be eliminated if the OST function is supervised by the output of a robust PSB function that makes certain that the network is experiencing a power swing and not a fault [4]. Using a reliable bit from the SCV PSB function for example to supervise an SCV-assisted OST function allows the implementation of a TOWO OST scheme without the need to perform any stability studies, which is a major advantage over traditional OST schemes.

The SCV-assisted OST function tracks and verifies that the measured  $Z_1$  impedance trajectory crosses the complex impedance plane from right to left, or from left to right, and issues a TOWO at a desired phase angle difference between sources. Verifying that the  $Z_1$  impedance enters the complex impedance plane from the left or right side and making sure it exits at the opposite side of the complex impedance plane ensures that the function operates only for unstable power swings. On the contrary, traditional OST schemes that do not track the  $Z_1$  impedance throughout the complex impedance plane may operate for a stable swing that was not considered during stability studies and happens to cross the inner OST characteristic.

Four resistive and four reactive blinders are still used in the SCV-assisted OST scheme, as shown in Figure 18. However, the settings for these blinders are easy to calculate when applying TOWO. The outermost OST resistive blinders can be placed around 80 to 90 degrees in the complex impedance plane, regardless of whether a stable power swing crosses these blinders or whether the load impedance of a long, heavily loaded line encroaches upon them. The inner OST resistive blinder can be set anywhere from 120 to 150 degrees. In addition, there are no OST timer settings involved in the SCV-assisted OST scheme.

To apply TOWI, stability studies are still required to ensure that no stable swings will cause the operation of the inner OST characteristic.

## Issues Associated With the Concentric or Dual-Blinder Methods

### *Impact of System Impedances*

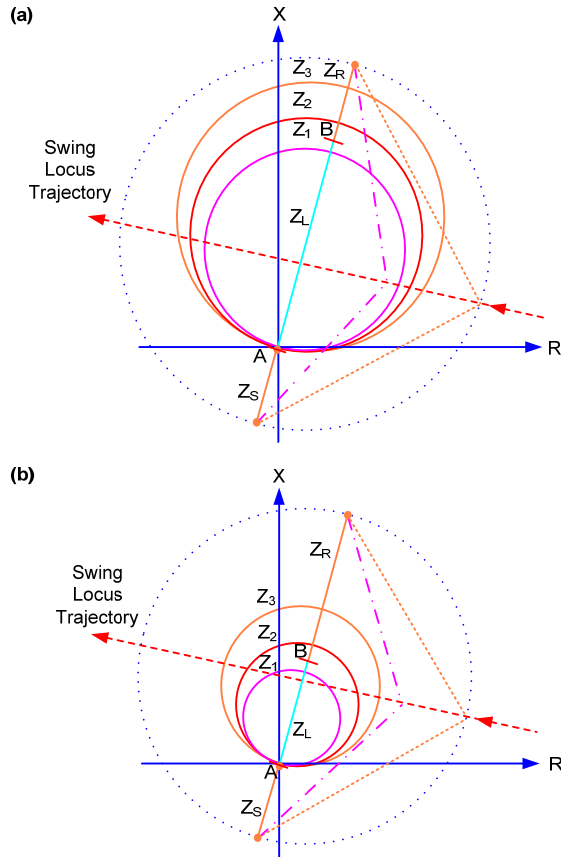
To guarantee enough time to carry out blocking of the distance elements after a power swing is detected, the inner impedance of the blinder element must be placed outside the largest distance element for which blocking is required. In addition, the outer blinder impedance element should be placed away from the load region to prevent PSB logic operation caused by heavy loads, thus establishing an incorrect blocking of the line mho tripping elements. The previous requirements are difficult to achieve in some applications, depending on the relative line impedance and source impedance magnitudes (see Figure 27).

Figure 27a depicts a system in which the line impedance is large compared with system impedances (strong source), and Figure 27b depicts a system in which the line impedance is much smaller than the system impedances (weak source).

We can observe from Figure 27a that the swing locus could enter the zone 2 and zone 1 relay characteristics during a stable power swing from which the system could recover. For this particular system, it may be difficult to set the inner and outer PSB blinder elements, especially if the line is heavily loaded, because the necessary PSB settings are so large that the load impedance could establish incorrect blocking. To avoid incorrect blocking resulting from load, lenticular distance relay characteristics, load encroachment, or blinders that restrict the tripping area of the mho elements have been applied in the past. On the other hand, the system shown in Figure 27b becomes unstable before the swing locus enters the zone 2 and zone 1 mho elements, and it is relatively easy to set the inner and outer PSB blinder elements.

Another difficulty with the blinder characteristic method is the separation between the inner and outer PSB blinder elements and the timer setting that is used to differentiate a fault from a power swing. These settings are not difficult to calculate, but depending on the system under consideration, it may be necessary to run extensive stability studies to determine the fastest power swing and the proper PSB blinder element settings. The rate of slip between two systems is a function of the accelerating torque and system inertias. In general, a relay cannot determine the slip analytically because of the complexity of the power system. However, by performing system stability studies and analyzing the angular excursions of systems as a function of time, it is possible to estimate an average slip in degrees per second or cycles per second. This approach may be appropriate for systems where slip frequency does not change considerably as the systems go out of step. However, in many systems where the slip frequency increases considerably after the first slip cycle and on subsequent slip cycles, a fixed impedance separation between the blinder PSB elements and a fixed time delay may not be suitable to provide a continuous blocking signal to the mho distance elements.

In a complex power system, it is very difficult to obtain the proper source impedances that are necessary to establish the blinder and PSB delay timer settings [3]. The source impedances vary continuously according to network changes, such as additions of new generation and other system elements. The source impedances could also change drastically during a major disturbance and at a time when the PSB and OST functions are called upon to take the proper actions. Normally, very detailed system stability studies are necessary to consider all contingency conditions in determining the most suitable equivalent source impedance to set the PSB or OST functions.



**Figure 27: Effects of Source and Line Impedances on the PSB Function**

***Impact of Heavy Load on the Resistive Settings of the Quadrilateral Element***

References [3] and [4] recommend setting the concentric dual-quadrilateral power swing characteristic inside the maximum load condition but outside the maximum distance element reach desired to be blocked. In long-line applications with a heavy load flow, following these settings guidelines may be difficult, if not impossible. Fortunately, most numerical distance relays allow some form of programming capability to address these special cases. However, in order to set the relay correctly, stability studies are required; a simple impedance-based solution is not possible.

The approach for this application is to set the power swing blinder such that it is inside the maximum load flow impedance and the worst-case power swing impedance. Using this approach can result in cutting off part of the distance element characteristic. Reference [11] provides additional information and logic to address the issues of PSB settings on heavily loaded transmission lines.

**OOS Relaying Philosophy**

There are many different power swing detection methods that can be used to protect a power system from OOS conditions, each of which has its own benefits and drawbacks. While the OOS relaying philosophy is simple, it is often difficult to implement in a large power system because of the complexity of the system and the different operating conditions that must be studied.

The recommended approach for OOS relaying application is summarized below:

- Perform system transient stability studies to identify system stability constraints based on many operating conditions and stressed-system operating scenarios. The stability studies will help identify the parts of the power system that impose limits to angular stability, generators that are prone to go OOS during system disturbances, and those that remain stable. The results of stability studies are also used to identify the optimal location of OST and PSB protection relay systems.

- Determine the locations of the swing loci during various system conditions and identify the optimal locations to implement the OST protection function. The optimal location for the detection of the OOS condition is near the electrical center of the power system. However, it is necessary to determine that the behavior of the impedance locus near the electrical center would facilitate the successful detection of OOS.
- Determine the optimal location for system separation during an OOS condition. This will typically depend on the impedance between islands, the potential to attain a good load/generation balance, and the ability to establish stable operating areas after separation. High impedance paths between system areas typically represent appropriate locations for network separation.
- Establish the maximum rate of slip between systems for OOS timer setting requirements, as well as the minimum forward and reverse reach settings required for successful detection of OOS conditions. The swing frequency of a particular power system area or group of generators relative to another power system area or group of generators does not remain constant. The dynamic response of generator control systems, such as automatic voltage regulators, and the dynamic behavior of loads or other power system devices, such as SVCs and FACTS, can influence the rate of change of the impedance measured by OOS protection devices.

## References

- [1] C. R. Mason, *The Art and Science of Protective Relaying*. John Wiley & Sons, Inc., New York, 1956.
- [2] G. Benmouyal, D. Hou, and D. Tziouvaras, "Zero-setting Power-Swing Blocking Protection ", proceedings of the 31st Annual Western Protective Relay Conference, Spokane, WA, October 2004.
- [3] D. Tziouvaras, and D. Hou, "Out-of-Step Protection Fundamentals and Advancements," proceedings of the 30th Annual Western Protective Relay Conference, Spokane, WA, October 2003.
- [4] N. Fischer, G. Benmouyal, Da. Hou, D. Tziouvaras, J. Byrne-Finley, and B. Smyth, "Tutorial on Power Swing Blocking and Out-of-Step Tripping," proceedings of the 39th Annual Western Protective Relay Conference, Spokane, WA, October 2012.
- [5] J. Holbach, "New Blocking Algorithm for Detecting Fast Power Swing Frequencies," proceedings of the 30th Annual Western Protective Relay Conference, Spokane, WA, October 2003.
- [6] Q. Verzosa, "Realistic Testing of Power Swing Blocking and Out-of-Step Tripping Functions," proceedings of the 38th Annual Western Protective Relay Conference, Spokane, WA, October 2011.
- [7] C. W. Taylor, J. M. Haner, L. A. Hill, W. A. Mittelstadt, and R. L. Cresap, "A New Out-of-Step Relay With Rate of Change of Apparent Resistance Augmentation," *IEEE Transactions on Power Apparatus and Systems*, Vol. PAS-102, No. 3, March 1983.
- [8] J. M. Haner, T. D. Laughlin, and C. W. Taylor, "Experience with the R Rdot Out-of-Step Relay," *IEEE Transactions on Power Delivery*, Vol. 1, No. 2, April 1986.
- [9] F. Ilar, "Innovations in the Detection of Power Swings in Electrical Networks," Brown Boveri Publication CH-ES 35-30.10E, 1997.
- [10] A. Guzmán, V. Mynam, and G. Zweigle, "Backup Transmission Line Protection for Ground Faults and Power Swing Detection Using Synchrophasors," proceedings of the 34th Annual Western Protective Relay Conference, Spokane, WA, October 2007.
- [11] J. Mooney and N. Fischer, "Application Guidelines for Power Swing Detection on Transmission Systems," proceedings of the 32nd Annual Western Protective Relay Conference, Spokane, WA, October 2005.
- [12] W. A. Elmore, "The Fundamentals of Out-of-Step Relaying," proceedings of the 34th Annual Conference for Protective Relay Engineers, Texas A&M University, College Station, TX, April 1981.
- [13] IEEE Power System Relaying Committee, Working Group D-6 Report, *Power Swing and Out-of-Step Considerations on Transmission Lines*. Available: <http://www.pes-psrc.org/>.

## Appendix D – Potential Methods to Demonstrate Security of Protective Relays

---

### IEEE PSRC WG D6 Method

Appendix A of the IEEE PSRC WG D6 paper on power swing considerations presents the process of reducing a complex power system to a two source equivalent system connected by a single transmission line in parallel with a second line which is the equivalent of the remaining transmission system connecting the two sources. The two source equivalent system will be accurate for faults anywhere on the retained transmission line. It can also be used to determine whether the swing center of the two systems lies within the retained transmission. The usefulness of the method of determining whether the swing center is contained within the line depends on the probability of the actual power system to consist of two coherent systems of generators connected by the modeled system.

This method was applied to a system in the northwest portion of the eastern interconnection. The system consists of a double circuit ring of 345 kV lines around an underlying 115 kV system. Large generation stations are located at several points around the ring. The 345 kV lines connect with other systems from the east, southeast, and southwest parts of the ring. When applied to these connections, the method of Appendix A predicts that the swing center will pass through these lines. In fact this system has been observed to have at least one of these swing centers, and the system of generators around the ring will behave as a coherent set relative to the connected system across the ties.

The method also predicts that virtually every 115kV line within the 345kV ring will also contain the swing center when the system is reduced to a two source equivalent. It is extremely unlikely to separate into two independent sets of coherent generators within this ring. In his paper “The Fundamentals of Out-Of-Step Relaying”, Walt Elmore presents this method and states, “When more than a line or two are to be analyzed, it is virtually impossible to use the method.”

When applied to the 345kV lines making up the double circuit ring, the method shows that for a majority of them the swing center will not pass through them, but will fall just outside the line. For the most part, these lines are fairly short with many interconnections. An assessment was not performed examining the effect of taking two or three lines out, but this likely would result in bringing the center into one end of the line. With several of these lines out the possibility of two sets of generators swinging relative to each other increases.

For the most part, the Appendix A method looks useful for identifying swing centers between relatively independent systems connected by a small number of ties.

### Calculation Methods based on the Graphical Analysis Method

A classical method to determine if a particular relay is subject to tripping during a power swing is discussed in Appendix A. In this method, the system consists of the line where the relay is applied with a system equivalent generator and impedance at each end of a particular line (see Figure 6). For this system, assuming equal voltage magnitudes for the equivalent generator, a power swing traverses along the perpendicular bisector of the total system impedance. Figure 6 shows a graphical interpretation of this. In Figure 7, the dashed line is the path the impedance traverses during the power swing and the angle  $\delta$  is the angle between the two equivalent generator sources. The impedance seen at relay terminal A is to the right of the relay's impedance characteristic prior to the onset of the power swing. As a stable power swing occurs, the angle between the two equivalent generators increases causing the impedance to move to the left along the dashed line. When the system stabilizes, the power swing will switch directions (this can take a significant amount of time) and move to the right along the dashed line, oscillate, and then end at a new stable operating point. Depending on the size of the overall system impedance, the length of the line, and the reach of the impedance relay, the stable power swing may or may not fall within the relay characteristic. For cases where the relay's impedance characteristic intersects the electrical center of the system, the power swing will enter the relay's characteristic at some value of the angle  $\delta$ . When the power swing enters the relay's characteristic, the relay will trip quickly if it is a zone 1 type relay. Because stable power swings may be slower to reverse direction than it takes a typical time delayed relay to trip, time delayed zones must also be evaluated.

As stated in this report and many others it is generally accepted based on many power swing studies that if a power swing traverses beyond an angle  $\delta$  greater than or equal to 120 degrees, the power swing will not be stable. This 120 degree angle is often called the “critical angle.” The logic behind the general acceptance of 120 degrees as the critical angle for

stability is discussed above in Appendix A. Two potential methods are presented to screen relays for susceptibility to stable power swings based on the use of the 120 degree critical angle.

### Method 1

The first method uses an equivalent circuit based on the system shown in Figure 28. A calculation is made of the impedance seen at a relay terminal when the difference between the generator angles in the equivalent system described above is 120 degrees. If the impedance calculated does not fall within the relays impedance characteristic, it is not susceptible to tripping for a stable power swing. The discussion that follows pertains to a mho type relay characteristic, but the same process could be used for other characteristics.

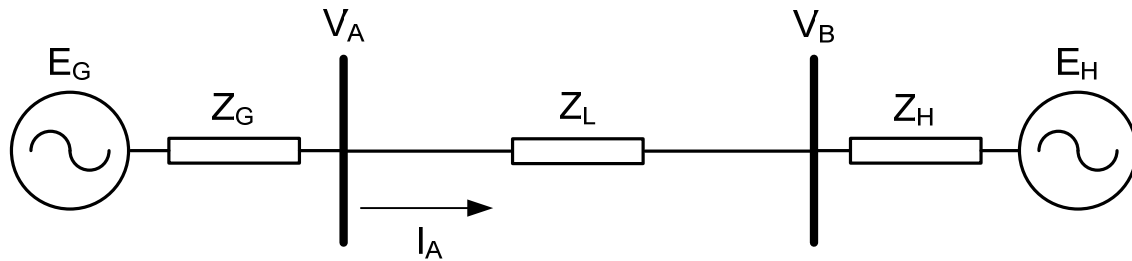


Figure 28: Two-Machine Equivalent of a Power System

Since this calculation does not use a computer model, various parameters must be established:

- It is a reasonable and conservative assumption to assume that the voltage at the equivalent generator terminals is 1.05 per unit even under these severe conditions.
- The angle between the generator voltages is set to the 120 degree critical angle.
- Line and equivalent generator impedance angles are set to 90 degrees. This causes minimal variation in the calculation and simplifies the calculation.
- The equivalent generator impedances can be calculated using a fault study program and calculated with the line under study out of service.

Given these parameters the allowable impedance for the relay (circular mho type) at terminal A can be calculated as follows. Referring to Figure 28:

$$V_A = E_G - I_A * Z_G \text{ and}$$

$$I_A = (E_G - E_H) / (Z_G + Z_L + Z_H) \text{ and}$$

$$Z_A = V_A / I_A = Z_{AMAG} @ Z_{Aang} \text{ and}$$

$$Z_{Aallowable} = Z_{AMAG} / (\cos(MTA - Z_{Aang}))$$

Similarly, the  $Z_{allowable}$  at the B terminal can be calculated:

$$V_B = E_H - I_H * Z_H \text{ and}$$

$$I_B = -I_A$$

$$Z_B = V_B / I_B = Z_{BMAG} @ Z_{Bang} \text{ and}$$

$$Z_{Ballowable} = Z_{BMAG} / (\cos(MTA - Z_{Bang}))$$

An example of some  $Z_{allowable}$  calculations using this method for a 345kV system is shown below:



**Table 1: Examples of  $Z_{\text{allowable}}$  for a Sample 345 kV System Using Method 1**

System Angle (degrees)		System and Line Impedance (Ohms)			$Z_{\text{A allowable}}$				$Z_{\text{B allowable}}$			
$E_{\text{G}}$	$E_{\text{H}}$	$Z_{\text{G}}$	$Z_{\text{L}}$	$Z_{\text{H}}$	90° MTA	85° MTA	80° MTA	75° MTA	90° MTA	85° MTA	80° MTA	75° MTA
0	120	5	5	10	11.7	13.0	14.9	17.5	11.7	10.6	9.8	9.2
0	120	13	5	10	66.3	227.4	-158.4	-58.9	16.3	15.1	14.3	13.6
0	120	20	20	10	46.7	62.7	96.5	213.3	46.7	37.4	31.4	27.2
0	120	5	5	60	43.6	46.5	50.3	55.1	43.6	41.3	39.6	38.2

Note 1) A negative number means that no stable power swings will fall within the zone.

Note 2) If  $E_{\text{G}} = 120$  and  $E_{\text{H}} = 0$ , then the  $Z_{\text{A}}$  allowable impedances shown become the  $Z_{\text{B}}$  allowable impedances and vice versa.

This method is conservative for a number of reasons:

- This simplified calculation assumes a large stable power swing with the system in a normal configuration. Tripping for a stable power swing is more likely with the system weakened. Weakening the system increases the allowable impedance for a given line.
- This simplified calculation estimates the equivalent system impedances from the fault model which uses sub-transient reactances for generators. Power Swings are longer time phenomena and use transient reactances which are larger ( $X''_{\text{d}} \sim 0.7X'_{\text{d}}$ ).
- It does not include the effects of parallel paths to the line under test (i.e., it ignores the transfer impedance – see Method 2). Including parallel paths allows for a higher distance zone setting. This method essentially assumes that the line under test is the only line connecting two systems.

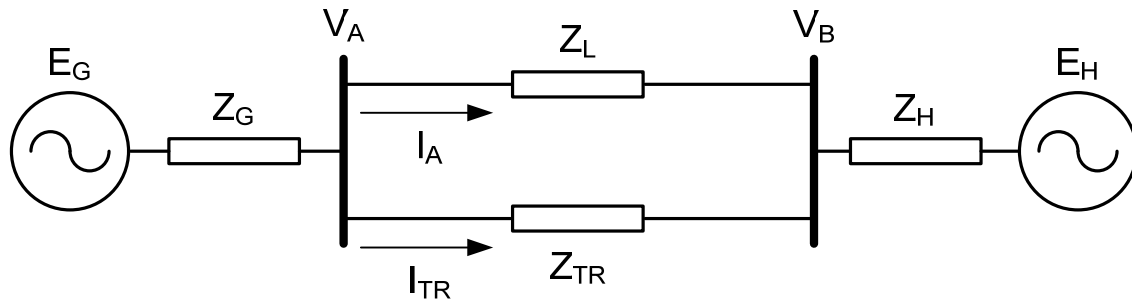
Some conclusions that are generally known can also be drawn from this method:

- Shorter lines with shorter relay settings are less susceptible to tripping on power swings than longer lines with larger settings.
- Zone 1 relays on short lines (i.e. lines  $< \sim 40$  miles at 345kV and probably greater) are basically immune to tripping on stable power swings. Overreaching distance zones (zone 2, zone 3, etc.) with reaches equivalent to this short line zone 1 reach are also basically immune to tripping on stable power swings. Note that distances vary proportionally with voltage level (lower at lower voltages and higher at higher voltage levels).
- As source impedances change due to system configuration changes, the susceptibility of a mho relay to trip for a stable power swing can vary a great deal.
- Depending on the direction of power flow during the stable swing (into or out of the relay terminal), the susceptibility of a mho relay to trip for a stable power swing can vary a great deal.
- This method will screen out backup zones in some cases, but does not screen out backup zones well, even on highly connected systems where stable power swings are less likely or highly unlikely.

## Method 2

The second method uses an equivalent circuit based on the system shown in Figure 29. A calculation of the impedance seen at a relay terminal when the difference between the generator angles in the equivalent system described above is 120

degrees is made. If the impedance calculated does not fall within the relays impedance characteristic, it is not susceptible to tripping for a stable power swing. The discussion that follows pertains to a mho type relay characteristic, but the same process could be used for other characteristics.



**Figure 29: Two-Machine Equivalent of a Power System with Parallel System Transfer Impedance**

Since this calculation does not use a computer model, various parameters must be established:

- It is a reasonable and conservative assumption to assume that the voltage at the equivalent generator terminals is 1.05 per unit even under these severe conditions.
- The angle between the generator voltages is set to the 120 degree critical angle.
- Line and equivalent generator impedance angles are set to 90 degrees. This causes minimal variation in the calculation and simplifies the calculation.
- The equivalent generator impedances and transfer impedances can be obtained from a fault study program.

Given these parameters the allowable impedance for the relay (circular mho type) at terminal A can be calculated as follows. Referring to Figure 29:

$$V_A = E_G - I_{TOTAL} * Z_G \text{ and}$$

$$I_{TOTAL} = (E_G - E_H) / (Z_G + Z_{eq} + Z_H) \text{ where } Z_{eq} = (Z_L * Z_{TR}) / (Z_L + Z_{TR}) \text{ and}$$

$$I_A = I_{TOTAL} * (Z_{TR} / (Z_{TR} + Z_L))$$

$$Z_A = V_A / I_A = Z_{AMAG} @ Z_{Aang} \text{ and}$$

$$Z_{Aallowable} = Z_{AMAG} / (\cos(MTA - Z_{Aang}))$$

Similarly, the Zallowable at the B terminal can be calculated:

$$V_B = E_H - I_H * Z_H \text{ and}$$

$$I_B = -I_A$$

$$Z_B = V_B / I_B = Z_{BMAG} @ Z_{Bang} \text{ and}$$

$$Z_{Ballowable} = Z_{BMAG} / (\cos(MTA - Z_{Bang}))$$

An example of some Zallowable calculations using this method for a 345kV system is shown below:

**Table 2: Examples of  $Z_{\text{allowable}}$  for a Sample 345 kV System Using Method 2**

System Angles		System, Line, and Transfer Impedances				$Z_{\text{A allowable}}$				$Z_{\text{B allowable}}$			
$E_{\text{G}}$	$E_{\text{H}}$	$Z_{\text{G}}$	$Z_{\text{H}}$	$Z_{\text{TR}}$	$Z_{\text{L}}$	90° MTA	85° MTA	80° MTA	75° MTA	90° MTA	85° MTA	80° MTA	75° MTA
0	120	5	5	10	10	20.0	23.7	29.2	38.6	17.5	16.3	15.4	14.7
0	120	5	5	50	10	13.1	14.8	17.1	20.5	12.7	11.7	10.9	10.3
0	120	5	5	100	10	12.4	13.9	16.0	18.9	12.2	11.2	10.4	9.7
0	120	5	5	500	10	11.8	13.2	15.1	17.8	11.8	10.7	9.9	9.3
0	120	13	5	10	10	-61.8	-44.7	-35.2	-29.3	27.8	26.2	25.0	24.0
0	120	13	5	50	10	416.3	-139.7	-60.0	-38.4	18.5	17.3	16.4	15.6
0	120	13	5	100	10	123.9	-489.1	-82.4	-45.2	17.4	16.2	15.3	14.6
0	120	20	20	10	10	140.0	257.7	1696.9	-369.5	52.0	47.8	44.6	42.1
0	120	20	20	50	10	61.1	86.7	151.4	615.4	40.1	34.7	30.7	27.7
0	120	20	20	100	10	53.6	74.0	120.9	337.1	41.7	35.0	30.4	27.0
0	120	5	5	10	60	76.9	86.7	100.2	119.8	83.5	79.4	76.3	74.0
0	120	5	5	50	60	48.7	52.5	57.4	63.9	51.6	48.9	46.9	45.4
0	120	5	5	100	60	46.0	49.4	53.7	59.3	47.6	45.1	43.2	41.8

Note 1) A negative number means that no stable power swings will fall within the zone.

Note 2) If  $E_{\text{G}} = 120$  and  $E_{\text{H}} = 0$ , then the  $Z_{\text{A}}$  allowable impedances shown become the  $Z_{\text{B}}$  allowable impedances and vice versa.

This method is conservative for a number of reasons:

- This simplified calculation assumes a large stable power swing with the system in a normal configuration. Tripping for a stable power swing is more likely with the system weakened. Weakening the system increases the allowable impedance for a given line.
- This simplified calculation estimates the equivalent system impedances from the fault model which uses sub-transient reactances for generators. Power Swings are longer time phenomena and use transient reactances which are larger ( $X''_d \sim 0.7X'_d$ ).

Some conclusions that are generally known can also be drawn from this method:

- If the transfer impedance is high, this method is essentially the same as method 1. If the transfer impedance is infinite, this method is equivalent to method 1.

- If the transfer impedance is low as in a more interconnected system, this method shows that a greater relay reach can be set before a relay will trip during a stable power swing versus method 1. This method is a more accurate representation of the power system and hence is more accurate than method 1. However, as transfer impedances change due to system configuration changes, the susceptibility of a mho relay to trip for a stable power swing also changes.
- Shorter lines with shorter relay settings are less susceptible to tripping on power swings than longer lines with larger settings.
- Zone 1 relays on short lines (i.e. lines < ~ 40 miles at 345kV and probably greater) are basically immune to tripping on stable power swings. Overreaching distance zones (zone 2, zone 3, etc.) with reaches equivalent to this short line zone 1 reach are also basically immune to tripping on stable power swings. Note that distances vary with voltage level (lower at lower voltages and higher at higher voltage levels).
- As source impedances change due to system configuration changes, the susceptibility of a mho relay to trip for a stable power swing can vary a great deal.
- Depending on the direction of power flow during the stable swing (into or out of the relay terminal), the susceptibility of a mho relay to trip for a stable power swing can vary a great deal.
- This method will screen out backup zones better than method 1.

Like the methods for loadability in PRC-023, both method 1 and method 2 address a single impedance relay or a single relay element. This method does not provide a calculation for a composite scheme like a Permissive Overreach with Transfer Trip scheme where two relays may be required to pick up to cause a trip.

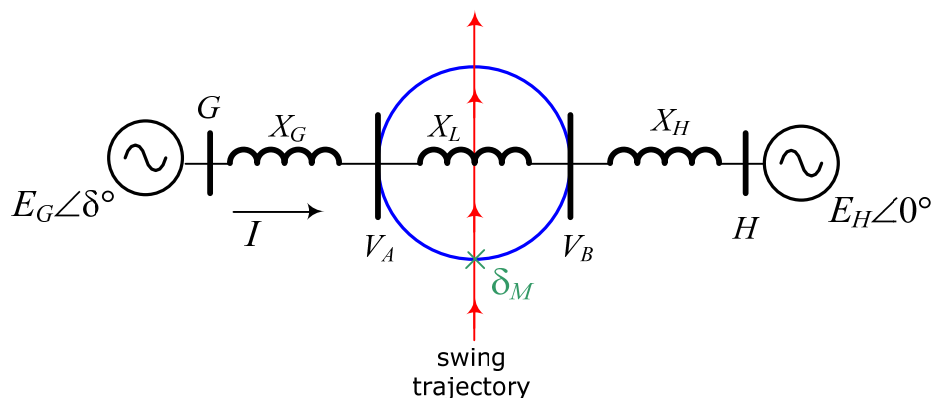
## Voltage Dip Screening Method

Although there are number of successful power swing detection methods, the goal of the voltage dip method is to establish a reliable screening tool easily applicable in transient stability planning studies. Transient stability planning studies evaluate many contingencies and monitor performance of many variables of the Bulk-Power System in order to demonstrate compliance with applicable standards and criteria. Due to the comprehensive nature of the analysis, a practical screening method that flags potential power swing problems is essential.

It is well known that the most accurate method of identifying stable/unstable power swing requires a model of the protection system (susceptible to stable and unstable power swings) in place and detailed simulation of the event that produces the power swing. A plot of apparent impedance trajectory during the system disturbance against an appropriate relay characteristic determines the power swing status. In large scale transient stability planning studies where many contingencies are considered, that approach requires an effort of modeling and maintaining many relay characteristics and recording many apparent impedance channels. The proposed screening method seeks a reliable way of identifying potential power swings with minimal burden on additional modeling as part of the analysis.

While the power swing is the result of angular separation between units or coherent groups of units that oscillate against each other, finding the coherent groups requires multiple simulation runs. In power swing identification primary question is whether the swing is stable or not and the subsequent question is to identify which units drive the power swing. As a result of coherent units swings, the transmission voltage magnitude gets low near the center of the swing. Therefore, since transmission voltages are monitored in transient stability planning studies and voltage performance is subject to planning criteria in many areas (WECC Transmission planning standard and ISO-NE voltage sag guidelines), post-disturbance voltage dips can be used as a potential screening tool for power swing identification.

In order to establish a theory behind the proposed method, a two-source equivalent is examined first. Since the system has only one path between two sources, the idea is to study a range of system conditions subject to the power swing and then test the voltage dip criteria on the transmission line terminals. The two-source system in Figure 30 is analyzed. The system is assumed to be symmetrical (i.e., the source terminal voltages are equal in magnitude,  $|E_G|=|E_H|$ ), during the power swing, the electrical center occurs in the middle of the impedance between two sources.


**Figure 30: Two-source equivalent system**

The following assumptions have been made regarding the system in Figure 30:

- 1) Source and line resistances are neglected
- 2) Distance relay characteristic is a circle with diameter equal to 100 percent of line reactance
- 3) Relay maximum torque angle is equal to line angle
- 4) For simplicity it will be assumed that  $X_G + X_L + X_H = 1$  pu
- 5) Source voltage magnitudes are equal  $E_G = E_H = 1.0$  pu
- 6)  $E_H \angle 0^\circ$ , represents an infinite bus
- 7)  $E_G \angle \delta^\circ$ , with  $\delta \in (0^\circ, 180^\circ)$  swings against  $E_H$
- 8) Angle  $\delta_M$  represents angle of separation between sources G and H at which swing trajectory enters line relay characteristic.

The equations used in numerical simulations of the system represented in Figure 30 are as follows.

The current between two sources is determined by:

$$I = \frac{E_G \angle \delta - E_H \angle 0}{j(X_G + X_L + X_H)}$$

The voltage at the electrical center of the swing is:

$$V_C = E_G - j \frac{X_G + X_L + X_H}{2} I$$

The complex voltages at the line ends A and B are:

$$V_A = E_G - jX_G I$$

$$V_B = E_H + jX_H I$$

The goal of the following analysis is that depending on different system conditions in terms of strength of systems and length of the line, investigate values of different quantities of the two source system at the moment when power swing locus enters the line relay characteristic (designated with angle  $\delta_M$  in Figure 30) and test whether power swing could be identified based on voltage dip at the line terminals.

Following system conditions are investigated.

- 1) Case 1: two strong systems connected with long line (i.e.,  $X_G = X_H = 0.1$  pu and  $X_L = 0.8$  pu)
- 2) Case 2: two weak systems connected with long line ( $X_G = X_H = 0.3$  pu and  $X_L = 0.4$  pu)
- 3) Case 3: weak system G connected to strong system H with long line ( $X_G = 0.3$  pu,  $X_H = 0.1$  pu and  $X_L = 0.6$  pu)
- 4) Case 4: variation of case 3 with  $X_G = 0.4$  pu,  $X_H = 0.2$  pu and  $X_L = 0.4$  pu

Results of the analysis are summarized in Table 3 while power swing characteristics are plotted in Figures 31 and 32.

Table 3: Results										
Case	$X_G$ [pu]	$X_L$ [pu]	$X_H$ [pu]	$Zr \angle \delta$ [pu/deg]	$\delta_M$ [deg]	$V_C$ [pu]	$V_A$	$\delta_A$ [deg]	$V_B$	$\delta_B$ [deg]
1	0.1	0.8	0.1	0.639 $\angle$ 51.5	103	0.622	0.883	96.7	0.883	6.33
2	0.3	0.4	0.3	0.537 $\angle$ 68.5	137	0.366	0.522	113.9	0.522	23.06
3	0.3	0.6	0.1	0.572 $\angle$ 61	122	0.485	0.598	96.8	0.851	5.72
4	0.4	0.4	0.2	0.529 $\angle$ 71	142	0.326	0.376	101.2	0.654	10.85

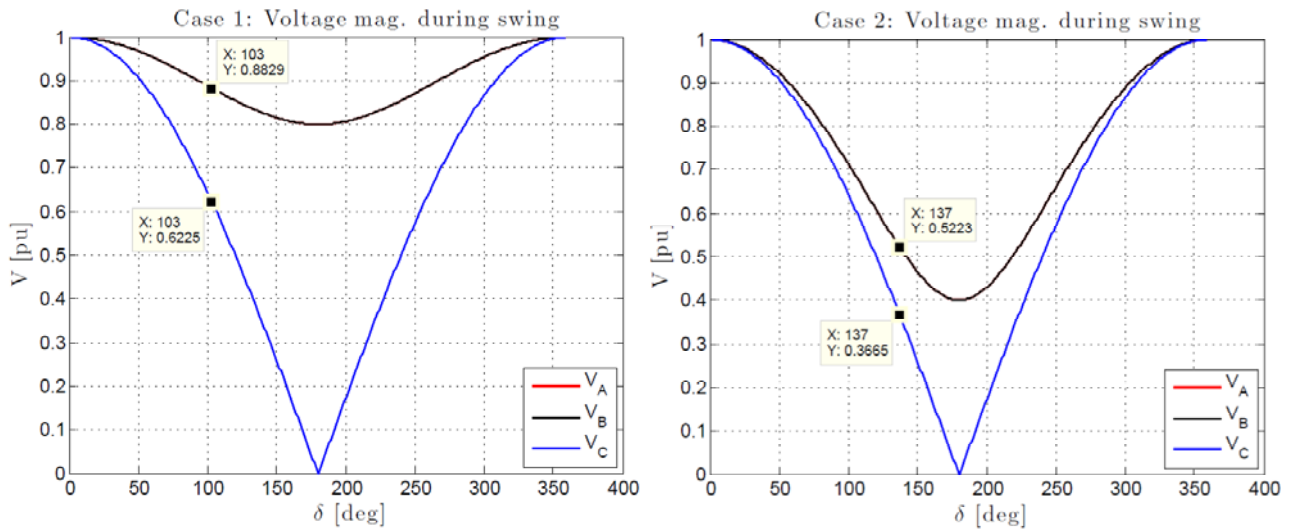


Figure 31: Case 1 and Case 2 Voltage Plots

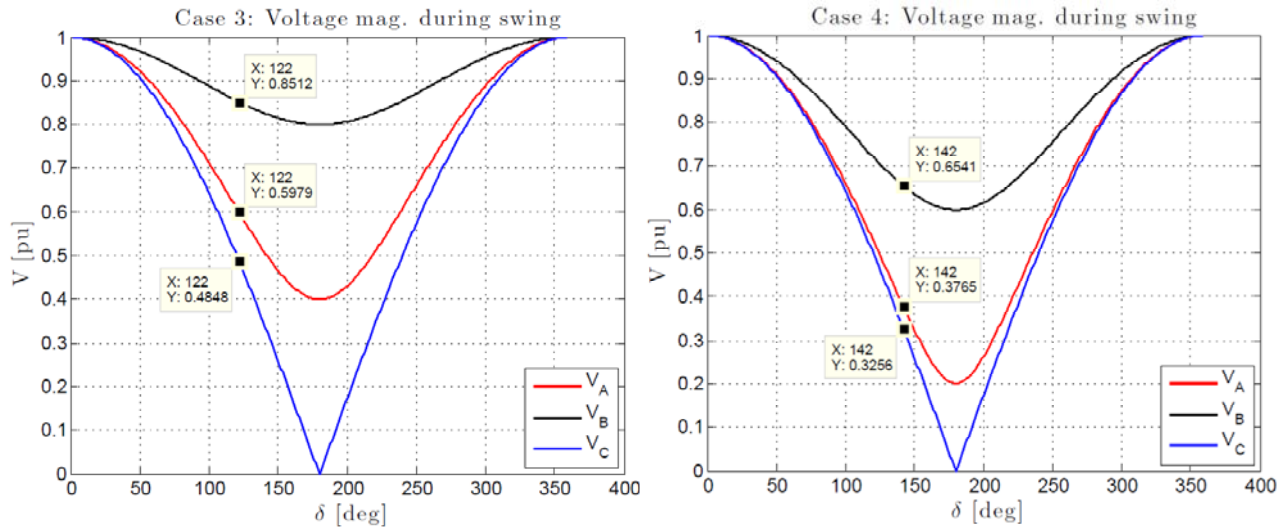


Figure 32: Case 3 and Case 4 Voltage Plots

### Discussion of the Results

Case 1: sets the minimal angle  $\delta_M$  at which power swing trajectory enters the line relay characteristic. Voltage magnitudes at line ends  $V_A$  and  $V_B$  are highest since they are electrically closer to sources than to the center of the swing. Figure 31a illustrates the voltage magnitude plot for this scenario.

Case 2: If the systems are weak (high source reactance) angle  $\delta_M$  increases and voltage magnitudes at the line end get lower (around 0.522 pu). The reason for lower line terminal voltages is its proximity to the electrical center of the swing. Fig. 30b represents voltage plot for case 2 scenario.

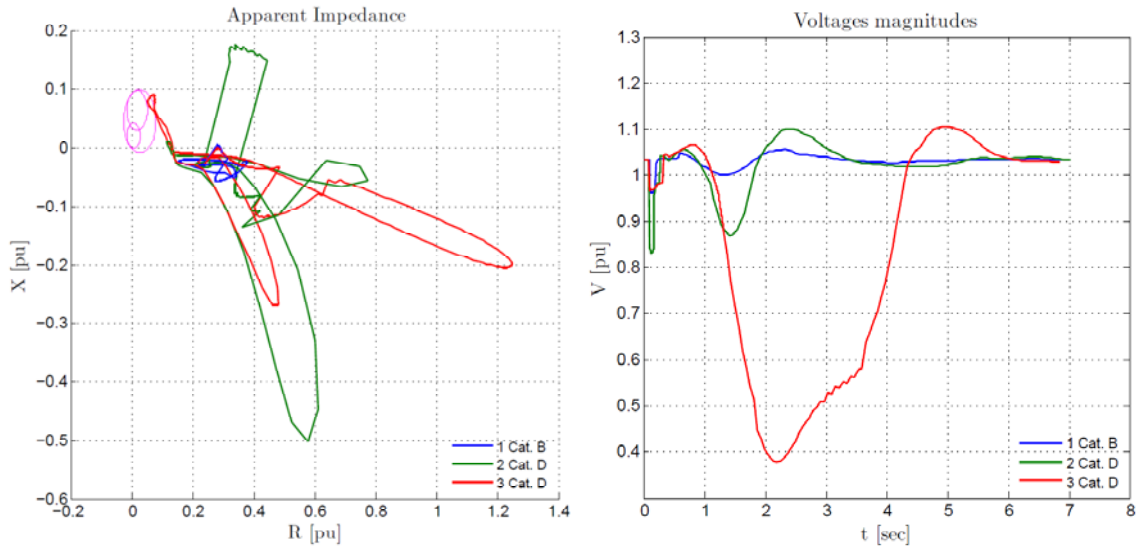
Case 3: This case represents a weak system G that swings against strong system H. Angle  $\delta_M$  is around  $120^\circ$  and the line end voltage  $V_A$  that is closer to electrical center of the swing is below 0.6 pu. Figure 32a represents voltage plot for case 3 scenario.

Case 4: This case presents variation of Case 3. The weaker is the system G (higher reactance  $X_G$ ) the higher is the angle at which power swing enters the line relay characteristic ( $\delta_M$ ) which makes it difficult to set  $120^\circ$  as a threshold for stable power swing detection. However, line terminal voltage closer to the electrical center gets very low;  $V_A = 0.376$  pu which makes it more reliable indicator for a swing. Figure 32b represents voltage plot for case 4 scenario.

The cases considered in two-source equivalent system indicate that voltage magnitude at the line terminal is a reliable indication of the power swing.

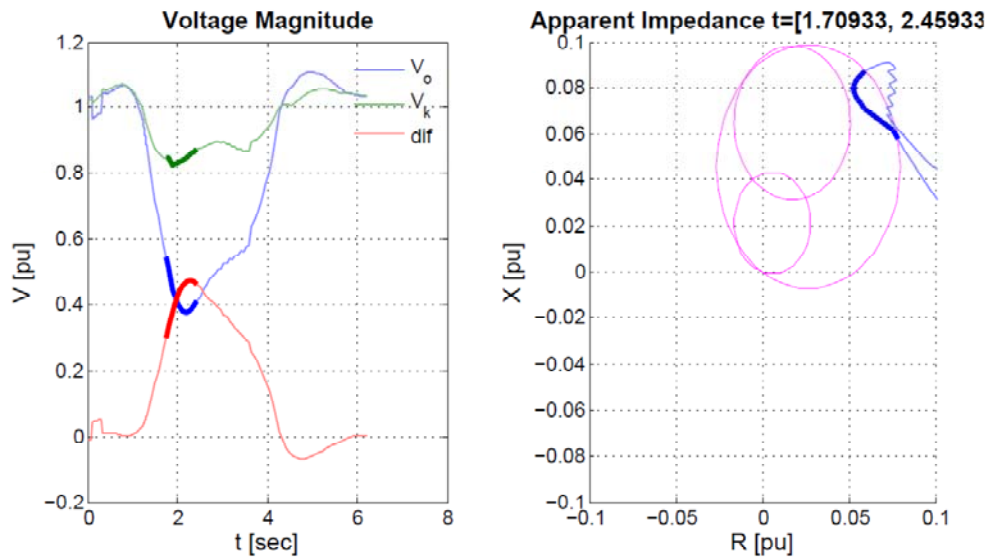
### Practical Power System Example

In order to make the proposed method practical for planning studies, and to establish potential voltage threshold for identification of stable power swings, a few transient stability simulation with a known stable power swing were performed. The first practical example is tested on New England’s bulk power system with three contingencies of increasing level of severity. Voltage at the one terminal of the line subject to power swing and apparent impedance recorded by the relay at the same line are monitored. Post disturbance apparent impedance and voltage magnitude performance for all three contingencies are presented in Figure 33.



**Figure 33: Apparent Impedance and Voltage Dip Plots**

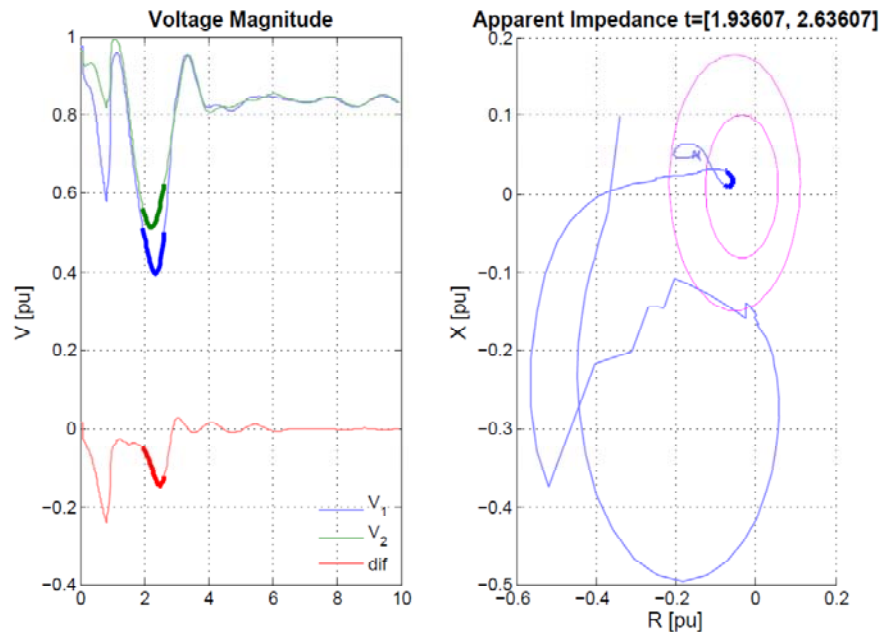
From Figure 34 one can notice a strong coupling between voltage dip and minimum apparent impedance. It is also of interest to confirm that the most severe contingency produces a stable power swing and the largest voltage dip. Since the apparent impedance plot is not time dependent, an additional analysis is performed to correlate minimum voltage dip with minimum apparent impedance during the power swing. Figure 34 presents such analysis with bold segments indicating quantities during the same time interval.



**Figure 34: Power Swing in the New England System**

The second example presented in Figure 35 is the stable power swing simulation results in the Florida system.





**Figure 35: Power Swing in the Florida System**

Analysis conducted on the New England and Florida systems suggest a few important conclusions.

- Apparent impedance and voltage magnitude are correlated, therefore for screening purposes in planning studies voltage magnitude can be used.
- Presented cases suggest that post disturbance voltage magnitude in the range of 0.5 and 0.6 pu might be used as a screening tool for power swing identification.
- Cases identified in the screening analysis require further detailed study.

Although theory and practice of the proposed voltage dip method are consistent, more test cases are needed in order to establish voltage dip threshold and applicable margin.

## Appendix E – System Protection and Control Subcommittee

---

**William J. Miller**

*Chair*  
Principal Engineer  
Exelon Corporation

**Philip B. Winston**

*Vice Chair*  
Chief Engineer, Protection and Control  
Southern Company

**Michael Putt**

*RE – FRCC*  
Manager, Protection and Control Engineering Applications  
Florida Power & Light Co.

**Mark Gutzmann**

*RE – MRO*  
Manager, System Protection Engineering  
Xcel Energy, Inc.

**Richard Quest**

*RE – MRO – Alternate*  
Principal Systems Protection Engineer  
Midwest Reliability Organization

**George Wegh**

*RE – NPCC*  
Manager – Transmission Protection and Controls Engineering  
Northeast Utilities

**Quoc Le**

*RE – NPCC -- Alternate*  
Manager, System Planning and Protection  
NPCC

**Jeff Iler**

*RE – RFC*  
Principal Engineer, Protection and Control Engineering  
American Electric Power

**Therron Wingard**

*RE – SERC*  
Principal Engineer  
Southern Company

**David Greene**

*RE – SERC -- Alternate*  
Reliability Engineer  
SERC Reliability Corporation

**Lynn Schroeder**

*RE – SPP*  
Manager, Substation Protection and Control  
Westar Energy

**Samuel Francis**

*RE – TRE*  
System Protection Specialist  
Oncor Electric Delivery

**David Penney, P.E.**

*RE – TRE – Alternate*  
Senior Reliability Engineer  
Texas Reliability Entity

**Baj Agrawal**

*RE – WECC*  
Principal Engineer  
Arizona Public Service Company

**Forrest Brock**

*Cooperative*  
Station Services Superintendent  
Western Farmers Electric Cooperative

**Miroslav Kostic**

*Federal/Provincial Utility*  
P&C Planning Manager, Transmission  
Hydro One Networks, Inc.

**Sungsoo Kim**

*Federal/Provincial Utility*  
Section Manager – Protections and Technical Compliance  
Ontario Power Generation Inc.

**Joe T. Uchiyama**

*Federal/Provincial Utility*  
Senior Electrical Engineer  
U.S. Bureau of Reclamation

**Daniel McNeely**

*Federal/Provincial Utility - Alternate*  
Engineer - System Protection and Analysis  
Tennessee Valley Authority

**Michael J. McDonald**

*Investor-Owned Utility*  
Principal Engineer, System Protection  
Ameren Services Company

**Jonathan Sykes**

*Investor-Owned Utility*  
Manager of System Protection  
Pacific Gas and Electric Company

**Charles W. Rogers**

*Transmission Dependent Utility*  
Principal Engineer  
Consumers Energy Co.

**Philip J. Tatro**

*NERC Staff Coordinator*  
Senior Performance and Analysis Engineer  
NERC

## Appendix F – System Analysis and Modeling Subcommittee

---

**John Simonelli**

*Chair*

Director - Operations Support Services  
ISO New England

**K. R Chakravarthi**

*Vice Chair*

Manager, Interconnection and Special Studies  
Southern Company Services, Inc.

**G Brantley Tillis, P.E.**

*RE – FRCC*

Manager, Transmission Planning Florida  
Progress Energy Florida

**Kiko Barredo**

*RE – FRCC – Alternate*

Manager, Bulk Transmission Planning  
Florida Power & Light Co.

**Thomas C. Mielnik**

*RE – MRO*

Manager Electric System Planning  
MidAmerican Energy Co.

**Salva R. Andiappan**

*RE – MRO – Alternate*

Manager - Modeling and Reliability Assessments  
Midwest Reliability Organization

**Donal Kidney**

*RE – NPCC*

Manager, System Compliance Program Implementation  
Northeast Power Coordinating Council

**Quoc Le**

*RE – NPCC -- Alternate*

Manager, System Planning and Protection  
NPCC

**Eric Mortenson, P.E.**

*Investor-Owned Utility*

Principal Rates & Regulatory Specialist  
Exelon Business Services Company

**Mark Byrd**

*RE – SERC*

Manager - Transmission Planning  
Progress Energy Carolinas

**Gary T Brownfield**

*RE – SERC – Alternate*

Supervising Engineer, Transmission Planning  
Ameren Services

**Jonathan E Hayes**

*RE – SPP*

Reliability Standards Development Engineer  
Southwest Power Pool, Inc.

**Kenneth A. Donohoo, P.E.**

*RE – TRE*

Director System Planning  
Oncor Electric Delivery

**Hari Singh, Ph.D.**

*RE – WECC*

Transmission Asset Management  
Xcel Energy, Inc.

**Kent Bolton**

*RE – WECC – Alternate*

Staff Engineer  
Western Electricity Coordinating Council

**Patricia E Metro**

*Cooperative*

Manager, Transmission and Reliability Standards  
National Rural Electric Cooperative Association

**Paul McCurley**

*Cooperative – Alternate*

Manager, Power Supply and Chief Engineer  
National Rural Electric Cooperative Association

**Ajay Garg**

*Federal/Provincial Utility*

Manager, Policy and Approvals  
Hydro One Networks, Inc.

**Amos Ang, P.E.**

*Investor-Owned Utility*

Engineer, Transmission Interconnection Planning  
Southern California Edison

**Bobby Jones**

*Investor-Owned Utility*

Project Manager, Stability Studies  
Southern Company Services, Inc.

**Scott M. Helyer**

*IPP*

Vice President, Transmission  
Tenaska, Inc.

**Digaunto Chatterjee**

*ISO/RTO*

Manager of Transmission Expansion Planning  
Midwest ISO, Inc.

**Bill Harm**

*ISO/RTO*

Senior Consultant  
PJM Interconnection, L.L.C.

**Steve Corey**

*ISO/RTO – Alternate*

Manager, Transmission Planning  
New York Independent System Operator

**Bob Cummings**

*NERC Staff Coordinator*

Senior Performance and Analysis Engineer  
NERC

## Appendix G – Additional Contributors

---

**John Ciuffo, P.Eng.**

Principal Engineer  
Ciuffo & Cooperberg Consulting, Inc.

**Tom Gentile**

Vice President Transmission  
Quanta Technology

**Bryan Gwyn**

Senior Director, Protection and Control Asset Management  
Quanta Technology

**Kevin W. Jones**

Principal Engineer, System Protection Engineering  
Xcel Energy

**Dmitry Kosterev**

Bonneville Power Administration

**Chuck Matthews**

Bonneville Power Administration

**John O'Connor**

Principal Engineer  
Progress Energy Carolinas

**Slobodan Pajic**

Senior Engineer, Energy Consulting  
GE Energy Management

**Fabio Rodriguez**

Principal Engineer  
Progress Energy Florida

**Tracy Rolstad**

Senior Power System Consultant  
Avista Corporation

**Joseph Seabrook**

Consulting Engineer  
Puget Sound Energy, Inc.

**Demetrios Tziouvaras**

Senior Research Engineer  
Schweitzer Engineering Laboratories, Inc.

**Exhibit F**

**Analysis of Violation Risk Factors and Violation Severity Levels**

# Violation Risk Factors and Violation Severity Level Justifications

Project 2010-13.3 – Relay Loadability: Stable Power Swings  
(PRC-026-1 – Relay Performance During Stable Power Swings)

## Violation Risk Factor and Violation Severity Level Justifications

This document provides the drafting team's justification for assignment of violation risk factors (VRFs) and violation severity levels (VSLs) for each requirement in: PRC-026-1 – Relay Performance During Stable Power Swings.

Each primary requirement is assigned a VRF and a set of one or more VSLs. These elements support the determination of an initial value range for the Base Penalty Amount regarding violations of requirements in FERC-approved Reliability Standards, as defined in the ERO Sanction Guidelines.

The Protection System Response to Power Swings Standard Drafting Team applied the following NERC criteria and FERC Guidelines when proposing VRFs and VSLs for the requirements under this project.

### **NERC Criteria - Violation Risk Factors**

#### ***High Risk Requirement***

A requirement that, if violated, could directly cause or contribute to bulk electric system instability, separation, or a cascading sequence of failures, or could place the bulk electric system at an unacceptable risk of instability, separation, or cascading failures; or, a requirement in a planning time frame that, if violated, could, under emergency, abnormal, or restorative conditions anticipated by the preparations, directly cause or contribute to bulk electric system instability, separation, or a cascading sequence of failures, or could place the bulk electric system at an unacceptable risk of instability, separation, or cascading failures, or could hinder restoration to a normal condition.

#### ***Medium Risk Requirement***

A requirement that, if violated, could directly affect the electrical state or the capability of the bulk electric system, or the ability to effectively monitor and control the bulk electric system. However, violation of a medium risk requirement is unlikely to lead to bulk electric system instability, separation, or cascading failures; or, a requirement in a planning time frame that, if violated, could, under emergency, abnormal, or restorative conditions anticipated by the preparations, directly and adversely affect the electrical state or capability of the bulk electric system, or the ability to effectively monitor, control, or restore the bulk electric system.

However, violation of a medium risk requirement is unlikely, under emergency, abnormal, or restoration conditions anticipated by the preparations, to lead to bulk electric system instability, separation, or cascading failures, nor to hinder restoration to a normal condition.

### ***Lower Risk Requirement***

A requirement that is administrative in nature and a requirement that, if violated, would not be expected to adversely affect the electrical state or capability of the bulk electric system, or the ability to effectively monitor and control the bulk electric system; or, a requirement that is administrative in nature and a requirement in a planning time frame that, if violated, would not, under the emergency, abnormal, or restorative conditions anticipated by the preparations, be expected to adversely affect the electrical state or capability of the bulk electric system, or the ability to effectively monitor, control, or restore the bulk electric system. A planning requirement that is administrative in nature.

### **FERC Violation Risk Factor Guidelines**

The standard drafting team (SDT) also considered consistency with the FERC Violation Risk Factor Guidelines for setting VRFs:<sup>1</sup>

#### **Guideline (1) — Consistency with the Conclusions of the Final Blackout Report**

The Commission seeks to ensure that Violation Risk Factors assigned to Requirements of Reliability Standards in these identified areas appropriately reflect their historical critical impact on the reliability of the Bulk-Power System.

In the VSL Order, FERC listed critical areas (from the Final Blackout Report) where violations could severely affect the reliability of the Bulk-Power System:<sup>2</sup>

- Emergency operations
- Vegetation management
- Operator personnel training
- Protection systems and their coordination
- Operating tools and backup facilities
- Reactive power and voltage control
- System modeling and data exchange
- Communication protocol and facilities
- Requirements to determine equipment ratings
- Synchronized data recorders
- Clearer criteria for operationally critical facilities
- Appropriate use of transmission loading relief

#### **Guideline (2) — Consistency within a Reliability Standard**

<sup>1</sup> North American Electric Reliability Corp., 119 FERC ¶ 61,145, order on reh'g and compliance filing, 120 FERC ¶ 61,145 (2007) ("VRF Rehearing Order").

<sup>2</sup> Id. at footnote 15.

The Commission expects a rational connection between the sub-Requirement Violation Risk Factor assignments and the main Requirement Violation Risk Factor assignment.

**Guideline (3) – Consistency among Reliability Standards**

The Commission expects the assignment of Violation Risk Factors corresponding to Requirements that address similar reliability goals in different Reliability Standards would be treated comparably.

**Guideline (4) – Consistency with NERC’s Definition of the Violation Risk Factor Level**

Guideline (4) was developed to evaluate whether the assignment of a particular Violation Risk Factor level conforms to NERC’s definition of that risk level.

**Guideline (5) – Treatment of Requirements that Co-mingle More Than One Obligation**

Where a single Requirement co-mingles a higher risk reliability objective and a lesser risk reliability objective, the VRF assignment for such Requirements must not be watered down to reflect the lower risk level associated with the less important objective of the Reliability Standard.

**NERC Criteria - Violation Severity Levels**

Violation Severity Levels (VSLs) define the degree to which compliance with a requirement was not achieved. Each requirement must have at least one VSL. While it is preferable to have four VSLs for each requirement, some requirements do not have multiple “degrees” of noncompliant performance and may have only one, two, or three VSLs.

Violation severity levels should be based on the guidelines shown in the table below:

Lower	Moderate	High	Severe
Missing a minor element (or a small percentage) of the required performance The performance or product measured has significant value as it almost meets the full intent of the requirement.	Missing at least one significant element (or a moderate percentage) of the required performance. The performance or product measured still has significant value in meeting the intent of the requirement.	Missing more than one significant element (or is missing a high percentage) of the required performance or is missing a single vital component. The performance or product has limited value in meeting the intent of the requirement.	Missing most or all of the significant elements (or a significant percentage) of the required performance. The performance measured does not meet the intent of the requirement or the product delivered cannot be used in meeting the intent of the requirement.



***FERC Order on Violation Severity Levels***

In its June 19, 2008 Order on Violation Severity Levels, FERC indicated it would use the following four guidelines for determining whether to approve VSLs:

***Guideline 1: Violation Severity Level Assignments Should Not Have the Unintended Consequence of Lowering the Current Level of Compliance***

Compare the VSLs to any prior Levels of Non-compliance and avoid significant changes that may encourage a lower level of compliance than was required when Levels of Non-compliance were used.

***Guideline 2: Violation Severity Level Assignments Should Ensure Uniformity and Consistency in the Determination of Penalties***

Guideline 2a: A violation of a “binary” type requirement must be a “Severe” VSL.

Guideline 2b: Do not use ambiguous terms such as “minor” and “significant” to describe noncompliant performance.

***Guideline 3: Violation Severity Level Assignment Should Be Consistent with the Corresponding Requirement***

VSLs should not expand on what is required in the requirement.

***Guideline 4: Violation Severity Level Assignment Should Be Based on A Single Violation, Not on A Cumulative Number of Violations***

. . . unless otherwise stated in the requirement, each instance of non-compliance with a requirement is a separate violation. Section 4 of the Sanction Guidelines states that assessing penalties on a per violation per day basis is the “default” for penalty calculations.

**VRF and VSL Justifications – PRC-026-1, R1**

<b>Proposed VRF</b>	<b>Medium</b>
NERC VRF Discussion	<p>A Violation Risk Factor of Medium is consistent with the NERC VRF Guidelines:</p> <p>A failure to notify the respective Generator Owner or Transmission Owner of the BES Element(s) that meet the Requirement R1 criteria prohibits further evaluation of any load-responsive protective relay applied at the terminal of the Element(s). A load-responsive protective relay that goes without evaluation may not be secure for a stable power swing and could, in the planning time frame, under emergency, abnormal, or restorative conditions anticipated by the preparations, directly and adversely affect the electrical state or capability of the bulk electric system, or the ability to effectively monitor, control, or restore the bulk electric system.</p>
FERC VRF G1 Discussion	<p>Guideline 1- Consistency w/ Blackout Report:</p> <p>The blackout report and subsequent technical analysis identified that two Bulk Power System (BPS) transmission lines tripped due to protective relay operation in response to stable power swings. The Protection System operations on these lines did not contribute significantly to the overall outcome of the August 14, 2003 system disturbance; however, Protection System operation during stable powers swings could negatively impact system reliability under different operating conditions. Identification and evaluation of BES Elements susceptible to power swings and the subsequent mitigation of load-responsive protective relays applied at the terminals of these BES Elements that do not meet the PRC-026-1 – Attachment B criteria will reduce the likelihood of reoccurrence.</p> <p>This Requirement is consistent with the intent of Recommendation 8: Improve System Protection to Slow or Limit the Spread of Future Cascading Outages. While the actions associated with this recommendation did not focus specifically on the issue of Protection Systems tripping in response to stable power swings, the recommendation does note that “power system protection devices should be set to address the specific condition of concern, such as a fault, out-of-step condition, etc., and should not compromise a power system’s inherent physical capability to slow down or stop a cascading event.”</p>

VRF and VSL Justifications – PRC-026-1, R1	
FERC VRF G2 Discussion	<p>Guideline 2- Consistency within a Reliability Standard:</p> <p>The Requirement has a single reliability activity associated with the reliability objective and no sub-Requirement(s) which allows a single VRF to be assigned; therefore no conflict(s) exist.</p>
FERC VRF G3 Discussion	<p>Guideline 3- Consistency among Reliability Standards:</p> <p>The Requirement is consistent with NERC Reliability Standard FAC-014-2, R6 (“...Planning Authority shall identify the subset of multiple contingencies...”) which has a VRF of Medium.</p>
FERC VRF G4 Discussion	<p>Guideline 4- Consistency with NERC Definitions of VRFs:</p> <p>A failure of the Planning Coordinator to notify the respective Generator Owner or Transmission Owner of the BES Element(s) that meet the Requirement R1 criteria prohibits further evaluation of any load-responsive protective relay applied at the terminal of the Element. A load-responsive protective relay that goes without evaluation may not be secure for a stable power swing and could, in the planning time frame, under emergency, abnormal, or restorative conditions anticipated by the preparations, directly and adversely affect the electrical state or capability of the bulk electric system, or the ability to effectively monitor, control, or restore the bulk electric system.</p>
FERC VRF G5 Discussion	<p>Guideline 5- Treatment of Requirements that Co-mingle More than One Obligation:</p> <p>This Requirement does not co-mingle reliability objectives of differing risk; therefore, the assigned VRF of Medium is consistent.</p>

<b>VRF and VSL Justifications – PRC-026-1, R1</b>			
<b>Proposed VSL</b>			
<b>Lower</b>	<b>Moderate</b>	<b>High</b>	<b>Severe</b>
The Planning Coordinator provided notification of the BES Element(s) in accordance with Requirement R1, but was less than or equal to 30 calendar days late.	The Planning Coordinator provided notification of the BES Element(s) in accordance with Requirement R1, but was more than 30 calendar days and less than or equal to 60 calendar days late.	The Planning Coordinator provided notification of the BES Element(s) in accordance with Requirement R1, but was more than 60 calendar days and less than or equal to 90 calendar days late.	The Planning Coordinator provided notification of the BES Element(s) in accordance with Requirement R1, but was more than 90 calendar days late.  OR The Planning Coordinator failed to provide notification of the BES Element(s) in accordance with Requirement R1.
NERC VSL Guidelines	Meets NERC’s VSL Guidelines—There is an incremental aspect to the VSL for tardiness and a binary aspect for failure. The VSL is entity size-neutral because performance is Element-driven and not by the total assets which an entity may have awareness over.		
FERC VSL G1 Violation Severity Level Assignments Should Not Have the Unintended Consequence of Lowering the Current Level of Compliance	The proposed VSL does not lower the current level of compliance because the Requirement is new.		

VRF and VSL Justifications – PRC-026-1, R1

<p>FERC VSL G2</p> <p>Violation Severity Level Assignments Should Ensure Uniformity and Consistency in the Determination of Penalties</p> <p>Guideline 2a: The Single Violation Severity Level Assignment Category for "Binary" Requirements Is Not Consistent</p> <p>Guideline 2b: Violation Severity Level Assignments that Contain Ambiguous Language</p>	<p>Guideline 2a:</p> <p>This Requirement is binary and utilizes a VSL of Severe for failure in addition to incremental VSLs for tardiness.</p> <p>Guideline 2b:</p> <p>The proposed VSL does not use any ambiguous terminology, thereby supporting uniformity and consistency in the determination of similar penalties for similar violations.</p>
<p>FERC VSL G3</p> <p>Violation Severity Level Assignment Should Be Consistent with the Corresponding Requirement</p>	<p>The proposed VSL uses similar terminology to that used in the corresponding Requirement, and is therefore consistent with the Requirement.</p>
<p>FERC VSL G4</p> <p>Violation Severity Level Assignment Should Be Based on A Single Violation, Not on A Cumulative Number of Violations</p>	<p>The VSL is based on a single violation and not cumulative violations.</p>

VRF and VSL Justifications – PRC-026-1, R2

Proposed VRF	High
NERC VRF Discussion	<p>A Violation Risk Factor of High is consistent with the NERC VRF Guidelines:</p> <p>A failure to evaluate the Protection System to determine that it is expected to not trip for a stable power swing for a BES Element could, under emergency, abnormal, or restorative conditions anticipated by the preparations, directly cause or contribute to bulk electric system instability, separation, or a cascading sequence of failures, or could place the bulk electric system at an unacceptable risk of instability, separation, or cascading failures, or could hinder restoration to a normal condition.</p> <p>A Protection System that does not meet the PRC-026-1 – Attachment B criteria is less secure during stable power swings, which increases the risk of tripping should the Protection System be challenged by a power swing.</p>
FERC VRF G1 Discussion	<p>Guideline 1- Consistency w/ Blackout Report:</p> <p>The blackout report and subsequent technical analysis identified that two bulk power system (BPS) transmission lines tripped due to protective relay operation in response to stable power swings. The Protection System operations on these lines did not contribute significantly to the overall outcome of the August 14, 2003 system disturbance; however, Protection System operation during stable powers swings could negatively impact system reliability under different operating conditions. Evaluation of load-responsive protective relays applied at the terminals of identified BES Elements will allow the Generator Owner and Transmission Owner to determine whether the load-responsive protective relays meet the PRC-026-1 – Attachment B criteria.</p> <p>This Requirement is consistent with the intent of Recommendation 8: Improve System Protection to Slow or Limit the Spread of Future Cascading Outages. While the actions associated with this recommendation did not focus specifically on this issue of Protection Systems tripping in response to stable power swings, the recommendation does note that “power system protection devices should be set to address the specific condition of concern, such as a fault, out-of-step condition, etc., and should not compromise a power system’s inherent physical capability to slow down or stop a cascading event.”</p>

VRF and VSL Justifications – PRC-026-1, R2	
FERC VRF G2 Discussion	<p>Guideline 2- Consistency within a Reliability Standard:</p> <p>The Requirement has a single reliability activity associated with the reliability objective and no sub-Requirement(s) which allows a single VRF to be assigned; therefore no conflict(s) exist.</p>
FERC VRF G3 Discussion	<p>Guideline 3- Consistency among Reliability Standards:</p> <p>The Requirement is consistent with NERC Reliability Standard PRC-023-3, R1 (“...Each Transmission Owner, Generator Owner, and Distribution Provider shall evaluate relay loadability at 0.85 per unit voltage and a power factor angle of 30 degrees”) which has a VRF of High.</p>
FERC VRF G4 Discussion	<p>Guideline 4- Consistency with NERC Definitions of VRFs:</p> <p>A failure of the Generator Owner or Transmission Owner to evaluate that the Protection System is expected to not trip in response to a stable power swing during a non-Fault condition for a BES Element could, under emergency, abnormal, or restorative conditions anticipated by the preparations, directly cause or contribute to bulk electric system instability, separation, or a cascading sequence of failures, or could place the bulk electric system at an unacceptable risk of instability, separation, or cascading failures, or could hinder restoration to a normal condition.</p> <p>A Protection System that does not meet the PRC-026-1 – Attachment B criteria is less secure during stable power swings, it increases the risk of tripping should the Protection System be challenged by a power swing.</p>
FERC VRF G5 Discussion	<p>Guideline 5- Treatment of Requirements that Co-mingle More than One Obligation:</p> <p>This Requirement does not co-mingle reliability objectives of differing risk; therefore, the assigned VRF of Medium is consistent.</p>

VRF and VSL Justifications – PRC-026-1, R2			
Proposed VSL			
Lower	Moderate	High	Severe
The Generator Owner or Transmission Owner evaluated its load-responsive protective relay(s) in accordance with Requirement R2, but was less than or equal to 30 calendar days late.	The Generator Owner or Transmission Owner evaluated its load-responsive protective relay(s) in accordance with Requirement R2, but was more than 30 calendar days and less than or equal to 60 calendar days late.	The Generator Owner or Transmission Owner evaluated its load-responsive protective relay(s) in accordance with Requirement R2, but was more than 60 calendar days and less than or equal to 90 calendar days late.	The Generator Owner or Transmission Owner evaluated its load-responsive protective relay(s) in accordance with Requirement R2, but was more than 90 calendar days late.  OR The Generator Owner or Transmission Owner failed to evaluate its load-responsive protective relay(s) in accordance with Requirement R2.
NERC VSL Guidelines	Meets NERC’s VSL Guidelines—There is an incremental aspect to the VSL for tardiness and a binary aspect for failure. The VSL is entity size-neutral because performance is driven by exception. For example, each identified Element must be evaluated.		
FERC VSL G1 Violation Severity Level Assignments Should Not Have the Unintended Consequence of Lowering the Current Level of Compliance	The proposed VSL does not lower the current level of compliance because the Requirement is new.		



VRF and VSL Justifications – PRC-026-1, R2

<p>FERC VSL G2</p> <p>Violation Severity Level Assignments Should Ensure Uniformity and Consistency in the Determination of Penalties</p> <p>Guideline 2a: The Single Violation Severity Level Assignment Category for "Binary" Requirements Is Not Consistent</p> <p>Guideline 2b: Violation Severity Level Assignments that Contain Ambiguous Language</p>	<p>Guideline 2a:</p> <p>This Requirement is not binary; therefore, this criterion does not apply.</p> <p>Guideline 2b:</p> <p>The proposed VSL does not use any ambiguous terminology, thereby supporting uniformity and consistency in the determination of similar penalties for similar violations.</p>
<p>FERC VSL G3</p> <p>Violation Severity Level Assignment Should Be Consistent with the Corresponding Requirement</p>	<p>The proposed VSL uses similar terminology to that used in the corresponding Requirement, and is therefore consistent with the Requirement.</p>
<p>FERC VSL G4</p> <p>Violation Severity Level Assignment Should Be Based on A Single Violation, Not on A Cumulative Number of Violations</p>	<p>The VSL is based on a single violation and not cumulative violations.</p>

VRF and VSL Justifications – PRC-004-3, R3

Proposed VRF	Medium
NERC VRF Discussion	<p>A Violation Risk Factor of Medium is consistent with the NERC VRF Guidelines:</p> <p>Failure to develop a Corrective Action Plan (CAP) such that the Protection System of a BES Element will meet the PRC-026-1 – Attachment B criteria or to exclude the Protection System under the PRC-026-1 – Attachment A criteria (e.g., modifying the Protection System so that relay functions are supervised by power swing blocking or using relay systems that are immune to power swings) could in the planning time frame, under emergency, abnormal, or restorative conditions anticipated by the preparations, directly and adversely affect the electrical state or capability of the bulk electric system, or the ability to effectively monitor, control, or restore the bulk electric system.</p>
FERC VRF G1 Discussion	<p>Guideline 1- Consistency w/ Blackout Report:</p> <p>The blackout report and subsequent technical analysis identified that two bulk power system (BPS) transmission lines tripped due to protective relay operation in response to stable power swings. The Protection System operations on these lines did not contribute significantly to the overall outcome of the August 14, 2003 system disturbance; however, Protection System operation during stable powers swings could negatively impact system reliability under different operating conditions. Developing a CAP such that the Protection System will meet the Attachment B criteria or to exclude the Protection System under the PRC-026-1 – Attachment A criteria (e.g., modifying the Protection System so that relay functions are supervised by power swing blocking or using relay systems that are immune to power swings) applied at the terminals of BES Elements will reduce the likelihood of reoccurrence.</p> <p>This Requirement is consistent with the intent of Recommendation 8: Improve System Protection to Slow or Limit the Spread of Future Cascading Outages. While the actions associated with this recommendation did not focus specifically on this issue of Protection Systems tripping in response to stable power swings, the recommendation does note that “power system protection devices should be set to address the specific condition of concern, such as a fault, out-of-step condition, etc., and should not compromise a power system’s inherent physical capability to slow down or stop a cascading event.”</p>

VRF and VSL Justifications – PRC-004-3, R3	
FERC VRF G2 Discussion	<p>Guideline 2- Consistency within a Reliability Standard:</p> <p>This Requirement has a single reliability activity associated with the reliability objective and no sub-Requirement(s) which allows a single VRF to be assigned; therefore no conflict(s) exist.</p>
FERC VRF G3 Discussion	<p>Guideline 3- Consistency among Reliability Standards:</p> <p>This Requirement is consistent with the following Reliability Standards which require corrective actions (e.g., Corrective Action Plans); PRC-016-0.1, R2 (“...shall take corrective actions to avoid future Misoperations”), PRC-022-1, R1.5 (“For any Misoperation, a Corrective Action Plan...”), and FAC-003, R5 (“...Transmission Owner or applicable Generator Owner shall take corrective action to ensure continued vegetation management”) all three of which have a VRF of Medium.</p>
FERC VRF G4 Discussion	<p>Guideline 4- Consistency with NERC Definitions of VRFs:</p> <p>A Violation Risk Factor of Medium is consistent with the NERC VRF Guidelines:</p> <p>A failure to develop the Corrective Action Plan (CAP) such that the Protection System of a BES Element will meet the Attachment B criteria or to exclude the Protection System under the PRC-026-1 – Attachment A criteria (e.g., modifying the Protection System so that relay functions are supervised by power swing blocking or using relay systems that are immune to power swings) could, in the planning time frame, under emergency, abnormal, or restorative conditions anticipated by the preparations, directly and adversely affect the electrical state or capability of the bulk electric system, or the ability to effectively monitor, control, or restore the bulk electric system.</p>
FERC VRF G5 Discussion	<p>Guideline 5- Treatment of Requirements that Co-mingle More than One Obligation:</p> <p>This requirement does not co-mingle reliability objectives of differing risk; therefore, the assigned VRF of Medium is consistent.</p>

VRF and VSL Justifications – PRC-004-3, R3			
Proposed VSL			
Lower	Moderate	High	Severe
The Generator Owner or Transmission Owner developed a Corrective Action Plan (CAP) in accordance with Requirement R3, but in more than six calendar months and less than or equal to seven calendar months.	The Generator Owner or Transmission Owner developed a Corrective Action Plan (CAP) in accordance with Requirement R3, but in more than seven calendar months and less than or equal to eight calendar months.	The Generator Owner or Transmission Owner developed a Corrective Action Plan (CAP) in accordance with Requirement R3, but in more than eight calendar months and less than or equal to nine calendar months.	The Generator Owner or Transmission Owner developed a Corrective Action Plan (CAP) in accordance with Requirement R3, but in more than nine calendar months.  OR The Generator Owner or Transmission Owner failed to develop a CAP in accordance with Requirement R3.
NERC VSL Guidelines	Meets NERC’s VSL Guidelines—There is an incremental aspect to the VSL for failing to develop the Corrective Action Plan in a timely fashion and a binary aspect for a complete failure. The VSL is entity size-neutral because performance is driven by the need to mitigate the Protection System so that it is expected to not trip on a stable power swing.		
FERC VSL G1 Violation Severity Level Assignments Should Not Have the Unintended Consequence of Lowering the Current Level of Compliance	The proposed VSL does not lower the current level of compliance because the Requirement is new.		

VRF and VSL Justifications – PRC-004-3, R3

<p>FERC VSL G2</p> <p>Violation Severity Level Assignments Should Ensure Uniformity and Consistency in the Determination of Penalties</p> <p>Guideline 2a: The Single Violation Severity Level Assignment Category for "Binary" Requirements Is Not Consistent</p> <p>Guideline 2b: Violation Severity Level Assignments that Contain Ambiguous Language</p>	<p>Guideline 2a:</p> <p>This Requirement is binary and utilizes a VSL of Severe for failure in addition to incremental VSLs for tardiness.</p> <p>Guideline 2b:</p> <p>This proposed VSL does not use any ambiguous terminology, thereby supporting uniformity and consistency in the determination of similar penalties for similar violations.</p>
<p>FERC VSL G3</p> <p>Violation Severity Level Assignment Should Be Consistent with the Corresponding Requirement</p>	<p>This proposed VSL uses similar terminology to that used in the corresponding Requirement, and is therefore consistent with this Requirement.</p>
<p>FERC VSL G4</p> <p>Violation Severity Level Assignment Should Be Based on A Single Violation, Not on A Cumulative Number of Violations</p>	<p>The VSL is based on a single violation and not cumulative violations.</p>

VRF and VSL Justifications – PRC-026-1, R4	
Proposed VRF	Medium
NERC VRF Discussion	<p>A Violation Risk Factor of Medium is consistent with the NERC VRF Guidelines:</p> <p>A failure to implement the Corrective Action Plan (CAP) to meet the PRC-026-1 – Attachment B criteria or to exclude the Protection System under the PRC-026-1 – Attachment A criteria (e.g., modifying the Protection System so that relay functions are supervised by power swing blocking or using relay systems that are immune to power swings) could, in the planning time frame, under emergency, abnormal, or restorative conditions anticipated by the preparations, directly and adversely affect the electrical state or capability of the bulk electric system, or the ability to effectively monitor, control, or restore the bulk electric system.</p>
FERC VRF G1 Discussion	<p>Guideline 1- Consistency w/ Blackout Report:</p> <p>The blackout report and subsequent technical analysis identified that two bulk power system (BPS) transmission lines tripped due to protective relay operation in response to stable power swings. The Protection System operations on these lines did not contribute significantly to the overall outcome of the August 14, 2003 system disturbance; however, Protection System operation during stable powers swings could negatively impact system reliability under different operating conditions. Implementing a CAP such that the Protection System will meet the Attachment B criteria or to exclude the Protection System under the PRC-026-1 – Attachment A criteria (e.g., modifying the Protection System so that relay functions are supervised by power swing blocking or using relay systems that are immune to power swings) applied at the terminals of these Elements will reduce the likelihood of reoccurrence.</p> <p>This Requirement is consistent with the intent of Recommendation 8: Improve System Protection to Slow or Limit the Spread of Future Cascading Outages. While the actions associated with this recommendation did not focus specifically on this issue of Protection Systems tripping in response to stable power swings, the recommendation does note that “power system protection devices should be set to address the</p>

VRF and VSL Justifications – PRC-026-1, R4	
	specific condition of concern, such as a fault, out-of-step condition, etc., and should not compromise a power system’s inherent physical capability to slow down or stop a cascading event.”
FERC VRF G2 Discussion	<p>Guideline 2- Consistency within a Reliability Standard:</p> <p>The Requirement has a single reliability activity associated with the reliability objective and no sub-Requirement(s) which allows a single VRF to be assigned; therefore no conflict(s) exist.</p>
FERC VRF G3 Discussion	<p>Guideline 3- Consistency among Reliability Standards:</p> <p>This Requirement is consistent with the following Reliability Standards which require corrective actions (e.g., Corrective Action Plans): PRC-016-0.1, R2 (“...shall take corrective actions to avoid future Misoperations”), PRC-022-1, R1.5 (“For any Misoperation, a Corrective Action Plan...”), and FAC-003, R5 (“...Transmission Owner or applicable Generator Owner shall take corrective action to ensure continued vegetation management”) all of which have a VRF of Medium.</p>
FERC VRF G4 Discussion	<p>A Violation Risk Factor of Medium is consistent with the NERC VRF Guidelines:</p> <p>A failure to implement the Corrective Action Plan such that the Protection System of a BES Element will meet the Attachment B criteria or to exclude the Protection System under the PRC-026-1 – Attachment A criteria (e.g., modifying the Protection System so that relay functions are supervised by power swing blocking or using relay systems that are immune to power swings) could, in the planning time frame, under emergency, abnormal, or restorative conditions anticipated by the preparations, directly and adversely affect the electrical state or capability of the bulk electric system, or the ability to effectively monitor, control, or restore the bulk electric system.</p>
FERC VRF G5 Discussion	<p>Guideline 5- Treatment of Requirements that Co-mingle More than One Obligation:</p> <p>This Requirement does not co-mingle reliability objectives of differing risk; therefore, the assigned VRF of Medium is consistent.</p>

VRF and VSL Justifications – PRC-026-1, R4			
Proposed VSL			
Lower	Moderate	High	Severe
The responsible entity implemented, but failed to update a CAP, when actions or timetables changed, in accordance with Requirement R4.	N/A	N/A	The responsible entity failed to implement a CAP in accordance with Requirement R4.
NERC VSL Guidelines			
Meets NERC’s VSL Guidelines—There is an incremental aspect to the VSL for failing to update the Corrective Action Plan and a binary aspect for failure to implement. The VSL is entity size-neutral because performance is driven by the need to mitigate the Protection System so that it is expected to not trip on a stable power swing.			
FERC VSL G1 Violation Severity Level Assignments Should Not Have the Unintended Consequence of Lowering the Current Level of Compliance			
The proposed VSL does not lower the current level of compliance because the Requirement is new.			
FERC VSL G2 Violation Severity Level Assignments Should Ensure Uniformity and Consistency in the Determination of Penalties			
Guideline 2a: This Requirement is not binary; therefore, this criterion does not apply.			



VRF and VSL Justifications – PRC-026-1, R4

<p>Guideline 2a: The Single Violation Severity Level Assignment Category for "Binary" Requirements Is Not Consistent</p> <p>Guideline 2b: Violation Severity Level Assignments that Contain Ambiguous Language</p>	<p>Guideline 2b:</p> <p>The proposed VSL does not use any ambiguous terminology, thereby supporting uniformity and consistency in the determination of similar penalties for similar violations.</p>
<p>FERC VSL G3</p> <p>Violation Severity Level Assignment Should Be Consistent with the Corresponding Requirement</p>	<p>The proposed VSL uses similar terminology to that used in the corresponding Requirement, and is therefore consistent with the Requirement.</p>
<p>FERC VSL G4</p> <p>Violation Severity Level Assignment Should Be Based on A Single Violation, Not on A Cumulative Number of Violations</p>	<p>The VSL is based on a single violation and not cumulative violations.</p>

**Exhibit G**

**Summary of Development History and Complete Record of Development**

## **Exhibit G: Summary of Development History**

The development record for proposed Reliability Standard PRC-026-1 is summarized below. The proposed Reliability Standard was developed in an open and fair manner and in accordance with the Commission-approved Reliability Standard development process.<sup>1</sup> NERC develops Reliability Standards in accordance with Section 300 (Reliability Standards Development) of its Rules of Procedure and the NERC Standard Processes Manual.<sup>2</sup> In its order certifying NERC as the Commission's Electric Reliability Organization, the Commission found that NERC's proposed rules provide for reasonable notice and opportunity for public comment, due process, openness, and a balance of interests in developing Reliability Standards<sup>3</sup> and thus satisfies certain of the criteria for approving Reliability Standards.<sup>4</sup> The development process is open to any person or entity with a legitimate interest in the reliability of the Bulk-Power System. NERC considers the comments of all stakeholders, and stakeholders must approve, and the NERC Board of Trustees must adopt a Reliability Standard before the Reliability Standard is submitted to the Commission for approval.

---

<sup>1</sup> *Rules Concerning Certification of the Electric Reliability Organization; and Procedures for the Establishment, Approval, and Enforcement of Electric Reliability Standards*, Order No. 672 at P 334, FERC Stats. & Regs. ¶ 31,204, *order on reh'g*, Order No. 672-A, FERC Stats. & Regs. ¶ 31,212 (2006) ("Further, in considering whether a proposed Reliability Standard meets the legal standard of review, we will entertain comments about whether the ERO implemented its Commission-approved Reliability Standard development process for the development of the particular proposed Reliability Standard in a proper manner, especially whether the process was open and fair. However, we caution that we will not be sympathetic to arguments by interested parties that choose, for whatever reason, not to participate in the ERO's Reliability Standard development process if it is conducted in good faith in accordance with the procedures approved by FERC.").

<sup>2</sup> The NERC *Rules of Procedure* are available at <http://www.nerc.com/AboutNERC/Pages/Rules-of-Procedure.aspx>. The NERC *Standard Processes Manual* is available at [http://www.nerc.com/comm/SC/Documents/Appendix\\_3A\\_StandardsProcessesManual.pdf](http://www.nerc.com/comm/SC/Documents/Appendix_3A_StandardsProcessesManual.pdf).

<sup>3</sup> 116 FERC ¶ 61,062 at P 250.

<sup>4</sup> Order No. 672 at PP 268, 270.

## **I. Overview of the Standard Drafting Team**

When evaluating a proposed Reliability Standard, the Commission is expected to give “due weight” to the technical expertise of the ERO<sup>5</sup>. The technical expertise of the ERO is derived from the standard drafting team. For this project, the standard drafting team consisted of industry experts, all with a diverse set of experiences. A roster of the standard drafting team members is included in Exhibit H.

## **II. Standard Development History**

### **A. Standard Authorization Request**

The Standard Authorization Request (“SAR”) was posted for a formal comment period from August 19, 2010 through September 19, 2010. The Standards Committee approved the SAR on August 12, 2010.

### **B. First Posting- Comment Period, Ballot and Non-Binding Poll**

Proposed Reliability Standard PRC-026-1 was posted for a 45-day public comment period April 25, 2014 through June 9, 2014, with an initial ballot held from May 30, 2014 through June 9, 2014. The initial ballot received a 79.06% quorum, and an approval of 17.02%. The Non-Binding Poll achieved a 77.71% quorum and 17.88% of supportive opinions. There were 70 sets of responses, including comments from approximately 181 individuals from approximately 117 companies, representing all 10 industry segments.

The standard drafting team considered stakeholder comments regarding proposed Reliability Standard PRC-026-1 and made the following observations and modifications based on those comments:

- The standard’s purpose was revised from ensuring “relays do not trip” to “relays are expected to not trip” ... in response to stable power swings during non-Fault conditions.

---

<sup>5</sup> Section 215(d)(2) of the Federal Power Act; 16 U.S.C. §824(d) (2) (2012).

- The Reliability Coordinator and Transmission Planner were removed from the standard to address concerns about overlap and potential gaps when identifying Elements.
- Applicability for the Generator Owner and Transmission Owner was augmented to refer to an appended “Attachment A” which describes load-responsive protective relays that are included in the standard and associated exclusions.
- Requirement R1 was revised substantively to remove the Reliability Coordinator and Transmission Planner functions.
- Added “angular” to clarify that this is not referring to other constraints such as voltage. Also replaced “Special Protection System (SPS)” with “Remedial Action Scheme (RAS)” to comport with expected changes to these NERC defined terms.
- Clarified that criterion 2 applies only to “monitored” Elements of a System Operating Limit (SOL). Also, added “angular” to clarify that this is not referring to other constraints such as voltage.
- Revised the “islanding” criterion to remove ambiguity about islands that formed during planning assessments. Also, added “angular” to clarify that this is not referring to other constraints such as voltage.
- Replaced the term “Disturbance” with the phrase “simulated disturbance,” because it generally refers to an actual and not simulated event. The lowercase term “disturbance” was considered to be consistent with the NERC TPL-001-4 Reliability Standard, but it was determined that its usage would continue to create questions so “simulated” was added. The phrase “stable or unstable” was inserted to clarify that both are applicable to power swings because the goal of the standard is to identify Elements susceptible to either.
- This criterion was added as a mechanism to require the Planning Coordinator to continue identifying any Element that has been reported by a Generator Owner due to a stable or unstable power swing during an actual system Disturbance or by the Transmission Owner due to a stable or unstable power swing during an actual system Disturbance or islanding event.
- Requirement R2 was revised to remove the Generator Owner performance because the Generator Owner does not “island.”
- Requirement R3 is a new requirement created from the previous Requirement R2 specifically for the Generator Owner.
- Requirement R4 (previously R3) has been substantially rewritten to eliminate multiple and varying activities such as, demonstrate, develop, and obtain agreement.
- Requirement R5 was added to address the requirement for developing a Corrective Action Plan (CAP) that was contained in the previous Draft 1, Requirement R3.
- Requirement R6 was previously R4 and only received comports updates due to numbering changes.
- The PRC-026-1 – Attachment A was added to the standard due to reduce stakeholder confusion about what load-responsive protective relays are in scope and to provide specific exclusions.
- The PRC-026-1 – Attachment B was added to the standard to remove the “Criteria” for evaluating load-responsive protective relays from within the

Requirement itself and provide it in an attachment for referencing by Requirement R4.

- The PRC-026-1 – Attachment B now includes an additional Criteria B which provides criteria for overcurrent-based protective relays.

### **C. Second Posting**

Proposed Reliability Standard PRC-026-1 was posted for a 45-day comment period from August 22, 2014 through October 6, 2014, with an additional ballot from September 26, 2014 through October 6, 2014. The additional ballot achieved a 79.01% quorum, and an approval of 53.02%. The Non-Binding Poll achieved a 77.71% quorum and 51.71% of supportive opinions. There were 53 sets of responses, including comments from approximately 147 individuals from approximately 102 companies, representing all 10 industry segments.

The standard drafting team considered stakeholder comments regarding proposed Reliability Standard PRC-026-1 and made the following observations and modifications based on those comments:

- Section 4.2, Facilities was revised from “The following Bulk Electric System Elements” to “The following Elements that are part of the Bulk Electric System (BES)” to clarify that the listed items are the items being addressed in the Requirements as the “Elements.”
- The Elements from the Applicability 4.2 (i.e., generator, transformer, and transmission line BES Elements) was added for clarity.
- Requirement R1 was modified to specifically require “notification” rather than “identify and provide notification.”
- The term “operating limit” was clarified to be “System Operating Limit (SOL)” to remove ambiguity between the operating and planning time frame.
- “Transmission switching station” was revised to be “Transmission station.”
- In Requirement R1, Criterion 2, the phrase “constraints identified in system planning or operating studies” was modified to be “...a SOL identified by the Planning Coordinator’s methodology.”
- Requirement R1, Criterion 3 was rewritten to reflect it is the Element which tripped on angular stability thus forming the island.

- Requirement R1, Criterion 3 was updated to reflect the most recent “design assessment” by the Planning Coordinator (i.e., PRC-006) and when the Planning Coordinator uses angular stability as a design criteria for identifying islands.
- In Requirement R1, Criterion 4, the term “annual” was added to provide clarity.
- In Requirement R1, Criterion 5 was removed from Requirement R1 because Requirements R2 and R3 in Draft 2 were eliminated.
- Measure M1 was updated to reflect changes to Requirement R1 and to clarify that the focus is on notification and not identification of Elements.
- Requirements R2 and R3 were removed due to structural changes in Requirement R4 (now Requirement R2).
- The evaluation Requirement (now R2) was restructured to have two conditions for performance; 1) upon notification of an Element pursuant to Requirement R1, and 2) an actual event due to a stable or unstable power swing.
- Requirements R4 became Requirement R2 due to the removal of Requirements R2 and R3. Most significantly, the Requirement was restructured to incorporate the removal of Requirements R2 and R3.
- Requirements R5 and R6 became Requirements R3 and R4 due to the removal of Requirements R2 and R3.
- The development period of the CAP was extended from 90 calendar days to six calendar months due to the complexities that might be involved with determining appropriate remediation of a Protection System that did not meet PRC-026-1 – Attachment B criteria.
- Section C1.1.2 was modified to conform evidence retention to the Reliability Assurance Initiative (RAI).
- Retention periods were set to 12 calendar months.
- The Violation Severity Levels (VSLs) were modified to align them with the revisions made to the Requirements.
- Attachment A received editorial changes and Attachment B, Criteria A was rewritten to clarify that a relay characteristic that is completely contained within the unstable power swing region meets the criteria.
- The Guidelines and Technical Basis section was revised substantively in response to comments and due to the removal of Requirements R2 and R3.

#### **D. Third Posting**

Proposed Reliability Standard PRC-026-1 was posted for a 21-day comment period from November 4, 2014 through November 24, 2014, with an additional ballot from November 14, 2014 through November 24, 2014. The additional ballot achieved a 79.83% quorum, and an approval of 67.39%. The Non-Binding Poll achieved a 78.61% quorum and 66.13% of supportive opinions. There were 42 sets of responses, including comments from approximately 142 individuals from approximately 88 companies,

representing all 10 industry segments. On December 9, 2014, the Standards Committee approved a waiver request to shorten the next additional formal comment period (and any subsequent additional formal comment periods) for proposed PRC-026-1 from forty-five days to twenty-one days.<sup>6</sup>

The standard drafting team considered stakeholder comments regarding proposed Reliability Standard PRC-026-1 and made the following observations and modifications based on those comments:

- The Background section was updated for clarity.
- In Requirement R1 a footnote was added to draw attention to new detail provided in the Guidelines and Technical Basis concerning the inclusion of “unstable” in Criterion 4.
- Requirement R2, the word “determine” was removed from the main requirement body based on comments as it is duplicative of Parts 2.1 and 2.2.
- In Requirement R2 a footnote was added to draw attention to examples provided in the Guidelines and Technical Basis of how an entity would “become aware” of a stable or unstable power swing.
- In Requirement R2 a footnote was added to draw attention to new detail provided in the Guidelines and Technical Basis concerning the inclusion of “unstable” in Part 2.2.
- In Requirement R2, the rationale box text was updated for clarity.
- In Requirement R3, the phrase “pursuant to Requirement R2” was inserted based on comments to provide a referential link to the previous requirement which triggers performance under Requirement R3.
- In Requirement R3, the clause “or more” was deleted based on comments to remove confusion about whether either or both of the Corrective Action Plan options were required. Although an entity may perform both under certain circumstances, the standard drafting team concluded that performing one of the two bulleted items would achieve the reliability goal of the standard.
- In Requirement R3 the rationale box text was updated for clarity.
- In PRC-026-1 – Attachment A the phrase “provided the distance element is set in accordance with the criteria outlined in the standard” has been removed from a bullet in the PRC-026-1 – Attachment A (protection system functions that are excluded from the standard) pertaining to phase fault detector relay elements that supervise other load-responsive phase distance elements.

---

<sup>6</sup> See Standards Committee Dec. 9, 2014 Meeting Agenda at 2, available at [http://www.nerc.com/comm/SC/Agenda%20Highlights%20and%20Minutes/sc\\_agenda\\_package\\_120914\\_final2\\_120314.pdf](http://www.nerc.com/comm/SC/Agenda%20Highlights%20and%20Minutes/sc_agenda_package_120914_final2_120314.pdf).



- In PRC-026-1 – Attachment B the uses of “Criteria” were replaced by “Criterion” for correctness.
- In PRC-026-1 – Attachment B the order of “sending-end” to “receiving-end” voltages were reversed and swapped for correctness.
- In the Guidelines and Technical Basis several Figures were corrected due to errors reported through the comments.
- Several calculations in the Tables were corrected, Table 13 in particular.
- Several revisions were due to inconsistencies within the document on how information is presented.
- The format of the Guidelines and Technical Basis was updated for consistency with the NERC style guide.
- The section, “Justification for Including Unstable Power Swings in the Requirements” was appended to provide an understanding of why “unstable” power swings are relevant to the performance of the Standard.
- In the Implementation Plan, “Notifications Prior to the Effective Date of Requirement R2” was made to clarify an entity’s obligations during the implementation plan period.
- In the VRF and VSL Justifications section several paragraphs that were redundant with other information were removed.

#### **E. Final Ballot**

Proposed Reliability Standard PRC-026-1 was posted for a 10-day public comment period from December 5, 2014 through December 16, 2014.<sup>7</sup> The proposed Reliability Standard received a quorum of 84.81% and an approval of 68.08%.

#### **F. Board of Trustees Adoption**

Proposed Reliability Standard PRC-026-1 was adopted by the NERC Board of Trustees on December 17, 2014.

---

<sup>7</sup> The final ballot close date was extended one day to December 16, 2014 due to a NERC.com maintenance outage that occurred Saturday, December 13, 2014.

## **Program Areas & Departments > Standards > Project 2010-13.3 Phase 3 of Relay Loadability: Stable Power Swings**

Project 2010-13.3 Phase 3 of Relay Loadability: Stable Power Swings

Rich HTML Content 1

[Related Files](#)

### **Status:**

A final ballot for **PRC-026-1 – Relay Performance During Stable Power Swings** concluded at **8 p.m. Eastern on Tuesday, December 16, 2014**.

Voting results can be accessed via the link below. The standard will be submitted to the Board of Trustees for adoption and then filed with the appropriate regulatory authorities.

### **Background:**

The March 18, 2010, FERC Order No. 733, approved Reliability Standard PRC-023-1 – Transmission Relay Loadability. In this Order, FERC directed NERC to address three areas of relay loadability that include modifications to the approved PRC-023-1, developing a new Reliability Standard to address generator protective relay loadability, and another Reliability Standard to address the operation of protective relays due to stable power swings. This project's SAR addresses these directives and establishes a three-phased approach to standard development.

This Phase 3 of the project is focused on developing a new Reliability Standard, PRC-026-1 – Stable Power Swing Relay Loadability, to address protective relay operations due to stable power swings. This Reliability Standard will establish requirements aimed at preventing protective relays from operating unnecessarily due to stable power swings by requiring the use of protective relay systems that can differentiate between faults and stable power swings and, when necessary, phases-out relays that cannot meet this requirement.

Phase 2 was focused on developing a new Reliability Standard, PRC-025-1 – Generator Relay Loadability, to address generator protective relay loadability which is currently awaiting regulatory approval.

Phase 1 was focused on making the specific modifications to PRC-023-1 and was completed in the approved Reliability Standard PRC-023-2, which became mandatory on July 1, 2012.

### **Purpose/Industry Need:**

The Commission observed that PRC-023-1 does not address stable power swings, and pointed out that currently available protection applications and relays, such as pilot wire differential, phase comparison and blinder-blocking applications and relays, and impedance relays with non-circular operating characteristics, are demonstrably less susceptible to operating unnecessarily because of stable power swings. Given the availability of alternatives, the Commission stated that the use of protective relay systems that cannot

differentiate between faults and stable power swings constitutes miscoordination of the protection system and is inconsistent with entities' obligations under existing Reliability Standards.

In this Final Rule the Commission decided not to direct the ERO to modify PRC-023-1 to address stable power swings. However, because both NERC and the U.S.-Canada Power System Outage Task Force have identified undesirable relay operation due to stable power swings as a reliability issue, the Commission directed the ERO to develop a Reliability Standard that requires use of protective relay systems that can differentiate between faults and stable power swings and, when necessary, phases out protective relays that cannot meet this requirement.

Draft	Action	Dates	Results	Consideration of Comments
<p><b>Final Draft</b>            PRC-026-1            Clean (53)              Redline to Last            Posted (54)            Implementation            Plan            Clean (55)              Redline to Last            Posted (56)  <b>Supporting            Documents:</b>            VRF and VSL            Justification            Clean (57)              Redline to Last            Posted (58)              Responses to            Directives and            Issues (59)</p>	<p>Final Ballot            Info&gt;&gt; (60)            Vote&gt;&gt;</p>	<p>12/05/14            –            12/16/14            (closed)</p>	<p>Summary&gt;&gt;            (61)              Ballot            Results&gt;&gt;            (62)</p>	
<p><b>Draft 3</b>            PRC-026-1            Clean (37)              Redline (38)</p>	<p>Additional Ballot and            Non-binding Poll              Updated Info&gt;&gt; (45)</p>	<p>11/14/14            -            11/24/14            (closed)</p>	<p>Summary&gt;&gt;            (48)              Ballot            Results&gt;&gt;            (49)</p>	<p>Consideration            of            Comments&gt;&gt;            (52)</p>

<p>Implementation Plan Clean (39)   Redline (40)</p> <p><b>Supporting Documents:</b></p> <p>Unofficial Comment Form (Word) (41)</p> <p>VRF and VSL Justification Clean (42)   Redline (43)</p> <p>Response to Directives and Issues (44)</p> <p>Lens Characteristic Tool <b>(Link to projects page)</b></p> <p>Lens Characteristic Tool (Generator) <b>(Link to projects page)</b></p> <p>Draft RSAW</p>	<p><a href="#">Info&gt;&gt; (46)</a></p> <p><a href="#">Vote&gt;&gt;</a></p>		<p><a href="#">Non-Binding Poll Results&gt;&gt; (50)</a></p>	
	<p>Comment Period</p> <p><a href="#">Info&gt;&gt; (47)</a></p> <p><a href="#">Submit Comments&gt;&gt;</a></p>	<p>11/04/14 - 11/24/14 (closed)</p>	<p><a href="#">Comments Received&gt;&gt; (51)</a></p>	
	<p>Please send RSAW Feedback to: <a href="mailto:RSAWfeedback@nerc.net">RSAWfeedback@nerc.net</a></p>	<p>11/12/14 - 12/02/14</p>		
<p>Notice of Request to Waive the Standard Process (36)</p>				

<p><b>Draft 2</b></p> <p>PRC-026-1 Clean (20)   Redline (21)</p> <p>Implementation Plan Clean (22)   Redline (23)</p>	<p>Additional Ballot and Non-binding Poll</p> <p>Updated Info&gt;&gt; (28)</p> <p>Info&gt;&gt; (29)</p> <p>Vote&gt;&gt;</p>	<p>09/26/14 - 10/06/14 (closed)</p>	<p>Summary&gt;&gt; (31)</p> <p>Ballot Results&gt;&gt; (32)</p> <p>Non-Binding Poll Results&gt;&gt; (33)</p>	
<p><b>Supporting Documents:</b></p> <p>Unofficial Comment Form (Word) (24)</p>	<p>Comment Period</p> <p>Info&gt;&gt; (30)</p> <p>Submit Comments&gt;&gt;</p>	<p>08/22/14 - 10/06/14 (closed)</p>		
<p>VRF and VSL Justification Clean (25)   Redline (26)</p> <p>Response to Directives and Issues (27)</p> <p><u><a href="#">Lens Characteristic Tool</a></u>  <u><a href="#">(Link to projects page)</a></u></p> <p><u><a href="#">Lens Characteristic Tool (Generator)</a></u>  <u><a href="#">(Link to projects page)</a></u></p>	<p>Please send RSAW Feedback to: <a href="mailto:RSAWfeedback@nerc.net">RSAWfeedback@nerc.net</a></p>	<p>09/11/14 - 10/06/14</p>	<p>Comments Received&gt;&gt; (34)</p>	<p>Consideration of Comments&gt;&gt; (35)</p>

<p>(The above are MS Excel macro-enabled spreadsheets)</p> <p>Draft RSAW</p>				
<p><b>Draft 1</b> PRC-026-1 (6)</p> <p>Implementation Plan (7)</p> <p><b>Supporting Documents:</b> Unofficial Comment Form (Word) (8)</p> <p>VRF and VSL Justifications (9)</p> <p>Response to Issues and Directives (10)</p> <p>SPCS Protection System (11) Response to Power Swings</p> <p>Draft RSAW</p>	<p>Ballot and Non-binding Poll</p> <p>Updated Info&gt;&gt; (12) Info&gt;&gt; (13) Vote&gt;&gt;</p>	<p>05/30/14 - 06/09/14 (closed)</p>	<p>Summary&gt;&gt; (15)</p> <p>Ballot Results&gt;&gt; (16)</p> <p>Non-Binding Poll Results&gt;&gt; (17)</p>	<p>Consideration of Comments&gt;&gt; (19)</p>
<p>Comment Period</p> <p>Info&gt;&gt; (14)</p> <p>Submit Comments&gt;&gt;</p>	<p>04/25/14 - 06/09/14 (closed)</p>	<p>Comments Received&gt;&gt; (18)</p>		
<p>Join Ballot Pool&gt;&gt;</p>	<p>04/25/14 - 5/27/14 (closed)</p>			
<p>SAR for Relay Loadability Order 733 Draft SAR Version 1 (1)</p> <p><b>Supporting Materials:</b></p>	<p>Comment Period</p> <p>Info&gt;&gt; (3)</p> <p>Submit Comments&gt;&gt;</p>	<p>08/19/10 - 09/19/10 (closed)</p>	<p>Comments Received&gt;&gt; (4)</p>	<p>Consideration of Comments (5)</p>

Comment Form  
(Word) (2)

--	--	--	--	--

## Standard Authorization Request Form

Title of Proposed Standard	Relay Loadability Order 733
Request Date	8/5/2010
SC Approval Date	8/12/2010

<b>SAR Requester Information</b>		<b>SAR Type</b> ( <i>Check a box for each one that applies.</i> )	
Name	Stephanie Monzon	<input checked="" type="checkbox"/>	New Standard
Primary Contact	Stephanie.monzon@nerc.net	<input checked="" type="checkbox"/>	Revision to existing Standard
Telephone	610-608-8084	<input type="checkbox"/>	Withdrawal of existing Standard
Fax			
E-mail	Stephanie.monzon@nerc.net	<input type="checkbox"/>	Urgent Action



**Purpose** As the ERO, NERC must address all directives in Orders issued by FERC. On March 18, 2010 FERC issued Order No. 733 which approved Reliability Standard PRC-023-1 – Transmission Relay Loadability, and also directed NERC, as the Electric Reliability Organization (“ERO”), to develop certain modifications to the PRC-023-1 standard through its Reliability Standards development process, to be completed by specific deadlines. Attachment 1 to the SAR contains the directives and associated deadlines. The Order also directed development of two new Reliability Standards to address issues related to generator relay loadability and the operation of protective relays due to power swings. The standards-related directives in Order 733 are aimed at closing some reliability-related gaps in the scope of PRC-023-1.

**Industry Need**

FERC directed NERC to develop modifications related to Relay Loadability by specific deadlines in Order No. 733. Attachment 1 to the SAR contains the directives and associated deadlines.

PRC-023-1 Directed Modifications

The Commission directed a number of changes to the approved standard including a test to be applied by Planning Coordinators to determine applicability to elements operated at less than 200 kV. This test will be included in PRC-023-1 either in the form of a Requirement or as an attachment to the standard.

Generator Step-up and Auxiliary Transformers

The Commission directed the ERO to develop a new Reliability Standard addressing generator relay loadability, with its own individual timeline, and not a revision to an existing Standard.

Protective Relays Operating Unnecessarily Due to Stable Power Swings

The Commission observed that PRC-023-1 does not address stable power swings, and pointed out that currently available protection applications and relays, such as pilot wire differential, phase comparison and blinder-blocking applications and relays, and impedance relays with non-circular operating characteristics, are demonstrably less susceptible to operating unnecessarily because of stable power swings. Given the availability of alternatives, the Commission stated that the use of protective relay systems that cannot differentiate between faults and stable power swings constitutes miscoordination of the protection system and is inconsistent with entities’ obligations under existing Reliability Standards.

In this Final Rule the Commission decided not to direct the ERO to modify PRC-023-1 to address stable power swings. However, because both NERC and the U.S.-Canada Power System Outage Task Force have identified undesirable relay operation due to stable power swings as a reliability issue, the Commission directed the ERO to develop a Reliability Standard that requires use of protective relay systems that can differentiate between faults and stable power swings and, when necessary, phases out protective relays that cannot meet this requirement.

**Brief Description**

This SAR’s scope includes three standard development phases to address the standards-related directives in Order No. 733 directives. Phase I is focused on making the specific modifications to PRC-023-1 that were identified in the order; Phase II is focused on

developing a new standard to address generator relay loadability; and Phase III is focused on developing requirements that address protective relay operations due to power swings.

**Detailed Description**

Phase I: Develop modifications to PRC-023-1- Transmission Relay Loadability by March 18, 2011 to address the following directives from Order 733:

- p. 60 . . . modify PRC-023-1 to apply an “add in” approach to sub-100 kV facilities that are owned or operated by currently-Registered Entities or entities that become Registered Entities in the future, and are associated with a facility that is included on a critical facilities list defined by the Regional Entity.
- p. 69 . . . modify Requirement R3 of the Reliability Standard to specify the test that planning coordinators must use to determine whether a sub-200 kV facility is critical to the reliability of the Bulk-Power System.
- p 162 . . . consider “islanding” strategies that achieve the fundamental performance for all islands in developing the new Reliability Standard addressing stable power swings.
- p. 186 . . . require that transmission owners, generator owners, and distribution providers give their transmission operators a list of transmission facilities that implement sub-requirement R1.2.
- p. 203 . . . modify sub-requirement R1.10 so that it requires entities to verify that the limiting piece of equipment is capable of sustaining the anticipated overload for the longest clearing time associated with the fault.
- p. 237 . . . modify the Reliability Standard to add the Regional Entity to the list of entities that receive the critical facilities list. [sub-requirement R3.3]
- p. 244 . . . include section 2 of Attachment A in the modified Reliability Standard as an additional Requirement with the appropriate violation risk factor and violation severity level.
- p. 264 . . . revise section 1 of Attachment A to include supervising relay elements on the list of relays and protection systems that are specifically subject to the Reliability Standard.
- p. 283 . . . modify the Reliability Standard to include an implementation plan for sub-100 kV facilities.
- p. 284 . . . remove the exceptions footnote from the “Effective Dates” section.

In Phase I of the project, the NERC Relay Loadability standard drafting team will either modify the PRC-023-1 Reliability Standard to incorporate the directed modifications or will propose equally efficient and effective alternative approaches that address the Commission’s reliability-related concerns. *(In parallel with this effort, NERC plans to convene a panel of industry subject matter experts to develop a straw man proposal for the test Planning Coordinators must use to identify sub-200 kV facilities that are critical to the reliability of the Bulk Power System. The panel will collect industry feedback on the straw man test using the current standards development process that will be incorporated into Requirement R3 of PRC-023-1 by the Standard Drafting Team.)*

Phase II: Develop a new Standard Addressing Generator Relay Loadability

In Phase II of the project, a new Reliability Standard will be developed by the end of 2012 to address the subject of generator relay loadability in support of NERC’s filing indicating it would develop such a standard and to address the following directive from Order No. 733:

- p. 108 . . . consider the PSEG Companies’ suggestion in developing a Reliability

Standard that addresses generator relay loadability.

As indicated in NERC's Order No. 733 clarification and rehearing request, NERC believes adding additional requirements to the PRC-023 standard in addition to developing a new Reliability Standard to address generator relay loadability could lead to confusion over applicability and the possibility of conflicting requirements. Therefore, NERC proposed in its clarification and rehearing request to address the issue of generator relay loadability in a new Reliability Standard, separate and distinct from the PRC-023 Reliability Standard, which is intended to address relays that protect transmission elements. Subject to the Commission's response to NERC's pending clarification and rehearing request, NERC plans to address generator relay loadability in a new Reliability Standard for applications where the relays are set with a shorter reach to protect the generator and the generator step-up transformer, and for applications where the relays are set with a longer reach to provide backup protection for transmission system faults. The standard drafting team will use relevant sections of the NERC technical reference document, Power Plant and Transmission System Protection Coordination Section 3.1 and Appendix E to develop the requirements by which generator relay loadability will be assessed.

Phase III: Development of a New Standard Addressing the Issue of Protective Relay Operations Due To Power Swings

In Phase III of the project, a new Reliability Standard will be developed to address the subject of protective relay operations due to power swings to address the following directive from Order No. 733 by the end of 2014:

- p. 150 - develop a Reliability Standard that requires the use of protective relay systems that can differentiate between faults and stable power swings and, when necessary, phases out protective relay systems that cannot meet this requirement.

**Standards Authorization Request Form**

**Reliability Functions**

<b>The Standard will Apply to the Following Functions</b> <i>(Check box for each one that applies.)</i>		
<input type="checkbox"/>	Reliability Assurer	Monitors and evaluates the activities related to planning and operations, and coordinates activities of Responsible Entities to secure the reliability of the bulk power system within a Reliability Assurer Area and adjacent areas.
<input checked="" type="checkbox"/>	Reliability Coordinator	Responsible for the real-time operating reliability of its Reliability Coordinator Area in coordination with its neighboring Reliability Coordinator's wide area view.
<input type="checkbox"/>	Balancing Authority	Integrates resource plans ahead of time, and maintains load-interchange-resource balance within a Balancing Authority Area and supports Interconnection frequency in real time.
<input type="checkbox"/>	Interchange Authority	Ensures communication of interchange transactions for reliability evaluation purposes and coordinates implementation of valid and balanced interchange schedules between Balancing Authority Areas.
<input checked="" type="checkbox"/>	Planning Coordinator	Assesses the longer-term reliability of its Planning Coordinator Area.
<input type="checkbox"/>	Resource Planner	Develops a >one year plan for the resource adequacy of its specific loads within its portion of the Planning Coordinator's Area.
<input checked="" type="checkbox"/>	Transmission Owner	Owns and maintains transmission facilities.
<input type="checkbox"/>	Transmission Operator	Ensures the real-time operating reliability of the transmission assets within a Transmission Operator Area.
<input type="checkbox"/>	Transmission Planner	Develops a >one year plan for the reliability of the interconnected Bulk Electric System within the Transmission Planner Area.
<input type="checkbox"/>	Transmission Service Provider	Administers the transmission tariff and provides transmission services under applicable transmission service agreements (e.g., the pro forma tariff).
<input checked="" type="checkbox"/>	Distribution Provider	Delivers electrical energy to the End-use customer.
<input checked="" type="checkbox"/>	Generator Owner	Owns and maintains generation facilities.
<input type="checkbox"/>	Generator Operator	Operates generation unit(s) to provide real and reactive power.
<input type="checkbox"/>	Purchasing-Selling Entity	Purchases or sells energy, capacity, and necessary reliability-related services as required.
<input type="checkbox"/>	Load-Serving Entity	Secures energy and transmission service (and reliability-related services) to serve the End-use Customer.

***Reliability and Market Interface Principles***

<b>Applicable Reliability Principles</b> <i>(Check box for all that apply.)</i>	
<input checked="" type="checkbox"/>	1. Interconnected bulk power systems shall be planned and operated in a coordinated manner to perform reliably under normal and abnormal conditions as defined in the NERC Standards.
<input type="checkbox"/>	2. The frequency and voltage of interconnected bulk power systems shall be controlled within defined limits through the balancing of real and reactive power supply and demand.
<input checked="" type="checkbox"/>	3. Information necessary for the planning and operation of interconnected bulk power systems shall be made available to those entities responsible for planning and operating the systems reliably.
<input type="checkbox"/>	4. Plans for emergency operation and system restoration of interconnected bulk power systems shall be developed, coordinated, maintained and implemented.
<input type="checkbox"/>	5. Facilities for communication, monitoring and control shall be provided, used and maintained for the reliability of interconnected bulk power systems.
<input type="checkbox"/>	6. Personnel responsible for planning and operating interconnected bulk power systems shall be trained, qualified, and have the responsibility and authority to implement actions.
<input type="checkbox"/>	7. The security of the interconnected bulk power systems shall be assessed, monitored and maintained on a wide area basis.
<input type="checkbox"/>	8. Bulk power systems shall be protected from malicious physical or cyber attacks.
<b>Does the proposed Standard comply with all of the following Market Interface Principles?</b> <i>(Select 'yes' or 'no' from the drop-down box.)</i>	
1. A reliability standard shall not give any market participant an unfair competitive advantage. Yes	
2. A reliability standard shall neither mandate nor prohibit any specific market structure. Yes	
3. A reliability standard shall not preclude market solutions to achieving compliance with that standard. Yes	
4. A reliability standard shall not require the public disclosure of commercially sensitive information. All market participants shall have equal opportunity to access commercially non-sensitive information that is required for compliance with reliability standards. Yes	

**Standards Authorization Request Form**

---

***Related Standards***

<b>Standard No.</b>	<b>Explanation</b>
PRC-023-1	Order No. 733 approved Reliability Standard PRC-023-1 – Transmission Relay Loadability, and directed NERC, as the Electric Reliability Organization (“ERO”), to develop certain modifications to the PRC-023-1 standard through its Reliability Standards development process, to be completed by specific deadlines.
New Reliability Standard	Development of a New Standard Addressing Generator Relay Loadability
New Reliability Standard	Development of a New Standard Addressing the Issue of Protective Relay Operations Due To Power Swings

***Related SARs***

<b>SAR ID</b>	<b>Explanation</b>

***Regional Variances***

<b>Region</b>	<b>Explanation</b>
ERCOT	
FRCC	
MRO	
NPCC	
SERC	
RFC	
SPP	
WECC	

## Attachment 1 - Order No. 733 – Action Plan and Timetable

Order No. 733 approved Reliability Standard PRC-023-1 – Transmission Relay Loadability, and directed NERC, as the Electric Reliability Organization (“ERO”), to develop certain modifications to the PRC-023-1 standard through its Reliability Standards development process, to be completed by specific deadlines and directed NERC to develop requirements to address issues related to Relay Loadability. The Order also directed development of two new Reliability Standards to address issues related to generator relay loadability and the operation of protective relays due to power swings. The following table lists the FERC directives in Order No. 733 and for each directive associates it with a project phase. Note that some of the tasks within each phase will be managed by NERC staff, not the standard drafting team.

Note that the scope of the SAR is limited to addressing the directives highlighted in the table below.

Paragraph	Text	Project Phase/ Timeline
60	With respect to sub-100 kV facilities, we adopt the NOPR proposal and direct the ERO to modify PRC-023-1 to apply an “add in” approach to sub-100 kV facilities that are owned or operated by currently-Registered Entities or entities that become Registered Entities in the future, and are associated with a facility that is included on a critical facilities list defined by the Regional Entity. We also direct that additions to the Regional Entities’ critical facility list be tested for their applicability to PRC-023-1 and made subject to the Reliability Standard as appropriate.	Phase I -- by March 18, 2011
69	Finally, pursuant to section 215(d)(5) of the FPA, we direct the ERO to modify Requirement R3 of the Reliability Standard to specify the test that planning coordinators must use to determine whether a sub-200 kV facility is critical to the reliability of the Bulk-Power System. We direct the ERO to file its test, and the results of applying the test to a representative sample of utilities from each of the three Interconnections, for Commission approval no later than one year from the date of this Final Rule.	Phase I -- Note NERC’s pending request for rehearing filed on April 19, 2010 regarding this directive.
97	Finally, commenters argue that there should be some mechanism for entities to challenge criticality determinations. We agree that such a mechanism is appropriate and direct the ERO to develop an appeals process (or point to a process in its existing procedures) and submit it to the Commission no later than one year after the date of this Final Rule.	Phase I – by March 18, 2011
105	In light of the ERO’s statement that within two years it expects to submit to the Commission a proposed Reliability Standard addressing generator relay loadability, we direct the ERO to submit to the Commission an updated and specific timeline explaining when it expects to develop and submit this proposed Standard.	Phase II – by the end of 2012
108	Finally, the PSEG Companies suggest that the ERO consider whether a generic rating percentage can be established for generator step-up transformers and, if so, determine that percentage. Although we do not adopt the NOPR proposal, we encourage the ERO to consider the PSEG Companies’ suggestion in developing a Reliability Standard that addresses generator relay loadability.	Phase II – by the end of 2012
150	However, because both NERC and the Task Force have identified undesirable relay operation due to stable power swings as a reliability issue, we direct the ERO to develop a Reliability Standard that requires the use of protective relay systems that can differentiate between faults and stable power swings and,	Phase III – by the end of 2014

## Attachment 1 - Order No. 733 – Action Plan and Timetable

Paragraph	Text	Project Phase/ Timeline
	when necessary, phases out protective relay systems that cannot meet this requirement. We also direct the ERO to file a report no later than 120 days of this Final Rule addressing the issue of protective relay operation due to power swings. The report should include an action plan and timeline that explains how and when the ERO intends to address this issue through its Reliability Standards development process.	
162	We agree with the PSEG Companies and direct the ERO to consider “islanding” strategies that achieve the fundamental performance for all islands in developing the new Reliability Standard addressing stable power swings.	Phase I – by March 18, 2011
186	However, we will adopt the NOPR proposal to direct the ERO to modify PRC-023-1 to require that transmission owners, generator owners, and distribution providers give their transmission operators a list of transmission facilities that implement sub-requirement R1.2.	Phase I – by March 18, 2011
203	We adopt the NOPR proposal and direct the ERO to modify sub-requirement R1.10 so that it requires entities to verify that the limiting piece of equipment is capable of sustaining the anticipated overload for the longest clearing time associated with the fault.	Phase I – by March 18, 2011
224	While we are not adopting the NOPR proposal, we direct the ERO to document, subject to audit by the Commission, and to make available for review to users, owners and operators of the Bulk-Power System, by request, a list of those facilities that have protective relays set pursuant sub-requirement R1.12.	Phase I – by March 18, 2011
237	We adopt the NOPR proposal and direct the ERO to modify the Reliability Standard to add the Regional Entity to the list of entities that receive the critical facilities list. [sub-requirement R3.3]	Phase I – by March 18, 2011
244	We adopt the NOPR proposal and direct the ERO to include section 2 of Attachment A in the modified Reliability Standard as an additional Requirement with the appropriate violation risk factor and violation severity level.	Phase I – by March 18, 2011
264	After further consideration, and in light of the comments, we will not direct the ERO to remove any exclusion from section 3, except for the exclusion of supervising relay elements in section 3.1. Consequently, we direct the ERO to revise section 1 of Attachment A to include supervising relay elements on the list of relays and protection systems that are specifically subject to the Reliability Standard.	Phase I – by March 18, 2011
283	Additionally, in light of our directive to the ERO to expand the Reliability Standard’s scope to include sub-100 kV facilities that Regional Entities have already identified as necessary to the reliability of the Bulk-Power System through inclusion in the Compliance Registry, we direct the ERO to modify the Reliability Standard to include an implementation plan for sub-100 kV facilities.	Phase I – by March 18, 2011



## Attachment 1 - Order No. 733 – Action Plan and Timetable

Paragraph	Text	Project Phase/ Timeline
284	We also direct the ERO to remove the exceptions footnote from the “Effective Dates” section.	Phase I – by March 18, 2011
297	Finally, we direct the ERO to assign a “high” violation risk factor to Requirement R3.	Filed with the Commission on April 19, 2010
308	Consequently, we direct the ERO to assign a single violation severity level of “severe” for violations of Requirement R1.	Filed with the Commission on April 19, 2010
310	Accordingly, we direct the ERO to change the violation severity level assigned to Requirement R2 from “lower” to “severe” to be consistent with Guideline 2a.	Filed with the Commission on April 19, 2010
311	Finally, we direct the ERO to assign a “severe” violation severity level to Requirement R3.	Filed with the Commission on April 19, 2010

## Unofficial Comment Form for Relay Loadability Order (No. 733) (Project 2010-13)

Please **DO NOT** use this form. Please use the electronic form located at the link below to submit comments on the proposed standard, PRC-023-2 and on the associated SAR. The electronic comment form must be completed **by September 19, 2010**.

<https://www.nerc.net/nercsurvey/Survey.aspx?s=c64a2b0a1f9d4e98aef8640932516830>

If you have questions please contact Stephanie Monzon at Stephanie.monzon@nerc.net or by telephone at [610-608-8084

Project 2010-13: Relay Loadability Order (RLO SDT) – PRC-023-2

### Background Information

NERC Standard PRC-023-1 – Transmission Relay Loadability was approved by FERC as mandatory and enforceable in March 2010, with direction that NERC make a number of changes.

The Standard Drafting Team has made changes to PRC-023 to address the following directives from Order 733

- p. 60 . . . modify PRC-023-1 to apply an “add in” approach to sub-100 kV facilities that are owned or operated by currently-Registered Entities or entities that become Registered Entities in the future, and are associated with a facility that is included on a critical facilities list defined by the Regional Entity.
- p. 186 . . . require that transmission owners, generator owners, and distribution providers give their transmission operators a list of transmission facilities that implement sub-requirement R1.2.
- p. 203 . . . modify sub-requirement R1.10 so that it requires entities to verify that the limiting piece of equipment is capable of sustaining the anticipated overload for the longest clearing time associated with the fault. • p. 224 . . . make available for review to users, owners and operators of the Bulk-Power System, by request, a list of those facilities that have protective relays
- p. 237 . . . modify the Reliability Standard to add the Regional Entity to the list of entities that receive the critical facilities list. [sub-requirement R3.3]
- p. 244 . . . include section 2 of Attachment A in the modified Reliability Standard as an additional Requirement with the appropriate violation risk factor and violation severity level.
- p. 264 . . . revise section 1 of Attachment A to include supervising relay elements on the list of relays and protection systems that are specifically subject to the Reliability Standard.
- p. 283 . . . modify the Reliability Standard to include an implementation plan for sub-100 kV facilities.
- p. 284 . . . remove the exceptions footnote from the “Effective Dates” section.

## Unofficial Comment Form for Relay Loadability Order (No. 733) (Project 2010-13)

---

However, the directive below is not yet addressed, even though it is referenced within the draft standard text. It will be included in a subsequent posting of this draft standard.

- p. 69 . . . modify Requirement R3 of the Reliability Standard to specify the test that planning coordinators must use to determine whether a sub-200 kV facility is critical to the reliability of the Bulk-Power System.

To expedite the project to address the directives from FERC Order No. 733, the Standard Drafting Team is posting the draft modifications to PRC-023-1 for an informal comment period.

Please note that the posting of PRC-023-2 is an **INFORMAL** posting.

**Unofficial Comment Form for Relay Loadability Order (No. 733) (Project 2010-13)**

---

1. The Applicability Section (4.1.2 and 4.1.4) and Requirement R5 (previously Requirement R3) have been modified to address the directive in Paragraph 60 of Order no. 733. Do you agree that this is an acceptable and effective method of meeting this directive? If not, please explain.

Yes

No

Comments:

2. Requirement R1 has been modified to address the directive in Paragraph 244 of Order no. 733. Do you agree that this is an acceptable and effective method of meeting this directive? If not, please explain.

Yes

No

Comments:

3. Requirement R1, section 10 has been modified to address the directive in Paragraph 203 of Order no. 733. Do you agree that this is an acceptable and effective method of meeting this directive? If not, please explain.

Yes

No

Comments:

4. Requirement R3 has been added to address the directive in Paragraph 186 of Order no. 733. Do you agree that this is an acceptable and effective method of meeting this directive? If not, please explain.

Yes

No

Comments:

5. Requirement R4 has been added to address the directive in Paragraph 224 of Order no. 733. Do you agree that this is an acceptable and effective method of meeting this directive? If not, please explain.

Yes

No

Comments:

6. Requirement R5 and part 5.1 (previously Requirement R3 and part 3.1) have been modified to establish the framework to address the directive in Paragraph 69 of Order no. 733, although the criteria itself (which will be Attachment B) is still being

**Unofficial Comment Form for Relay Loadability Order (No. 733) (Project 2010-13)**

---

developed. Do you agree that this is an acceptable and effective method of meeting this directive considering that Requirement R5 is establishing the construct to insert the criteria at a future time in the form of Attachment B? If not, please explain.

Yes

No

Comments:

7. Attachment A has been modified to address the directive in Paragraph 264 of Order no. 733. Do you agree that this is an acceptable and effective method of meeting this directive? If not, please explain.

Yes

No

Comments:

8. Do you agree that the SDT has addressed the remaining directives: Paragraph 284 to remove the footnote and Paragraph 283 to modify the implementation plan for sub-100 kV facilities (by revising the Effective Date section of the standard)?

Yes

No

Comments:

**Questions 9-13 relate to the SAR**

9. Do you agree that the scope of the proposed standards action addresses the directive or directives?

Yes

No

Comments:

10. Can you identify an equally efficient and effective method of achieving the reliability intent of the directive or directives?

Yes

No

Comments:

11. Do you agree with the scope of the proposed standards action?

Yes

No

Comments:

12. Are you aware of any regional variances that we should consider with this SAR?

Yes

No

Comments:

13. Are you aware of any associated business practices that we should consider with this SAR?

Yes

No

Comments:



## Standards Announcement

Standards Authorization Request (SAR) and Draft Standard  
Formal and Informal Comment Periods Open  
August 19–September 19, 2010

### Now available at:

[http://www.nerc.com/filez/standards/Reliability\\_Standards\\_Under\\_Development.html](http://www.nerc.com/filez/standards/Reliability_Standards_Under_Development.html)

### Project 2010-13: Revisions to Relay Loadability for Order 733

The drafting team associated with this project is seeking comments on a proposed SAR and an initial set of proposed requirements **until 8 p.m. Eastern on September 19, 2010.**

The SAR is being posted for a 30-day formal comment period and the standard is being posted for a 30-day informal comment period; comments on both the SAR and the proposed requirements will be collected using a single comment form.

### Instructions

Please use this [electronic form](#) to submit comments. If you experience any difficulties in using the electronic form, please contact Monica Benson at [monica.benson@nerc.net](mailto:monica.benson@nerc.net). An off-line, unofficial copy of the comment form is posted on the project page:

[http://www.nerc.com/filez/standards/SAR\\_Project%202010-13\\_Order%20733%20Relay%20Modifications.html](http://www.nerc.com/filez/standards/SAR_Project%202010-13_Order%20733%20Relay%20Modifications.html)

### Next Steps

The drafting team will draft and post responses to comments received during this period.

- The SAR is being posted for a 30-day formal comment period. With a formal comment period the team is required to provide a response to each comment submitted.
- The proposed requirements in the standard are being posted for a 30-day informal comment period. With an informal comment period, for each question asked on the comment form, the drafting team will provide a summary response to indicate whether stakeholders support the proposed revision and to identify any additional changes made based on stakeholder comments. The team will not provide an individual response to each comment submitted.

### Project Background

When FERC issued Order 733, approving PRC-023-1 — Transmission Relay Loadability, it directed several changes to that standard and also directed development of one or more new standards within specified time periods. NERC filed for clarification and rehearing asking for clarity and an extension of time to address the directives, however without a response to the

requests for clarification and rehearing, NERC must progress as though these requests will be denied.

The SAR for Project 2010-13 subdivides the standard development related directives into three phases. Phase I addresses the specific directives from Order 733 that identified required modifications to various elements within PRC-023-1. Phase II addresses directives associated with development of a new standard to address generator relay loadability. Phase III addresses directives associated with writing requirements to address protective relay operations due to power swings.

### **Applicability of Proposed PRC-023-2**

Distribution Providers that own specific facilities (see standard for details)

Generator Owners that own specific facilities (see standard for details)

Planning Coordinators

Transmission Owners that own specific facilities (see standard for details)

### **Standards Development Process**

The [Reliability Standards Development Procedure](#) contains all the procedures governing the standards development process. The success of the NERC standards development process depends on stakeholder participation. We extend our thanks to all those who participate.



- Individual or group. (36 Responses)
- Name (20 Responses)
- Organization (20 Responses)
- Group Name (15 Responses)
- Lead Contact (15 Responses)
- Question 1 (32 Responses)
- Question 1 Comments (36 Responses)
- Question 2 (29 Responses)
- Question 2 Comments (36 Responses)
- Question 3 (29 Responses)
- Question 3 Comments (36 Responses)
- Question 4 (29 Responses)
- Question 4 Comments (36 Responses)
- Question 5 (27 Responses)
- Question 5 Comments (36 Responses)
- Question 6 (32 Responses)
- Question 6 Comments (36 Responses)
- Question 7 (32 Responses)
- Question 7 Comments (36 Responses)
- Question 8 (26 Responses)
- Question 8 Comments (36 Responses)
- Question 9 (27 Responses)
- Question 9 Comments (36 Responses)
- Question 10 (25 Responses)
- Question 10 Comments (36 Responses)
- Question 11 (27 Responses)
- Question 11 Comments (36 Responses)
- Question 12 (29 Responses)
- Question 12 Comments (36 Responses)
- Question 13 (29 Responses)
- Question 13 Comments (36 Responses)

-
Individual
Gene Henneberg
NV Energy
Yes
No
The proposed phrase added to R1 is only a start: “. . . , and to prevent its out-of-step blocking schemes from blocking tripping for fault conditions.” The specific wording proposed by the Drafting Team may prevent using the out-of-step-block functions of many modern and widely used line protection relays (e.g. SEL-321 and later models and GE-UR). These relay’s OSB function first blocks the protection elements from tripping, then uses a short delay and/or other information to determine whether the observed and perhaps evolving condition really represents a fault, in which case the blocking is reset to allow tripping. Such a block/reset operation is the most common technology available and would appear to lie within the intent of FERC in paragraph 244, but could be excluded by the presently proposed language. If an out-of-step blocking phrase is inserted in Requirement R1 of the standard, the emphasis should be modified to read something like: “. . . , and its out-of-step blocking schemes must allow tripping for fault conditions.” This standard should also require that out-of-step blocking settings coordinate with both the loadability and protection characteristics. The out-of-step blocking references would seem to fit best within the organization of the standard if included as a new Requirement R2 (FERC’s paragraph 244 anticipates “. . . an additional Requirement . . .”), with re-numbering of the proposed R2 through R5 as R3 through R6. The essential content of the DT’s proposed phrase in R1 would be included as part of this new R2, which would read something like: R2. Each Transmission Owner, Generator Owner, and Distribution Provider shall evaluate its out-of-step blocking schemes to ensure that both: R2.1. Out-of-step blocking schemes allow tripping for fault conditions during the loading conditions determined from Requirement R1 parts R1.1 through R1.13. R2.2. Relay out-of-step blocking settings coordinate with both the relay loadability characteristic determined from Requirement R1 parts R1.1 through R1.13 and the facility protection settings. The Measure for this proposed R2 would read something like: M2.The Transmission Owner, Generator Owner, and Distribution Provider with out-of-step blocking schemes shall have evidence such as spreadsheets or summaries of calculations to show that each of its out-of-step blocking schemes is set to comply with the requirements of R2.1 and R2.2. The VSL for R1 would not change; specifically it would not reference out-of-step blocking schemes. The VSL for this proposed new R2 would be “Severe” and read something like: A Transmission Owner, Generator Owner, or Distribution Provider did not allow its out-of-step blocking schemes to trip for fault conditions during the loading conditions determined from Requirement R1 parts R1.1 through R1.13. OR A Transmission Owner, Generator Owner, or Distribution Provider did not coordinate operation of its out-of-steo blocking schemes with both the relay

loadability characteristic determined from Requirement R1 parts R1.1 through R1.13 and the facility protection settings.
Yes
Yes
Yes
No
This approach is not yet an acceptable and effective method of meeting the directive of paragraph 69. Whether it becomes an acceptable and effective method of meeting the directive will depend on the content of Attachment B. I'll reserve specific judgment and concerns until Attachment B is available for comment.
Yes
Yes
Yes
No
NERC's proposed Phase I, II, III process seems reasonable.
Yes
No
Individual
Steve Wadas
NPPD
Yes
As long as you keep BES.
Yes
I'm ok with that. It could have easily been left in Attachment A. You didn't bring the other language from attachment A to R1. You could of created a separate requirement for OOS, but I'm fine with moving it to R1.
No
Setting the relay to 150% of a 336MVA or 500MVA transformer can force you to cross the transformer damage curve and now your transformer is at risk to loss of life.
Yes
Yes
No
Attachment B has not even been developed.
No
Please remove Attachment A, R1.6. "Protective functions that supervise operation of other protection functions in 1.1 through 1.5.". If you do not remove R1.6 you must provide a detailed explanation of what supervise operation means and give examples. Utilities have thousands of relays that have imbedded fault detective supervision overcurrents for phase distance elements that are set at 0.5 amps or some similar value. This can not be changed. From your requirement these utilities would have to replace all of these relays or we would have to lower the Facility rating to 0.5 amp secondary/150%. You are also stating that if we have an external phase overcurrent fault detector that supervises a phase distance relay that this fault detector must now have to meet Requirement 1. This is an unacceptable requirement if this is your intent. You are putting the system at risk if this is your intent. We must set our relays to protect the line. We must also set fault detectors to pickup for all faults considering N-1 conditions at a minimum where the strongest source must be remove and the relays must still clear the fault. Please do not lose focus of the purpose: "Protective relay settings shall be set to reliably detect all fault conditions and protect the electrical network from these faults". If you have questions on my comments feel free to contact me. Steve Wadas, NPPD, 402 563 5917 Wk.
Yes
No
No
No

No
Yes
See Question 7.
Group
E.ON U.S. LLC
Brent Ingebrigtsen
No
E.ON U.S. believes that it is confusing the way R5 is currently written due to the last part of the sentence "... when protective relay settings limit transmission loadability." There is a need for clarification on how this is to be applied. As an alternative: If the directive is to have the Planning Coordinator determine which sub-100kV facilities should be subject to the Reliability Standard; R5 should be modified to read "Each Planning Coordinator shall apply the criteria in Attachment B to determine which of the facilities in its Planning Coordinator Area are to be included in 4.1.2 and 4.1.4."
No
Since correct operation of the out-of-step blocking feature is integral to and only a single component of a successful trip operation (for fault conditions), this is already included in the requirement to "maintain reliable protection of the BES for all fault conditions" and does not have to be mentioned separately. Also, R1 (as written) may be interpreted to require one of the settings (1 through 13) to be used to prevent out-of-step blocking schemes from blocking tripping for fault conditions. But Settings 1 thru 13 do not address specific setting criteria for out-of-step blocking.
No
E.ON U.S. is concerned that the proposal requires a fault protection scheme separate from the phase overload relays. With the phase overload relays set at 150% of the maximum transformer nameplate, they (by themselves) will not be able to coordinate with the transformer damage curve (as defined by IEEE) for low level faults. R1, Section 10 meets the directive of Paragraph 203; however it is not clear that Section 10 only applies when there is no high side breaker at the transformer, as discussed in Order No. 733. E.ON U.S. recommends that an exclusion of the transmission line relay settings should be considered when transformer overload protection is provided by other means (i.e. A low side breaker trip or a direct transfer trip of the remote breaker initiated by an overload relay installed on the transformer).
Yes
Yes
No
See comments for item #1.
No
E.ON U.S. requests a clarification of "protective functions" such that it applies only to those protective relay elements that would respond to non-fault or load conditions, and could issue a direct trip, upon operation, during a loss of communication or loss of potential condition.
No
Cannot assess the impact until Attachment B is developed and commented sections above are clarified.
No
See commented sections above. Also, the directive identified in Paragraph 224 was not included in the detailed description or highlighted in Attachment 1 of the SAR. However it was included in the proposed modifications as R4.
Yes
No
No
No
Individual
Joylyn Faust
Consumers Energy
Yes
Yes
Yes
Yes
Yes

Yes
We are concerned about the criteria still undergoing development, and will offer any relevant comments on that criteria when it is published.
No
The supervising elements addressed within this change may fundamentally be unable to be set in accordance with the requirements of PRC-023, while still permitting the Protection System to function properly for fault conditions. The supervising element is usually present to assure that a distance element does not operate inadvertently for close-in zero-voltage faults near the relay location in the non-trip direction, but does not, by itself, produce a trip. We appreciate that NERC must respond to this directive, but believe that the change, as expressed, will be detrimental to reliability.
Yes
Yes
Yes
NERC should, again, oppose the FERC directive in paragraph 264, since, as explained above, this directive is both unnecessary and detrimental to reliability.
Yes
No
No
Individual
Jonathan Meyer
Idaho Power - System Protection
Yes
Yes
No
The reworded Requirement should be clarified. The fault level and duration that the limiting element will be exposed can be a function of fault location and contingencies, such as relay failures, that are not addressed or defined. No measure is specified in the reliability standard that will demonstrate compliance with the revised requirements in R1.10.
Yes
Yes
No
It is not acceptable or effective until Attachment B is completed and available for review.
Yes
The order has been met, but there is significant concern about the inclusion of supervisory elements in protective systems. A supervisory element is not performing a tripping function. As stated in Attachment A "This standard includes any protective functions which could trip with or without time delay, on load current, including but not limited to:...". Supervisory elements, used properly, do not trip for load current.
Yes
Yes
No
Yes
No
No
Group
Northeast Power Coordinating Council
Guy Zito
No

The revised Applicability paragraph 4.1.4 reads: 4.1.4 Transformers with low voltage terminals connected below 200 kV as designated by the Planning Coordinator as critical to the reliability of the Bulk Electric System (BES). The phrase "low voltage terminals" is open to interpretation because some transformers have low-voltage terminals which are do not supply a load, or supply only local substation AC service. Sometimes the transformer is a 3-winding bank, with the low-voltage winding not used, or the low-voltage winding is used solely to provide additional grounding, as in the case of a delta-connected tertiary, unconnected to any load. Is this what is intended? If yes, then they should remove the ambiguity. Note the phrase "low-voltage" terminal was part of Revision 1 and is unchanged by Revision 2, however, the new applicability to below 200 kV raises the new concern. What is meant by "critical to the reliability of the Bulk Electric System (BES)"? Also, replace "as designated" with "and designated". Suggest 4.1.4 be revised to read: 4.1.4 Transformers with low voltage terminals connected below 200 kV and designated by the Planning Coordinator as Critical Assets. Clarification is needed to explain the disconnect between FERC's "sub-100kV", and the proposed "below 200kV".

No

The last sentence in R1 should be revised to read: Each Transmission Owner, Generator Owner, and Distribution provider shall evaluate relay loadability at 0.85 per unit voltage, and a power factor angle of 30 degrees. Settings are to be applied as listed following: "Setting" should be replaced throughout R1 when referring to a part, or sub-requirement of R1. The terminology should be whatever is preferred by NERC. Requirement R1, Parts 7, 8 and 9: Requirement R1, Parts 7, 8 and 9, replace the phrase "under any system configuration" with "under any system condition:" 7. Set transmission line relays applied at the load center terminal, remote from generation stations, so they do not operate at or below 115% of the maximum current flow from the load to the generation source under any system condition. 8. Set transmission line relays applied on the bulk system-end of transmission lines that serve load remote to the system so they do not operate at or below 115% of the maximum current flow from the system to the load under any system condition. 9. Set transmission line relays applied on the load-end of transmission lines that serve load remote to the bulk system so they do not operate at or below 115% of the maximum current flow from the [\_\_\_\_] to the under any system condition. [Brackets added, also see further comment on missing wording following] This phrase "under any system configuration" could be construed as being too all-inclusive, as one could postulate multiple events, e.g., simultaneous outages, which however unlikely could permit power flows in a direction for which the system was not originally designed. As with the second comment below, the phrase "under any system condition" was part of Revision 1 and is unchanged by Revision 2, however, the new applicability to below 200 kV creates the new concern. Requirement 1, part 9: As currently written, Requirement 1, part 9 states: 9. Set transmission line relays applied on the load-end of transmission lines that serve load remote to the bulk system so they do not operate at or below 115% of the maximum current flow from the [\_\_\_\_] to the under any system configuration. [Brackets added] Some words are missing. The brackets have been added above to show one place where at least some of the needed wording may be missing. A rewrite is necessary in order for this sentence to make any sense.

Yes

No

Referring to the response to Question 2 above, "Setting" should be replaced with Part, or Sub-requirement, whichever is the terminology preferred by NERC to use.

No

R4 addresses the directive, but as commented on previously, "Setting" should be replaced with Part, or Sub-requirement, whichever is the terminology preferred by NERC to use.

No

Requirement R5 states that the Planning Coordinator will determine which facilities below 200kV are critical to the reliability of the Bulk Electric System by applying criteria defined in Attachment B, which is to be developed. Therefore, respondents cannot comment on Attachment B. Respondents reserve the right to comment when Attachment B is available for review. Because the document has been presented to the industry without Attachment B, how will Attachment B be presented to the industry? Regarding sub-requirement 5.3, it must be revised to clarify that the Planning Coordinator will provide the list of facilities subject to the Standard to all of the TOs, GOs, and DPs registered in its footprint, not just to those entities that have facilities on the list. 5.2 refers to "Part 1". As commented on previously in Question 5 and elsewhere, Part or Sub-requirement should be used for consistency.

Yes

Yes

Yes

No

Yes

No

No

Individual

Michael Gammon

Kansas City Power & Light

No
Agree the changes for 4.1.2 and 4.1.4 are effective in meeting the “add in” approach in the FERC order. However, do not agree with the approach in R5. R5 proposes to establish the criteria by which Reliability Coordinators will determine facilities critical to the reliability of the BES. There are a variety of differing, and often complex, operating conditions that dictate the need for transmission facilities. The TPL standards require extensive studies of the transmission system be performed under steady state and dynamic conditions to understand and identify sensitive areas of the transmission system and enable Reliability Coordinators to identify flowgates in their respective regions. In light of the Reliability Coordinators awareness of transmission sensitivities through these studies, it seems unnecessary to dictate to the Reliability Coordinators additional criteria.
Yes
No
Although setting #10 includes language to protect the most limiting element for a transmission circuit ending with a transformer, the relay settings in the bulleted items are absent any consideration for other elements such as disconnect switches, wave traps, current transformers, potential transformers, etc. and are only with concern to the transformer. The relay settings should consider the fault current capabilities of all the facilities involved and be set in magnitude and duration of the lowest facility rating.
No
Do not agree that the Regional Entity be included as a recipient of the list of transmission facilities. By NERC definition, the Regional Entity is the Compliance Monitor and Enforcement Authority for the NERC Reliability Standards and is not an operating entity. It is inappropriate to include Regional Entities as an entity to provide this information outside of the audit process established by the NERC Rules of Procedure. By definition, in the NERC Reliability Terminology, the Regional Entity is a compliance enforcement agent and not an operating organization of the Bulk Power System, and, therefore, has no operating reason to obtain this information. See definition below: Regional Entity – The term ‘regional entity’ is defined in Section 215 of the Federal Power Act means an entity having enforcement authority pursuant to subsection (e)(4) [of Section 215]. A regional entity (RE) is an entity to which NERC has delegated enforcement authority through an agreement approved by FERC. There are eight RE’s. The regional entities were formed by the eight North American regional reliability organizations to receive delegated authority and to carry out compliance monitoring and enforcement activities. The regional entities monitor compliance with the standards and impose enforcement actions when violations are identified.
No
The proposed R4 exceeds the concerns of FERC in this matter. FERC directed a requirement to provide information upon request. The proposed R4 requires data submission without request of the parties with interest to the information. Recommend the SDT consider modifying this requirement to provide this information upon the request of appropriate operating parties. Do not agree that the Regional Entity be included as a recipient of the list of transmission facilities. By NERC definition, the Regional Entity is the Compliance Monitor and Enforcement Authority for the NERC Reliability Standards and is not an operating entity. It is inappropriate to include Regional Entities as an entity to provide this information outside of the audit process established by the NERC Rules of Procedure. By definition, in the NERC Reliability Terminology, the Regional Entity is a compliance enforcement agent and not an operating organization of the Bulk Power System, and, therefore, has no operating reason to obtain this information. See definition below: Regional Entity – The term ‘regional entity’ is defined in Section 215 of the Federal Power Act means an entity having enforcement authority pursuant to subsection (e)(4) [of Section 215]. A regional entity (RE) is an entity to which NERC has delegated enforcement authority through an agreement approved by FERC. There are eight RE’s. The regional entities were formed by the eight North American regional reliability organizations to receive delegated authority and to carry out compliance monitoring and enforcement activities. The regional entities monitor compliance with the standards and impose enforcement actions when violations are identified.
No
Do not agree with the approach in R5 and R5.1. This proposes to establish the criteria by which Reliability Coordinators will determine facilities critical to the reliability of the BES. There are a variety of differing, and often complex, operating conditions that dictate the need for transmission facilities. The TPL standards require extensive studies of the transmission system be performed under steady state and dynamic conditions to understand and identify sensitive areas of the transmission system and enable Reliability Coordinators to identify flowgates in their respective regions. In light of the Reliability Coordinators awareness of transmission sensitivities through these studies, it seems unnecessary to dictate to the Reliability Coordinators additional criteria. In addition, in R5.3, do not agree that the Regional Entity be included as a recipient of the list of transmission facilities. By NERC definition, the Regional Entity is the Compliance Monitor and Enforcement Authority for the NERC Reliability Standards and is not an operating entity. It is inappropriate to include Regional Entities as an entity to provide this information outside of the audit process established by the NERC Rules of Procedure. By definition, in the NERC Reliability Terminology, the Regional Entity is a compliance enforcement agent and not an operating organization of the Bulk Power System, and, therefore, has no operating reason to obtain this information. See definition below: Regional Entity – The term ‘regional entity’ is defined in Section 215 of the Federal Power Act means an entity having enforcement authority pursuant to subsection (e)(4) [of Section 215]. A regional entity (RE) is an entity to which NERC has delegated enforcement authority through an agreement approved by FERC. There are eight RE’s. The regional entities were formed by the eight North American regional reliability organizations to receive delegated authority and to carry out compliance monitoring and enforcement activities. The regional entities monitor compliance with the standards and impose enforcement actions when violations are identified.
Yes
No
It is inappropriate for this standard to supersede any other agreements and the provisions of those agreements that have been established between NERC and Registered Entities. The footnote made it clear those agreements would continue to

be honored. Recommend the SDT reinstate the principles established by the footnote directly into the Effective Dates section to recognize the authority of those agreements. Agree with the effective dates of 18 months after applicable approvals for R5 and for 24 months after notification by the Planning Coordinator of a new critical facility.
Yes
Agree that the SDT has made revisions that attempted to address the FERC directives. Do not agree with all the proposals by the SDT as indicated by the comments regarding questions 1 through 8.
No
No other comments.
No
Do not agree with all the proposals by the SDT as indicated by the comments regarding questions 1 through 8.
No
No
No
Group
Transmission Access Policy Study Group
William Gallagher
No
The modifications to the Applicability Section meet the FERC directive but have the unacceptable unintended consequence of increasing the burden on DPs with no reliability benefit. Specifically, the modifications make all DPs potentially subject to PRC-023, thus requiring all DPs to incur costs to determine whether the standard is applicable to them. Because PRC-023 should never be applicable to a DP in its capacity as a DP (as opposed to a TO that also happens to be registered as a DP), as explained in TAPS' response to question 6 below, the SDT should simply remove DPs from the Applicability section to prevent the significant potential for confusion and unnecessary costs.
No
The proposed method of identifying facilities to which the standard will apply may be reasonable, though we cannot comment definitively until a draft of Attachment B is available. The standard should not be applicable to DPs, however. TAPS has been unable to find or think of an example in which a DP would have a load-responsive transmission phase protection system, aside from a DP that is also a TO and has such a phase protection system because of its TO function. There is thus no reason to include DPs as potentially applicable entities. If the SDT retains DPs on the list of potentially applicable entities, it should at minimum clarify Requirement R5.3 to state that the Planning Coordinator will provide the list of facilities subject to the standard to all of the TOs, GOs and DPs registered in its footprint, not just to the entities who have facilities on the list. It is important that DPs who do not have facilities on the list have documentation from the Planning Coordinator demonstrating that fact.
Individual
Dan Rochester
Independent Electricity System Operator
Yes
We agree with the Applicability Section and the modification to R5. Note that there is a discrepancy between the entities listed in the Applicability Section and those checked off in the SAR. The latter indicates that the SAR is also applicable to the RC, which we do not believe is required.
No
We agree with the inclusion of Section 2 of Attachment A in the Requirement Section but the proposed modification may not fully meet the directive that the additional requirement is assigned a VRF and VSL. This may require the creation of a separate main requirement rather than simply including the condition as a part of a requirement.
No
The proposed revision goes beyond what's asked for in the directive as it requires the responsible entities to provide the list to entities other than the TOP. The directive asks for providing the list to the TOP only.
No
The objective of R4 as written is unclear. We speculate that by requiring the TOs, GOs and DPs to provide the list (associated with R1. Section 12) to the REs. the ERO will collect the relevant information from all REs to facilitate

provision of such information to owners, users and operators of the BES upon request. If this is the intent, we suggest to replace "REs" with "ERO" to make it a more direct and efficient way to provide the information needed to support the request for information process. The requirement as written does not conform with the results-based concept in that it does not clearly specify a reliability directive. Hence alternatively, we suggest removal of this requirement altogether since the directive asks the ERO to document, subject to audit by the Commission, and to make available for review to users, owners and operators of the Bulk-Power System, by request, a list of those facilities. This can be dealt with outside of the standard process, for example, through RoP 1600.

No

We are unable to assess its acceptability and effectiveness until Attachment B is developed.

Yes

No

We are unable to comment on this in the absence of a proposed implementation plan.

Yes

As indicated in our comment submitted under Q1, there is a discrepancy between the entities listed in the Applicability Section and those checked off in the SAR. The latter indicates that the SAR is also applicable to the RC, which we do not believe is required.

Yes

We general agree with the proposed action but there are detailed changes that we have comments on, which are noted in our comments under Q1 to Q8

No

No

Individual

Bill Miller

ComEd

Yes

Yes

Yes

Yes

Yes

Yes

No

1) Certain relay elements may be thought to be "supervising relay elements", when their function is specific and more limited. A very common example would be a phase overcurrent relay that is required to actuate along with a phase distance relay to cause a trip. In many applications, the phase overcurrent relays function is only to assure that the phase distance relay will not cause a trip when a line is taken out of service and no potential restraint is applied to the phase distance relay. Thus, loadability of the phase overcurrent relay is not a concern. Raising the level of the overcurrent element may negatively impact the fault detecting ability of the two relays. This is perhaps a limited function supervising relay element. It is complementary to the phase distance relay which provides the necessary loadability. 2) Although we don't employ out of step tripping, it would seem that the argument for the overcurrent element of an out of step tripping scheme would be the same as for the phase distance element. 3) Are there supervisory elements for switch onto fault schemes that could limit loadability? 4) In our experience, relays that supervise overcurrent relays are typically specifically designed to provide loadability in order to allow the overcurrent relay to provide greater sensitivity without worrying about its loadability. Thus this requirement would limit the use of such a scheme. 5) FERC's main example seems to refer to an old style of current differential relaying scheme that is likely not very widely applied. Most modern current differential schemes use digital communications and will not trip on loss of communications regardless of the settings of any elements that may be considered to be supervisory relay elements. The drafting team should consider modifying 1.6 of Attachment A to clarify and more specifically address the FERC concern. Three suggestions are as follows: 1) 1.6. Protective functions that supervise operation of other protective functions in 1.5. This is required for communications aided protection schemes in 1.5 only when those schemes require communication channel integrity to maintain scheme loadability. 2) 1.6. Protective functions that supervise operation of other protective functions in 1.2 through 1.5. This is required for communications aided protection schemes in 1.5 only when those schemes require communication channel integrity to maintain scheme loadability. 3) 1.6. Protective functions that supervise operation of other protective functions in 1.2 through 1.5.

Yes



Yes
No
No, other than the comments provided for question 7.
Yes
Yes, given that we assume that NERC must address all the FERC directives whether or not NERC or the industry agrees with them.
No
No
Individual
Kasia Mihalchuk
Manitoba Hydro
Yes
Yes
Yes
Yes
Yes
Yes
No
Item 1.6 in Attachment A is not necessary. If the protection functions in 1.1 through 1.5 already meet all the loadability requirements, the facility would not trip under heavy load condition by the supervising protection element alone. The directive in paragraph 264 of Order 733 seems to deal with the supervising protection element on the current differential scheme only. It is still arguable whether it is better to allow tripping of the line or restrain from tripping during loss communication and heavy loading condition.
No
Even though this version of the standard does seem to have addressed Paragraph 284 of Order 733, we still do not agree with the uniform effective date without taking into consideration how many critical circuits or equipment could be added for an individual utility.
Yes
Yes
The effective date can be dependent upon how many critical circuits or equipment are identified for each individual company.
Yes
No
No
Group
Arizona Public Service Company
Jana Van Ness, Director Regulatory Compliance
No
Agree with the content. However, there is no justification for VRF to be High for the circuits lower than 200 kV.
Yes
Yes
Yes
No
FERC Order required the list to be made available for review to users, owners and operators of the Bulk-Power System

upon request. Requirement 4 does not include the "request" requirement, implying that the Registered Entity must provide the list without a request. Further, the requirement does not specify what the Regional Entity will do with the list once it is provided.

Yes

Yes

Yes

Yes

No

No

Individual

Brian Evans-Mongeon

Utility Services

No

The modifications to the Applicability Section meet the FERC directive but have the unacceptable unintended consequence of increasing the burden on DPs with no reliability benefit. Specifically, the modifications make all DPs potentially subject to PRC-023, thus requiring all DPs to incur costs to determine whether the standard is applicable to them. Because PRC-023 should never be applicable to a DP in its capacity as a DP (as opposed to a TO that also happens to be registered as a DP), as explained in our response to question 6 below, the SDT should simply remove DPs from the Applicability section to prevent the significant potential for confusion and unnecessary costs.

No

The proposed method of identifying facilities to which the standard will apply may be reasonable, though we cannot comment definitively until a draft of Attachment B is available. The standard should not be applicable to DPs, however. We have been unable to find or think of an example in which a DP would have a load-responsive transmission phase protection system, aside from a DP that is also a TO and has such a phase protection system because of its TO function. There is thus no reason to include DPs as potentially applicable entities. If the SDT retains DPs on the list of potentially applicable entities, it should at minimum clarify Requirement R5.3 to state that the Planning Coordinator will provide the list of facilities subject to the standard to all of the TOs, GOs and DPs registered in its footprint, not just to the entities who have facilities on the list. It is important that DPs who do not have facilities on the list have documentation from the Planning Coordinator demonstrating that fact.

Group

Pepco Holdings, Inc - Affiliates

Richard Kafka

Yes

While philosophically we do not agree that this standard should apply to facilities below 100kV (i.e. facilities that are not defined as BES facilities) we believe that as long as a sound engineering methodology is developed and applied uniformly to identify those facilities critical to the reliability of the BES, then the revised wording is acceptable. Our response, however, is qualified based on being granted an opportunity to comment and vote on the methodology once it is developed.

No

The revised wording in paragraph R1 regarding out-of-step blocking schemes is confusing. We suggest rewording the paragraph by splitting the sentence as follows: ...while maintaining reliable protection of the BES for all fault conditions. Use of out-of-step blocking schemes shall be evaluated to ensure that they do not block tripping for faults during the loading conditions defined within these requirements.

No

It would appear that this requirement has already been addressed in the R1 introductory paragraph by the phrase "...while maintaining reliable protection of the BES for all fault conditions." How could one "maintain reliable protection of the BES" if relays are set with operating times that result in equipment being exposed to fault levels and durations that exceed their capability. This introductory requirement to provide reliable fault protection applies to all sub requirements not just to section 10 (old R1.10). As such, the added language in section 10 seems redundant and superfluous. Secondly, if the proposed language were to remain in section 10, why is the term "limiting piece of equipment" used and not just "transformer"? It appears the major concerns related to the comments contained in Order 733 were around exceeding transformer fault level/duration limitations. If that is the concern, why not just use the phrase "do not expose the transformer to fault levels and durations that exceeds its capability"

No

To avoid confusion, the wording of R3 should be revised as follows: "Each Transmission Owner, Generator Owner, and Distribution Provider that chooses to utilize Requirement R1 Setting 2 as the basis for verifying transmission line relay loadability shall provide...." The problem with the SDT's proposed wording of R3 is that suppose a TO chose to utilize R1 Setting 1 criteria (> 150% of 4 hr rating) as their basis for verifying loadability, but the actual relay setting also satisfied criteria R1 Setting 2 (> 115% of 15 min rating) the entity may interpret that they are still obligated to forward the list since the relay settings also satisfied R1 Setting 2 criteria

Yes

Yes

While philosophically we do not agree that this standard should apply to facilities below 100kV (i.e. facilities that are not defined as BES facilities) we believe that as long as a sound engineering methodology is developed and applied uniformly to identify those facilities critical to the reliability of the BES, then the revised wording is acceptable. Our response, however, is qualified based on being granted an opportunity to comment and vote on the methodology contained in Attachment B once it is developed.

No

We do not agree with the proposed wording of Section 1.6 of Attachment A which makes the standard apply to "Protective functions that supervise operation of other protective functions in 1.1 through 1.5". The standard should apply to "protective systems" not individual components of protective systems. Compliance should be based on the ability of the "protective system" as a whole to meet the performance criteria established by the standard. Delving into the details of individual scheme designs and supervising element operation goes well beyond the purpose and scope of this standard. In paragraph 251 of Order 733 the Commission "expressed concern that section 3.1 could be interpreted to exclude certain protection systems that use communications to compare current quantities and directions at both ends of a transmission line, such as pilot wire protection or current differential protection systems supervised by fault detector relays" and requested comment on "whether it should direct the ERO to modify section 3.1 to clarify that it does not exclude from the requirements of PRC-023-1 pilot wire protection or current differential protection systems supervised by fault detector relays." The Commission reiterated again in paragraphs 266, 268, and 270 their concern with not including supervising elements associated with "current differential schemes" to prevent them for operating on loss of communications. That being said, the proposed revision to Attachment A to include supervising elements for all protective functions in 1.1 through 1.5 goes well beyond addressing the Commission's concern. We believe the Commission's concern could be addressed by simply modifying Attachment A by deleting proposed section 1.6 and adding a new section 1.5.5 "Line current differential schemes, including supervising overcurrent elements". The SDT's current proposed wording for Section 1.6 would require the overcurrent element in a switch-on-to-fault scheme to be subject to the loadability criteria. However, the NERC SPCTF in their June 7, 2006 technical paper "Switch-on-to-Fault Schemes in the Context of Line Relay Loadability" indicated there is no suggested loadability criterion if the voltage arming threshold is set low enough. Similarly, fault detectors which supervise distance elements would be subject to the loadability standard. However, there are no criteria established on how to set these elements, particularly on weak source systems, or zone 3 applications, where in order to reliably detect faults at the end of the zone of protection may require setting the supervising fault detector below 150% of line rating. The NERC SPCTF in their June 7, 2006 technical paper "Methods to Increase Line Relay Loadability" provided recommendations to increase loadability of distance elements through various techniques, such as the use of load encroachment elements or blinders, but does not specifically address setting of supervising elements. In fact, at present, there is no reliability standard requiring the use of supervising elements, and some newer microprocessor relays do not even employ supervising fault detectors on their distance elements. FERC in their Order 733 stated "As with our other directives in this Final Rule, we do not prescribe this specific change as an exclusive solution to our reliability concerns regarding the exclusion of supervising relay elements. As we have stated, the ERO can propose an alternative solution that it believes is an equally effective and efficient approach to addressing the Commission's reliability concerns." In summary, we believe that addressing the Commission's concern regarding supervising elements on current differential schemes, as described in our second paragraph above, would satisfy the intent of Order 733, while not imposing unnecessary additional restrictions on what has proven historically to be extremely reliable protection practices.

No

We agree with the removal of the footnote regarding temporary exceptions. However, there appears to be a contradiction between the effective dates for sub 200kV facilities noted in section 5.1.2 (39 months following regulatory approvals) and 5.1.3 (24 months after being notified by its Planning coordinator). If the planning coordinator takes the full 18 months to determine the R5 list (per effective date section 5.2) and the TO has 24 months after that to comply, that would be 42 months following regulatory approval, which is in conflict with the 39 month requirement in 5.1.2. Since the list of sub 200kV facilities may change from year to year, it would seem prudent to make the effective date for those facilities always tied to a defined interval following being notified by the Planning Coordinator and eliminate the 39 month requirement for sub 200kV facilities from 5.1.2. Also, since the Attachment B methodology has not yet been determined, it is unclear how many sub 200kV facilities may fall under these requirements. As such, one cannot yet determine if the proposed 24 months would be sufficient. We propose at least a 36 month interval until the methodology is finalized and the magnitude of the scope better defined. In addition, if supervising elements are included in the standard in some form, an

implementation schedule (i.e. appropriate effective dates) need to be developed based on this significant increase in scope and number of facilities to be reviewed.
Yes
While the scope of the proposed standards action addresses the directive(s) outlined in FERC Order 733 we believe that there are two significant issues that need to be much more thoroughly investigated before being included. Those areas are the inclusion of supervising elements in the existing relay loadability standard and the development of any new standard that would "require the use of protective relay systems that can differentiate between faults and stable power swings and when necessary phase out protective relay systems that cannot meet this requirement."
Yes
Regarding the response of protective relay systems to stable power swings, Draft 5 of TPL-001-2 Requirement R4 (stability assessment) section 4.3.1 requires a contingency analysis be performed which includes "tripping of transmission lines and transformers where transient swings cause protection system operation based on generic or actual relay models." Therefore the impact of power swings on relay operation is already addressed in TPL-001. If the tripping of a line is identified during this study phase the impact of the line trip is assessed to ensure the system meets the performance criteria identified in Table 1. If not, mitigating measures would be required, such as modifying that protection scheme to prevent its operation during a stable power swing. However, this would be done on a case by case basis when identified. This seems a much more prudent approach than to require "all protection systems be modified to prevent operation during stable power swings." That would be similar to requiring the re-conductoring all lines so that they could never experience an overload. Also, Appendix F of the "PJM Relay Subcommittee Protective Relaying Philosophy and Design Standards" employs a methodology to address relay response during power swings by calculating a transient load limit for the relay instead of just the steady state limit identified in PRC-023. The relay loadability is evaluated at the maximum projection along the +R axis (the most susceptible point for swings to enter) rather than at a 30 degree load angle. Various multiplying factors are used to account for the relay operating time delay. This methodology of calculating relay transient loadability limits, which was developed by the PJM Relay Subcommittee over 30 years ago, has worked extremely well in eliminating relay operations during stable power swings. In summary, there are other methods to evaluate and improve the performance of protection systems during power swings short of hardware replacements. All options should be evaluated.
No
We do not agree with the scope of the proposed standards action for numerous reasons. The documented responses to the original FERC NOPR on PRC-023 from numerous sources, including NERC and EEI, together make a rather convincing technical argument against many of these proposed actions. We support these technical arguments, which for the sake of brevity will not be repeated here. In addition, we have provided comments and objections on specific portions of the proposed standards action in our responses to questions 1 through 10 above.
No
No
Group
American Transmission Company
Andrew Z. Pusztai
Yes
However, this affirmative response is conditional depending on whether the criteria that will be established within Attachment B (see R5.1) are reasonable and apply to properly qualified facilities below 200 kV.
Yes
Yes
The word change meets the strict interpretation of the directive, but it is not necessarily improving the reliability of the system. Faults are cleared in cycles and transformer damage curves do not start until at least one second.
Yes
Yes
While achievable, this will not come without effort and does not necessarily improve the reliability of the BES commensurate with the compliance burden.
No
As noted in Q1 above, an affirmative response would be conditional and depend on whether the criteria that will be established within Attachment B (see R5.1) are reasonable and apply to properly qualified facilities below 200 kV. In addition, the R5 requirement should include wording that limits the scope of the transmission facilities (line and transformer circuits) to be evaluated to only those transmission facilities that can be tripped by the relay settings subject to requirement R1. Requirement R5 should also qualify that only the transmission facilities that are "known" to be associated with the relay settings subject to requirement R1 need to be evaluated. If the SDT wants to better assure that the Planning Coordinator knows about all of the pertinent transmission facilities, then they should add a requirement that obligates Transmission Owners, Generator Owners, and Distribution Providers to provide the Planning Coordinator with a list of the transmission facilities that are associated with the relay setting subject to requirement R1.
No
In Order 733, the Commission cites in footnote 186 (p. 161) the definitions of dependability and security, two components of reliability for protective relays. The Commission did not recognize that the two tend to be mutually exclusive. Raising dependability (making sure breakers trip during a fault) can sacrifice some degree of security (tripping more than is needed). Historically, protection engineers have been biased toward dependability to ensure the safety of people and

equipment. The exclusions allow that to happen. These are contingency scenarios where protective schemes are compromised. For a second contingency, the dependability is at risk if fast tripping is not employed. By removing the exclusion, reliability could be negatively jeopardized. For example, an operational decision to open breakers will be needed for loss of potential. The corollary would be leaving the element in service with fast tripping enabled for a fault until the loss of potential condition can be diagnosed and corrected

Yes

Yes

It addresses the directives per the letter of the order; however, it is not necessarily improving reliability.

Yes

On the topic of 'adding in' - listing and evaluating the transmission facilities below 200 kV, we propose the inclusion of qualifications that prevent the consideration and evaluation of irrelevant facilities (e.g. facilities that are not tripped by the applicable relay settings).

No

We agree that the topics of generator relay loadability and power swing protective relaying should be referred to in other separate standards. While we acknowledge that it is in everyone's best interest to respond to the FERC directives, there are numerous technical flaws that need to be resolved in their request. Forming a team and spending considerable resources will not gain industry acceptance to these directives.

No

No

Individual

Tribhuwan Choubey

Southern California Edison

No

Applicability clause 4.12 and 4.14 - Formulating a consistent methodology test to determine for a sub 200KV facility by the Planning Coordinator is quite an uphill task keeping in view the different circuit configuration different utilities may have. It is best left alone to each utility to determine the facilities which can be a candidate for inclusion as a bulk power system. The current risk based assessment criteria to determine bulk power facility should be continued.

No

Requirement R1.7, R1.8, R1.13 do not provide a clear guideline on generators connected to the load center on Radial basis, where load current into the generators ( forward direction current seen by the relay) is just an auxiliary load and insignificant compared to the transmission line rating.

No

The relay if set according to Requirement R1.2 are based upon 15 minute highest seasonal facility loading duration. This gives sufficient time for the operators to take manual corrective action, if the deem so. There is no need for the Registered entity to provide a list, as it would not be efficient and cost effective.

Group

PSEG Companies

Kenneth D. Brown

No

In attachment A was added a new requirement, item 1.6. We not agree with this. Sometimes these elements have to be set lower than the criteria. As long as the protection system as a whole does not trip the line, then that should meet the criteria. Individual elements that supervise tripping element should NOT be part of the standard.

No
No
Individual
Dale Fredrickson
Wisconsin Electric
No comment
No comment
No comment
No comment
No comment
No comment
No comment
No
We strongly disagree with this change. Applying the loadability requirement to supervisory functions in protection system will have an extremely negative effect on BES reliability. With this change, protection systems will be less dependable, resulting in increased probability of a failure to detect a system fault. This change should not be implemented.
No comment
No comment
No comment
No comment
No
No
Group
PacifiCorp
Sandra Shaffer
Yes
Yes
Yes
Yes
Yes
No
Paragraph No. 264 directs a revision to Section 1 of Attachment A in order to include supervising relay elements. This change as currently written requires further clarification to meet this directive. For example, a Distance element is commonly supervised by a phase overcurrent element (Fault detector). If this change suggests that the overcurrent element has to be set above maximum load, then PacifiCorp disagrees with the modification. The fault detector will not trip the line by itself; it operates to qualify the distance element assertion. It is our standard practice to set this element above load where possible, but without restricting the reach of the distance element. This means that if the fault current at the maximum reach of the distance element is below load, setting the fault detector above load will restrict the reach of the distance element- this would compromise the protection scheme. In microprocessor relays where Load encroachment is used this is even more critical. The Load encroachment function will prevent the distance element from operating in the load region and a fault detector setting that is sensitive enough can be used safely without the need to set it above load current to enhance the distance element reach.
Yes
No
No
It is very difficult to comment on test parameters that have not been determined.

No
No
Group
Southern Company
Andy Tillery
Yes
Yes
Yes
Yes
Yes
Yes
Yes
No
The language that has been added to PRC-023 related to the inclusion of protection elements (fault detectors) supervising protection functions that are subject to the PRC-023-2 requirements is not appropriate and will likely decrease the reliability of the BES for the following reasons: - The tripping logic utilizing these elements is an AND function, it takes distance element AND the fault detector (FD) to trip. Since all distance elements meet the loadability criteria, it is not necessary to also ensure FD meet these requirements. - Setting FD above nominal load point would unnecessarily reduce sensitivity of distance element and in many cases eliminate the distance element's ability to protect the very system element it is designed and intended to protect - It would require very expensive communications based relay schemes to replicate this lost protection if it is even possible to do so; a long radial line is one instance where it would not be possible - Eliminating the FD would actually reduce Security and Dependability in electromechanical schemes - There is a whole generation of microprocessor based relays that it is not possible to eliminate the FD; to effectively take it out of service, one would have to set it to the most sensitive setting which would violate the loadability criteria - Relays at terminals with high SIR, a weak source system, and line with large conductors where the far end fault current may be smaller than maximum line current (similar to Exception 6 of the Relay Loadability Exceptions: Determination and Applications of Practical Relaying Loadability Ratings, Version 1.1 published November 2004 by the System Protection and Control Task Force of NERC) - Faults with low power factor could present a similar magnitude of line current as normal high power factor load currents
Yes
Yes
No
Yes
No
No
Group
Bonneville Power Administration
Denise Koehn
Yes
No
The modified Requirement R1 requires that one of the 13 criteria be used to prevent out-of-step blocking schemes from blocking tripping for fault conditions. The problem is that the 13 criteria are only related to loading conditions, and it is not clear how they would be applied to prevent out-of-step blocking schemes from blocking a trip during a fault, or if it is even possible to use these criteria for this purpose. The modified Requirement R1 requires actions that are ambiguous and we cannot support it as written.
No
In some cases, Section 10 of Requirement R1 would be impossible to meet. For example, a 150/200/250 MVA, OA/FOA1/FOA2 transformer is required by Section 10 to have its protection set so that it doesn't operate at or below 150% of the maximum transformer rating of 250MVA. or $1.5 \times 250 = 375 \text{MVA}$ . The modified Section 10 would also require

<p>that the protection not expose the transformer to a fault level and duration that exceeds its capability. According to IEEE C37.91, a through-fault of two times the transformers base rating, <math>2 \times 150 = 300\text{MVA}</math>, will be damaging to the transformer. For this particular transformer, which is not unusual, Requirement R1, Section 10, requires the protection to operate for through faults of 300MVA or greater, but not operate for loads of 375MVA or less. It is impossible to simultaneously meet both of these conditions, so Section 10 is unacceptable. One possible way to correct the problem is to change the requirement so that the protection does not operate below 200% of the transformer base rating. This would allow the protection to meet IEEE C37.91 for through-faults and still allow overloading of the transformer.</p>
<p>This change adds an additional burden to the applicable entities, but serves no purpose other than to satisfy FERC's misinterpretation of what a fifteen-minute facility rating is.</p>
<p>No</p>
<p>Requirement R5 is okay, but Part 5.1 adds an additional and useless extra burden to the applicable entities. The process that the Planning Coordinator is required by this part to have would almost certainly be to simply apply the criteria in Attachment B to lines and transformers operated below 200kV to determine if they are critical to the BES. Requiring documentation for such a trivial process results in increased paper work, additional preparation for an audit, and is a waste of everyone's time. We suggest deleting Part 5.1.</p>
<p>No</p>
<p>Here we have a situation where the standard is being compromised to satisfy FERC's misunderstanding of what a supervising relay is. In Paragraph 266, FERC gives an example of how a line differential relay works in an attempt to demonstrate why supervisory elements must not operate for load, but instead they clearly demonstrate their misunderstanding of the details of differential relay operation and what a supervisory relay is. Modern differential relays will disable the differential function upon loss of communications. If an overcurrent element is present, it would be used for backup protection, not as a supervisory element. If an overcurrent element were used to supervise a differential element, the sensitivity of the differential relay would be lost and the result would be a simple overcurrent relay. FERC's misunderstanding has resulted in the improper addition of supervisory relays in Attachment A, Section 1. Sometimes supervisory relays must be set below maximum loading to obtain the purpose they were intended for. For example, it is often necessary to set overcurrent supervision of distance relays below the maximum load current of the line so that they will operate for remote faults. This modification to Attachment A would prohibit that action and make it impossible to set the supervisory relays to comply with the standard and still provide adequate protection. The modification to Attachment A is unacceptable.</p>
<p>5.1.2 and 5.1.3 both apply to the same systems and should be combined into one sub-requirement. Also, since the date of the applicable regulatory approval is now established, please consider replacing the cryptic phrase "at the beginning of the first calendar quarter 39 months following applicable regulatory approval" with an actual date.</p>
<p>Yes</p>
<p>No</p>
<p>Yes</p>
<p>No</p>
<p>No</p>
<p>Individual</p>
<p>Kathleen Goodman</p>
<p>ISO New England Inc.</p>
<p>No</p>
<p>We believe this directive needs to be addressed by a full standards drafting team to ensure the precise language is crafted to adequately address the directive. Furthermore, we believe only the full standards drafting team could identify equally effective alternatives to the Commission's directives as they have made clear they allow in this Order and many others. Some immediate concerns with the proposal include: 1) Our understanding is that the application of NERC standards is limited to the BES. Thus, facilities below 100 kV must be included in the Regional Entity definition of BES to be eligible. The requirements should reflect this. The way the proposed standard reads, one might conclude the PC must test every facility below 100 kV. This surely can't be the intent. 2) Furthermore, the directive appears to require some action on the Regional Entities. From paragraph 60, "We also direct that additions to the Regional Entities' critical facility list be tested for their applicability to PRC-023-1 and made subject to the Reliability Standard as appropriate." It is not clear how this directive is reflected in the standard to ensure that this work is completed prior to the PC's performing their assessment for below 200 kV facilities. The bottom line is that the changes here are significant enough that they would benefit from a group of experts reviewing the directives and proposing the precise language that is needed.</p>
<p>No</p>
<p>Requirement R1, Parts 7, 8 and 9: Requirement R1, Parts 7, 8 and 9, replace the phrase "under any system configuration" with "under any system condition." 7. Set transmission line relays applied at the load center terminal, remote from generation stations, so they do not operate at or below 115% of the maximum current flow from the load to the generation source under any systemcondition. 8. Set transmission line relays applied on the bulk system-end of transmission lines that serve load remote to the system so they do not operate at or below 115% of the maximum current flow from the system to the load under any systemcondition. 9. Set transmission line relays applied on the load-end of transmission lines that serve load remote to the bulk system so they do not operate at or below 115% of the maximum current flow from the [ ] to the under anv system condition. [Brackets added. also see further comment on missina wordina following]</p>



<p>This phrase "under any system configuration" could be construed as being too all-inclusive, as one could postulate multiple events, e.g., simultaneous outages, which however unlikely could permit power flows in a direction for which the system was not originally designed. As with the second comment below, the phrase "under any system condition" was part of Revision 1 and is unchanged by Revision 2, however, the new applicability to below 200 kV creates the new concern. Requirement 1, part 9: As currently written, Requirement 1, part 9 states: 9. Set transmission line relays applied on the load-end of transmission lines that serve load remote to the bulk system so they do not operate at or below 115% of the maximum current flow from the [____] to the under any system configuration. [Brackets added] Some words are missing. The brackets have been added above to show one place where at least some of the needed wording may be missing. A rewrite is necessary in order for this sentence to make any sense.</p>
Yes
No
<p>We do not understand the need for this directive or requirement. A relay that is set to operate at 115% greater than the 15-minute rating of the facility does not equate to damage occurring on that facility if operated at that point in 15 minutes. Furthermore, it does not mean the relay will operate in 15 minutes nor does it mean the operator has only 15 minutes to take action. In fact, the operator may have less time depending on the time delay set on the relay. It is no different than any other relay. Usually, the facility will be operated with some buffer so that there is no chance that an entity could trip the facility due to loading above the relay limit. In fact, the transmission operator should be aware of any relay that might be the limiting facility so they can operate the facility with some margin of error to ensure they don't inadvertently cause a relay operation due to loading.</p>
Yes
Yes
Yes
No
<p>While we agree removing the footnote is straight forward and addresses one Commission directive. In particular, we believe that only a full drafting team could adequately assess if any additional time will be needed to comply with the standard for sub-100 kV facilities particularly when we consider there are some outstanding issues a regional entities critical facilities list identified in Question 1. Also, we are unable to assess if the two directives are fully addressed absent a proposed implementation plan.</p>
Yes
No
<p>We are not prepared at this time to offer equally efficient and effective alternatives. Rather, we believe this is the purpose for convening a full drafting team and that the drafting team should propose their alternatives.</p>
No
<p>We largely believe the scope will allow the drafting team to address the directives. However, we request that the scope be modified to make clear that the drafting may use equally effective alternatives to address the Commission's directives per the Commission in this order and other orders such as Order 693. The scope should address apparent conflicts in the timing of requirements posed by the standard. It is our understanding that, based on the final date afforded NERC to develop the criteria for the determination of sub-200 kV facilities, a newly proposed implementation plan will be offered to allow the Planning Coordinators an appropriate time frame to apply the criteria to determine the "critical" facilities below 200 kV. The implementation plan should cause the effective date for circuits described in 4.1.2 and 4.1.4 to be changed from "39 months following applicable regulatory approvals" to a date linked to the Planning Coordinators schedule to provide a list to its TOs, GOs and DPs.</p>
No
<p>We are not aware of any regional variances per se. However, each regional entity has its own definition for BES and this needs to be considered when addressing sub-100 kV facilities.</p>
No
Individual
Robert Ganley
Long Island Power Authority
No
<p>There appears to be a disconnect between FERC's "sub 100 kV" and proposed "below 200 kV" revision in the Applicability Section. LIPA seeks clarification on this. Also, by whom and by which method will the criticality of the substations be ascertained?</p>
No
<p>Requirement R1, Parts 7, 8 and 9, replace the phrase "under any system configuration" with "under any system condition:" This phrase "under any system configuration" could be construed as being too all-inclusive, as one could postulate multiple events, e.g., simultaneous outages, which however unlikely could permit power flows in a direction for which the system was not originally designed. Requirement 1, part 9: As currently written, Requirement 1, part 9 states: 9. Set transmission line relays applied on the load-end of transmission lines that serve load remote to the bulk system so they do not operate at or below 115% of the maximum current flow from the [____] to the under any system configuration. [Brackets</p>

added] Some words are missing. The brackets have been added above to show one place where at least some of the needed wording may be missing. A rewrite is necessary in order for this sentence to make any sense.
Yes
Yes
No
FERC order 733 p224 requires that the list of facilities that have protective relays set pursuant to R1.12 of anticipated overload be made available to users, owners, and operators of the BPS. However, the proposed revision to R4 requires the list to be made available to Regional Entity only. Please clarify. Also, FERC order uses the term "by request" which is missing from the proposed revision.
No
LIPA understands the drafting team's rationale, however, believes that the proposed method in Attachment B should be developed before providing comments.
No
LIPA believes that the new wording in 1.6 Attachment A is unnecessary since the existing wording already complies with the FERC order p.264. Supervisory functions are already part of the protective functions 1.1 through 1.5. Also, this new wording will be subject to varied interpretation and create more confusion.
No
Yes
Yes
Involving industry working groups such as IEEE, EPRI, etc who have proven technical experts will also help in effectively achieving reliability.
Yes
LIPA agrees with the scope in general. Please consider our comments above for answers to specific issues.
Yes
NPCC BPS definition based on A10 criteria is a regional variance.
No
Individual
Kirit Shah
Ameren
No
Attachment B as mentioned in R5 is not available for review.
Yes
No
The language is not clear. It appears that the transmission line relays are being used as the thermal overload protection for the transformer.
Yes
No
See our response to Question 1
No
In attachment A – 1.6 is not a tripping function – it's a supervisory function – it in itself does not trip which is the description of '1' therefore needs to be elsewhere if kept.
Yes
No
No
Individual
Thad Ness
American Electric Power

No
AEP understands the intent of the FERC Order (Paragraph 60) to address the sub-100 KV facilities only if they are associated with critical facilities above 100 KV. The applicability and the associated requirements should be reworded to ensure that the Planning Coordinator does not have to identify critical facilities below 100 KV.
Yes
Yes
Yes
Yes
No
Please refer to our comment under question number 1. AEP reserves the right to provide additional comments once Attachment B has been drafted and supplied for industry review.
No
AEP requests some clarifying information regarding what is envisioned for 1.6 of Attachment A.
No
It is unclear how much time a TO, GO, or DP would have to implement the changes based on the results of the analysis by the Planning Coordinator. In addition, the Effective Date section is a one-time event upon regulatory approval. What are the on-going implementation expectations? There should be some allowed lead beyond initial implementation after facilities are identified by the Planning Coordinator.
No
Refer to our comment under question 1.
No
Not at this time, but AEP would like to consider all viable options throughout the standard development process.
Yes
No
No
Individual
Michael Moltane
ITC Holdings
Yes
No
The proposed wording seems out of place in this requirement and is not clear as how it is being applied to subrequirements 1 - 13
No
R1 -10 is all about loadability of the relays protecting the transformer. If the requirements of R1-10 cannot be met without exceeding the transformer damage curve, then we go to R1-11. We do not feel that there should be anything to do with fault duty.
Yes
Yes
Yes
No
It appears from the new 1.6 (Attachment A) that fault detectors must meet loadability requirements. These do not trip and must not be included in PRC023. We will not be able to adequately protect longer lines in weak areas with this requirement in place.
No
The new effective dates for 5.1.2 will for the most part be ok. Some of these below 200 kV lines will have to be reconstructed to be able to have adequate protection and meet the required loadability. It will be difficult to do this in 39 months. We suggest a mitigation program be required for those lines that will be difficult to meet the 39 month deadline.
Yes
No

No
Several parts of the standard go too far (Appendix A R1.10) and will require us to document faults and clearing times to prove the fault duty of transformer connections. Also the requirements to deal with out of step blocking relays should go in phase 3 and not in this standard.
: Utilities with long lines and in weak areas will have difficulty protecting their lines and meeting the required loadability. Regions where there are very rural systems will want to write standards that allow adequate protection for their systems.
No
Group
FirstEnergy
Doug Hohlbaugh
Yes
Yes
No
Although it is true that the FERC directive specifically states "limiting piece of equipment" their reasons and justifications all involve transformers. We propose replacing "limiting piece of equipment" with "transformer" would meet the FERC's reliability concern as well as provide clarity to applicable entities. We believe this is an equally effective means of meeting the directive.
No
We suggest removing the Regional Entity from the list of entities receiving this information since they do not have a reliability-related need for it.
Yes
Yes
Although we agree that R5 is the appropriate requirement to reference the criteria to be used, it is still to be determined if we agree with the criteria since it is still being developed.
No
FirstEnergy supports applying PRC-023 to certain supervising relays, such as overcurrent relays that are enabled only when another (usually communications based) scheme is out of service, or overcurrent relays that are ANDed with current differential elements that can trip by themselves if the communications path used by the current differential scheme is compromised. However, it is not clear that a 150% factor is the correct one to use in this case. Our understanding is that 150% is a combination of an error factor (widely utilized by industry) of 15% plus a 35% margin to approximate a 15 minute interval rating to give operators time to react to adverse system conditions. It is unclear that this extra 35% margin is needed for these supervising relays, when the reliability goal is to prevent relays being continuously picked-up. We recommend that the standard utilize a 115% margin (rating duration nearest 4 hours) for these types of supervising relays and that this would be adequate to meet the Commission's stated reliability concerns. However, there are several other types of schemes that utilize supervising relays where applying PRC-023 would be detrimental to the reliability of the bulk power system. One widely used case is the supervision of an impedance relay when there is no communications scheme involved. There are cases where an impedance element/relay which is set per PRC-023, correctly operates for a fault it is intended to see, but that the actual current value will be on the order of the line rating, which will result in the scheme not operating if the supervising relay is set as the commission proposes. The alternative for these types of schemes is to remove the supervision from the scheme, which will result in the scheme operating purely on the impedance element, which is exactly the reliability concern that the Commission is trying to address with this directive. However, many microprocessor relays have inherent overcurrent supervision of impedance elements which cannot be disabled, adding to the complexity of the issue. Since this is a fairly complex theoretical/technical issue, we recommend that the NERC System Protection and Control Subcommittee (SPCS) investigate this issue and produce a white paper or other document describing any unintended consequences of implementing the FERC directive. The work of the SPCS could also consider equally effective alternatives to meeting the Commission's directive.
Yes
No
i. The SAR shows the directive from P. 162 as part of Phase I to be implemented by March 18, 2011. However, this directive should be included in Phase III since it deals with the subject of relay operations due to power swings. ii. The directive from P. 224 is missing from the detailed section of the SAR, but is included in the table in the back of the SAR. iii. As mentioned in our response to Question 7, we do not agree with how the project is proposing to address the P. 264 directive.
No
Regarding the directive of Par. 264, since this is a fairly complex theoretical/technical issue, we recommend that the NERC System Protection and Control Subcommittee (SPCS) investigate this issue and produce a white paper or other document describing any unintended consequences of implementing the FERC directive. The work of the SPCS could also consider equally effective alternatives to meeting the Commission's directive.
Yes
We agree that this standards action is necessary to meet the FERC directives. but have some concerns as we have stated

in previous responses above.
No
No
Group
TSGT System Planning Group
Bill Middaugh
Yes
No
We suggest that the added phrase be removed from R1 and a new requirement created. Suggested wording is "Protection Systems that block for stable swings or out-of-step conditions shall be evaluated to ensure that appropriate tripping will occur for in-section faults that occur during the condition. Some additional delay may be required and is acceptable to ensure that the appropriate tripping occurs."
Yes
No
We think that the data needs to be given only to the Transmission Operators, which is what FERC Order No. 733 requires. We also believe that an initial submittal is sufficient until any responsible entity begins or stops using Requirement 1, Setting 2 for setting a phase protective relay that is used to protect an applicable facility. There is no need for periodic duplicate submittals.
No
FERC Order No. 733 requires the settings be provided upon request and no initial or periodic submittal is required.
No
While we agree that the purpose of Requirement R5 is beneficial, there is much confusion about registration and responsibilities of Planning Coordinators. Though the FERC order proposes that planning coordinators perform the test developed herein, there is also flexibility in how NERC can achieve the same result. We believe that the Regional Entity (or the Reliability Coordinator, as was included in the System Protection and Control Task Force recommendation) should be the responsible functional entity for determining which elements operated at less than 200 kV need to meet Requirement R1. The Region was responsible for determining operationally significant facilities during the "Beyond Zone 3" process.
Yes
As we interpret the changes to Attachment A they are acceptable. However, there appears to be uncertainty about the intent of the drafting team. We interpret the change to 1.6, in conjunction with 2.1, to allow setting impedance relay fault detector supervisory elements at levels below load current levels. This understanding comes from the realization that the fault detector elements by themselves do not "trip with or without time delay, on load current," a requirement described in 1. The fault detector elements can cause tripping on their own, but only for conditions of loss of potential or loss of communications, which are both excluded from the loadability requirements as stated in 2.1. If Tri-State's interpretation of the intent of Attachment A, Sections 1, 1.6, and 2.1 is incorrect, then we do not agree that this is an acceptable and effective method of meeting this directive. There are many protection system locations in our system that require the fault detector supervision elements to be set below load current levels in order for backup impedance relays to operate securely in the event of loss of potential and to operate dependably for remote faults that inherently have low fault current magnitudes.
Yes
No
As stated in our earlier comments, we believe that some proposals exceed the directives. It is also not clear how p 162 was addressed in PRC-023-2 as indicated on SAR-3.
Yes
We included specific proposals in our comments to questions 2, 4, 5, and 6.
Yes
We agree that the scope meets the FERC directive, but some of the proposals in the proposed standard reach beyond the directive.
No
No
Individual
Yes
Yes
Yes

Yes
Yes
Yes
No
Removal of exclusion 3.1 in Att. A, will lead to reduced reliability because an operational decision to open breakers will be needed for loss of potential conditions. The corollary would be leaving the element in service with fast tripping enabled for a fault until the loss of potential condition can be diagnosed and corrected.
Yes
Yes
No
No
Removal of exclusion 3.1 in Att. A, will lead to reduced reliability because an operational decision to open breakers will be needed for loss of potential conditions. The corollary would be leaving the element in service with fast tripping enabled for a fault until the loss of potential condition can be diagnosed and corrected.
No
No
Individual
Laura Zotter, Steve Myers
ERCOT ISO
The entities who receive the list of facilities should be the same from R3 to R4.
The entities who receive the list of facilities should be the same from R3 to R4.
No
ERCOT ISO respectfully asserts that the changes in this standard need more thorough discussion. This standard is incomplete without the Attachment B and the intent of the requirements is not explicitly clear. A standard drafting team (not a SAR SDT) needs to develop Attachment B through discussion of the entire process that will meet Order 733 directives. Attachment B is a critical component needed to assess R5 and provide further feedback. Requirement 5 needs to be reworded for clarity. The standard drafting team assigned to this project needs to work closely with the Reliability Coordination SDT (Project 2006-06), which is tasked with defining critical facilities or identifying criteria for developing a list of critical facilities. ERCOT ISO disagrees with the use of the phrase 'facilities that are critical' in this requirement. A requirement to create a list of critical facilities should not be addressed in this standard.
ERCOT ISO thinks a standard drafting team can evaluate the Order 733 directives, work in conjunction with other Standard Drafting Teams already addressing some aspects of critical facilities, may be able to more succinctly arrive at an equally efficient and effective method of achieving the intent of the directive(s). The coordination between teams is vital to avoid confusion and possible overlap.
Individual
RoLynda Shumpert
South Carolina Electric and Gas
No
This requirement needs to be refined to clearly state the intent. It is unclear if "limiting piece of equipment" is referring to just transformers or other elements. Some of the elements involved in the construction of a transmission line/transformer arrangement such as line conductors, etc. may not have published fault current ratings. It is unclear how to determine the most limiting piece of equipment if published fault current ratings are not available for these devices

No
Item 1.6 of Attachment A needs to be clarified. If the intent is to include protective functions such as fault detectors then this could possibly lead to relay sensitivity problems when switching contingencies create weaker systems than normal and a line is faulted. It is unclear why supervisory functions are considered if the protective functions they supervise will operate in compliance with R1
Individual
Jon Kapitz
Xcel Energy
Yes
Yes
Yes
Yes
Yes
Yes
No
Xcel Energy disagrees with the inclusion of the supervising functions in part 1.6 of Section 1 in Attachment A. Supervising functions in protection schemes provide security for non-power system fault events and are not the principal elements for scheme operation. Only principal elements should be considered in the requirements of the PRC-023 standard. Functions such as overcurrent fault detectors provide security in the event of a failed potential source or blown secondary fusing. Fault detectors must be set below the minimum end-of-zone fault with a single system contingency in effect. It is common industry practice to set these functions at 60-80% of these minimum fault levels and may necessitate a setting that is below the Facility Rating of a circuit. Increasing the setpoint of an overcurrent fault detector above the Facility Rating will limit the coverage of the protection system and may impact the system's ability to protect the electrical network from Faults. An alternative is to limit the Facility Rating as allowed in Requirement R1.12. However limiting this Facility Rating places an arbitrary constraint on the circuit and is not justifiable for a non-principal function. Eliminating the fault detector is not possible in the case of some microprocessor-based relays and if it is possible, reduces the security of the protective scheme.
Yes
Group
IRC Standards Review Committee
Ben Li
No
We believe this directive needs to be addressed by a full standards drafting team to ensure the precise language is crafted to adequately address the directive. Furthermore, we believe only the full standards drafting team could identify equally effective alternatives to the Commission's directives as they have made clear they allow in this Order and many others. Some immediate concerns with the proposal include: 1) It is not clear what a "critical facilities list identified by the Regional Entity" is as specified within the order so addressing the directive is a challenge. This standard is not the appropriate venue for development or consideration of a critical facilities list. There is a supplemental SAR in process for the Reliability Coordination project that is to address that topic. 2) Our understanding is that the application of NERC standards is limited to the BES. Thus, facilities below 100 kV must be included in the Regional Entity definition of BES to be eligible. The requirements should reflect this. The way the proposed standard reads, one might conclude the PC must test every facility below 100 kV. This surely can't be the intent. 3) Furthermore, the directive appears to require some action on the Regional Entities. From paragraph 60. "We also direct that additions to the Regional Entities' critical facility list be tested for their

applicability to PRC-023-1 and made subject to the Reliability Standard as appropriate.” It is not clear how this directive is reflected in the standard to ensure that this work is completed prior to the PC’s performing their assessment for below 200 kV facilities. This standard is not the appropriate venue to determine or revise a critical facilities list, nor is it appropriate for a Regional Entity to establish such a list. The bottom line is that the changes here are significant enough that they would benefit from a group of experts reviewing the directives and proposing the precise language that is needed.

No

We believe this directive needs to be addressed by a standards drafting team to ensure the precise language is crafted to adequately address the directive. Furthermore, we believe only the full standards drafting team could identify equally effective alternatives to the Commission’s directives as they have made clear they allow in this Order and many others.

No

We believe this directive needs to be addressed by a full standards drafting team to ensure the precise language is crafted to adequately address the directive. Furthermore, we believe only the full standards drafting team could identify equally effective alternatives to the Commission’s directives as they have made clear they allow in this Order and many others. Additionally, we question if this directive should be addressed in the FAC standards rather than in PRC-023.

No

We do not understand the need for this directive or requirement. A relay that is set to operate at 115% greater than the 15-minute rating of the facility does not equate to damage occurring on that facility if operated at that point in 15 minutes. Furthermore, it does not mean the relay will operate in 15 minutes nor does it mean the operator has only 15 minutes to take action. In fact, the operator may have less time depending on the time delay set on the relay. It is no different than any other relay. Usually, the facility will be operated with some buffer so that there is no chance that an entity could trip the facility due to loading above the relay limit. In fact, the transmission operator should be aware of any relay that might be the limiting facility so they can operate the facility with some margin of error to ensure they don’t inadvertently cause a relay operation due to loading.

No

The objective of R4 as written is unclear and does not conform with the results-based concept in that it does not clearly specify a reliability directive. We suggest removing this requirement altogether as we do not believe this should be an on-going enforceable requirement. Rather, we think it makes more sense for NERC to use section 1600 of its Rules of Procedure to request the data. We believe that NERC and the Commission will likely determine that they don’t need to continually receive this data after reviewing it the first time. Nothing in the directive indicates this must be accomplished through a standard. If NERC and FERC do identify a continuing need for the data, the standard could be modified at a later date.

No

We disagree with modifying the requirement until the criteria is identified. Modifying the requirement now presumes the criteria will have no impact to the requirement. Contrarily, we believe that the criteria may cause some change to the requirement as well. The criteria in Attachment B along with any necessary modifications to the associated requirement should be developed by a full standards drafting team. Only the full standards drafting team could identify equally effective alternatives to the Commission’s directives as they have made clear they allow in this Order and many others.

No

We believe this directive needs to be addressed by a full standards drafting team to ensure the precise language is crafted to adequately address the directive. Furthermore, we believe only the full standards drafting team could identify equally effective alternatives to the Commission’s directives as they have made clear they allow in this Order and many others.

No

While we agree removing the footnote is straight forward and addresses one Commission directive, we believe the other directives need to be addressed by a full standards drafting team to ensure the precise language is crafted to adequately address the directives. Furthermore, we believe only the full standards drafting team could identify equally effective alternatives to the Commission’s directives as they have made clear they allow in this Order and many others. In particular, we believe that only a full drafting team could adequately assess if any additional time will be needed to comply with the standard for sub-100 kV facilities particularly when we consider there are some outstanding issues including a regional entity’s critical facilities list identified in Question 1. Also, we are unable to assess if the two directives are fully addressed absent a proposed implementation plan.

No

We largely believe the scope will allow the drafting team to address the directives. However, we request that the scope be modified to make clear that the drafting team may use equally effective alternatives to address the Commission’s directives per the Commission in this order and other orders such as Order 693. There is a discrepancy between the entities listed in the Applicability Section and those checked off in the SAR. The latter indicates that the SAR is also applicable to the Reliability Coordinator, which we do not believe is appropriate.

No

We are not prepared at this time to offer equally efficient and effective alternatives. Rather, we believe this is the purpose for convening a full drafting team and that the drafting team should propose their alternatives.

No

We largely believe the scope will allow the drafting team to address the directives. However, we request that the scope be modified to make clear that the drafting team may use equally effective alternatives to address the Commission’s directives per the Commission in this order and other orders such as Order 693.

No

We are not aware of any regional variances per se. However, each regional entity has its own definition for BES and this needs to be considered when addressing sub-100 kV facilities.

No



Group
MRO's NERC Standards Review Subcommittee
Carol Gerou
No
However, this response is conditional depending on whether the criteria that will be established within Attachment B (see R5.1) are reasonable and apply to properly qualified facilities below 200 kV.
Yes
No
The word change meets the strict interpretation of the directive, but it is not necessarily improving the reliability of the system. Faults are cleared in cycles and transformer damage curves do not start until at least one second.
Yes
No
While achievable, this will not come without effort and does not necessarily improve the reliability of the BES commensurate with the compliance burden.
No
As noted in Q1 above, a response would be conditional and depend on whether the criteria that will be established within Attachment B (see R5.1) are reasonable and apply to properly qualified facilities below 200 kV. In addition, the R5 requirement should include wording that limits the scope of the transmission facilities (line and transformer circuits) to be evaluated to only those transmission facilities that can be tripped by the relay settings subject to requirement R1. Requirement R5 should also qualify that only the transmission facilities that are "known" to be associated with the relay settings subject to requirement R1 need to be evaluated. If the SDT wants to better assure that the Planning Coordinator knows about all of the pertinent transmission facilities, then they should add a requirement that obligates Transmission Owners, Generator Owners, and Distribution Providers to provide the Planning Coordinator with a list of the transmission facilities that are associated with the relay setting subject to requirement R1.
No
In Order 733, the Commission cites in footnote 186 (p. 161) the definitions of dependability and security, two components of reliability for protective relays. The Commission did not recognize that the two tend to be mutually exclusive. Raising dependability (making sure breakers trip during a fault) can sacrifice some degree of security (tripping more than is needed). Historically, protection engineers have been biased toward dependability to ensure the safety of people and equipment. The exclusions allow that to happen. These are contingency scenarios where protective schemes are compromised. For a second contingency, the dependability is at risk if fast tripping is not employed. By removing the exclusion, reliability could be negatively jeopardized. For example, an operational decision to open breakers will be needed for loss of potential. The corollary would be leaving the element in service with fast tripping enabled for a fault until the loss of potential condition can be diagnosed and corrected.
Yes
No
It addresses the directives per the letter of the order; however, it is not necessarily improving reliability.
Yes
On the topic of 'adding in' - listing and evaluating the transmission facilities below 200 kV, we propose the inclusion of qualifications that prevent the consideration and evaluation of irrelevant facilities (e.g. facilities that are not tripped by the applicable relay settings).
No
We agree that the topics of generator relay loadability and power swing protective relaying should be referred to in other separate standards. While we acknowledge that it is in everyone's best interest to respond to the FERC directives, there are numerous technical flaws that need to be resolved in their request. Forming a team and spending considerable resources will not gain industry acceptance to these directives.
No
No
Group
Dominion Electric Market Policy
Mike Garton
No
It depends on what Attachment B (R5.1) requires once it is developed. Without knowledge of the final content developed for Attachment B, we do not support this.
Yes
No
The requirement is not clear. For example, how do we determine and verify the limiting piece of equipment under fault conditions? It might be a splice or a jumper. Since the document refers to duration, this seems to apply mainly to

transformer overcurrent relaying which would be for overload protection not fault protection that has no intentional delay.
Yes
Yes
Yes
No
Dominion disagrees with the directive to the ERO to revise section1 to include supervising relays for example, the fault detectors that we have in electromechanical distance schemes. The impedance relays are set to meet Reliability Standard PRC-023-1 while the overcurrent fault detector does not trip the transmission line breaker(s) independently of the impedance relays. Simultaneously meeting full allowance of the line terminal emergency loading limit and providing adequate sensitivity for detecting line faults with this fault detector will simply not be achievable for many of our lines.
Yes
Yes
No
Yes
No
No
Since there is no question that asks if there are other concerns with this draft, I will add one here..... R2 should be modified to read " The Each Transmission Owner, Generator Owner, or and Distribution Provider that uses a circuit capability with the practical limitations described in Requirement R1, Settings1.6, R1.7, R1.8, R1.9, R1.12, or R1.13 shall use the calculated circuit capability as the Facility Rating of the circuit and shall forward this information to the Planning Coordinator, Transmission Operator, and Reliability Coordinator. The burden for acknowledging agreement or specifying reasons for disagreement should reside with the Planning Coordinator, Transmission Operator, and Reliability Coordinator. Suggest SDT develop additional requirements similar to those in FAC-008 @ R2 and R3.
Individual
Greg Rowland
Duke Energy
Yes
Yes
No
R1.10 has added the requirement that protection settings can't expose transformers to fault levels and durations that exceeds its capability, while at the same time not operate at or below 115% of highest emergency rating. We would argue that an overcurrent relay cannot be set to satisfy both requirements. A transformer's through-fault protection curve (C37.91) begins at 200% of the transformers self-cooled rating. The highest emergency rating is commonly 150% (or higher) of the transformer's highest (cooled) rating. Overcurrent relays could not be set to coordinate with both the damage curve and the overload rating.
Yes
Yes
Paragraph 224 addresses R1.12, requiring documentation and making available a list of facilities that have protective relays set pursuant to R1.12. Although Order 733 was silent on R1.13, should the new R4 not also apply to R1.13?
No
We don't have Attachment B yet, and the standard development timeline has the standard being submitted to FERC in March of 2011, which we believe is an unreasonable timeline.
No
Attachment A has added 1.6 stating "Protective functions that supervise operation of other protective functions" is included in the standard. We would argue that it is not reasonable to include overcurrent fault detectors used to supervise distance elements or breaker failure schemes. These relays provide security to the protection scheme, such as for loss of potential conditions, and do not trip on their own. If these relays would be set per the standard, it would render the schemes ineffective for many fault conditions. In the case of electromechanical schemes, the supervising relay could be removed from service which could make the protection scheme misoperate. In the case of microprocessor relays, the supervising relay is embedded in logic and can't be removed.
No
Until we see the criteria for Attachment B, we can't agree that 39 months is sufficient time.

Yes
No
No
• The SAR states that Paragraph 162 is part of Phase I, but the new standard addressing stable power swings is Phase III.
No
No

## **Consideration of Comments on Revisions to Relay Loadability for Order 733 SAR and an initial set of proposed requirements — Project 2010-13**

The Revisions to Relay Loadability for Order 733 SAR Drafting Team thanks all commenters who submitted comments on the proposed SAR and an initial set of proposed requirements. The SAR and proposed standard were posted for a 30-day public comment period from August 19 through September 19, 2010. The stakeholders were asked to provide feedback on the standards through a special Electronic Comment Form. There were 36 sets of comments, including comments from more than 88 different people from approximately 36 companies representing 8 of the 10 Industry Segments as shown in the table on the following pages.

The Standard was posted for an “informal” comment period – the team provided a summary responses to the comments submitted on the proposed standard (Questions 1-8) and the SAR was posted for a “formal” comment period - and the team provided detailed responses to the comments submitted on the SAR (Questions 9-13)

### **Summary of Changes:**

The SDT revised sections 4.1.2 and 4.1.4 for consistency and to refer to facilities “determined by the Planning Coordinator to comply with this standard.”

The SDT added a new 4.1.3 “Transmission lines operated below 100 kV that Regional Entities have identified as critical facilities for the purposes of the Compliance Registry and are also determined by the Planning Coordinator as required to comply with this standard. ”

The SDT renumbered old 4.1.3 to 4.1.4.

The SDT renumbered old 4.1.4 to 4.1.5 and reverted the voltage threshold to the original text consistent with the modification to section 4.1.2.

The SDT added "4.1.6 Transformers with low voltage terminals connected below 100 kV that Regional Entities have identified as critical facilities for the purposes of the Compliance Registry and are also determined by the Planning Coordinator as required to comply with this standard."

In response to comments that Requirement R5 is confusing the SDT deleted “to prevent cascading when protective relay settings limit transmission loadability” from Requirement R5. Removing this does not change the intent of the requirement.

Commenters indicated for a variety of reasons that the requirement related to out-of-step blocking added to Requirement R1 is confusing. The SDT agrees and removed out-of-step blocking from Requirement R1. The requirement pertaining to evaluation of out-of-step blocking protection has been moved to a separate requirement (now Requirement R2) to more clearly delineate this requirement from assessment of relay loadability of phase protective relays.

Some commenters indicated that the word “settings” should be replaced throughout R1 when referring to a part, or sub-requirement of R1. The SDT modified Requirement R1 by replacing the word “settings” with “criteria.” This is consistent with the main Requirement R1 which in

the presently approved standard (PRC-023-1) refers to sub-requirements R1.1 through R1.13 as criteria to prevent phase protective relay settings from limiting transmission system loadability.

Some commenters identified an error in the draft standard in criterion 9 in Requirement R1 that resulted in omitting a phrase contained in the presently approved standard. The SDT modified criterion 9 in Requirement R1 to reinsert the deleted phrase.

IEEE C37.91 Figure A5 has two components to the thermal damage curve for through-faults: the “thermal component” begins at 2x the transformer nominal nameplate rating, and seems to be the root of commenters’ concerns. The “mechanical component” begins at a current equal to the reciprocal of the twice the transformer impedance. The commenters are correct in their characterization of the “thermal component” of the transformer damage curve, in that it is not possible to satisfy the posted PRC-023-2 R1, criterion 10 and also protect the transformer for currents in this region. Upon careful consideration of FERC Order 733, the SDT revised R1 criterion 10 to reference only the mechanical withstand capability.

Many commenters questioned the inclusion of “limiting piece of equipment” rather than “transformer”, as the fault-withstand capability of terminal equipment (switches, breakers, current transformers, etc) may be unavailable. Upon further consideration of FERC Order 733, the SDT modified criterion 10 by replacing “limiting equipment” with “transformer.”

The SDT modified the wording of R4 as follows. "Each Transmission Owner, Generator Owner, and Distribution Provider that chooses to utilize Requirement R1 criterion 2 as the basis for verifying transmission line relay loadability shall provide...." as a result of comments.

The SDT agreed to remove the Regional Entity from the list of entities receiving this information in Requirement R4.

One commenter noted that the SDT needs to work closely with the Reliability Coordination SDT (Project 2006-06) which is tasked with defining critical facilities or indentifying criteria for developing a list of critical facilities. The commenter disagreed with use of the phrase “facilities that are critical” in this requirement and cautioned that a requirement to create a list of critical facilities should not be addressed in this standard. The SDT notes that although the phrase “critical to reliability of bulk electric system” appears in the approved PRC-023-1 and is used in Order No. 733, the SDT recognizes that use of the same or similar terms in multiple standards will result in confusion. Use of the phrase “critical to reliability of the Bulk Electric System” in PRC-023 is intended to have meaning specific to the issue of relay loadability; specifically to identify facilities, that if they trip due to relay loadability following an initiating event, may contribute to undesirable system performance similar to what occurred during the August 2003 blackout. The SDT has modified the standard to replace the phrase “critical to the reliability of the bulk electric system” with “that must comply with this standard.” The SDT believes this will avoid potential confusion and that reliability will be adequately addressed because the criteria in PRC-023 - Attachment B identify all facilities that must be subject to this standard to maintain reliability of the Bulk Electric System.

One commenter noted that Requirement R5, Part 5.1 is unnecessary since the process to use the criteria in PRC-023 - Attachment B would almost certainly be to simply apply the criteria and

that requiring documentation of such a process will result in increased paperwork and additional preparation for an audit without a reliability benefit. The SDT agrees that this part of Requirement R5 is unnecessary and has removed it from the Standard.

Three-fourths of commenters believe the addition of section 1.6 in PRC-023 - Attachment A is not an equally efficient and effective method of meeting this directive. More than one-half of commenters believe that addressing the directive in the proposed manner will have a negative impact on reliability of the bulk electric system. The SDT agrees that addressing the directive in the manner proposed in the first posting will have the unintended consequence of impacting the dependability and security of certain protection systems. The SDT has revised the draft standard to address the following concerns noted by commenters.

- More than one-half of commenters noted that the proposed modification would require overcurrent fault detectors applied to supervise distance (impedance) elements to meet the relay loadability requirements which would have a detrimental impact on reliability. Setting these fault detectors to meet PRC-023 would restrict the ability of some distance elements to trip for end-of-zone faults, particularly on weak source systems. Eliminating the fault detector to avoid this concern would have the negative impact of making the protection system susceptible to undesired tripping during close-in faults on adjacent elements. Some commenters further noted that many microprocessor relays have inherent overcurrent supervision of impedance elements which cannot be disabled.
- Several commenters noted that the standard should apply to protective systems and not to individual components of protective systems and that compliance should be based on the ability of the protective system as a whole to meet the performance criteria established by the standard. Some commenters also noted that a clarification is required that “protective functions” applies only to those protective relay elements that would respond to non-fault or load conditions and could issue a direct trip.
- Some commenters noted their belief that the modification goes well beyond the Commission’s concern and they proposed alternatives they believe would be equally effective and efficient approaches to addressing the Commission’s reliability concerns.

In response to these concerns, in particular the negative impact on reliability associated with the proposed modification, the SDT has modified section 1.6 to include “1.6. Supervisory elements associated with current based communication assisted schemes where the scheme is capable of tripping for loss of communications.” The SDT also modified the second bulleted item in section 2.1 to add the clause, “except as noted in section 1.6 above.”

The SDT agrees with several commenters about the proposed language for Effective Dates and has changed the language to the following:

5.1. Requirement R1: the first day of the first calendar quarter after applicable regulatory approvals, except as noted below.

5.1.1 For the addition to Requirement R1, criterion 10, to set transformer fault protection relays and transmission line relays on transmission lines terminated only with a

transformer such that the protection settings do not expose the transformer to fault level and duration that exceeds its mechanical withstand capability, the first day of the first calendar quarter 12 months after applicable regulatory approvals.

5.1.2 For supervisory elements as described in Attachment A, section 1.6, the first day of the first calendar quarter following 24 months after applicable regulatory approvals.

5.2. Requirements R2 and R3: the first day of the first calendar quarter after applicable regulatory approvals.

5.3. Requirements R4 and R5: the first day of the first calendar quarter following 24 months after applicable regulatory approvals.

5.4. Requirement R6: the first day of the first calendar quarter 18 months after applicable regulatory approvals.

5.5. Requirement R7: the first day of the first calendar quarter after applicable regulatory approvals.

To address the need for entities to meet the requirements of the standard for facilities identified by the Planning Coordinator in the future, the SDT added a new requirement (R7).

Several commenters indicated that the directive from P. 224 is missing from the detailed section of the SAR, but is included in the table in the back of the SAR. This was an error in the SAR and the SDT has added this directive to the detailed section of the SAR for Phase I. The new Requirement R5 will support collection of the data necessary for the ERO to address the directive. The ERO will provide the data upon request, but outside of PRC-023.

[http://www.nerc.com/filez/standards/SAR\\_Project%202010-13\\_Order%20733%20Relay%20Modifications.html](http://www.nerc.com/filez/standards/SAR_Project%202010-13_Order%20733%20Relay%20Modifications.html)

If you feel that your comment has been overlooked, please let us know immediately. Our goal is to give every comment serious consideration in this process! If you feel there has been an error or omission, you can contact the Vice President and Director of Standards, Herb Schrayshuen, at 609-452-8060 or at herb.schrayshuen@nerc.net. In addition, there is a NERC Reliability Standards Appeals Process.<sup>1</sup>

---

<sup>1</sup> The appeals process is in the Reliability Standards Development Procedures: <http://www.nerc.com/standards/newstandardsprocess.html>.

## Index to Questions, Comments, and Responses

1.	The Applicability Section (4.1.2 and 4.1.4) and Requirement R5 (previously Requirement R3) have been modified to address the directive in Paragraph 60 of Order no. 733. Do you agree that this is an acceptable and effective method of meeting this directive? If not, please explain. ....	13
2.	R1 has been modified to address the directive in Paragraph 244 of Order no. 733. Do you agree that this is an acceptable and effective method of meeting this directive? If not, please explain. ....	19
3.	Requirement R1, setting 10 has been modified to address the directive in Paragraph 203 of Order no. 733. Do you agree that this is an acceptable and effective method of meeting this directive? If not, please explain. ....	25
4.	Requirement R3 has been added to address the directive in Paragraph 186 of Order no. 733. Do you agree that this is an acceptable and effective method of meeting this directive? If not, please explain. ....	29
5.	Requirement R4 has been added to address the directive in Paragraph 224 of Order no. 733. Do you agree that this is an acceptable and effective method of meeting this directive? If not, please explain. ....	33
6.	Requirement R5 and part 5.1 (previously Requirement R3 and part 3.1) have been modified to establish the framework to address the directive in Paragraph 69 of Order no. 733, although the criteria itself (which will be Attachment B) is still being developed. Do you agree that this is an acceptable and effective method of meeting this directive considering that Requirement R5 is establishing the construct to insert the criteria at a future time in the form of Attachment B? If not, please explain. ....	37
7.	Attachment A has been modified to address the directive in Paragraph 264 of Order no. 733. Do you agree that this is an acceptable and effective method of meeting this directive? If not, please explain. ....	44
8.	Do you agree that the SDT has addressed the remaining directives: Paragraph 284 to remove the footnote and Paragraph 283 to modify the implementation plan for sub-100 kV facilities (by revising the Effective Date section of the standard)? .....	54
9.	Do you agree that the scope of the proposed standards action addresses the directive or directives? .....	58
10.	Can you identify an equally efficient and effective method of achieving the reliability intent of the directive or directives?.....	63
11.	Do you agree with the scope of the proposed standards action? .....	68
12.	Are you aware of any regional variances that we should consider with this SAR? .....	74
13.	Are you aware of any associated business practices that we should consider with this SAR?.....	78



The Industry Segments are:

- 1 — Transmission Owners
- 2 — RTOs, ISOs
- 3 — Load-serving Entities
- 4 — Transmission-dependent Utilities
- 5 — Electric Generators
- 6 — Electricity Brokers, Aggregators, and Marketers
- 7 — Large Electricity End Users
- 8 — Small Electricity End Users
- 9 — Federal, State, Provincial Regulatory or other Government Entities
- 10 — Regional Reliability Organizations, Regional Entities

Group/Individual		Commenter	Organization	Registered Ballot Body Segment									
				1	2	3	4	5	6	7	8	9	10
1.	Group	Guy Zito	Northeast Power Coordinating Council	10									
<b>Additional Member</b>				<b>Additional Organization Region Segment Selection</b>									
1.	Alan Adamson	NY State Reliability Council	NPCC	10									
2.	Gregory Campoli	NY Independent System Operator	NPCC	2									
3.	Kurtis Chong	Independent Electricity System Operator	NPCC	2									
4.	Sylvain Clermont	Hydro-Quebec TransEnergie	NPCC	1									
5.	Gerry Dunbar	NPCC	NPCC	10									
6.	Brian Evans-Mongeon	Utility Services	NPCC	7									
7.	Dean Ellis	Dynegy Generation	NPCC	5									
8.	Brian L. Gooder	Ontario Power Generation	NPCC	5									

Group/Individual	Commenter	Organization	Registered Ballot Body Segment																	
			1	2	3	4	5	6	7	8	9	10								
9. Kathleen Goodman	ISO New England	NPCC	2																	
10. Chantel Haswell	FPL Group Inc	NPCC	5																	
11. David Kiguel	Hydro One Networks	NPCC	1																	
12. Michael R. Lombardi	Northeast Utilities	NPCC	1																	
13. Randy MacDonald	New Brunswick System Operator	NPCC	2																	
14. Bruce Metruck	NY Power Authority	NPCC	6																	
15. Lee Pedowicz	NPCC	NPCC	10																	
16. Robert Pellegrini	The United Illuminating Company	NPCC	1																	
17. Si Truc Phan	Hydro-Quebec TransEnergie	NPCC	1																	
18. Saurabh Saksena	National Grid	NPCC	1																	
19. Michael Schiavone	National Grid	NPCC	1																	
20. Peter Yost	Consolidated Edison of New York	NPCC	3																	
21. Mike Garton	Dominion Resources	NPCC	5																	
2.	Group	Richard Kafka	Pepco Holdings, Inc - Affiliates									1, 3, 5, 6								
<b>Additional Member</b>		<b>Additional Organization</b>	<b>Region</b>	<b>Segment Selection</b>																
1.	Alvin Depew	Potomac Electric Power Company	RFC	1																
2.	Carl Kinsley	Delmarva Power & Light Company	RFC	1																
3.	Evan Sage	Potomac Electric Power Company	RFC	1																

Consideration of Comments on Revisions to Relay Loadability for Order 733 SAR and an initial set of proposed requirements — Project 2010-13

Group/Individual	Commenter	Organization	Registered Ballot Body Segment																	
			1	2	3	4	5	6	7	8	9	10								
4.	Rob Wharton	Atlantic City Electric	RFC	1																
3.	Group	Kenneth D. Brown	PSEG Companies		1, 3, 5, 6															
	<b>Additional Member</b>	<b>Additional Organization</b>	<b>Region</b>	<b>Segment Selection</b>																
1.	Dave Murray	PSEG Power	RFC	5																
2.	Jim Hebson	PSEG ER &T	NPCC	6																
3.	Scott Slickers	PSEG Connecticut	NPCC	5																
4.	Jerzy Slusarz	Odessa power Partners	ERCOT	5																
5.	Jim Hubertus	PSEG	RFC	1,3																
4.	Group	Denise Koehn	Bonneville Power Administration		1, 3, 5, 6															
	<b>Additional Member</b>	<b>Additional Organization</b>	<b>Region</b>	<b>Segment Selection</b>																
1.	Dean Bender	BPA	WECC	1																
5.	Group	Doug Hohlbaugh	FirstEnergy		1, 3, 4, 5, 6															
	<b>Additional Member</b>	<b>Additional Organization</b>	<b>Region</b>	<b>Segment Selection</b>																
1.	Sam Ciccone	FE	RFC	1, 3, 4, 5, 6																
6.	Group	Ben Li	IRC Standards Review Committee		2															
	<b>Additional Member</b>	<b>Additional Organization</b>	<b>Region</b>	<b>Segment Selection</b>																
1.	Bill Phillips	MISO	MRO	2																
2.	Patrick Brown	PJM	RFC	2																
3.	James Castle	NYISO	NPCC	2																

Group/Individual		Commenter	Organization		Registered Ballot Body Segment									
					1	2	3	4	5	6	7	8	9	10
4.	Greg Van Pelt	CAISO	WECC	2										
5.	Charles Yeung	SPP	SPP	2										
6.	Steve Myers	ERCOT	ERCOT	2										
7.	Mark Thompson	AESO	WECC	2										
7.	Group	Carol Gerou	MRO's NERC Standards Review Subcommittee		10									
	<b>Additional Member</b>	<b>Additional Organization</b>	<b>Region</b>	<b>Segment Selection</b>										
1.	Mahmood Safi	Omaha Public Utility District	MRO	1,3,5,6										
2.	Chuck Lawrence	American Transmission Company	MRO	1										
3.	Tom Webb	WPS Corp	MRO	3,4,5,6										
4.	Jason Marshall	Midwest ISO	MRO	2										
5.	Jodi Jenson	Western Area Power Admin.	MRO	1,6										
6.	Ken Goldsmith	Alliant Energy	MRO	4										
7.	Dave Rudolph	Basin Electric Power Cooperative	MRO	1,3,5,6										
8.	Eric Ruskamp	Lincoln Electric System	MRO	1,3,5,6										
9.	Joseph Knight	Great River Energy	MRO	1,3,5,6										
10.	Joe DePoorter	Madison Gas & Electric	MRO	3,4,5,6										
11.	Scott Nickels	Rochester Public Utilities	MRO	4										
12.	Terry Harbour	Mid American Energy Co.	MRO	1,3,5,6										

Consideration of Comments on Revisions to Relay Loadability for Order 733 SAR and an initial set of proposed requirements — Project 2010-13

Group/Individual		Commenter	Organization		Registered Ballot Body Segment									
					1	2	3	4	5	6	7	8	9	10
8.	Group	Mike Garton	Dominion Electric Market Policy		1, 3, 5, 6									
	<b>Additional Member</b>	<b>Additional Organization</b>	<b>Region</b>	<b>Segment Selection</b>										
1.	Michael Gildea	Dominion Resource Services	NPCC	5										
2.	Louis Slade	Dominion Resource Services	SERC	6										
9.	Individual	Brent Ingebrigtsen	E.ON U.S. LLC		X		X		X	X				
10.	Individual	William Gallagher	Transmission Access Policy Study Group		X		X	X	X	X				
11.	Individual	Jana Van Ness, Director Regulatory Compliance	Arizona Public Service Company		X		X		X	X				
12.	Individual	Andrew Z. Pusztai	American Transmission Company		X									
13.	Individual	Sandra Shaffer	PacifiCorp		X		X		X	X				
14.	Individual	Andy Tillery	Southern Company		X		X							
15.	Individual	Bill Middaugh	TSGT System Planning Group		X									
16.	Individual	Gene Henneberg	NV Energy		X		X		X					
17.	Individual	Steve Wadas	NPPD		X									
18.	Individual	Joylyn Faust	Consumers Energy				X	X	X					
19.	Individual	Jonathan Meyer	Idaho Power - System Protection		X		X		X					

Consideration of Comments on Revisions to Relay Loadability for Order 733 SAR and an initial set of proposed requirements — Project 2010-13

Group/Individual		Commenter	Organization	Registered Ballot Body Segment									
				1	2	3	4	5	6	7	8	9	10
20.	Individual	Michael Gammon	Kansas City Power & Light	X		X		X	X				
21.	Individual	Dan Rochester	Independent Electricity System Operator		X								
22.	Individual	Bill Miller	ComEd	X		X		X					
23.	Individual	Kasia Mihalchuk	Manitoba Hydro	X		X		X	X				
24.	Individual	Brian Evans-Mongeon	Utility Services								X		
25.	Individual	Tribhuvan Choubey	Southern California Edison	X									
26.	Individual	Dale Fredrickson	Wisconsin Electric			X	X	X					
27.	Individual	Kathleen Goodman	ISO New England Inc.		X								
28.	Individual	Robert Ganley	Long Island Power Authority	X									
29.	Individual	Kirit Shah	Ameren	X		X		X	X				
30.	Individual	Thad Ness	American Electric Power	X		X		X	X				
31.	Individual	Michael Moltane	ITC Holdings	X									
32.	Individual	Not indicated	Not Indicated										
33.	Individual	Laura Zotter, Steve Myers	ERCOT ISO		X								
34.	Individual	RoLynda Shumpert	South Carolina Electric and Gas	X		X		X	X				

Group/Individual		Commenter	Organization	Registered Ballot Body Segment									
				1	2	3	4	5	6	7	8	9	10
35.	Individual	Jon Kapitz	Xcel Energy	X		X		X	X				
36.	Individual	Greg Rowland	Duke Energy	X		X		X	X				

- 1. The Applicability Section (4.1.2 and 4.1.4) and Requirement R5 (previously Requirement R3) have been modified to address the directive in Paragraph 60 of Order no. 733. Do you agree that this is an acceptable and effective method of meeting this directive? If not, please explain.**

**Summary Consideration:**

Several commenters wanted to know what is meant by “critical to the reliability of the Bulk Electric System (BES)”. The SDT notes that although the phrase “critical to reliability of bulk electric system” appears in the approved PRC-023-1 and is used in Order No. 733, the SDT recognizes that use of the same or similar terms in multiple standards will result in confusion. Use of the phrase “critical to reliability of the Bulk Electric System” in PRC-023 is intended to have meaning specific to the issue of relay loadability; specifically to identify facilities, that if they trip due to relay loadability following an initiating event, may contribute to undesirable system performance similar to what occurred during the August 2003 blackout. The SDT has modified the standard to replace the phrase “critical to the reliability of the bulk electric system” with “that must comply with this standard.” The SDT believes this will avoid potential confusion and that reliability will be adequately addressed because the criteria in Attachment B identify all facilities that must be subject to this standard to maintain reliability of the Bulk Electric System.

Several commenters indicated that the phrase "low voltage terminals" is open to interpretation. This term is part of the existing standard and not included in the scope of the SAR; however, Attachment B will clarify the criteria to determine which facilities must comply with the standard.

The SDT revised sections 4.1.2 and 4.1.4 for consistency and to refer to facilities “determined by the Planning Coordinator to comply with this standard.”

Commenters indicated that they did not believe the standard should apply to facilities below 100 kV; however, in Order 733, NERC was directed to apply PRC-023 to facilities below 100 kV, as well as 100 kV to 200 kV, and to provide criteria to establish which of those facilities to which PRC-023 was to apply. As noted with this posting, the criteria was posted for public comment and is intended to be included with the next posting of this standard.

Commenters indicated that they did not believe the standard should apply to facilities below 100 kV; however, in Order 733, NERC was directed to apply PRC-023 to facilities below 100 kV, as well as 100 kV to 200 kV, and to provide criteria to establish those facilities to which PRC-023 was to apply. As noted with this posting, the criteria were posted for public comment and will be included with the next posting of this standard.

Commenters were reluctant to offer a firm response to the proposed modifications without reviewing the proposed criteria in Attachment B. As noted with this posting, the criteria were posted for public comment and will be included with the next posting of this standard.

The SDT reverted the voltage threshold in section 4.1.2 to the original text because commenters suggested that only facilities below 100 kV that are on the Regional Entity’s list should be subjected to the criteria in Attachment B, while all facilities between 100 kV and 200 kV should be subject to the criteria in Attachment B.

The SDT added a new 4.1.3 “Transmission lines operated below 100 kV that Regional Entities have identified as critical facilities for the purposes of the Compliance Registry and are also determined by the Planning Coordinator as required to comply with this standard. ”

The SDT renumbered old 4.1.3 to 4.1.4.

The SDT renumbered old 4.1.4 to 4.1.5 and reverted the voltage threshold to the original text consistent with the modification to section 4.1.2.



The SDT added "4.1.6 Transformers with low voltage terminals connected below 100 kV that Regional Entities have identified as critical facilities for the purposes of the Compliance Registry and are also determined by the Planning Coordinator as required to comply with this standard."

In response to comments that Requirement R5 is confusing the SDT deleted "to prevent cascading when protective relay settings limit transmission loadability" from Requirement R5. Removing this term does not change the intent of the requirement.

Commenters indicated that the modifications to the applicability section may have the unintended consequence of increasing the burden on Distribution Providers (DPs) with no reliability benefit; however, 1) the proposed modifications are directed changes and 2) the DPs would only be affected if the Planning Coordinators apply the criteria in Attachment B and determine that the DPs have a facility that must comply with the standard.

One comment indicated that Requirement R1's VRF "High" has no justification. The SDT thinks that the revision to Requirement R1 to include below 200 kV facilities should have no impact on the VRF assignment. If a facility is designated as a facility critical to the reliability of the BES the impact on reliability is High regardless of the voltage level.

Some commenters noted the Reliability Coordinator (RC) is included in the SAR, but the SDT did not include the RC in the applicability section of the standard. The SDT notes that the SAR contains a list of entities that could potentially be included in the standard, but it is not necessary that the SDT include each entity in the applicability section of the standard.

Organization	Yes or No	Question 1 Comment
Northeast Power Coordinating Council	No	The revised Applicability paragraph 4.1.4 reads:4.1.4 Transformers with low voltage terminals connected below 200 kV as designated by the Planning Coordinator as critical to the reliability of the Bulk Electric System (BES). The phrase "low voltage terminals" is open to interpretation because some transformers have low-voltage terminals which are do not supply a load, or supply only local substation AC service. Sometimes the transformer is a 3-winding bank, with the low-voltage winding not used, or the low-voltage winding is used solely to provide additional grounding, as in the case of a delta-connected tertiary, unconnected to any load. Is this what is intended? If yes, then they should remove the ambiguity. Note the phrase "low-voltage" terminal was part of Revision 1 and is unchanged by Revision 2, however, the new applicability to below 200 kV raises the new concern. What is meant by "critical to the reliability of the Bulk Electric System (BES)"? Also, replace "as designated" with "and designated".Suggest 4.1.4 be revised to read:4.1.4 Transformers with low voltage terminals connected below 200 kV and designated by the Planning Coordinator as Critical Assets. Clarification is needed to explain the disconnect between FERC's "sub-100kV", and the proposed "below 200kV".
IRC Standards Review Committee	No	We believe this directive needs to be addressed by a full standards drafting team to ensure the precise language is crafted to adequately address the directive. Furthermore, we believe only the full standards drafting team could identify equally effective alternatives to the Commission's directives as they have made

Organization	Yes or No	Question 1 Comment
		<p>clear they allow in this Order and many others. Some immediate concerns with the proposal include: 1) It is not clear what a “critical facilities list identified by the Regional Entity” is as specified within the order so addressing the directive is a challenge. This standard is not the appropriate venue for development or consideration of a critical facilities list. There is a supplemental SAR in process for the Reliability Coordination project that is to address that topic. 2) Our understanding is that the application of NERC standards is limited to the BES. Thus, facilities below 100 kV must be included in the Regional Entity definition of BES to be eligible. The requirements should reflect this. The way the proposed standard reads, one might conclude the PC must test every facility below 100 kV. This surely can’t be the intent.3) Furthermore, the directive appears to require some action on the Regional Entities. From paragraph 60, “We also direct that additions to the Regional Entities’ critical facility list be tested for their applicability to PRC-023-1 and made subject to the Reliability Standard as appropriate.” It is not clear how this directive is reflected in the standard to ensure that this work is completed prior to the PC’s performing their assessment for below 200 kV facilities. This standard is not the appropriate venue to determine or revise a critical facilities list, nor is it appropriate for a Regional Entity to establish such a list. The bottom line is that the changes here are significant enough that they would benefit from a group of experts reviewing the directives and proposing the precise language that is needed.</p>
MRO's NERC Standards Review Subcommittee	No	<p>However, this response is conditional depending on whether the criteria that will be established within Attachment B (see R5.1) are reasonable and apply to properly qualified facilities below 200 kV.</p>
Dominion Electric Market Policy	No	<p>It depends on what Attachment B (R5.1) requires once it is developed. Without knowledge of the final content developed for Attachment B, we do not support this.</p>
E.ON U.S. LLC	No	<p>E.ON U.S. believes that it is confusing the way R5 is currently written due to the last part of the sentence “ ... when protective relay settings limit transmission loadability.” There is a need for clarification on how this is to be applied. As an alternative: If the directive is to have the Planning Coordinator determine which sub-100kV facilities should be subject to the Reliability Standard; R5 should be modified to read “Each Planning Coordinator shall apply the criteria in Attachment B to determine which of the facilities in its Planning Coordinator Area are to be included in 4.1.2 and 4.1.4.”</p>
Transmission Access Policy Study Group	No	<p>The modifications to the Applicability Section meet the FERC directive but have the unacceptable unintended consequence of increasing the burden on DPs with no reliability benefit. Specifically, the modifications make all DPs potentially subject to PRC-023, thus requiring all DPs to incur costs to determine whether the standard is applicable to them. Because PRC-023 should never be applicable to a DP in its capacity as a DP (as opposed to a TO that also happens to be registered as a DP), as explained in TAPS’ response to question 6 below, the SDT should simply remove DPs from the Applicability section to prevent the significant potential</p>

Organization	Yes or No	Question 1 Comment
		for confusion and unnecessary costs.
Arizona Public Service Company	No	Agree with the content. However, there is no justification for VRF to be High for the circuits lower than 200 kV.
Kansas City Power & Light	No	Agree the changes for 4.1.2 and 4.1.4 are effective in meeting the “add in” approach in the FERC order. However, do not agree with the approach in R5. R5 proposes to establish the criteria by which Reliability Coordinators will determine facilities critical to the reliability of the BES. There are a variety of differing, and often complex, operating conditions that dictate the need for transmission facilities. The TPL standards require extensive studies of the transmission system be performed under steady state and dynamic conditions to understand and identify sensitive areas of the transmission system and enable Reliability Coordinators to identify flowgates in their respective regions. In light of the Reliability Coordinators awareness of transmission sensitivities through these studies, it seems unnecessary to dictate to the Reliability Coordinators additional criteria.
Utility Services	No	The modifications to the Applicability Section meet the FERC directive but have the unacceptable unintended consequence of increasing the burden on DPs with no reliability benefit. Specifically, the modifications make all DPs potentially subject to PRC-023, thus requiring all DPs to incur costs to determine whether the standard is applicable to them. Because PRC-023 should never be applicable to a DP in its capacity as a DP (as opposed to a TO that also happens to be registered as a DP), as explained in our response to question 6 below, the SDT should simply remove DPs from the Applicability section to prevent the significant potential for confusion and unnecessary costs.
ISO New England Inc.	No	We believe this directive needs to be addressed by a full standards drafting team to ensure the precise language is crafted to adequately address the directive. Furthermore, we believe only the full standards drafting team could identify equally effective alternatives to the Commission’s directives as they have made clear they allow in this Order and many others. Some immediate concerns with the proposal include: 1) Our understanding is that the application of NERC standards is limited to the BES. Thus, facilities below 100 kV must be included in the Regional Entity definition of BES to be eligible. The requirements should reflect this. The way the proposed standard reads, one might conclude the PC must test every facility below 100 kV. This surely can’t be the intent.2) Furthermore, the directive appears to require some action on the Regional Entities. From paragraph 60, “We also direct that additions to the Regional Entities’ critical facility list be tested for their applicability to PRC-023-1 and made subject to the Reliability Standard as appropriate.” It is not clear how this directive is reflected in the standard to ensure that this work is completed prior to the PC’s performing their assessment for below 200 kV facilities. The bottom line is that the changes here are significant enough that they would benefit from a group of experts reviewing the directives and proposing the precise language that is needed.

Organization	Yes or No	Question 1 Comment
Long Island Power Authority	No	There appears to be a disconnect between FERC’s “sub 100 kV” and proposed “below 200 kV” revision in the Applicability Section. LIPA seeks clarification on this. Also, by whom and by which method will the criticality of the substations be ascertained?
Ameren	No	Attachment B as mentioned in R5 is not available for review.
American Electric Power	No	AEP understands the intent of the FERC Order (Paragraph 60) to address the sub-100 KV facilities only if they are associated with critical facilities above 100 KV. The applicability and the associated requirements should be reworded to ensure that the Planning Coordinator does not have to identify critical facilities below 100 KV.
Southern California Edison	No	Applicability clause 4.12 and 4.14 - Formulating a consistent methodology test to determine for a sub 200KV facility by the Planning Coordinator is quite an uphill task keeping in view the different circuit configuration different utilities may have. It is best left alone to each utility to determine the facilities which can be a candidate for inclusion as a bulk power system. The current risk based assessment criteria to determine bulk power facility should be continued.
American Transmission Company	Yes	However, this affirmative response is conditional depending on whether the criteria that will be established within Attachment B (see R5.1) are reasonable and apply to properly qualified facilities below 200 kV.
Pepco Holdings, Inc - Affiliates	Yes	While philosophically we do not agree that this standard should apply to facilities below 100kV (i.e. facilities that are not defined as BES facilities) we believe that as long as a sound engineering methodology is developed and applied uniformly to identify those facilities critical to the reliability of the BES, then the revised wording is acceptable. Our response, however, is qualified based on being granted an opportunity to comment and vote on the methodology once it is developed.
NPPD	Yes	As long as you keep BES.
Independent Electricity System Operator	Yes	We agree with the Applicability Section and the modification to R5. Note that there is a discrepancy between the entities listed in the Applicability Section and those checked off in the SAR. The latter indicates that the SAR is also applicable to the RC, which we do not believe is required.
Bonneville Power Administration	Yes	
FirstEnergy	Yes	

Organization	Yes or No	Question 1 Comment
PacifiCorp	Yes	
Southern Company	Yes	
TSGT System Planning Group	Yes	
NV Energy	Yes	
Consumers Energy	Yes	
Idaho Power - System Protection	Yes	
ComEd	Yes	
Manitoba Hydro	Yes	
ITC Holdings	Yes	
	Yes	
Xcel Energy	Yes	
Duke Energy	Yes	
Wisconsin Electric		No comment

2. R1 has been modified to address the directive in Paragraph 244 of Order no. 733. Do you agree that this is an acceptable and effective method of meeting this directive? If not, please explain.

**Summary Consideration:**

Commenters indicated for a variety of reasons that the requirement related to out-of-step blocking added to Requirement R1 is confusing. The SDT agrees and removed out-of-step blocking from Requirement R1. The requirement pertaining to evaluation of out-of-step blocking protection has been moved to a separate requirement (now Requirement R2) to more clearly delineate this requirement from assessment of relay loadability of phase protective relays.

One commenter noted that it is not clear how loadability requirements apply during fault conditions. In the new requirement the SDT clarified that the evaluation must ensure that out-of-step blocking elements allow tripping of phase protective relays for faults that occur during the loading conditions used to verify transmission line relay loadability per Requirement R1.

Some commenters indicated that the word “settings” should be replaced throughout R1 when referring to a part, or sub-requirement of R1. The SDT modified Requirement R1 by replacing the word “settings” with “criteria.” This is consistent with the main Requirement R1 which in the presently approved standard (PRC-023-1) refers to sub-requirements R1.1 through R1.13 as criteria to prevent phase protective relay settings from limiting transmission system loadability.

Some commenters identified an error in the draft standard in criterion 9 in Requirement R1 that resulted in omitting a phrase contained in the presently approved standard. The SDT modified criterion 9 in Requirement R1 to reinsert the deleted phrase.

One commenter noted that this directive needs to be addressed by a full standard drafting team to adequately address this directive and identify equally effective alternatives to the Commission’s directives. The Relay Loadability Standard Drafting Team that developed PRC-023-1 has been reconvened to address the directed modifications to the standard. The SDT believes that the issues identified in Order No. 733 can be addressed adequately by this SDT with industry stakeholder input through the NERC Standard Development Process.

One commenter indicated that they agreed with the inclusion of Section 2 of Attachment A in the Requirement Section but the proposed modification may not fully meet the directive that the additional requirement is assigned a VRF and VSL. This may require the creation of a separate main requirement rather than simply including the condition as a part of a requirement. However, the VRFs and VSLs are associated directly with R1, and thus all its’ subparts/criteria. Therefore, as Attachment A is referenced as being part of R1, the R1 VRFs and VSLs automatically apply.

Organization	Yes or No	Question 2 Comment
Northeast Power Coordinating Council	No	1. The last sentence in R1 should be revised to read: Each Transmission Owner, Generator Owner, and Distribution provider shall evaluate relay loadability at 0.85 per unit voltage, and a power factor angle of 30 degrees.  2. Settings are to be applied as listed following:“Setting” should be replaced throughout R1 when referring to

Organization	Yes or No	Question 2 Comment
		<p>a part, or sub-requirement of R1. The terminology should be whatever is preferred by NERC.Requirement R1, Parts 7, 8 and 9:</p> <p>3. Requirement R1, Parts 7, 8 and 9, replace the phrase “under any system configuration” with "under any system condition." 7. Set transmission line relays applied at the load center terminal, remote from generation stations, so they do not operate at or below 115% of the maximum current flow from the load to the generation source under any system condition.8. Set transmission line relays applied on the bulk system-end of transmission lines that serve load remote to the system so they do not operate at or below 115% of the maximum current flow from the system to the load under any system condition.9. Set transmission line relays applied on the load-end of transmission lines that serve load remote to the bulk system so they do not operate at or below 115% of the maximum current flow from the [____] to the under any system condition. [Brackets added, also see further comment on missing wording following]This phrase "under any system configuration" could be construed as being too all-inclusive, as one could postulate multiple events, e.g., simultaneous outages, which however unlikely could permit power flows in a direction for which the system was not originally designed. As with the second comment below, the phrase "under any system condition" was part of Revision 1 and is unchanged by Revision 2, however, the new applicability to below 200 kV creates the new concern.</p> <p>4. Requirement 1, part 9:As currently written, Requirement 1, part 9 states:9. Set transmission line relays applied on the load-end of transmission lines that serve load remote to the bulk system so they do not operate at or below 115% of the maximum current flow from the [____] to the under any system configuration. [Brackets added]Some words are missing. The brackets have been added above to show one place where at least some of the needed wording may be missing. A rewrite is necessary in order for this sentence to make any sense.</p>
Pepco Holdings, Inc - Affiliates	No	The revised wording in paragraph R1 regarding out-of-step blocking schemes is confusing. We suggest rewording the paragraph by splitting the sentence as follows: ...while maintaining reliable protection of the BES for all fault conditions. Use of out-of-step blocking schemes shall be evaluated to ensure that they do not block tripping for faults during the loading conditions defined within these requirements.
Bonneville Power Administration	No	The modified Requirement R1 requires that one of the 13 criteria be used to prevent out-of-step blocking schemes from blocking tripping for fault conditions. The problem is that the 13 criteria are only related to loading conditions, and it is not clear how they would be applied to prevent out-of-step blocking schemes from blocking a trip during a fault, or if it is even possible to use these criteria for this purpose. The modified Requirement R1 requires actions that are ambiguous and we cannot support it as written.
IRC Standards Review	No	We believe this directive needs to be addressed by a standards drafting team to ensure the precise language is crafted to adequately address the directive. Furthermore, we believe only the full standards drafting team

Organization	Yes or No	Question 2 Comment
Committee		could identify equally effective alternatives to the Commission’s directives as they have made clear they allow in this Order and many others.
E.ON U.S. LLC	No	Since correct operation of the out-of-step blocking feature is integral to and only a single component of a successful trip operation (for fault conditions), this is already included in the requirement to “maintain reliable protection of the BES for all fault conditions” and does not have to be mentioned separately. Also, R1 (as written) may be interpreted to require one of the settings (1 through 13) to be used to prevent out-of-step blocking schemes from blocking tripping for fault conditions. But Settings 1 thru 13 do not address specific setting criteria for out-of-step blocking.
TSGT System Planning Group	No	We suggest that the added phrase be removed from R1 and a new requirement created. Suggested wording is “Protection Systems that block for stable swings or out-of-step conditions shall be evaluated to ensure that appropriate tripping will occur for in-section faults that occur during the condition. Some additional delay may be required and is acceptable to ensure that the appropriate tripping occurs.”
NV Energy	No	<p>The proposed phrase added to R1 is only a start: “. . . , and to prevent its out-of-step blocking schemes from blocking tripping for fault conditions.” The specific wording proposed by the Drafting Team may prevent using the out-of-step-block functions of many modern and widely used line protection relays (e.g. SEL-321 and later models and GE-UR). These relay’s OSB function first blocks the protection elements from tripping, then uses a short delay and/or other information to determine whether the observed and perhaps evolving condition really represents a fault, in which case the blocking is reset to allow tripping. Such a block/reset operation is the most common technology available and would appear to lie within the intent of FERC in paragraph 244, but could be excluded by the presently proposed language. If an out-of-step blocking phrase is inserted in Requirement R1 of the standard, the emphasis should be modified to read something like: “. . . , and its out-of-step blocking schemes must allow tripping for fault conditions.” This standard should also require that out-of-step blocking settings coordinate with both the loadability and protection characteristics. The out-of-step blocking references would seem to fit best within the organization of the standard if included as a new Requirement R2 (FERC’s paragraph 244 anticipates “. . . an additional Requirement . . .”), with re-numbering of the proposed R2 through R5 as R3 through R6. The essential content of the DT’s proposed phrase in R1 would be included as part of this new R2, which would read something like: R2. Each Transmission Owner, Generator Owner, and Distribution Provider shall evaluate its out-of-step blocking schemes to ensure that both: R2.1. Out-of-step blocking schemes allow tripping for fault conditions during the loading conditions determined from Requirement R1 parts R1.1 through R1.13. R2.2. Relay out-of-step blocking settings coordinate with both the relay loadability characteristic determined from Requirement R1 parts R1.1 through R1.13 and the facility protection settings. The Measure for this proposed R2 would read something like: M2. The Transmission Owner, Generator Owner, and Distribution Provider with out-of-step blocking schemes shall have evidence such as spreadsheets or</p>



Organization	Yes or No	Question 2 Comment
		<p>summaries of calculations to show that each of its out-of-step blocking schemes is set to comply with the requirements of R2.1 and R2.2. The VSL for R1 would not change; specifically it would not reference out-of-step blocking schemes. The VSL for this proposed new R2 would be “Severe” and read something like: A Transmission Owner, Generator Owner, or Distribution Provider did not allow its out-of-step blocking schemes to trip for fault conditions during the loading conditions determined from Requirement R1 parts R1.1 through R1.13. ORA Transmission Owner, Generator Owner, or Distribution Provider did not coordinate operation of its out-of-step blocking schemes with both the relay loadability characteristic determined from Requirement R1 parts R1.1 through R1.13 and the facility protection settings.</p>
Independent Electricity System Operator	No	<p>We agree with the inclusion of Section 2 of Attachment A in the Requirement Section but the proposed modification may not fully meet the directive that the additional requirement is assigned a VRF and VSL. This may require the creation of a separate main requirement rather than simply including the condition as a part of a requirement.</p>
Southern California Edison	No	<p>Requirement R1.7, R1.8, R1.13 do not provide a clear guideline on generators connected to the load center on Radial basis, where load current into the generators ( forward direction current seen by the relay) is just an auxiliary load and insignificant compared to the transmission line rating.</p>
ISO New England Inc.	No	<p>Requirement R1, Parts 7, 8 and 9: Requirement R1, Parts 7, 8 and 9, replace the phrase “under any system configuration” with "under any system condition:" 7. Set transmission line relays applied at the load center terminal, remote from generation stations, so they do not operate at or below 115% of the maximum current flow from the load to the generation source under any system condition. 8. Set transmission line relays applied on the bulk system-end of transmission lines that serve load remote to the system so they do not operate at or below 115% of the maximum current flow from the system to the load under any system condition. 9. Set transmission line relays applied on the load-end of transmission lines that serve load remote to the bulk system so they do not operate at or below 115% of the maximum current flow from the [___] to the under any system condition. [Brackets added, also see further comment on missing wording following] This phrase "under any system configuration" could be construed as being too all-inclusive, as one could postulate multiple events, e.g., simultaneous outages, which however unlikely could permit power flows in a direction for which the system was not originally designed. As with the second comment below, the phrase "under any system condition" was part of Revision 1 and is unchanged by Revision 2, however, the new applicability to below 200 kV creates the new concern. Requirement 1, part 9: As currently written, Requirement 1, part 9 states: 9. Set transmission line relays applied on the load-end of transmission lines that serve load remote to the bulk system so they do not operate at or below 115% of the maximum current flow from the [___] to the under any system configuration. [Brackets added] Some words are missing. The brackets have been added above to show one place where at least some of the needed wording may be missing. A rewrite is</p>

Organization	Yes or No	Question 2 Comment
		necessary in order for this sentence to make any sense.
Long Island Power Authority	No	Requirement R1, Parts 7, 8 and 9, replace the phrase "under any system configuration" with "under any system condition:" This phrase "under any system configuration" could be construed as being too all-inclusive, as one could postulate multiple events, e.g., simultaneous outages, which however unlikely could permit power flows in a direction for which the system was not originally designed. Requirement 1, part 9:As currently written, Requirement 1, part 9 states:9. Set transmission line relays applied on the load-end of transmission lines that serve load remote to the bulk system so they do not operate at or below 115% of the maximum current flow from the [____] to the under any system configuration. [Brackets added] Some words are missing. The brackets have been added above to show one place where at least some of the needed wording may be missing. A rewrite is necessary in order for this sentence to make any sense.
ITC Holdings	No	The proposed wording seems out of place in this requirement and is not clear as how it is being applied to subrequirements 1 - 13
NPPD	Yes	I'm ok with that. It could have easily been left in Attachment A. You didn't bring the other language from attachment A to R1. You could of created a separate requirement for OOS, but I'm fine with moving it to R1.
FirstEnergy	Yes	
MRO's NERC Standards Review Subcommittee	Yes	
Dominion Electric Market Policy	Yes	
Arizona Public Service Company	Yes	
American Transmission Company	Yes	
Southern Company	Yes	
Consumers Energy	Yes	
Idaho Power - System Protection	Yes	

Organization	Yes or No	Question 2 Comment
Kansas City Power & Light	Yes	
ComEd	Yes	
Manitoba Hydro	Yes	
Ameren	Yes	
American Electric Power	Yes	
	Yes	
Xcel Energy	Yes	
Duke Energy	Yes	
Wisconsin Electric		No comment

**3. Requirement R1, setting 10 has been modified to address the directive in Paragraph 203 of Order no. 733. Do you agree that this is an acceptable and effective method of meeting this directive? If not, please explain.**

**Summary Consideration:**

Many commenters were concerned about the coordination with the relay loadability requirements of R1 – criterion 1.10 with the transformer damage curve as expressed in IEEE C37.91 Figure A4, which defines transformer through-fault withstand capability as starting at twice the nominal nameplate rating; R1, criterion 1.10 requires that loadability be 150% of the maximum nameplate (which itself is often 1.66 times the nominal nameplate – resulting in loadability of over 2.5 times the nominal nameplate rating).

IEEE C37.91 Figure A5 has two components to the thermal damage curve for through-faults: the “thermal component” begins at 2x the transformer nominal nameplate rating, and seems to be the root of commenters’ concerns. The “mechanical component” begins at a current equal to the reciprocal of the twice the transformer impedance. The commenters are correct in their characterization of the “thermal component” of the transformer damage curve, in that it is not possible to satisfy the posted PRC-023-2 R1, criterion 10 and also protect the transformer for currents in this region. Upon careful consideration of FERC Order 733, the SDT revised R1 criterion 10 to reference only the mechanical withstand capability.

Many commenters questioned the inclusion of “limiting piece of equipment” rather than “transformer”, as the fault withstand capability of terminal equipment (switches, breakers, current transformers, etc) may be unavailable. Upon further consideration of FERC Order 733, the SDT modified criterion 10 by replacing “limiting equipment” with “transformer.”

Organization	Yes or No	Question 3 Comment
Pepco Holdings, Inc - Affiliates	No	It would appear that this requirement has already been addressed in the R1 introductory paragraph by the phrase “...while maintaining reliable protection of the BES for all fault conditions.” How could one “maintain reliable protection of the BES” if relays are set with operating times that result in equipment being exposed to fault levels and durations that exceed their capability. This introductory requirement to provide reliable fault protection applies to all sub requirements not just to section 10 (old R1.10). As such, the added language in section 10 seems redundant and superfluous. Secondly, if the proposed language were to remain in section 10, why is the term “limiting piece of equipment” used and not just “transformer”? It appears the major concerns related to the comments contained in Order 733 were around exceeding transformer fault level/duration limitations. If that is the concern, why not just use the phrase “do not expose the transformer to fault levels and durations that exceeds its capability”
Bonneville Power Administration	No	In some cases, Section 10 of Requirement R1 would be impossible to meet. For example, a 150/200/250 MVA, OA/FOA1/FOA2 transformer is required by Section 10 to have its protection set so that it doesn’t operate at or below 150% of the maximum transformer rating of 250MVA, or 1.5x250=375MVA. The modified Section 10 would also require that the protection not expose the transformer to a fault level and duration that

Organization	Yes or No	Question 3 Comment
		exceeds its capability. According to IEEE C37.91, a through-fault of two times the transformers base rating, 2x150=300MVA, will be damaging to the transformer. For this particular transformer, which is not unusual, Requirement R1, Section 10, requires the protection to operate for through faults of 300MVA or greater, but not operate for loads of 375MVA or less. It is impossible to simultaneously meet both of these conditions, so Section 10 is unacceptable. One possible way to correct the problem is to change the requirement so that the protection does not operate below 200% of the transformer base rating. This would allow the protection to meet IEEE C37.91 for through-faults and still allow overloading of the transformer.
FirstEnergy	No	Although it is true that the FERC directive specifically states "limiting piece of equipment" their reasons and justifications all involve transformers. We propose replacing "limiting piece of equipment" with "transformer" would meet the FERC's reliability concern as well as provide clarity to applicable entities. We believe this is an equally effective means of meeting the directive.
IRC Standards Review Committee	No	We believe this directive needs to be addressed by a full standards drafting team to ensure the precise language is crafted to adequately address the directive. Furthermore, we believe only the full standards drafting team could identify equally effective alternatives to the Commission's directives as they have made clear they allow in this Order and many others. Additionally, we question if this directive should be addressed in the FAC standards rather than in PRC-023.
MRO's NERC Standards Review Subcommittee	No	The word change meets the strict interpretation of the directive, but it is not necessarily improving the reliability of the system. Faults are cleared in cycles and transformer damage curves do not start until at least one second
Dominion Electric Market Policy	No	The requirement is not clear. For example, how do we determine and verify the limiting piece of equipment under fault conditions? It might be a splice or a jumper. Since the document refers to duration, this seems to apply mainly to transformer overcurrent relaying which would be for overload protection not fault protection that has no intentional delay.
E.ON U.S. LLC	No	E.ON U.S. is concerned that the proposal requires a fault protection scheme separate from the phase overload relays. With the phase overload relays set at 150% of the maximum transformer nameplate, they (by themselves) will not be able to coordinate with the transformer damage curve (as defined by IEEE) for low level faults. R1, Section 10 meets the directive of Paragraph 203; however it is not clear that Section 10 only applies when there is no high side breaker at the transformer, as discussed in Order No. 733. E.ON U.S. recommends that an exclusion of the transmission line relay settings should be considered when transformer overload protection is provided by other means (i.e. A low side breaker trip or a direct transfer trip of the remote breaker initiated by an overload relay installed on the transformer).

Organization	Yes or No	Question 3 Comment
NPPD	No	Setting the relay to 150% of a 336MVA or 500MVA transformer can force you to cross the transformer damage curve and now your transformer is at risk to loss of life.
Idaho Power - System Protection	No	The reworded Requirement should to be clarified. The fault level and duration that the limiting element will be exposed can be a function of fault location and contingencies, such as relay failures, that are not addressed or defined. No measure is specified in the reliability standard that will demonstrate compliance with the revised requirements in R1.10.
Kansas City Power & Light	No	Although setting #10 includes language to protect the most limiting element for a transmission circuit ending with a transformer, the relay settings in the bulleted items are absent any consideration for other elements such as disconnect switches, wave traps, current transformers, potential transformers, etc. and are only with concern to the transformer. The relay settings should consider the fault current capabilities of all the facilities involved and be set in magnitude and duration of the lowest facility rating.
Ameren	No	The language is not clear. It appears that the transmission line relays are being used as the thermal overload protection for the transformer.
ITC Holdings	No	R1 -10 is all about loadability of the relays protecting the transformer. If the requirements of R1-10 cannot be met without exceeding the transformer damage curve, then we go to R1-11. We do not feel that there should be anything to do with fault duty.
Duke Energy	No	R1.10 has added the requirement that protection settings can't expose transformers to fault levels and durations that exceeds its capability, while at the same time not operate at or below 115% of highest emergency rating. We would argue that an overcurrent relay cannot be set to satisfy both requirements. A transformer's through-fault protection curve (C37.91) begins at 200% of the transformers self-cooled rating. The highest emergency rating is commonly 150% (or higher) of the transformer's highest (cooled) rating. Overcurrent relays could not be set to coordinate with both the damage curve and the overload rating.
South Carolina Electric and Gas	No	This requirement needs to be refined to clearly state the intent. It is unclear if "limiting piece of equipment" is referring to just transformers or other elements. Some of the elements involved in the construction of a transmission line/transformer arrangement such as line conductors, etc. may not have published fault current ratings. It is unclear how to determine the most limiting piece of equipment if published fault current ratings are not available for these devices
American Transmission	Yes	The word change meets the strict interpretation of the directive, but it is not necessarily improving the reliability of the system. Faults are cleared in cycles and transformer damage curves do not start until at least

Organization	Yes or No	Question 3 Comment
Company		one second.
Arizona Public Service Company	Yes	
Northeast Power Coordinating Council	Yes	
PacifiCorp	Yes	
Southern Company	Yes	
TSGT System Planning Group	Yes	
NV Energy	Yes	
Consumers Energy	Yes	
ComEd	Yes	
Manitoba Hydro	Yes	
ISO New England Inc.	Yes	
Long Island Power Authority	Yes	
American Electric Power	Yes	
	Yes	
Xcel Energy	Yes	
Wisconsin Electric		No comment

**4. Requirement R3 has been added to address the directive in Paragraph 186 of Order no. 733. Do you agree that this is an acceptable and effective method of meeting this directive? If not, please explain.**

**Summary Consideration:**

The SDT modified the wording of R4 as follows. "Each Transmission Owner, Generator Owner, and Distribution Provider that chooses to utilize Requirement R1 criterion 2 as the basis for verifying transmission line relay loadability shall provide...." as a result of comments.

The SDT agreed to remove the Regional Entity from the list of entities receiving this information in Requirement R4.

Comments indicated that all relay setting limitations should be included in the Facility Rating per FAC-008. The operator will then be made aware of any and all relay limitations through the use of those ratings (FAC-009). FERC Order 733 paragraph 186 requires an additional notification of relay setting limitations specifically for relay settings that are set based upon the 15 minute criteria. This is being done to ensure that transmission operators have knowledge of which facilities have relays set using a 15 minute criteria and which facilities have relays set using a 4-hour criteria. The SDT believes that requiring periodic submittals of this information will help create a clear and less ambiguous requirement and improve measurability which should aid applicable entities in compliance and result in more uniform enforcement actions.

Organization	Yes or No	Question 4 Comment
Bonneville Power Administration		This change adds an additional burden to the applicable entities, but serves no purpose other than to satisfy FERC’s misinterpretation of what a fifteen-minute facility rating is.
ERCOT ISO		The entities who receive the list of facilities should be the same from R3 to R4.
Northeast Power Coordinating Council	No	Referring to the response to Question 2 above, “Setting” should be replaced with Part, or Sub-requirement, whichever is the terminology preferred by NERC to use.
Pepco Holdings, Inc - Affiliates	No	To avoid confusion, the wording of R3 should be revised as follows: “Each Transmission Owner, Generator Owner, and Distribution Provider that chooses to utilize Requirement R1 Setting 2 as the basis for verifying transmission line relay loadability shall provide....” The problem with the SDT’s proposed wording of R3 is that suppose a TO chose to utilize R1 Setting 1 criteria (> 150% of 4 hr rating) as their basis for verifying loadability, but the actual relay setting also satisfied criteria R1 Setting 2 (> 115% of 15 min rating) the entity may interpret that they are still obligated to forward the list since the relay settings also satisfied R1 Setting 2 criteria
FirstEnergy	No	We suggest removing the Regional Entity from the list of entities receiving this information since they do not have a reliability-related need for it.



Organization	Yes or No	Question 4 Comment
IRC Standards Review Committee	No	We do not understand the need for this directive or requirement. A relay that is set to operate at 115% greater than the 15-minute rating of the facility does not equate to damage occurring on that facility if operated at that point in 15 minutes. Furthermore, it does not mean the relay will operate in 15 minutes nor does it mean the operator has only 15 minutes to take action. In fact, the operator may have less time depending on the time delay set on the relay. It is no different than any other relay. Usually, the facility will be operated with some buffer so that there is no chance that an entity could trip the facility due to loading above the relay limit. In fact, the transmission operator should be aware of any relay that might be the limiting facility so they can operate the facility with some margin of error to ensure they don't inadvertently cause a relay operation due to loading.
TSGT System Planning Group	No	We think that the data needs to be given only to the Transmission Operators, which is what FERC Order No. 733 requires. We also believe that an initial submittal is sufficient until any responsible entity begins or stops using Requirement 1, Setting 2 for setting a phase protective relay that is used to protect an applicable facility. There is no need for periodic duplicate submittals.
Kansas City Power & Light	No	Do not agree that the Regional Entity be included as a recipient of the list of transmission facilities. By NERC definition, the Regional Entity is the Compliance Monitor and Enforcement Authority for the NERC Reliability Standards and is not an operating entity. It is inappropriate to include Regional Entities as an entity to provide this information outside of the audit process established by the NERC Rules of Procedure. By definition, in the NERC Reliability Terminology, the Regional Entity is a compliance enforcement agent and not an operating organization of the Bulk Power System, and, therefore, has no operating reason to obtain this information. See definition below:Regional Entity - The term 'regional entity' is defined in Section 215 of the Federal Power Act means an entity having enforcement authority pursuant to subsection (e)(4) [of Section 215]. A regional entity (RE) is an entity to which NERC has delegated enforcement authority through an agreement approved by FERC. There are eight RE's. The regional entities were formed by the eight North American regional reliability organizations to receive delegated authority and to carry out compliance monitoring and enforcement activities. The regional entities monitor compliance with the standards and impose enforcement actions when violations are identified.
Independent Electricity System Operator	No	The proposed revision goes beyond what's asked for in the directive as it requires the responsible entities to provide the list to entities other than the TOP. The directive asks for providing the list to the TOP only.
Southern California Edison	No	The relay if set according to Requirement R1.2 are based upon 15 minute highest seasonal facility loading duration. This gives sufficient time for the operators to take manual corrective action, if the deem so. There is no need for the Registered entity to provide a list, as it would not be efficient and cost effective.

Organization	Yes or No	Question 4 Comment
ISO New England Inc.	No	We do not understand the need for this directive or requirement. A relay that is set to operate at 115% greater than the 15-minute rating of the facility does not equate to damage occurring on that facility if operated at that point in 15 minutes. Furthermore, it does not mean the relay will operate in 15 minutes nor does it mean the operator has only 15 minutes to take action. In fact, the operator may have less time depending on the time delay set on the relay. It is no different than any other relay. Usually, the facility will be operated with some buffer so that there is no chance that an entity could trip the facility due to loading above the relay limit. In fact, the transmission operator should be aware of any relay that might be the limiting facility so they can operate the facility with some margin of error to ensure they don't inadvertently cause a relay operation due to loading.
MRO's NERC Standards Review Subcommittee	Yes	
Dominion Electric Market Policy	Yes	
E.ON U.S. LLC	Yes	
Arizona Public Service Company	Yes	
American Transmission Company	Yes	
PacifiCorp	Yes	
Southern Company	Yes	
NV Energy	Yes	
NPPD	Yes	
Consumers Energy	Yes	
Idaho Power - System Protection	Yes	

Organization	Yes or No	Question 4 Comment
ComEd	Yes	
Manitoba Hydro	Yes	
Long Island Power Authority	Yes	
Ameren	Yes	
American Electric Power	Yes	
ITC Holdings	Yes	
	Yes	
Xcel Energy	Yes	
Duke Energy	Yes	
Wisconsin Electric		No comment

**5. Requirement R4 has been added to address the directive in Paragraph 224 of Order no. 733. Do you agree that this is an acceptable and effective method of meeting this directive? If not, please explain.**

**Summary Consideration:**

The FERC Order “direct(s) the ERO to document, subject to audit by the Commission, and to make available for review to users, owners and operators of the Bulk-Power System, by request, a list of those facilities that have protective relays set pursuant sub-requirement R1.12.”

Since the data is subject to audit, the SDT interprets this to mean that the ERO must gather and have continuously available a list of facilities using Requirement R1 criterion 12. The SDT therefore interprets the “by request” nature of the directive to indicate the way the ERO makes the list available to users, owners and operators of the Bulk-Power System, not how the ERO gathers the data from TOs, GOs and DOs.

As suggested by one of the comments, the SDT intended for registered entities to provide this data to their Regional Entities who would in turn provide it to the ERO. Although some comments have suggested other ways to accomplish this, the majority of responders appear to agree with the SDT proposed method.

Organization	Yes or No	Question 5 Comment
ERCOT ISO		The entities who receive the list of facilities should be the same from R3 to R4.
Northeast Power Coordinating Council	No	R4 addresses the directive, but as commented on previously, “Setting” should be replaced with Part, or Sub-requirement, whichever is the terminology preferred by NERC to use.
IRC Standards Review Committee	No	The objective of R4 as written is unclear and does not conform with the results-based concept in that it does not clearly specify a reliability directive. We suggest removing this requirement altogether as we do not believe this should be an on-going enforceable requirement. Rather, we think it makes more sense for NERC to use section 1600 of its Rules of Procedure to request the data. We believe that NERC and the Commission will likely determine that they don’t need to continually receive this data after reviewing it the first time. Nothing in the directive indicates this must be accomplished through a standard. If NERC and FERC do identify a continuing need for the data, the standard could be modified at a later date.
MRO's NERC Standards Review Subcommittee	No	While achievable, this will not come without effort and does not necessarily improve the reliability of the BES commensurate with the compliance burden.

Organization	Yes or No	Question 5 Comment
Arizona Public Service Company	No	FERC Order required the list to be made available for review to users, owners and operators of the Bulk-Power System upon request. Requirement 4 does not include the "request" requirement, implying that the Registered Entity must provide the list without a request. Further, the requirement does not specify what the Regional Entity will do with the list once it is provided.
TSGT System Planning Group	No	FERC Order No. 733 requires the settings be provided upon request and no initial or periodic submittal is required.
Kansas City Power & Light	No	The proposed R4 exceeds the concerns of FERC in this matter. FERC directed a requirement to provide information upon request. The proposed R4 requires data submission without request of the parties with interest to the information. Recommend the SDT consider modifying this requirement to provide this information upon the request of appropriate operating parties. Do not agree that the Regional Entity be included as a recipient of the list of transmission facilities. By NERC definition, the Regional Entity is the Compliance Monitor and Enforcement Authority for the NERC Reliability Standards and is not an operating entity. It is inappropriate to include Regional Entities as an entity to provide this information outside of the audit process established by the NERC Rules of Procedure. By definition, in the NERC Reliability Terminology, the Regional Entity is a compliance enforcement agent and not an operating organization of the Bulk Power System, and, therefore, has no operating reason to obtain this information. See definition below: Regional Entity - The term 'regional entity' is defined in Section 215 of the Federal Power Act means an entity having enforcement authority pursuant to subsection (e)(4) [of Section 215]. A regional entity (RE) is an entity to which NERC has delegated enforcement authority through an agreement approved by FERC. There are eight RE's. The regional entities were formed by the eight North American regional reliability organizations to receive delegated authority and to carry out compliance monitoring and enforcement activities. The regional entities monitor compliance with the standards and impose enforcement actions when violations are identified.
Independent Electricity System Operator	No	The objective of R4 as written is unclear. We speculate that by requiring the TOs, GOs and DPs to provide the list (associated with R1, Section 12) to the REs, the ERO will collect the relevant information from all REs to facilitate provision of such information to owners, users and operators of the BES upon request. If this is the intent, we suggest to replace "REs" with "ERO" to make it a more direct and efficient way to provide the information needed to support the request for information process. The requirement as written does not conform with the results-based concept in that it does not clearly specify a reliability directive. Hence alternatively, we suggest removal of this requirement altogether since the directive asks the ERO to document, subject to audit by the Commission, and to make available for review to users, owners and operators of the Bulk-Power System, by request, a list of those facilities. This can be dealt with outside of the standard process, for example, through RoP 1600.

Organization	Yes or No	Question 5 Comment
Long Island Power Authority	No	FERC order 733 p224 requires that the list of facilities that have protective relays set pursuant to R1.12 of anticipated overload be made available to users, owners, and operators of the BPS. However, the proposed revision to R4 requires the list to be made available to Regional Entity only. Please clarify. Also, FERC order uses the term “by request” which is missing from the proposed revision.
American Transmission Company	Yes	While achievable, this will not come without effort and does not necessarily improve the reliability of the BES commensurate with the compliance burden.
Pepco Holdings, Inc - Affiliates	Yes	
FirstEnergy	Yes	
Dominion Electric Market Policy	Yes	
E.ON U.S. LLC	Yes	
PacifiCorp	Yes	
Southern Company	Yes	
NV Energy	Yes	
NPPD	Yes	
Consumers Energy	Yes	
Idaho Power - System Protection	Yes	
ComEd	Yes	
Manitoba Hydro	Yes	
ISO New England Inc.	Yes	

Organization	Yes or No	Question 5 Comment
American Electric Power	Yes	
ITC Holdings	Yes	
	Yes	
Xcel Energy	Yes	
Duke Energy	Yes	Paragraph 224 addresses R1.12, requiring documentation and making available a list of facilities that have protective relays set pursuant to R1.12. Although Order 733 was silent on R1.13, should the new R4 not also apply to R1.13?
Wisconsin Electric		No comment

6. **Requirement R5 and part 5.1 (previously Requirement R3 and part 3.1) have been modified to establish the framework to address the directive in Paragraph 69 of Order no. 733, although the criteria itself (which will be Attachment B) is still being developed. Do you agree that this is an acceptable and effective method of meeting this directive considering that Requirement R5 is establishing the construct to insert the criteria at a future time in the form of Attachment B? If not, please explain.**

#### **Summary Consideration:**

A majority of commenters do not believe, or were unable to determine whether, the construct established in Requirement R5 is an acceptable and effective method of meeting this directive. Almost all commenters, regardless of whether they responded “Yes” or “No,” indicated their responses are conditional pending review of the criteria. The criteria that Planning Coordinators will use to determine which facilities must comply with PRC-023 were posted on September 23 for a 20-day informal comment period. The SDT has reviewed Requirement R5 and the criteria in Attachment B and has made conforming changes to ensure no conflicts exist. The full standard with Attachment B will be posted for a 45-day formal comment period.

One commenter disagreed with the approach in Requirement R5, part R5.1, noting there are a variety of differing, and often complex, operating conditions that dictate the need for transmission facilities. The commenter observed it is not necessary to dictate additional criteria because the TPL standards already require extensive studies of the transmission system. The SDT believes the proposed criteria defining the test Planning Coordinators will use to determine which facilities must comply with PRC-023 will address the commenters concerns. The proposed criteria are consistent with the simulations and assessments required by the TPL Reliability Standards and allow the Planning Coordinators to utilize those assessments as directed in Order No. 733.

One commenter noted that the SDT needs to work closely with the Reliability Coordination SDT (Project 2006-06) which is tasked with defining critical facilities or indentifying criteria for developing a list of critical facilities. The commenter disagreed with use of the phrase “facilities that are critical” in this requirement and cautioned that a requirement to create a list of critical facilities should not be addressed in this standard. The SDT notes that although the phrase “critical to reliability of bulk electric system” appears in the approved PRC-023-1 and is used in Order No. 733, the SDT recognizes that use of the same or similar terms in multiple standards will result in confusion. Use of the phrase “critical to reliability of the Bulk Electric System” in PRC-023 is intended to have meaning specific to the issue of relay loadability; specifically to identify facilities, that if they trip due to relay loadability following an initiating event, may contribute to undesirable system performance similar to what occurred during the August 2003 blackout. The SDT has modified the standard to replace the phrase “critical to the reliability of the bulk electric system” with “that must comply with this standard.” The SDT believes this will avoid potential confusion and that reliability will be adequately addressed because the criteria in Attachment B identify all facilities that must be subject to this standard to maintain reliability of the Bulk Electric System.

Some commenters noted that Requirement R5, Part 5.3 should require that the Planning Coordinator provide its list of facilities to all Transmission Owners, Generator Owners, and Distribution Providers within its area; not only the entities with facilities on the list. The SDT believes this is consistent with the intent of the requirement and has modified the standard accordingly to make this requirement explicit.

One commenter noted that Requirement R5, Part 5.1 is unnecessary since the process to use the criteria in Attachment B would almost certainly be to simply apply the criteria and that requiring documentation of such a process will result in increased paperwork and additional preparation for an audit without a reliability benefit. The SDT agrees that this part of Requirement R5 is unnecessary and has removed it from the Standard.



Several commenters requested modifications that are outside the scope of the SAR for this project.

- Two commenters indicated Requirement R5 should include wording that limits the scope of the transmission facilities to be evaluated to only those that can be tripped by the relay settings subject to Requirement R1 and that the SDT should add a requirement that the Transmission Owners, Generator Owners, and Distribution Providers provide the Planning Coordinators with a list of such transmission facilities. The SDT believes that since the existing Requirement R3 does not restrict the facilities which the Planning Coordinator must consider, the proposed modifications are outside the scope of the SAR for this project. The SDT further believes that transmission facilities that have no phase protective relays subject to tripping on load are sufficiently uncommon that the proposed requirement would place a significant burden on Transmission Owners, Generator Owners, and Distribution Providers while providing limited benefit to the Planning Coordinators.
- Two commenters believe the standard should not be applicable to Distribution Providers. The SDT believes that since the approved PRC-023-1 includes Distribution Providers, the proposal to exclude Distribution Providers is outside the scope of the SAR for this project. However, the SDT further believes it is possible for a Distribution Provider to own a relay that protects a transmission facility, even if the Distribution Provider does not own the protected facility.
- One commenter observed there is much confusion about the registration of Planning Coordinators and suggests that while the Order proposes the Planning Coordinator perform this test, it could be assigned to the Regional Entity or the Reliability Coordinator (as in the SPCTF recommendation) and achieve the same result. The SDT notes the approved PRC-023-1 already assigns the Planning Coordinator with the requirement to determine which facilities must comply with PRC-023. The SDT believes there is no reason to revisit this issue.

One commenter believes it is not appropriate to modify Requirement R5, part 5.3 to include the Regional Entity as a recipient of the list of transmission facilities because the Regional Entity is the Compliance Monitor and Enforcement Authority for the NERC Reliability Standards and is not an operating entity. The SDT believes the role of the Regional Entity in compliance enforcement does not preclude a Reliability Standard from including Regional Entities as the recipients of data. The SDT further believes that providing the Regional Entity with the list of transmission facilities subject to Requirement R1 is the most direct way to address the Commission’s objective to aid in the overall coordination of planning and operational studies among Planning Coordinators, Transmission Owners, Generator Owners, Distribution Providers, and Regional Entities.

Two commenters believe the criteria in Attachment B along with any necessary modifications to the associated requirement should be developed by a full drafting team. The Relay Loadability Standard Drafting Team that developed PRC-023-1 has been reconvened to address the directed modifications to the standard. The criteria that Planning Coordinators will use to determine which facilities must comply with PRC-023 were developed with the assistance of a “Blue Ribbon Panel” comprised of members from each region who are Subject Matter Experts in the area of Transmission Planning. Order No. 733 directs that the criteria in PRC-023 must include or be consistent with the system simulations and assessments that are required by the TPL Reliability Standards, and input from the Blue Ribbon Panel provides additional expertise necessary to develop the directed modifications.

Organization	Yes or No	Question 6 Comment
Northeast Power Coordinating Council	No	Requirement R5 states that the Planning Coordinator will determine which facilities below 200kV are critical to the reliability of the Bulk Electric System by applying criteria defined in Attachment B, which is to be developed. Therefore, respondents cannot comment on Attachment B. Respondents reserve the right to

Organization	Yes or No	Question 6 Comment
		comment when Attachment B is available for review. Because the document has been presented to the industry without Attachment B, how will Attachment B be presented to the industry? Regarding sub-requirement 5.3, it must be revised to clarify that the Planning Coordinator will provide the list of facilities subject to the Standard to all of the TOs, GOs, and DPs registered in its footprint, not just to those entities that have facilities on the list. 5.2 refers to "Part 1". As commented on previously in Question 5 and elsewhere, Part or Sub-requirement should be used for consistency.
Bonneville Power Administration	No	Requirement R5 is okay, but Part 5.1 adds an additional and useless extra burden to the applicable entities. The process that the Planning Coordinator is required by this part to have would almost certainly be to simply apply the criteria in Attachment B to lines and transformers operated below 200kV to determine if they are critical to the BES. Requiring documentation for such a trivial process results in increased paper work, additional preparation for an audit, and is a waste of everyone's time. We suggest deleting Part 5.1.
IRC Standards Review Committee	No	We disagree with modifying the requirement until the criteria is identified. Modifying the requirement now presumes the criteria will have no impact to the requirement. Contrarily, we believe that the criteria may cause some change to the requirement as well. The criteria in Attachment B along with any necessary modifications to the associated requirement should be developed by a full standards drafting team. Only the full standards drafting team could identify equally effective alternatives to the Commission's directives as they have made clear they allow in this Order and many others.
MRO's NERC Standards Review Subcommittee	No	As noted in Q1 above, a response would be conditional and depend on whether the criteria that will be established within Attachment B (see R5.1) are reasonable and apply to properly qualified facilities below 200 kV. In addition, the R5 requirement should include wording that limits the scope of the transmission facilities (line and transformer circuits) to be evaluated to only those transmission facilities that can be tripped by the relay settings subject to requirement R1. Requirement R5 should also qualify that only the transmission facilities that are "known" to be associated with the relay settings subject to requirement R1 need to be evaluated. If the SDT wants to better assure that the Planning Coordinator knows about all of the pertinent transmission facilities, then they should add a requirement that obligates Transmission Owners, Generator Owners, and Distribution Providers to provide the Planning Coordinator with a list of the transmission facilities that are associated with the relay setting subject to requirement R1.
E.ON U.S. LLC	No	See comments for item #1.
Transmission Access Policy Study Group	No	The proposed method of identifying facilities to which the standard will apply may be reasonable, though we cannot comment definitively until a draft of Attachment B is available. The standard should not be applicable to DPs, however. TAPS has been unable to find or think of an example in which a DP would have a load-

Organization	Yes or No	Question 6 Comment
		responsive transmission phase protection system, aside from a DP that is also a TO and has such a phase protection system because of its TO function. There is thus no reason to include DPs as potentially applicable entities. If the SDT retains DPs on the list of potentially applicable entities, it should at minimum clarify Requirement R5.3 to state that the Planning Coordinator will provide the list of facilities subject to the standard to all of the TOs, GOs and DPs registered in its footprint, not just to the entities who have facilities on the list. It is important that DPs who do not have facilities on the list have documentation from the Planning Coordinator demonstrating that fact.
American Transmission Company	No	As noted in Q1 above, an affirmative response would be conditional and depend on whether the criteria that will be established within Attachment B (see R5.1) are reasonable and apply to properly qualified facilities below 200 kV. In addition, the R5 requirement should include wording that limits the scope of the transmission facilities (line and transformer circuits) to be evaluated to only those transmission facilities that can be tripped by the relay settings subject to requirement R1. Requirement R5 should also qualify that only the transmission facilities that are “known” to be associated with the relay settings subject to requirement R1 need to be evaluated. If the SDT wants to better assure that the Planning Coordinator knows about all of the pertinent transmission facilities, then they should add a requirement that obligates Transmission Owners, Generator Owners, and Distribution Providers to provide the Planning Coordinator with a list of the transmission facilities that are associated with the relay setting subject to requirement R1.
TSGT System Planning Group	No	While we agree that the purpose of Requirement R5 is beneficial, there is much confusion about registration and responsibilities of Planning Coordinators. Though the FERC order proposes that planning coordinators perform the test developed herein, there is also flexibility in how NERC can achieve the same result. We believe that the Regional Entity (or the Reliability Coordinator, as was included in the System Protection and Control Task Force recommendation) should be the responsible functional entity for determining which elements operated at less than 200 kV need to meet Requirement R1. The Region was responsible for determining operationally significant facilities during the “Beyond Zone 3” process.
NV Energy	No	This approach is not yet an acceptable and effective method of meeting the directive of paragraph 69. Whether it becomes an acceptable and effective method of meeting the directive will depend on the content of Attachment B. I’ll reserve specific judgment and concerns until Attachment B is available for comment.
NPPD	No	Attachment B has not even been developed.
Idaho Power - System Protection	No	It is not acceptable or effective until Attachment B is completed and available for review.
Kansas City Power & Light	No	Do not agree with the approach in R5 and R5.1. This proposes to establish the criteria by which Reliability

Organization	Yes or No	Question 6 Comment
		<p>Coordinators will determine facilities critical to the reliability of the BES. There are a variety of differing, and often complex, operating conditions that dictate the need for transmission facilities. The TPL standards require extensive studies of the transmission system be performed under steady state and dynamic conditions to understand and identify sensitive areas of the transmission system and enable Reliability Coordinators to identify flowgates in their respective regions. In light of the Reliability Coordinators awareness of transmission sensitivities through these studies, it seems unnecessary to dictate to the Reliability Coordinators additional criteria. In addition, in R5.3, do not agree that the Regional Entity be included as a recipient of the list of transmission facilities. By NERC definition, the Regional Entity is the Compliance Monitor and Enforcement Authority for the NERC Reliability Standards and is not an operating entity. It is inappropriate to include Regional Entities as an entity to provide this information outside of the audit process established by the NERC Rules of Procedure. By definition, in the NERC Reliability Terminology, the Regional Entity is a compliance enforcement agent and not an operating organization of the Bulk Power System, and, therefore, has no operating reason to obtain this information. See definition below: Regional Entity - The term 'regional entity' is defined in Section 215 of the Federal Power Act means an entity having enforcement authority pursuant to subsection (e)(4) [of Section 215]. A regional entity (RE) is an entity to which NERC has delegated enforcement authority through an agreement approved by FERC. There are eight RE's. The regional entities were formed by the eight North American regional reliability organizations to receive delegated authority and to carry out compliance monitoring and enforcement activities. The regional entities monitor compliance with the standards and impose enforcement actions when violations are identified.</p>
Independent Electricity System Operator	No	We are unable to assess its acceptability and effectiveness until Attachment B is developed.
Utility Services	No	<p>The proposed method of identifying facilities to which the standard will apply may be reasonable, though we cannot comment definitively until a draft of Attachment B is available. The standard should not be applicable to DPs, however. We have been unable to find or think of an example in which a DP would have a load-responsive transmission phase protection system, aside from a DP that is also a TO and has such a phase protection system because of its TO function. There is thus no reason to include DPs as potentially applicable entities. If the SDT retains DPs on the list of potentially applicable entities, it should at minimum clarify Requirement R5.3 to state that the Planning Coordinator will provide the list of facilities subject to the standard to all of the TOs, GOs and DPs registered in its footprint, not just to the entities who have facilities on the list. It is important that DPs who do not have facilities on the list have documentation from the Planning Coordinator demonstrating that fact.</p>
Long Island Power Authority	No	LIPA understands the drafting team's rationale, however, believes that the proposed method in Attachment B

Organization	Yes or No	Question 6 Comment
		should be developed before providing comments.
Ameren	No	See our response to Question 1
American Electric Power	No	Please refer to our comment under question number 1. AEP reserves the right to provide additional comments once Attachment B has been drafted and supplied for industry review.
ERCOT ISO	No	ERCOT ISO respectfully asserts that the changes in this standard need more thorough discussion. This standard is incomplete without the Attachment B and the intent of the requirements is not explicitly clear. A standard drafting team (not a SAR SDT) needs to develop Attachment B through discussion of the entire process that will meet Order 733 directives. Attachment B is a critical component needed to assess R5 and provide further feedback. Requirement 5 needs to be reworded for clarity. The standard drafting team assigned to this project needs to work closely with the Reliability Coordination SDT (Project 2006-06), which is tasked with defining critical facilities or identifying criteria for developing a list of critical facilities. ERCOT ISO disagrees with the use of the phrase 'facilities that are critical' in this requirement. A requirement to create a list of critical facilities should not be addressed in this standard.
Duke Energy	No	We don't have Attachment B yet, and the standard development timeline has the standard being submitted to FERC in March of 2011, which we believe is an unreasonable timeline.
Pepco Holdings, Inc - Affiliates	Yes	While philosophically we do not agree that this standard should apply to facilities below 100kV (i.e. facilities that are not defined as BES facilities) we believe that as long as a sound engineering methodology is developed and applied uniformly to identify those facilities critical to the reliability of the BES, then the revised wording is acceptable. Our response, however, is qualified based on being granted an opportunity to comment and vote on the methodology contained in Attachment B once it is developed.
FirstEnergy	Yes	Although we agree that R5 is the appropriate requirement to reference the criteria to be used, it is still to be determined if we agree with the criteria since it is still being developed.
Consumers Energy	Yes	We are concerned about the criteria still undergoing development, and will offer any relevant comments on that criteria when it is published.
Arizona Public Service Company	Yes	
Dominion Electric Market Policy	Yes	

Organization	Yes or No	Question 6 Comment
PacifiCorp	Yes	
Southern Company	Yes	
ComEd	Yes	
Manitoba Hydro	Yes	
ISO New England Inc.	Yes	
ITC Holdings	Yes	
	Yes	
Xcel Energy	Yes	
Wisconsin Electric		No comment

**7. Attachment A has been modified to address the directive in Paragraph 264 of Order no. 733. Do you agree that this is an acceptable and effective method of meeting this directive? If not, please explain.**

**Summary Consideration:**

Three-fourths of commenters believe the addition of section 1.6 in Attachment A is not an acceptable and effective method of meeting this directive. More than one-half of commenters believe that addressing the directive in the proposed manner will have a negative impact on reliability of the bulk electric system. The SDT agrees that addressing the directive in the manner proposed in the first posting will have the unintended consequence of impacting the dependability and security of certain protection systems. The SDT has revised the draft standard to address the following concerns noted by commenters.

- More than one-half of commenters noted that the proposed modification would require overcurrent fault detectors applied to supervise distance (impedance) elements to meet the relay loadability requirements which would have a detrimental impact on reliability. Setting these fault detectors to meet PRC-023 would restrict the ability of some distance elements to trip for end-of-zone faults, particularly on weak source systems. Eliminating the fault detector to avoid this concern would have the negative impact of making the protection system susceptible to undesired tripping during close-in faults on adjacent elements. Some commenters further noted that many microprocessor relays have inherent overcurrent supervision of impedance elements which cannot be disabled.
- Several commenters noted that the standard should apply to protective systems and not to individual components of protective systems and that compliance should be based on the ability of the protective system as a whole to meet the performance criteria established by the standard. Some commenters also noted that a clarification is required that “protective functions” applies only to those protective relay elements that would respond to non-fault or load conditions and could issue a direct trip.
- Some commenters noted their belief that the modification goes well beyond the Commission’s concern and they proposed alternatives they believe would be equally effective and efficient approaches to addressing the Commission’s reliability concerns.

In response to these concerns, in particular the negative impact on reliability associated with the proposed modification, the SDT has modified section 1.6 to include “1.6. Supervisory elements associated with current based communication assisted schemes where the scheme is capable of tripping for loss of communications.” The SDT also modified the second bulleted item in section 2.1 to add the clause, “except as noted in section 1.6 above.”

Some commenters expressed concern that the proposed modifications would require the overcurrent element in a switch-on-to-fault (SOTF) scheme to be subject to the relay loadability criteria, in conflict with the SPCTF technical paper that indicates there is no suggested loadability criterion if the voltage arming threshold is set low enough. Some commenters expressed concern that the proposed modification could negatively jeopardize reliability by resulting in an operational decision to open breakers upon loss-of-potential to a protection system. These commenters note that it would be preferable to leave the element in-service with fast tripping enabled for a fault until the loss-of-potential condition can be diagnosed and corrected. The SDT believes that the modifications to section 1.6 noted above remove the unintended consequence of the original modifications that could have required overcurrent functions in all SOTF schemes and overcurrent functions used to supervise distance elements to meet Requirement R1.

One commenter proposed that the requirement for setting supervising relays be 115 percent of the facility rating nearest to a 4-hour duration rather than the 150 percent threshold established for other phase protective relay settings that may limit transmission system loadability. The SDT believes that with the modifications to section 1.6 noted above the same setting requirements are appropriate for all protective functions listed under section 1 of Attachment A. The SDT believes this is appropriate and necessary to meet the reliability objective of this standard.

One commenter noted that this directive needs to be addressed by a full standard drafting team to adequately address this directive and identify equally effective alternatives to the Commission’s directives. Another commenter recommended that the NERC System Protection and Control Subcommittee (SPCS) be engaged to investigate this issue and produce a white paper or other document describing any unintended consequences of implementing the FERC directive. The Relay Loadability Standard Drafting Team that developed PRC-023-1 has been reconvened to address the directed modifications to the standard. The SDT believes that the issues identified in Order No. 733 can be addressed adequately by this SDT with industry stakeholder input through the NERC Standard Development Process. The NERC SPCS will be consulted to address the potential for unintended consequences associated with the proposed modifications to implementing the directives from Order No. 733.

Organization	Yes or No	Question 7 Comment
Pepco Holdings, Inc - Affiliates	No	<p>We do not agree with the proposed wording of Section 1.6 of Attachment A which makes the standard apply to “Protective functions that supervise operation of other protective functions in 1.1 through 1.5”. The standard should apply to “protective systems” not individual components of protective systems. Compliance should be based on the ability of the “protective system” as a whole to meet the performance criteria established by the standard. Delving into the details of individual scheme designs and supervising element operation goes well beyond the purpose and scope of this standard. In paragraph 251 of Order 733 the Commission “expressed concern that section 3.1 could be interpreted to exclude certain protection systems that use communications to compare current quantities and directions at both ends of a transmission line, such as pilot wire protection or current differential protection systems supervised by fault detector relays” and requested comment on “whether it should direct the ERO to modify section 3.1 to clarify that it does not exclude from the requirements of PRC-023-1 pilot wire protection or current differential protection systems supervised by fault detector relays.” The Commission reiterated again in paragraphs 266, 268, and 270 their concern with not including supervising elements associated with “current differential schemes” to prevent them for operating on loss of communications. That being said, the proposed revision to Attachment A to include supervising elements for all protective functions in 1.1 through 1.5 goes well beyond addressing the Commission’s concern. We believe the Commission’s concern could be addressed by simply modifying Attachment A by deleting proposed section 1.6 and adding a new section 1.5.5 “Line current differential schemes, including supervising overcurrent elements”. The SDT’s current proposed wording for Section 1.6 would require the overcurrent element in a switch-on-to-fault scheme to be subject to the loadability criteria. However, the NERC SPCTF in their June 7, 2006 technical paper “Switch-on-to-Fault Schemes in the Context</p>



Organization	Yes or No	Question 7 Comment
		<p>of Line Relay Loadability” indicated there is no suggested loadability criterion if the voltage arming threshold is set low enough. Similarly, fault detectors which supervise distance elements would be subject to the loadability standard. However, there are no criteria established on how to set these elements, particularly on weak source systems, or zone 3 applications, where in order to reliably detect faults at the end of the zone of protection may require setting the supervising fault detector below 150% of line rating. The NERC SPCTF in their June 7, 2006 technical paper “Methods to Increase Line Relay Loadability” provided recommendations to increase loadability of distance elements through various techniques, such as the use of load encroachment elements or blinders, but does not specifically address setting of supervising elements. In fact, at present, there is no reliability standard requiring the use of supervising elements, and some newer microprocessor relays do not even employ supervising fault detectors on their distance elements. FERC in their Order 733 stated “As with our other directives in this Final Rule, we do not prescribe this specific change as an exclusive solution to our reliability concerns regarding the exclusion of supervising relay elements. As we have stated, the ERO can propose an alternative solution that it believes is an equally effective and efficient approach to addressing the Commission’s reliability concerns.”In summary, we believe that addressing the Commission’s concern regarding supervising elements on current differential schemes, as described in our second paragraph above, would satisfy the intent of Order 733, while not imposing unnecessary additional restrictions on what has proven historically to be extremely reliable protection practices.</p>
PSEG Companies	No	<p>In attachment A was added a new requirement, item 1.6. We not agree with this. Sometimes these elements have to be set lower than the criteria. As long as the protection system as a whole does not trip the line, then that should meet the criteria. Individual elements that supervise tripping element should NOT be part of the standard.</p>
Bonneville Power Administration	No	<p>Here we have a situation where the standard is being compromised to satisfy FERC’s misunderstanding of what a supervising relay is. In Paragraph 266, FERC gives an example of how a line differential relay works in an attempt to demonstrate why supervisory elements must not operate for load, but instead they clearly demonstrate their misunderstanding of the details of differential relay operation and what a supervisory relay is. Modern differential relays will disable the differential function upon loss of communications. If an overcurrent element is present, it would be used for backup protection, not as a supervisory element. If an overcurrent element were used to supervise a differential element, the sensitivity of the differential relay would be lost and the result would be a simple overcurrent relay. FERC’s misunderstanding has resulted in the improper addition of supervisory relays in Attachment A, Section 1. Sometimes supervisory relays must be set below maximum loading to obtain the purpose they were intended for. For example, it is often necessary to set overcurrent supervision of distance relays below the maximum load current of the line so that they will operate for remote faults. This modification to Attachment A would prohibit that action and make it impossible to set the supervisory relays to comply with the standard and still provide adequate protection. The</p>

Organization	Yes or No	Question 7 Comment
		modification to Attachment A is unacceptable.
FirstEnergy	No	<p>FirstEnergy supports applying PRC-023 to certain supervising relays, such as overcurrent relays that are enabled only when another (usually communications based) scheme is out of service, or overcurrent relays that are ANDed with current differential elements that can trip by themselves if the communications path used by the current differential scheme is compromised. However, it is not clear that a 150% factor is the correct one to use in this case. Our understanding is that 150% is a combination of an error factor (widely utilized by industry) of 15% plus a 35% margin to approximate a 15 minute interval rating to give operators time to react to adverse system conditions. It is unclear that this extra 35% margin is needed for these supervising relays, when the reliability goal is to prevent relays being continuously picked-up. We recommend that the standard utilize a 115% margin (rating duration nearest 4 hours) for these types of supervising relays and that this would be adequate to meet the Commission's stated reliability concerns. However, there are several other types of schemes that utilize supervising relays where applying PRC-023 would be detrimental to the reliability of the bulk power system. One widely used case is the supervision of an impedance relay when there is no communications scheme involved. There are cases where an impedance element/relay which is set per PRC-023, correctly operates for a fault it is intended to see, but that the actual current value will be on the order of the line rating, which will result in the scheme not operating if the supervising relay is set as the commission proposes. The alternative for these types of schemes is to remove the supervision from the scheme, which will result in the scheme operating purely on the impedance element, which is exactly the reliability concern that the Commission is trying to address with this directive. However, many microprocessor relays have inherent overcurrent supervision of impedance elements which cannot be disabled, adding to the complexity of the issue. Since this is a fairly complex theoretical/technical issue, we recommend that the NERC System Protection and Control Subcommittee (SPCS) investigate this issue and produce a white paper or other document describing any unintended consequences of implementing the FERC directive. The work of the SPCS could also consider equally effective alternatives to meeting the Commission's directive.</p>
IRC Standards Review Committee	No	<p>We believe this directive needs to be addressed by a full standards drafting team to ensure the precise language is crafted to adequately address the directive. Furthermore, we believe only the full standards drafting team could identify equally effective alternatives to the Commission's directives as they have made clear they allow in this Order and many others.</p>
MRO's NERC Standards Review Subcommittee	No	<p>In Order 733, the Commission cites in footnote 186 (p. 161) the definitions of dependability and security, two components of reliability for protective relays. The Commission did not recognize that the two tend to be mutually exclusive. Raising dependability (making sure breakers trip during a fault) can sacrifice some degree of security (tripping more than is needed). Historically, protection engineers have been biased toward dependability to ensure the safety of people and equipment. The exclusions allow that to happen. These are contingency scenarios where protective schemes are compromised. For a second contingency, the</p>

Organization	Yes or No	Question 7 Comment
		dependability is at risk if fast tripping is not employed. By removing the exclusion, reliability could be negatively jeopardized. For example, an operational decision to open breakers will be needed for loss of potential. The corollary would be leaving the element in service with fast tripping enabled for a fault until the loss of potential condition can be diagnosed and corrected.
Dominion Electric Market Policy	No	Dominion disagrees with the directive to the ERO to revise section 1 to include supervising relays for example, the fault detectors that we have in electromechanical distance schemes. The impedance relays are set to meet Reliability Standard PRC-023-1 while the overcurrent fault detector does not trip the transmission line breaker(s) independently of the impedance relays. Simultaneously meeting full allowance of the line terminal emergency loading limit and providing adequate sensitivity for detecting line faults with this fault detector will simply not be achievable for many of our lines.
E.ON U.S. LLC	No	E.ON U.S. requests a clarification of “protective functions” such that it applies only to those protective relay elements that would respond to non-fault or load conditions, and could issue a direct trip, upon operation, during a loss of communication or loss of potential condition.
American Transmission Company	No	In Order 733, the Commission cites in footnote 186 (p. 161) the definitions of dependability and security, two components of reliability for protective relays. The Commission did not recognize that the two tend to be mutually exclusive. Raising dependability (making sure breakers trip during a fault) can sacrifice some degree of security (tripping more than is needed). Historically, protection engineers have been biased toward dependability to ensure the safety of people and equipment. The exclusions allow that to happen. These are contingency scenarios where protective schemes are compromised. For a second contingency, the dependability is at risk if fast tripping is not employed. By removing the exclusion, reliability could be negatively jeopardized. For example, an operational decision to open breakers will be needed for loss of potential. The corollary would be leaving the element in service with fast tripping enabled for a fault until the loss of potential condition can be diagnosed and corrected.
PacifiCorp	No	Paragraph No. 264 directs a revision to Section 1 of Attachment A in order to include supervising relay elements. This change as currently written requires further clarification to meet this directive. For example, a Distance element is commonly supervised by a phase overcurrent element (Fault detector). If this change suggests that the overcurrent element has to be set above maximum load, then PacifiCorp disagrees with the modification. The fault detector will not trip the line by itself; it operates to qualify the distance element assertion. It is our standard practice to set this element above load where possible, but without restricting the reach of the distance element. This means that if the fault current at the maximum reach of the distance element is below load, setting the fault detector above load will restrict the reach of the distance element- this would compromise the protection scheme. In microprocessor relays where Load encroachment is used this is even more critical. The Load encroachment function will prevent the distance element from operating in the

Organization	Yes or No	Question 7 Comment
		load region and a fault detector setting that is sensitive enough can be used safely without the need to set it above load current to enhance the distance element reach.
Southern Company	No	<p>The language that has been added to PRC-023 related to the inclusion of protection elements (fault detectors) supervising protection functions that are subject to the PRC-023-2 requirements is not appropriate and will likely decrease the reliability of the BES for the following reasons:- The tripping logic utilizing these elements is an AND function, it takes distance element AND the fault detector (FD) to trip. Since all distance elements meet the loadability criteria, it is not necessary to also ensure FD meet these requirements.- Setting FD above nominal load point would unnecessarily reduce sensitivity of distance element and in many cases eliminate the distance element's ability to protect the very system element it is designed and intended to protect- It would require very expensive communications based relay schemes to replicate this lost protection if it is even possible to do so; a long radial line is one instance where it would not be possible- Eliminating the FD would actually reduce Security and Dependability in electromechanical schemes- There is a whole generation of microprocessor based relays that it is not possible to eliminate the FD; to effectively take it out of service, one would have to set it to the most sensitive setting which would violate the loadability criteria- Relays at terminals with high SIR, a weak source system, and line with large conductors where the far end fault current may be smaller than maximum line current (similar to Exception 6 of the Relay Loadability Exceptions: Determination and Applications of Practical Relaying Loadability Ratings, Version 1.1 published November 2004 by the System Protection and Control Task Force of NERC)- Faults with low power factor could present a similar magnitude of line current as normal high power factor load currents</p>
NPPD	No	<p>Please remove Attachment A, R1.6. "Protective functions that supervise operation of other protection functions in 1.1 through 1.5.". If you do not remove R1.6 you must provide a detailed explanation of what supervise operation means and give examples. Utilities have thousands of relays that have imbedded fault detective supervision overcurrents for phase distance elements that are set at 0.5 amps or some similar value. This can not be changed. From your requirement these utilities would have to replace all of these relays or we would have to lower the Facility rating to 0.5 amp secondary/150%. You are also stating that if we have an external phase overcurrent fault detector that supervises a phase distance relay that this fault detector must now have to meet Requirement 1. This is an unacceptable requirement if this is your intent. You are putting the system at risk if this is your intent. We must set our relays to protect the line. We must also set fault detectors to pickup for all faults considering N-1 conditions at a minimum where the strongest source must be remove and the relays must still clear the fault. Please do not lose focus of the purpose: "Protective relay settings shall be set to reliably detect all fault conditions and protect the electrical network from these faults". If you have questions on my comments feel free to contact me. Steve Wadas, NPPD, 402 563 5917 Wk.</p>

Organization	Yes or No	Question 7 Comment
Consumers Energy	No	<p>The supervising elements addressed within this change may fundamentally be unable to be set in accordance with the requirements of PRC-023, while still permitting the Protection System to function properly for fault conditions. The supervising element is usually present to assure that a distance element does not operate inadvertently for close-in zero-voltage faults near the relay location in the non-trip direction, but does not, by itself, produce a trip. We appreciate that NERC must respond to this directive, but believe that the change, as expressed, will be detrimental to reliability.</p>
ComEd	No	<p>1) Certain relay elements may be thought to be “supervising relay elements”, when their function is specific and more limited. A very common example would be a phase overcurrent relay that is required to actuate along with a phase distance relay to cause a trip. In many applications, the phase overcurrent relays function is only to assure that the phase distance relay will not cause a trip when a line is taken out of service and no potential restraint is applied to the phase distance relay. Thus, loadability of the phase overcurrent relay is not a concern. Raising the level of the overcurrent element may negatively impact the fault detecting ability of the two relays. This is perhaps a limited function supervising relay element. It is complementary to the phase distance relay which provides the necessary loadability.</p> <p>2) Although we don’t employ out of step tripping, it would seem that the argument for the overcurrent element of an out of step tripping scheme would be the same as for the phase distance element.</p> <p>3) Are there supervisory elements for switch onto fault schemes that could limit loadability?</p> <p>4) In our experience, relays that supervise overcurrent relays are typically specifically designed to provide loadability in order to allow the overcurrent relay to provide greater sensitivity without worrying about its loadability. Thus this requirement would limit the use of such a scheme.</p> <p>5) FERC’s main example seems to refer to an old style of current differential relaying scheme that is likely not very widely applied. Most modern current differential schemes use digital communications and will not trip on loss of communications regardless of the settings of any elements that may be considered to be supervisory relay elements. The drafting team should consider modifying 1.6 of Attachment A to clarify and more specifically address the FERC concern. Three suggestions are as follows: 1) 1.6. Protective functions that supervise operation of other protective functions in 1.5. This is required for communications aided protection schemes in 1.5 only when those schemes require communication channel integrity to maintain scheme loadability. 2) 1.6. Protective functions that supervise operation of other protective functions in 1.2 through 1.5. This is required for communications aided protection schemes in 1.5 only when those schemes require communication channel integrity to maintain scheme loadability. 3) 1.6. Protective functions that supervise operation of other protective functions in 1.2 through 1.5.</p>
Manitoba Hydro	No	<p>Item 1.6 in Attachment A is not necessary. If the protection functions in 1.1 through 1.5 already meet all the</p>

Organization	Yes or No	Question 7 Comment
		loadability requirements, the facility would not trip under heavy load condition by the supervising protection element alone. The directive in paragraph 264 of Order 733 seems to deal with the supervising protection element on the current differential scheme only. It is still arguable whether it is better to allow tripping of the line or restrain from tripping during loss communication and heavy loading condition.
Wisconsin Electric	No	We strongly disagree with this change. Applying the loadability requirement to supervisory functions in protection system will have an extremely negative effect on BES reliability. With this change, protection systems will be less dependable, resulting in increased probability of a failure to detect a system fault. This change should not be implemented.
Long Island Power Authority	No	LIPA believes that the new wording in 1.6 Attachment A is unnecessary since the existing wording already complies with the FERC order p.264. Supervisory functions are already part of the protective functions 1.1 through 1.5. Also, this new wording will be subject to varied interpretation and create more confusion.
Ameren	No	In attachment A - 1.6 is not a tripping function - it's a supervisory function - it in itself does not trip which is the description of '1' therefore needs to be elsewhere if kept.
American Electric Power	No	AEP requests some clarifying information regarding what is envisioned for 1.6 of Attachment A.
ITC Holdings	No	It appears from the new 1.6 (Attachmnt A) that fault detectors must meet loadability requirements. These do not trip and must not be included in PRC023. We will not be able to adequately protect longer lines in weak areas with this requirement in place.
	No	Removal of exclusion 3.1 in Att. A, will lead to reduced reliability because an operational decision to open breakers will be needed for loss of potential conditions. The corollary would be leaving the element in service with fast tripping enabled for a fault until the loss of potential condition can be diagnosed and corrected.
South Carolina Electric and Gas	No	Item 1.6 of Attachment A needs to be clarified. If the intent is to include protective functions such as fault detectors then this could possibly lead to relay sensitivity problems when switching contingencies create weaker systems than normal and a line is faulted. It is unclear why supervisory functions are considered if the protective functions they supervise will operate in compliance with R1
Xcel Energy	No	Xcel Energy disagrees with the inclusion of the supervising functions in part 1.6 of Section 1 in Attachment A. Supervising functions in protection schemes provide security for non-power system fault events and are not the principal elements for scheme operation. Only principal elements should be considered in the requirements of the PRCâ€™23 standard.Functions such as overcurrent fault detectors provide security in the

Organization	Yes or No	Question 7 Comment
		<p>event of a failed potential source or blown secondary fusing. Fault detectors must be set below the minimum end-of-zone fault with a single system contingency in effect. It is common industry practice to set these functions at 60%–80% of these minimum fault levels and may necessitate a setting that is below the Facility Rating of a circuit. Increasing the setpoint of an overcurrent fault detector above the Facility Rating will limit the coverage of the protection system and may impact the system’s ability to protect the electrical network from Faults. An alternative is to limit the Facility Rating as allowed in Requirement R1.12. However limiting this Facility Rating places an arbitrary constraint on the circuit and is not justifiable for a non-principal function. Eliminating the fault detector is not possible in the case of some microprocessor-based relays and if it is possible, reduces the security of the protective scheme.</p>
Duke Energy	No	<p>Attachment A has added 1.6 stating “Protective functions that supervise operation of other protective functions” is included in the standard. We would argue that it is not reasonable to include overcurrent fault detectors used to supervise distance elements or breaker failure schemes. These relays provide security to the protection scheme, such as for loss of potential conditions, and do not trip on their own. If these relays would be set per the standard, it would render the schemes ineffective for many fault conditions. In the case of electromechanical schemes, the supervising relay could be removed from service which could make the protection scheme misoperate. In the case of microprocessor relays, the supervising relay is embedded in logic and can’t be removed.</p>
TSGT System Planning Group	Yes	<p>As we interpret the changes to Attachment A they are acceptable. However, there appears to be uncertainty about the intent of the drafting team. We interpret the change to 1.6, in conjunction with 2.1, to allow setting impedance relay fault detector supervisory elements at levels below load current levels. This understanding comes from the realization that the fault detector elements by themselves do not “trip with or without time delay, on load current,” a requirement described in 1. The fault detector elements can cause tripping on their own, but only for conditions of loss of potential or loss of communications, which are both excluded from the loadability requirements as stated in 2.1. If Tri-State’s interpretation of the intent of Attachment A, Sections 1, 1.6, and 2.1 is incorrect, then we do not agree that this is an acceptable and effective method of meeting this directive. There are many protection system locations in our system that require the fault detector supervision elements to be set below load current levels in order for backup impedance relays to operate securely in the event of loss of potential and to operate dependably for remote faults that inherently have low fault current magnitudes.</p>
Idaho Power - System Protection	Yes	<p>The order has been met, but there is significant concern about the inclusion of supervisory elements in protective systems. A supervisory element is not performing a tripping function. As stated in Attachment A “This standard includes any protective functions which could trip with or without time delay, on load current, including but not limited to:....”. Supervisory elements, used properly, do not trip for load current.</p>

Organization	Yes or No	Question 7 Comment
Northeast Power Coordinating Council	Yes	
Arizona Public Service Company	Yes	
NV Energy	Yes	
Kansas City Power & Light	Yes	
Independent Electricity System Operator	Yes	
ISO New England Inc.	Yes	



**8. Do you agree that the SDT has addressed the remaining directives: Paragraph 284 to remove the footnote and Paragraph 283 to modify the implementation plan for sub-100 kV facilities (by revising the Effective Date section of the standard)?**

**Summary Consideration:**

The SDT agrees with several commenters about the proposed language for Effective Dates and has changed the language to the following:

5.1. Requirement R1: the first day of the first calendar quarter after applicable regulatory approvals, except as noted below.

- 5.1.1 For the addition to Requirement R1, criterion 10, to set transformer fault protection relays and transmission line relays on transmission lines terminated only with a transformer such that the protection settings do not expose the transformer to fault level and duration that exceeds its mechanical withstand capability, the first day of the first calendar quarter 12 months after applicable regulatory approvals.
- 5.1.2 For supervisory elements as described in Attachment A, section 1.6, the first day of the first calendar quarter following 24 months after applicable regulatory approvals.

5.2. Requirements R2 and R3: the first day of the first calendar quarter after applicable regulatory approvals.

5.3. Requirements R4 and R5: the first day of the first calendar quarter following 24 months after applicable regulatory approvals.

5.4. Requirement R6: the first day of the first calendar quarter 18 months after applicable regulatory approvals.

5.5. Requirement R7: the first day of the first calendar quarter after applicable regulatory approvals.

One comment addressed the issue of a reliability standard superseding previous agreements between registered entities and NERC. The SDT believes that, by removing the footnote, the standard does not supersede previous agreements because the latest due date for mitigation of temporary exceptions under the Beyond Zone 3 review was December 31, 2008. Removal of the footnote has no bearing on previous agreements given that all temporary exceptions have expired.

To address the need for entities to meet the requirements of the standard for facilities identified by the Planning Coordinator in the future, the SDT added a new requirement (R7).

Organization	Yes or No	Question 8 Comment
Pepco Holdings, Inc - Affiliates	No	We agree with the removal of the footnote regarding temporary exceptions. However, there appears to be a contradiction between the effective dates for sub 200kV facilities noted in section 5.1.2 (39 months following regulatory approvals) and 5.1.3 (24 months after being notified by its Planning coordinator). If the planning coordinator takes the full 18 months to determine the R5 list (per effective date section 5.2) and the TO has 24 months after that to comply, that would be 42 months following regulatory approval, which is in conflict with the 39 month requirement in 5.1.2. Since the list of sub 200kV facilities may change from year to year, it

Organization	Yes or No	Question 8 Comment
		<p>would seem prudent to make the effective date for those facilities always tied to a defined interval following being notified by the Planning Coordinator and eliminate the 39 month requirement for sub 200kV facilities from 5.1.2. Also, since the Attachment B methodology has not yet been determined, it is unclear how many sub 200kV facilities may fall under these requirements. As such, one cannot yet determine if the proposed 24 months would be sufficient. We propose at least a 36 month interval until the methodology is finalized and the magnitude of the scope better defined. In addition, if supervising elements are included in the standard in some form, an implementation schedule (i.e. appropriate effective dates) need to be developed based on this significant increase in scope and number of facilities to be reviewed.</p>
Bonneville Power Administration		<p>5.1.2 and 5.1.3 both apply to the same systems and should be combined into one sub-requirement. Also, since the date of the applicable regulatory approval is now established, please consider replacing the cryptic phrase “at the beginning of the first calendar quarter 39 months following applicable regulatory approval” with an actual date.</p>
IRC Standards Review Committee	No	<p>While we agree removing the footnote is straight forward and addresses one Commission directive, we believe the other directives need to be addressed by a full standards drafting team to ensure the precise language is crafted to adequately address the directives. Furthermore, we believe only the full standards drafting team could identify equally effective alternatives to the Commission’s directives as they have made clear they allow in this Order and many others. In particular, we believe that only a full drafting team could adequately assess if any additional time will be needed to comply with the standard for sub-100 kV facilities particularly when we consider there are some outstanding issues including a regional entity’s critical facilities list identified in Question 1. Also, we are unable to assess if the two directives are fully addressed absent a proposed implementation plan.</p>
Kansas City Power & Light	No	<p>It is inappropriate for this standard to supersede any other agreements and the provisions of those agreements that have been established between NERC and Registered Entities. The footnote made it clear those agreements would continue to be honored. Recommend the SDT reinstate the principles established by the footnote directly into the Effective Dates section to recognize the authority of those agreements. Agree with the effective dates of 18 months after applicable approvals for R5 and for 24 months after notification by the Planning Coordinator of a new critical facility.</p>
Independent Electricity System Operator	No	<p>We are unable to comment on this in the absence of a proposed implementation plan.</p>
E.ON U.S. LLC	No	<p>Cannot assess the impact until Attachment B is developed and commented sections above are clarified.</p>

Organization	Yes or No	Question 8 Comment
Manitoba Hydro	No	Even though this version of the standard does seem to have addressed Paragraph 284 of Order 733, we still do not agree with the uniform effective date without taking into consideration how many critical circuits or equipment could be added for an individual utility.
American Electric Power	No	It is unclear how much time a TO, GO, or DP would have to implement the changes based on the results of the analysis by the Planning Coordinator. In addition, the Effective Date section is a one-time event upon regulatory approval. What are the on-going implementation expectations? There should be some allowed lead beyond initial implementation after facilities are identified by the Planning Coordinator.
ITC Holdings	No	The new effective dates for 5.1.2 will for the most part be ok. Some of these below 200 kV lines will have to be reconstructed to be able to have adequate protection and meet the required loadability. It will be difficult to do this in 39 months. We suggest a mitigation program be required for those lines that will be difficult to meet the 39 month deadline.
Duke Energy	No	Until we see the criteria for Attachment B, we can't agree that 39 months is sufficient time.
ISO New England Inc.	No	While we agree removing the footnote is straight forward and addresses one Commission directive. In particular, we believe that only a full drafting team could adequately assess if any additional time will be needed to comply with the standard for sub-100 kV facilities particularly when we consider there are some outstanding issues a regional entities critical facilities list identified in Question 1. Also, we are unable to assess if the two directives are fully addressed absent a proposed implementation plan.
Long Island Power Authority	No	
Northeast Power Coordinating Council	Yes	
FirstEnergy	Yes	
MRO's NERC Standards Review Subcommittee	Yes	
Dominion Electric Market Policy	Yes	
American Transmission	Yes	

Organization	Yes or No	Question 8 Comment
Company		
Southern Company	Yes	
TSGT System Planning Group	Yes	
NV Energy	Yes	
NPPD	Yes	
Consumers Energy	Yes	
Idaho Power - System Protection	Yes	
ComEd	Yes	
Ameren	Yes	
Xcel Energy	Yes	
Wisconsin Electric		No comment

**9. Do you agree that the scope of the proposed standards action addresses the directive or directives?**

**Summary Consideration:**

The SAR shows the directive from P. 162 as part of Phase I to be implemented by March 18, 2011. However, some commenters indicated this directive should be included in Phase III since it deals with the subject of relay operations due to power swings. The SDT reviewed the SAR and determined a modification to the SAR is unnecessary because the SDT already has considered “islanding” strategies that achieve the fundamental performance for all islands as part of Phase I, although following this consideration the SDT agrees islanding strategies are best addressed as part of the new standard that will be developed in Phase III of the project.

Several commenters indicated that the directive from P. 224 is missing from the detailed section of the SAR, but is included in the table in the back of the SAR. This was an error in the SAR and the SDT has added this directive to the detailed section of the SAR for Phase I. The new Requirement R5 will support collection of the data necessary for the ERO to address the directive. The ERO will provide the data upon request, but outside of PRC-023.

Organization	Yes or No	Question 9 Comment
FirstEnergy	No	i. The SAR shows the directive from P. 162 as part of Phase I to be implemented by March 18, 2011. However, this directive should be included in Phase III since it deals with the subject of relay operations due to power swings. ii. The directive from P. 224 is missing from the detailed section of the SAR, but is included in the table in the back of the SAR. iii. As mentioned in our response to Question 7, we do not agree with how the project is proposing to address the P. 264 directive.
<p><b>Response: The SDT reviewed the SAR and determined a modification to the SAR regarding P.162 is unnecessary because the SDT already has considered “islanding” strategies that achieve the fundamental performance for all islands as part of Phase I, although following this consideration the SDT agrees islanding strategies are best addressed as part of the new standard that will be developed in Phase III of the project.</b></p> <p><b>The reference to P.224 was omitted from the detailed section of the SAR by error. The SDT has added this directive to the detailed section of the SAR for Phase I. The new Requirement R5 will support collection of the data necessary for the ERO to address the directive. The ERO will provide the data upon request, but outside of PRC-023.</b></p> <p><b>Please see our response above to your comment regarding P.264</b></p>		
IRC Standards Review	No	We largely believe the scope will allow the drafting team to address the directives. However, we request that

Organization	Yes or No	Question 9 Comment
Committee		<p>the scope be modified to make clear that the drafting team may use equally effective alternatives to address the Commission’s directives per the Commission in this order and other orders such as Order 693. There is a discrepancy between the entities listed in the Applicability Section and those checked off in the SAR. The latter indicates that the SAR is also applicable to the Reliability Coordinator, which we do not believe is appropriate.</p>
<p><b>Response: The Standards Process Manual states that a Standard Authorization Request (SAR) is the form used to document the scope and reliability benefit of a proposed project for one or more new or modified standards or the benefit of retiring one or more approved standards. This SAR is specific to addressing regulatory directives in Order No. 733. The SAR should only contain the scope and not include how the directives will be met as it is understood that the directives may be met in an equally effective alternative.</b></p> <p><b>The SDT notes that the SAR contains a list of entities that could potentially be included in the standard, but it is not necessary that the SDT include each entity in the applicability section of the standard.</b></p>		
MRO's NERC Standards Review Subcommittee	No	It addresses the directives per the letter of the order; however, it is not necessarily improving reliability.
<p><b>Response: Thank you for your input.</b></p>		
E.ON U.S. LLC	No	See commented sections above. Also, the directive identified in Paragraph 224 was not included in the detailed description or highlighted in Attachment 1 of the SAR. However it was included in the proposed modifications as R4.
<p><b>Response: The reference to P.224 was omitted from the detailed section of the SAR by error. The SDT has added this directive to the detailed section of the SAR for Phase I. The new Requirement R5 will support collection of the data necessary for the ERO to address the directive. The ERO will provide the data upon request, but outside of PRC-023. Requirement R5 does not address the directive in P.224 directly as this is a directive to the ERO to provide data upon request. Since the data is subject to audit, the SDT interprets this to mean that the ERO must gather and have continuously available a list of facilities using Requirement R1 criterion 12. Requirement R5 ensures that the data is available.</b></p>		
TSGT System Planning Group	No	As stated in our earlier comments, we believe that some proposals exceed the directives. It is also not clear how p 162 was addressed in PRC-023-2 as indicated on SAR-3.
<p><b>Response: The SDT notes that this directive is not addressed in PRC-023-2. The SDT considered “islanding” strategies that achieve the fundamental performance for all islands as part of Phase I, although following this consideration the SDT agrees islanding strategies are best addressed as part of the new standard that will be developed in Phase III of the project.</b></p>		

Organization	Yes or No	Question 9 Comment
NPPD	No	
American Electric Power	No	Refer to our comment under question 1.
<b>Response: Please see our response above to your comment on Question 1.</b>		
Pepco Holdings, Inc - Affiliates	Yes	While the scope of the proposed standards action addresses the directive(s) outlined in FERC Order 733 we believe that there are two significant issues that need to be much more thoroughly investigated before being included. Those areas are the inclusion of supervising elements in the existing relay loadability standard and the development of any new standard that would “require the use of protective relay systems that can differentiate between faults and stable power swings and when necessary phase out protective relay systems that cannot meet this requirement.”
<p><b>Response: In response to industry concerns regarding supervisory elements, in particular the negative impact on reliability associated with the proposed modification, the SDT has modified section 1.6 to state: “1.6. Supervisory elements associated with current based communication assisted schemes where the scheme is capable of tripping for loss of communications.” The SDT also modified the second bulleted item in section 2.1 to add the clause, “except as noted in section 1.6 above.” The NERC SPCS will be consulted to address the potential for unintended consequences associated with the proposed modifications to implementing the directives from Order No. 733.</b></p> <p><b>The issues related to power swings will be addressed in Phase III of this project according to the SAR, and the NERC System Protection and Control Subcommittee (SPCS) and Transmission Issues Subcommittee (TIS) are jointly developing a paper, <i>Issues Related to Protective System Response to Power Swings</i>.</b></p>		
American Transmission Company	Yes	It addresses the directives per the letter of the order; however, it is not necessarily improving reliability.
<b>Response: Thank you for your input.</b>		
Kansas City Power & Light	Yes	Agree that the SDT has made revisions that attempted to address the FERC directives. Do not agree with all the proposals by the SDT as indicated by the comments regarding questions 1 through 8.
<b>Response: Please see our responses above to your comment on Questions 1 through 8.</b>		
Independent Electricity System Operator	Yes	As indicated in our comment submitted under Q1, there is a discrepancy between the entities listed in the Applicability Section and those checked off in the SAR. The latter indicates that the SAR is also applicable to the RC, which we do not believe is required.

Organization	Yes or No	Question 9 Comment
<p><b>Response: The SDT notes that the SAR contains a list of entities that could potentially be included in the standard, but it is not necessary that the SDT include each entity in the applicability section of the standard.</b></p>		
Northeast Power Coordinating Council	Yes	
Bonneville Power Administration	Yes	
Dominion Electric Market Policy	Yes	
Arizona Public Service Company	Yes	
PacifiCorp	Yes	
Southern Company	Yes	
NV Energy	Yes	
Consumers Energy	Yes	
Idaho Power - System Protection	Yes	
ComEd	Yes	
Manitoba Hydro	Yes	
ISO New England Inc.	Yes	
Long Island Power Authority	Yes	
ITC Holdings	Yes	
	Yes	



Organization	Yes or No	Question 9 Comment
Duke Energy	Yes	
Wisconsin Electric		No comment

**10. Can you identify an equally efficient and effective method of achieving the reliability intent of the directive or directives?**

**Summary Consideration:**

Many comments were offered regarding the directives in Paragraph 150 of Order 733 that NERC “develop a Reliability Standard that requires the use of protective relay systems that can differentiate between faults and stable power swings and, when necessary, phases out protective relay systems that cannot meet this requirement,” and suggested that this subject either needs to be addressed via modification to TPL-001 or that it needs further study. It is notable that this issue is to be addressed in Phase III of this project according to the SAR, and that the SPCS and TIS are jointly developing a paper, *Issues Related to Protective System Response to Power Swings*.

Many other commenters repeated comments that were offered in response to other questions.

Organization	Yes or No	Question 10 Comment
American Electric Power	No	Not at this time, but AEP would like to consider all viable options throughout the standard development process.
<b>Response: Thank you for your input.</b>		
FirstEnergy	No	Regarding the directive of Par. 264, since this is a fairly complex theoretical/technical issue, we recommend that the NERC System Protection and Control Subcommittee (SPCS) investigate this issue and produce a white paper or other document describing any unintended consequences of implementing the FERC directive. The work of the SPCS could also consider equally effective alternatives to meeting the Commission’s directive.
<b>Response: The NERC SPCS will be consulted to address the potential for unintended consequences associated with the proposed modifications to implementing the directives from Order No. 733.</b>		
IRC Standards Review Committee	No	We are not prepared at this time to offer equally efficient and effective alternatives. Rather, we believe this is the purpose for convening a full drafting team and that the drafting team should propose their alternatives.
<b>Response: The Relay Loadability Standard Drafting Team that developed PRC-023-1 has been reconvened to address the directed modifications to the standard. The SDT believes that the issues identified in Order No. 733 can be addressed adequately by this SDT with industry stakeholder input</b>		

Organization	Yes or No	Question 10 Comment
<b>through the NERC Standard Development Process.</b>		
Dominion Electric Market Policy	No	Since there is no question that asks if there are other concerns with this draft, I will add one here..... R2 should be modified to read "The Each Transmission Owner, Generator Owner, or and Distribution Provider that uses a circuit capability with the practical limitations described in Requirement R1, Settings1.6, R1.7, R1.8, R1.9, R1.12, or R1.13 shall use the calculated circuit capability as the Facility Rating of the circuit and shall forward this information to the Planning Coordinator, Transmission Operator, and Reliability Coordinator. The burden for acknowledging agreement or specifying reasons for disagreement should reside with the Planning Coordinator, Transmission Operator, and Reliability Coordinator. Suggest SDT develop additional requirements similar to those in FAC-008 @ R2 and R3.
<b>Response: This proposal is outside the scope of the SAR that is intended to limit the project to addressing the directives in Order No. 733. This suggestion could be made when the standard is reviewed during the required 5-year review of the standard.</b>		
ISO New England Inc.	No	We are not prepared at this time to offer equally efficient and effective alternatives. Rather, we believe this is the purpose for convening a full drafting team and that the drafting team should propose their alternatives.
<b>Response: The Relay Loadability Standard Drafting Team that developed PRC-023-1 has been reconvened to address the directed modifications to the standard. The SDT believes that the issues identified in Order No. 733 can be addressed adequately by this SDT with industry stakeholder input through the NERC Standard Development Process.</b>		
NV Energy	No	NERC's proposed Phase I, II, II process seems reasonable.
<b>Response: Thank you for your support.</b>		
ComEd	No	No, other than the comments provided for question 7.
<b>Response: Please see our responses above to your comment on Question 7.</b>		
Dominion Electric Market Policy	No	
PacifiCorp	No	
Southern Company	No	

Organization	Yes or No	Question 10 Comment
NPPD	No	
Idaho Power - System Protection	No	
Kansas City Power & Light	No	No other comments.
ITC Holdings	No	
	No	
Northeast Power Coordinating Council	No	
Duke Energy	No	
Bonneville Power Administration	No	
TSGT System Planning Group	Yes	We included specific proposals in our comments to questions 2, 4, 5, and 6.
<b>Response: Please see our responses above to your comment on Questions 2, 4, 5, and 6.</b>		
Manitoba Hydro	Yes	The effective date can be dependent upon how many critical circuits or equipment are identified for each individual company.
<b>Response: The SDT considered this possibility in developing effective dates for each requirement in the standard.</b>		
Consumers Energy	Yes	NERC should, again, oppose the FERC directive in paragraph 264, since, as explained above, this directive is both unnecessary and detrimental to reliability.
<b>Response: In response to industry concerns, in particular the negative impact on reliability associated with the proposed modification, the SDT has modified section 1.6 to state: “1.6. Supervisory elements associated with current based communication assisted schemes where the scheme is capable of tripping for loss of communications.” The SDT also modified the second bulleted item in section 2.1 to add the clause, “except as noted in section 1.6 above.”</b>		

Organization	Yes or No	Question 10 Comment
Long Island Power Authority	Yes	Involving industry working groups such as IEEE, EPRI, etc who have proven technical experts will also help in effectively achieving reliability.
<p><b>Response: The NERC System Protection and Control Subcommittee (SPCS) will be consulted to address the potential for unintended consequences associated with the proposed modifications to implementing the directives from Order No. 733.</b></p>		
Pepco Holdings, Inc - Affiliates	Yes	<p>Regarding the response of protective relay systems to stable power swings, Draft 5 of TPL-001-2 Requirement R4 (stability assessment) section 4.3.1 requires a contingency analysis be performed which includes “tripping of transmission lines and transformers where transient swings cause protection system operation based on generic or actual relay models.” Therefore the impact of power swings on relay operation is already addressed in TPL-001. If the tripping of a line is identified during this study phase the impact of the line trip is assessed to ensure the system meets the performance criteria identified in Table 1. If not, mitigating measures would be required, such as modifying that protection scheme to prevent its operation during a stable power swing. However, this would be done on a case by case basis when identified. This seems a much more prudent approach than to require “all protection systems be modified to prevent operation during stable power swings.” That would be similar to requiring the re-conductoring all lines so that they could never experience an overload. Also, Appendix F of the “PJM Relay Subcommittee Protective Relaying Philosophy and Design Standards” employs a methodology to address relay response during power swings by calculating a transient load limit for the relay instead of just the steady state limit identified in PRC-023. The relay loadability is evaluated at the maximum projection along the +R axis (the most susceptible point for swings to enter) rather than at a 30 degree load angle. Various multiplying factors are used to account for the relay operating time delay. This methodology of calculating relay transient loadability limits, which was developed by the PJM Relay Subcommittee over 30 years ago, has worked extremely well in eliminating relay operations during stable power swings. In summary, there are other methods to evaluate and improve the performance of protection systems during power swings short of hardware replacements. All options should be evaluated</p>
<p><b>Response: The issues related to power swings will be addressed in Phase III of this project according to the SAR, and the NERC System Protection and Control Subcommittee (SPCS) and Transmission Issues Subcommittee (TIS) are jointly developing a paper, <i>Issues Related to Protective System Response to Power Swings</i>.</b></p>		
MRO's NERC Standards Review Subcommittee	Yes	On the topic of ‘adding in’ - listing and evaluating the transmission facilities below 200 kV, we propose the inclusion of qualifications that prevent the consideration and evaluation of irrelevant facilities (e.g. facilities that are not tripped by the applicable relay settings).
<p><b>Response: The SDT believes the proposed criteria in Attachment B defining the test Planning Coordinators will use to determine which facilities must</b></p>		

Organization	Yes or No	Question 10 Comment
<p><b>comply with PRC-023 will address the commenters concerns.</b></p>		
<p>American Transmission Company</p>	<p>Yes</p>	<p>On the topic of 'adding in' - listing and evaluating the transmission facilities below 200 kV, we propose the inclusion of qualifications that prevent the consideration and evaluation of irrelevant facilities (e.g. facilities that are not tripped by the applicable relay settings).</p>
<p><b>Response: The SDT believes the proposed criteria in Attachment B defining the test Planning Coordinators will use to determine which facilities must comply with PRC-023 will address the commenters concerns.</b></p>		
<p>ERCOT ISO</p>		<p>ERCOT ISO thinks a standard drafting team can evaluate the Order 733 directives, work in conjunction with other Standard Drafting Teams already addressing some aspects of critical facilities, may be able to more succinctly arrive at an equally efficient and effective method of achieving the intent of the directive(s). The coordination between teams is vital to avoid confusion and possible overlap.</p>
<p><b>Response: The SDT has addressed the specific comment regarding coordination with the Reliability Coordination SDT (Project 2006-06) by modifying the standard to replace the phrase "critical to the reliability of the bulk electric system" with "that must comply with this standard." The SDT believes that the directed modifications to PRC-023-1 contained in Order No. 733 are unique to this standard and do not require coordination with other SDTs.</b></p>		
<p>E.ON U.S. LLC</p>	<p>Yes</p>	
<p>Wisconsin Electric</p>		<p>No comment</p>

**11. Do you agree with the scope of the proposed standards action?**

**Summary Consideration:**

Several commenters indicated that they do not agree with the scope of the proposed standards action based on the technical comments submitted against many of the proposed actions submitted in response to the original FERC NOPR on PRC-023. In response, the SDT indicated that FERC considered the comments submitted to the original FERC NOPR on PRC-023 and issued directives in Order No. 733 that the SDT must address.

Several commenters indicated that the scope of the SAR should be modified to make clear that the drafting team may use equally effective alternatives to address the Commission's directives per the Commission in this order and other orders such as Order 693. In response the SDT cited the Standards Process Manual. The Standards Process Manual states that a Standard Authorization Request (SAR) is the form used to document the scope and reliability benefit of a proposed project for one or more new or modified standards or the benefit of retiring one or more approved standards. This SAR is specific to addressing regulatory directives in Order No. 733. The SAR should only contain the scope and not include how the directives will be met as it is understood that the directives may be met in an equally effective alternative.

Many comments received indicated that the proposed modifications to PRC-023 reach beyond the directives without specifying which particular modifications are problematic. The SDT worked carefully to not go beyond the directives.

A commenter indicated that the scope should address apparent conflicts in timing of requirements posed by the standard. A newly proposed implementation plan will be proposed in the formal posting of PRC-023 that allows transition time for entities to become compliant with the modified requirements. The SDT agrees that a revised implementation plan is necessary and will post it for review by the industry during the next posting of the standard.

Some commenters suggested that several parts of the standard go too far (Appendix A R1.10) and will require documenting faults and clearing times to prove the fault duty of transformer connections. They also suggested the requirements to deal with out of step blocking relays should go in phase 3 and not in this standard. The SDT believes that evidence such as coordination curves or summaries of calculations are sufficient to demonstrate that relays set per criterion 10 do not expose the transformer to fault levels and durations beyond those indicated in the standard. The potential for out-of-step blocking protection elements to assert due to system load conditions already is addressed in PRC-023-1. Moving this subject from Attachment A to an explicit requirement in PRC-023-2 does not alter the requirement that already exists for Transmission Owners, Generator Owners, and Planning Coordinators. The SDT also notes that operation of out-of-step blocking elements due to system load conditions is outside the scope of Phase III of this project which is to address the directive regarding protection system operation during power swings.

Some commenters noted believe that removal of exclusion 3.1 in Att. A, will lead to reduced reliability because an operational decision to open breakers will be needed for loss of potential conditions. The SDT has modified section 1.6 in response to concerns that applying the standard to elements such as fault detectors that supervise directional distance elements could have

a negative impact on reliability. The SDT has modified section 1.6 to include “Supervisory elements associated with current based communication assisted schemes where the scheme is capable of tripping for loss of communications.” The SDT also modified the second bulleted item in section 2.1 (formerly 3.1) to add the clause, “except as noted in section 1.6 above.”

Organization	Yes or No	Question 11 Comment
Pepco Holdings, Inc - Affiliates	No	We do not agree with the scope of the proposed standards action for numerous reasons. The documented responses to the original FERC NOPR on PRC-023 from numerous sources, including NERC and EEI, together make a rather convincing technical argument against many of these proposed actions. We support these technical arguments, which for the sake of brevity will not be repeated here. In addition, we have provided comments and objections on specific portions of the proposed standards action in our responses to questions 1 through 10 above.
<b>Response: FERC considered the comments submitted to the original FERC NOPR on PRC-023 and issued directives in Order No. 733 that the SDT must address.</b>		
MRO's NERC Standards Review Subcommittee	No	We agree that the topics of generator relay loadability and power swing protective relaying should be referred to in other separate standards. While we acknowledge that it is in everyone’s best interest to respond to the FERC directives, there are numerous technical flaws that need to be resolved in their request. Forming a team and spending considerable resources will not gain industry acceptance to these directives.
<b>Response: FERC considered the comments submitted to the original FERC NOPR on PRC-023 and issued directives in Order No. 733 that the SDT must address.</b>		
American Transmission Company	No	We agree that the topics of generator relay loadability and power swing protective relaying should be referred to in other separate standards. While we acknowledge that it is in everyone’s best interest to respond to the FERC directives, there are numerous technical flaws that need to be resolved in their request. Forming a team and spending considerable resources will not gain industry acceptance to these directives.
<b>Response: FERC considered the comments submitted to the original FERC NOPR on PRC-023 and issued directives in Order No. 733 that the SDT must address.</b>		
PacifiCorp	No	It is very difficult to comment on test parameters that have not been determined.
<b>Response: The criteria that Planning Coordinators will use to determine which facilities must comply with PRC-023 were posted on September 23 for a</b>		



Organization	Yes or No	Question 11 Comment
<p><b>20-day informal comment period. The SDT has reviewed Requirement R5 and the criteria in Attachment B and has made conforming changes to ensure no conflicts exist. The full standard with Attachment B will be posted for a 45-day formal comment period.</b></p>		
Kansas City Power & Light	No	Do not agree with all the proposals by the SDT as indicated by the comments regarding questions 1 through 8.
<p><b>Response: Thank you for your comments. Please see the summary considerations above.</b></p>		
ISO New England Inc.	No	<p>We largely believe the scope will allow the drafting team to address the directives. However, we request that the scope be modified to make clear that the drafting may use equally effective alternatives to address the Commission’s directives per the Commission in this order and other orders such as Order 693.</p> <p><b>Response: The Standards Process Manual states that a Standard Authorization Request (SAR) is the form used to document the scope and reliability benefit of a proposed project for one or more new or modified standards or the benefit of retiring one or more approved standards. This SAR is specific to addressing regulatory directives in Order No. 733. The SAR should only contain the scope and not include how the directives will be met as it is understood that the directives may be met in an equally effective alternative.</b></p> <p>The scope should address apparent conflicts in the timing of requirements posed by the standard. It is our understanding that, based on the final date afforded NERC to develop the criteria for the determination of sub-200 kV facilities, a newly proposed implementation plan will be offered to allow the Planning Coordinators an appropriate time frame to apply the criteria to determine the “critical” facilities below 200 kV. The implementation plan should cause the effective date for circuits described in 4.1.2 and 4.1.4 to be changed from “39 months following applicable regulatory approvals” to a date linked to the Planning Coordinators schedule to provide a list to its TOs, GOs and DPs.</p> <p><b>Response: The SDT modified the implementation schedule for those requirements that the SDT has modified to address a FERC directive in Order No. 733. In addition, the SDT added a requirement, now Requirement R7, that requires the Transmission Owners, Generator Owners, and Distribution Providers to implement Requirement R1, Requirement R2, Requirement R3, and Requirement R4, and Requirement R5 for each facility that is added to the Planning Coordinator’s list of facilities that must comply with this standard pursuant to Requirement R6, Part 6.12 by the later of the first day of the second calendar quarter after 24 months following notification by the Planning Coordinator of a facility’s inclusion on such a list, or the first day of the first calendar quarter of the year in which criterion B6 first applies.</b></p>
Duke Energy	No	<p>o The SAR states that Paragraph 162 is part of Phase I, but the new standard addressing stable power</p>

Organization	Yes or No	Question 11 Comment
		swings is Phase III.
<p><b>Response:</b> The SAR shows the directive from P. 162 as part of Phase I to be implemented by March 18, 2011. However, this directive should be included in Phase III since it deals with the subject of relay operations due to power swings. The SDT reviewed the SAR and determined to leave this in Phase I because the directive says to consider “islanding” strategies that achieve the fundamental performance for all islands in developing the new Reliability Standard addressing stable power swings but agrees that a new standard will be developed for this in Phase III of the project.</p>		
ITC Holdings	No	Several parts of the standard go too far (Appendix A R1.10) and will require us to document faults and clearing times to prove the fault duty of transformer connections. Also the requirements to deal with out of step blocking relays should go in phase 3 and not in this standard.
<p><b>Response:</b> This is part of the existing, approved standard and the SDT cannot change this part of the standard since it is not associated with a directive in Order No. 733. The SDT removed out-of-step blocking from Requirement R1. The requirement pertaining to evaluation of out-of-step blocking protection has been moved to a separate requirement (now Requirement R2) to more clearly delineate this requirement from assessment of relay loadability of phase protective relays. Phase III of this project will address protective relays operating unnecessarily due to stable power swings and is not intended to address out of step blocking relays.</p>		
	No	Removal of exclusion 3.1 in Att. A, will lead to reduced reliability because an operational decision to open breakers will be needed for loss of potential conditions. The corollary would be leaving the element in service with fast tripping enabled for a fault until the loss of potential condition can be diagnosed and corrected.
<p><b>Response:</b> The SDT has modified section 1.6 in response to concerns that applying the standard to elements such as fault detectors that supervise directional distance elements could have a negative impact on reliability. The SDT has modified section 1.6 to include “Supervisory elements associated with current based communication assisted schemes where the scheme is capable of tripping for loss of communications.” The SDT also modified the second bulleted item in section 2.1 (formerly 3.1) to add the clause, “except as noted in section 1.6 above.”</p>		
E.ON U.S. LLC	No	
NPPD	No	
FirstEnergy	Yes	We agree that this standards action is necessary to meet the FERC directives, but have some concerns as we have stated in previous responses above.
<p><b>Response:</b> Thank you for your comments. Please see the summary considerations above.</p>		

Organization	Yes or No	Question 11 Comment
TSGT System Planning Group	Yes	We agree that the scope meets the FERC directive, but some of the proposals in the proposed standard reach beyond the directive.
<p><b>Response: Without additional details, the SDT cannot address the issues that the commenter has with the specific modifications to PRC-023-2 intended to address the FERC directives.</b></p>		
Independent Electricity System Operator	Yes	We general agree with the proposed action but there are detailed changes that we have comments on, which are noted in our comments under Q1 to Q8
<p><b>Response: Thank you for your comments. Please see the summary considerations above.</b></p>		
ComEd	Yes	Yes, given that we assume that NERC must address all the FERC directives whether or not NERC or the industry agrees with them.
<p><b>Response: FERC considered the comments submitted to the original FERC NOPR on PRC-023 and issued directives in Order No. 733 that the SDT must address.</b></p>		
Long Island Power Authority	Yes	LIPA agrees with the scope in general. Please consider our comments above for answers to specific issues.
<p><b>Response: Thank you for your comments. Please see the summary considerations above.</b></p>		
Northeast Power Coordinating Council	Yes	
Bonneville Power Administration	Yes	
Dominion Electric Market Policy	Yes	
Arizona Public Service Company	Yes	
Southern Company	Yes	
NV Energy	Yes	

Organization	Yes or No	Question 11 Comment
Consumers Energy	Yes	
Idaho Power - System Protection	Yes	
Manitoba Hydro	Yes	
American Electric Power	Yes	
Wisconsin Electric		No comment

**12. Are you aware of any regional variances that we should consider with this SAR?**

**Summary Consideration:**

The majority of the commenters did not identify variances for consideration in the SAR. However, several commenters did point out that each Regional Entity has its own definition for BES and should be considered when addressing sub-100 kV facilities. In response, the SDT indicated that Attachment B to the standard will define criteria that Planning Coordinators must apply to determine if a facility must comply with the standard. In addition, FERC issued a BES NOPR on March 18, 2010 proposing a consistent approach to defining BES that (i) provides a 100 kV threshold for facilities that are included in the BES; and (ii) eliminates the currently-allowed discretion of a Regional Entity to define BES within its system without NERC or Commission oversight. In the NOPR, the Commission proposes that a Regional Entity must seek NERC and Commission approval before it exempts a transmission facility rated at 100 kV or above from compliance with mandatory Reliability Standards. In response to the NOPR, NERC submitted comments that supports the Commission’s objectives of ensuring a common understanding and consistent application of the definition of BES across the regions. NERC also supports the Commission’s objective that variations to application of the BES definition should be justified on the basis of reliability. To ensure these objectives are accomplished in a technically and legally appropriate manner, NERC proposed that the Commission should rely on the NERC Reliability Standards Development Process to consider, develop and implement new processes that may be needed, or to enhance existing processes. An Order on the matter has not been issued.

One commenter indicated concern that utilities with long lines and in weak areas will have difficulty protecting their lines and meeting the required loadability. Regions where there are very rural systems will want to write standards that allow adequate protection for their systems. Requirement R1 part 13 states that: “Where other situations present practical limitations on circuit capability, set the phase protection relays so they do not operate at or below 115% of such limitations.” This was included in the standard for such cases where additional criteria are necessary.

Organization	Yes or No	Question 12 Comment
IRC Standards Review Committee	No	We are not aware of any regional variances per se. However, each regional entity has its own definition for BES and this needs to be considered when addressing sub-100 kV facilities.
<p><b>Response: Attachment B to the standard will define criteria that Planning Coordinators must apply to determine if a facility must comply with the standard. In addition, FERC issued a BES NOPR on March 18, 2010 proposing a consistent approach to defining BES that (i) provides a 100 kV</b></p>		

Organization	Yes or No	Question 12 Comment
		<p>threshold for facilities that are included in the BES; and (ii) eliminates the currently-allowed discretion of a Regional Entity to define BES within its system without NERC or Commission oversight. In the NOPR, the Commission proposes that a Regional Entity must seek NERC and Commission approval before it exempts a transmission facility rated at 100 kV or above from compliance with mandatory Reliability Standards. In response to the NOPR, NERC submitted comments that support the Commission’s objectives of ensuring a common understanding and consistent application of the definition of BES across the regions. NERC also supports the Commission’s objective that variations to application of the BES definition should be justified on the basis of reliability. To ensure these objectives are accomplished in a technically and legally appropriate manner, NERC proposed that the Commission should rely on the NERC Reliability Standards Development Process to consider, develop and implement new processes that may be needed, or to enhance existing processes. An Order on the matter has not been issued.</p>
ISO New England Inc.	No	<p>We are not aware of any regional variances per se. However, each regional entity has its own definition for BES and this needs to be considered when addressing sub-100 kV facilities.</p>
		<p><b>Response:</b> Attachment B to the standard will define criteria that Planning Coordinators must apply to determine if a facility must comply with the standard. In addition, FERC issued a BES NOPR on March 18, 2010 proposing a consistent approach to defining BES that (i) provides a 100 kV threshold for facilities that are included in the BES; and (ii) eliminates the currently-allowed discretion of a Regional Entity to define BES within its system without NERC or Commission oversight. In the NOPR, the Commission proposes that a Regional Entity must seek NERC and Commission approval before it exempts a transmission facility rated at 100 kV or above from compliance with mandatory Reliability Standards. In response to the NOPR, NERC submitted comments that support the Commission’s objectives of ensuring a common understanding and consistent application of the definition of BES across the regions. NERC also supports the Commission’s objective that variations to application of the BES definition should be justified on the basis of reliability. To ensure these objectives are accomplished in a technically and legally appropriate manner, NERC proposed that the Commission should rely on the NERC Reliability Standards Development Process to consider, develop and implement new processes that may be needed, or to enhance existing processes. An Order on the matter has not been issued.</p>
Long Island Power Authority	Yes	<p>NPCC BPS definition based on A10 criteria is a regional variance.</p>
		<p><b>Response:</b> Attachment B to the standard will define criteria that Planning Coordinators must apply to determine if a facility must comply with the standard. In addition, FERC issued a BES NOPR on March 18, 2010 proposing a consistent approach to defining BES that (i) provides a 100 kV threshold for facilities that are included in the BES; and (ii) eliminates the currently-allowed discretion of a Regional Entity to define BES within its system without NERC or Commission oversight. In the NOPR, the Commission proposes that a Regional Entity must seek NERC and Commission approval before it exempts a transmission facility rated at 100 kV or above from compliance with mandatory Reliability Standards. In response to the NOPR, NERC submitted comments that support the Commission’s objectives of ensuring a common understanding and consistent application of the definition of BES across the regions. NERC also supports the Commission’s objective that variations to application of the BES definition should be justified on the basis of reliability. To ensure these objectives are accomplished in a technically and legally appropriate manner, NERC proposed that the Commission should rely on the NERC Reliability Standards Development Process to consider, develop and implement new processes that may be needed, or to enhance existing processes. An Order on the matter has not been issued.</p>

Organization	Yes or No	Question 12 Comment
ITC Holdings		Utilities with long lines and in weak areas will have difficulty protecting their lines and meeting the required loadability. Regions where there are very rural systems will want to write standards that allow adequate protection for their systems.
<p><b>Response: Requirement R1 part 13 states that: “Where other situations present practical limitations on circuit capability, set the phase protection relays so they do not operate at or below 115% of such limitations.” This was included in the standard for such cases where additional criteria are necessary.</b></p>		
Northeast Power Coordinating Council	No	
Pepco Holdings, Inc - Affiliates	No	
PSEG Companies	No	
Bonneville Power Administration	No	
FirstEnergy	No	
MRO's NERC Standards Review Subcommittee	No	
Dominion Electric Market Policy	No	
E.ON U.S. LLC	No	
Arizona Public Service Company	No	
American Transmission Company	No	
PacifiCorp	No	
Southern Company	No	

Organization	Yes or No	Question 12 Comment
TSGT System Planning Group	No	
NV Energy	No	
NPPD	No	
Consumers Energy	No	
Idaho Power - System Protection	No	
Kansas City Power & Light	No	
Independent Electricity System Operator	No	
ComEd	No	
Manitoba Hydro	No	
Wisconsin Electric	No	
Ameren	No	
American Electric Power	No	
	No	
Duke Energy	No	



**13. Are you aware of any associated business practices that we should consider with this SAR?**

**Summary Consideration:**

Commenters did not indicate that there are any business practices that the team should consider with the SAR.

One commenter suggested that R2 should be modified to read “The Each Transmission Owner, Generator Owner, or and Distribution Provider that uses a circuit capability with the practical limitations described in Requirement R1, Settings 1.6, R1.7, R1.8, R1.9, R1.12, or R1.13 shall use the calculated circuit capability as the Facility Rating of the circuit and shall forward this information to the Planning Coordinator, Transmission Operator, and Reliability Coordinator. The burden for acknowledging agreement or specifying reasons for disagreement should reside with the Planning Coordinator, Transmission Operator, and Reliability Coordinator. The commenter suggested that the SDT develop additional requirements similar to those in FAC-008 @ R2 and R3. This proposal is outside the scope of the SAR that is intended to limit the project to addressing the directives in Order No. 733. This suggestion could be made when the standard is reviewed during the required 5-year review of the standard.

Organization	Yes or No	Question 13 Comment
Northeast Power Coordinating Council	No	
Pepco Holdings, Inc - Affiliates	No	
PSEG Companies	No	
Bonneville Power Administration	No	
FirstEnergy	No	
IRC Standards Review Committee	No	
MRO's NERC Standards Review	No	

Organization	Yes or No	Question 13 Comment
Subcommittee		
E.ON U.S. LLC	No	
Arizona Public Service Company	No	
American Transmission Company	No	
PacifiCorp	No	
Southern Company	No	
TSGT System Planning Group	No	
Consumers Energy	No	
Idaho Power - System Protection	No	
Kansas City Power & Light	No	
Independent Electricity System Operator	No	
ComEd	No	
Manitoba Hydro	No	
Wisconsin Electric	No	
ISO New England Inc.	No	
Long Island Power Authority	No	

Organization	Yes or No	Question 13 Comment
Ameren	No	
American Electric Power	No	
ITC Holdings	No	
	No	
Duke Energy	No	
NPPD	Yes	See Question 7.

## Standard Development Timeline

*This section is maintained by the drafting team during the development of the standard and will be removed when the standard becomes effective.*

### Development Steps Completed

1. SAR posted for comment from August 19, 2010 through September 19, 2010.
2. SC authorized moving the SAR forward to standard development on August 12, 2010.
3. SC authorized initial posting of draft 1 on April 24, 2014.

### Description of Current Draft

The Protection System Response to Power Swings Standard Drafting Team (PSRPS SDT) is posting Draft 1 of PRC-026-1 – Relay Performance During Stable Power Swings for a 45-day initial comment period and concurrent/parallel initial ballot in the last ten days of the comment period.

Anticipated Actions	Anticipated Date
45-day Formal Comment Period with Concurrent/Parallel Initial Ballot	April 2014
45-day Formal Comment Period with Concurrent/Parallel Additional Ballot	July 2014
Final Ballot	September 2014
BOT Adoption	November 2014

### Version History

Version	Date	Action	Change Tracking
1.0	TBD	Effective Date	New

### Definitions of Terms Used in Standard

*This section includes all newly defined or revised terms used in the proposed standard. Terms already defined in the Glossary of Terms Used in Reliability Standards are not repeated here. New or revised definitions listed below become approved when the proposed standard is approved. When the standard becomes effective, these defined terms will be removed from the individual standard and added to the Glossary.*

**Term:** None.

*When this standard has received ballot approval, the text boxes will be moved to the Application Guidelines Section of the Standard.*

## **A. Introduction**

- 1. Title:** Relay Performance During Stable Power Swings
- 2. Number:** PRC-026-1
- 3. Purpose:** To ensure that load-responsive protective relays do not trip in response to stable power swings during non-Fault conditions.
- 4. Applicability:**
  - 4.1. Functional Entities:**
    - 4.1.1** Generator Owner that applies load-responsive protective relays at the terminals of the Elements listed in Section 4.2, Facilities.
    - 4.1.2** Planning Coordinator.
    - 4.1.3** Reliability Coordinator.
    - 4.1.4** Transmission Owner that applies load-responsive protective relays at the terminals of the Elements listed in Section 4.2, Facilities.
    - 4.1.5** Transmission Planner.
  - 4.2. Facilities:** The following Bulk Electric System (BES) Elements:
    - 4.2.1** Generators.
    - 4.2.2** Transformers.
    - 4.2.3** Transmission lines.

## **5. Background:**

This is Phase 3 of a three-phased standard development that is focused on developing a new Reliability Standard, PRC-026-1 – Relay Performance During Stable Power Swings, to address protective relay operations due to stable power swings. The March 18, 2010, FERC Order No. 733, approved Reliability Standard PRC-023-1 – Transmission Relay Loadability. In this Order, FERC directed NERC to address three areas of relay loadability that include modifications to the approved PRC-023-1, development of a new Reliability Standard to address generator protective relay loadability, and a new Reliability Standard to address the operation of protective relays due to stable power swings. This project’s SAR addresses these directives with a three-phased approach to standard development.

Phase 1 focused on making the specific modifications to PRC-023-1 and was completed in the approved Reliability Standard PRC-023-2, which became mandatory on July 1, 2012.

Phase 2 focused on developing a new Reliability Standard, PRC-025-1 – Generator Relay Loadability, to address generator protective relay loadability; PRC-025-1 is currently awaiting regulatory approval.

This Phase 3 of the project focuses on developing a new Reliability Standard, PRC-026-1 – Relay Performance During Stable Power Swings, to address protective relay operations due to stable power swings. This Reliability Standard will establish requirements aimed at preventing protective relays from tripping unnecessarily due to stable power swings by requiring each Transmission Owner and Generator Owner to assess the security of protective relay systems that are susceptible to operation during power swings, and take actions to improve security for stable power swings where such actions would not compromise dependable operation for faults and unstable power swings.

**6. Effective Date:**

First day of the first full calendar year that is twelve months beyond the date that this standard is approved by applicable regulatory authorities, or in those jurisdictions where regulatory approval is not required, the standard becomes effective on the first day of the first full calendar year that is twelve months beyond the date this standard is approved by the NERC Board of Trustees, or as otherwise made effective pursuant to the laws applicable to such ERO governmental authorities.

**B. Requirements and Measures**

**R1.** Each Planning Coordinator, Reliability Coordinator, and Transmission Planner shall, within the first month of each calendar year, identify and provide notification to the respective Generator Owner and Transmission Owner of each Element that meets one or more of the following criteria, if any: [*Violation Risk Factor: Medium*] [*Time Horizon: Operations Planning, Long-term Planning*]

Criteria:

1. An Element that is located or terminates at a generating plant, where a generating plant stability constraint exists and is addressed by an operating limit or a Special Protection System (SPS) (including line-out conditions).
2. An Element that is associated with a System Operating Limit (SOL) that has been established based on stability constraints identified in system planning or operating studies (including line-out conditions).
3. An Element that has formed the boundary of an island within an angular stability planning simulation where the system Disturbance(s) that caused the islanding condition continues to be a credible event.
4. An Element identified in the most recent Planning Assessment where relay tripping occurred for a power swing during a Disturbance.

**M1.** Each Planning Coordinator, Reliability Coordinator, and Transmission Planner shall have dated evidence that demonstrates identification and the respective notification of the Element(s), if any, which meet one or more of the criteria in Requirement R1. Evidence may include, but is not limited to, the following documentation: emails, facsimiles, records, reports, transmittals, lists, or spreadsheets.

**Rationale for R1:** The Planning Coordinator, Reliability Coordinator, and Transmission Planner are in positions to identify Elements which meet the criteria, if any. The criterion-based approach is consistent with the NERC System Protection and Control Subcommittee (SPCS) technical document *Protection System Response to Power Swings*, August 2013, which recommended a focused approach to determine an at-risk Element. Requirements R1, R2, and R3 collectively form an annual assessment. Identification of the Element(s) in the first month of the calendar year allows the remaining time in the calendar year for the relay owners to evaluate Protection Systems (Requirement R3).

**R2.** Each Generator Owner and Transmission Owner shall, once each calendar year, identify each Element for which it applies a load-responsive protective relay at a terminal of an Element that meets either of the following criteria, if any: [*Violation Risk Factor: Medium*] [*Time Horizon: Operations Planning, Long-term Planning*]

Criteria:

1. An Element that has tripped since January 1, 2003, due to a power swing during an actual system Disturbance where the Disturbance(s) that caused the trip due to a power swing continues to be credible.
2. An Element that has formed the boundary of an island since January 1, 2003, during an actual system Disturbance where the Disturbance(s) that caused the islanding condition continues to be credible.

**M2.** Each Generator Owner and Transmission Owner shall have dated evidence that demonstrates identification of the Element(s), if any, which meet either of the criteria in Requirement R2. Evidence may include, but is not limited to, the following documentation: emails, facsimiles, records, reports, transmittals, lists, or spreadsheets.

**Rationale for R2:** The Generator Owner and Transmission Owner are in positions to identify which load-responsive protective relays have tripped due to power swings, if any. The criterion-based approach is consistent with the NERC System Protection and Control Subcommittee (SPCS) technical document *Protection System Response to Power Swings*, August 2013, which recommended a focused approach to determine an at-risk Element. Requirements R1, R2, and R3 collectively form an annual assessment. The time period in Requirement R2 and R3 allows the relay owners to allocate time during the calendar year to identify the Element(s) and to evaluate Protection Systems based on their particular circumstances.



- R3.** Each Generator Owner and Transmission Owner shall, once each calendar year, perform one of the following for each Element identified pursuant to Requirement R1 or R2: [*Violation Risk Factor: Medium*] [*Time Horizon: Operations Planning, Long-term Planning*]
- Demonstrate that the existing Protection System is not expected to trip in response to a stable power swing based on the criterion below.
  - Demonstrate that the existing Protection System is not expected to trip in response to a stable power swing because power swing blocking is applied.
  - Develop a Corrective Action Plan (CAP) to modify the Protection System so that the Protection System is not expected to trip in response to a stable power swing based on the criterion below or by applying power swing blocking.
  - If none of the options above results in dependable fault detection or dependable out-of-step tripping:
    - a. obtain agreement from the respective Planning Coordinator, Reliability Coordinator, and Transmission Planner of the Element that the existing Protection System design and settings are acceptable, or
    - b. obtain agreement from the respective Planning Coordinator, Reliability Coordinator, and Transmission Planner of the Element that a modification of the Protection System design, settings, or both are acceptable, and develop a CAP for this modification of the Protection System.

Criterion:

A distance relay impedance characteristic, used for tripping, that is completely contained within the lens characteristic formed in the impedance (R-X) plane that connects the endpoints of the total system impedance by varying the sending end and receiving end voltages from 0 to 1.0 per unit, while maintaining a constant system separation angle across the total system impedance where:

1. The system separation angle is:
  - At least 120 degrees where power swing blocking is not applied, or
  - An angle less than 120 degrees as agreed upon by the Planning Coordinator, Reliability Coordinator, and Transmission Planner where power swing blocking is not applied.
2. All generation is in service and all transmission Elements are in their normal operating state.
3. Sub-transient reactance is used for all machines.

- M3.** Each Generator Owner and Transmission Owner shall have dated evidence that demonstrates one of the options was performed according to Requirement R3. Evidence may include, but is not limited to, the following documentation: apparent impedance characteristic plots, email, design drawings, facsimiles, R-X plots, software output, records, reports, transmittals, lists, settings sheets, or spreadsheets.

**Rationale for R3:** Performing one of the options in Requirement R3 assures that the reliability goal of this standard will be met. The first option ensures that the Generator Owner and Transmission Owner protective relays are secure from tripping in response to stable power swings having a system separation angle of up to 120 degrees. The second option allows the Generator Owner and Transmission Owner to exclude protective relays that have power swing blocking applied. The third option allows the Generator Owner and Transmission Owner, where possible, to modify the Protection System to meet the criterion or apply power swing blocking. The fourth option allows the Generator Owner and Transmission Owner to maintain a balance between Protection System security and dependability for cases where tripping on stable power swings may be necessary to maintain the ability to trip for unstable power swings or faults; however, agreement is required by others to ensure that tripping for a stable power swing is acceptable. Protection System modifications may be necessary to achieve acceptable performance. A time period of once each calendar year allows time to evaluate the Protection System, develop a CAP, or obtain necessary agreement.

- R4.** Each Generator Owner and Transmission Owner shall implement each CAP developed pursuant to Requirement R3, and update each CAP if actions or timetables change, until all actions are complete. [*Violation Risk Factor: Medium*][*Time Horizon: Operations Planning, Long-Term Planning*]
- M4.** The Generator Owner and Transmission Owner shall have dated evidence that demonstrates implementation of each CAP according to Requirement R4, including updates to actions or timetables. Evidence may include, but is not limited to, the following documentation: corrective action plans, maintenance records, settings sheets, project or work management program records, or work orders.

**Rationale for R4:** Implementation of the CAP must accomplish all identified actions to be complete to achieve the desired reliability goal. During the course of implementing a CAP, updates may be necessary for a variety of reasons such as new information, scheduling conflicts, or resource issues. Documenting changes and completion of activities provides measurable progress and confirmation of completion.

## C. Compliance

### 1. Compliance Monitoring Process

#### 1.1. Compliance Enforcement Authority

As defined in the NERC Rules of Procedure, “Compliance Enforcement Authority” (CEA) means NERC or the Regional Entity in their respective roles of monitoring and enforcing compliance with the NERC Reliability Standards.

## 1.2. Evidence Retention

The following evidence retention periods identify the period of time an entity is required to retain specific evidence to demonstrate compliance. For instances where the evidence retention period specified below is shorter than the time since the last audit, the CEA may ask an entity to provide other evidence to show that it was compliant for the full time period since the last audit.

The Generator Owner, Planning Coordinator, Reliability Coordinator, Transmission Owner, and Transmission Planner shall keep data or evidence to show compliance as identified below unless directed by its CEA to retain specific evidence for a longer period of time as part of an investigation.

- The Planning Coordinator, Reliability Coordinator, and Transmission Planner shall retain evidence of Requirements R1, Measures M1 for three calendar years.
- The Generator Owner and Transmission Owner shall retain evidence of Requirements R2 and R3, Measures M2 and M3 for three calendar years.
- The Generator Owner and Transmission Owner shall retain evidence of Requirements R4, Measures M4 for 12 calendar months following completion of each CAP.

If a Generator Owner, Planning Coordinator, Reliability Coordinator, Transmission Owner, or Transmission Planner is found non-compliant, it shall keep information related to the non-compliance until mitigation is complete and approved, or for the time specified above, whichever is longer.

The CEA shall keep the last audit records and all requested and submitted subsequent audit records.

## 1.3. Compliance Monitoring and Assessment Processes:

Compliance Audit

Self-Certification

Spot Checking

Compliance Violation Investigation

Self-Reporting

Complaint

## 1.4. Additional Compliance Information

None.

Table of Compliance Elements

R #	Time Horizon	VRF	Violation Severity Levels			
			Lower VSL	Moderate VSL	High VSL	Severe VSL
<b>R1</b>	Operations Planning, Long-term Planning	Medium	The responsible entity identified an Element and provided notification in accordance with Requirement R1, but was less than or equal to 30 calendar days late.	The responsible entity identified an Element and provided notification in accordance with Requirement R1, but was more than 30 calendar days and less than or equal to 60 calendar days late.	The responsible entity identified an Element and provided notification in accordance with Requirement R1, but was more than 60 calendar days and less than or equal to 90 calendar days late.	The responsible entity identified an Element and provided notification in accordance with Requirement R1, but was more than 90 calendar days late.  OR The responsible entity failed to identify an Element or to provide notification in accordance with Requirement R1.
<b>R2</b>	Operations Planning, Long-term Planning	Medium	The responsible entity identified Element in accordance with Requirement R2, but was less than or equal to 30 calendar days late.	The responsible entity identified Element in accordance with Requirement R2, but was more than 30 calendar days and less than or equal to 60 calendar days late.	The responsible entity identified Element in accordance with Requirement R2, but was more than 60 calendar days and less than or equal to 90 calendar days late.	The responsible entity identified Element in accordance with Requirement R2, but was more than 90 calendar days late.  OR

R #	Time Horizon	VRF	Violation Severity Levels			
			Lower VSL	Moderate VSL	High VSL	Severe VSL
						The responsible entity failed to identify an Element in accordance with Requirement R2.
<b>R3</b>	Operations Planning, Long-term Planning	Medium	The responsible entity performed one of the options in accordance with Requirement R3, but was less than or equal to 30 calendar days late.	The responsible entity performed one of the options in accordance with Requirement R3, but was more than 30 calendar days and less than or equal to 60 calendar days late.	The responsible entity performed one of the options in accordance with Requirement R3, but was more than 60 calendar days and less than or equal to 90 calendar days late.	The responsible entity performed one of the options in accordance with Requirement R3, but was more than 90 calendar days late.  OR The responsible entity failed to perform one of the options in accordance with Requirement R3.
<b>R4</b>	Operations Planning, Long-term Planning	Medium	The responsible entity implemented, but failed to update a CAP, when actions or timetables changed, in accordance with Requirement R4.	N/A	N/A	The responsible entity failed to implement a CAP in accordance with Requirement R4.

#### D. Regional Variances

None.

#### E. Interpretations

None.

#### F. Associated Documents

IEEE Power System Relaying Committee WG D6. *Power Swing and Out-of-Step Considerations on Transmission Lines*. July 2005.

Kundar, Prabha. *Power System Stability and Control*. 1994. Palo Alto: EPRI, McGraw Hill, Inc.

NERC System Protection and Control Subcommittee. *Protection System Response to Power Swings*. August 2013: [http://www.nerc.com/comm/PC/System%20Protection%20and%20Control%20Subcommittee%20SPCS%2020/SPCS%20Power%20Swing%20Report\\_Final\\_20131015.pdf](http://www.nerc.com/comm/PC/System%20Protection%20and%20Control%20Subcommittee%20SPCS%2020/SPCS%20Power%20Swing%20Report_Final_20131015.pdf).

Reimert, Donald. *Protective Relaying for Power Generation Systems*. 2006. Boca Raton: CRC Press.

### Guidelines and Technical Basis

#### Introduction

The NERC System Protection and Control Subcommittee technical document, *Protection System Response to Power Swings*, August 2013<sup>1</sup> (“PSRPS Report” or “report”) was specifically prepared to support the development of this NERC Reliability Standard. The report provided a historical perspective on power swings as early as 1965 up through the approval of the report by the NERC Planning Committee. The report also addresses reliability issues regarding trade-offs between security and dependability of protection systems, considerations for this NERC Reliability Standard, and a collection of technical information about power swing characteristics and varying issues with practical applications and approaches to power swings. Of these topics, the PSRPS Report suggests an approach for this NERC Reliability Standard (“standard” or “PRC-026-1”) which is consistent with addressing two of the three regulatory directives in the FERC Order No. 733. The first directive concerns the need for “...protective relay systems that differentiate between faults and stable power swings and, when necessary, phases out protective relay systems that cannot meet this requirement.”<sup>2</sup> Second, is “...to develop a Reliability Standard addressing undesirable relay operation due to stable power swings.”<sup>3</sup> The third directive “...to consider “islanding” strategies that achieve the fundamental performance for all islands in developing the new Reliability Standard addressing stable power swings”<sup>4</sup> was considered during development of the standard.

The development of this NERC Reliability Standard implements the majority of the approach suggested by the PSRPS Report. These guidelines include a narrative of any deviation in the report’s approach.

#### Burden to Entities

The PSRPS Report provides a technical basis and approach for focusing on Protection Systems which are susceptible to power swings while achieving the reliability objective. The approach reduces the number of relays for which the requirements would apply by first identifying the Bulk Electric System (BES) Element(s) that need to be evaluated. The first step uses criteria to identify a BES Element on which a Protection System is expected to be challenged by power swings. Of those BES Elements, the second step is to identify the Element(s) that apply a load-responsive protective relay. Rather than requiring the Transmission Planner to perform simulations to obtain information for each identified Element(s), the Generator Owner and Transmission Owner will reduce the need for simulation by comparing the load-responsive protective relay characteristic to a specific criterion.

---

<sup>1</sup> NERC System Protection and Control Subcommittee technical document, *Protection System Response to Power Swings*, August 2013: [http://www.nerc.com/comm/PC/System%20Protection%20and%20Control%20Subcommittee%20SPCS%2020/SPCS%20Power%20Swing%20Report\\_Final\\_20131015.pdf](http://www.nerc.com/comm/PC/System%20Protection%20and%20Control%20Subcommittee%20SPCS%2020/SPCS%20Power%20Swing%20Report_Final_20131015.pdf)

<sup>2</sup> Transmission Relay Loadability Reliability Standard, Order No. 733, P.150 FERC ¶ 61,221 (2010).

<sup>3</sup> Ibid. P.153.

<sup>4</sup> Ibid. P.162.

### Applicability

The standard is applicable to the Generator Owner, Planning Coordinator, Reliability Coordinator, Transmission Owner, and Transmission Planner entities. More specifically, the Generator Owner and Transmission Owner entities are applicable when applying load-responsive protective relays at the terminals of the applicable BES Elements. All the entities have a responsibility to identify the Elements which meet specific criteria. The standard is applicable to the following BES Elements: generators, transmission lines, and transformers. The Distribution Provider was considered for inclusion in the standard; however, it is not subject to the standard because this entity by functional registration would not own generators, transmission lines, or transformers other than load serving.

### Requirement R1

In the first month of each calendar year this requirement initiates the identification of the Elements that meet specific criteria known by the Planning Coordinator, Reliability Coordinator, and the Transmission Planner.

Because the dynamic studies performed by the Planning Coordinator and the Transmission Planner vary by region, it is important for both of these entities to have a reliability requirement to identify such Elements. The Reliability Coordinator is also included because of its wide-area awareness of the BES and its unique potential to identify Elements susceptible to tripping due to power swings.

The first criterion involves Elements that are located at or terminate at a generating plant where an existing stability constraint has been established and is managed by either a specific operating limit or a Special Protection System (SPS). For example, assume a generating plant contains two 500 MW generating units, one connected to a 345 kV bus and one connected to a 230 kV bus. Assume a single transformer connects the 345 kV bus to the 230 kV bus, and that the plant is connected to the rest of the BES through a single 345 kV transmission circuit and two 230 kV circuits. Assume a stability constraint exists that limits the output of the plant to 700 MW for an outage of the 345 kV transmission line, and that a SPS exists to run back the output of the generating plant to 700 MW for a loss of the 345 kV transmission line. For this hypothetical example, both generating units would be included as Elements meeting the criterion. Furthermore, the generator step-up (GSU) transformers, the generator interconnection, the 345-230 kV power transformer, and the two 230 kV transmission circuits would be identified as Elements meeting the criterion. The 345 kV transmission circuit would not be identified as meeting the criterion since the event that triggered the stability constraint is a loss of the 345 kV transmission circuit.

The second criterion involves Elements that have an established System Operating Limit (SOL) based on a stability limit or issue driven by one or more specific events. For example, if two long parallel 500 kV transmission lines have a combined SOL of 1,200 MW, and this limit is based on angular instability resulting from a fault and subsequent loss of one of the two circuits, then both circuits would be identified as an Element meeting the criterion.

The third criterion involves the Element that has formed the boundary of an island within an angular stability planning simulation. While the island may form due to various transmission circuits tripping for a combination of reasons, such as stable and unstable power swings, faults,



## Application Guidelines

---

and excessive loading, the criterion requires that all lines that tripped in simulation to form the island be identified as meeting the criterion.

The last criterion allows the Planning Coordinator and Transmission Planner to include any other Elements revealed in Planning Assessments.

### Requirement R2

The approach of Requirement R2 requires the Generator Owner and Transmission Owner to identify Elements once each calendar year that meet the focused criteria specific to these entities. The only Elements that are in scope are Elements that meet the criteria and apply a load-responsive protective relay at the terminal of the Element. Using the criteria focuses the reliability concern on the Element that is at-risk.

The first criterion involves Elements that have tripped for actual power swings, regardless of whether the power swing was stable or unstable. In order to ensure previous trips due to power swings are considered, the entity must consider Disturbances since January 1, 2003 in order to capture the August 14, 2003 Blackout.<sup>5</sup> In consideration that BES topologies change, the Requirement includes a provision to exclude the Element where a historical Disturbance is no longer credible; meaning the Disturbance is no longer capable of occurring in the future due to actual changes to the BES.

The second criterion involves the formation of an island based on an actual Disturbance. While the island may form due to various transmission circuits tripping for a combination of reasons, such as power swings (stable or unstable), faults, or excessive loading, the criterion requires that all lines that tripped to form the island be identified as meeting the criterion. This criterion also has an exception similar to the first criterion. Any event that caused an actual island to form since August 1, 2003 that is no longer credible due to actual changes to the BES is not required be used to identify Elements as meeting the criterion.

For example, assume eight lines connect an area containing generation and load to the rest of the BES, and five of the lines terminate on a single straight bus. Assume a forced outage of the straight bus in the past caused an island by tripping open the five lines connecting to the straight bus, and subsequently causing the other three lines into the area to trip on power swings or excessive loading. If the BES is reconfigured such that the five lines into the straight bus are now divided between two different substations, a single Disturbance that caused the five lines to open is no longer a credible event; therefore, these Elements should not be identified as meeting the criterion based on this particular event. If any other event remains credible for the Element, then it would be identified under the criterion.

### Requirement R3

The purpose of Requirement R3 is to provide alternatives for a Generator Owner or Transmission Owner to demonstrate that Protection Systems on identified Elements are not susceptible to tripping in response to power swings meeting specified conditions. It also provides alternatives for

---

<sup>5</sup> <http://www.nerc.com/pa/rrm/ea/pages/blackout-august-2003.aspx>

## Application Guidelines

---

the Generator Owner or Transmission Owner to obtain agreement from its Planning Coordinator, Reliability Coordinator, and Transmission Planner that an existing or modified Protection System is acceptable when providing security for the specified conditions would compromise dependable tripping for faults or unstable power swings.

The first option in Requirement R3 allows the Generator Owner or Transmission Owner to evaluate Elements identified in Requirements R1 or R2 to determine if load-responsive protective relays at the terminals of each identified Element are susceptible to tripping in response to a stable power swing. Specific criteria and system conditions are provided to analyze the characteristic of the load-responsive protective relays of each Element.

The second option in Requirement R3 allows the Generator Owner or Transmission Owner to exclude protective relays if they are blocked from tripping by power swing blocking (PSB). If PSB is applied, it is expected that the relays were set in consultation with the Transmission Planner to verify maximum slip rates, so that proper PSB settings can be applied. It is expected that Elements utilizing PSB relays have been evaluated for susceptibility to tripping in response to stable power swings, and thus can be excluded.

The third option in Requirement R3 allows the Generator Owner or Transmission Owner to modify its Protection System to achieve the desired goal of reducing the likelihood of tripping on a stable power swing. The Generator Owner or Transmission Owner may achieve this goal by meeting the criterion used in the first option or by applying power swing blocking. Modifications to the Protection System could include revising settings or logic, or replacing the Protection System. A Corrective Action Plan (CAP) is employed to allow an entity the flexibility to identify the actions and timetable to make the necessary adjustments. A CAP allows for outage scheduling, time for design, procurement, and installation of new relaying or the application of new settings. The amount of detail regarding the listing of the actions required to make the necessary changes to the Protection System is left to the discretion and management of the entity.

The fourth option in Requirement R3 allows the Generator Owner or Transmission Owner for the situation where making the Protection System secure for stable power swings, either through modified settings or replacement, will either significantly decrease the dependability for tripping for faults within its zone of protection or for tripping for out-of-step conditions. To ensure the risks due to tripping for stable power swings are balanced against the risk due to the reduction in dependability, and that reasonable effort to find viable Protection System modifications has been made, the applicable Generator Owner and Transmission Owner must obtain agreement from the Planning Coordinator, Reliability Coordinator, and Transmission Planner that tripping for a stable power swing is acceptable. The entities may agree that the existing or modified Protection System design and settings are acceptable. This option allows for cases where the existing Protection System design and settings are not acceptable, but modifications that do not meet the criterion in the first option result in an acceptable balance between dependability and security. In these cases, a CAP is employed to allow an entity the flexibility to identify the actions and timetable to make the necessary adjustments. A CAP allows for outage scheduling, time for design, procurement, and installation of new relaying or the application of new settings. The amount of detail regarding the listing of the actions required to make the necessary changes to the Protection System is left to the discretion and management of the entity.

### *Application to Transmission Owners*

The criterion describes a lens characteristic formed in the impedance (R-X) plane that connects the endpoints of the total system impedance together by varying the sending and receiving end system voltages from 0 to 1.0 per unit, while maintaining a constant system separation angle across the total system impedance (Figures 1 and 2). The total system impedance is determined by summing the sending end source impedance, the line impedance in parallel with the Thévenin equivalent transfer impedance, and the receiving end source impedance (Figure 3). This total system source impedance is minimized to create a conservative, worst-case condition by including all transmission Elements that represent a “normal” system configuration with generation set at the value reported to the Transmission Planner. Further, sub-transient generator reactances are used since they are smaller than the transient or synchronous reactances, and result in a smaller source impedance and smaller separation angle in the graphical analysis (Figures 4 and 5).

The source impedances can be obtained by a number of different methods using commercially available short circuit calculation tools.<sup>6</sup> Most short circuit tools have a network reduction feature that allows the user to select the local and remote terminal buses to retain. The first method reduces the system to one that contains two buses, an equivalent generator at each bus (representing the source impedance at the sending and receiving ends), and two parallel lines; one being the line impedance of the protected line with relays being analyzed, the other being the transfer impedance representing all other combinations of lines that connect the two buses together (Figure 3). Another conservative method is to open both ends of the line in question, and apply a three-phase bolted fault at each bus. The resulting source impedance at each end will be less than or equal to the actual source impedance calculated by the network reduction method. Either method can be used to develop the system source impedances at both ends.

The first two bullets of criterion 1, identify the system separation angles to be used to identify the shape and size of the power swing stability boundary used to test load-responsive impedance relay elements. Both bullets test impedance relay elements that are not supervised by power swing blocking. The first bullet evaluates a system separation angle of at least 120 degrees that is held constant while varying the sending and receiving end source voltages from 0 to 1.0 per unit, thus creating a power swing stability boundary shaped like a lens about the system impedance. This lens characteristic is compared to the tripping portion of the distance relay characteristic, that is, the portion that is not supervised by load encroachment logic, or some other form of supervision that restricts the distance element from tripping for heavy, balanced load conditions. If the impedance characteristics are completely contained within the lens characteristic, the Element passes the evaluation (Figures 6 and 7). A system separation angle of 120 degrees was chosen for the evaluation where PSB is not applied because it is generally accepted in the industry that recovery for a swing beyond this angle is unlikely to occur.<sup>7</sup>

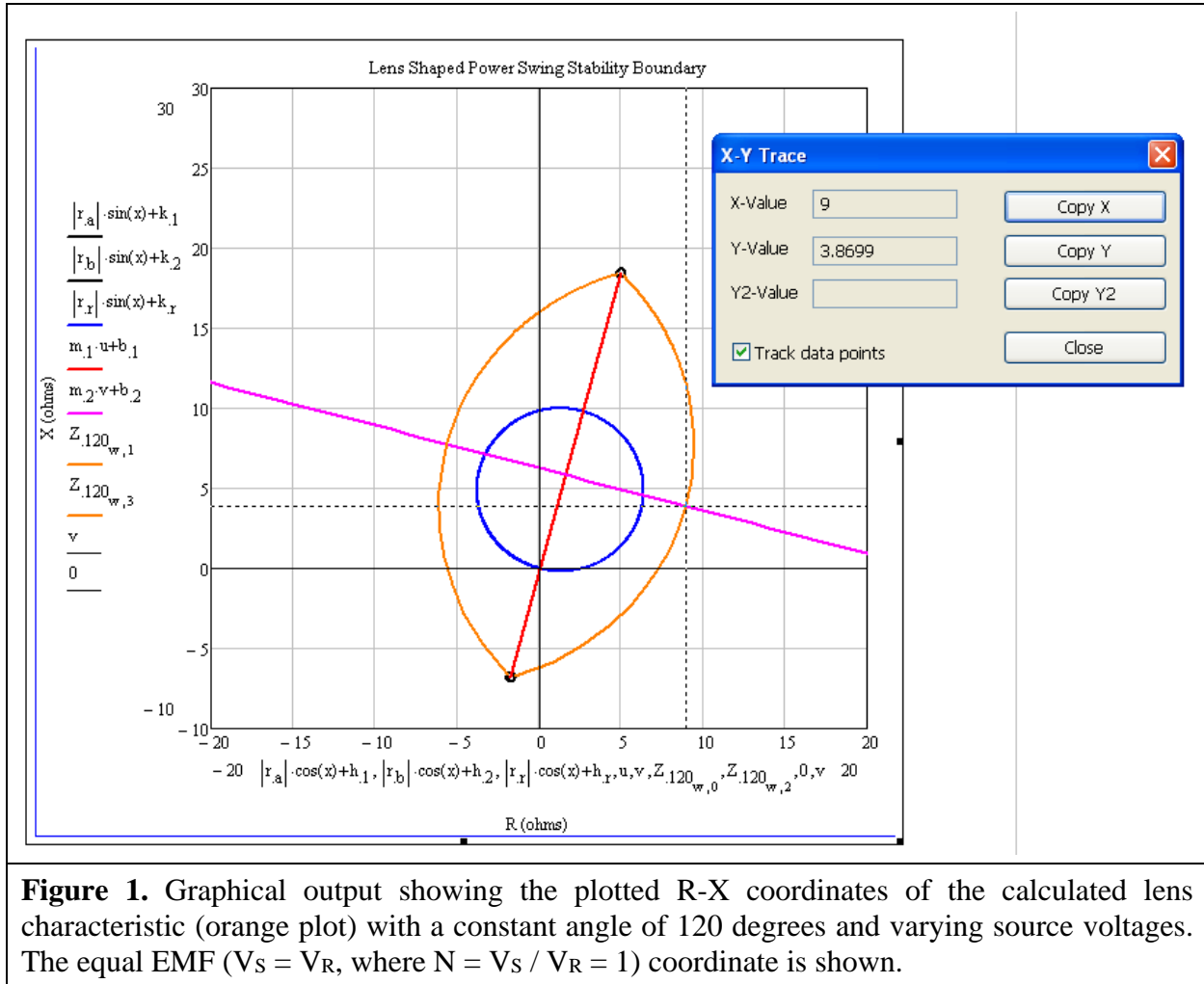
---

<sup>6</sup> Appendix in *Out-Of-Step Protection Fundamentals and Advancements*, by Demetrios A. Tziouvaras and Daqing Hou, available at <https://www.selinc.com> (April 17, 2014).

<sup>7</sup> “The critical angle for maintaining stability will vary depending on the contingency and the system condition at the time the contingency occurs; however, the likelihood of recovering from a swing that exceeds 120 degrees is marginal and 120 degrees is generally accepted as an appropriate basis for setting out-of-step protection. Given the importance of separating unstable systems, defining 120 degrees as the critical angle is appropriate to achieve a

## Application Guidelines

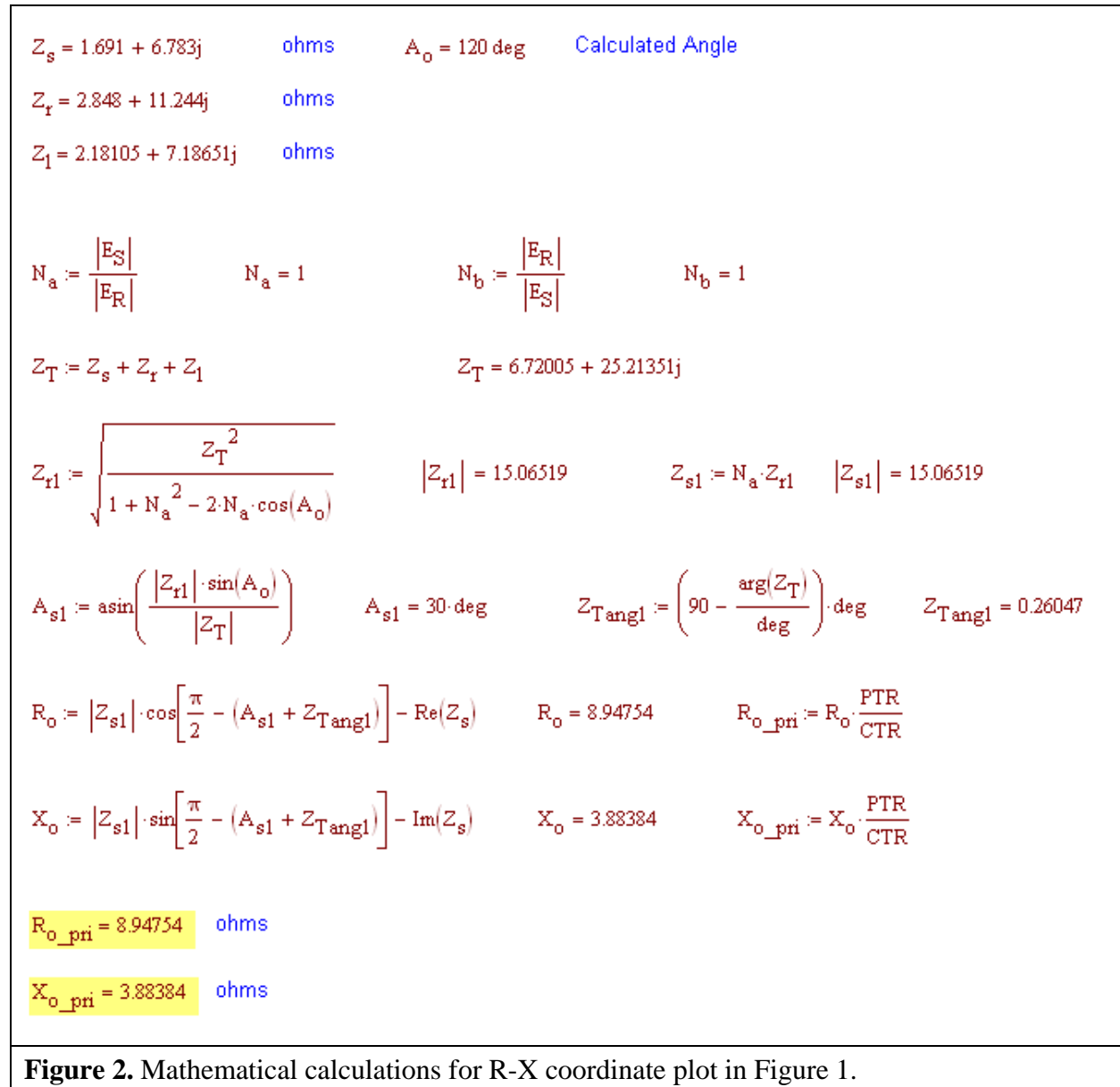
The second bullet evaluates impedance relay elements at a system separation angle of less than 120 degrees, similar to the first criterion bullet described above. The angle evaluated must be agreed upon by the Planning Coordinator, Reliability Coordinator, and Transmission Planner, and tripping of the distance elements for stable power swings should not occur at this angle, as shown by system planning or operating studies.

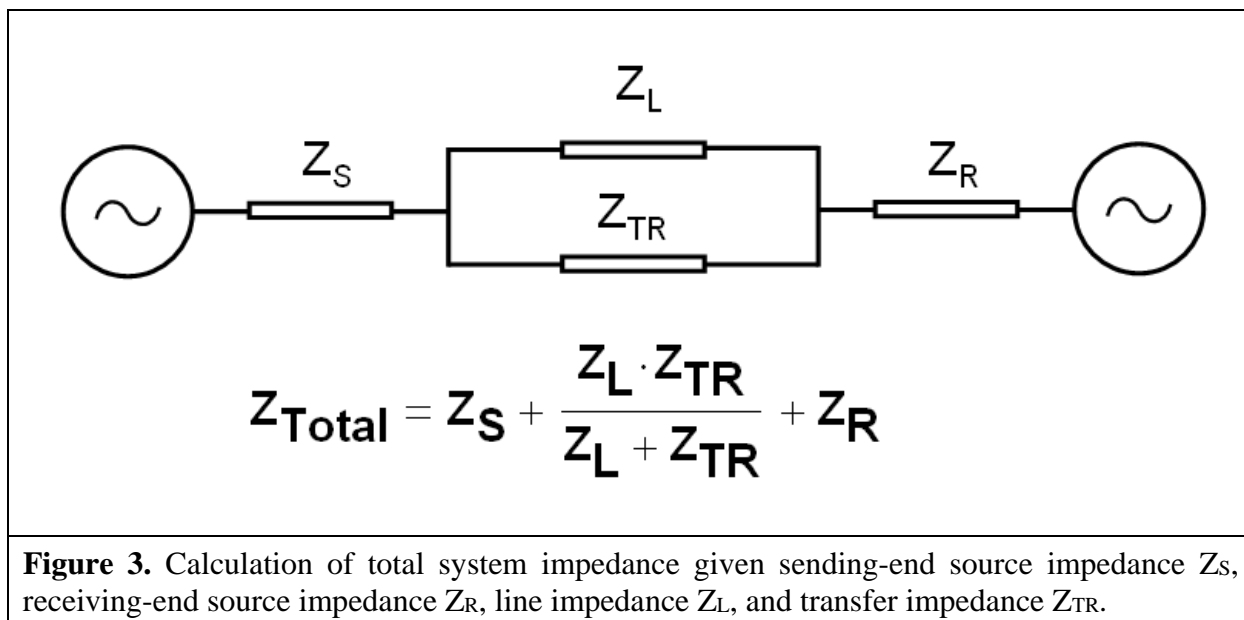


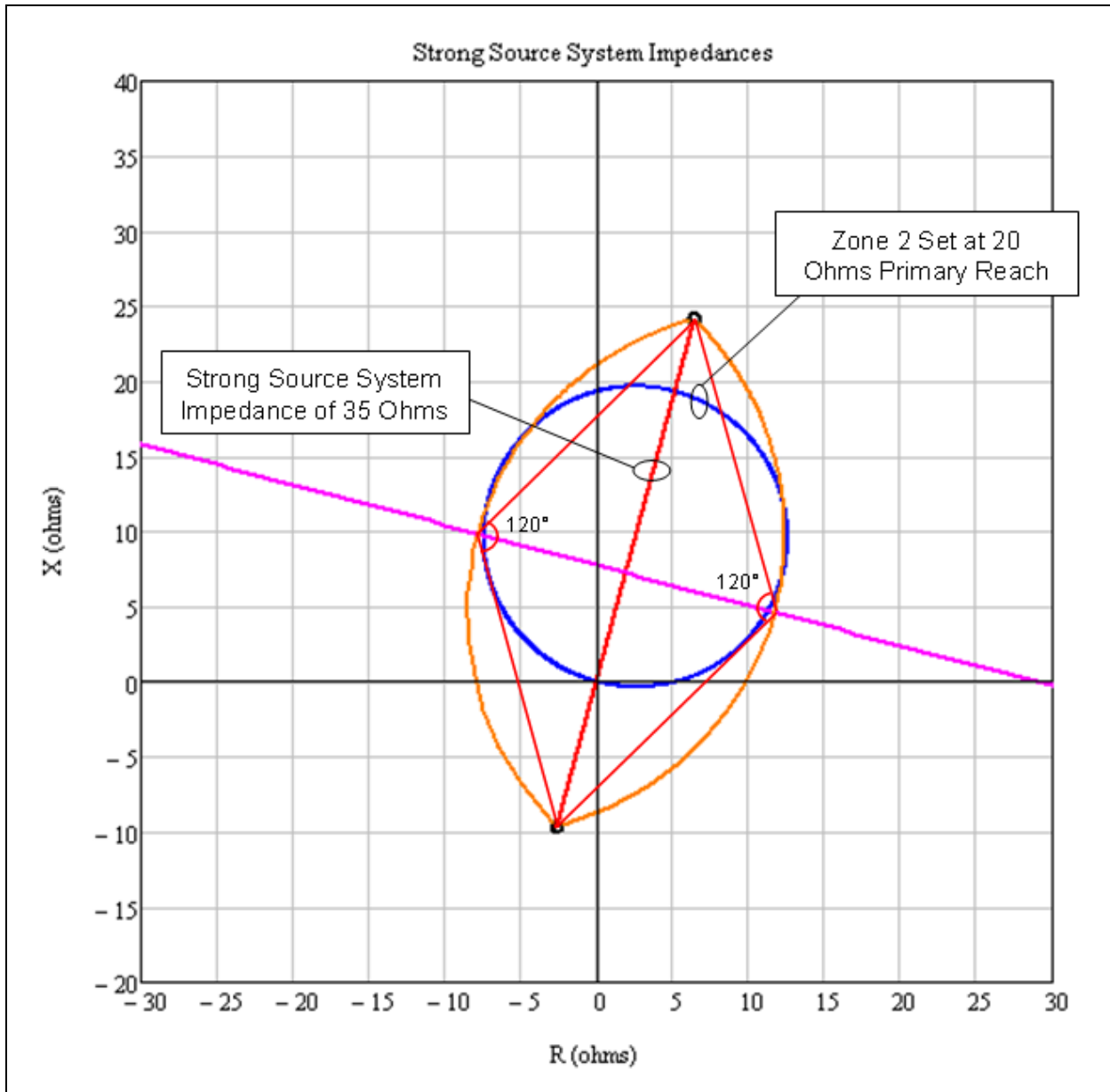
**Figure 1.** Graphical output showing the plotted R-X coordinates of the calculated lens characteristic (orange plot) with a constant angle of 120 degrees and varying source voltages. The equal EMF ( $V_s = V_r$ , where  $N = V_s / V_r = 1$ ) coordinate is shown.

proper balance between dependable tripping for unstable power swings and secure operation for stable power swings.” PSRPS Report at p. 28.

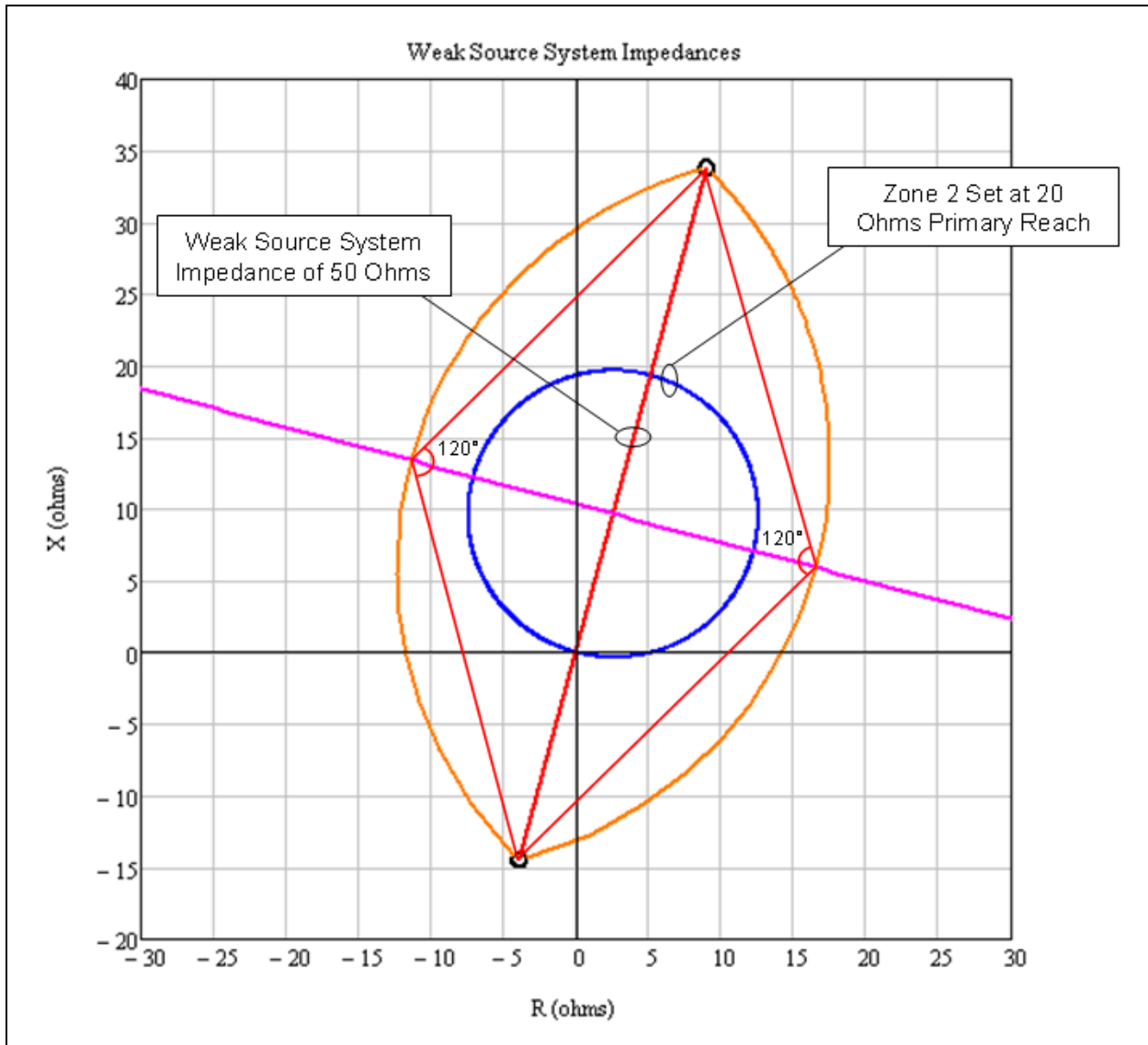
## Application Guidelines





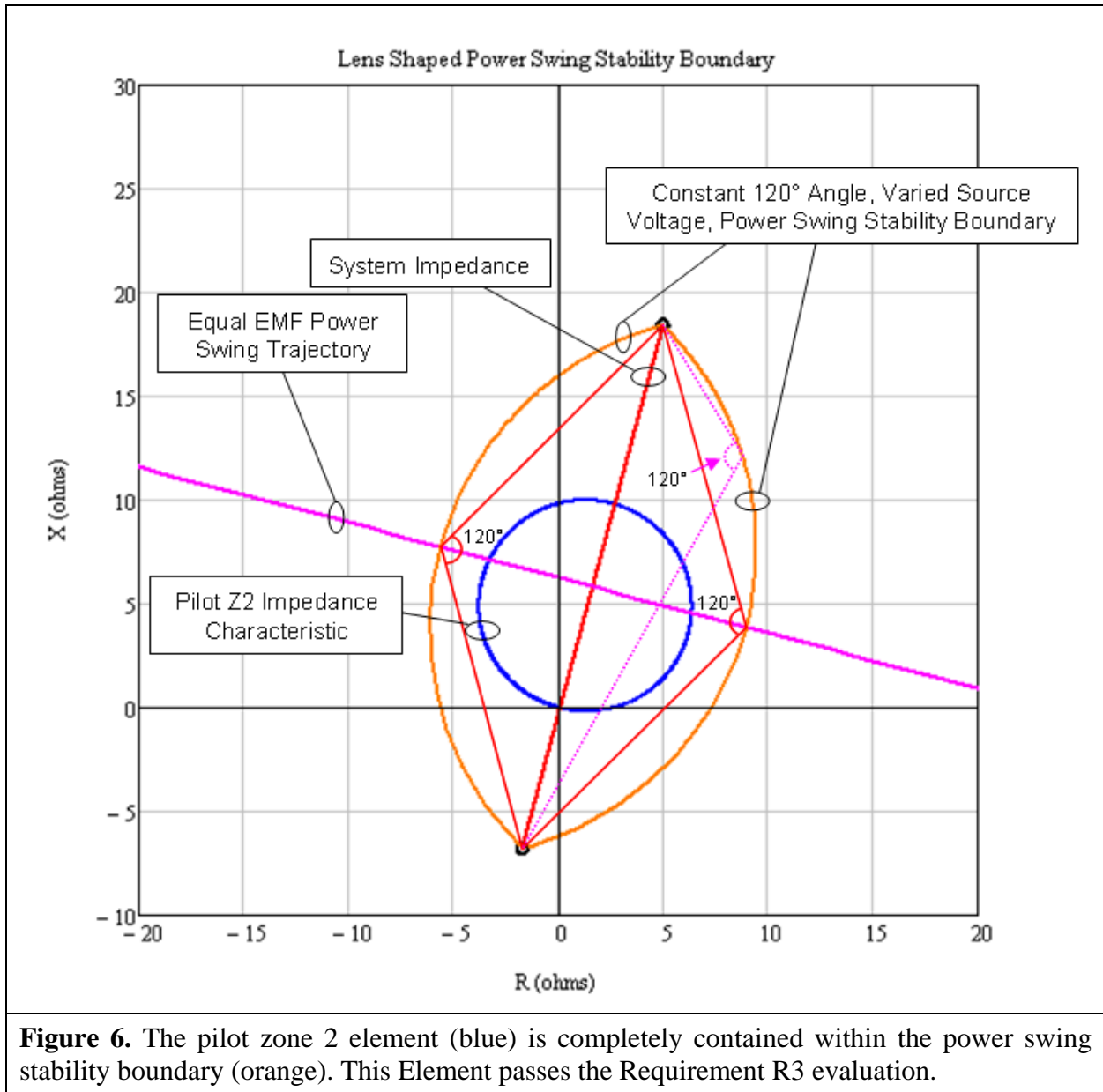


**Figure 4.** A strong-source system with a line impedance of  $Z_{Line} = 16$  ohms is shown. This represents a heavily-loaded system, using a maximum generation profile and using generator sub-transient reactance. The zone 2 mho circle (set at 125% of  $Z_{Line}$ ) extends into the power swing stability boundary (orange lens characteristic). Using the strongest source system is more conservative because it shrinks the power swing stability boundary, bringing it closer to the mho circle.



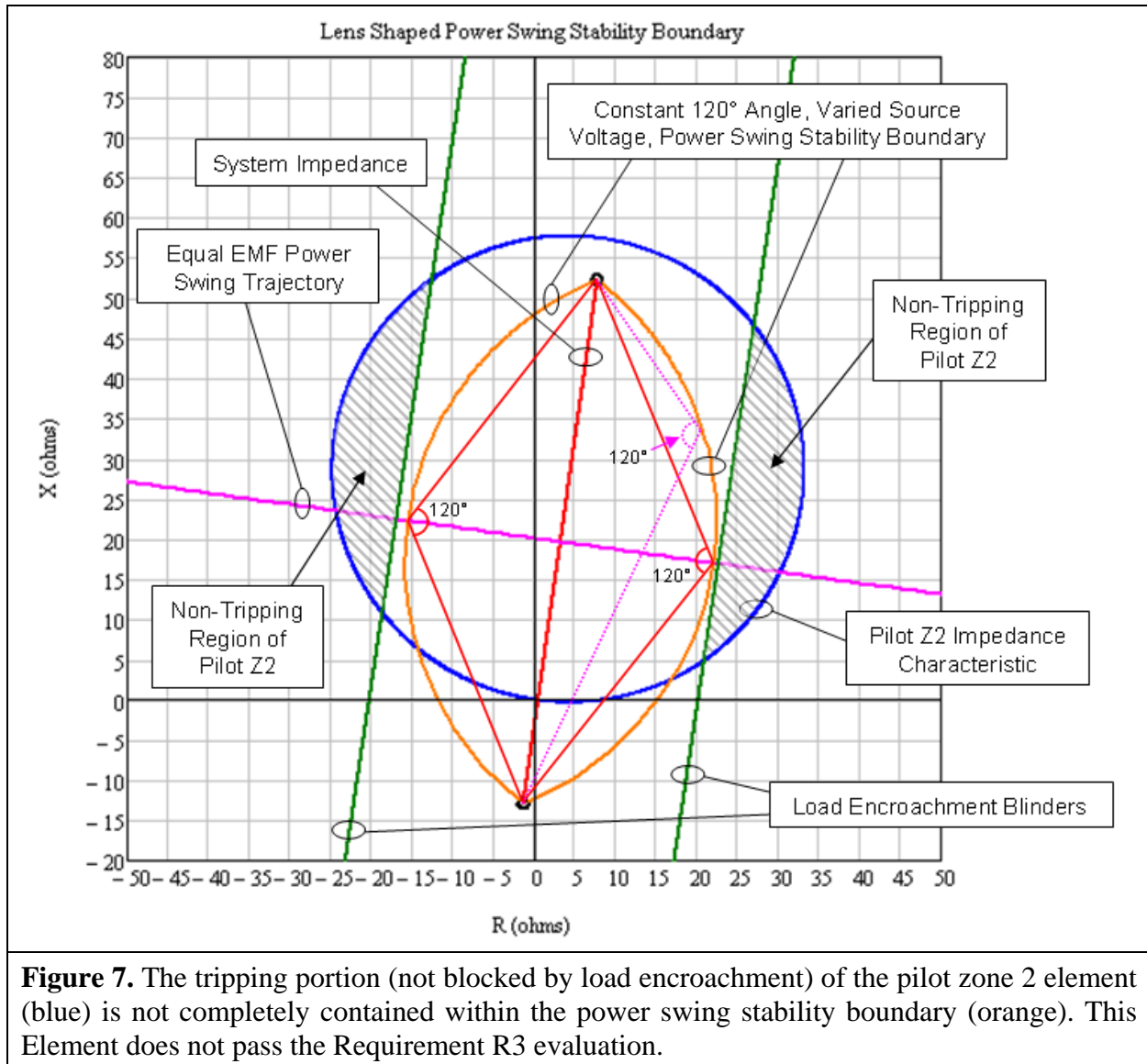
**Figure 5.** A weak-source system with a line impedance of  $Z_{Line} = 16$  ohms is shown. This represents a lightly-loaded system, using a minimum generation profile and/or using generator transient reactance instead of using generator sub-transient reactance. The zone 2 mho circle (set at 125% of  $Z_{Line}$ ) does not extend into the power swing stability boundary (orange lens characteristic). Using a weaker source system expands the power swing stability boundary away from the mho circle.





**Figure 6.** The pilot zone 2 element (blue) is completely contained within the power swing stability boundary (orange). This Element passes the Requirement R3 evaluation.

## Application Guidelines



### *Application to Generator Owners*

Generators have a variety of load responsive protection relays that protect the generator from abnormal operation and are subject to incorrect operation caused by stable power swings. They include protective relays that operate on current or an impedance function. Specific relays are time overcurrent, voltage controlled/restrained overcurrent, loss of field, and distance relays.

### *Impedance Type Relays*

The determination of the apparent impedance at the generator terminals is complex, especially for cases where there are multiple generators connected to a high-voltage bus. There are various quantities that are interdependent as the disturbance progresses through the time domain whether it is a stable or unstable power swing. These variances include changes in machine internal voltage,

## Application Guidelines

---

speed governor action, voltage regulator action, the reaction of other local generators, and the reaction of other interconnected transmission Elements. A transient stability program is used to determine the apparent impedance for best results, especially for relays that are used for transmission line backup protection. Distance and out-of-step relays that are subject to power swings are connected at generator terminals and/or on the high-voltage side of the generator step-up (GSU) transformer. The loss of field relay(s) is connected at the generator terminals.

The electrical center will be in the transmission system for cases where the generator is connected through a weak transmission system (high external system source impedance). Other cases where the generator is connected through a strong transmission system, the electrical center will be inside the unit connected zone. In either case, impedance relays connected at the generator terminals or at the high-voltage side of the GSU may be subject to operation in response to stable power swings. Impedance relays used to back-up transmission protection usually have a time delay trip and are coordinated with local transmission line distance relay protection. Out-of-step relaying subject to a stable power swing may not operate correctly if the settings are not properly applied. If it is anticipated that the electrical center will be in the unit connected zone or the apparent impedance would challenge the relay operation, the Transmission Planner must perform transient stability studies to validate the existence of a power swing condition that a generator may experience. The Generator Owner uses the apparent impedance plot in a time domain to verify correct settings.

The simplified method used in the Application to Transmission Owners section is also used here to provide a helpful understanding of a stable power swing on load-responsive protective relays for those cases where the generator is connected to the transmission system and there are no infeed effects to be considered. For cases where infeed affects the apparent impedance (multiple unit connected generators connected to a transmission switchyard), the Generator Owner will provide the unit and relay data to the Transmission Planner for analysis. The quantities used to determine the apparent impedance characteristics are the generator unsaturated generator  $X''_d$ , GSU impedance, transmission line impedance, and the system equivalent. A voltage range of 0.65 to 1.5 should be considered to cover the delay of internal voltage for generators under manual or automatic voltage control.

### Requirement R4

This requirement ensures that any Corrective Action Plan (CAP) developed in the previous requirement is implemented through completion. Having such a requirement allows the entity's work toward making protection scheme adjustments measurable given the variability of the timetables of each CAP.

To achieve the stated purpose of this standard, which is to ensure that relays do not operate in response to stable power swings during non-fault conditions, the responsible entity is required to implement and complete a CAP that addresses the relays that are at risk of tripping during a stable power swing for the applicable Elements on the BES. Protection System owners are required in the implementation of a CAP to update it when actions or timetable change, until completed. Accomplishing this objective is intended to reduce the risk of the relays unnecessarily tripping during stable power swings, thereby improving reliability and reducing risk to the BES.

## Application Guidelines

---

The following are examples of actions taken to complete CAPs for a relay responding to a stable power swing where a setting change was determined to be acceptable (without diminishing the ability of the relay to protect for faults within its zone of protection).

**Example R4a:** Actions: Settings were issued on 6/02/2014 to reduce the zone 3 reach of the KD-10 relay from 30 ohms to 25 ohms so that the relay characteristic is completely contained within the lens characteristic identified by the criterion. The settings were applied to the relay on 6/25/2014. CAP completed on 06/25/2014.

**Example R4b:** Actions: Settings were issued on 6/02/2014 to enable out-of-step blocking on the SEL-321 relay to prevent tripping in response to stable power swings. The setting changes were applied to the relay on 6/25/2014. CAP completed on 06/25/2014.

The following is an example of actions taken to complete a CAP for a relay responding to a stable power swing that required the addition of an out-of-step blocking relay.

**Example R4c:** Actions: A project for the addition of an out-of-step blocking relay (KS) to supervise the zone 3 (KD-10) relay was initiated on 6/5/2014 to prevent tripping in response to stable power swings. The relay installation was completed on 9/25/2014. CAP completed on 9/25/2014.

The following is an example of actions taken to complete a CAP with a timetable that required updating for the replacement of the relay.

**Example R4d:** Actions: A project for the replacement of the KD-10 relays at both terminals of line X with GE L90 relays was initiated on 6/5/2014 to prevent tripping in response to stable power swings. The completion of the project was postponed due to line outage rescheduling from 11/15/2014 to 3/15/2015. Following the timetable change, the KD-10 relay replacement was completed on 3/18/2015. CAP completed on 3/18/2015.

The CAP is complete when all the documented actions to resolve the specific problem (i.e., unnecessary tripping during stable power swings) are completed.

## Implementation Plan

### Project 2010-13.3 – Relay Loadability: Stable Power Swings

#### Requested Approvals

PRC-026-1 – Relay Performance During Stable Power Swings

#### Requested Retirements

None.

#### Prerequisite Approvals

None.

#### General Considerations

There are a number of factors that influence the determination of an implementation period for the new proposed standard. The following factors may be specific to one or more of the applicable entities listed below.

1. The effort and resources for all applicable entities to develop or modify internal processes and/or procedures.
2. The effort and resources for all applicable entities to identify the Element(s) according to the criterion in the Requirements.
3. The need for the Generator Owner or Transmission Owner to secure resources (e.g., availability of consultants, if needed) to evaluate each load-responsive protective relay's response to a stable power swing for identified Elements.
4. The need for the Generator Owner or Transmission Owner to obtain agreement from the Planning Coordinator, Reliability Coordinator, and Transmission Planner where necessary.
5. The amount of work that the Generator Owner or Transmission Owner will need from a Planning Coordinator or Transmission Planner to perform simulations.
6. The period of time for a Generator Owner or Transmission Owner to take an Element outage, if necessary, to modify the Protection System is driven through the Corrective Action Plan (CAP) and is independent of the standard's implementation period. The CAP includes its own timetable which is at the discretion of the entity.

**Applicable Entities**

Generator Owner  
Planning Coordinator  
Reliability Coordinator  
Transmission Owner  
Transmission Planner

**Effective Date**

First day of the first full calendar year that is twelve months beyond the date that this standard is approved by applicable regulatory authorities, or in those jurisdictions where regulatory approval is not required, the standard becomes effective on the first day of the first full calendar year that is twelve months beyond the date this standard is approved by the NERC Board of Trustees, or as otherwise made effective pursuant to the laws applicable to such ERO governmental authorities.

**Justification**

The implementation plan based on the general considerations above provides a minimum of one full calendar year for the Generator Owner, Planning Coordinator, Reliability Coordinator, Transmission Owner, and Transmission Planner to begin the annual cycle of becoming compliant with standard regardless of the approval timing by the applicable NERC Board of Trustees or ERO governmental authorities. For example, if the standard is adopted or approved on September 1, 2015, the standard would become effective on January 1, 2017.

## Unofficial Comment Form

### Project 2010-13.3 – Relay Loadability: Stable Power Swings

Please **DO NOT** use this form for submitting comments. Please use the [electronic form](#) to submit comments on the Standard. The electronic comment form must be completed by 8 p.m. Eastern Monday, June 9, 2014.

If you have questions please contact [Scott Barfield-McGinnis](#), Standards Developer via email or by telephone at (404) 446-9689.

The project page may be accessed by clicking [here](#)

#### **Background Information**

This posting is soliciting formal comment.

This is Phase 3 of a three-phased standard development that is focused on developing a new Reliability Standard, PRC-026-1 – Relay Performance During Stable Power Swings, to address protective relay operations due to stable power swings. The March 18, 2010, FERC Order No. 733, approved Reliability Standard PRC-023-1 – Transmission Relay Loadability. In this Order, FERC directed NERC to address three areas of relay loadability that include modifications to the approved PRC-023-1, development of a new Reliability Standard to address generator protective relay loadability, and a new Reliability Standard to address the operation of protective relays due to stable power swings. This project's SAR addresses these directives with a three-phased approach to standard development.

Phase 1 focused on making the specific modifications to PRC-023-1 and was completed in the approved Reliability Standard PRC-023-2, which became mandatory on July 1, 2012. Phase 2 focused on developing a new Reliability Standard, PRC-025-1 – Generator Relay Loadability, to address generator protective relay loadability; Phase 2 is currently awaiting regulatory approval. This Phase 3 of the project focuses on developing a new Reliability Standard, PRC-026-1 – Relay Performance During Stable Power Swings, to address protective relay operations due to stable power swings. This Reliability Standard will establish requirements aimed at preventing protective relays from tripping unnecessarily due to stable power swings by requiring the Transmission Owners and Generator Owners to assess the security of protective relay systems that are susceptible to operation during power swings, and take actions to improve security for stable power swings where such actions would not compromise dependable operation for faults and unstable power swings.

You do not have to answer all questions. Enter comments in simple text format. Bullets, numbers, and special formatting will not be retained.

*\*Please use the [electronic comment form](#) to submit your final comments to NERC.*

**You do not have to answer all questions. Enter All Comments in Simple Text Format.**

Please note that the official comment form **does not** retain formatting (even if it appears to transfer formatting when you copy from the unofficial Word version of the form into the official electronic comment form). If you enter extra carriage returns, bullets, automated numbering, symbols, bolding, italics, or any other formatting, that formatting will not be retained when you submit your comments.

- Separate discrete comments by idea, e.g., preface with (1), (2), etc.
- Use brackets [] to call attention to suggested inserted or deleted text.
- Insert a “check” mark in the appropriate boxes by double-clicking the gray areas.
- **Do not use** formatting such as extra carriage returns, bullets, automated numbering, bolding, or italics.
- **Please do not repeat other entity’s comments.** Select the appropriate item to support another entity’s comments. An opportunity to enter additional or exception comments will be available.
- If supporting other’s comments, be sure the other party submits comments.

**Questions**

1. Do you agree with the focused approach using the criteria (see R1 & R2) which came from recommendations in the PSRPS technical document<sup>1</sup> (pg. 21 of 61)? If not, please explain why or why not (e.g., the approach should be more narrow or more broad, and if so, the basis for a different approach).

Yes

No

Comments:

---

<sup>1</sup> NERC System Protection and Control Subcommittee, Protection System Response to Power Swings, August 2013  
[http://www.nerc.com/comm/PC/System%20Protection%20and%20Control%20Subcommittee%20SPCS%2020/SPCS%20Power%20Swing%20Report\\_Final\\_20131015.pdf](http://www.nerc.com/comm/PC/System%20Protection%20and%20Control%20Subcommittee%20SPCS%2020/SPCS%20Power%20Swing%20Report_Final_20131015.pdf)



2. Do you agree that the Planning Coordinator, Reliability Coordinator, and Transmission Planner are the appropriate entities to identify the Elements that meet the criteria in Requirement R1? If not, please explain why an entity is not appropriate and/or suggest an alternative that should identify the Elements according to the criteria.

Yes

No

Comments:

3. Do you agree that the Generator Owner and Transmission Owner are the appropriate entities to identify the Elements that meet the criteria in Requirement R2? If not, please explain why an entity is not appropriate and/or suggest an alternative that should identify the Elements according to the criteria.

Yes

No

Comments:

4. Do you agree with the approach in Requirement R3 to ensure that load-responsive protective relays do not trip in response to stable power swings during non-Fault conditions for an identified Element? If not, please explain.

Yes

No

Comments:

5. Do you agree with the proposed Violation Risk Factors (VRF) and Violation Severity Levels (VSL) for the proposed requirements? If not, please provide a basis for revising a VRF and/or what would improve the clarity of the VSLs.

Yes

No

Comments:

6. Does PRC-026-1, Application Guidelines and Technical Basis provide sufficient guidance, basis for approach, and examples to support performance of the requirements? If not, please provide specific detail that would improve the Guidelines and Technical Basis.

Yes

No

Comments:

7. Do you agree with implementation period of the proposed standard based on the considerations listed in the Implementation Plan? If not, please provide a justification for changing the proposed implementation period.

Yes

No

Comments:

8. If you are aware of any conflicts between the proposed standard and any regulatory function, rule, order, tariff, rate schedule, legislative requirement, or agreement please identify the conflict here:

Yes

No

Comments:

9. If you are aware of the need for a regional variance or business practice that should be considered with this phase of the project, please identify it here:

Yes

No

Comments:

10. If you have any other comments on this Standard that you haven't already mentioned above, please provide them here:

Comments:

# Violation Risk Factors and Violation Severity Level Justifications

Project 2010-13.3 – Relay Loadability: Stable Power Swings  
(PRC-026-1 – Relay Performance During Stable Power Swings)

## Violation Risk Factor and Violation Severity Level Justifications

This document provides the drafting team's justification for assignment of violation risk factors (VRFs) and violation severity levels (VSLs) for each requirement in: PRC-004-3 — Protection System Misoperations.

Each primary requirement is assigned a VRF and a set of one or more VSLs. These elements support the determination of an initial value range for the Base Penalty Amount regarding violations of requirements in FERC-approved Reliability Standards, as defined in the ERO Sanction Guidelines.

The Protection System Misoperations Standard Drafting Team applied the following NERC criteria and FERC Guidelines when proposing VRFs and VSLs for the requirements under this project.

### **NERC Criteria - Violation Risk Factors**

#### ***High Risk Requirement***

A requirement that, if violated, could directly cause or contribute to bulk electric system instability, separation, or a cascading sequence of failures, or could place the bulk electric system at an unacceptable risk of instability, separation, or cascading failures; or, a requirement in a planning time frame that, if violated, could, under emergency, abnormal, or restorative conditions anticipated by the preparations, directly cause or contribute to bulk electric system instability, separation, or a cascading sequence of failures, or could place the bulk electric system at an unacceptable risk of instability, separation, or cascading failures, or could hinder restoration to a normal condition.

#### ***Medium Risk Requirement***

A requirement that, if violated, could directly affect the electrical state or the capability of the bulk electric system, or the ability to effectively monitor and control the bulk electric system. However, violation of a medium risk requirement is unlikely to lead to bulk electric system instability, separation, or cascading failures; or, a requirement in a planning time frame that, if violated, could, under emergency, abnormal, or restorative conditions anticipated by the preparations, directly and adversely affect the electrical state or capability of the bulk electric system, or the ability to effectively monitor, control, or restore the bulk electric system.

However, violation of a medium risk requirement is unlikely, under emergency, abnormal, or restoration conditions anticipated by the preparations, to lead to bulk electric system instability, separation, or cascading failures, nor to hinder restoration to a normal condition.

### ***Lower Risk Requirement***

A requirement that is administrative in nature and a requirement that, if violated, would not be expected to adversely affect the electrical state or capability of the bulk electric system, or the ability to effectively monitor and control the bulk electric system; or, a requirement that is administrative in nature and a requirement in a planning time frame that, if violated, would not, under the emergency, abnormal, or restorative conditions anticipated by the preparations, be expected to adversely affect the electrical state or capability of the bulk electric system, or the ability to effectively monitor, control, or restore the bulk electric system. A planning requirement that is administrative in nature.

### **FERC Violation Risk Factor Guidelines**

The standard drafting team (SDT) also considered consistency with the FERC Violation Risk Factor Guidelines for setting VRFs:<sup>1</sup>

#### **Guideline (1) — Consistency with the Conclusions of the Final Blackout Report**

The Commission seeks to ensure that Violation Risk Factors assigned to Requirements of Reliability Standards in these identified areas appropriately reflect their historical critical impact on the reliability of the Bulk-Power System.

In the VSL Order, FERC listed critical areas (from the Final Blackout Report) where violations could severely affect the reliability of the Bulk-Power System:<sup>2</sup>

- Emergency operations
- Vegetation management
- Operator personnel training
- Protection systems and their coordination
- Operating tools and backup facilities
- Reactive power and voltage control
- System modeling and data exchange
- Communication protocol and facilities
- Requirements to determine equipment ratings
- Synchronized data recorders
- Clearer criteria for operationally critical facilities
- Appropriate use of transmission loading relief

#### **Guideline (2) — Consistency within a Reliability Standard**

<sup>1</sup> North American Electric Reliability Corp., 119 FERC ¶ 61,145, order on reh'g and compliance filing, 120 FERC ¶ 61,145 (2007) ("VRF Rehearing Order").

<sup>2</sup> Id. at footnote 15.

The Commission expects a rational connection between the sub-Requirement Violation Risk Factor assignments and the main Requirement Violation Risk Factor assignment.

**Guideline (3) – Consistency among Reliability Standards**

The Commission expects the assignment of Violation Risk Factors corresponding to Requirements that address similar reliability goals in different Reliability Standards would be treated comparably.

**Guideline (4) – Consistency with NERC’s Definition of the Violation Risk Factor Level**

Guideline (4) was developed to evaluate whether the assignment of a particular Violation Risk Factor level conforms to NERC’s definition of that risk level.

**Guideline (5) – Treatment of Requirements that Co-mingle More Than One Obligation**

Where a single Requirement co-mingles a higher risk reliability objective and a lesser risk reliability objective, the VRF assignment for such Requirements must not be watered down to reflect the lower risk level associated with the less important objective of the Reliability Standard.

**NERC Criteria - Violation Severity Levels**

Violation Severity Levels (VSLs) define the degree to which compliance with a requirement was not achieved. Each requirement must have at least one VSL. While it is preferable to have four VSLs for each requirement, some requirements do not have multiple “degrees” of noncompliant performance and may have only one, two, or three VSLs.

Violation severity levels should be based on the guidelines shown in the table below:

Lower	Moderate	High	Severe
Missing a minor element (or a small percentage) of the required performance The performance or product measured has significant value as it almost meets the full intent of the requirement.	Missing at least one significant element (or a moderate percentage) of the required performance. The performance or product measured still has significant value in meeting the intent of the requirement.	Missing more than one significant element (or is missing a high percentage) of the required performance or is missing a single vital component. The performance or product has limited value in meeting the intent of the requirement.	Missing most or all of the significant elements (or a significant percentage) of the required performance. The performance measured does not meet the intent of the requirement or the product delivered cannot be used in meeting the intent of the requirement.

***FERC Order on Violation Severity Levels***

In its June 19, 2008 Order on Violation Severity Levels, FERC indicated it would use the following four guidelines for determining whether to approve VSLs:

***Guideline 1: Violation Severity Level Assignments Should Not Have the Unintended Consequence of Lowering the Current Level of Compliance***

Compare the VSLs to any prior Levels of Non-compliance and avoid significant changes that may encourage a lower level of compliance than was required when Levels of Non-compliance were used.

***Guideline 2: Violation Severity Level Assignments Should Ensure Uniformity and Consistency in the Determination of Penalties***

Guideline 2a: A violation of a “binary” type requirement must be a “Severe” VSL.

Guideline 2b: Do not use ambiguous terms such as “minor” and “significant” to describe noncompliant performance.

***Guideline 3: Violation Severity Level Assignment Should Be Consistent with the Corresponding Requirement***

VSLs should not expand on what is required in the requirement.

***Guideline 4: Violation Severity Level Assignment Should Be Based on A Single Violation, Not on A Cumulative Number of Violations***

. . . unless otherwise stated in the requirement, each instance of non-compliance with a requirement is a separate violation. Section 4 of the Sanction Guidelines states that assessing penalties on a per violation per day basis is the “default” for penalty calculations.

VRF and VSL Justifications – PRC-026-1, R1

Proposed VRF	Medium
NERC VRF Discussion	<p>A Violation Risk Factor of Medium is consistent with the NERC VRF Guidelines:</p> <p>A failure to identify an Element meeting the criteria prohibits further evaluation of any load-responsive protective relay applied at the terminal of the Element. A load-responsive protective relay that goes without evaluation may not be secure for a stable power swing and could in the planning time frame, under emergency, abnormal, or restorative conditions anticipated by the preparations, directly and adversely affect the electrical state or capability of the bulk electric system, or the ability to effectively monitor, control, or restore the bulk electric system. However, violation of a medium risk requirement is unlikely, under emergency, abnormal, or restoration conditions anticipated by the preparations, to lead to bulk electric system instability, separation, or cascading failures, nor to hinder restoration to a normal condition.</p> <p>Identifying an Element that is expected to encounter stable power swings based on prescribed criteria is the first step in ensuring the reliable operation of the BES and in preventing the future severity of Disturbances from affecting a wider area. However, violation of this requirement is unlikely to under emergency, abnormal, or restorative conditions anticipated by the preparations, directly cause or contribute to bulk electric system instability, separation, or a cascading sequence of failures, or could place the bulk electric system at an unacceptable risk of instability, separation, or cascading failures, or could hinder restoration to a normal condition.</p>
FERC VRF G1 Discussion	<p>Guideline 1- Consistency w/ Blackout Report:</p> <p>The blackout report and subsequent technical analysis identified that two BPS transmission lines tripped due to protective relay operation in response to stable power swings. The protection system operations on these lines did not contribute significantly to the overall outcome of the August 14, 2003 system disturbance; however, protection system operation during stable powers swings could negatively impact system reliability under different operating conditions. Identifying Elements prone to power swings and the subsequent mitigation of load-responsive protective relays applied at the terminals of these Elements will reduce the likelihood of reoccurrence. This requirement is consistent with the intent of Recommendation 8: Improve System Protection to Slow or Limit the Spread of Future Cascading Outages. While the actions associated with this recommendation did not focus specifically on this issue, the recommendation does note that “power system protection devices should be set to address the specific</p>

VRF and VSL Justifications – PRC-026-1, R1	
	condition of concern, such as a fault, out-of-step condition, etc., and should not compromise a power system’s inherent physical capability to slow down or stop a cascading event.”
FERC VRF G2 Discussion	Guideline 2- Consistency within a Reliability Standard: The requirement has a single reliability activity associated with the reliability objective and no sub-Requirement(s) which allows a single VRF to be assigned; therefore no conflict(s) exist.
FERC VRF G3 Discussion	Guideline 3- Consistency among Reliability Standards: The requirement is consistent with Reliability Standards FAC-014-2, R6 (“...Planning Authority shall identify the subset of multiple contingencies...”) which has a VRF of Medium.
FERC VRF G4 Discussion	Guideline 4- Consistency with NERC Definitions of VRFs: A failure to identify an Element meeting the criteria prohibits further evaluation of any load-responsive protective relay applied at the terminal of the Element. A load-responsive protective relay that goes without evaluation may not be secure for a stable power swing and could in the planning time frame, under emergency, abnormal, or restorative conditions anticipated by the preparations, directly and adversely affect the electrical state or capability of the bulk electric system, or the ability to effectively monitor, control, or restore the bulk electric system. However, violation of a medium risk requirement is unlikely, under emergency, abnormal, or restoration conditions anticipated by the preparations, to lead to bulk electric system instability, separation, or cascading failures, nor to hinder restoration to a normal condition. Identifying an Element that is expected to encounter stable power swings based on prescribed criteria is the first step in ensuring the reliable operation of the BES and in preventing the future severity of Disturbances from affecting a wider area. However, violation of this requirement is unlikely to under emergency, abnormal, or restorative conditions anticipated by the preparations, directly cause or contribute to bulk electric system instability, separation, or a cascading sequence of failures, or could place the bulk electric system at an unacceptable risk of instability, separation, or cascading failures, or could hinder restoration to a normal condition.
FERC VRF G5 Discussion	Guideline 5- Treatment of Requirements that Co-mingle More than One Obligation: This requirement does not co-mingle reliability objectives of differing risk; therefore, the assigned VRF of Medium is consistent.



VRF and VSL Justifications – PRC-026-1, R1			
Proposed VSL			
Lower	Moderate	High	Severe
The responsible entity identified an Element and provided notification in accordance with Requirement R1, but was less than or equal to 30 calendar days late.	The responsible entity identified an Element and provided notification in accordance with Requirement R1, but was more than 30 calendar days and less than or equal to 60 calendar days late.	The responsible entity identified an Element and provided notification in accordance with Requirement R1, but was more than 60 calendar days and less than or equal to 90 calendar days late.	The responsible entity identified an Element and provided notification in accordance with Requirement R1, but was more than 90 calendar days late. OR The responsible entity failed to identify an Element or to provide notification in accordance with Requirement R1.
NERC VSL Guidelines	Meets NERC’s VSL Guidelines—There is an incremental aspect to the VSL for tardiness and a binary aspect for failure. The VSL is entity size-neutral because performance is Element-driven and not by the total assets which an entity may have awareness over.		
FERC VSL G1 Violation Severity Level Assignments Should Not Have the Unintended Consequence of Lowering the Current Level of Compliance	The proposed VSL does not lower the current level of compliance because the requirement is new.		
FERC VSL G2 Violation Severity Level Assignments Should Ensure Uniformity and Consistency in the Determination of Penalties	<p>Guideline 2a: This requirement is not binary; therefore, this criterion does not apply.</p> <p>Guideline 2b: The proposed VSL does not use any ambiguous terminology, thereby supporting uniformity and consistency in the determination of similar penalties for similar violations.</p>		

VRF and VSL Justifications – PRC-026-1, R1	
Guideline 2a: The Single Violation Severity Level Assignment Category for "Binary" Requirements Is Not Consistent Guideline 2b: Violation Severity Level Assignments that Contain Ambiguous Language	
FERC VSL G3 Violation Severity Level Assignment Should Be Consistent with the Corresponding Requirement	The proposed VSL uses similar terminology to that used in the corresponding requirement, and is therefore consistent with the requirement.
FERC VSL G4 Violation Severity Level Assignment Should Be Based on A Single Violation, Not on A Cumulative Number of Violations	The VSL is based on a single violation and not cumulative violations.

VRF and VSL Justifications – PRC-026-1, R2	
<b>Proposed VRF</b>	<b>Medium</b>
NERC VRF Discussion	A Violation Risk Factor of Medium is consistent with the NERC VRF Guidelines: A failure to identify an Element meeting the criteria prohibits further evaluation of any load-responsive protective relay applied at the terminal of the Element. A load-responsive protective relay that goes without evaluation may not be secure for a stable power swing and could in the planning time frame, under emergency, abnormal, or restorative conditions anticipated by the preparations, directly and

VRF and VSL Justifications – PRC-026-1, R2

	<p>adversely affect the electrical state or capability of the bulk electric system, or the ability to effectively monitor, control, or restore the bulk electric system. However, violation of a medium risk requirement is unlikely, under emergency, abnormal, or restoration conditions anticipated by the preparations, to lead to bulk electric system instability, separation, or cascading failures, nor to hinder restoration to a normal condition.</p> <p>Identifying an Element that is expected to encounter stable power swings based on prescribed criteria is the first step in ensuring the reliable operation of the BES and in preventing the future severity of Disturbances from affecting a wider area. However, violation of this requirement is unlikely to under emergency, abnormal, or restorative conditions anticipated by the preparations, directly cause or contribute to bulk electric system instability, separation, or a cascading sequence of failures, or could place the bulk electric system at an unacceptable risk of instability, separation, or cascading failures, or could hinder restoration to a normal condition.</p>
<p>FERC VRF G1 Discussion</p>	<p>Guideline 1- Consistency w/ Blackout Report:          The blackout report and subsequent technical analysis identified that two BPS transmission lines tripped due to protective relay operation in response to stable power swings. The protection system operations on these lines did not contribute significantly to the overall outcome of the August 14, 2003 system disturbance; however, protection system operation during stable powers swings could negatively impact system reliability under different operating conditions. Identifying Elements prone to power swings and the subsequent mitigation of load-responsive protective relays applied at the terminals of these Elements will reduce the likelihood of reoccurrence. This requirement is consistent with the intent of Recommendation 8: Improve System Protection to Slow or Limit the Spread of Future Cascading Outages. While the actions associated with this recommendation did not focus specifically on this issue, the recommendation does note that “power system protection devices should be set to address the specific condition of concern, such as a fault, out-of-step condition, etc., and should not compromise a power system’s inherent physical capability to slow down or stop a cascading event.”</p>
<p>FERC VRF G2 Discussion</p>	<p>Guideline 2- Consistency within a Reliability Standard:          The requirement has a single reliability activity associated with the reliability objective and no sub-Requirement(s) which allows a single VRF to be assigned; therefore no conflict(s) exist.</p>

VRF and VSL Justifications – PRC-026-1, R2

<p>FERC VRF G3 Discussion</p>	<p>Guideline 3- Consistency among Reliability Standards:                  The requirement is consistent with Reliability Standards FAC-014-2, R6 (“...Planning Authority shall identify the subset of multiple contingencies...”) which has a VRF of Medium.</p>
<p>FERC VRF G4 Discussion</p>	<p>Guideline 4- Consistency with NERC Definitions of VRFs:                  A failure to identify an Element meeting the criteria prohibits further evaluation of any load-responsive protective relay applied at the terminal of the Element. A load-responsive protective relay that goes without evaluation may not be secure for a stable power swing and could in the planning time frame, under emergency, abnormal, or restorative conditions anticipated by the preparations, directly and adversely affect the electrical state or capability of the bulk electric system, or the ability to effectively monitor, control, or restore the bulk electric system. However, violation of a medium risk requirement is unlikely, under emergency, abnormal, or restoration conditions anticipated by the preparations, to lead to bulk electric system instability, separation, or cascading failures, nor to hinder restoration to a normal condition.                  Identifying an Element that is expected to encounter stable power swings based on prescribed criteria is the first step in ensuring the reliable operation of the BES and in preventing the future severity of Disturbances from affecting a wider area. However, violation of this requirement is unlikely to under emergency, abnormal, or restorative conditions anticipated by the preparations, directly cause or contribute to bulk electric system instability, separation, or a cascading sequence of failures, or could place the bulk electric system at an unacceptable risk of instability, separation, or cascading failures, or could hinder restoration to a normal condition.</p>
<p>FERC VRF G5 Discussion</p>	<p>Guideline 5- Treatment of Requirements that Co-mingle More than One Obligation:                  This requirement does not co-mingle reliability objectives of differing risk; therefore, the assigned VRF of Medium is consistent.</p>

VRF and VSL Justifications – PRC-026-1, R2			
Proposed VSL			
Lower	Moderate	High	Severe
The responsible entity identified Element in accordance with Requirement R2, but was less than or equal to 30 calendar days late.	The responsible entity identified Element in accordance with Requirement R2, but was more than 30 calendar days and less than or equal to 60 calendar days late.	The responsible entity identified Element in accordance with Requirement R2, but was more than 60 calendar days and less than or equal to 90 calendar days late.	The responsible entity identified Element in accordance with Requirement R2, but was more than 90 calendar days late. OR The responsible entity failed to identify an Element in accordance with Requirement R2.
NERC VSL Guidelines	Meets NERC’s VSL Guidelines—There is an incremental aspect to the VSL for tardiness and a binary aspect for failure. The VSL is entity size-neutral because performance is Element-driven and not by the total assets which an entity may have awareness over.		
FERC VSL G1 Violation Severity Level Assignments Should Not Have the Unintended Consequence of Lowering the Current Level of Compliance	The proposed VSL does not lower the current level of compliance because the requirement is new.		
FERC VSL G2 Violation Severity Level Assignments Should Ensure Uniformity and Consistency in the Determination of Penalties Guideline 2a: The Single Violation Severity Level Assignment Category for	<p>Guideline 2a: This requirement is not binary; therefore, this criterion does not apply.</p> <p>Guideline 2b: The proposed VSL does not use any ambiguous terminology, thereby supporting uniformity and consistency in the determination of similar penalties for similar violations.</p>		

VRF and VSL Justifications – PRC-026-1, R2	
"Binary" Requirements Is Not Consistent Guideline 2b: Violation Severity Level Assignments that Contain Ambiguous Language	
FERC VSL G3 Violation Severity Level Assignment Should Be Consistent with the Corresponding Requirement	The proposed VSL uses similar terminology to that used in the corresponding requirement, and is therefore consistent with the requirement.
FERC VSL G4 Violation Severity Level Assignment Should Be Based on A Single Violation, Not on A Cumulative Number of Violations	The VSL is based on a single violation and not cumulative violations.

VRF and VSL Justifications – PRC-026-1, R3	
<b>Proposed VRF</b>	<b>Medium</b>
NERC VRF Discussion	A Violation Risk Factor of Medium is consistent with the NERC VRF Guidelines: A failure to ensure the Protection System will not trip in response to a stable power swing for an identified Element could in the planning time frame, under emergency, abnormal, or restorative conditions anticipated by the preparations, directly and adversely affect the electrical state or capability of the bulk electric system, or the ability to effectively monitor, control, or restore the bulk electric system. However, violation of a medium risk requirement is unlikely, under emergency, abnormal, or restoration conditions anticipated by the preparations, to lead to bulk electric system instability, separation, or cascading failures, nor to hinder restoration to a normal condition.

VRF and VSL Justifications – PRC-026-1, R3	
	If a Protection System is less secure during stable power swings, it increases the risk of tripping should the Protection System be challenged by a power swing; However, violation of this requirement is unlikely to lead to bulk electric system instability, separation, or cascading failures.
FERC VRF G1 Discussion	<p>Guideline 1- Consistency w/ Blackout Report:</p> <p>The blackout report and subsequent technical analysis identified that two BPS transmission lines tripped due to protective relay operation in response to stable power swings. The protection system operations on these lines did not contribute significantly to the overall outcome of the August 14, 2003 system disturbance; however, protection system operation during stable powers swings could negatively impact system reliability under different operating conditions. Identifying Elements prone to power swings and the subsequent mitigation of load-responsive protective relays applied at the terminals of these Elements will reduce the likelihood of reoccurrence. This requirement is consistent with the intent of Recommendation 8: Improve System Protection to Slow or Limit the Spread of Future Cascading Outages. While the actions associated with this recommendation did not focus specifically on this issue, the recommendation does note that “power system protection devices should be set to address the specific condition of concern, such as a fault, out-of-step condition, etc., and should not compromise a power system’s inherent physical capability to slow down or stop a cascading event.”</p>
FERC VRF G2 Discussion	<p>Guideline 2- Consistency within a Reliability Standard:</p> <p>The requirement has a single reliability activity associated with the reliability objective and no sub-Requirement(s) which allows a single VRF to be assigned; therefore no conflict(s) exist.</p>
FERC VRF G3 Discussion	<p>Guideline 3- Consistency among Reliability Standards:</p> <p>This requirement is consistent with Reliability Standard FAC-002-1, R1.3 (“...Evidence that the parties involved in the assessment have coordinated and cooperated on...”) which has a VRF of Medium.</p>
FERC VRF G4 Discussion	<p>Guideline 4- Consistency with NERC Definitions of VRFs:</p> <p>A failure to ensure the Protection System will not trip in response to a stable power swing for an identified Element could in the planning time frame, under emergency, abnormal, or restorative conditions anticipated by the preparations, directly and adversely affect the electrical state or capability of the bulk electric system, or the ability to effectively monitor, control, or restore the bulk electric system. However, violation of a medium risk requirement is unlikely, under emergency, abnormal, or restoration conditions</p>

VRF and VSL Justifications – PRC-026-1, R3			
	<p>anticipated by the preparations, to lead to bulk electric system instability, separation, or cascading failures, nor to hinder restoration to a normal condition.</p> <p>If a Protection System is less secure during stable power swings, it increases the risk of tripping should the Protection System be challenged by a power swing; However, violation of this requirement is unlikely to lead to bulk electric system instability, separation, or cascading failures.</p>		
FERC VRF G5 Discussion	<p>Guideline 5- Treatment of Requirements that Co-mingle More than One Obligation: This requirement does not co-mingle reliability objectives of differing risk; therefore, the assigned VRF of Medium is consistent.</p>		
Proposed VSL			
Lower	Moderate	High	Severe
<p>The responsible entity performed one of the options in accordance with Requirement R3, but was less than or equal to 30 calendar days late.</p>	<p>The responsible entity performed one of the options in accordance with Requirement R3, but was more than 30 calendar days and less than or equal to 60 calendar days late.</p>	<p>The responsible entity performed one of the options in accordance with Requirement R3, but was more than 60 calendar days and less than or equal to 90 calendar days late.</p>	<p>The responsible entity performed one of the options in accordance with Requirement R3, but was more than 90 calendar days late. OR The responsible entity failed to perform one of the options in accordance with Requirement R3.</p>
NERC VSL Guidelines	<p>Meets NERC’s VSL Guidelines—There is an incremental aspect to the VSL for tardiness and a binary aspect for failure. The VSL is entity size-neutral because performance is driven by exception. For example, each Element that requires further review must be provided to the Transmission Planner for simulation to determine the apparent impedance characteristics.</p>		
FERC VSL G1 Violation Severity Level Assignments Should Not Have the Unintended Consequence	<p>The proposed VSL does not lower the current level of compliance because the requirement is new.</p>		



VRF and VSL Justifications – PRC-026-1, R3	
of Lowering the Current Level of Compliance	
<p>FERC VSL G2 Violation Severity Level Assignments Should Ensure Uniformity and Consistency in the Determination of Penalties</p> <p>Guideline 2a: The Single Violation Severity Level Assignment Category for "Binary" Requirements Is Not Consistent</p> <p>Guideline 2b: Violation Severity Level Assignments that Contain Ambiguous Language</p>	<p>Guideline 2a: This requirement is not binary; therefore, this criterion does not apply.</p> <p>Guideline 2b: The proposed VSL does not use any ambiguous terminology, thereby supporting uniformity and consistency in the determination of similar penalties for similar violations.</p>
<p>FERC VSL G3 Violation Severity Level Assignment Should Be Consistent with the Corresponding Requirement</p>	<p>The proposed VSL uses similar terminology to that used in the corresponding requirement, and is therefore consistent with the requirement.</p>
<p>FERC VSL G4 Violation Severity Level Assignment Should Be Based on A Single Violation, Not on A Cumulative Number of Violations</p>	<p>The VSL is based on a single violation and not cumulative violations.</p>

VRF and VSL Justifications – PRC-026-1, R4

Proposed VRF	Medium
NERC VRF Discussion	<p>A Violation Risk Factor of Medium is consistent with the NERC VRF Guidelines:            A failure to implement the Corrective Action Plan for a Protection System of an identified Element could in the planning time frame, under emergency, abnormal, or restorative conditions anticipated by the preparations, directly and adversely affect the electrical state or capability of the bulk electric system, or the ability to effectively monitor, control, or restore the bulk electric system. However, violation of a medium risk requirement is unlikely, under emergency, abnormal, or restoration conditions anticipated by the preparations, to lead to bulk electric system instability, separation, or cascading failures, nor to hinder restoration to a normal condition.</p> <p>An unmitigated Protection System could contribute to the severity of future disturbances affecting a wider area, or potential equipment damage. However, violation of this requirement is unlikely to lead to bulk electric system instability, separation, or cascading failures.</p>
FERC VRF G1 Discussion	<p>Guideline 1- Consistency w/ Blackout Report:            The blackout report and subsequent technical analysis identified that two BPS transmission lines tripped due to protective relay operation in response to stable power swings. The protection system operations on these lines did not contribute significantly to the overall outcome of the August 14, 2003 system disturbance; however, protection system operation during stable powers swings could negatively impact system reliability under different operating conditions. Identifying Elements prone to power swings and the subsequent mitigation of load-responsive protective relays applied at the terminals of these Elements will reduce the likelihood of reoccurrence. This requirement is consistent with the intent of Recommendation 8: Improve System Protection to Slow or Limit the Spread of Future Cascading Outages. While the actions associated with this recommendation did not focus specifically on this issue, the recommendation does note that “power system protection devices should be set to address the specific condition of concern, such as a fault, out-of-step condition, etc., and should not compromise a power system’s inherent physical capability to slow down or stop a cascading event.”</p>
FERC VRF G2 Discussion	<p>Guideline 2- Consistency within a Reliability Standard:            The requirement has a single reliability activity associated with the reliability objective and no sub-Requirement(s) which allows a single VRF to be assigned; therefore no conflict(s) exist.</p>

VRF and VSL Justifications – PRC-026-1, R4			
FERC VRF G3 Discussion	<p>Guideline 3- Consistency among Reliability Standards:                      The requirement is consistent with Reliability Standards PRC-016-0.1, R2 (“...shall take corrective actions to avoid future Misoperations”), PRC-022-1, R1.5 (“For any Misoperation, a Corrective Action Plan...”), FAC-003, R5 (“...Transmission Owner or applicable Generator Owner shall take corrective action to ensure continued vegetation management”) all of which have a VRF of Medium.</p>		
FERC VRF G4 Discussion	<p>A Violation Risk Factor of Medium is consistent with the NERC VRF Guidelines:                      A failure to implement the Corrective Action Plan for a Protection System of an identified Element could in the planning time frame, under emergency, abnormal, or restorative conditions anticipated by the preparations, directly and adversely affect the electrical state or capability of the bulk electric system, or the ability to effectively monitor, control, or restore the bulk electric system. However, violation of a medium risk requirement is unlikely, under emergency, abnormal, or restoration conditions anticipated by the preparations, to lead to bulk electric system instability, separation, or cascading failures, nor to hinder restoration to a normal condition.                      An unmitigated Protection System could contribute to the severity of future disturbances affecting a wider area, or potential equipment damage. However, violation of this requirement is unlikely to lead to bulk electric system instability, separation, or cascading failures.</p>		
FERC VRF G5 Discussion	<p>Guideline 5- Treatment of Requirements that Co-mingle More than One Obligation:                      This requirement does not co-mingle reliability objectives of differing risk; therefore, the assigned VRF of Medium is consistent.</p>		
Proposed VSL			
Lower	Moderate	High	Severe
The responsible entity implemented, but failed to update a CAP, when actions or timetables changed, in accordance with Requirement R4.	N/A	N/A	The responsible entity failed to implement a CAP in accordance with Requirement R4.

VRF and VSL Justifications – PRC-026-1, R4

VRF and VSL Justifications – PRC-026-1, R4	
NERC VSL Guidelines	Meets NERC’s VSL Guidelines—There is an incremental aspect to the VSL for tardiness and a binary aspect for failure. The VSL is entity size-neutral because performance is driven by exception. For example, each Element that requires further review must be provided to the Transmission Planner for simulation to determine the apparent impedance characteristics.
FERC VSL G1 Violation Severity Level Assignments Should Not Have the Unintended Consequence of Lowering the Current Level of Compliance	The proposed VSL does not lower the current level of compliance because the requirement is new.
FERC VSL G2 Violation Severity Level Assignments Should Ensure Uniformity and Consistency in the Determination of Penalties Guideline 2a: The Single Violation Severity Level Assignment Category for "Binary" Requirements Is Not Consistent Guideline 2b: Violation Severity Level Assignments that Contain Ambiguous Language	Guideline 2a: This requirement is not binary; therefore, this criterion does not apply.  Guideline 2b: The proposed VSL does not use any ambiguous terminology, thereby supporting uniformity and consistency in the determination of similar penalties for similar violations.
FERC VSL G3 Violation Severity Level Assignment Should Be	The proposed VSL uses similar terminology to that used in the corresponding requirement, and is therefore consistent with the requirement.

**VRF and VSL Justifications – PRC-026-1, R4**

<p>Consistent with the Corresponding Requirement</p>	
<p>FERC VSL G4 Violation Severity Level Assignment Should Be Based on A Single Violation, Not on A Cumulative Number of Violations</p>	<p>The VSL is based on a single violation and not cumulative violations.</p>

## Table of Issues and Directives

### Project 2010-13.3 – Relay Loadability: Stable Power Swings

Table of Issues and Directives Associated with PRC-026-1

Source	Issue or Directive Language (including Para. #)	Section and/or Requirement(s)	Consideration of Issue or Directive
FERC Order 733	<b>150.</b> We will not direct the ERO to modify PRC-023-1 to address stable power swings. However, because both NERC and the Task Force have identified undesirable relay operation due to stable power swings as a reliability issue, we direct the ERO to develop a Reliability Standard that requires the use of protective relay systems that can differentiate between faults and stable power swings and, when necessary, phases out protective	All requirements	<p>The PRC-026-1 standard is responsive to this directive because it applies a focused approach to identify BES Elements according to Requirement R1 for the Planning Coordinator, Reliability Coordinator, and Transmission Planner. Similarly in Requirement R2 for the Generator Owner and Transmission Owner. The criterion used to identify a BES Element is based on the PSRPS technical document (“PSRPS Report”).<sup>1</sup></p> <p>Requirement R3 is responsive to the directive by requiring the Generator Owner and Transmission Owner to perform one of the listed options in Requirement R3.</p>

<sup>1</sup> NERC System Protection and Control Subcommittee technical document, *Protection System Response to Power Swings*, August 2013: [http://www.nerc.com/comm/PC/System%20Protection%20and%20Control%20Subcommittee%20SPCS%2020/SPCS%20Power%20Swing%20Report\\_Final\\_20131015.pdf](http://www.nerc.com/comm/PC/System%20Protection%20and%20Control%20Subcommittee%20SPCS%2020/SPCS%20Power%20Swing%20Report_Final_20131015.pdf)

Table of Issues and Directives Associated with PRC-026-1

Source	Issue or Directive Language (including Para. #)	Section and/or Requirement(s)	Consideration of Issue or Directive
	<p>relay systems that cannot meet this requirement.</p> <p>We also direct the ERO to file a report no later than 120 days of this Final Rule addressing the issue of protective relay operation due to power swings. The report should include an action plan and timeline that explains how and when the ERO intends to address this issue through its Reliability Standards development process.</p> <p><b>AND</b></p> <p><b>153.</b> While we recognize that addressing stable power swings is a complex issue, we note that more than six years have passed since the August 2003 blackout and there is still no Reliability Standard that addresses relays tripping due to stable power swings. Additionally, NERC has long identified undesirable relay operation</p>		<p>The following is a summary of what each option achieves:</p> <ul style="list-style-type: none"> <li>-Ensures that the Protection System without power swing blocking (PSB) applied is not expected to trip in response to a stable power swing.</li> <li>-Ensures that the Protection System is not expected to trip in response to a stable power swing because (PSB) is applied.</li> <li>-Ensures a Corrective Action Plan (CAP) is developed to modify the Protection System or apply power swing blocking so that the Protection System is not expected to trip in response to a stable power swing.</li> <li>-Ensures that where earlier options do not result in dependable fault detection or dependable out-of-step tripping that the Generator Owner and Transmission Owner: (a) obtain the agreement of the Planning Coordinator, Reliability Coordinator, and Transmission Planner that the existing Protection System design and settings are acceptable, or (b) obtain the agreement of the Planning Coordinator, Reliability Coordinator, and Transmission Planner</li> </ul>

Table of Issues and Directives Associated with PRC-026-1

Source	Issue or Directive Language (including Para. #)	Section and/or Requirement(s)	Consideration of Issue or Directive
	<p>due to stable power swings as a reliability issue. Consequently, pursuant to section 215(d)(5) of the FPA, we find that undesirable relay operation due to stable power swings is a specific matter that the ERO must address to carry out the goals of section 215, and we direct the ERO to develop a Reliability Standard addressing undesirable relay operation due to stable power swings.</p>		<p>that a modification of the Protection System design, settings, or both are acceptable, and develop a CAP to implement the modification.</p> <p>Requirement R4 requires the entity to implement each developed CAP to modify the Protection System.</p>
	<p><b>162.</b> The PSEG Companies also assert that the Commission’s approach to stable power swings should be inclusive and include “islanding” strategies in conjunction with out-of-step blocking or tripping requirements. We agree with the PSEG Companies and direct the ERO to consider “islanding” strategies that achieve the fundamental performance for all islands in</p>	<p>Requirement R1, Criterion 3 and Requirement R2, Criterion 2.</p>	<p>Islanding strategies were considered during the development of the proposed standard. It was determined that consideration of islanding strategies does not comport with the purpose of the proposed standard. The proposed standard’s purpose is to ensure that load-responsive protective relays do not trip in response to stable power swings during non-Fault conditions, not to determine where the transmission system Elements should form island boundaries.</p>



Table of Issues and Directives Associated with PRC-026-1

Source	Issue or Directive Language (including Para. #)	Section and/or Requirement(s)	Consideration of Issue or Directive
	developing the new Reliability Standard addressing stable power swings.		<p>With respect to considering the islanding concern, the proposed standard does require that an Element that was part of a boundary that formed an island since January 1, 2003 be identified as an that is within the scope of the proposed standard.</p> <p>Any identified Element(s) require the Generator Owner and Transmission Owner entities to determine whether its load-responsive protective relays applied at the terminal of such an Element, if any, are susceptible to tripping in response to a stable power swing. If so, the Generator Owner and Transmission Owner is required to take specific action according to the requirements to reduce the risk that its load-responsive protective relays would trip in response to stable power swings during non-Fault conditions.</p>
Issue(s)	None.		

**NERC**

NORTH AMERICAN ELECTRIC  
RELIABILITY CORPORATION

# Protection System Response to Power Swings

System Protection and Control Subcommittee

August 2013

**RELIABILITY | ACCOUNTABILITY**

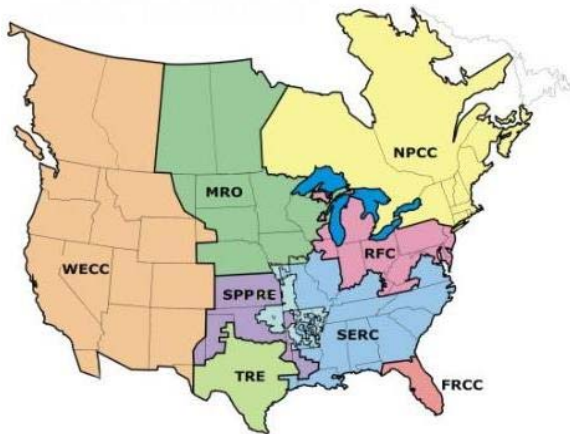


3353 Peachtree Road NE  
Suite 600, North Tower  
Atlanta, GA 30326  
404-446-2560 | [www.nerc.com](http://www.nerc.com)

# NERC's Mission

The North American Electric Reliability Corporation (NERC) is an international regulatory authority established to enhance the reliability of the Bulk-Power System in North America. NERC develops and enforces Reliability Standards; assesses adequacy annually via a ten-year forecast and winter and summer forecasts; monitors the Bulk-Power System; and educates, trains, and certifies industry personnel. NERC is the electric reliability organization for North America, subject to oversight by the U.S. Federal Energy Regulatory Commission (FERC) and governmental authorities in Canada.<sup>1</sup>

NERC assesses and reports on the reliability and adequacy of the North American Bulk-Power System, which is divided into eight Regional areas, as shown on the map and table below. The users, owners, and operators of the Bulk-Power System within these areas account for virtually all the electricity supplied in the U.S., Canada, and a portion of Baja California Norte, México.



**Note:** The highlighted area between SPP RE and SERC denotes overlapping Regional area boundaries. For example, some load serving entities participate in one Region and their associated transmission owner/operators in another.

NERC Regional Entities	
<b>FRCC</b> Florida Reliability Coordinating Council	<b>SERC</b> SERC Reliability Corporation
<b>MRO</b> Midwest Reliability Organization	<b>SPP RE</b> Southwest Power Pool Regional Entity
<b>NPCC</b> Northeast Power Coordinating Council	<b>TRE</b> Texas Reliability Entity
<b>RFC</b> ReliabilityFirst Corporation	<b>WECC</b> Western Electricity Coordinating Council

<sup>1</sup> As of June 18, 2007, the U.S. Federal Energy Regulatory Commission (FERC) granted NERC the legal authority to enforce Reliability Standards with all U.S. users, owners, and operators of the Bulk-Power System, and made compliance with those standards mandatory and enforceable. In Canada, NERC presently has memorandums of understanding in place with provincial authorities in Ontario, New Brunswick, Nova Scotia, Québec, and Saskatchewan, and with the Canadian National Energy Board. NERC standards are mandatory and enforceable in Ontario and New Brunswick as a matter of provincial law. NERC has an agreement with Manitoba Hydro making Reliability Standards mandatory for that entity, and Manitoba has recently adopted legislation setting out a framework for standards to become mandatory for users, owners, and operators in the province. In addition, NERC has been designated as the “electric reliability organization” under Alberta’s Transportation Regulation, and certain Reliability Standards have been approved in that jurisdiction; others are pending. NERC and NPCC have been recognized as standards-setting bodies by the Régie de l’énergie of Québec, and Québec has the framework in place for Reliability Standards to become mandatory. NERC’s Reliability Standards are also mandatory in Nova Scotia and British Columbia. NERC is working with the other governmental authorities in Canada to achieve equivalent recognition.

# Table of Contents

---

NERC’s Mission .....	2
Table of Contents.....	3
Executive Summary .....	5
Introduction.....	6
Issue Statement .....	6
Chapter 1 – Historical Perspective.....	7
November 9, 1965 .....	7
1965 Northeast Blackout Conclusions .....	8
July 13, 1977 New York Blackout.....	8
1977 New York Blackout Conclusions.....	8
July 2-3, 1996: West Coast Blackout.....	8
July 2-3, 1996: West Coast Blackout Conclusions .....	9
August 10, 1996.....	10
August 10, 1996 Conclusions .....	10
August 14, 2003.....	10
Perry-Ashtabula-Erie West 345 kV Transmission Line Trip.....	11
Homer City – Watercure and Homer – City Stolle Rd 345 kV Transmission Line Trips.....	13
Southeast Michigan Loss of Synchronism.....	15
2003 Northeast Blackout Conclusion.....	16
September 8, 2011 Arizona-California Outages .....	17
Other Efforts from the 2003 Blackout Affecting Relay Response to Stable Power Swings .....	17
Overall Observations from Review of Historical Events .....	17
Chapter 2 – Reliability Issues .....	18
Dependability and Security.....	18
Trade-offs Between Security and Dependability .....	18
Chapter 3 – Reliability Standard Considerations .....	20
Need for a Standard.....	20
Applicability .....	20
Identification of Circuits with Protection Systems Subject to Effects of Power Swings .....	20
Benefits of Defining Applicability for Specific Circuit Characteristics .....	21
Requirements .....	21
Conclusions.....	23
Recommendations.....	24
Appendix A – Overview of Power Swings .....	25
General Characteristics.....	25
Impedance Trajectory.....	25
Appendix B – Protection Systems Attributes Related to Power Swings .....	29
Desired Response .....	29
Response of Distance Protection Schemes.....	29
Power Swing Without Faults.....	29
Appendix C – Overview of Out-of-Step Protection Functions .....	34

---

Power Swing and Out-of-Step Phenomenon .....	34
Basic Phenomenon Using the Two-Source Model .....	34
Representation of Power Swings in the Impedance Plane .....	34
Rate of Change of the Positive-Sequence Impedance .....	35
Out-of-Step Protection Functions .....	36
Power Swing Detection Methods .....	37
Out-of-Step Tripping Function .....	42
Issues Associated With the Concentric or Dual-Blinder Methods .....	45
OOS Relaying Philosophy .....	46
References .....	47
Appendix D – Potential Methods to Demonstrate Security of Protective Relays.....	48
IEEE PSRC WG D6 Method .....	48
Calculation Methods based on the Graphical Analysis Method .....	48
Method 1 .....	49
Method 2 .....	50
Voltage Dip Screening Method .....	53
Discussion of the Results .....	56
Practical Power System Example .....	56
Appendix E – System Protection and Control Subcommittee .....	59
Appendix F – System Analysis and Modeling Subcommittee .....	60
Appendix G – Additional Contributors.....	61

---

*This technical document was approved by the NERC Planning Committee on August 19, 2013.*

# Executive Summary

---

After the August 14, 2003 Northeast Blackout, the Federal Energy Regulatory Commission (FERC) raised concerns regarding performance of transmission line protection systems during power swings. These concerns resulted in issuance of a directive in FERC Order No. 733 for NERC to develop a Reliability Standard that requires the use of protective relay systems that can differentiate between faults and stable power swings and, when necessary, phases out protective relay systems that cannot meet this requirement. In the order, FERC stated that operation of zone 3 and zone 2 relays during the August 2003 blackout contributed to the cascade, and that these relays operated because they were unable to distinguish between a dynamic, but stable power swing and an actual fault. FERC further cited the U.S.-Canada Power System Outage Task Force as identifying dynamic power swings and the resulting system instability as the reason why the cascade spread. While FERC did direct development of a Reliability Standard, FERC also noted that it is not realistic to expect the ERO to develop Reliability Standards that anticipate every conceivable critical operating condition applicable to unknown future configurations for regions with various configurations and operating characteristics. Further, FERC acknowledged that relays cannot be set reliably under extreme multi-contingency conditions covered by the Category D contingencies of the TPL Reliability Standards.

In response to the FERC directive, NERC initiated Project 2010-13.3 – Phase 3 of Relay Loadability: Stable Power Swings to address the issue of protection system performance during power swings. To support this effort, and in response to a request for research from the NERC Standards Committee, the NERC System Protection and Control Subcommittee (SPCS), with support from the System Analysis and Modeling Subcommittee (SAMS), has developed this report to promote understanding of the overall concepts related to the nature of power swings; the effects of power swings on protection system operation; techniques for detecting power swings and the limitations of those techniques; and methods for assessing the impact of power swings on protection system operation.

As part of this assessment the SPCS reviewed six of the most significant system disturbances that have occurred since 1965 and concluded that operation of transmission line protection systems during stable power swings was not causal or contributory to any of these disturbances. Although it might be reasonable, based on statements in the U.S.-Canada Power System Outage Task Force final report, to conclude this was a causal factor on August 14, 2003, subsequent analysis clarifies the line trips that occurred prior to the system becoming dynamically unstable were a result of steady-state relay loadability. The causal factors in these disturbances included weather, equipment failure, relay failure, steady-state relay loadability, vegetation management, situational awareness, and operator training. While tripping on stable swings was not a causal factor, unstable swings caused system separation during several of these disturbances. It is possible that the scope of some events may have been greater without dependable tripping on unstable swings to physically separate portions of the system that lost synchronism.

Based on its review of historical events, consideration of the trade-offs between dependability and security, and recognizing the indirect benefits of implementing the transmission relay loadability standard (PRC-023), the SPCS concludes that a NERC Reliability Standard to address relay performance during stable power swings is not needed, and could result in unintended adverse impacts to Bulk-Power System reliability.

The SPCS came to this conclusion in the course of responding to the Standards Committee request for research. During this process the SPCS evaluated several alternatives for addressing the concerns stated in Order No. 733. While the SPCS recommends that a Reliability Standard is not needed, the SPCS recognizes the directive in FERC Order No. 733 and the Standards Committee request for research to support Project 2010-13.3. Therefore, the SPCS provides recommendations for applicability and requirements that can be used if NERC chooses to develop a standard. The SPCS recommends that if a standard is developed, the most effective and efficient use of industry resources would be to limit applicability to protection systems on circuits where the potential for observing power swings has been demonstrated through system operating studies, transmission planning assessments, event analyses, and other studies, such as UFLS assessments, that have identified locations at which a system separation may occur. The SPCS also proposes, as a starting point for a standard drafting team, criteria to determine the circuits to which the standard should be applicable, as well as methods that entities could use to demonstrate that protection systems on applicable circuits are set appropriately to mitigate the potential for operation during stable power swings.

# Introduction

---

## Issue Statement

After the August 14, 2003 Northeast Blackout, the Federal Energy Regulatory Commission (FERC) raised concerns regarding performance of transmission line protection systems during power swings. These concerns resulted in issuance of a directive in FERC Order No. 733 for NERC to develop a Reliability Standard that requires the use of protective relay systems that can differentiate between faults and stable power swings and, when necessary, phases out protective relay systems that cannot meet this requirement. In the order, FERC stated that operation of zone 3 and zone 2 relays during the August 2003 blackout contributed to the cascade, and that these relays operated because they were unable to distinguish between a dynamic, but stable power swing and an actual fault. FERC further cited the U.S.-Canada Power System Outage Task Force as identifying dynamic power swings and the resulting system instability as the reason why the cascade spread. While FERC did direct development of a Reliability Standard,<sup>2</sup> FERC also noted that it is not realistic to expect the ERO to develop Reliability Standards that anticipate every conceivable critical operating condition applicable to unknown future configurations for regions with various configurations and operating characteristics. Further, FERC acknowledged that relays cannot be set reliably under extreme multi-contingency conditions covered by the Category D contingencies of the TPL Reliability Standards.

In response to the FERC directive, NERC initiated Project 2010-13.3 – Phase 3 of Relay Loadability: Stable Power Swings to address the issue of protection system performance during power swings. To support this effort, and in response to a request for research from the NERC Standards Committee, the NERC System Protection and Control Subcommittee (SPCS), with support from the System Analysis and Modeling Subcommittee (SAMS), has developed this report to promote understanding of the overall concepts related to the nature of power swings; the effects of power swings on protection system operation; techniques for detecting power swings and the limitations of those techniques; and methods for assessing the impact of power swings on protection system operation. The SPCS also proposes, as a starting point for a standard drafting team, criteria to determine the circuits to which the standard should be applicable, as well as methods that entities could use to demonstrate that protection systems on applicable circuits are appropriately set to mitigate the potential for operation during stable power swings.

The SPCS recognizes there are many documents available in the form of textbooks, reports, and transaction papers that provide detailed background on this subject. Therefore, in this report, the SPCS has intentionally limited information on subjects covered elsewhere to an overview of the issues and has provided references that can be consulted for additional detail. The subject matter unique to this report discusses the issues that must be carefully considered, to avoid unintended consequences that may have a negative impact on system reliability, when addressing the concerns stated in Order No. 733.

---

<sup>2</sup> Transmission Relay Loadability Reliability Standard, 130 FERC 61,221, Order No. 733 (2010) (“Order No. 733”) at P.152.

# Chapter 1 – Historical Perspective

---

Transient conditions occur following any system perturbation that upsets the balance of power on the interconnected transmission system, such as changes in load, switching operations, and faults. The resulting transfer of power among generating units is oscillatory and often is referred to as a power swing. The presence of a power swing does not necessarily indicate system instability, and in the vast majority of cases, the resulting power swing is a low-magnitude, well-damped oscillation, and the system moves from one steady-state operating condition to another. In such cases the power swings are of short duration and do not result in the apparent impedance swinging near the operating characteristic of protective relays. Examples of this behavior occurred on August 14, 2003, when there were ten occurrences of transmission lines tripping due to heavy line loading. Each line trip resulted in a low-magnitude, well-damped transient and the transmission system reaching a new stable operating point; however, due to the heavy line loading the apparent impedance associated with the new operating point was within a transmission line relay characteristic.<sup>3</sup> Secure operation of protective relays for these conditions is addressed by NERC Reliability Standards PRC-023 – Transmission Relay Loadability and PRC-025 – Generator Relay Loadability.<sup>4</sup>

Power swings of sufficient magnitude to challenge protection systems can occur during stressed system conditions when large amounts of power are transferred across the system, or during major system disturbances when the system is operating beyond design and operating criteria due to the occurrence of multiple contingencies in a short period of time. During these conditions the angular separation between coherent groups of generators can be significant, increasing the likelihood that a system disturbance will result in higher magnitude power swings that exhibit lower levels of damping. It is advantageous for system reliability that protective relays do not operate to remove equipment from service during stable power swings associated with a disturbance from which the system is capable of recovering. Secure operation of protective relays for these conditions is the subject of a directive in Order No. 733, and is the subject of Project 2010-13.3 – Phase 3 of Relay Loadability: Stable Power Swings.

Under extreme operating conditions a system disturbance may result in an unstable power swing of increasing magnitude or a loss of synchronism between portions of the system. It is advantageous to separate the system under such conditions, and operation of protection systems associated with system instability is beyond the scope of the standard directed in Order No. 733. However, it is important that actions to address operation during stable power swings do not have the unintended consequence of reducing the dependability of protection systems to operate during unstable power swings.

Six major system disturbances are described below, including a discussion of the relationship between power swings and protection system operation and whether operation of protective relays during stable swings was causal or contributory to the disturbance.

## November 9, 1965

The November 1965 blackout, which occurred in the Northeastern United States and Ontario, provides an example of steady-state relay loadability being causal to a major blackout.

The event began when 230 kV transmission lines from a hydro generating facility were heavily loaded due to high demand of power from a major load center just north of the hydro generating facility. Heavy power transfers prior to the disturbance resulted from the load center area being hit by cold weather, coupled with an outage of a nearby steam plant.

The transmission line protection included zone 3 backup relays, which were set to operate at a power level well below the capacity of the lines. The reason for the setting below the line capacity was to detect faults beyond the next switching point from the generating plant. From the time the relays were initially set, the settings remained unchanged while the loads on the lines steadily increased.

Under this circumstance a plant operator, who was apparently unaware of the installed relay setting limitation, attempted to increase power transfer on one of the 230 kV lines. As a result, the load impedance entered the operating characteristics

---

<sup>3</sup> Informational Filing of the North American Electric Reliability Corporations in Response to Order 733-A on Rehearing, Clarification, and Request for an Extension of Time, Docket No. RM08-13-000 (July 21, 2011) (“NERC Informational Filing”), at p. 4.

<sup>4</sup> PRC-025-1 is presently in development under Project 2010-13.2 Phase 2 of Relay Loadability: Generation.



of the zone 3 line backup relay. The relay operated and tripped the line breaker. Subsequently, the rest of the lines became overloaded. As it happened, each line breaker was tripped by the zone 3 line backup relay one-by-one over a period of approximately 2.7 seconds.

When all five lines tripped, the hydro generators accelerated rapidly due to the initial reduction of connected electrical load. The resulting drop in generation at this hydro plant and the rapid build-up of generation in the interconnected system resulted in large power swings that resulted in a loss of synchronism between two portions of the system. This incident initiated a sequence of events across the power system of the northeastern seaboard. The resulting massive outage lasted from a few minutes in some locations to more than a few days in others and encompassed 80,000 square miles, directly affecting an estimated 30 million people in the United States and Canada. This was the largest recorded blackout in history at the time.

### **1965 Northeast Blackout Conclusions**

Relays tripping due to stable power swings were not contributory or causal factors in this blackout. Relays applied to 230 kV transmission lines tripping due to load and a lack of operator knowledge of relay loadability limitations caused and contributed to this outage. The Bulk-Power System is protected against a recurrence of this type of event by the requirements in NERC Reliability Standard PRC-023-2.

### **July 13, 1977 New York Blackout**

This disturbance resulted in the loss of 6,000 MW of load and affected 9 million people in New York City. Outages lasted for up to 26 hours. A series of events triggering the separation of the Consolidated Edison system from neighboring systems and its subsequent collapse began when two 345 kV lines on a common tower in northern Westchester County were struck by lightning and tripped out. Over the next hour, despite Consolidated Edison (Con Edison) dispatcher actions, the system electrically separated from surrounding systems and collapsed. With the loss of imports, generation in New York City was not sufficient to serve the load in the city.

Major causal factors were:

- Two 345 kV lines experienced a phase B-to-ground fault caused by a lightning strike.
- A nuclear generating unit was isolated due to the line trips and tripped due to load rejection. Loss of the ring bus also resulted in the loss of another 345 kV line.
- About 18.5 minutes later, two more 345 kV lines tripped due to lightning. One automatically reclosed and one failed to reclose isolating the last Con Edison interconnection to the northwest.
- The resulting surge of power caused another line to trip due to a relay with a bent contact.
- About 23 minutes later, a 345 kV line sagged into a tree and tripped out. Within a minute a 345/138 kV transformer overloaded and tripped.
- The tap-changing mechanism on a phase-shifting transformer carrying 1150 MW failed, causing the loss of the phase-shifting transformer.

The two remaining 138 kV ties to Con Edison tripped on overload isolating the system. Insufficient generation in the isolated system caused the Con Edison island to collapse.

### **1977 New York Blackout Conclusions**

Relays tripping due to stable power swings were not contributory or causal factors in this blackout. A series of line and transformer trips due to weather, equipment failure, relay failure, and overloads caused and contributed to this outage.

### **July 2-3, 1996: West Coast Blackout**

On July 2, 1996 portions of the Western Interconnection were unknowingly operated in an insecure state. The July 2 disturbance was initiated at 14:24 MST by a line-to-ground fault on the Jim Bridger – Kinport 345 kV line due to a flashover to a tree. A protective relay on the Jim Bridger – Goshen 345 kV line misoperated due to a malfunctioning local delay timer, de-energizing the line and initiating a remedial action scheme which tripped two units at the Jim Bridger generating station. The initial line fault, subsequent relay misoperation, inadequate voltage support, and unanticipated system conditions led

to cascading outages causing interruption of service to several million customers and the formation of five system islands. Customer outages affected 11,850 MW of load in the western United States and Canada, and Baja California Norte in Mexico. Outages lasted from a few minutes to several hours.

Major causal factors were:

- A 345 kV line sagged due to high temperatures and loading causing a flashover to a tree within the right-of-way and the line was de-energized properly. A second line simultaneously tripped incorrectly due to a protective relay malfunction.
- Output of a major generating plant was reduced by design due to the two line trips. Two of four generating units at that plant were correctly tripped via a Remedial Action Scheme. The trips of these units caused frequency in the Western Interconnection to decline.
- About 2 seconds later, the Round Up – LaGrand 230 kV line tripped via a failed zone 3 relay.
- About 13 seconds later a couple of small units tripped via field excitation overcurrent.
- About 23 seconds later, the Anaconda – Amps (Mill Point) 230 kV line tripped via a zone 3 relay due to high line loads.
- Over the next 12 seconds, numerous lines tripped due to high loads, low voltage at line terminals, or via planned operation of out-of-step relaying. Low frequency conditions existed in some areas during many of these trips.
- The Western Interconnection separated into five planned islands designed to minimize customer outages and restoration times. The separation occurred mostly by line relay operation with three exceptions: Utah was separated from Idaho by the Treasureton Separation Scheme, Southern Utah separated by out-of-step relaying, and Nevada separated from SCE by out-of-step relaying.

On July 3, 1996, at 2:03 p.m. MST a similar chain to the July 2, 1996 events began. A line-to-ground fault occurred on the Jim Bridger – Kinport 345 kV line due to a flashover to a tree. A protective relay on the Jim Bridger – Goshen 345 kV line misoperated due to a malfunctioning local delay timer, de-energizing the line and initiating a remedial action scheme (RAS) which tripped two units at the Jim Bridger generating station. Scheduled power limits were reduced on the California – Oregon Intertie (COI) north-to-south pending the results of technical studies being conducted to analyze the disturbance of the previous day. The voltage in the Boise area declined to about 205 kV over a three minute period. The area system dispatcher manually shed 600 MW of load over the next two minutes to arrest further voltage decline in the Boise area, containing the disturbance and returning the system voltage to normal 230 kV levels. All customer load was restored within 60 minutes.

The Western Systems Coordinating Council Disturbance Report For the Power System Outages that Occurred on the Western Interconnection on July 2, 1996 and July 3, 1996 approved by the WSCC Operations Committee on September 19, 1996 includes numerous recommendations one of which is the following:

- The WSCC Operations Committee shall oversee a review of out-of-step tripping and out-of-step blocking within the WSCC region to evaluate adequacy. This includes:
  1. Out-of-step relays that operated;
  2. Out-of-step relays that did not operate but should have; and
  3. Out-of step conditions that caused operation of impedance relays.
- Work by C.W. Taylor<sup>5</sup> following the disturbance report recommended the review of the use of zone 3 relays which was a contributing factor to the severity of this disturbance.

### **July 2-3, 1996: West Coast Blackout Conclusions**

Relays tripping due to stable power swings was not causal or contributory to the July 2-3 West Coast Blackout. Out-of-step relaying did play a role as a safety net designed to limit the extent and duration of customer outages and restoration times.

---

<sup>5</sup> Taylor, C.W., Erickson, Dennis C., IEEE Computer Applications in Power, Vol. 10, Issue 1, 1997.

Unstudied system conditions including unexpectedly high transfer conditions coupled with a series of line trips due to vegetation intrusion, relay malfunctions, and relay loadability issues caused and contributed to this outage.

## August 10, 1996

At 15:48 PST on August 10, 1996, a major system disturbance separated the Western Interconnection into four islands, interrupting service to 7.5 million customers, with total load loss of 30,390 MW. The interruption period ranged from several minutes to nearly nine hours.

The pre-event system conditions in the Western Interconnection were characterized by high north-to-south flows from Canada to California. At 15:42:37, the Allston – Keeler 500 kV line sagged close to a tree and flashed over, additionally forcing the Pearl – Keeler 500 kV line out of service due to 500/230 kV transformer outage and breaker replacement work at Keeler. The line was tripped following unsuccessful single-pole reclosure. The 500 kV line outage caused overloading and eventual tripping of several underlying 115 kV and 230 kV lines, also in part due to reduced clearances. System voltages sagged partly because several plants were operated in var regulation mode. At 15:47:37, sequential tripping of all units at McNary began due to excitation protection malfunctions at high field voltage as units responded to reduced system voltages.

Bonneville Power Administration (BPA) automatic generation control (AGC) further aggravated the situation by increasing generation in the upper Columbia area (Grand Coulee and Chief Joseph) to restore the generation-load imbalance following McNary tripping. As a result of the above outages and shift of generation northward, sustained power oscillations developed across the interconnection. The magnitude of power and voltage oscillations further increased, as Pacific HVdc Intertie controls started participating in the oscillation. These oscillations were a major factor leading to the separation of the California – Oregon Intertie and subsequent islanding of the Western Interconnection system.

Ultimately, the magnitude of voltage and current oscillations caused opening of two COI 500 kV lines (Malin – Round Mountain #1 and #2 500 kV lines) by switch-onto-fault relay logic. The third COI 500 kV line tripped 170 ms later. Some of the power that was flowing into northern California surged east and then south through Idaho, Utah, Colorado, Arizona, New Mexico, Nevada, and southern California. Numerous transmission lines in this path subsequently tripped due to out-of-step conditions and low system voltage. Because at that time the Northeast – Southeast separation scheme was kept out of service when all COI lines were in operation, the Western Interconnection experienced uncontrolled islanding. Fifteen large thermal and nuclear plants in California and the desert southwest failed to ride through the disturbance and tripped after the system islanding, thereby delaying the system restoration.

## August 10, 1996 Conclusions

Relays tripping due to stable power swings were not causal or contributory to the August 10th West Coast Blackout. System operation was unknowingly in an insecure state prior to the outage of the Keeler-Allston 500 kV line due to reduced clearances resulting from a season of rapid tree growth and stagnant atmospheric conditions. Outage of the Keeler-Allston 500 kV line precipitated the overloading and tripping of underlying parallel 230 kV and 115 kV lines, causing undesirable tripping of key hydro units, voltage drops, and subsequent increasing of power oscillations, all of which led to tripping of the COI and other major transmission lines separating the Western Interconnection into four islands. The result was widespread uncontrolled outage of generation and the interruption of service to approximately 7.5 million customers.

## August 14, 2003

Similar to a number of the disturbances discussed above, the disturbance on August 14, 2003 concluded with line trips during power swings that were preceded by many outages due to other causes. The progression of cascading outages on August 14, 2003 was initially caused by lines contacting underlying vegetation (the basis for Blackout Recommendation 4<sup>6</sup> and FAC-003), followed by a series of lines tripping due to steady-state relay loadability issues (the basis for Blackout Recommendation 8a<sup>7</sup> and PRC-023). After the system was severely weakened by these outages, line trips occurred in response to power swings.

---

<sup>6</sup> Approved by the NERC Approved by the Board of Trustees, February 10, 2004.

<sup>7</sup> Ibid.

In the days and hours preceding the early afternoon of August 14 the power system experienced a number of generation and transmission outages that resulted in increased transfers of power between portions of the system. During the early afternoon a number of lines tripped, first due to contact with underlying vegetation and then due to load encroaching into the operating characteristics of phase distance relays. The events occurred over a period of hours, with sufficient time between events for the system to find a new steady-state condition after each event.

In Order No. 733 and Order No. 733-A FERC discussed tripping of fourteen transmission lines to support the directive pertaining to conditions in which relays misoperate due to stable power swings. FERC cited the Blackout Report<sup>8</sup>, stating the system did not become dynamically unstable until at least the Thetford – Jewell 345 kV line tripped at 16:10:38 EDT. FERC noted that up until this point, with each dynamic, but stable, power swing, the transmission system recovered and appeared to stabilize. However, as the power swings and oscillations increased in magnitude, zone 3, zone 2, and other relays on fourteen key transmission lines reacted as though there was a fault in their protective zone even though there was no fault. These relays were not able to differentiate the levels of currents and voltages that the relays measured, because of their settings, and consequently operated unnecessarily.<sup>9</sup> The Commission’s directive pertains to conditions in which relays misoperate due to stable power swings that were identified as propagating the cascade during the August 2003 Blackout.<sup>10</sup>

NERC subsequently clarified that the fourteen lines did not trip due to stable power swings; ten of these lines tripped in response to the steady-state loadability issue addressed by Reliability Standard PRC-023, while the last four lines tripped in response to dynamic instability of the power system. Although the Blackout Report states that the system did not become dynamically unstable until at least after the Thetford – Jewell 345 kV transmission line trip<sup>11</sup>, subsequent analysis indicates that the system became dynamically unstable following tripping of the Argenta – Battle Creek and Argenta – Tompkins 345 kV transmission lines, about two seconds earlier than stated in the Blackout Report. The operations not associated with faults, up to and including the initial trips of Argenta – Battle Creek and Argenta – Tompkins lines, are associated with the steady-state loadability issue addressed by Reliability Standard PRC-023.<sup>12</sup>

As the cascade accelerated, 140 discrete events occurred from 16:05:50 to 16:36. The last transmission lines to trip as result of relay loadability concerns were the Argenta –Battle Creek and Argenta – Tompkins 345 kV transmission lines in southern Michigan at 16:10:36. Upon tripping of these lines the disturbance entered into a dynamic phase characterized by significant power swings resulting in electrical separation of portions of the power system. Within the time delay associated with high-speed reclosing (500 ms) the angles between the terminals of these lines reached 80 degrees and 120 degrees respectively prior to unsuccessful high-speed reclosing of these lines.

The next line trips in the sequence of events occurred as a result of power swings. These trips occurred on the Thetford – Jewell and Hampton – Pontiac 345 kV transmission lines north of Detroit at 16:10:38. These lines tripped as the result of apparent impedance trajectories passing through the directional comparison trip relay characteristics at both terminals of each line. All subsequent line trips occurred as the result of power swings. All but two of these trips occurred during unstable power swings. A few of the events relevant to this subject are discussed below.

### **Perry-Ashtabula-Erie West 345 kV Transmission Line Trip**

The Perry – Ashtabula – Erie West 345 kV line is a three-terminal line between Perry substation in northeast Ohio and Erie West substation in northwest Pennsylvania, with a 345-138 kV autotransformer tapped at the Ashtabula substation in northeast Ohio. This transmission line trip is interesting because the line tripped at the Perry terminal by its zone 3 relay. Typically zone 3 line trips are associated with relay loadability issues, as the zone 3 time delay typically is set longer than the time it would take for a power swing to traverse the relay trip characteristic. The fact that the protection system trip was initiated by the zone 3 relay raises questions as to whether the power swing was stable or unstable. The rate-of-change of an apparent impedance trajectory typically is used as a discriminant to identify unstable swings, based on the assumption that higher rates-of-change are associated with unstable swings. In this case the speed of the apparent impedance

---

<sup>8</sup> *U.S.-Canada Power System Outage Task Force, Final Report on the August 14, 2003 Blackout in the United States and Canada: Causes and Recommendations* (Apr. 2004) (“Blackout Report”).

<sup>9</sup> *Transmission Relay Loadability Reliability Standard*, 134 FERC 61,127, Order No. 733-A (2011) (“Order No. 733-A”). Order No. 733-A at P.110.

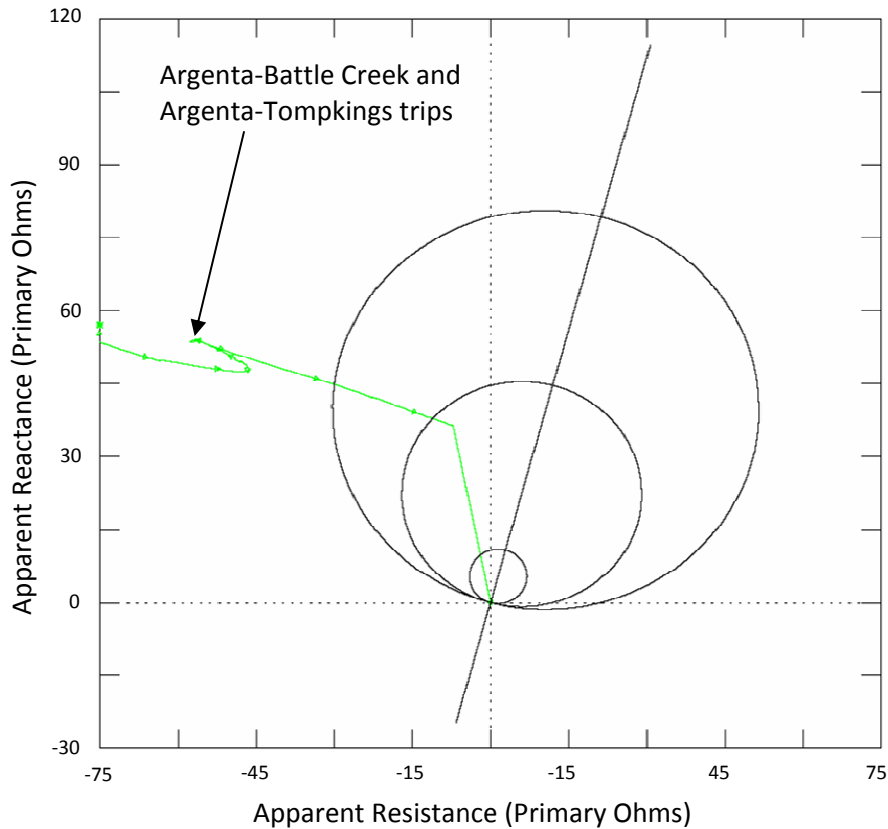
<sup>10</sup> *Id.*, P.111.

<sup>11</sup> Blackout Report at p. 82.

<sup>12</sup> NERC Informational Filing, at p. 6.

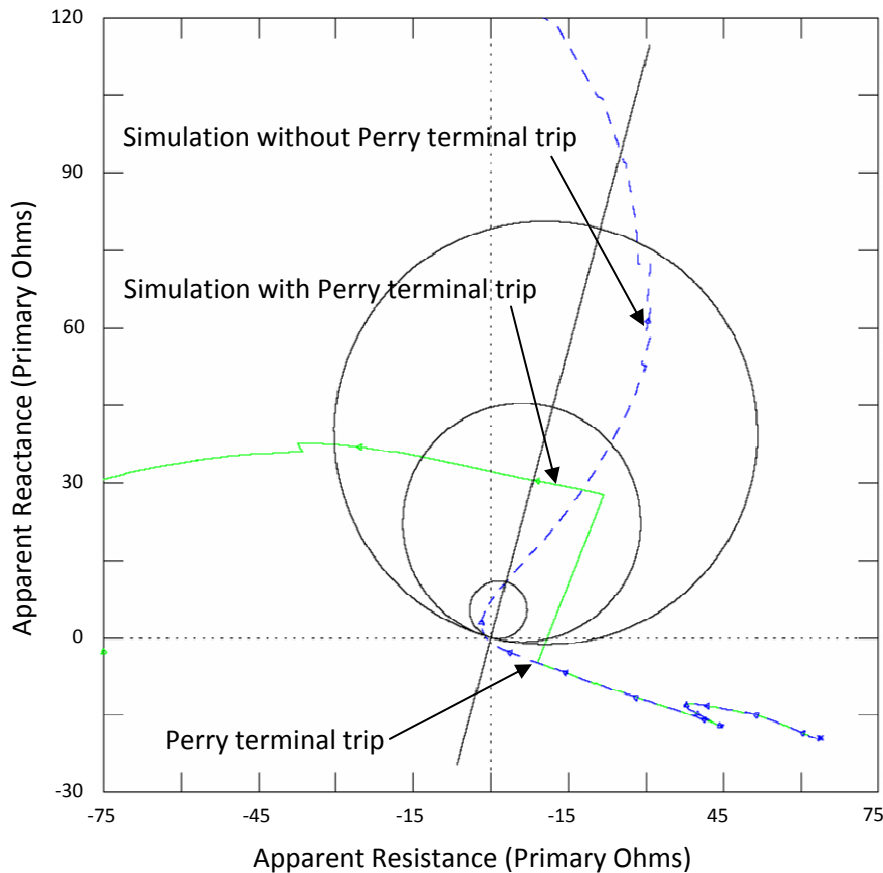
trajectory was relatively slow, as it would need to be to remain within the zone 3 characteristic long enough to initiate a trip. Dynamic simulation of the event confirmed that while this swing was slow to develop, had the line not been tripped by its zone 3 relay the swing eventually would have entered the zone 1 relay characteristic at the Erie West terminal followed by a loss of synchronism condition.

Figure 1 presents the simulated apparent impedance trajectory observed from the Perry line terminal. This figure shows that the apparent impedance swing was moving away from the relay characteristic up to the time of the Argenta – Battle Creek and Argenta – Tompkins 345 kV line trips, at which time the trajectory reversed direction and entered the zone 3 relay characteristic from the second quadrant. The apparent impedance remained in the relay characteristic long enough to initiate a zone 3 trip.



**Figure 1: Apparent Impedance Trajectory for Perry – Ashtabula 345 kV Line on August 14, 2003**

Figure 2 presents the simulated apparent impedance observed from the Erie West terminal. The first (green) apparent impedance trajectory is the simulated trajectory with the zone 3 trip at Perry simulated. With the 345 kV path from Erie West to Perry interrupted, the decreased flow on the line from Erie West into the 345-138 kV transformer at Ashtabula resulted in the apparent impedance moving to a new trajectory further from the Erie West terminal. The apparent impedance trajectory was resimulated with tripping of the Perry terminal blocked. The second (blue) trajectory demonstrates that the next swing would have been unstable, passing through the zone 1 relay characteristic and eventually crossing the system impedance indicative of a loss of synchronism condition with the system angle increasing beyond 180 degrees.



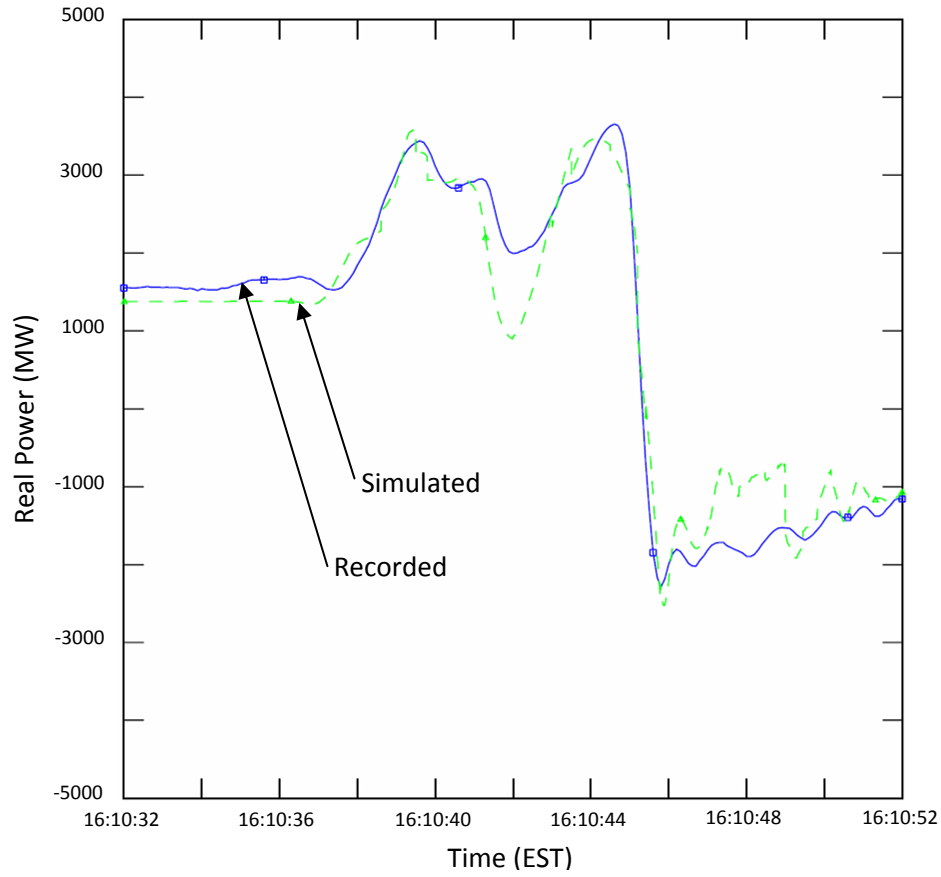
**Figure 2: Apparent Impedance Trajectory for Erie West – Ashtabula 345 kV Line on August 14, 2003**

In addition to the Perry – Ashtabula – Erie West trip demonstrating that the apparent impedance trajectory of a power swing can result in a time delayed trip, it also demonstrates that for severely stressed system conditions with a rapid succession of events exciting multiple dynamic modes, the resulting apparent impedance trajectories may vary significantly from the traditional textbook trajectories that are based on two-machine system models. This points to the difficulty of establishing standardized applications to address out-of-step conditions that are both secure and dependable for all possible system conditions.

### **Homer City – Watercure and Homer – City Stolle Rd 345 kV Transmission Line Trips**

These two transmission lines connect the Homer City generating plant in central Pennsylvania to the Watercure and Stolle Rd substations in western New York. As the power swing traveled across the system, this was the next place the swing was observable: along the interface between New York and the PJM Interconnection. These two transmission lines were tripped by their respective zone 1 relays at Homer City.

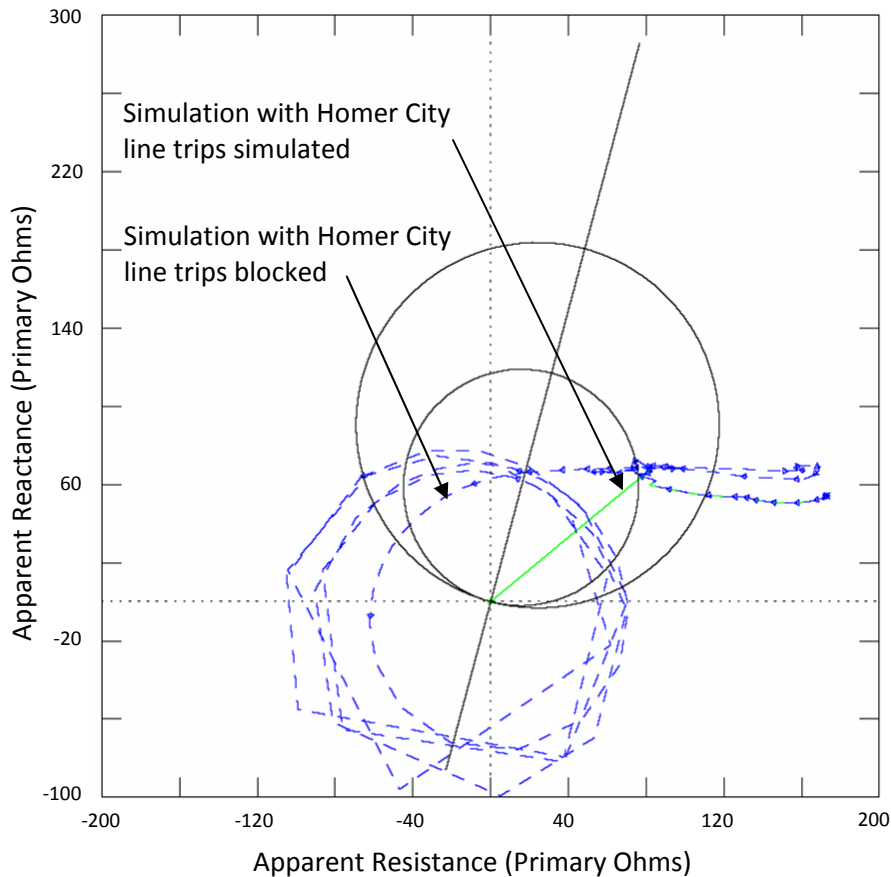
The recorded and simulated powerflow across this interface are presented in Figure 3 below. Following the separation in southern Michigan, two swings occurred between the New York and PJM systems. The first swing occurred at approximately 16:10:39.5 corresponding to tripping of the Homer City – Watercure and Homer City – Stolle Road 345 kV transmission lines. The second swing occurred approximately 4 seconds later corresponding with the New York-PJM separation completed by the Branchburg – Ramapo 500 kV line trip.



**Figure 3: PJM-New York Interface Flow on August 14, 2003**

Since only two transmission lines between the PJM Interconnection and the New York system tripped during the first swing, it raises the question as to whether these lines tripped on a stable swing, and if so, would these two portions of the system have remained synchronized if all lines comprising the PJM-New York interface had been in service at the time of the second power swing.

The dynamic simulation was run twice for this time-frame: once with the Homer City line trips modeled and once with the Homer City line trips blocked. Figure 4 presents the apparent impedance for the Homer City terminal of the Homer City – Watercure transmission line for each simulation.



**Figure 4: Apparent Impedance Trajectory for Homer City – Watercure 345 kV Line on August 14, 2003**

The first (green) apparent impedance trajectory shows the apparent impedance entering the zone 1 relay characteristic and the line tripping (represented in the plot by the apparent impedance “jumping” to the origin). The second (blue) trajectory representing the simulation with line tripping blocked demonstrates that the first swing was stable with the trajectory turning around just after entering the zone 1 relay characteristic. On the next swing, occurring about 4 seconds later, it is clear that the swing is unstable and the apparent impedance exits the relay characteristic through the second quadrant. The plot shows that with tripping of these lines blocked that these two portions of the system lose synchronism and slip poles as long as the two systems remain physically connected.

The blackout investigation team concluded that while these two lines did trip on a stable swing, these trips were not contributory to the blackout since the lines would have tripped four seconds later on the next swing, which was unstable. The blackout investigation team further concluded that since the protection systems on these lines did demonstrate the potential for tripping on stable swings, the Transmission Owners should investigate changes that could be made to improve the security of protection system operation on the Homer City 345 kV transmission lines to Watercure and Stolle Road. The Transmission Owners have performed extensive testing of the out-of-step tripping and power swing blocking functions on new protection systems using simulated power swings from the August 14, 2003 blackout investigation. This testing has identified susceptibility of some protection systems to misoperate, which highlights the difficulty of providing both dependable and secure operation for every conceivable critical operating condition, particularly when considering conditions well beyond the N-1 or N-2 conditions for which power systems typically are designed and when considering more complex swings with multiple modes and time-varying voltage..

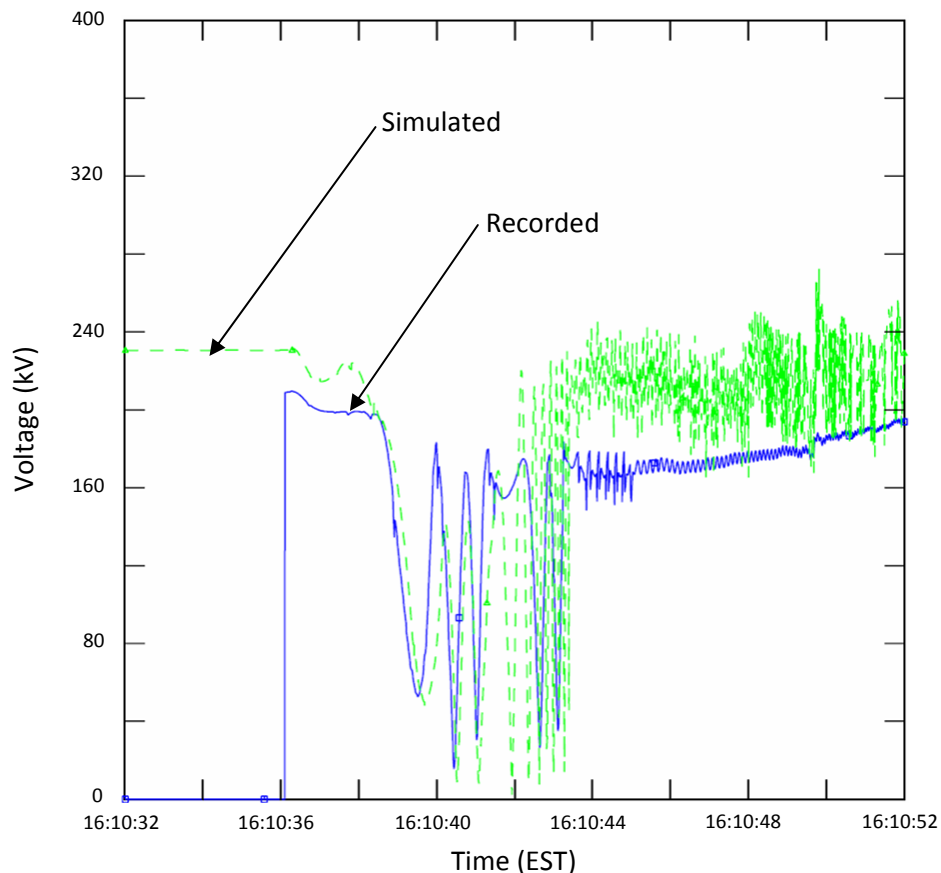
### **Southeast Michigan Loss of Synchronism**

Following the Michigan East-West separation and Perry – Ashtabula – Erie West trip, the power flow from Ontario to Michigan and from Michigan to Ohio increased. During this time voltages in southeast Michigan began to drop rapidly. In



response to the decreased voltage and corresponding drop in load, the generating units south of Detroit began to accelerate rapidly and slipped two poles.

The system conditions associated with the generating units slipping two poles resulted in turbine trips on many of these generating units. As mechanical power to the turbines was reduced, the generators slowed down and frequency in southern Detroit began to decline. Many of these generating units rely on a reverse power relay to trip the generator after the turbine is tripped and mechanical power is reduced. Since these units lost synchronism with the rest of the system the electrical power on these units changed direction with each pole slip and the reverse power condition was not sustained long enough for the reverse power relay to trip the unit. As a result, the southeast Michigan portion of the system operated asynchronously while connected through the two 120 kV lines. Figure 5 illustrates the effect of the out-of-step conditions on system voltage. The first trace (blue) is the recorded voltage at the Keith substation in southern Ontario which shows five voltage swings of approximately 0.8 per unit corresponding to each pole slip until the mechanical input to the turbines was tripped. This plot illustrates the voltage stress on equipment when two systems operate asynchronously without dependable tripping for out-of-step conditions. Generating units may experience corresponding shaft stress during each pole slip.



**Figure 5: Keith Voltage During Southern Michigan Loss-of-Synchronism**

### 2003 Northeast Blackout Conclusion

Relays tripping due to stable power swings were not contributory or causal factors in this blackout. Although it is reasonable to conclude this was a causal factor based on statements in the Blackout Report and cited in FERC Order No. 733 and subsequent FERC orders, subsequent analysis cited in the NERC Informational filing clarifies that only two 345 kV lines tripped in response to stable power swings, and these two trips occurred well into the cascading portion of the disturbance. Simulations confirm that if the relays had not tripped these lines on the stable power swing, the relays would have tripped on an unstable swing a few seconds later, with no significant difference in the subsequent events or the magnitude and duration of the resulting outages. Recorded and simulated data also demonstrate the adverse effect of not having dependable tripping for unstable power swings.

## **September 8, 2011 Arizona-California Outages**

This disturbance is well documented in the April 2012 FERC/NERC Staff Report on the September 8, 2011 Blackout, available on the NERC website. Twenty seven findings and recommendations were made in this report. Relays tripping due to stable power swings were not cited in any of the recommendations from the NERC/FERC report. Relays tripping due to stable power swings were not contributory or causal factors in this blackout.

## **Other Efforts from the 2003 Blackout Affecting Relay Response to Stable Power Swings**

The August 14, 2003 northeast blackout spawned the effort that raised the bar on relay loadability. Efforts included the “Zone 3” and “Beyond Zone 3” relays reviews that preceded development of the PRC-023 Transmission Relay Loadability standard. The SPCTF report, *Protection System Review Program – Beyond Zone 3*, dated December 7, 2006 identified that 22 percent of the 11,499 EHV relays reviewed required changes to meet the NERC Recommendation 8a criterion or a Technical Exception (equivalent to the criteria under Requirement R1 of PRC-023-2). Methods used to attain the greater loadability typically included limiting relay reaches or changing relay characteristic shapes or both. These relay changes affected relays with the largest distance zones susceptible to tripping on stable power swings such as the Perry – Ashtabula – Erie West zone 3 trip discussed above. In many cases these relay changes also affected distance zones that trip high-speed such as zone 2 functions that are part of communication-assisted protection systems, and in some cases even zone 1 relays that trip without intentional time delay. While it is not possible to quantify the extent to which these modifications improved security against tripping for stable power swings, reducing the resistive reach of phase distance protection functions does increase the power system angular separation necessary to enter the relay characteristic. Thus, these changes increased security throughout North America for relays susceptible to tripping on stable power swings.

## **Overall Observations from Review of Historical Events**

Relays tripping on stable power swings were not causal or contributory in any of the historical events reviewed. Causal factors in the events included lines sagging into trees, lines tripping via relay action due to high loads, lines tripping due to relay malfunctions, and other causes. These causes have been addressed in several NERC Reliability Standards.

Relays tripping on unstable swings occurred in several of the historical events reviewed. The tripping was not causal or contributory as tripping on unstable swings occurs after the system has reached the point of instability, cascading, or uncontrolled separation. However, it is possible that the scope of some events may have been greater without dependable tripping on unstable swings to physically separate portions of the system that lost synchronism.

## Chapter 2 – Reliability Issues

---

### Dependability and Security

When considering power swings, both facets of protection system reliability are important to consider. To support power system reliability it is desirable that protection systems are secure to prevent undesired operation during stable power swings. It also is desirable to provide dependable means to separate the system in the event of an unstable power swing.

Protection system security during stable swings is important to maintaining reliable power system operation. Unnecessary tripping of transmission lines during stable power swings may lead to cascade tripping due to increased loading on parallel circuits or may lead directly to power system instability by increasing the apparent impedance between two portions of the system.

Ensuring that dependable means are available to separate portions of the system that have lost synchronism is essential to maintaining reliable power system operation. Failing to physically separate portions of the system that have lost synchronism will result in adverse impacts due to the system slipping poles, resulting in significant voltage and power flow deviations occurring at the system slip frequency. Near the electrical center of the power swing the voltage deviations will have amplitude of nearly 1 per unit, stressing equipment insulation. Rapid changes in power flow also stress equipment, in particular rotating machines that are participating in the swings.

### Trade-offs Between Security and Dependability

Secure and dependable operation of protection systems are both important to power system reliability. While methods for discriminating between stable and unstable power swings have improved over time, ensuring both secure and dependable operation for all possible system events remains a challenge. Testing out-of-step functions using simulated power system swings from the August 14, 2003 blackout investigation has identified susceptibility of some protection systems to misoperate, which highlights the difficulty of providing both dependable and secure operation for every conceivable critical operating condition, particularly when considering conditions well beyond the N-1 or N-2 conditions for which power systems typically are designed and when considering more complex swings with multiple modes and time-varying voltage.

While the directive in Order No. 733 is focused on protective relays operating unnecessarily due to stable power swings, it is important that focusing on this aspect of security does not occur to the detriment of system reliability by producing the unintended consequence of decreasing ability to dependably identify unstable swings and separate portions of the system that have lost synchronism.

It certainly is possible to provide transmission line protection that can discriminate between fault and power swing conditions. Current-based protection systems such as current differential or phase comparison can be utilized to provide a high degree of security against operation for stable power swings. However, application of such protection systems in locations where the system may be prone to unstable power swings does not provide a dependable means of separating portions of the system that lose synchronism. In such cases it would be necessary to install out-of-step protection to initiate system separation, which reintroduces the need to discriminate between stable and unstable power swings. Installing current-based protection systems does not remove the need to install impedance-based back up protection, which reintroduces the need to discriminate between stable and unstable power swings.

Recognizing that no one protection system design can provide security and dependability for all possible power swings under all possible system conditions, two questions must be considered: (1) for what conditions must protection systems operate reliably, and (2) under conditions for which reliable operation cannot be assured, should protection system design err on the side of security or dependability. The trade-offs between secure and dependable operation in response to system faults are discussed much more frequently than the trade-offs in response to power swings; however, there are similarities when comparing fault and power swing conditions. In both cases, a lack of dependability is more likely to result in an undesirable outcome. For a fault condition, a failure to trip will result in increased equipment damage and acceleration of rotating machines that may result in system instability. For an unstable power swing, a failure to trip will result in portions of the system slipping poles against each other and resultant increased equipment stress and an increased probability of system collapse.

By comparison, tripping an additional circuit in response to a fault may lead to unacceptable system performance; however, the potential for equipment damage or instability is less than for a failure to trip, particularly in highly networked systems. In theory tripping a circuit for a stable power swing may lead to cascade tripping of power system circuits; however, analysis of historical events supports that the probability of undesirable system performance is less than for a failure to trip for an unstable swing.

Given the relative risks associated with a lack of dependable operation for unstable power swings and the lack of secure operation for stable swings, over-emphasizing secure operation for stable powers swings could be detrimental to Bulk-Power System reliability. It therefore is preferable to emphasize dependability over security when it is not possible to ensure both for all possible system conditions.

## Chapter 3 – Reliability Standard Considerations

---

### Need for a Standard

Based on its review of historical events, consideration of the trade-offs between dependability and security, and recognizing the indirect benefits of implementing the transmission relay loadability standard (PRC-023), the SPCS concludes that a NERC Reliability Standard to address relay performance during stable swings is not needed, and could result in unintended adverse impacts to Bulk-Power System reliability.

In the course of coming to this conclusion, however, the SPCS has developed recommendations for implementing a standard. Given the directive in FERC Order No. 733 and the Standards Committee request for research to support Project 2010-13.3, the SPCS recommends that if a standard is developed it should include the following applicability and requirements.

### Applicability

Two options exist for developing requirements for secure operation of protection systems during power swings: (i) develop requirements applicable to protection systems on all circuits, or (ii) identify the circuits on which a power swing may affect protection system operation and develop requirements applicable to protection systems on those specific circuits. The effort to assess every protection system to assure it will not operate during stable power swings would be significant. An equally effective and more efficient approach would be to identify the types of circuits on which protection systems would be challenged by power swings, and limit the applicability of a new standard to these circuits.

During development of this report the SPCS explored the possibility of recommending a standard applicable to all circuits and requiring that entities verify for each circuit that either a power swing will not pass through the circuit or that the protection system on the circuit would not operate for a stable power swing. The SPCS investigated several different approaches including the analytical assessment and system study approaches described in Appendix D. Analysis of the various approaches indicated that applying one or more of these approaches to each circuit would be a significant effort with varying results that are dependent on the system topology and the assumptions specified for the analysis. Extreme system topologies are often present during actual relay trips during power swings. These topologies would be very difficult to anticipate in a study. The historical evidence supports taking a more efficient approach to limit burden on responsible entities given the limited role that undesired tripping in response to stable power swings has played in major disturbances. Such an approach is consistent with taking a risk-based approach to Reliability Standards by focusing the applicability to circuits on which protection systems are most likely to be affected during power swings.

This section recommends an approach for identifying those power system circuits on which protection systems are susceptible to operation for stable power swings. Although past system disturbances do not provide specific input on which circuits are most at risk, past disturbances demonstrate it is not necessary for a Reliability Standard to apply to all lines. In the absence of direct input from past disturbances, the SPCS believes it is reasonable to recommend an approach that uses information from existing planning and operating studies and experience, and physical attributes of power systems. This approach provides the opportunity to effectively identify circuits of concern without requiring extensive, and in many cases duplicative, studies. The recommended approach is an effective and efficient manner that can be used to limit the number of circuits for which entities are required to evaluate and provide a basis for protection system response during power swings.

### Identification of Circuits with Protection Systems Subject to Effects of Power Swings

Power system swings, stable or unstable, are caused by the relative motion of generators with respect to each other. These power swings manifest themselves as swings in the apparent impedance “seen” by protective relays due to the variations in voltages and currents which occur during these swings. Power swings are classified as local mode or inter-area mode. Local mode oscillations are characterized by units at a generating station swinging with respect to the rest of the system. This is in contrast to inter-area mode oscillations, where a coherent group<sup>13</sup> of generating stations in one part of the system is swinging against another coherent group of generators in a different part of the system.

---

<sup>13</sup> In this context, the generators in a coherent group exhibit similar waveforms for their rotor-angle response to a system disturbance.

The electrical center of a local mode swing tends to remain relatively close to the generating station that is causing the swing. The electrical center of an inter-area mode oscillation will occur between the two coherent groups of generators. Therefore, it can be concluded that stable power swings are most likely to challenge protective relays on lines terminating at generating stations or on lines between coherent groups of generators. This is a useful filter in identifying transmission lines on which protective relays should be subject to the Reliability Standard.

The electrical center of a power swing is determined by physical characteristics of the system. The electrical center may vary depending on the dispatch of generators and status of transmission equipment making it difficult to assure that all possible power swings are identified. This is particularly true when considering power swings that may occur during major system disturbances after a number of circuits have tripped. However, it is possible to identify the most likely locations of electrical centers of power swings and focus attention on protections systems applied on the circuits where the electrical centers exist. In the case of local mode oscillations the electrical center is most likely to occur in the generator step-up (GSU) transformer or on a transmission line connected to the bus on the high-side of the GSU transformer. In the case of an inter-area oscillation the electrical center is more difficult to predict; however, the electrical center already will have been identified if any planning or operating studies have identified the need to apply a System Operating Limit (SOL) based on stability constraints, or if other studies or event analyses have identified the potential for tripping during a system disturbance that includes power swings.

The standard drafting team should consider the following criteria in establishing the applicability of the Reliability Standard to limit applicability to only those transmission lines on which protective relays are most likely to be challenged during stable power swings.

- Lines terminating at a generating plant, where a generating plant stability constraint is addressed by an operating limit or Special Protection System (SPS) (including line-out conditions).
- Lines that are associated with a System Operating Limit (SOL) that has been established based on stability constraints identified in system planning or operating studies (including line-out conditions).
- Lines that have tripped due to power swings during system disturbances.
- Lines that form a boundary of the Bulk Electric System that may form an island.<sup>14</sup>
- Lines identified through other studies, including but not limited to, event analyses and transmission planning or operational planning assessments.

### **Benefits of Defining Applicability for Specific Circuit Characteristics**

Limiting the applicability of a Reliability Standard provides a number of benefits.

- Efforts may be more focused, creating the possibility to include dynamic simulations assessing a greater number of fault types and system configurations.
- It may be possible, subject to relay model availability, to model specific relay settings in the dynamic simulation software, to more precisely identify the likelihood of a stable swing entering the relay characteristic. Including relay models in transient stability simulations could be used to monitor security of settings and identify potential concerns. Present software and computing developments are reducing limitations that historically have prevented such modeling, as well as practical limits to managing the volume of data. However, models are not presently available for all tripping relay characteristics, such as when load encroachment features are used to limit the trip characteristic to meet relay loadability requirements.

### **Requirements**

The following requirements should be applicable to the circuits identified in the preceding section to mitigate the risk of protection systems operating during stable power swings.

- A requirement for each Reliability Coordinator and Planning Coordinator to identify lines that meet the criteria in the applicability section and notify the owners of applicable circuits.

---

<sup>14</sup> See NERC Reliability Standard PRC-006-1 – Automatic Underfrequency Load Shedding, Requirement R1.

A Functional Model entity with a wide-area view should have responsibility for identifying the circuits to which the standard is applicable. This approach promotes consistent application of the criteria and assures that facility owners are aware of their responsibilities, given that a facility owner may not be aware of all relevant system studies. It is most appropriate to assign this responsibility to the Reliability Coordinator and the Planning Coordinator given their wide-area view and awareness of reliability issues. Both entities should be involved since stability issues may be identified in both operating and planning studies. The standard should require periodic review to assure the list of applicable circuits is up-to-date.

- A requirement for each facility owner to document its basis for applying protection to each of its applicable circuits (as identified above), and provide this information to its Reliability Coordinator, Planning Coordinator, and Transmission Planner.<sup>15</sup>

There are multiple ways for a facility owner to mitigate the potential of protection systems tripping for stable power swings. In some cases conventional impedance-based protection may be acceptable (e.g., on a short line a mho characteristic may not be susceptible to tripping for stable swings), in other cases a modified protection characteristic may be suitable, in some cases it may be appropriate to supervise the protection to enable or to block tripping during power swings, and in some cases the consequences of failing to trip for an unstable swing may be so significant that a risk of tripping for some stable swings is deemed in the best interest of Bulk-Power System reliability. Decisions whether to apply out-of-step protection should be made between the facility owner who has knowledge of the protection system design and the Reliability Coordinator, Planning Coordinator, and Transmission Planner who have knowledge of the characteristics of the power system performance. The documented basis should include rationale for whether out-of-step protection is needed, and if so, whether out-of-step tripping or power swing blocking is applied. Although this requirement is focused on documentation, this information is necessary for Reliable Operation of the Bulk-Power System. Entities responsible for operating and planning the Bulk-Power System need this information to understand how protection systems may respond during extreme system conditions.

Entities may find the information presented in the appendices of this report useful in developing a basis for applying protection to each applicable line.

The SPCS discussed additional requirements related to modeling the tripping functions of phase protection systems responsive to power swings. Modeling these protective functions in transient stability simulations could be an effective method of verifying that protection systems will not operate on stable power swings. Default phase distance relay models exist in simulation software that can be used to monitor apparent impedance and identify lines and conditions where relay operation is possible, as well as explicit models for many typical trip function characteristics. However, existing models do not address some of the unique features, such as load encroachment, that many entities have utilized to meet the transmission relay loadability requirements. The SPCS supports use of existing relay models in operating studies and transmission planning assessments; however, the SPCS believes is not possible to implement a measurable requirement until explicit models are available. NERC, through its technical committees, could monitor the availability of relay models and provide further recommendations at an appropriate time.

Modeling the tripping functions of phase protection systems responsive to power swings would enable the Reliability Coordinator, Planning Coordinator, and Transmission Planner to identify cases for which the protection systems applied are susceptible to tripping on stable power swings. Simulation results could provide important feedback since it is not practical to consider every potential power swing at the time settings are applied to a protection system. Given the difficulty of identifying all potential power swings, it is important that any information obtained through actual events and system studies is evaluated by the facility owner. In some cases this new information may identify the need to modify a protection system design or its settings. Decisions to modify a protection system, or not, should be made between the facility owner who has knowledge of the protection system design and the Reliability Coordinator, Planning Coordinator, and Transmission Planner who have knowledge of the characteristics of both the power system performance and protection system design. Decisions whether to modify a protection system should consider the need for dependable tripping during unstable power swings in addition to the objective of secure operation for stable power swings.

---

<sup>15</sup> This and subsequent requirements should include all entities responsible for assessing dynamic performance of the Bulk-Power System. The Reliability Coordinator has responsibility for operating studies and the Planning Coordinator and Transmission Planner have responsibility for transmission planning assessments.

## Conclusions

---

Operation of transmission line protection systems was not causal or contributory to six of the most significant system disturbances that have occurred since 1965. System separation during several of these disturbances did occur due to unstable power swings, and it is likely that the scope of some events and potential for equipment damage would have been greater without dependable tripping on unstable swings to physically separate portions of the system that lost synchronism.

Given the relative risks associated with a lack of dependable operation for unstable power swings and the lack of secure operation for stable swings, it is generally preferable to emphasize dependability over security when it is not possible to ensure both for all possible system conditions. Prohibiting use of certain types of relays may have unintended negative outcomes for Bulk-Power System reliability.

Efforts to improve transmission relay loadability subsequent to the August 14, 2003 northeast blackout had a secondary effect of reducing the susceptibility of some protection systems to tripping on stable power swings. While it is not possible to quantify the extent to which these modifications improved security against tripping for stable power swings, reducing the resistive reach of phase distance protection functions does increase the power system angular separation necessary to enter the relay characteristic.

Although current-only-based protection is immune to operating during power swings, exclusive use of current-only-based protection is not practical and would reduce dependability of tripping for system faults and unstable power swings. A power system with no remote backup protection is susceptible to uncleared faults and the inability to separate during unstable power swings during extreme system events. Although current-only-based protection is secure for stable power swings and can be used on lines which require tripping on out-of-step conditions, additional separate out-of-step protection is required. Application of impedance-based backup protection and, where necessary, out-of-step protection, reintroduces the need to discriminate between stable and unstable power swings.

Although many new algorithms exist to discriminate between stable and unstable swings, testing out-of-step functions using actual power system swings has identified susceptibility of some protection systems to misoperate, which highlights the difficulty of providing both dependable and secure operation.



## Recommendations

---

Based on its review of historical events, consideration of the trade-offs between dependability and security, and recognizing the indirect benefits of implementing the transmission relay loadability standard (PRC-023), the SPCS concludes that a NERC Reliability Standard to address relay performance during stable swings is not needed, and could result in unintended adverse impacts to Bulk-Power System reliability.

While the SPCS recommends that a Reliability Standard is not needed, the SPCS recognizes the directive in FERC Order No. 733 and the Standards Committee request for research to support Project 2010-13.3. Therefore, the SPCS provides recommendations for applicability and requirements that can be used if NERC chooses to develop a standard.

# Appendix A – Overview of Power Swings

## General Characteristics

An electric power grid, consisting of generators connected to loads via transmission lines, is constantly in a dynamic state as generators automatically adjust their output to satisfy real and reactive power demand. During steady-state operating conditions, a balance exists between the power generated and the power consumed, with the absolute differences in the voltages between buses typically maintained within 5 percent and frequency within 0.02 Hz of nominal. In the balanced system state, each generator in the system maintains its voltage and internal machine rotor angle at an appropriate relationship with the other generators as dictated by required power flow conditions in the system.

Sudden changes in electrical power caused by power system faults, line switching, generator disconnection, or the loss or connection of large blocks of load, disturb the balance between the mechanical power into and the required electrical power out of generators, causing acceleration or deceleration of the generating units because the mechanical power input responds more slowly than the generator electrical power. Such system disturbances cause the machine rotor angles of the generators to swing or oscillate with respect to one another in the search for a new equilibrium state. During this period, transmission lines will experience power swings, which can be stable or unstable, depending of the severity of the disturbance. In a stable swing, the power system will return to a new equilibrium state where the generator machine rotor angle differences are within stable operating range to generate power that is balanced with the load. In an unstable swing, the generation and load do not find a balance and the machine rotor angles between coherent groups of generators continue to increase, eventually leading to loss of synchronism between the coherent groups of generators. The location at which loss of synchronism occurs is based on the physical attributes of the system and is unlikely to correspond to boundaries between neighboring utilities. When synchronism is lost among areas of a power system, the areas should be separated quickly to avoid equipment damage and to avoid possible collapse of the entire power system. Ideally, the system is separated at predetermined locations into self-contained areas, each of which can maintain a generation/load balance, where the attainment of the balance may require appropriate generation or load shedding.

## Impedance Trajectory

The dynamic state of the power system can be represented by the impedance “seen” at a bus in the power system. The two machine equivalent shown in Figure 6 can be used to illustrate the concept, where the source voltages at the two ends of the system,  $E_G$  and  $E_H$ , are constant magnitudes behind their transient impedances,  $Z_G$  and  $Z_H$ .

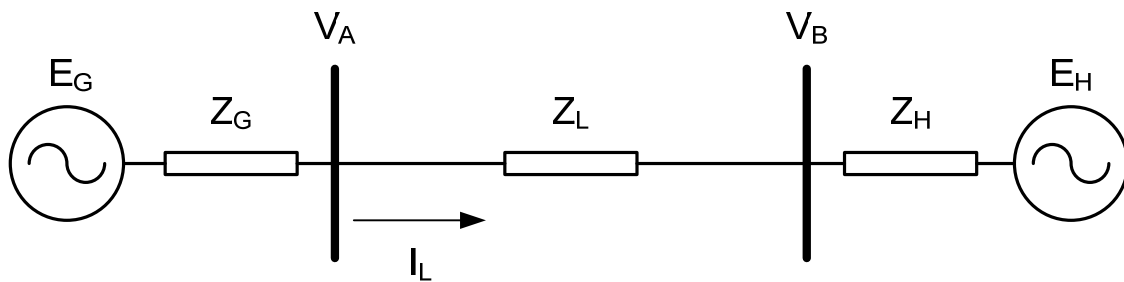
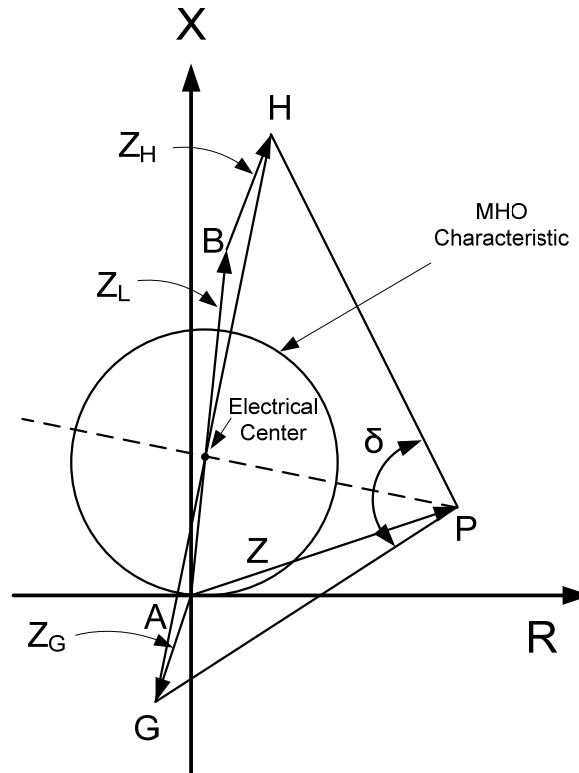


Figure 6: Two-Machine Equivalent of a Power System

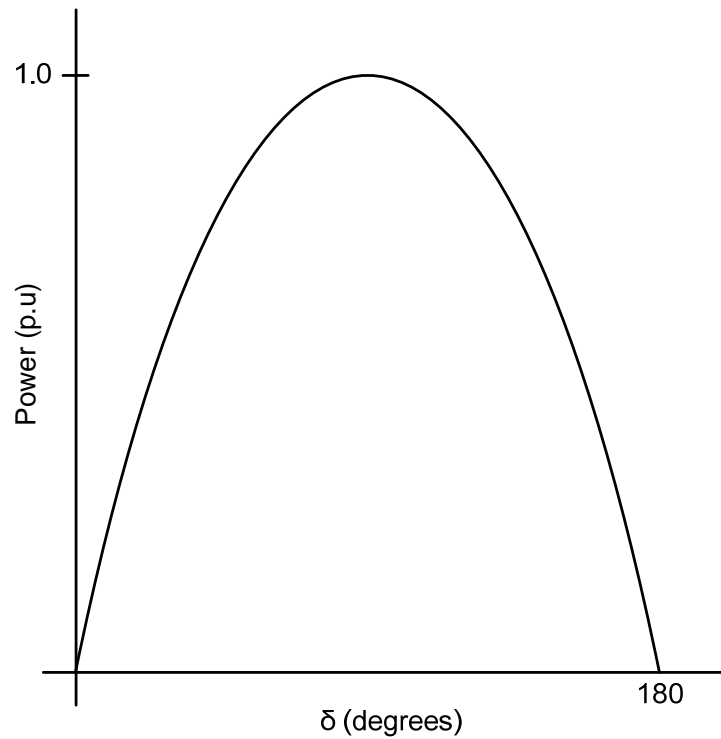
Figure 7, the geometrical interpretation of the power equation for this simple two source system, shows the R-X diagram with a mho characteristic of the relay at Bus A, set to a typical zone 1 setting for protection of the line (line impedance is  $Z_L$ ). The total impedance across the system is represented by Points G to H, where  $Z_G$  extends from the origin to point G in the third quadrant and  $Z_H$  extends from the tip of  $Z_L$  to Point H in the first quadrant.



**Figure 7: Illustration of Electrical Center of the Equivalent Power System**

With  $E_G$  and  $E_H$  of equal magnitude and with a phase angle difference of  $\delta$  ( $E_G$  leading) the apparent impedance during a swing will fall on a straight line perpendicular to and bisecting the total system impedance between G and H. As source  $E_G$  moves ahead of source  $E_H$  in angle during a swing (with magnitudes of  $E_G$  and  $E_H$  equal), the angle  $\delta$  increases. On the R-X diagram, the angle formed by the intersection of lines PG and PH at P is the angle of separation between the source voltages  $E_G$  and  $E_H$ . Point P on the R-X diagram of Figure 7 is the apparent impedance seen at Bus A. When  $\delta = 90^\circ$ , the impedance lies on the circle whose diameter is the total impedance (GH) across the system. This is the point of maximum load transfer between G and H. When  $\delta$  reaches  $120^\circ$ , and beyond, the systems are not likely to recover.<sup>16</sup> When the locus intersects the total system impedance line GH,  $\delta$  is  $180^\circ$  and the systems are completely out of phase. This point is called the electrical center (at the mid-point of the total system impedance when  $E_G$  and  $E_H$  are of equal magnitude). The voltage is zero at this point and, therefore, it is equivalent to a three-phase fault at the electrical center. As the impedance locus moves to the left of impedance line GH,  $\delta$  increases beyond  $180^\circ$  and eventually the systems will be in phase again. If the systems are not separated, source  $E_G$  continues to move ahead of source  $E_H$ , and the cycle repeats itself. When the impedance locus reaches the starting point of the swing, one slip cycle has been completed.

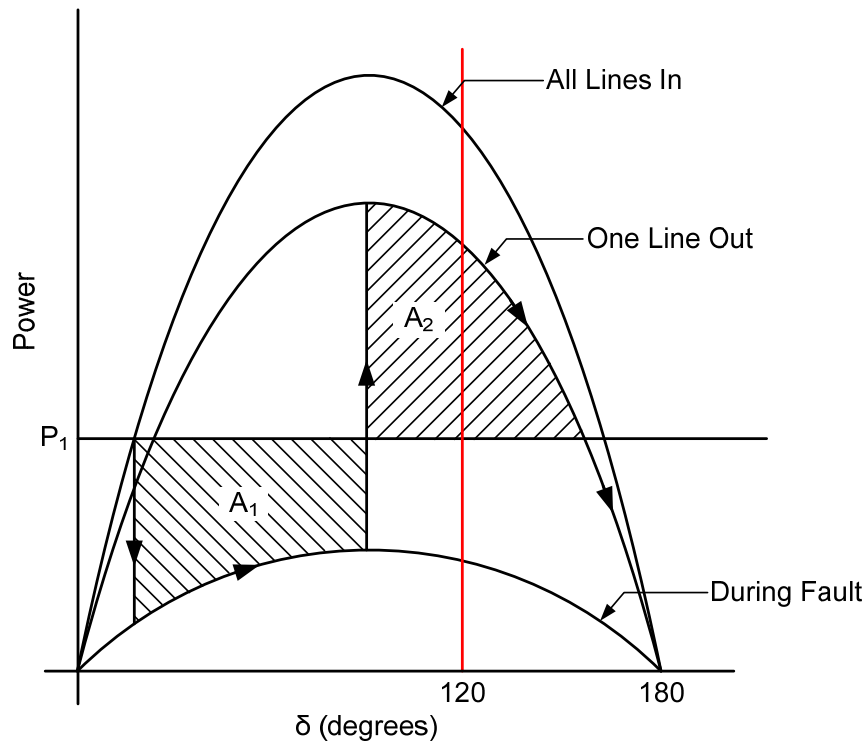
<sup>16</sup> [Application of Out-of-Step Blocking and Tripping Relays, John Berdy.](#)



**Figure 8: Power Angle Curve**

Figure 8 plots the power angle equation and shows the theoretical power transfer across a simplified transmission system such as that shown in Figure 6 for various values of  $\delta$  where  $\delta$  is the angular difference between the voltages at the two ends of the system. Normally, systems and transmission lines operate at low  $\delta$  angles that are perhaps 30 degrees or less (longer lines and weaker systems may operate at higher angles and shorter lines and stronger systems operate at lower angles).

Transmission of power in actual power systems is more complex than in the simple two source model discussed above. Two systems of coherent generators are typically connected by several lines of varying voltages. The plot of the power angle equation will vary with system conditions. An example is illustrated in Figure 9. This example illustrates conditions that may exist during a severe destabilizing fault and its aftermath. Prior to the fault, the system is stable, transmitting an amount of power  $P_1$  from one system to the other. When the severe fault occurs, the transfer capability of the system is reduced. The power delivered by the generators is less than the input from their prime movers, which causes the sending generators to accelerate, increasing the angle between the systems. When the faulted line is cleared, the transfer capability is increased, but to a lower level than the pre-fault level, due to the loss of the faulted line. The power delivered by the accelerated generators at this angle is greater than the input from their prime movers, which causes the generators to decelerate. For this condition, the system angle will continue to increase as the generators decelerate. If the angle is greater than 90 degrees, then the angle increases as the power delivered is lowered and the deceleration rate is reduced. If the angle reaches 120 degrees and is still increasing, it is likely that the system will not reach equilibrium (the decelerating area  $A_2$  equals the accelerating area  $A_1$ ) before the power delivered by the generators decreases below the prime mover inputs. If that occurs, the generators will accelerate again and pull out of synchronism.



**Figure 9: Power Angle Curve for Various Conditions**

At any given relay location, it is impossible to predict all possible system configurations and power transfer capabilities. The critical angle for maintaining stability will vary depending on the contingency and the system condition at the time the contingency occurs; however, the likelihood of recovering from a swing that exceeds 120 degrees is marginal and 120 degrees is generally accepted as an appropriate basis for setting out-of-step protection.<sup>17</sup> Given the importance of separating unstable systems, defining 120 degrees as the critical angle is appropriate to achieve a proper balance between dependable tripping for unstable power swings and secure operation for stable power swings.

<sup>17</sup> Ibid.

# Appendix B – Protection Systems Attributes Related to Power Swings

---

## Desired Response

A transmission line protection system is required to detect line faults and trip appropriately. This applies during swing conditions where, in addition, the following also applies:

- (a) If the power swing is stable, from which the system will recover, a line protection should not operate because the unnecessary loss of lines could exacerbate the power swing to the extent that a stable swing becomes unstable. Hence, in this case, the relevant protections should be set to not operate on detection of a power swing. This may be achievable by selection of the protection system operating characteristics and settings, or may require dedicated logic to block operation.
- (b) If the power swing is unstable, also referred to as an out-of-step condition, separation at predetermined locations is desirable, as previously mentioned. To this end, line protection systems that should not trip on the out-of step condition should be blocked, while protection systems on lines that have been identified as the desired separation points should have out-of-step tripping capability.

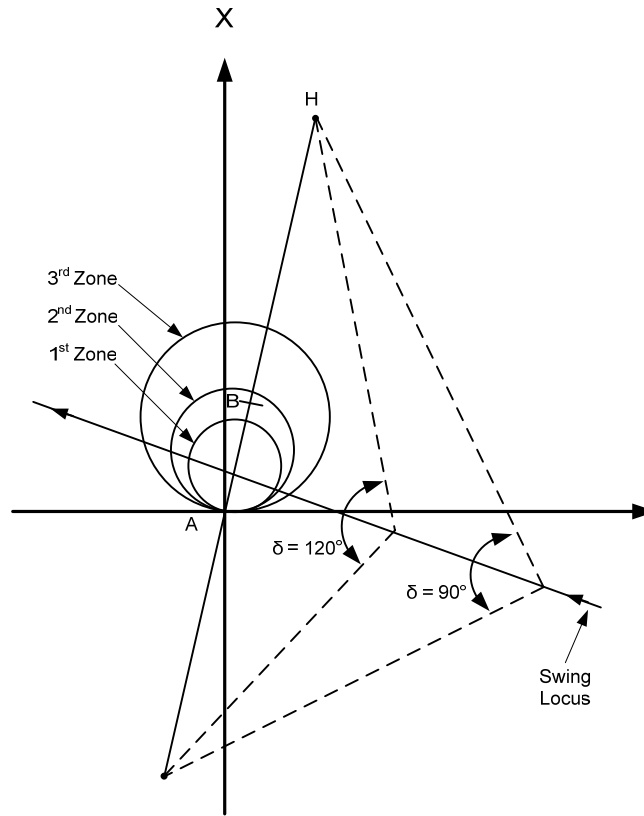
The blocking requirements set out in (a) and (b) above create a condition where if an internal fault occurs during the power swing, the line protection is unable to perform its protection function, unless the blocking is removed. The challenge is the manner in which the blocking can be reliably removed. Methods that have been used to address this condition are discussed in the IEEE Power System Relaying Committee Working Group WG D6 report, *Power Swing and Out-of-Step Considerations on Transmission Lines*, July 2005..

## Response of Distance Protection Schemes

### Power Swing Without Faults

#### *Distance Elements*

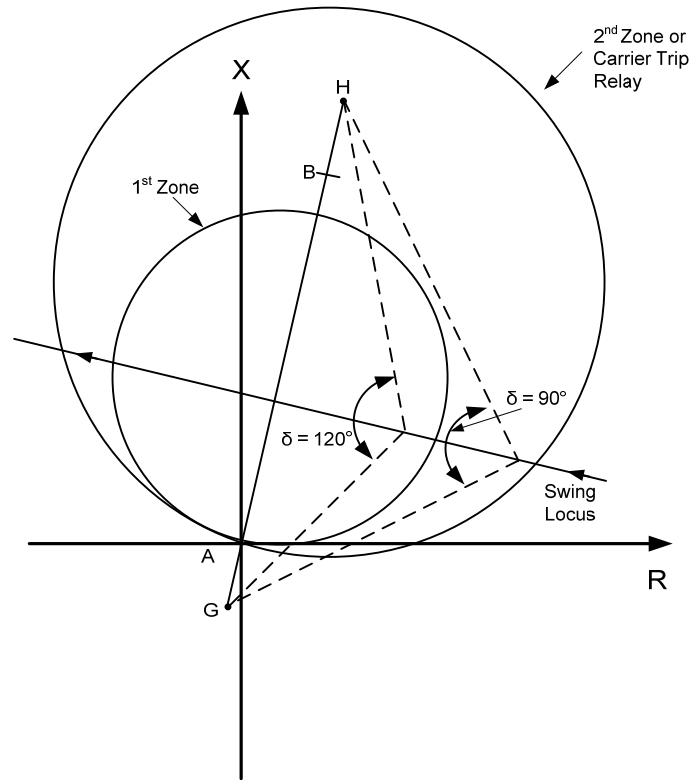
While it is evident from the illustration in Figure 7 that a swing locus can cause the apparent impedance to enter the relay element characteristic, resulting in operation of the element, the performance of distance elements is dependent to some extent on the relative magnitudes of system and line impedances. For example, if the line impedance is small compared to the system impedances, it is likely that the various distance zones will trip only on swings from which the system will not recover. This is illustrated in Figure 10 for the relay at Bus A (with three zones), showing that the swing locus will only enter the distance relay characteristics when the angular separation between sources  $E_G$  and  $E_H$  exceeds  $120^\circ$ . In the case illustrated, the angle must significantly exceed  $120^\circ$ . If the swing locus does not traverse zone 1 but traverses zone 2, the response of the line protection depends on the scheme used, as discussed in the sections below.



**Figure 10: Line Impedance is Small Compared to System Impedances**

When the line impedance is large compared to the system impedances, the distance relay elements could operate for swings from which the system could recover. This is illustrated in the example shown in Figure 11, where two zones are shown for clarity. It is evident that zone 2 will operate before the angular separation of the systems exceeds  $90^\circ$ , while zone 1 will operate before angular separation of  $120^\circ$  is reached. In this case the protection system is susceptible to tripping on a stable power swing unless the relay characteristic is modified or some form of blocking is provided to prevent tripping.

Time delayed zone 2 relays in a step distance scheme will trip if the locus resides within the characteristic for a time exceeding the delay setting.



**Figure 11: Line Impedance is Large Compared to System Impedances**

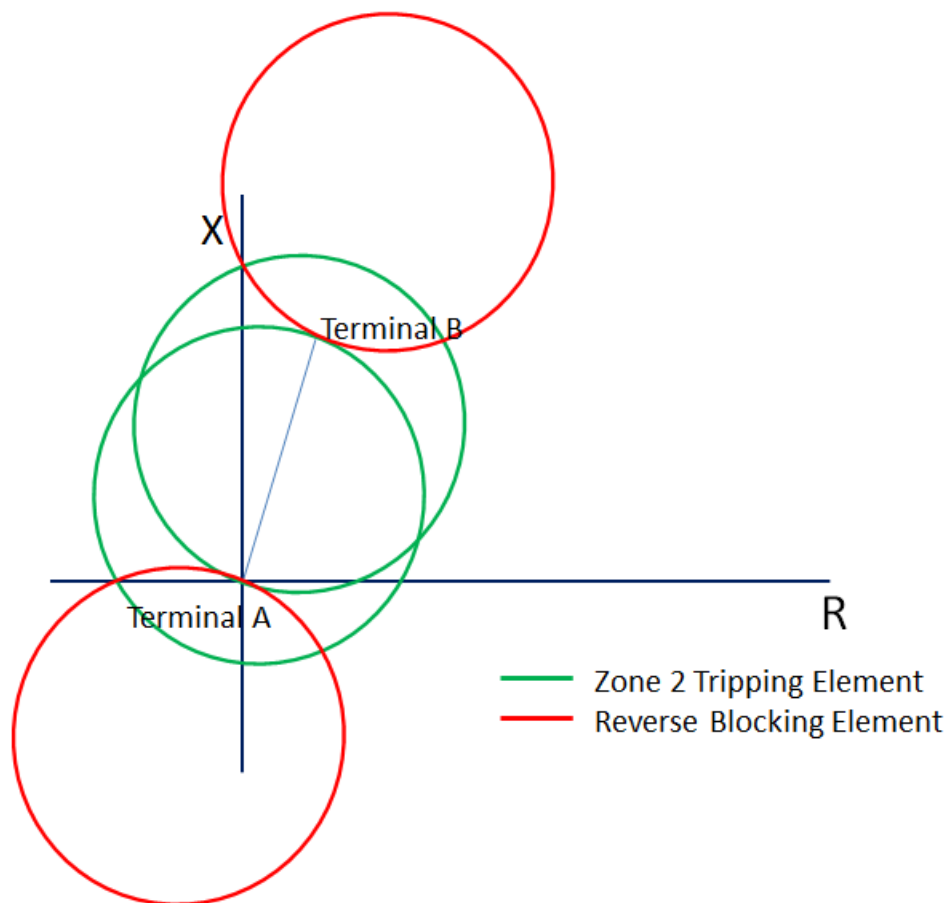
***Distance Relay Based Pilot Scheme Response to Power Swings***

Figure 12 Shows impedance elements as they are typically applied in directional comparison pilot schemes. The green characteristics represent zone 2 tripping elements. The tripping elements are used in both Directional Comparison Blocking (DCB) schemes, and Permissive Over Reaching (POR) schemes. The red characteristics represent blocking elements. They are used in all DCB schemes and many variations of POR schemes. Depending on the path of the impedance locus, power swings will affect the performance of DCB and POR schemes differently.

To cause a POR scheme to open a line, the impedance locus must be within both zone 2 tripping characteristics simultaneously. For POR schemes employing transient blocking functions, the locus must enter both tripping characteristics within a short time of each other, usually within about a power cycle. A DCB scheme will open at least one line terminal any time the locus enters either tripping characteristic, without also entering a blocking characteristic.

If the locus enters a blocking element, DCB schemes will transmit blocking signals, and POR terminals with blocking elements will not respond to received permissive signals. If a fault occurs on the protected line subsequent to the power swing locus entering the blocking element, a DCB scheme will trip. The performance of the POR terminal will depend on the system strength behind the terminal and on details of the permissive scheme logic associated with the blocking function.





**Figure 12: Directional Comparison Trip and Block**

### ***Response of Line Current Differential Protections***

With recent advancements in digital communication systems, the current differential principle has been effectively applied to line protection, providing good sensitivity for detection of line faults, including high resistance ground faults, while maintaining high degree of selectivity between internal and external faults. Many of these characteristics apply during power swing and out-of-step conditions. With the current differential principle measuring the current at one terminal of the line and computing the differential current with the current levels transmitted from the other terminal(s), the protection remains secure during a swing condition because the computed differential current remains below the threshold that would signify a fault. With increasing angular separation between the swinging systems, the current levels at each of the terminals increase beyond normal load levels, making the condition look like a through fault. Phase comparison protection systems exhibit performance similar to current differential protection systems.

One shortcoming in the characteristics of these current-only-based protections is that during some portion of the power swing, the protection could become insensitive to line faults. For example, if a line fault occurs at the electrical center of a two-terminal system when the angular separation between the swinging systems is  $180^\circ$ , the current levels at the two terminals are equal in magnitude and opposite in phase. This results in zero difference current, rendering the protection blind to this fault condition. However, as the power swing moves away from the electrical center (i.e., as the angular separation becomes different from  $180^\circ$ ), the difference current becomes non-zero, re-establishing the protection's sensitivity to detection of faults on the line being protected. Hence, the existence of the blind spot could delay the detection of some faults, as the angular separation needs to move from a less favorable to a more favorable value. The impact of this delay is system dependent, i.e., if the system slip is relatively fast, the delay could be minimal. For example, at slip frequency of 5 Hz, angular separation of  $180^\circ$  takes place in 100 ms. so the blind spot could last for less than 10 ms. The blind spot lasts for correspondingly longer periods of time when the slip frequency is reduced.

The shortcoming discussed above may be inconsequential in many applications; however, current-only-based protection systems have another shortcoming because backup protection is needed to address failures of the communication channel. In practice, a second independent current-based protection scheme could be applied to provide backup protection. However, a power system with no remote backup protection is susceptible to uncleared faults unless back-up protection is applied. Although a current-only-based protection system is secure for stable power swings and can be used on lines which require tripping on out-of-step conditions, an out-of-step tripping protection function is still required. Using an impedance-based back-up protection or out-of-step tripping function reintroduces the need to discriminate between stable and unstable power swings. The shortcomings of impedance-based out-of-step tripping functions can be mitigated by applying an integrated out-of-step tripping function that is supervised by non impedance-based algorithms; however, testing out-of-step tripping functions using simulated power system swings from the August 14, 2003 blackout investigation has identified susceptibility of some such protection systems to misoperate.

## Appendix C – Overview of Out-of-Step Protection Functions

### Power Swing and Out-of-Step Phenomenon

A power swing is a system phenomenon that is observed when the phase angle of one power source varies in time with respect to another source on the same network. The phenomenon occurs following any system perturbation, such as changes in load, switching operations, and faults, that alters the mechanical equilibrium of one or more machines. A power swing is stable when, following a disturbance, the rotation speed of all machines returns to synchronous speed. A power swing is unstable when, following a disturbance, one or more machines do not return to synchronous speed, thereby losing synchronism with the rest of the system.

### Basic Phenomenon Using the Two-Source Model

The simplest network for studying the power swing phenomenon is the two-source model, as shown in Fig. 12. The left source has a phase angle advance equal to  $\theta$ , and this angle will vary during a power swing. The right source represents an infinite bus, and its angle will not vary with time. This elementary network can be used to understand the behavior of more complex networks, although it has limitations when considering swings with multiple modes and time-varying voltages.

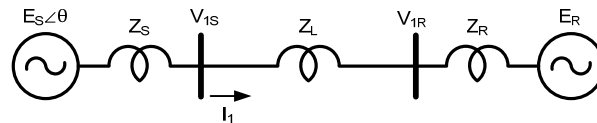


Figure 13: Two-source Equivalent Elementary Network

### Representation of Power Swings in the Impedance Plane

Assuming the sources have equal impedance amplitude, for a particular phase angle  $\theta$ , the location of the positive-sequence impedance ( $Z_1$ ) calculated at the left bus is provided by the following equation [1]:

$$Z_1 = \frac{V_{1S}}{I_1} = Z_T \cdot \frac{E_S \angle \theta}{E_S \angle \theta - E_R} - Z_S \quad (1)$$

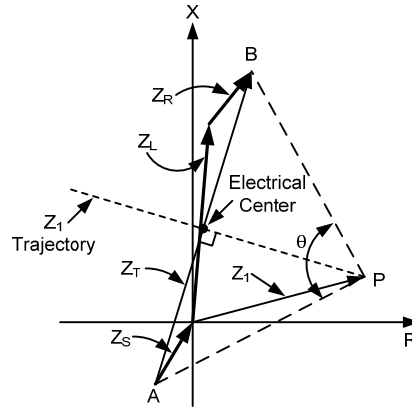
In (1),  $Z_T$  is the total impedance, as in:

$$Z_T = Z_S + Z_L + Z_R \quad (2)$$

Assuming the two sources are of equal magnitude, the  $Z_1$  impedance locus in the complex plane is given by (3).

$$Z_1 = \frac{Z_T}{2} \cdot \left( 1 - j \cot \frac{\theta}{2} \right) - Z_S \quad (3)$$

When the angle  $\theta$  varies, the locus of the  $Z_1$  impedance is a straight line that intersects the segment  $Z_T$  orthogonally at its middle point, as shown in Figure 14. The intersection occurs when the angular difference between the two sources is 180 degrees. When a generator torque angle reaches 180 degrees, the machine is said to have slipped a pole, reached an out-of-step (OOS) condition, or lost synchronism.

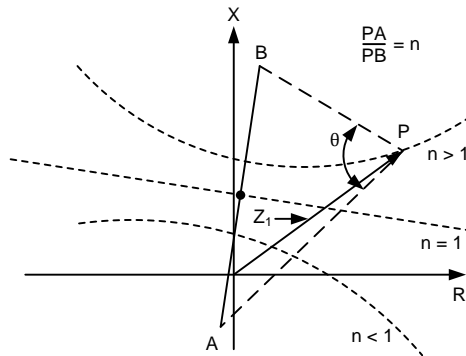


**Figure 14: Locus of the Z1 Impedance During a Power Swing with Sources of Equal Magnitude**

When the two sources have unequal magnitudes such that  $n$  is the ratio of  $E_S$  over  $E_R$ , the locus of the  $Z_1$  impedance trajectory will correspond to the circles shown in Figure 15. For any angle  $\theta$ , the ratio of the two segments joining the location of the extremity of  $Z_1$  (Point P) to the total impedance extremities A and B is equal to the ratio of the source magnitudes.

$$n = \frac{E_S}{E_R} = \frac{PA}{PB} \quad (4)$$

The precise equation for the center and radius of the circles as a function of the ratio  $n$  can be found in [1].



**Figure 15: Locus of the Z1 Impedance During a Power Swing with Sources of Unequal Magnitude**

It should be noted that synchronous generators are not ideal voltage sources as represented in the equivalent two-source model. Furthermore, the impact of automatic voltage regulators must be considered. During a power swing, the ratio of two power source magnitudes will not remain constant. Therefore, the resulting locus of the  $Z_1$  impedance will not follow a unique circle, with the trajectory depending upon the instantaneous voltage magnitude ratio.

### Rate of Change of the Positive-Sequence Impedance

Starting with (1) and assuming the two sources are of equal magnitude, the time derivative of the  $Z_1$  impedance is provided by (5) [2].

$$\frac{dZ_1}{dt} = -jZ_T \cdot \frac{e^{-j\theta}}{(1 - e^{-j\theta})^2} \cdot \frac{d\theta}{dt} \quad (5)$$

Assuming the phase angle has a linear variation with a slip frequency in radians per second given as:

$$\frac{d\theta}{dt} = \omega \quad (6)$$

and using the identity:

$$|1 - e^{-j\theta}| = 2 \cdot \sin \frac{\theta}{2} \quad (7)$$

the rate of change of the Z<sub>1</sub> impedance is finally expressed as:

$$\left| \frac{dZ_1}{dt} \right| = \frac{|Z_T|}{4 \cdot \sin^2 \frac{\theta}{2}} \cdot |\omega| \quad (8)$$

Equation (8) expresses the principle that the rate of change of the Z<sub>1</sub> impedance depends upon the sources, transmission line impedances, and the slip frequency, which, in turn, depend upon the severity of the power system disturbance.

As a consequence, any algorithm that uses the Z<sub>1</sub> impedance displacement speed in the complex plane to detect a power swing will depend upon the network impedances and the nature of the disturbance. Furthermore, the source impedances vary during the disturbance and typically are not introduced into the relay settings so the relay cannot usually predict the displacement speed.

## Out-of-Step Protection Functions

The detection of power swings is performed with two fundamental functions: the power swing blocking (PSB) function and the out-of-step tripping (OST) function [3]. The PSB function discriminates faults from stable or unstable power swings. The PSB function blocks relay elements that are prone to operate during stable or unstable power swings to prevent system separation in an indiscriminate manner. In addition, the PSB function unblocks previously blocked relay elements and allows them to operate for faults, in their zone of protection, that occur during an out-of-step (OOS) condition.

The OST function discriminates stable from unstable power swings and initiates network islanding during loss of synchronism. OST schemes are designed to protect the power system during unstable conditions, isolating unstable generators or larger power system areas from each other with the formation of system islands, to maintain stability within each island by balancing the generation resources with the area load.

To accomplish this, OST systems must be applied at preselected network locations, typically near the network electrical center. The isolated portions of the system are most likely to survive when network separation takes place at locations that preserve a close balance between load and generation. Since it is not always possible to achieve a load-generation balance, some means of shedding nonessential load or generation is necessary to avoid a collapse of the isolated portions of the power system.

Many relay systems are prone to operate during an OOS condition, which may result in undesired tripping. Therefore, OST systems may need to be complemented with PSB functions to prevent undesired relay system operations and to achieve a controlled system separation. When transmission separation schemes trip before fault protective relays operate, it may be desirable to not use the PSB function so that the fault protection can provide a last line of defense against asynchronous conditions.

Typically, the location of OST relay systems determines the location where system islanding takes place during loss of synchronism. However, it may be necessary in some systems to separate the network at a location other than the one where OST is installed. This is accomplished with the application of a transfer tripping type of scheme.

Uncontrolled tripping during OOS conditions can cause damage to power system breakers due to high transient overvoltages that appear across the breaker contacts when switching a line that contains the electrical center of a power swing. The maximum transient recovery voltage occurs when the relative phase angle of the two systems is 180° during the OOS condition. Circuit breaker opening angle should be considered in applying out-of-step protection for transmission circuits because opening at angles greater than 120 degrees may cause excess voltage stress on the circuit breaker. When selecting out-of-step relay settings it may be necessary to balance the potential breaker opening angle, the potential adverse impact of transmission voltage dips associated with a loss of synchronism, and the need to avoid tripping for recoverable swings.

## Power Swing Detection Methods

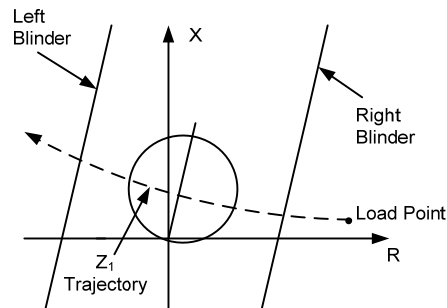
There are many different methods that are used to detect power swings, each with its strengths and drawbacks [4]. This section presents some of those detection methods.

### ***Conventional Rate of Change of Impedance Methods***

The rate of change of impedance methods are based on the principle that the  $Z_1$  impedance travels in the complex plane with a relatively slow speed, whereas during a fault,  $Z_1$  switches from the load point to the fault location almost instantaneously.

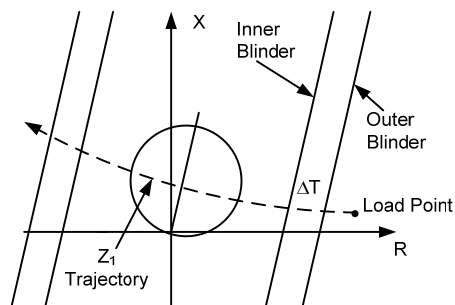
### ***Blinder Schemes***

Figure 16 shows an example of a single-blinder scheme. This scheme detects an unstable power swing when the time interval required to cross the distance between the right and left blinders exceeds a minimum time setting. The scheme allows for the implementation of OST on the way out of the zone and cannot be used for PSB because the mho characteristics will be crossed before the power swing is detected. This method is most commonly implemented in conjunction with generator protection and not line protection.



**Figure 16: Single-Blinder Characteristic**

Figure 17 shows an example of a dual-blinder scheme. During a power swing, the dual-blinder element measures the time interval  $\Delta T$  that it takes the  $Z_1$  trajectory to cross the distance between the outer and inner blinders. When this measured time interval is longer than a set time delay, a power swing is declared. The set time delay is adjusted so that it will be greater than the time interval measured during a fault and smaller than the time interval measured during the  $Z_1$  travel at maximum speed. Using the dual-blinder scheme, an OST scheme can be set up to either trip on the way into the zone or on the way out of the zone.

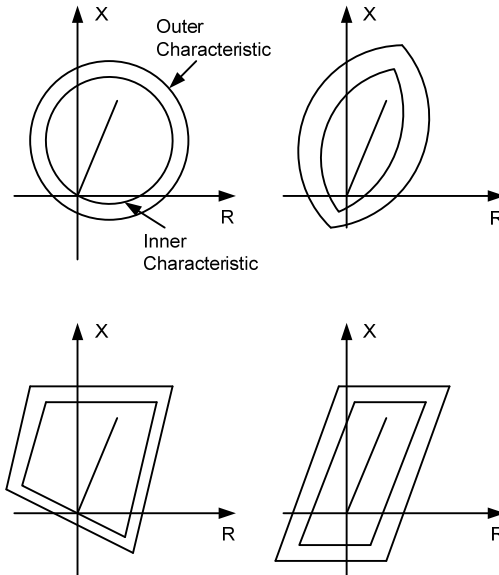


**Figure 17: Dual-Blinder Characteristic**

### ***Concentric Characteristic Schemes***

Concentric characteristics for the detection of power swings work on the same principle as dual-blinder schemes: after an outer characteristic has been crossed by the  $Z_1$  impedance, a timer is started and the interval of time before the inner characteristic is reached is measured. A power swing is detected when the time interval is longer than a set time delay.

Characteristics with various shapes have been used, as shown in Figure 18. The dual-quadrilateral characteristic represented at the bottom right of Figure 18 has been one of the most popular.

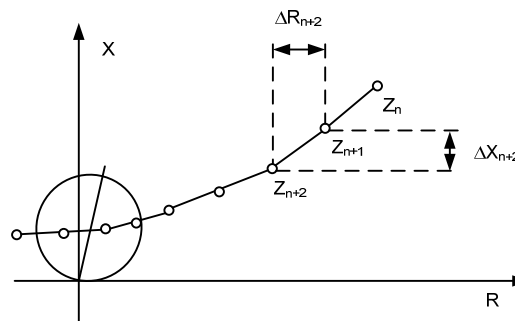


**Figure 18: Concentric Characteristic of Various Shapes**

### ***Nonconventional Power Swing Detection Methods***

#### **Continuous Impedance Calculation**

The continuous impedance calculation consists of monitoring the progression in the complex plane (Figure 19) of three modified loop impedances [5]. A power swing is declared when the criteria for all three loop impedances have been fulfilled: continuity, monotony, and smoothness. Continuity verifies that the trajectory is not motionless and requires that the successive  $\Delta R$  and  $\Delta X$  be above a threshold. Monotony verifies that the trajectory does not change direction by checking that the successive  $\Delta R$  and  $\Delta X$  have the same signs. Finally, smoothness verifies that there are no abrupt changes in the trajectory by looking at the ratios of the successive  $\Delta R$  and  $\Delta X$  that must be below some threshold.



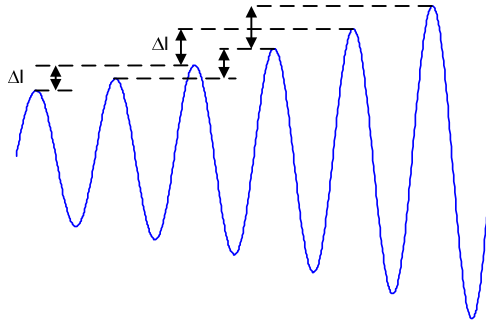
**Figure 19: Continuous Impedance Calculation**

The continuous impedance calculation is supplemented by a concentric characteristic to detect very slow-moving trajectories.

One of the advantages of the continuous impedance calculation is that it does not require any settings and can handle slip frequencies up to 7 Hz. It does not require, therefore, any power swing studies involving complex simulations.

**Continuous Calculation of Incremental Current**

During a power swing, both the phase voltages and currents undergo magnitude variations. The continuous calculation of the incremental current method computes the difference between the present current sample value and the value stored in a buffer 2 cycles before (see Figure 20). This method declares a power swing when the absolute value of the measured incremental current is greater than 5 percent of the nominal current and that this same condition is present for a duration of 3 cycles [6].



**Figure 20: Continuous Calculation of Incremental ΔI**

The main advantage of the continuous calculation of incremental current is that it can detect very fast power swings, particularly for heavy load conditions.

**R-Rdot OOS Scheme**

The R-Rdot relay for OST was devised specifically for the Pacific 500 kV ac intertie and was installed in the early 1980s. The R-Rdot relay uses the rate of change of resistance to detect an OOS condition.

An impedance-based control law for OOS detection is created by defining the following function [7-8]:

$$U_1 = (Z - Z_1) + T_1 \cdot \frac{dZ}{dt} \tag{9}$$

If we define a phase plane where the abscissa is the impedance magnitude and the ordinate is the rate of change of the impedance magnitude, (9) represents a switching line. An OOS trip is initiated when the switching line is crossed by the impedance trajectory from right to left. The effect of adding the impedance magnitude derivative is that the tripping will be faster at a higher impedance changing rate. At a small impedance changing rate, the characteristic is equivalent to the conventional OOS scheme.

In the R-Rdot characteristic, the impedance magnitude is replaced by the resistance measured at the relay location and the rate of change of the impedance magnitude is replaced by the rate of change of the measured resistance (see Figure 21). The advantage of this latter modification is that the relay becomes less sensitive to the location of the swing center with respect to the relay location.

$$U_1 = (R - R_1) + T_1 \cdot \frac{dR}{dt} \tag{10}$$

In the R-Rdot plane the switching line  $U_1$  is a straight line having slope  $T_1$ . System separation is initiated when output  $U_1$  becomes negative. For low separation rates (small  $dR/dt$ ), the performance of the R-Rdot scheme is similar to the conventional OST relaying schemes. However, higher separation rates ( $dR/dt$ ) would cause a larger negative value of  $U_1$  and initiate tripping much earlier. For a conventional OST relay without a rate of change of apparent resistance, augmentation is just a vertical line in the R-Rdot plane offset by the  $R_1$  relay setting parameter.



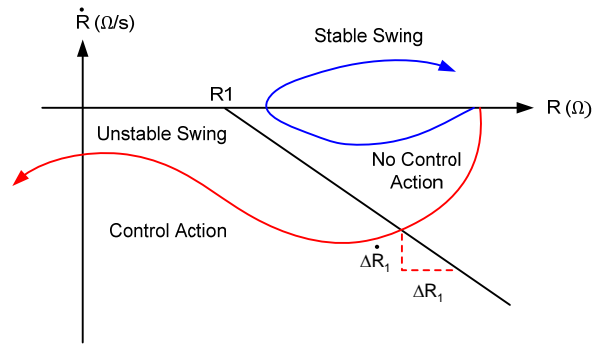


Figure 21: R-Rdot OOS Characteristic in the Phase Plane

**Rate of Change of Swing Center Voltage (SCV)**

SCV is defined as the voltage at the location of a two-source equivalent system where the voltage value is zero when the angles between the two sources are 180 degrees apart. Figure 22 illustrates the voltage phasor diagram of a general two-source system, with the SCV shown as the phasor from origin o to the point o'.

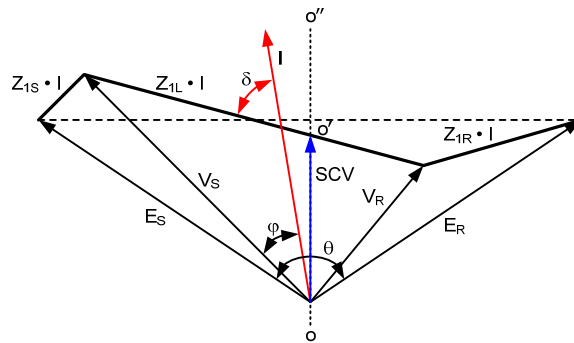


Figure 22: Voltage Phasor Diagram of a Two-Source System

When a two-source system loses stability and enters an OOS condition, the angle difference of the two sources,  $\theta(t)$ , increases as a function of time [2]. We can represent the SCV with (11), assuming equal source magnitudes in a two-source equivalent system,  $E = |E_S| = |E_R|$ .

$$SCV(t) = \sqrt{2}E \sin\left(\omega t + \frac{\theta(t)}{2}\right) \cdot \cos\left(\frac{\theta(t)}{2}\right) \quad (11)$$

SCV(t) is the instantaneous SCV that is to be differentiated from the SCV that the relay estimates. Equation (11) is a typical amplitude-modulated sinusoidal waveform. The first sine term is the base sinusoidal wave, or the carrier, with an average frequency of  $\omega + (1/2)(d\theta/dt)$ . The second term is the cosine amplitude modulation.

One popular approximation of the SCV obtained through the use of locally available quantities is as follows:

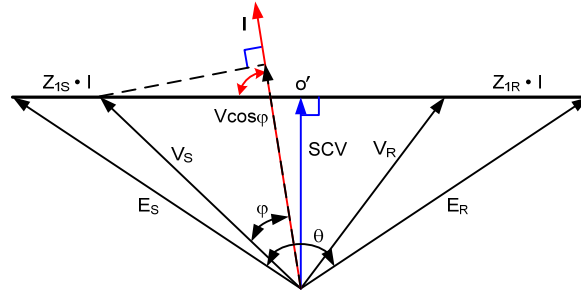
$$SCV \approx |V_S| \cdot \cos \phi \quad (12)$$

where:

$|V_S|$  is the magnitude of locally measured voltage.

$\phi$  is the angle difference between  $V_S$  and the local current, as shown in Figure 23.

The quantity of  $V \cos \phi$  was first introduced by Ilar for the detection of power swings [9].



**Figure 23:  $V\cos\phi$  is a Projection of Local Voltage,  $V_S$ , onto Local Current,  $I$**

In Figure 23, we can see that  $V\cos\phi$  is a projection of  $V_S$  onto the axis of the current,  $I$ . For a homogeneous system with the system impedance angles close to 90 degrees,  $V\cos\phi$  approximates well the magnitude of the SCV. For the purpose of power swing detection, it is the rate of change of the SCV that provides the main information of system swings. Therefore, some difference in magnitude between the system SCV and its local estimate has little impact in detecting power swings. We will, therefore, refer to  $V\cos\phi$  as the SCV in the following discussion.

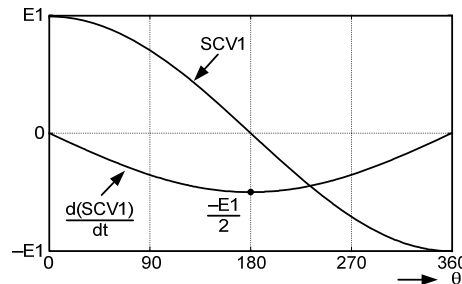
Using (11) and keeping in mind that the local SCV is estimated using the magnitude of the local voltage,  $V_S$ , the relation between the SCV and the phase angle difference,  $\theta$ , of two source voltage phasors can be simplified to the following:

$$SCV1 = E1 \cdot \cos\left(\frac{\theta}{2}\right) \quad (13)$$

In (13),  $E1$  is the positive-sequence magnitude of the source voltage,  $E_S$ , shown in Figure 23 and is assumed to be also equal to  $E_R$ . The time derivative of SCV1 is given by (14).

$$\frac{d(SCV1)}{dt} = -\frac{E1}{2} \sin\left(\frac{\theta}{2}\right) \frac{d\theta}{dt} \quad (14)$$

Equation (14) provides the relationship between the rate of change of the SCV and the two-machine system slip frequency,  $d\theta/dt$ . Equation (14) shows that the derivative of SCV1 is independent of power system impedances. Figure 24 is a plot of SCV1 and the rate of change of SCV1 for a system with a constant slip frequency of 1 radian per second.



**Figure 24: SCV1 and Its Rate of Change with Unity Source Voltage Magnitudes**

**Synchrophasor-Based OOS Relaying**

Consider the two-source equivalent network of Figure 13, and assume that the synchrophasors of the positive-sequence voltages are measured at the left and right buses as  $V_{1S}$  and  $V_{1R}$ .

The ratio of the two synchronized vectors is provided by the following equation:

$$\frac{V_{1S}}{V_{1R}} = \frac{\frac{Z_S}{Z_T} + (1 - \frac{Z_S}{Z_T}) \cdot k_E \angle \theta}{\frac{Z_S + Z_L}{Z_T} + (1 - \frac{Z_S + Z_L}{Z_T}) \cdot k_E \angle \theta} \quad (15)$$

where:

$k_E$  is the ratio of the magnitudes of the source voltages:

$$k_E = \frac{|E_S|}{|E_R|} \quad (16)$$

Assuming the source impedances are small with respect to the line impedance and the ratio  $k_E$  is close to 1, the ratio of the synchronized vectors can be approximated by unity for its magnitude and by the angle  $\theta$  between the two sources for its phase angle.

When using the two-source network equivalent, the result of (15) indicates that the ratio of the synchrophasors measured at the line extremities has a phase angle that can be approximated by the phase angle between the two sources. During a disturbance, the trajectory of the phase angle between the two phasors replicates the variation of the phase angle between the two machines. It is therefore possible to determine if an OOS condition is taking place when the measured phase angle trajectory becomes unstable [10].

Reference 10 presents the implementation of three functions based on synchrophasor measurements, the purpose of which is to trigger a network separation after a loss of synchronism has been detected. Positive-sequence voltage-based synchrophasors are measured at two locations of the network, assuming that the two-source equivalent can model the network. Following the measurement of the synchrophasors, two quantities are derived: the slip frequency  $S_R$ , which is the rate of change of the angle between the two measurements, and the acceleration  $A_R$ , which is the rate of change of the slip frequency. The three functions are defined as follows:

- Power swing detection is asserted when  $S_R$  is not zero and is increasing, which indicates  $A_R$  is positive and increasing.
- Predictive OST is asserted when, in the slip frequency against the acceleration plane, the trajectory falls in the unstable region (see Figure 25) defined by the condition:

$$A_R > 78\_Slope \cdot S_R + A_{Offset} \quad (17)$$

- OOS detection asserts when the absolute value of the angle difference between the two synchrophasors becomes greater than a threshold.

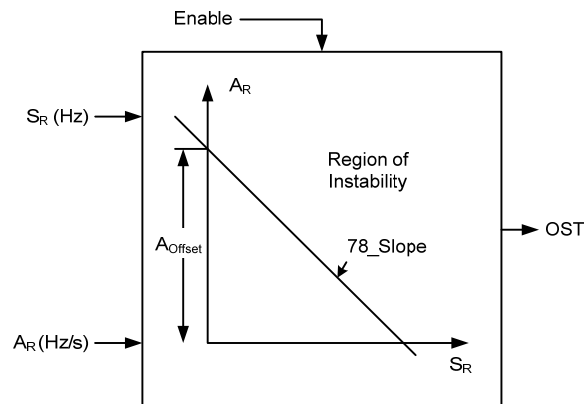


Figure 25: Predictive OST in the Slip-Acceleration Plane

A network separation or OST is initiated when the three functions are asserted.

### Out-of-Step Tripping Function

The OST function protects the power system during unstable conditions by isolating unstable generators or larger power system areas from each other by forming system islands. The main criterion is to maintain stability within each island. To accomplish this, OST systems should be applied at preselected network locations, typically near the network electrical center, to achieve a controlled system separation. The isolated portions of the system are most likely to survive when network separation takes place at locations in the network that preserve a close balance between load and generation.

Since it is not always possible to achieve a load-generation balance, some means of shedding load or generation is necessary to avoid a collapse of isolated portions of the power system.

OST systems may be complemented with PSB functions to prevent undesired relay system operations, equipment damage, and the shutdown of major portions of the power system. In addition, PSB blocking may be applied at other network locations to prevent system separation in an indiscriminate manner.

The selection of network locations for the placement of OST systems can best be obtained through transient stability studies covering many possible operating conditions. The maximum rate of slip is typically estimated from angular change versus time plots from stability studies. The stability study results are also used to identify the optimal location of OST and PSB relay systems, because the apparent impedance measured by OOS relay elements is a function of the MW and Mvar flows in transmission lines. Stability studies help identify the parts of the power system that impose limits on angular stability, generators that are prone to go out of step during system disturbances and those that remain stable, and groups of generators that tend to behave similarly during a disturbance.

Typically, the location of OST relay systems determines the location where system islanding takes place during loss of synchronism. However, in some systems, it may be necessary to separate the network at a location other than the one where OST is installed. This is accomplished with the application of a transfer tripping scheme. Current supervision may be necessary when performing OST at a different power system location than the location of OST detection to avoid issuing a tripping command to a circuit breaker at an unfavorable phase angle. Another important aspect of OST is to avoid tripping a line when the angle between systems exceeds the circuit breaker capability. Tripping during this condition imposes high stresses on the breaker and could cause breaker damage as a result of high recovery voltage across the breaker contacts, unless the breaker is rated for out-of-phase switching [11].

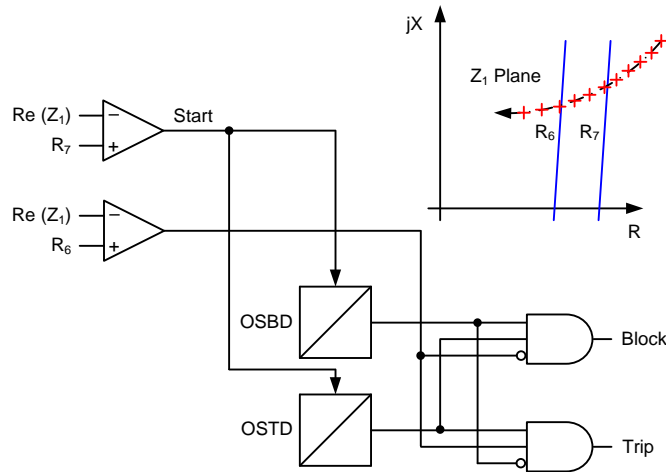
### ***Conventional OST Schemes***

Conventional OST schemes are based on the rate of change of the measured positive-sequence impedance vector during a power swing. The OST function is designed to differentiate between a stable and an unstable power swing and, if the power swing is unstable, to send a tripping command at the appropriate time to trip the line breakers. Traditional OST schemes use distance characteristics similar to the PSB schemes shown in Figures 16, 17, and 18. OST schemes also use a timer to time how long it takes for the measured impedance to travel between the two concentric characteristics. If the timer expires before the measured impedance vector travels between the two characteristics, the relay declares the power swing as an unstable swing and issues a tripping signal. Voltage supervision will increase the security of the OST scheme.

Figure 18 shows the dual-quadrilateral characteristic used for the detection of power swings. When the positive-sequence impedance enters the outer zone, two OOS logic timers start (OSTD and OSBD). Figure 26 illustrates how these timers operate.

There are two methods to implement out-of-step tripping. The first method is to trip on the way in (TOWI) when the OSTD timer expires and the positive-sequence impedance enters the inner zone. The second method is to select to trip on the way out (TOWO) when the OSTD timer expires and the positive-sequence impedance enters and then exits the inner zone. TOWO has the advantage of tripping the breaker at a more favorable time during the slip cycle when the two systems are close to an in-phase condition.

TOWI is necessary in some systems to prevent severe voltage dips and potential loss of loads. TOWI is typically applied in very large systems where the angular movement of one system with respect to another is very slow. It is also applied where there is a risk that transmission line thermal damage will occur if tripping is delayed until a more favorable angle exists between the two systems. However, it is necessary to evaluate potential trip conditions against the circuit breaker capability because the relay issues the tripping command to the circuit breaker when the relative phase angles of the two systems are approaching 180 degrees, which results in greater breaker stress than for OST applications that implement TOWO.



**Figure 26: Dual-Quadrilateral Timer Scheme**

One of the most important and difficult aspects of an OST scheme is the calculation of proper settings for the distance relay OST characteristics and the OST time-delay setting. Detailed dynamic simulation studies are recommended for cases where a transmission separation scheme is being developed for a specific disturbance scenario. These simulation studies can be used to address issues such as the maximum recoverable swing impedance and the adverse impact of the transient voltage dips associated with the swing. In some cases out of step settings may involve a tradeoff between minimizing transient voltage dips and avoid separation for recoverable swings.

The other difficult aspect of OST schemes is determining the appropriate time at which to issue a trip signal to the line breakers to avoid equipment damage and ensure personnel safety. To adequately protect the circuit breakers and ensure personnel safety, it may be necessary to prevent uncontrolled tripping during an OOS condition by restricting operation of the OST function to relative voltage angles between the two systems within the circuit breaker capability. Logic is included to allow delayed OST on the way out to minimize the possibility of breaker damage.

### ***Non-conventional OST Schemes***

The previously discussed OST setting complexities and the need for stability studies can be eliminated if the OST function is supervised by the output of a robust PSB function that makes certain that the network is experiencing a power swing and not a fault [4]. Using a reliable bit from the SCV PSB function for example to supervise an SCV-assisted OST function allows the implementation of a TOWO OST scheme without the need to perform any stability studies, which is a major advantage over traditional OST schemes.

The SCV-assisted OST function tracks and verifies that the measured  $Z_1$  impedance trajectory crosses the complex impedance plane from right to left, or from left to right, and issues a TOWO at a desired phase angle difference between sources. Verifying that the  $Z_1$  impedance enters the complex impedance plane from the left or right side and making sure it exits at the opposite side of the complex impedance plane ensures that the function operates only for unstable power swings. On the contrary, traditional OST schemes that do not track the  $Z_1$  impedance throughout the complex impedance plane may operate for a stable swing that was not considered during stability studies and happens to cross the inner OST characteristic.

Four resistive and four reactive blinders are still used in the SCV-assisted OST scheme, as shown in Figure 18. However, the settings for these blinders are easy to calculate when applying TOWO. The outermost OST resistive blinders can be placed around 80 to 90 degrees in the complex impedance plane, regardless of whether a stable power swing crosses these blinders or whether the load impedance of a long, heavily loaded line encroaches upon them. The inner OST resistive blinder can be set anywhere from 120 to 150 degrees. In addition, there are no OST timer settings involved in the SCV-assisted OST scheme.

To apply TOWI, stability studies are still required to ensure that no stable swings will cause the operation of the inner OST characteristic.

## Issues Associated With the Concentric or Dual-Blinder Methods

### ***Impact of System Impedances***

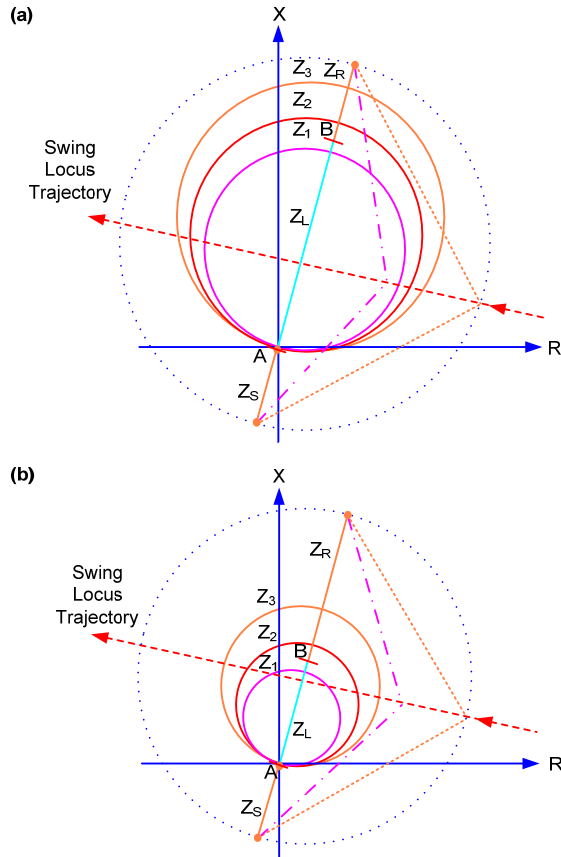
To guarantee enough time to carry out blocking of the distance elements after a power swing is detected, the inner impedance of the blinder element must be placed outside the largest distance element for which blocking is required. In addition, the outer blinder impedance element should be placed away from the load region to prevent PSB logic operation caused by heavy loads, thus establishing an incorrect blocking of the line mho tripping elements. The previous requirements are difficult to achieve in some applications, depending on the relative line impedance and source impedance magnitudes (see Figure 27).

Figure 27a depicts a system in which the line impedance is large compared with system impedances (strong source), and Figure 27b depicts a system in which the line impedance is much smaller than the system impedances (weak source).

We can observe from Figure 27a that the swing locus could enter the zone 2 and zone 1 relay characteristics during a stable power swing from which the system could recover. For this particular system, it may be difficult to set the inner and outer PSB blinder elements, especially if the line is heavily loaded, because the necessary PSB settings are so large that the load impedance could establish incorrect blocking. To avoid incorrect blocking resulting from load, lenticular distance relay characteristics, load encroachment, or blinders that restrict the tripping area of the mho elements have been applied in the past. On the other hand, the system shown in Figure 27b becomes unstable before the swing locus enters the zone 2 and zone 1 mho elements, and it is relatively easy to set the inner and outer PSB blinder elements.

Another difficulty with the blinder characteristic method is the separation between the inner and outer PSB blinder elements and the timer setting that is used to differentiate a fault from a power swing. These settings are not difficult to calculate, but depending on the system under consideration, it may be necessary to run extensive stability studies to determine the fastest power swing and the proper PSB blinder element settings. The rate of slip between two systems is a function of the accelerating torque and system inertias. In general, a relay cannot determine the slip analytically because of the complexity of the power system. However, by performing system stability studies and analyzing the angular excursions of systems as a function of time, it is possible to estimate an average slip in degrees per second or cycles per second. This approach may be appropriate for systems where slip frequency does not change considerably as the systems go out of step. However, in many systems where the slip frequency increases considerably after the first slip cycle and on subsequent slip cycles, a fixed impedance separation between the blinder PSB elements and a fixed time delay may not be suitable to provide a continuous blocking signal to the mho distance elements.

In a complex power system, it is very difficult to obtain the proper source impedances that are necessary to establish the blinder and PSB delay timer settings [3]. The source impedances vary continuously according to network changes, such as additions of new generation and other system elements. The source impedances could also change drastically during a major disturbance and at a time when the PSB and OST functions are called upon to take the proper actions. Normally, very detailed system stability studies are necessary to consider all contingency conditions in determining the most suitable equivalent source impedance to set the PSB or OST functions.



**Figure 27: Effects of Source and Line Impedances on the PSB Function**

### ***Impact of Heavy Load on the Resistive Settings of the Quadrilateral Element***

References [3] and [4] recommend setting the concentric dual-quadrilateral power swing characteristic inside the maximum load condition but outside the maximum distance element reach desired to be blocked. In long-line applications with a heavy load flow, following these settings guidelines may be difficult, if not impossible. Fortunately, most numerical distance relays allow some form of programming capability to address these special cases. However, in order to set the relay correctly, stability studies are required; a simple impedance-based solution is not possible.

The approach for this application is to set the power swing blinder such that it is inside the maximum load flow impedance and the worst-case power swing impedance. Using this approach can result in cutting off part of the distance element characteristic. Reference [11] provides additional information and logic to address the issues of PSB settings on heavily loaded transmission lines.

### **OOS Relaying Philosophy**

There are many different power swing detection methods that can be used to protect a power system from OOS conditions, each of which has its own benefits and drawbacks. While the OOS relaying philosophy is simple, it is often difficult to implement in a large power system because of the complexity of the system and the different operating conditions that must be studied.

The recommended approach for OOS relaying application is summarized below:

- Perform system transient stability studies to identify system stability constraints based on many operating conditions and stressed-system operating scenarios. The stability studies will help identify the parts of the power system that impose limits to angular stability, generators that are prone to go OOS during system disturbances, and those that remain stable. The results of stability studies are also used to identify the optimal location of OST and PSB protection relay systems.

- Determine the locations of the swing loci during various system conditions and identify the optimal locations to implement the OST protection function. The optimal location for the detection of the OOS condition is near the electrical center of the power system. However, it is necessary to determine that the behavior of the impedance locus near the electrical center would facilitate the successful detection of OOS.
- Determine the optimal location for system separation during an OOS condition. This will typically depend on the impedance between islands, the potential to attain a good load/generation balance, and the ability to establish stable operating areas after separation. High impedance paths between system areas typically represent appropriate locations for network separation.
- Establish the maximum rate of slip between systems for OOS timer setting requirements, as well as the minimum forward and reverse reach settings required for successful detection of OOS conditions. The swing frequency of a particular power system area or group of generators relative to another power system area or group of generators does not remain constant. The dynamic response of generator control systems, such as automatic voltage regulators, and the dynamic behavior of loads or other power system devices, such as SVCs and FACTS, can influence the rate of change of the impedance measured by OOS protection devices.

## References

- [1] C. R. Mason, *The Art and Science of Protective Relaying*. John Wiley & Sons, Inc., New York, 1956.
- [2] G. Benmouyal, D. Hou, and D. Tziouvaras, "Zero-setting Power-Swing Blocking Protection ", proceedings of the 31st Annual Western Protective Relay Conference, Spokane, WA, October 2004.
- [3] D. Tziouvaras, and D. Hou, "Out-of-Step Protection Fundamentals and Advancements," proceedings of the 30th Annual Western Protective Relay Conference, Spokane, WA, October 2003.
- [4] N. Fischer, G. Benmouyal, Da. Hou, D. Tziouvaras, J. Byrne-Finley, and B. Smyth, "Tutorial on Power Swing Blocking and Out-of-Step Tripping," proceedings of the 39th Annual Western Protective Relay Conference, Spokane, WA, October 2012.
- [5] J. Holbach, "New Blocking Algorithm for Detecting Fast Power Swing Frequencies," proceedings of the 30th Annual Western Protective Relay Conference, Spokane, WA, October 2003.
- [6] Q. Verzosa, "Realistic Testing of Power Swing Blocking and Out-of-Step Tripping Functions," proceedings of the 38th Annual Western Protective Relay Conference, Spokane, WA, October 2011.
- [7] C. W. Taylor, J. M. Haner, L. A. Hill, W. A. Mittelstadt, and R. L. Cresap, "A New Out-of-Step Relay With Rate of Change of Apparent Resistance Augmentation," *IEEE Transactions on Power Apparatus and Systems*, Vol. PAS-102, No. 3, March 1983.
- [8] J. M. Haner, T. D. Laughlin, and C. W. Taylor, "Experience with the R Rdot Out-of-Step Relay," *IEEE Transactions on Power Delivery*, Vol. 1, No. 2, April 1986.
- [9] F. Ilar, "Innovations in the Detection of Power Swings in Electrical Networks," Brown Boveri Publication CH-ES 35-30.10E, 1997.
- [10] A. Guzmán, V. Mynam, and G. Zweigle, "Backup Transmission Line Protection for Ground Faults and Power Swing Detection Using Synchrophasors," proceedings of the 34th Annual Western Protective Relay Conference, Spokane, WA, October 2007.
- [11] J. Mooney and N. Fischer, "Application Guidelines for Power Swing Detection on Transmission Systems," proceedings of the 32nd Annual Western Protective Relay Conference, Spokane, WA, October 2005.
- [12] W. A. Elmore, "The Fundamentals of Out-of-Step Relaying," proceedings of the 34th Annual Conference for Protective Relay Engineers, Texas A&M University, College Station, TX, April 1981.
- [13] IEEE Power System Relaying Committee, Working Group D-6 Report, *Power Swing and Out-of-Step Considerations on Transmission Lines*. Available: <http://www.pes-psrc.org/>.



## Appendix D – Potential Methods to Demonstrate Security of Protective Relays

---

### IEEE PSRC WG D6 Method

Appendix A of the IEEE PSRC WG D6 paper on power swing considerations presents the process of reducing a complex power system to a two source equivalent system connected by a single transmission line in parallel with a second line which is the equivalent of the remaining transmission system connecting the two sources. The two source equivalent system will be accurate for faults anywhere on the retained transmission line. It can also be used to determine whether the swing center of the two systems lies within the retained transmission. The usefulness of the method of determining whether the swing center is contained within the line depends on the probability of the actual power system to consist of two coherent systems of generators connected by the modeled system.

This method was applied to a system in the northwest portion of the eastern interconnection. The system consists of a double circuit ring of 345 kV lines around an underlying 115 kV system. Large generation stations are located at several points around the ring. The 345 kV lines connect with other systems from the east, southeast, and southwest parts of the ring. When applied to these connections, the method of Appendix A predicts that the swing center will pass through these lines. In fact this system has been observed to have at least one of these swing centers, and the system of generators around the ring will behave as a coherent set relative to the connected system across the ties.

The method also predicts that virtually every 115kV line within the 345kV ring will also contain the swing center when the system is reduced to a two source equivalent. It is extremely unlikely to separate into two independent sets of coherent generators within this ring. In his paper “The Fundamentals of Out-Of-Step Relaying”, Walt Elmore presents this method and states, “When more than a line or two are to be analyzed, it is virtually impossible to use the method.”

When applied to the 345kV lines making up the double circuit ring, the method shows that for a majority of them the swing center will not pass through them, but will fall just outside the line. For the most part, these lines are fairly short with many interconnections. An assessment was not performed examining the effect of taking two or three lines out, but this likely would result in bringing the center into one end of the line. With several of these lines out the possibility of two sets of generators swinging relative to each other increases.

For the most part, the Appendix A method looks useful for identifying swing centers between relatively independent systems connected by a small number of ties.

### Calculation Methods based on the Graphical Analysis Method

A classical method to determine if a particular relay is subject to tripping during a power swing is discussed in Appendix A. In this method, the system consists of the line where the relay is applied with a system equivalent generator and impedance at each end of a particular line (see Figure 6). For this system, assuming equal voltage magnitudes for the equivalent generator, a power swing traverses along the perpendicular bisector of the total system impedance. Figure 6 shows a graphical interpretation of this. In Figure 7, the dashed line is the path the impedance traverses during the power swing and the angle  $\delta$  is the angle between the two equivalent generator sources. The impedance seen at relay terminal A is to the right of the relay's impedance characteristic prior to the onset of the power swing. As a stable power swing occurs, the angle between the two equivalent generators increases causing the impedance to move to the left along the dashed line. When the system stabilizes, the power swing will switch directions (this can take a significant amount of time) and move to the right along the dashed line, oscillate, and then end at a new stable operating point. Depending on the size of the overall system impedance, the length of the line, and the reach of the impedance relay, the stable power swing may or may not fall within the relay characteristic. For cases where the relay's impedance characteristic intersects the electrical center of the system, the power swing will enter the relay's characteristic at some value of the angle  $\delta$ . When the power swing enters the relay's characteristic, the relay will trip quickly if it is a zone 1 type relay. Because stable power swings may be slower to reverse direction than it takes a typical time delayed relay to trip, time delayed zones must also be evaluated.

As stated in this report and many others it is generally accepted based on many power swing studies that if a power swing traverses beyond an angle  $\delta$  greater than or equal to 120 degrees, the power swing will not be stable. This 120 degree angle is often called the “critical angle.” The logic behind the general acceptance of 120 degrees as the critical angle for

stability is discussed above in Appendix A. Two potential methods are presented to screen relays for susceptibility to stable power swings based on the use of the 120 degree critical angle.

### Method 1

The first method uses an equivalent circuit based on the system shown in Figure 28. A calculation is made of the impedance seen at a relay terminal when the difference between the generator angles in the equivalent system described above is 120 degrees. If the impedance calculated does not fall within the relays impedance characteristic, it is not susceptible to tripping for a stable power swing. The discussion that follows pertains to a mho type relay characteristic, but the same process could be used for other characteristics.

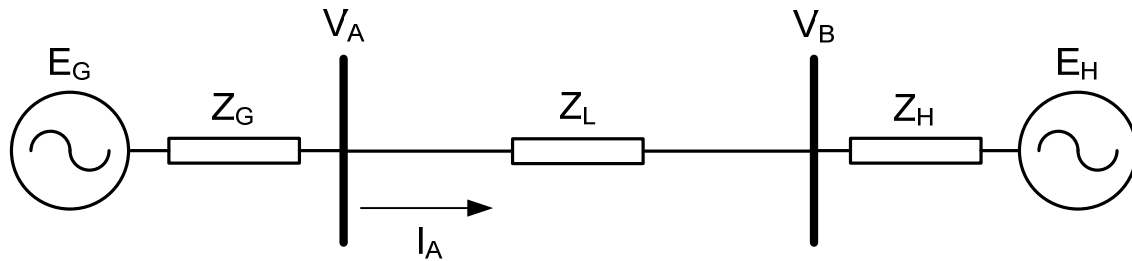


Figure 28: Two-Machine Equivalent of a Power System

Since this calculation does not use a computer model, various parameters must be established:

- It is a reasonable and conservative assumption to assume that the voltage at the equivalent generator terminals is 1.05 per unit even under these severe conditions.
- The angle between the generator voltages is set to the 120 degree critical angle.
- Line and equivalent generator impedance angles are set to 90 degrees. This causes minimal variation in the calculation and simplifies the calculation.
- The equivalent generator impedances can be calculated using a fault study program and calculated with the line under study out of service.

Given these parameters the allowable impedance for the relay (circular mho type) at terminal A can be calculated as follows. Referring to Figure 28:

$$V_A = E_G - I_A * Z_G \text{ and}$$

$$I_A = (E_G - E_H) / (Z_G + Z_L + Z_H) \text{ and}$$

$$Z_A = V_A / I_A = Z_{AMAG} @ Z_{Aang} \text{ and}$$

$$Z_{Aallowable} = Z_{AMAG} / (\cos(MTA - Z_{Aang}))$$

Similarly, the  $Z_{allowable}$  at the B terminal can be calculated:

$$V_B = E_H - I_H * Z_H \text{ and}$$

$$I_B = -I_A$$

$$Z_B = V_B / I_B = Z_{BMAG} @ Z_{Bang} \text{ and}$$

$$Z_{Ballowable} = Z_{BMAG} / (\cos(MTA - Z_{Bang}))$$

An example of some  $Z_{allowable}$  calculations using this method for a 345kV system is shown below:

**Table 1: Examples of  $Z_{\text{allowable}}$  for a Sample 345 kV System Using Method 1**

System Angle (degrees)		System and Line Impedance (Ohms)			$Z_{\text{A allowable}}$				$Z_{\text{B allowable}}$			
$E_G$	$E_H$	$Z_G$	$Z_L$	$Z_H$	90° MTA	85° MTA	80° MTA	75° MTA	90° MTA	85° MTA	80° MTA	75° MTA
0	120	5	5	10	11.7	13.0	14.9	17.5	11.7	10.6	9.8	9.2
0	120	13	5	10	66.3	227.4	-158.4	-58.9	16.3	15.1	14.3	13.6
0	120	20	20	10	46.7	62.7	96.5	213.3	46.7	37.4	31.4	27.2
0	120	5	5	60	43.6	46.5	50.3	55.1	43.6	41.3	39.6	38.2

Note 1) A negative number means that no stable power swings will fall within the zone.

Note 2) If  $E_G = 120$  and  $E_H = 0$ , then the  $Z_A$  allowable impedances shown become the  $Z_B$  allowable impedances and vice versa.

This method is conservative for a number of reasons:

- This simplified calculation assumes a large stable power swing with the system in a normal configuration. Tripping for a stable power swing is more likely with the system weakened. Weakening the system increases the allowable impedance for a given line.
- This simplified calculation estimates the equivalent system impedances from the fault model which uses sub-transient reactances for generators. Power Swings are longer time phenomena and use transient reactances which are larger ( $X''_d \sim 0.7X'_d$ ).
- It does not include the effects of parallel paths to the line under test (i.e., it ignores the transfer impedance – see Method 2). Including parallel paths allows for a higher distance zone setting. This method essentially assumes that the line under test is the only line connecting two systems.

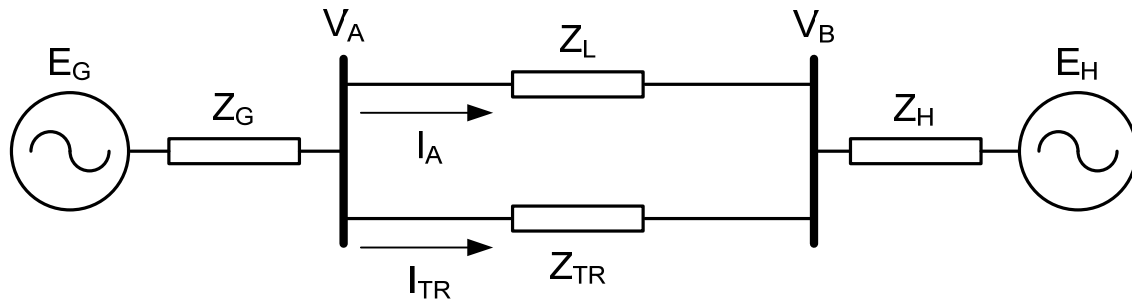
Some conclusions that are generally known can also be drawn from this method:

- Shorter lines with shorter relay settings are less susceptible to tripping on power swings than longer lines with larger settings.
- Zone 1 relays on short lines (i.e. lines < ~ 40 miles at 345kV and probably greater) are basically immune to tripping on stable power swings. Overreaching distance zones (zone 2, zone 3, etc.) with reaches equivalent to this short line zone 1 reach are also basically immune to tripping on stable power swings. Note that distances vary proportionally with voltage level (lower at lower voltages and higher at higher voltage levels).
- As source impedances change due to system configuration changes, the susceptibility of a mho relay to trip for a stable power swing can vary a great deal.
- Depending on the direction of power flow during the stable swing (into or out of the relay terminal), the susceptibility of a mho relay to trip for a stable power swing can vary a great deal.
- This method will screen out backup zones in some cases, but does not screen out backup zones well, even on highly connected systems where stable power swings are less likely or highly unlikely.

## Method 2

The second method uses an equivalent circuit based on the system shown in Figure 29. A calculation of the impedance seen at a relay terminal when the difference between the generator angles in the equivalent system described above is 120

degrees is made. If the impedance calculated does not fall within the relays impedance characteristic, it is not susceptible to tripping for a stable power swing. The discussion that follows pertains to a mho type relay characteristic, but the same process could be used for other characteristics.



**Figure 29: Two-Machine Equivalent of a Power System with Parallel System Transfer Impedance**

Since this calculation does not use a computer model, various parameters must be established:

- It is a reasonable and conservative assumption to assume that the voltage at the equivalent generator terminals is 1.05 per unit even under these severe conditions.
- The angle between the generator voltages is set to the 120 degree critical angle.
- Line and equivalent generator impedance angles are set to 90 degrees. This causes minimal variation in the calculation and simplifies the calculation.
- The equivalent generator impedances and transfer impedances can be obtained from a fault study program.

Given these parameters the allowable impedance for the relay (circular mho type) at terminal A can be calculated as follows. Referring to Figure 29:

$$V_A = E_G - I_{TOTAL} * Z_G \text{ and}$$

$$I_{TOTAL} = (E_G - E_H) / (Z_G + Z_{eq} + Z_H) \text{ where } Z_{eq} = (Z_L * Z_{TR}) / (Z_L + Z_{TR}) \text{ and}$$

$$I_A = I_{TOTAL} * (Z_{TR} / (Z_{TR} + Z_L))$$

$$Z_A = V_A / I_A = Z_{AMAG} @ Z_{Aang} \text{ and}$$

$$Z_{Aallowable} = Z_{AMAG} / (\cos(MTA - Z_{Aang}))$$

Similarly, the Zallowable at the B terminal can be calculated:

$$V_B = E_H - I_H * Z_H \text{ and}$$

$$I_B = -I_A$$

$$Z_B = V_B / I_B = Z_{BMAG} @ Z_{Bang} \text{ and}$$

$$Z_{Ballowable} = Z_{BMAG} / (\cos(MTA - Z_{Bang}))$$

An example of some Zallowable calculations using this method for a 345kV system is shown below:

**Table 2: Examples of  $Z_{\text{allowable}}$  for a Sample 345 kV System Using Method 2**

System Angles		System, Line, and Transfer Impedances				$Z_{\text{A allowable}}$				$Z_{\text{B allowable}}$			
$E_{\text{G}}$	$E_{\text{H}}$	$Z_{\text{G}}$	$Z_{\text{H}}$	$Z_{\text{TR}}$	$Z_{\text{L}}$	90° MTA	85° MTA	80° MTA	75° MTA	90° MTA	85° MTA	80° MTA	75° MTA
0	120	5	5	10	10	20.0	23.7	29.2	38.6	17.5	16.3	15.4	14.7
0	120	5	5	50	10	13.1	14.8	17.1	20.5	12.7	11.7	10.9	10.3
0	120	5	5	100	10	12.4	13.9	16.0	18.9	12.2	11.2	10.4	9.7
0	120	5	5	500	10	11.8	13.2	15.1	17.8	11.8	10.7	9.9	9.3
0	120	13	5	10	10	-61.8	-44.7	-35.2	-29.3	27.8	26.2	25.0	24.0
0	120	13	5	50	10	416.3	-139.7	-60.0	-38.4	18.5	17.3	16.4	15.6
0	120	13	5	100	10	123.9	-489.1	-82.4	-45.2	17.4	16.2	15.3	14.6
0	120	20	20	10	10	140.0	257.7	1696.9	-369.5	52.0	47.8	44.6	42.1
0	120	20	20	50	10	61.1	86.7	151.4	615.4	40.1	34.7	30.7	27.7
0	120	20	20	100	10	53.6	74.0	120.9	337.1	41.7	35.0	30.4	27.0
0	120	5	5	10	60	76.9	86.7	100.2	119.8	83.5	79.4	76.3	74.0
0	120	5	5	50	60	48.7	52.5	57.4	63.9	51.6	48.9	46.9	45.4
0	120	5	5	100	60	46.0	49.4	53.7	59.3	47.6	45.1	43.2	41.8

Note 1) A negative number means that no stable power swings will fall within the zone.

Note 2) If  $E_{\text{G}} = 120$  and  $E_{\text{H}} = 0$ , then the  $Z_{\text{A}}$  allowable impedances shown become the  $Z_{\text{B}}$  allowable impedances and vice versa.

This method is conservative for a number of reasons:

- This simplified calculation assumes a large stable power swing with the system in a normal configuration. Tripping for a stable power swing is more likely with the system weakened. Weakening the system increases the allowable impedance for a given line.
- This simplified calculation estimates the equivalent system impedances from the fault model which uses sub-transient reactances for generators. Power Swings are longer time phenomena and use transient reactances which are larger ( $X''_d \sim 0.7X'_d$ ).

Some conclusions that are generally known can also be drawn from this method:

- If the transfer impedance is high, this method is essentially the same as method 1. If the transfer impedance is infinite, this method is equivalent to method 1.

- If the transfer impedance is low as in a more interconnected system, this method shows that a greater relay reach can be set before a relay will trip during a stable power swing versus method 1. This method is a more accurate representation of the power system and hence is more accurate than method 1. However, as transfer impedances change due to system configuration changes, the susceptibility of a mho relay to trip for a stable power swing also changes.
- Shorter lines with shorter relay settings are less susceptible to tripping on power swings than longer lines with larger settings.
- Zone 1 relays on short lines (i.e. lines < ~ 40 miles at 345kV and probably greater) are basically immune to tripping on stable power swings. Overreaching distance zones (zone 2, zone 3, etc.) with reaches equivalent to this short line zone 1 reach are also basically immune to tripping on stable power swings. Note that distances vary with voltage level (lower at lower voltages and higher at higher voltage levels).
- As source impedances change due to system configuration changes, the susceptibility of a mho relay to trip for a stable power swing can vary a great deal.
- Depending on the direction of power flow during the stable swing (into or out of the relay terminal), the susceptibility of a mho relay to trip for a stable power swing can vary a great deal.
- This method will screen out backup zones better than method 1.

Like the methods for loadability in PRC-023, both method 1 and method 2 address a single impedance relay or a single relay element. This method does not provide a calculation for a composite scheme like a Permissive Overreach with Transfer Trip scheme where two relays may be required to pick up to cause a trip.

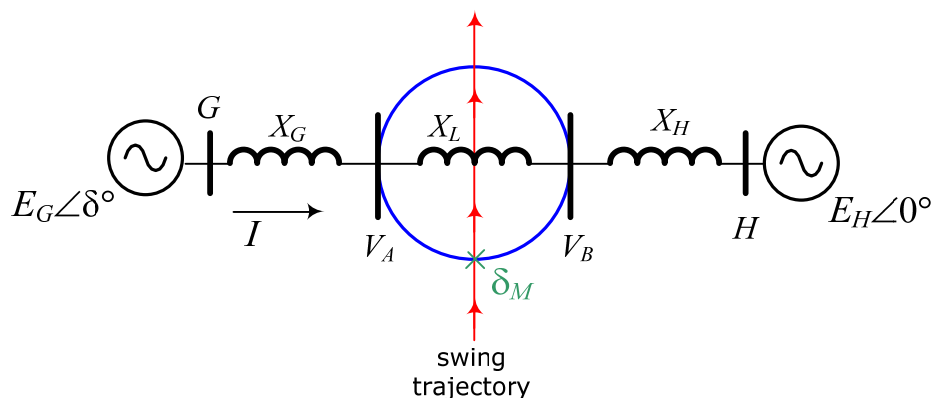
## Voltage Dip Screening Method

Although there are number of successful power swing detection methods, the goal of the voltage dip method is to establish a reliable screening tool easily applicable in transient stability planning studies. Transient stability planning studies evaluate many contingencies and monitor performance of many variables of the Bulk-Power System in order to demonstrate compliance with applicable standards and criteria. Due to the comprehensive nature of the analysis, a practical screening method that flags potential power swing problems is essential.

It is well known that the most accurate method of identifying stable/unstable power swing requires a model of the protection system (susceptible to stable and unstable power swings) in place and detailed simulation of the event that produces the power swing. A plot of apparent impedance trajectory during the system disturbance against an appropriate relay characteristic determines the power swing status. In large scale transient stability planning studies where many contingencies are considered, that approach requires an effort of modeling and maintaining many relay characteristics and recording many apparent impedance channels. The proposed screening method seeks a reliable way of identifying potential power swings with minimal burden on additional modeling as part of the analysis.

While the power swing is the result of angular separation between units or coherent groups of units that oscillate against each other, finding the coherent groups requires multiple simulation runs. In power swing identification primary question is whether the swing is stable or not and the subsequent question is to identify which units drive the power swing. As a result of coherent units swings, the transmission voltage magnitude gets low near the center of the swing. Therefore, since transmission voltages are monitored in transient stability planning studies and voltage performance is subject to planning criteria in many areas (WECC Transmission planning standard and ISO-NE voltage sag guidelines), post-disturbance voltage dips can be used as a potential screening tool for power swing identification.

In order to establish a theory behind the proposed method, a two-source equivalent is examined first. Since the system has only one path between two sources, the idea is to study a range of system conditions subject to the power swing and then test the voltage dip criteria on the transmission line terminals. The two-source system in Figure 30 is analyzed. The system is assumed to be symmetrical (i.e., the source terminal voltages are equal in magnitude,  $|E_G|=|E_H|$ ), during the power swing, the electrical center occurs in the middle of the impedance between two sources.



**Figure 30: Two-source equivalent system**

The following assumptions have been made regarding the system in Figure 30:

- 1) Source and line resistances are neglected
- 2) Distance relay characteristic is a circle with diameter equal to 100 percent of line reactance
- 3) Relay maximum torque angle is equal to line angle
- 4) For simplicity it will be assumed that  $X_G + X_L + X_H = 1$  pu
- 5) Source voltage magnitudes are equal  $E_G = E_H = 1.0$  pu
- 6)  $E_H \angle 0^\circ$ , represents an infinite bus
- 7)  $E_G \angle \delta^\circ$ , with  $\delta \in (0^\circ, 180^\circ)$  swings against  $E_H$
- 8) Angle  $\delta_M$  represents angle of separation between sources G and H at which swing trajectory enters line relay characteristic.

The equations used in numerical simulations of the system represented in Figure 30 are as follows.

The current between two sources is determined by:

$$I = \frac{E_G \angle \delta - E_H \angle 0}{j(X_G + X_L + X_H)}$$

The voltage at the electrical center of the swing is:

$$V_C = E_G - j \frac{X_G + X_L + X_H}{2} I$$

The complex voltages at the line ends A and B are:

$$V_A = E_G - jX_G I$$

$$V_B = E_H + jX_H I$$

The goal of the following analysis is that depending on different system conditions in terms of strength of systems and length of the line, investigate values of different quantities of the two source system at the moment when power swing locus enters the line relay characteristic (designated with angle  $\delta_M$  in Figure 30) and test whether power swing could be identified based on voltage dip at the line terminals.

Following system conditions are investigated.

- 1) Case 1: two strong systems connected with long line (i.e.,  $X_G = X_H = 0.1$  pu and  $X_L = 0.8$  pu)
- 2) Case 2: two weak systems connected with long line ( $X_G = X_H = 0.3$  pu and  $X_L = 0.4$  pu)
- 3) Case 3: weak system G connected to strong system H with long line ( $X_G = 0.3$  pu,  $X_H = 0.1$  pu and  $X_L = 0.6$  pu)
- 4) Case 4: variation of case 3 with  $X_G = 0.4$  pu,  $X_H = 0.2$  pu and  $X_L = 0.4$  pu

Results of the analysis are summarized in Table 3 while power swing characteristics are plotted in Figures 31 and 32.

Table 3: Results										
Case	$X_G$ [pu]	$X_L$ [pu]	$X_H$ [pu]	$Zr \angle \delta$ [pu/deg]	$\delta_M$ [deg]	$V_C$ [pu]	$V_A$	$\delta_A$ [deg]	$V_B$	$\delta_B$ [deg]
1	0.1	0.8	0.1	0.639 $\angle$ 51.5	103	0.622	0.883	96.7	0.883	6.33
2	0.3	0.4	0.3	0.537 $\angle$ 68.5	137	0.366	0.522	113.9	0.522	23.06
3	0.3	0.6	0.1	0.572 $\angle$ 61	122	0.485	0.598	96.8	0.851	5.72
4	0.4	0.4	0.2	0.529 $\angle$ 71	142	0.326	0.376	101.2	0.654	10.85

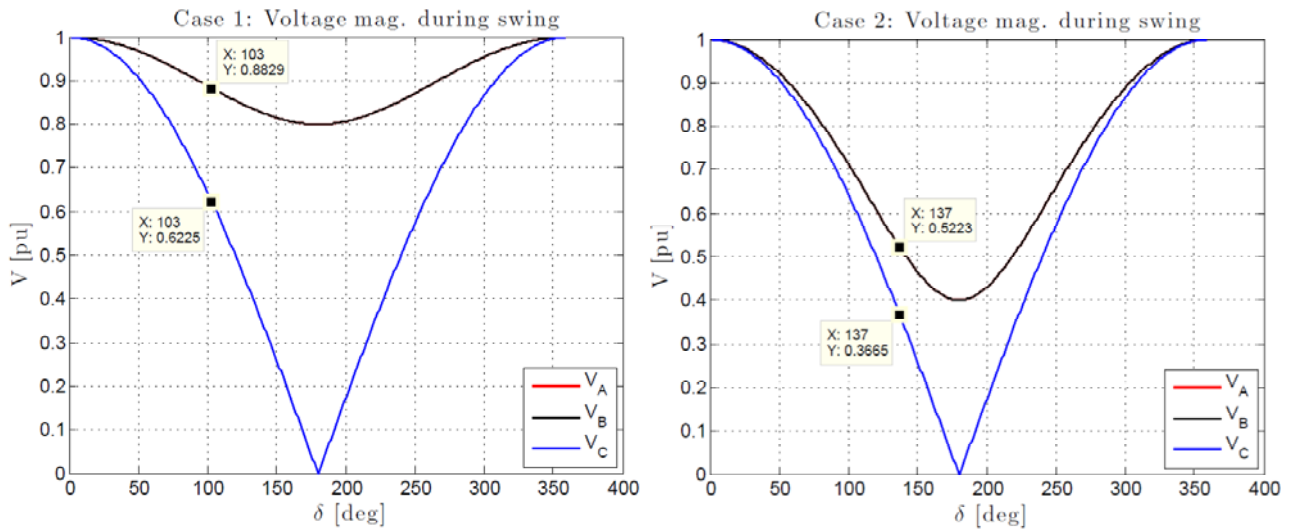


Figure 31: Case 1 and Case 2 Voltage Plots



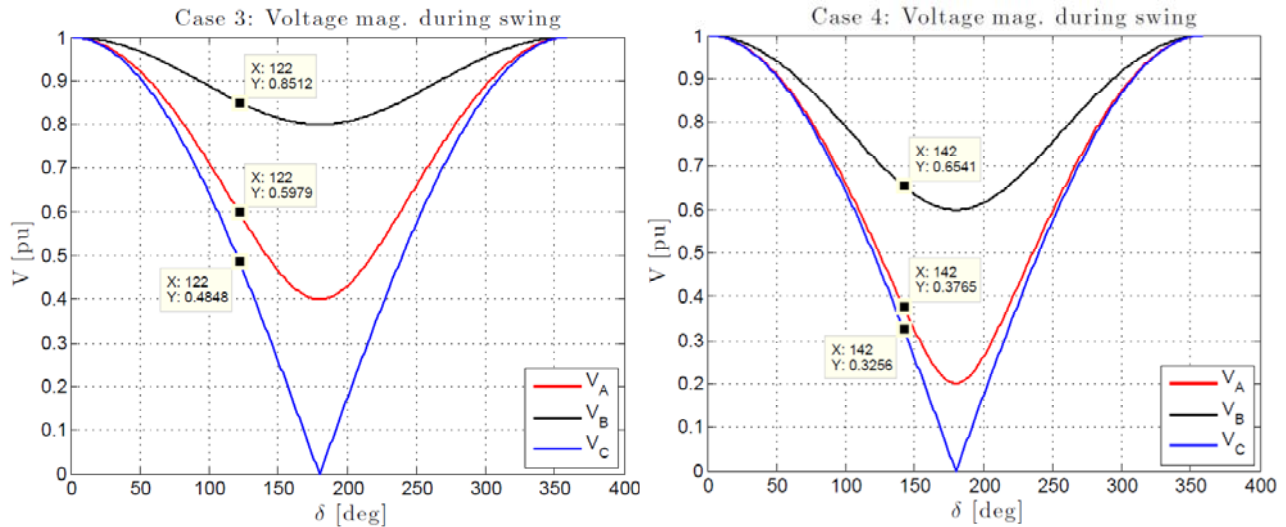


Figure 32: Case 3 and Case 4 Voltage Plots

### Discussion of the Results

Case 1: sets the minimal angle  $\delta_M$  at which power swing trajectory enters the line relay characteristic. Voltage magnitudes at line ends  $V_A$  and  $V_B$  are highest since they are electrically closer to sources than to the center of the swing. Figure 31a illustrates the voltage magnitude plot for this scenario.

Case 2: If the systems are weak (high source reactance) angle  $\delta_M$  increases and voltage magnitudes at the line end get lower (around 0.522 pu). The reason for lower line terminal voltages is its proximity to the electrical center of the swing. Fig. 30b represents voltage plot for case 2 scenario.

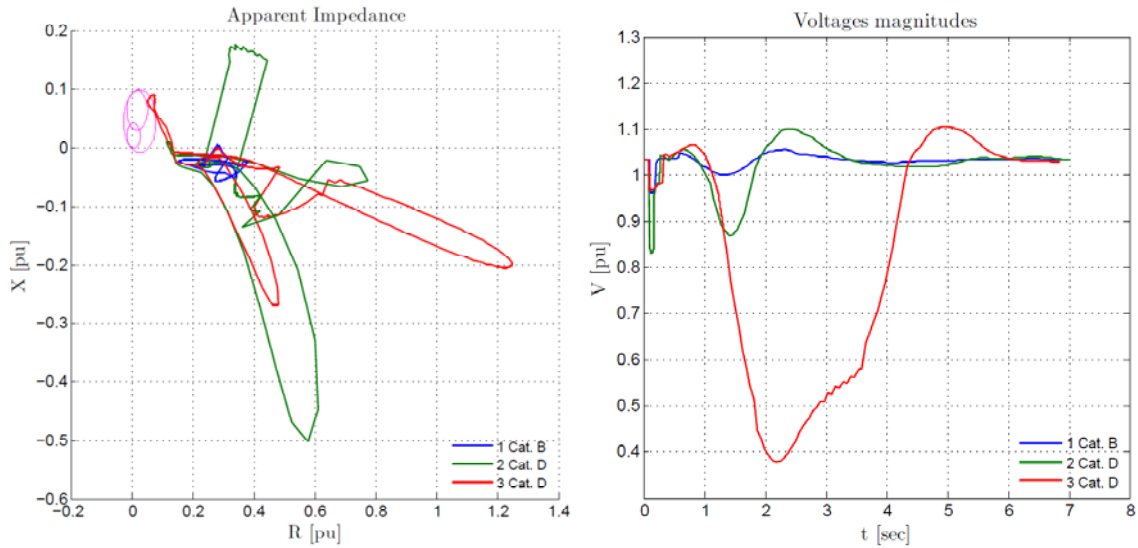
Case 3: This case represents a weak system G that swings against strong system H. Angle  $\delta_M$  is around  $120^\circ$  and the line end voltage  $V_A$  that is closer to electrical center of the swing is below 0.6 pu. Figure 32a represents voltage plot for case 3 scenario.

Case 4: This case presents variation of Case 3. The weaker is the system G (higher reactance  $X_G$ ) the higher is the angle at which power swing enters the line relay characteristic ( $\delta_M$ ) which makes it difficult to set  $120^\circ$  as a threshold for stable power swing detection. However, line terminal voltage closer to the electrical center gets very low;  $V_A = 0.376$  pu which makes it more reliable indicator for a swing. Figure 32b represents voltage plot for case 4 scenario.

The cases considered in two-source equivalent system indicate that voltage magnitude at the line terminal is a reliable indication of the power swing.

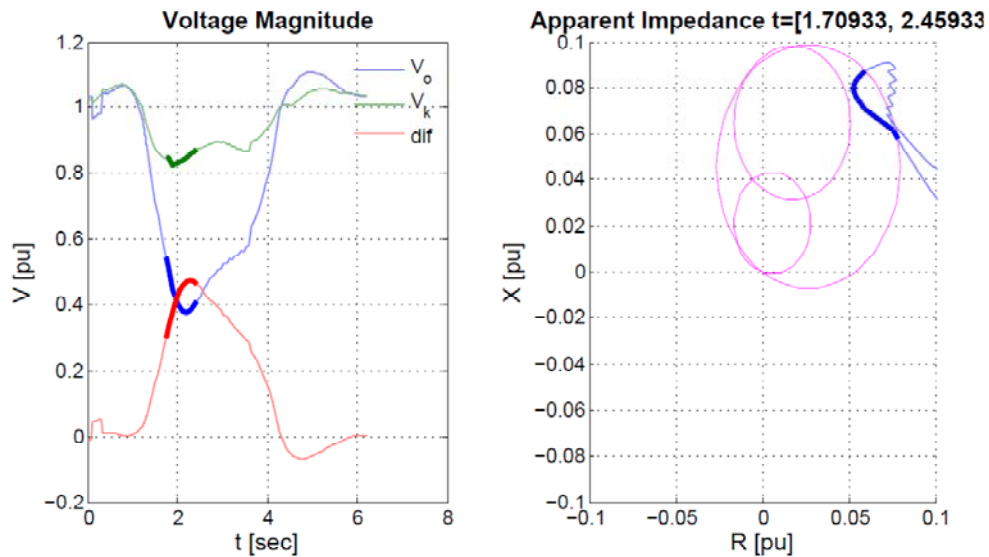
### Practical Power System Example

In order to make the proposed method practical for planning studies, and to establish potential voltage threshold for identification of stable power swings, a few transient stability simulation with a known stable power swing were performed. The first practical example is tested on New England’s bulk power system with three contingencies of increasing level of severity. Voltage at the one terminal of the line subject to power swing and apparent impedance recorded by the relay at the same line are monitored. Post disturbance apparent impedance and voltage magnitude performance for all three contingencies are presented in Figure 33.



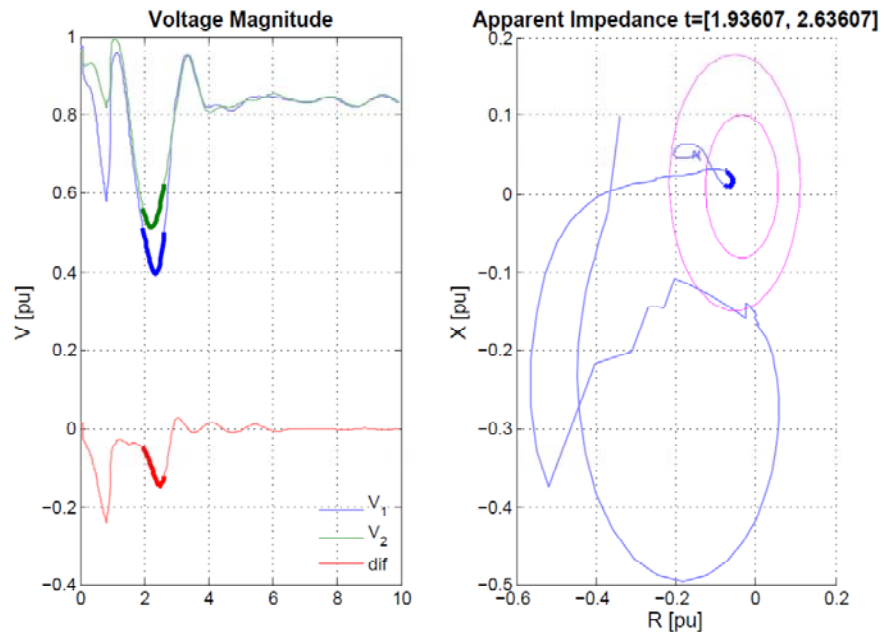
**Figure 33: Apparent Impedance and Voltage Dip Plots**

From Figure 34 one can notice a strong coupling between voltage dip and minimum apparent impedance. It is also of interest to confirm that the most severe contingency produces a stable power swing and the largest voltage dip. Since the apparent impedance plot is not time dependent, an additional analysis is performed to correlate minimum voltage dip with minimum apparent impedance during the power swing. Figure 34 presents such analysis with bold segments indicating quantities during the same time interval.



**Figure 34: Power Swing in the New England System**

The second example presented in Figure 35 is the stable power swing simulation results in the Florida system.



**Figure 35: Power Swing in the Florida System**

Analysis conducted on the New England and Florida systems suggest a few important conclusions.

- Apparent impedance and voltage magnitude are correlated, therefore for screening purposes in planning studies voltage magnitude can be used.
- Presented cases suggest that post disturbance voltage magnitude in the range of 0.5 and 0.6 pu might be used as a screening tool for power swing identification.
- Cases identified in the screening analysis require further detailed study.

Although theory and practice of the proposed voltage dip method are consistent, more test cases are needed in order to establish voltage dip threshold and applicable margin.

## Appendix E – System Protection and Control Subcommittee

---

**William J. Miller**

*Chair*  
Principal Engineer  
Exelon Corporation

**Philip B. Winston**

*Vice Chair*  
Chief Engineer, Protection and Control  
Southern Company

**Michael Putt**

*RE – FRCC*  
Manager, Protection and Control Engineering Applications  
Florida Power & Light Co.

**Mark Gutzmann**

*RE – MRO*  
Manager, System Protection Engineering  
Xcel Energy, Inc.

**Richard Quest**

*RE – MRO – Alternate*  
Principal Systems Protection Engineer  
Midwest Reliability Organization

**George Wegh**

*RE – NPCC*  
Manager – Transmission Protection and Controls Engineering  
Northeast Utilities

**Quoc Le**

*RE – NPCC -- Alternate*  
Manager, System Planning and Protection  
NPCC

**Jeff Iler**

*RE – RFC*  
Principal Engineer, Protection and Control Engineering  
American Electric Power

**Therron Wingard**

*RE – SERC*  
Principal Engineer  
Southern Company

**David Greene**

*RE – SERC -- Alternate*  
Reliability Engineer  
SERC Reliability Corporation

**Lynn Schroeder**

*RE – SPP*  
Manager, Substation Protection and Control  
Westar Energy

**Samuel Francis**

*RE – TRE*  
System Protection Specialist  
Oncor Electric Delivery

**David Penney, P.E.**

*RE – TRE – Alternate*  
Senior Reliability Engineer  
Texas Reliability Entity

**Baj Agrawal**

*RE – WECC*  
Principal Engineer  
Arizona Public Service Company

**Forrest Brock**

*Cooperative*  
Station Services Superintendent  
Western Farmers Electric Cooperative

**Miroslav Kostic**

*Federal/Provincial Utility*  
P&C Planning Manager, Transmission  
Hydro One Networks, Inc.

**Sungsoo Kim**

*Federal/Provincial Utility*  
Section Manager – Protections and Technical Compliance  
Ontario Power Generation Inc.

**Joe T. Uchiyama**

*Federal/Provincial Utility*  
Senior Electrical Engineer  
U.S. Bureau of Reclamation

**Daniel McNeely**

*Federal/Provincial Utility - Alternate*  
Engineer - System Protection and Analysis  
Tennessee Valley Authority

**Michael J. McDonald**

*Investor-Owned Utility*  
Principal Engineer, System Protection  
Ameren Services Company

**Jonathan Sykes**

*Investor-Owned Utility*  
Manager of System Protection  
Pacific Gas and Electric Company

**Charles W. Rogers**

*Transmission Dependent Utility*  
Principal Engineer  
Consumers Energy Co.

**Philip J. Tatro**

*NERC Staff Coordinator*  
Senior Performance and Analysis Engineer  
NERC

# Appendix F – System Analysis and Modeling Subcommittee

---

**John Simonelli**

*Chair*

Director - Operations Support Services  
ISO New England

**K. R Chakravarthi**

*Vice Chair*

Manager, Interconnection and Special Studies  
Southern Company Services, Inc.

**G Brantley Tillis, P.E.**

*RE – FRCC*

Manager, Transmission Planning Florida  
Progress Energy Florida

**Kiko Barredo**

*RE – FRCC – Alternate*

Manager, Bulk Transmission Planning  
Florida Power & Light Co.

**Thomas C. Mielnik**

*RE – MRO*

Manager Electric System Planning  
MidAmerican Energy Co.

**Salva R. Andiappan**

*RE – MRO – Alternate*

Manager - Modeling and Reliability Assessments  
Midwest Reliability Organization

**Donal Kidney**

*RE – NPCC*

Manager, System Compliance Program Implementation  
Northeast Power Coordinating Council

**Quoc Le**

*RE – NPCC -- Alternate*

Manager, System Planning and Protection  
NPCC

**Eric Mortenson, P.E.**

*Investor-Owned Utility*

Principal Rates & Regulatory Specialist  
Exelon Business Services Company

**Mark Byrd**

*RE – SERC*

Manager - Transmission Planning  
Progress Energy Carolinas

**Gary T Brownfield**

*RE – SERC – Alternate*

Supervising Engineer, Transmission Planning  
Ameren Services

**Jonathan E Hayes**

*RE – SPP*

Reliability Standards Development Engineer  
Southwest Power Pool, Inc.

**Kenneth A. Donohoo, P.E.**

*RE – TRE*

Director System Planning  
Oncor Electric Delivery

**Hari Singh, Ph.D.**

*RE – WECC*

Transmission Asset Management  
Xcel Energy, Inc.

**Kent Bolton**

*RE – WECC – Alternate*

Staff Engineer  
Western Electricity Coordinating Council

**Patricia E Metro**

*Cooperative*

Manager, Transmission and Reliability Standards  
National Rural Electric Cooperative Association

**Paul McCurley**

*Cooperative – Alternate*

Manager, Power Supply and Chief Engineer  
National Rural Electric Cooperative Association

**Ajay Garg**

*Federal/Provincial Utility*

Manager, Policy and Approvals  
Hydro One Networks, Inc.

**Amos Ang, P.E.**

*Investor-Owned Utility*

Engineer, Transmission Interconnection Planning  
Southern California Edison

**Bobby Jones**

*Investor-Owned Utility*

Project Manager, Stability Studies  
Southern Company Services, Inc.

**Scott M. Helyer**

*IPP*

Vice President, Transmission  
Tenaska, Inc.

**Digaunto Chatterjee**

*ISO/RTO*

Manager of Transmission Expansion Planning  
Midwest ISO, Inc.

**Bill Harm**

*ISO/RTO*

Senior Consultant  
PJM Interconnection, L.L.C.

**Steve Corey**

*ISO/RTO – Alternate*

Manager, Transmission Planning  
New York Independent System Operator

**Bob Cummings**

*NERC Staff Coordinator*

Senior Performance and Analysis Engineer  
NERC

## Appendix G – Additional Contributors

---

**John Ciuffo, P.Eng.**

Principal Engineer  
Ciuffo & Cooperberg Consulting, Inc.

**Tom Gentile**

Vice President Transmission  
Quanta Technology

**Bryan Gwyn**

Senior Director, Protection and Control Asset Management  
Quanta Technology

**Kevin W. Jones**

Principal Engineer, System Protection Engineering  
Xcel Energy

**Dmitry Kosterev**

Bonneville Power Administration

**Chuck Matthews**

Bonneville Power Administration

**John O'Connor**

Principal Engineer  
Progress Energy Carolinas

**Slobodan Pajic**

Senior Engineer, Energy Consulting  
GE Energy Management

**Fabio Rodriguez**

Principal Engineer  
Progress Energy Florida

**Tracy Rolstad**

Senior Power System Consultant  
Avista Corporation

**Joseph Seabrook**

Consulting Engineer  
Puget Sound Energy, Inc.

**Demetrios Tziouvaras**

Senior Research Engineer  
Schweitzer Engineering Laboratories, Inc.

## Standards Announcement **Reminder** Project 2010-13.3 Relay Loadability: Stable Power Swings PRC-026-1

Ballot and Non-Binding Poll Now Open through June 9, 2014

### Now Available

A ballot for **PRC-026-1 – Relay Performance During Stable Power Swings** and non-binding poll of the associated Violation Risk Factors (VRFs) and Violation Severity Levels (VSLs) is open through **8 p.m. Eastern on Monday, June 9, 2014.**

If you have questions please contact [Scott Barfield](#) via email or by telephone at (404) 446-9689.

Background information for this project can be found on the [project page](#).

### **Instructions for Balloting**

Members of the ballot pools associated with this project may log in and submit their vote for the standard and non-binding poll of the associated VRFs and VSLs by clicking [here](#).

### **Next Steps**

The ballot results will be announced and posted on the project page. The drafting team will consider all comments received during the formal comment period and, if needed, make revisions to the standard. If the comments do not show the need for significant revisions, the standard will proceed to a final ballot.

For more information on the **Standards Development Process**, please refer to the [Standard Processes Manual](#).

*For more information or assistance, please contact [Wendy Muller](#),  
Standards Development Administrator, or at 404-446-2560.*

North American Electric Reliability Corporation  
3353 Peachtree Rd, NE  
Suite 600, North Tower  
Atlanta, GA 30326  
404-446-2560 | [www.nerc.com](http://www.nerc.com)

## Standards Announcement

### Project 2010-13.3 Relay Loadability: Stable Power Swings PRC-026-1

Formal Comment Period Now Open through June 9, 2014  
Ballot Pools Forming Now through May 27, 2014

#### [Now Available](#)

A 45-day formal comment period for **PRC-026-1 – Relay Performance During Stable Power Swings** is open through **8 p.m. Eastern on Monday, June 9, 2014.**

If you have questions please contact [Scott Barfield](#) via email or by telephone at (404) 446-9689.

Background information for this project can be found on the [project page](#).

#### **Instructions for Commenting**

Please use the electronic form to [submit comments](#) on the revised definition. If you experience any difficulties in using the electronic form, please contact [Wendy Muller](#). An off-line, unofficial copy of the comment form is posted on the [project page](#).

#### **Instructions for Joining Ballot Pool**

Ballot pools are being formed for Project 2010-13.3 – Relay Loadability: Stable Power Swings and the associated non-binding poll on this project. Registered Ballot Body members must join the ballot pools to be eligible to vote in the balloting and submittal of an opinion for the non-binding poll of the associated Violation Risk Factors (VRFs) and Violation Severity Levels (VSLs). Registered Ballot Body members may join the ballot pools at the following page: [Join Ballot Pool](#)

During the pre-ballot window, members of the ballot pool may communicate with one another by using their “ballot pool list server.” (Once the balloting begins, ballot pool members are prohibited from using the ballot pool list servers.) The list servers for this project are:

**Initial Ballot:** [bp-2010-13.3\\_PRC-026-1\\_in@nerc.com](mailto:bp-2010-13.3_PRC-026-1_in@nerc.com)

**Non-Binding poll:** [bp-2010-13\\_PRC-026-1\\_NB\\_in@nerc.com](mailto:bp-2010-13_PRC-026-1_NB_in@nerc.com)

#### **Next Steps**

An initial ballot for the standard and non-binding poll of the associated VRFs and VSLs will be conducted **May 30 – June 9, 2014.**



For more information on the **Standards Development Process**, please refer to the [Standard Processes Manual](#).

*For more information or assistance, please contact [Wendy Muller](#),  
Standards Development Administrator, or at 404-446-2560.*

North American Electric Reliability Corporation  
3353 Peachtree Rd, NE  
Suite 600, North Tower  
Atlanta, GA 30326  
404-446-2560 | [www.nerc.com](http://www.nerc.com)

## Standards Announcement

### Project 2010-13.3 Relay Loadability: Stable Power Swings PRC-026-1

**Formal Comment Period Now Open through June 9, 2014**  
**Ballot Pools Forming Now through May 27, 2014**

#### [Now Available](#)

A 45-day formal comment period for **PRC-026-1 – Relay Performance During Stable Power Swings** is open through **8 p.m. Eastern on Monday, June 9, 2014.**

If you have questions please contact [Scott Barfield](#) via email or by telephone at (404) 446-9689.

Background information for this project can be found on the [project page](#).

#### **Instructions for Commenting**

Please use the electronic form to [submit comments](#) on the revised definition. If you experience any difficulties in using the electronic form, please contact [Wendy Muller](#). An off-line, unofficial copy of the comment form is posted on the [project page](#).

#### **Instructions for Joining Ballot Pool**

Ballot pools are being formed for Project 2010-13.3 – Relay Loadability: Stable Power Swings and the associated non-binding poll on this project. Registered Ballot Body members must join the ballot pools to be eligible to vote in the balloting and submittal of an opinion for the non-binding poll of the associated Violation Risk Factors (VRFs) and Violation Severity Levels (VSLs). Registered Ballot Body members may join the ballot pools at the following page: [Join Ballot Pool](#)

During the pre-ballot window, members of the ballot pool may communicate with one another by using their “ballot pool list server.” (Once the balloting begins, ballot pool members are prohibited from using the ballot pool list servers.) The list servers for this project are:

**Initial Ballot:** [bp-2010-13.3\\_PRC-026-1\\_in@nerc.com](#)

**Non-Binding poll:** [bp-2010-13\\_PRC-026-1\\_NB\\_in@nerc.com](#)

#### **Next Steps**

An initial ballot for the standard and non-binding poll of the associated VRFs and VSLs will be conducted **May 30 – June 9, 2014.**

For more information on the **Standards Development Process**, please refer to the [Standard Processes Manual](#).

*For more information or assistance, please contact [Wendy Muller](#),  
Standards Development Administrator, or at 404-446-2560.*

North American Electric Reliability Corporation  
3353 Peachtree Rd, NE  
Suite 600, North Tower  
Atlanta, GA 30326  
404-446-2560 | [www.nerc.com](http://www.nerc.com)

# Standards Announcement

## Project 2010-13.3 Phase 3 of Relay Loadability: Stable Power Swings PRC-026-1

### Ballot and Non-Binding Poll Results

#### [Now Available](#)

A ballot of **PRC-026-1 – Relay Performance During Stable Power Swings** and a non-binding poll of the associated Violation Risk Factors and Violation Severity Levels concluded at **8 p.m. Eastern on Monday, June 9, 2014**.

This standard achieved a quorum but did not receive sufficient affirmative votes for approval. Voting statistics are listed below, and the [Ballot Results](#) page provides a link to the detailed results for the ballot.

Ballot	Non-Binding Poll
Quorum / Approval	Quorum / Supportive Opinions
79.06% / 17.02%	77.71% / 17.88%

Background information for this project can be found on the [project page](#).

### Next Steps

The drafting team will consider all comments received during the formal comment period and, if needed, make revisions to the standard.

The Protection System Response to Power Swings Standard Drafting Team is meeting the week of June 16, 2014 in Denver, CO. Please see the dial-in information and links below to register for remote participation.

Click here for [Webinar access on Monday, June 16](#)

Click here for [Webinar access on Tuesday, June 17](#)

Click here for [Webinar access on Wednesday, June 18](#)

Click here for [Webinar access on Thursday, June 19](#)

Click here for [Webinar access on Friday, June 20](#)

Dial-in: 1.866.740.1260 | Participant Access Code: 1326651 | Security Code: 159357

For more information on the **Standards Development Process**, please refer to the [Standard Processes Manual](#).

*For more information or assistance, please contact [Wendy Muller](#),  
Standards Development Administrator, or at 404-446-2560.*

North American Electric Reliability Corporation  
3353 Peachtree Rd, NE  
Suite 600, North Tower  
Atlanta, GA 30326  
404-446-2560 | [www.nerc.com](http://www.nerc.com)

Log In

- Ballot Pools
- Current Ballots
- Ballot Results
- Registered Ballot Body
- Proxy Voters
- Register

[Home Page](#)

Ballot Results	
<b>Ballot Name:</b>	Project 2010-13.3 Relay Loadability Stable Power Swings PRC-026- 1
<b>Ballot Period:</b>	5/30/2014 - 6/9/2014
<b>Ballot Type:</b>	Initial
<b>Total # Votes:</b>	287
<b>Total Ballot Pool:</b>	363
<b>Quorum:</b>	<b>79.06 % The Quorum has been reached</b>
<b>Weighted Segment Vote:</b>	17.02 %
<b>Ballot Results:</b>	<b>The ballot has closed</b>

Summary of Ballot Results									
Segment	Ballot Pool	Segment Weight	Affirmative		Negative		Negative Vote without a Comment	Abstain	No Vote
			# Votes	Fraction	# Votes	Fraction			
1 - Segment 1	104	1	8	0.114	62	0.886	0	8	26
2 - Segment 2	9	0.6	0	0	6	0.6	0	2	1
3 - Segment 3	76	1	5	0.091	50	0.909	0	8	13
4 - Segment 4	26	1	4	0.211	15	0.789	0	2	5
5 - Segment 5	79	1	6	0.113	47	0.887	0	6	20
6 - Segment 6	52	1	6	0.146	35	0.854	0	4	7
7 - Segment 7	2	0.2	1	0.1	1	0.1	0	0	0
8 - Segment 8	4	0.4	0	0	4	0.4	0	0	0
9 - Segment	2	0	0	0	0	0	0	0	2

9										
10 - Segment 10	9	0.7	4	0.4	3	0.3	0	0	2	
<b>Totals</b>	<b>363</b>	<b>6.9</b>	<b>34</b>	<b>1.175</b>	<b>223</b>	<b>5.725</b>	<b>0</b>	<b>30</b>	<b>76</b>	

Individual Ballot Pool Results				
Segment	Organization	Member	Ballot	NERC Notes
1	Ameren Services	Eric Scott	Negative	SUPPORTS THIRD PARTY COMMENTS - (Ameren)
1	American Electric Power	Paul B Johnson	Negative	SUPPORTS THIRD PARTY COMMENTS - (Tom Foltz AEP)
1	American Transmission Company, LLC	Andrew Z Pusztai	Affirmative	
1	Arizona Public Service Co.	Robert Smith	Negative	COMMENT RECEIVED
1	Associated Electric Cooperative, Inc.	John Bussman	Negative	SUPPORTS THIRD PARTY COMMENTS - (AECI)
1	ATCO Electric	Glen Sutton		
1	Austin Energy	James Armke	Negative	SUPPORTS THIRD PARTY COMMENTS - (Thomas Standifur)
1	Avista Utilities	Heather Rosentrater		
1	Balancing Authority of Northern California	Kevin Smith	Negative	COMMENT RECEIVED
1	Baltimore Gas & Electric Company	Christopher J Scanlon	Negative	COMMENT RECEIVED
1	BC Hydro and Power Authority	Patricia Robertson	Abstain	
1	Black Hills Corp	Wes Wingen		
1	Brazos Electric Power Cooperative, Inc.	Tony Kroskey	Negative	SUPPORTS THIRD PARTY COMMENTS - (ACES Power Marketing)
1	Bryan Texas Utilities	John C Fontenot	Affirmative	
1	CenterPoint Energy Houston Electric, LLC	John Brockhan	Negative	SUPPORTS THIRD PARTY COMMENTS - (Oncor Electric Delivery)
1	Central Electric Power Cooperative	Michael B Bax	Negative	SUPPORTS THIRD PARTY COMMENTS - (AECI)
1	Central Iowa Power Cooperative	Kevin J Lyons	Negative	SUPPORTS THIRD PARTY COMMENTS - (CIPCO supports the comments and suggestions submitted by ACES.)
1	City of Tacoma, Department of Public Utilities, Light Division, dba Tacoma Power	Chang G Choi	Negative	SUPPORTS THIRD PARTY COMMENTS - (Chris Mattson)
1	City of Tallahassee	Daniel S Langston	Negative	SUPPORTS THIRD PARTY COMMENTS - (FMPA)
1	Clark Public Utilities	Jack Stamper		
				SUPPORTS

1	Colorado Springs Utilities	Shawna Speer	Negative	THIRD PARTY COMMENTS - (Comments - Group, Colorado Springs Utilities)
1	Consolidated Edison Co. of New York	Christopher L de Graffenried	Negative	COMMENT RECEIVED
1	CPS Energy	Glenn Pressler	Negative	COMMENT RECEIVED
1	Dairyland Power Coop.	Robert W. Roddy		
1	Deseret Power	James Tucker	Affirmative	
1	Dominion Virginia Power	Larry Nash	Negative	SUPPORTS THIRD PARTY COMMENTS - (Dominion)
1	Duke Energy Carolina	Doug E Hills	Negative	SUPPORTS THIRD PARTY COMMENTS - (Duke Energy)
1	Empire District Electric Co.	Ralph F Meyer	Affirmative	
1	Encari	Steven E Hamburg		
1	Entergy Transmission	Oliver A Burke	Negative	SUPPORTS THIRD PARTY COMMENTS - (PSEG by John Seekle)
1	FirstEnergy Corp.	William J Smith	Negative	SUPPORTS THIRD PARTY COMMENTS - (FirstEnergy Comments)
1	Florida Keys Electric Cooperative Assoc.	Dennis Minton	Negative	SUPPORTS THIRD PARTY COMMENTS - (PSEG)
1	Florida Power & Light Co.	Mike O'Neil	Affirmative	
1	Gainesville Regional Utilities	Richard Bachmeier		
1	Georgia Transmission Corporation	Jason Snodgrass	Negative	SUPPORTS THIRD PARTY COMMENTS - (ACES)
1	Great River Energy	Gordon Pietsch	Negative	SUPPORTS THIRD PARTY COMMENTS - (ACES)
1	Hydro One Networks, Inc.	Muhammed Ali	Negative	SUPPORTS THIRD PARTY COMMENTS - (NPCC RSC)
1	Hydro-Quebec TransEnergie	Martin Boisvert	Negative	SUPPORTS THIRD PARTY COMMENTS - (HQT's (provided to the DT) and NPCC's comments)
1	Idaho Power Company	Molly Devine	Negative	COMMENT RECEIVED
1	International Transmission Company Holdings Corp	Michael Moltane	Negative	COMMENT RECEIVED
1	JDRJC Associates	Jim D Cyrulewski	Abstain	
1	JEA	Ted E Hobson	Negative	SUPPORTS THIRD PARTY COMMENTS - (FMPA comments)
1	KAMO Electric Cooperative	Walter Kenyon	Negative	SUPPORTS THIRD PARTY COMMENTS - (AECI)
1	Kansas City Power & Light Co.	Daniel Gibson	Affirmative	
1	Keys Energy Services	Stanley T Rzad		
1	Lakeland Electric	Larry E Watt		



1	Lee County Electric Cooperative	John Chin	Abstain	
1	Los Angeles Department of Water & Power	faranak sarbaz	Negative	COMMENT RECEIVED
1	Lower Colorado River Authority	Martyn Turner		
1	Manitoba Hydro	Jo-Anne M Ross	Negative	COMMENT RECEIVED
1	MEAG Power	Danny Dees		
1	MidAmerican Energy Co.	Terry Harbour	Negative	COMMENT RECEIVED
1	Minnkota Power Coop. Inc.	Daniel L Inman	Abstain	
1	N.W. Electric Power Cooperative, Inc.	Mark Ramsey	Negative	SUPPORTS THIRD PARTY COMMENTS - (AECI)
1	National Grid USA	Michael Jones	Negative	SUPPORTS THIRD PARTY COMMENTS - (National Grid supports NPCC's comments.)
1	NB Power Corporation	Alan MacNaughton		
1	Nebraska Public Power District	Jamison Cawley	Negative	SUPPORTS THIRD PARTY COMMENTS - (SPP Comments)
1	New York Power Authority	Bruce Metruck	Negative	SUPPORTS THIRD PARTY COMMENTS - (NPCC and NYPA)
1	Northeast Missouri Electric Power Cooperative	Kevin White	Negative	SUPPORTS THIRD PARTY COMMENTS - (AECI)
1	Northeast Utilities	William Temple	Negative	COMMENT RECEIVED
1	Northern Indiana Public Service Co.	Julaine Dyke	Abstain	
1	NorthWestern Energy	John Canavan		
1	Ohio Valley Electric Corp.	Scott R Cunningham	Negative	SUPPORTS THIRD PARTY COMMENTS - (PSEG)
1	Oklahoma Gas and Electric Co.	Terri Pyle	Negative	SUPPORTS THIRD PARTY COMMENTS - (SPP Comments)
1	Omaha Public Power District	Doug Peterchuck	Negative	SUPPORTS THIRD PARTY COMMENTS - (MRO NSRF comments)
1	Oncor Electric Delivery	Jen Fiegel	Negative	COMMENT RECEIVED
1	Otter Tail Power Company	Daryl Hanson		
1	Pacific Gas and Electric Company	Bangalore Vijayraghavan	Abstain	
1	Peak Reliability	Jared Shakespeare	Negative	COMMENT RECEIVED
1	Platte River Power Authority	John C. Collins	Negative	SUPPORTS THIRD PARTY COMMENTS - (PSGE)
1	Portland General Electric Co.	John T Walker	Affirmative	
1	Potomac Electric Power Co.	David Thorne	Abstain	
1	PPL Electric Utilities Corp.	Brenda L Truhe	Negative	SUPPORTS THIRD PARTY COMMENTS - (Refer to comments submitted on behalf of PPL NERC Registered Affiliates.)

1	Public Service Company of New Mexico	Laurie Williams		
1	Public Service Electric and Gas Co.	Kenneth D. Brown	Negative	SUPPORTS THIRD PARTY COMMENTS - (Support Comments submitted on behalf of Public Service Enterprise Group)
1	Public Utility District No. 1 of Okanogan County	Dale Dunckel		
1	Puget Sound Energy, Inc.	Denise M Lietz	Negative	SUPPORTS THIRD PARTY COMMENTS - (Eleanor Ewry, Puget Sound Energy)
1	Rochester Gas and Electric Corp.	John C. Allen	Negative	SUPPORTS THIRD PARTY COMMENTS - (NPCC)
1	Sacramento Municipal Utility District	Tim Kelley	Negative	COMMENT RECEIVED
1	Salt River Project	Robert Kondziolka		
1	SaskPower	Wayne Guttormson		
1	Seattle City Light	Pawel Krupa	Negative	SUPPORTS THIRD PARTY COMMENTS - (Seattle City Light's Paul Haase's comment)
1	Seminole Electric Cooperative, Inc.	Glenn Spurlock		
1	Sho-Me Power Electric Cooperative	Denise Stevens	Negative	SUPPORTS THIRD PARTY COMMENTS - (AECI)
1	Snohomish County PUD No. 1	Long T Duong	Negative	SUPPORTS THIRD PARTY COMMENTS - (John Seelke, Public Service Enterprise Group)
1	South Carolina Electric & Gas Co.	Tom Hanzlik	Negative	SUPPORTS THIRD PARTY COMMENTS - (Public Service Enterprise Group (PSEG))
1	South Carolina Public Service Authority	Shawn T Abrams	Abstain	
1	Southern California Edison Company	Steven Mavis	Negative	COMMENT RECEIVED
1	Southern Company Services, Inc.	Robert A. Schaffeld	Negative	SUPPORTS THIRD PARTY COMMENTS - (Southern Company)
1	Southern Illinois Power Coop.	William Hutchison	Negative	SUPPORTS THIRD PARTY COMMENTS - (ACES)
1	Southwest Transmission Cooperative, Inc.	John Shaver	Negative	SUPPORTS THIRD PARTY COMMENTS - (ACES)
1	Sunflower Electric Power Corporation	Noman Lee Williams	Negative	SUPPORTS THIRD PARTY COMMENTS - (ACES)
1	Tampa Electric Co.	Beth Young	Negative	SUPPORTS THIRD PARTY COMMENTS - (John Seelke, PSEG)
1	Tennessee Valley Authority	Howell D Scott		

1	Trans Bay Cable LLC	Steven Powell		
1	Tri-State Generation & Transmission Association, Inc.	Tracy Sliman	Affirmative	
1	Tucson Electric Power Co.	John Tolo		
1	U.S. Bureau of Reclamation	Richard T Jackson		
1	United Illuminating Co.	Jonathan Appelbaum	Negative	SUPPORTS THIRD PARTY COMMENTS - (NPCC)
1	Vermont Electric Power Company, Inc.	Kim Moulton		
1	Westar Energy	Allen Klassen	Negative	SUPPORTS THIRD PARTY COMMENTS - (SPP Standards Group)
1	Western Area Power Administration	Lloyd A Linke		
1	Wolverine Power Supply Coop., Inc.	Michelle Clements		
1	Xcel Energy, Inc.	Gregory L Pieper	Negative	SUPPORTS THIRD PARTY COMMENTS - (Amy Casuscelli, xcel Energy)
2	BC Hydro	Venkataramakrishnan Vinnakota	Abstain	
2	California ISO	Rich Vine	Negative	COMMENT RECEIVED
2	Electric Reliability Council of Texas, Inc.	Cheryl Moseley	Negative	COMMENT RECEIVED
2	Independent Electricity System Operator	Leonard Kula	Negative	COMMENT RECEIVED
2	ISO New England, Inc.	Matthew F Goldberg	Negative	COMMENT RECEIVED
2	MISO	Marie Knox	Abstain	
2	New York Independent System Operator	Gregory Campoli	Negative	SUPPORTS THIRD PARTY COMMENTS - (NPCC RSC)
2	PJM Interconnection, L.L.C.	stephanie monzon		
2	Southwest Power Pool, Inc.	Charles H. Yeung	Negative	COMMENT RECEIVED
3	AEP	Michael E Deloach	Negative	SUPPORTS THIRD PARTY COMMENTS - (Thomas Foltz of American Electric Power)
3	Alabama Power Company	Robert S Moore	Negative	SUPPORTS THIRD PARTY COMMENTS - (Southern Company)
3	Ameren Corp.	David J Jendras	Negative	COMMENT RECEIVED
3	APS	Sarah Kist	Negative	COMMENT RECEIVED
3	Associated Electric Cooperative, Inc.	Todd Bennett	Negative	SUPPORTS THIRD PARTY COMMENTS - (Associated Electric Cooperative Inc)
3	Atlantic City Electric Company	NICOLE BUCKMAN	Abstain	
3	Avista Corp.	Scott J Kinney	Negative	SUPPORTS THIRD PARTY COMMENTS - (Heather Rosentrater)
3	BC Hydro and Power Authority	Pat G. Harrington	Abstain	
3	Central Electric Power Cooperative	Adam M Weber	Negative	SUPPORTS THIRD PARTY COMMENTS - (AECI)
				SUPPORTS

3	City of Austin dba Austin Energy	Andrew Gallo	Negative	THIRD PARTY COMMENTS - (Thomas Standifur)
3	City of Clewiston	Lynne Mila		
3	City of Farmington	Linda R Jacobson	Abstain	
3	City of Green Cove Springs	Mark Schultz	Abstain	
3	City of Redding	Bill Hughes	Negative	SUPPORTS THIRD PARTY COMMENTS - (SMUD & PSEG)
3	City of Tallahassee	Bill R Fowler	Negative	SUPPORTS THIRD PARTY COMMENTS - (FMFA)
3	Colorado Springs Utilities	Jean Mueller	Negative	SUPPORTS THIRD PARTY COMMENTS - (Group, Colorado Spring Utilities)
3	ComEd	John Bee	Negative	COMMENT RECEIVED
3	Consolidated Edison Co. of New York	Peter T Yost	Negative	COMMENT RECEIVED
3	Consumers Energy Company	Gerald G Farringer		
3	Cowlitz County PUD	Russell A Noble	Negative	COMMENT RECEIVED
3	CPS Energy	Jose Escamilla	Negative	SUPPORTS THIRD PARTY COMMENTS - (FMFA & PSEG)
3	Delmarva Power & Light Co.	Michael R. Mayer	Abstain	
3	Dominion Resources, Inc.	Connie B Lowe	Negative	SUPPORTS THIRD PARTY COMMENTS - (See Dominion's submitted comments)
3	DTE Electric	Kent Kujala	Negative	COMMENT RECEIVED
3	FirstEnergy Corp.	Cindy E Stewart	Negative	SUPPORTS THIRD PARTY COMMENTS - (FirstEnergy Comments)
3	Florida Keys Electric Cooperative	Tom B Anthony	Negative	SUPPORTS THIRD PARTY COMMENTS - (Public Service Enterprise Group)
3	Florida Municipal Power Agency	Joe McKinney	Negative	COMMENT RECEIVED
3	Florida Power & Light Co.	Summer C. Esquerre		
3	Florida Power Corporation	Lee Schuster	Negative	SUPPORTS THIRD PARTY COMMENTS - (Duke Energy)
3	Georgia System Operations Corporation	Scott McGough	Negative	SUPPORTS THIRD PARTY COMMENTS - (ACES Power Marketing)
3	Great River Energy	Brian Glover	Negative	SUPPORTS THIRD PARTY COMMENTS - (ACES)
3	Hydro One Networks, Inc.	Ayesha Sabouba	Negative	SUPPORTS THIRD PARTY COMMENTS - (NPCC-RSC)
3	JEA	Garry Baker	Negative	SUPPORTS THIRD PARTY

				COMMENTS - (FMPA)
3	Kansas City Power & Light Co.	Joshua D Bach	Affirmative	
3	Lakeland Electric	Mace D Hunter	Negative	SUPPORTS THIRD PARTY COMMENTS - (Florida Municipal Agency)
3	Lee County Electric Cooperative	David A Hadzima		
3	Lincoln Electric System	Jason Fortik	Negative	COMMENT RECEIVED
3	Los Angeles Department of Water & Power	Mike Anctil	Negative	COMMENT RECEIVED
3	Louisville Gas and Electric Co.	Charles A. Freibert	Negative	SUPPORTS THIRD PARTY COMMENTS - (comments posted by PPL NERC Registered Affiliates)
3	Manitoba Hydro	Greg C. Parent	Negative	COMMENT RECEIVED
3	MEAG Power	Roger Brand		
3	MidAmerican Energy Co.	Thomas C. Mielnik		
3	Modesto Irrigation District	Jack W Savage	Negative	SUPPORTS THIRD PARTY COMMENTS - (Public Service Enterprise Group (PSEG))
3	Muscatine Power & Water	John S Bos		
3	National Grid USA	Brian E Shanahan	Negative	SUPPORTS THIRD PARTY COMMENTS - (NPCC RSC Comments)
3	Nebraska Public Power District	Tony Eddleman	Negative	SUPPORTS THIRD PARTY COMMENTS - (I support Southwest Power Pool (SPP) comments)
3	New York Power Authority	David R Rivera		
3	Northern Indiana Public Service Co.	Ramon J Barany	Abstain	
3	NW Electric Power Cooperative, Inc.	David McDowell	Negative	SUPPORTS THIRD PARTY COMMENTS - (AECI)
3	Ocala Utility Services	Randy Hahn	Negative	SUPPORTS THIRD PARTY COMMENTS - (FMPA)
3	Oklahoma Gas and Electric Co.	Donald Hargrove	Negative	SUPPORTS THIRD PARTY COMMENTS - (SPP Comments)
3	Omaha Public Power District	Blaine R. Dinwiddie		
3	Orlando Utilities Commission	Ballard K Mutters	Negative	SUPPORTS THIRD PARTY COMMENTS - (support comments of Florida Municipal Power Agency (FMPA))
3	Owensboro Municipal Utilities	Thomas T Lyons	Affirmative	
3	Pacific Gas and Electric Company	John H Hagen	Affirmative	
3	Platte River Power Authority	Terry L Baker	Negative	SUPPORTS THIRD PARTY COMMENTS - (PSGE)

3	PNM Resources	Michael Mertz		
3	Portland General Electric Co.	Thomas G Ward		
3	Potomac Electric Power Co.	Mark Yerger	Abstain	
3	Public Service Electric and Gas Co.	Jeffrey Mueller	Negative	SUPPORTS THIRD PARTY COMMENTS - (Public Service Enterprise Group)
3	Puget Sound Energy, Inc.	Mariah R Kennedy	Negative	SUPPORTS THIRD PARTY COMMENTS - (Eleanor Ewry)
3	Sacramento Municipal Utility District	James Leigh-Kendall	Negative	COMMENT RECEIVED
3	Salt River Project	John T. Underhill	Affirmative	
3	Santee Cooper	James M Poston	Abstain	
3	Seattle City Light	Dana Wheelock	Negative	SUPPORTS THIRD PARTY COMMENTS - (Seattle City Light's Paul Haase's comment)
3	Seminole Electric Cooperative, Inc.	James R Frauen		
3	Sho-Me Power Electric Cooperative	Jeff L Neas	Negative	SUPPORTS THIRD PARTY COMMENTS - (AECI)
3	Snohomish County PUD No. 1	Mark Oens	Negative	SUPPORTS THIRD PARTY COMMENTS - (John Seelke, Public Service Enterprise Group)
3	South Carolina Electric & Gas Co.	Hubert C Young	Negative	SUPPORTS THIRD PARTY COMMENTS - (Public Service Enterprise Group (PSEG))
3	Southern California Edison Company	Lujuanna Medina	Negative	SUPPORTS THIRD PARTY COMMENTS - (SCE's comments)
3	Tacoma Power	Marc Donaldson	Negative	SUPPORTS THIRD PARTY COMMENTS - (Chris Mattson)
3	Tampa Electric Co.	Ronald L. Donahey		
3	Tennessee Valley Authority	Ian S Grant	Negative	SUPPORTS THIRD PARTY COMMENTS - (Comments by TVA)
3	Tri-State Generation & Transmission Association, Inc.	Janelle Marriott	Affirmative	
3	Westar Energy	Bo Jones	Negative	SUPPORTS THIRD PARTY COMMENTS - (SPP Standard Group)
3	Xcel Energy, Inc.	Michael Ibold	Negative	SUPPORTS THIRD PARTY COMMENTS - (Xcel Energy's)
4	Alliant Energy Corp. Services, Inc.	Kenneth Goldsmith	Negative	COMMENT RECEIVED
4	Blue Ridge Power Agency	Duane S Dahlquist	Affirmative	
4	City of Austin dba Austin Energy	Reza Ebrahimian	Negative	SUPPORTS THIRD PARTY COMMENTS - (Thomas Standifur)

4	City of Redding	Nicholas Zettel	Negative	SUPPORTS THIRD PARTY COMMENTS - (SMUD/PSEG)
4	City Utilities of Springfield, Missouri	John Allen		
4	Constellation Energy Control & Dispatch, L.L.C.	Margaret Powell	Negative	COMMENT RECEIVED
4	Consumers Energy Company	Tracy Goble		
4	Cowlitz County PUD	Rick Syring	Negative	SUPPORTS THIRD PARTY COMMENTS - (Cowlitz PUD)
4	DTE Electric	Daniel Herring	Negative	COMMENT RECEIVED
4	Florida Municipal Power Agency	Frank Gaffney	Negative	COMMENT RECEIVED
4	Georgia System Operations Corporation	Guy Andrews	Negative	SUPPORTS THIRD PARTY COMMENTS - (Aces Power Marketing)
4	Herb Schrayshuen	Herb Schrayshuen	Affirmative	
4	Illinois Municipal Electric Agency	Bob C. Thomas	Negative	SUPPORTS THIRD PARTY COMMENTS - (Florida Municipal Power Agency, and Public Service Enterprise Group)
4	Indiana Municipal Power Agency	Jack Alvey	Abstain	
4	Madison Gas and Electric Co.	Joseph DePoorter	Negative	SUPPORTS THIRD PARTY COMMENTS - (MRO NSRF)
4	Modesto Irrigation District	Spencer Tacke	Affirmative	
4	Ohio Edison Company	Douglas Hohlbaugh	Negative	SUPPORTS THIRD PARTY COMMENTS - (FirstEnergy Comments)
4	Oklahoma Municipal Power Authority	Ashley Stringer	Abstain	
4	Old Dominion Electric Coop.	Mark Ringhausen		
4	Public Utility District No. 1 of Snohomish County	John D Martinsen	Negative	SUPPORTS THIRD PARTY COMMENTS - (John Seelke, Public Service Enterprise Group)
4	Sacramento Municipal Utility District	Mike Ramirez	Negative	COMMENT RECEIVED
4	Seattle City Light	Hao Li	Negative	SUPPORTS THIRD PARTY COMMENTS - (Seattle City Light's Paul Haase's comment)
4	Seminole Electric Cooperative, Inc.	Steven R Wallace		
4	South Mississippi Electric Power Association	Steve McElhane	Affirmative	
4	Tacoma Public Utilities	Keith Morisette	Negative	SUPPORTS THIRD PARTY COMMENTS - (Chris Mattson)
4	Utility Services, Inc.	Brian Evans-Mongeon		
5	Amerenue	Sam Dwyer	Negative	SUPPORTS THIRD PARTY COMMENTS - (Ameren comments)
5	American Electric Power	Thomas Foltz	Negative	COMMENT RECEIVED
5	Arizona Public Service Co.	Scott Takinen	Affirmative	

5	Associated Electric Cooperative, Inc.	Matthew Pacobit	Negative	SUPPORTS THIRD PARTY COMMENTS - (AECI)
5	BC Hydro and Power Authority	Clement Ma	Abstain	
5	Boise-Kuna Irrigation District/dba Lucky peak power plant project	Mike D Kukla		
5	Bonneville Power Administration	Francis J. Halpin	Negative	COMMENT RECEIVED
5	Brazos Electric Power Cooperative, Inc.	Shari Heino		
5	City and County of San Francisco	Daniel Mason		
5	City of Austin dba Austin Energy	Jeanie Doty	Negative	SUPPORTS THIRD PARTY COMMENTS - (Thomas Standifur)
5	City of Redding	Paul A. Cummings	Negative	SUPPORTS THIRD PARTY COMMENTS - (SMUD & PSEG)
5	City of Tallahassee	Karen Webb	Negative	SUPPORTS THIRD PARTY COMMENTS - (FMPA)
5	City Water, Light & Power of Springfield	Steve Rose	Affirmative	
5	Cleco Power	Stephanie Huffman		
5	Cogentrix Energy Power Management, LLC	Mike D Hirst	Abstain	
5	Colorado Springs Utilities	Kaleb Brimhall	Negative	SUPPORTS THIRD PARTY COMMENTS - (Colorado Springs Utilities)
5	Con Edison Company of New York	Brian O'Boyle	Negative	COMMENT RECEIVED
5	Consumers Energy Company	David C Greyerbiehl		
5	Cowlitz County PUD	Bob Essex	Negative	SUPPORTS THIRD PARTY COMMENTS - (Cowlitz PUD)
5	Dairyland Power Coop.	Tommy Drea		
5	Dominion Resources, Inc.	Mike Garton	Negative	SUPPORTS THIRD PARTY COMMENTS - (See Dominion's submitted comments)
5	DTE Electric	Mark Stefaniak		
5	Duke Energy	Dale Q Goodwine	Negative	SUPPORTS THIRD PARTY COMMENTS - (Duke Energy)
5	Dynegy Inc.	Dan Roethemeyer	Negative	SUPPORTS THIRD PARTY COMMENTS - (PSEG)
5	E.ON Climate & Renewables North America, LLC	Dana Showalter		
5	Entergy Services, Inc.	Tracey Stubbs		
5	Exelon Nuclear	Mark F Draper	Negative	COMMENT RECEIVED
5	First Wind	John Robertson		
5	FirstEnergy Solutions	Kenneth Dresner	Negative	COMMENT RECEIVED
5	Florida Municipal Power Agency	David Schumann	Negative	COMMENT RECEIVED
5	Great River Energy	Preston L Walsh	Negative	SUPPORTS THIRD PARTY COMMENTS - (ACES)
5	Hydro-Québec Production	Roger Dufresne	Negative	SUPPORTS THIRD PARTY COMMENTS - (NPCC)



5	Ingleside Cogeneration LP	Michelle R Dantuono	Negative	COMMENT RECEIVED
5	JEA	John J Babik	Negative	SUPPORTS THIRD PARTY COMMENTS - (FMPA comments)
5	Kansas City Power & Light Co.	Brett Holland	Affirmative	
5	Kissimmee Utility Authority	Mike Blough	Negative	SUPPORTS THIRD PARTY COMMENTS - (Florida Municipal Power Agency)
5	Lakeland Electric	James M Howard		
5	Liberty Electric Power LLC	Daniel Duff	Negative	COMMENT RECEIVED
5	Lincoln Electric System	Dennis Florom	Negative	COMMENT RECEIVED
5	Los Angeles Department of Water & Power	Kenneth Silver	Negative	SUPPORTS THIRD PARTY COMMENTS - (LDWP)
5	Lower Colorado River Authority	Dixie Wells	Negative	SUPPORTS THIRD PARTY COMMENTS - (Public Service Enterprise Group (PSEG))
5	Luminant Generation Company LLC	Rick Terrill	Negative	COMMENT RECEIVED
5	Manitoba Hydro	Chris Mazur	Negative	COMMENT RECEIVED
5	Massachusetts Municipal Wholesale Electric Company	David Gordon		
5	MEAG Power	Steven Grego		
5	Muscatine Power & Water	Mike Avesing	Affirmative	
5	Nebraska Public Power District	Don Schmit	Negative	SUPPORTS THIRD PARTY COMMENTS - (SPP)
5	New York Power Authority	Wayne Sipperly	Negative	SUPPORTS THIRD PARTY COMMENTS - (NPCC and NYPA submitted comments)
5	NextEra Energy	Allen D Schriver	Negative	SUPPORTS THIRD PARTY COMMENTS - (NPCC RSC)
5	North Carolina Electric Membership Corp.	Jeffrey S Brame	Negative	SUPPORTS THIRD PARTY COMMENTS - (ACES)
5	Northern Indiana Public Service Co.	Michael D Melvin	Abstain	
5	Oglethorpe Power Corporation	Bernard Johnson	Negative	SUPPORTS THIRD PARTY COMMENTS - (ACES)
5	Oklahoma Gas and Electric Co.	Henry L Staples	Negative	SUPPORTS THIRD PARTY COMMENTS - (SPP Comments)
5	Omaha Public Power District	Mahmood Z. Safi		
5	Pacific Gas and Electric Company	Alex Chua	Abstain	
5	Platte River Power Authority	Christopher R Wood	Negative	SUPPORTS THIRD PARTY COMMENTS - (PSGE)
5	Portland General Electric Co.	Matt E. Jastram		
5	PPL Generation LLC	Annette M Bannon	Negative	SUPPORTS THIRD PARTY COMMENTS - (PPL NERC)

				Registered Affiliates)
5	PSEG Fossil LLC	Tim Kucey	Negative	SUPPORTS THIRD PARTY COMMENTS - (PSEG (Seelke))
5	Public Utility District No. 1 of Lewis County	Steven Grega		
5	Public Utility District No. 2 of Grant County, Washington	Michiko Sell		
5	Puget Sound Energy, Inc.	Lynda Kupfer	Negative	SUPPORTS THIRD PARTY COMMENTS - (Puget Sound Energy - Eleanor Ewry)
5	Sacramento Municipal Utility District	Susan Gill-Zobitz	Negative	COMMENT RECEIVED
5	Salt River Project	William Alkema	Affirmative	
5	Santee Cooper	Lewis P Pierce	Abstain	
5	Seattle City Light	Michael J. Haynes	Negative	SUPPORTS THIRD PARTY COMMENTS - (Paul Haase, Seattle)
5	Snohomish County PUD No. 1	Sam Nietfeld	Negative	SUPPORTS THIRD PARTY COMMENTS - (John Seelke, Public Service Enterprise Group)
5	South Carolina Electric & Gas Co.	Edward Magic		
5	Southern California Edison Company	Denise Yaffe	Negative	SUPPORTS THIRD PARTY COMMENTS - (Patrick Farrell)
5	Southern Company Generation	William D Shultz	Negative	SUPPORTS THIRD PARTY COMMENTS - (Southern Company)
5	Tacoma Power	Chris Mattson	Negative	COMMENT RECEIVED
5	Tampa Electric Co.	RJames Rocha		
5	Tenaska, Inc.	Scott M. Helyer		
5	Tennessee Valley Authority	David Thompson	Negative	COMMENT RECEIVED
5	Tri-State Generation & Transmission Association, Inc.	Mark Stein	Affirmative	
5	U.S. Army Corps of Engineers	Melissa Kurtz	Abstain	
5	USDI Bureau of Reclamation	Erika Doot	Negative	COMMENT RECEIVED
5	Westar Energy	Bryan Taggart	Negative	SUPPORTS THIRD PARTY COMMENTS - (SPP Standards Group comments)
5	Xcel Energy, Inc.	Mark A Castagneri	Negative	COMMENT RECEIVED
6	AEP Marketing	Edward P. Cox	Negative	SUPPORTS THIRD PARTY COMMENTS - (Tom Foltz - AEP)
6	Ameren Missouri	Robert Quinlivan	Negative	SUPPORTS THIRD PARTY COMMENTS - (Ameren)
6	APS	Randy A. Young	Negative	COMMENT RECEIVED
6	Associated Electric Cooperative, Inc.	Brian Ackermann	Negative	SUPPORTS THIRD PARTY COMMENTS -

				(AECI)
6	Bonneville Power Administration	Brenda S. Anderson	Negative	COMMENT RECEIVED
6	City of Austin dba Austin Energy	Lisa Martin	Negative	SUPPORTS THIRD PARTY COMMENTS - (Thomas Standifur)
6	City of Redding	Marvin Briggs	Negative	SUPPORTS THIRD PARTY COMMENTS - (SMUD & PSEG)
6	Cleco Power LLC	Robert Hirschak		
6	Colorado Springs Utilities	Shannon Fair	Negative	SUPPORTS THIRD PARTY COMMENTS - (Colorado Sprigs Utilities)
6	Con Edison Company of New York	David Balban	Negative	COMMENT RECEIVED
6	Constellation Energy Commodities Group	David J Carlson	Negative	COMMENT RECEIVED
6	Dominion Resources, Inc.	Louis S. Slade	Negative	SUPPORTS THIRD PARTY COMMENTS - (See Dominion's submitted comments)
6	Duke Energy	Greg Cecil	Negative	SUPPORTS THIRD PARTY COMMENTS - (Duke Energy)
6	FirstEnergy Solutions	Kevin Querry	Negative	SUPPORTS THIRD PARTY COMMENTS - (FE's Comments)
6	Florida Municipal Power Agency	Richard L. Montgomery	Negative	COMMENT RECEIVED
6	Florida Municipal Power Pool	Thomas Washburn	Negative	SUPPORTS THIRD PARTY COMMENTS - (FMPA)
6	Florida Power & Light Co.	Silvia P Mitchell	Affirmative	
6	Great River Energy	Donna Stephenson		
6	Kansas City Power & Light Co.	Jessica L Klinghoffer	Affirmative	
6	Lakeland Electric	Paul Shipps		
6	Lincoln Electric System	Eric Ruskamp	Negative	COMMENT RECEIVED
6	Lower Colorado River Authority	Michael Shaw	Negative	SUPPORTS THIRD PARTY COMMENTS - (PSEG)
6	Luminant Energy	Brenda Hampton	Negative	SUPPORTS THIRD PARTY COMMENTS - (Luminant Generation Company, LLC)
6	Manitoba Hydro	Blair Mukanik	Negative	COMMENT RECEIVED
6	Modesto Irrigation District	James McFall	Negative	SUPPORTS THIRD PARTY COMMENTS - (Public Service Enterprise Group (PSEG))
6	New York Power Authority	Shivaz Chopra	Negative	COMMENT RECEIVED
6	Northern Indiana Public Service Co.	Joseph O'Brien	Abstain	
6	Oglethorpe Power Corporation	Donna Johnson	Negative	SUPPORTS THIRD PARTY COMMENTS -

				(ACES)
6	Oklahoma Gas and Electric Co.	Jerry Nottnagel	Negative	SUPPORTS THIRD PARTY COMMENTS - (SPP Comments)
6	Omaha Public Power District	Douglas Collins	Negative	SUPPORTS THIRD PARTY COMMENTS - (MRO NSRF)
6	PacifiCorp	Sandra L Shaffer	Affirmative	
6	Platte River Power Authority	Carol Ballantine	Negative	SUPPORTS THIRD PARTY COMMENTS - (PSGE)
6	Portland General Electric Co.	Shawn P Davis		
6	Power Generation Services, Inc.	Stephen C Knapp	Affirmative	
6	Powerex Corp.	Gordon Dobson-Mack	Abstain	
6	PPL EnergyPlus LLC	Elizabeth Davis	Negative	SUPPORTS THIRD PARTY COMMENTS - (PPL NERC Registered Affiliates)
6	PSEG Energy Resources & Trade LLC	Peter Dolan	Negative	SUPPORTS THIRD PARTY COMMENTS - (Public Service Enterprise Group)
6	Public Utility District No. 1 of Chelan County	Hugh A. Owen	Abstain	
6	Sacramento Municipal Utility District	Diane Enderby	Negative	COMMENT RECEIVED
6	Salt River Project	William Abraham	Affirmative	
6	Santee Cooper	Michael Brown	Abstain	
6	Seattle City Light	Dennis Sismaet	Negative	SUPPORTS THIRD PARTY COMMENTS - (Paul Haase)
6	Seminole Electric Cooperative, Inc.	Trudy S. Novak		
6	Snohomish County PUD No. 1	Kenn Backholm	Negative	SUPPORTS THIRD PARTY COMMENTS - (John Seelke, Public Service Enterprise Group)
6	Southern California Edison Company	Joseph T Marone	Negative	SUPPORTS THIRD PARTY COMMENTS - (SCE's comments)
6	Southern Company Generation and Energy Marketing	John J. Ciza	Negative	SUPPORTS THIRD PARTY COMMENTS - (Southern Company)
6	Tacoma Public Utilities	Michael C Hill		
6	Tampa Electric Co.	Benjamin F Smith II		
6	Tennessee Valley Authority	Marjorie S. Parsons	Negative	COMMENT RECEIVED
6	Westar Energy	Grant L Wilkerson	Negative	SUPPORTS THIRD PARTY COMMENTS - (SPP Standards Group)
6	Western Area Power Administration - UGP Marketing	Peter H Kinney	Affirmative	
6	Xcel Energy, Inc.	Peter Colussy	Negative	COMMENT RECEIVED
7	Occidental Chemical	Venona Greaff	Negative	COMMENT RECEIVED
7	Siemens Energy, Inc.	Frank R. McElvain	Affirmative	
8		Roger C Zaklukiewicz	Negative	SUPPORTS THIRD PARTY

				COMMENTS - (NPCC)
8		David L Kiguel	Negative	COMMENT RECEIVED
8	Massachusetts Attorney General	Frederick R Plett	Negative	COMMENT RECEIVED
8	Volkman Consulting, Inc.	Terry Volkman	Negative	SUPPORTS THIRD PARTY COMMENTS - (Public Service Enterprise Group)
9	Commonwealth of Massachusetts Department of Public Utilities	Donald Nelson		
9	New York State Public Service Commission	Diane J Barney		
10	Florida Reliability Coordinating Council	Linda C Campbell		
10	Midwest Reliability Organization	Russel Mountjoy	Affirmative	
10	New York State Reliability Council	Alan Adamson	Negative	SUPPORTS THIRD PARTY COMMENTS - (NPCC)
10	Northeast Power Coordinating Council	Guy V. Zito	Negative	COMMENT RECEIVED
10	ReliabilityFirst	Anthony E Jablonski	Affirmative	
10	SERC Reliability Corporation	Joseph W Spencer	Affirmative	
10	Southwest Power Pool RE	Bob Reynolds	Affirmative	
10	Texas Reliability Entity, Inc.	Karin Schweitzer	Negative	COMMENT RECEIVED
10	Western Electricity Coordinating Council	Steven L. Rueckert		

[Legal and Privacy](#) : 404.446.2560 voice : 404.467.0474 fax : 3353 Peachtree Road, N.E. : Suite 600, North Tower : Atlanta, GA 30326  
 Washington Office: 1325 G Street, N.W. : Suite 600 : Washington, DC 20005-3801

[Account Log-In/Register](#)

Copyright © 2014 by the North American Electric Reliability Corporation. : All rights reserved.  
 A New Jersey Nonprofit Corporation

## Non-Binding Poll Results

### Project 2010-13.3 Phase 3 of Relay Loadability: Stable Power Swings PRC-026-1

Non-Binding Poll Results	
<b>Non-Binding Poll Name:</b>	Project 2010-13.3 Relay Loadability Stable Power Swings PRC-026-1
<b>Poll Period:</b>	5/30/2014 - 6/9/2014
<b>Total # Opinions:</b>	258
<b>Total Ballot Pool:</b>	332
<b>Ballot Results:</b>	77.71% of those who registered to participate provided an opinion or an abstention; 17.88% of those who provided an opinion indicated support for the VRFs and VSLs.

Individual Ballot Pool Results				
Segment	Organization	Member	Opinions	NERC Notes
1	Ameren Services	Eric Scott	Abstain	
1	American Electric Power	Paul B Johnson	Abstain	
1	Arizona Public Service Co.	Robert Smith	Negative	
1	Associated Electric Cooperative, Inc.	John Bussman	Negative	SUPPORTS THIRD PARTY COMMENTS - (AECI)
1	ATCO Electric	Glen Sutton		
1	Austin Energy	James Armke	Abstain	
1	Avista Utilities	Heather Rosentrater		
1	Balancing Authority of Northern California	Kevin Smith	Negative	COMMENT RECEIVED
1	BC Hydro and Power Authority	Patricia Robertson	Abstain	
1	Brazos Electric Power Cooperative, Inc.	Tony Kroskey	Negative	SUPPORTS THIRD PARTY COMMENTS - (ACES Power Marketing)
1	Bryan Texas Utilities	John C Fontenot	Affirmative	
1	CenterPoint Energy Houston Electric, LLC	John Brockhan	Abstain	
1	Central Electric Power Cooperative	Michael B Bax	Negative	SUPPORTS THIRD PARTY

				COMMENTS - (AECI)
1	Central Iowa Power Cooperative	Kevin J Lyons	Negative	SUPPORTS THIRD PARTY COMMENTS - (CIPCO supports the comments submitted for this standard submitted by ACES.)
1	City of Tacoma, Department of Public Utilities, Light Division, dba Tacoma Power	Chang G Choi	Negative	SUPPORTS THIRD PARTY COMMENTS - (Chris Mattson)
1	City of Tallahassee	Daniel S Langston	Negative	SUPPORTS THIRD PARTY COMMENTS - (FMPA)
1	Clark Public Utilities	Jack Stamper		
1	Colorado Springs Utilities	Shawna Speer	Negative	SUPPORTS THIRD PARTY COMMENTS - (Comments - Group, Colorado Springs Utilities)
1	Consolidated Edison Co. of New York	Christopher L de Graffenried	Negative	COMMENT RECEIVED
1	CPS Energy	Glenn Pressler	Negative	COMMENT RECEIVED
1	Dairyland Power Coop.	Robert W. Roddy		
1	Deseret Power	James Tucker	Abstain	
1	Dominion Virginia Power	Larry Nash	Abstain	
1	Duke Energy Carolina	Doug E Hils	Negative	SUPPORTS THIRD PARTY COMMENTS - (Duke Energy)
1	Empire District Electric Co.	Ralph F Meyer	Abstain	
1	Encari	Steven E Hamburg		
1	Entergy Transmission	Oliver A Burke	Negative	SUPPORTS THIRD PARTY COMMENTS - (PSEG by John Seelke)
1	FirstEnergy Corp.	William J Smith	Negative	SUPPORTS THIRD PARTY COMMENTS - (FirstEnergy Comments)

1	Florida Keys Electric Cooperative Assoc.	Dennis Minton	Negative	SUPPORTS THIRD PARTY COMMENTS - (PSEG)
1	Florida Power & Light Co.	Mike O'Neil	Affirmative	
1	Gainesville Regional Utilities	Richard Bachmeier		
1	Georgia Transmission Corporation	Jason Snodgrass	Negative	SUPPORTS THIRD PARTY COMMENTS - (ACES)
1	Great River Energy	Gordon Pietsch	Negative	SUPPORTS THIRD PARTY COMMENTS - (ACES)
1	Hydro One Networks, Inc.	Muhammed Ali	Negative	SUPPORTS THIRD PARTY COMMENTS - (NPCC RSC)
1	Hydro-Quebec TransEnergie	Martin Boisvert	Negative	SUPPORTS THIRD PARTY COMMENTS - (HQT's (provided to the DT) and NPCC's comments)
1	Idaho Power Company	Molly Devine	Negative	COMMENT RECEIVED
1	International Transmission Company Holdings Corp	Michael Moltane		
1	JDRJC Associates	Jim D Cyrulewski	Abstain	
1	JEA	Ted E Hobson	Negative	SUPPORTS THIRD PARTY COMMENTS - (FMPA comments)
1	KAMO Electric Cooperative	Walter Kenyon	Negative	SUPPORTS THIRD PARTY COMMENTS - (AECI)
1	Kansas City Power & Light Co.	Daniel Gibson	Affirmative	
1	Lakeland Electric	Larry E Watt		
1	Lee County Electric Cooperative	John Chin	Abstain	
1	Los Angeles Department of Water & Power	faranak sarbaz	Abstain	
1	Lower Colorado River Authority	Martyn Turner		
1	Manitoba Hydro	Jo-Anne M Ross	Negative	COMMENT RECEIVED
1	MEAG Power	Danny Dees		
1	MidAmerican Energy Co.	Terry Harbour	Negative	COMMENT RECEIVED
1	Minnkota Power Coop. Inc.	Daniel L Inman	Abstain	



1	N.W. Electric Power Cooperative, Inc.	Mark Ramsey	Negative	SUPPORTS THIRD PARTY COMMENTS - (AECI)
1	National Grid USA	Michael Jones	Negative	SUPPORTS THIRD PARTY COMMENTS - (National Grid supports NPCC's comments.)
1	NB Power Corporation	Alan MacNaughton		
1	Nebraska Public Power District	Jamison Cawley	Abstain	
1	New York Power Authority	Bruce Metruck	Negative	SUPPORTS THIRD PARTY COMMENTS - (NPCC and NYPA)
1	Northeast Missouri Electric Power Cooperative	Kevin White	Negative	SUPPORTS THIRD PARTY COMMENTS - (AECI)
1	Northeast Utilities	William Temple	Negative	
1	Northern Indiana Public Service Co.	Julaine Dyke	Abstain	
1	NorthWestern Energy	John Canavan		
1	Ohio Valley Electric Corp.	Scott R Cunningham	Abstain	
1	Oklahoma Gas and Electric Co.	Terri Pyle	Negative	SUPPORTS THIRD PARTY COMMENTS - (SPP Comment)
1	Omaha Public Power District	Doug Peterchuck	Negative	SUPPORTS THIRD PARTY COMMENTS - (MRO NSRF comments)
1	Oncor Electric Delivery	Jen Fiegel	Negative	COMMENT RECEIVED
1	Otter Tail Power Company	Daryl Hanson		
1	Pacific Gas and Electric Company	Bangalore Vijayraghavan	Abstain	
1	Peak Reliability	Jared Shakespeare	Negative	COMMENT RECEIVED
1	Platte River Power Authority	John C. Collins	Abstain	
1	Portland General Electric Co.	John T Walker	Affirmative	
1	PPL Electric Utilities Corp.	Brenda L Truhe	Negative	SUPPORTS THIRD PARTY COMMENTS - (Refer to comments submitted on behalf of PPL NERC)

				Registered Affiliates.)
1	Public Service Company of New Mexico	Laurie Williams		
1	Public Service Electric and Gas Co.	Kenneth D. Brown	Abstain	
1	Public Utility District No. 1 of Okanogan County	Dale Dunckel		
1	Puget Sound Energy, Inc.	Denise M Lietz	Negative	SUPPORTS THIRD PARTY COMMENTS - (Eleanor Ewry, Puget Sound Energy)
1	Rochester Gas and Electric Corp.	John C. Allen	Abstain	
1	Sacramento Municipal Utility District	Tim Kelley	Negative	COMMENT RECEIVED
1	Salt River Project	Robert Kondziolka		
1	SaskPower	Wayne Guttormson		
1	Seminole Electric Cooperative, Inc.	Glenn Spurlock		
1	Sho-Me Power Electric Cooperative	Denise Stevens	Negative	SUPPORTS THIRD PARTY COMMENTS - (AECI)
1	Snohomish County PUD No. 1	Long T Duong	Negative	SUPPORTS THIRD PARTY COMMENTS - (John Seelke, Public Service Enterprise Group)
1	South Carolina Electric & Gas Co.	Tom Hanzlik	Negative	SUPPORTS THIRD PARTY COMMENTS - (Public Service Enterprise Group (PSEG))
1	South Carolina Public Service Authority	Shawn T Abrams	Abstain	
1	Southern California Edison Company	Steven Mavis	Negative	COMMENT RECEIVED
1	Southern Company Services, Inc.	Robert A. Schaffeld	Negative	SUPPORTS THIRD PARTY COMMENTS - (Southern Company)
1	Southern Illinois Power Coop.	William Hutchison	Negative	SUPPORTS THIRD PARTY COMMENTS - (ACES)
1	Southwest Transmission Cooperative, Inc.	John Shaver	Negative	SUPPORTS THIRD PARTY COMMENTS - (ACES)

1	Sunflower Electric Power Corporation	Noman Lee Williams	Negative	SUPPORTS THIRD PARTY COMMENTS - (ACES)
1	Tampa Electric Co.	Beth Young	Negative	SUPPORTS THIRD PARTY COMMENTS - (John Seelke, PSEG)
1	Tennessee Valley Authority	Howell D Scott		
1	Trans Bay Cable LLC	Steven Powell		
1	Tri-State Generation & Transmission Association, Inc.	Tracy Sliman	Affirmative	
1	Tucson Electric Power Co.	John Tolo		
1	U.S. Bureau of Reclamation	Richard T Jackson		
1	United Illuminating Co.	Jonathan Appelbaum	Affirmative	
1	Vermont Electric Power Company, Inc.	Kim Moulton		
1	Westar Energy	Allen Klassen	Negative	SUPPORTS THIRD PARTY COMMENTS - (SPP Standards Group)
1	Western Area Power Administration	Lloyd A Linke		
1	Wolverine Power Supply Coop., Inc.	Michelle Clements		
2	BC Hydro	Venkataramakrishnan Vinnakota	Abstain	
2	California ISO	Rich Vine	Negative	COMMENT RECEIVED
2	Electric Reliability Council of Texas, Inc.	Cheryl Moseley	Negative	COMMENT RECEIVED
2	Independent Electricity System Operator	Leonard Kula	Affirmative	
2	ISO New England, Inc.	Matthew F Goldberg	Negative	COMMENT RECEIVED
2	MISO	Marie Knox	Abstain	
2	New York Independent System Operator	Gregory Campoli	Abstain	
2	PJM Interconnection, L.L.C.	stephanie monzon		
2	Southwest Power Pool, Inc.	Charles H. Yeung	Abstain	
3	AEP	Michael E Deloach	Abstain	
3	Alabama Power Company	Robert S Moore	Negative	SUPPORTS THIRD PARTY COMMENTS - (Southern Company)
3	Ameren Corp.	David J Jendras	Abstain	
3	APS	Sarah Kist	Negative	COMMENT RECEIVED
3	Associated Electric Cooperative, Inc.	Todd Bennett	Negative	SUPPORTS THIRD PARTY COMMENTS -

				(Associated Electric Cooperative Inc)
3	Avista Corp.	Scott J Kinney	Abstain	
3	BC Hydro and Power Authority	Pat G. Harrington	Abstain	
3	Central Electric Power Cooperative	Adam M Weber	Negative	SUPPORTS THIRD PARTY COMMENTS - (AECI)
3	City of Austin dba Austin Energy	Andrew Gallo	Abstain	
3	City of Clewiston	Lynne Mila		
3	City of Farmington	Linda R Jacobson	Abstain	
3	City of Green Cove Springs	Mark Schultz	Abstain	
3	City of Tallahassee	Bill R Fowler	Negative	SUPPORTS THIRD PARTY COMMENTS - (FMFA)
3	Colorado Springs Utilities	Jean Mueller	Negative	SUPPORTS THIRD PARTY COMMENTS - (Group, Colorado Springs Utilities)
3	Consolidated Edison Co. of New York	Peter T Yost	Negative	COMMENT RECEIVED
3	Consumers Energy Company	Gerald G Farringer		
3	Cowlitz County PUD	Russell A Noble	Negative	COMMENT RECEIVED
3	CPS Energy	Jose Escamilla	Negative	SUPPORTS THIRD PARTY COMMENTS - (FMFA & PSEG comments)
3	Dominion Resources, Inc.	Connie B Lowe	Abstain	
3	DTE Electric	Kent Kujala	Negative	COMMENT RECEIVED
3	FirstEnergy Corp.	Cindy E Stewart	Negative	SUPPORTS THIRD PARTY COMMENTS - (FirstEnergy Comments)
3	Florida Keys Electric Cooperative	Tom B Anthony	Negative	SUPPORTS THIRD PARTY COMMENTS - (Public Service Enterprise Group)
3	Florida Municipal Power Agency	Joe McKinney	Negative	COMMENT RECEIVED

3	Florida Power & Light Co.	Summer C. Esquerre		
3	Florida Power Corporation	Lee Schuster	Negative	SUPPORTS THIRD PARTY COMMENTS - (Duke Energy)
3	Georgia System Operations Corporation	Scott McGough	Negative	SUPPORTS THIRD PARTY COMMENTS - (ACES Power Marketing)
3	Great River Energy	Brian Glover	Negative	SUPPORTS THIRD PARTY COMMENTS - (ACES)
3	Hydro One Networks, Inc.	Ayesha Sabouba	Negative	SUPPORTS THIRD PARTY COMMENTS - (NPCC-RSC)
3	JEA	Garry Baker	Negative	SUPPORTS THIRD PARTY COMMENTS - (FMPA)
3	Kansas City Power & Light Co.	Joshua D Bach	Affirmative	
3	Lakeland Electric	Mace D Hunter	Negative	SUPPORTS THIRD PARTY COMMENTS - (Florida Municipal Agency)
3	Lee County Electric Cooperative	David A Hadzima		
3	Lincoln Electric System	Jason Fortik	Abstain	
3	Los Angeles Department of Water & Power	Mike Anctil	Abstain	
3	Louisville Gas and Electric Co.	Charles A. Freibert		
3	Manitoba Hydro	Greg C. Parent	Negative	COMMENT RECEIVED
3	MEAG Power	Roger Brand		
3	MidAmerican Energy Co.	Thomas C. Mielnik		
3	Modesto Irrigation District	Jack W Savage	Abstain	
3	Muscatine Power & Water	John S Bos		
3	National Grid USA	Brian E Shanahan	Negative	SUPPORTS THIRD PARTY COMMENTS - (NPCC RSC Group comments)
3	Nebraska Public Power District	Tony Eddleman	Abstain	
3	New York Power Authority	David R Rivera		
3	Northern Indiana Public Service Co.	Ramon J Barany	Abstain	
3	NW Electric Power Cooperative, Inc.	David McDowell	Negative	SUPPORTS THIRD PARTY

				COMMENTS - (AECI)
3	Ocala Utility Services	Randy Hahn	Negative	SUPPORTS THIRD PARTY COMMENTS - (FMPA)
3	Oklahoma Gas and Electric Co.	Donald Hargrove	Negative	SUPPORTS THIRD PARTY COMMENTS - (SPP Comments)
3	Omaha Public Power District	Blaine R. Dinwiddie		
3	Orlando Utilities Commission	Ballard K Mutters	Abstain	
3	Owensboro Municipal Utilities	Thomas T Lyons	Affirmative	
3	Pacific Gas and Electric Company	John H Hagen	Affirmative	
3	Platte River Power Authority	Terry L Baker	Abstain	
3	PNM Resources	Michael Mertz		
3	Portland General Electric Co.	Thomas G Ward		
3	Public Service Electric and Gas Co.	Jeffrey Mueller	Abstain	
3	Puget Sound Energy, Inc.	Mariah R Kennedy	Negative	SUPPORTS THIRD PARTY COMMENTS - (Eleanor Ewry)
3	Sacramento Municipal Utility District	James Leigh-Kendall	Negative	COMMENT RECEIVED
3	Salt River Project	John T. Underhill	Affirmative	
3	Santee Cooper	James M Poston	Abstain	
3	Seminole Electric Cooperative, Inc.	James R Frauen		
3	Sho-Me Power Electric Cooperative	Jeff L Neas	Negative	SUPPORTS THIRD PARTY COMMENTS - (AECI)
3	Snohomish County PUD No. 1	Mark Oens	Negative	SUPPORTS THIRD PARTY COMMENTS - (John Seelke, Public Service Enterprise Group)
3	South Carolina Electric & Gas Co.	Hubert C Young	Negative	SUPPORTS THIRD PARTY COMMENTS - (Public Service Enterprise Group (PSEG))
3	Southern California Edison Company	Lujuanna Medina	Negative	SUPPORTS THIRD PARTY COMMENTS - (SCE's comments)

3	Tacoma Power	Marc Donaldson	Negative	SUPPORTS THIRD PARTY COMMENTS - (Chris Mattson)
3	Tampa Electric Co.	Ronald L. Donahey		
3	Tennessee Valley Authority	Ian S Grant	Abstain	
3	Tri-State Generation & Transmission Association, Inc.	Janelle Marriott	Affirmative	
3	Westar Energy	Bo Jones	Negative	SUPPORTS THIRD PARTY COMMENTS - (SPP Standards Group)
3	Xcel Energy, Inc.	Michael Ibold	Abstain	
4	Alliant Energy Corp. Services, Inc.	Kenneth Goldsmith	Negative	COMMENT RECEIVED
4	Blue Ridge Power Agency	Duane S Dahlquist	Affirmative	
4	City of Austin dba Austin Energy	Reza Ebrahimian	Abstain	
4	City Utilities of Springfield, Missouri	John Allen		
4	Consumers Energy Company	Tracy Goble		
4	Cowlitz County PUD	Rick Syring	Negative	SUPPORTS THIRD PARTY COMMENTS - (Cowlitz PUD)
4	DTE Electric	Daniel Herring	Negative	COMMENT RECEIVED
4	Florida Municipal Power Agency	Frank Gaffney	Negative	COMMENT RECEIVED
4	Georgia System Operations Corporation	Guy Andrews	Negative	SUPPORTS THIRD PARTY COMMENTS - (ACES Power Marketing)
4	Herb Schrayshuen	Herb Schrayshuen	Affirmative	
4	Illinois Municipal Electric Agency	Bob C. Thomas	Abstain	
4	Indiana Municipal Power Agency	Jack Alvey	Abstain	
4	Madison Gas and Electric Co.	Joseph DePoorter	Abstain	
4	Modesto Irrigation District	Spencer Tacke	Affirmative	
4	Ohio Edison Company	Douglas Hohlbaugh	Negative	SUPPORTS THIRD PARTY COMMENTS - (FirstEnergy Comments)
4	Public Utility District No. 1 of Snohomish County	John D Martinsen	Negative	SUPPORTS THIRD PARTY COMMENTS - (John Seelke, Public Service Enterprise Group)

4	Sacramento Municipal Utility District	Mike Ramirez	Negative	COMMENT RECEIVED
4	Seminole Electric Cooperative, Inc.	Steven R Wallace		
4	South Mississippi Electric Power Association	Steve McElhane	Affirmative	
4	Tacoma Public Utilities	Keith Morisette	Negative	SUPPORTS THIRD PARTY COMMENTS - (Chris Mattson)
4	Utility Services, Inc.	Brian Evans-Mongeon		
5	Amerenue	Sam Dwyer	Abstain	
5	American Electric Power	Thomas Foltz	Abstain	
5	Arizona Public Service Co.	Scott Takinen	Affirmative	
5	BC Hydro and Power Authority	Clement Ma	Abstain	
5	Boise-Kuna Irrigation District/dba Lucky peak power plant project	Mike D Kukla		
5	Bonneville Power Administration	Francis J. Halpin	Negative	COMMENT RECEIVED
5	Brazos Electric Power Cooperative, Inc.	Shari Heino		
5	City and County of San Francisco	Daniel Mason		
5	City of Austin dba Austin Energy	Jeanie Doty	Abstain	
5	City of Tallahassee	Karen Webb	Negative	SUPPORTS THIRD PARTY COMMENTS - (FMFA)
5	City Water, Light & Power of Springfield	Steve Rose	Affirmative	
5	Cleco Power	Stephanie Huffman		
5	Cogentrix Energy Power Management, LLC	Mike D Hirst	Abstain	
5	Colorado Springs Utilities	Kaleb Brimhall	Negative	SUPPORTS THIRD PARTY COMMENTS - (Colorado Springs Utilities)
5	Con Edison Company of New York	Brian O'Boyle	Negative	COMMENT RECEIVED
5	Consumers Energy Company	David C Greyerbiehl		
5	Cowlitz County PUD	Bob Essex	Negative	SUPPORTS THIRD PARTY COMMENTS - (Cowlitz PUD)
5	Dairyland Power Coop.	Tommy Drea		
5	Dominion Resources, Inc.	Mike Garton	Abstain	
5	DTE Electric	Mark Stefaniak		
5	Duke Energy	Dale Q Goodwine	Negative	SUPPORTS THIRD PARTY COMMENTS - (Duke Energy)



5	Dynegy Inc.	Dan Roethemeyer	Negative	SUPPORTS THIRD PARTY COMMENTS - (PSEG)
5	E.ON Climate & Renewables North America, LLC	Dana Showalter		
5	Entergy Services, Inc.	Tracey Stubbs		
5	First Wind	John Robertson		
5	FirstEnergy Solutions	Kenneth Dresner	Negative	
5	Florida Municipal Power Agency	David Schumann	Negative	COMMENT RECEIVED
5	Great River Energy	Preston L Walsh	Negative	SUPPORTS THIRD PARTY COMMENTS - (ACES)
5	Hydro-Québec Production	Roger Dufresne	Negative	SUPPORTS THIRD PARTY COMMENTS - (NPCC)
5	Ingleside Cogeneration LP	Michelle R DAntuono	Negative	COMMENT RECEIVED
5	JEA	John J Babik	Negative	SUPPORTS THIRD PARTY COMMENTS - (FMPA comments)
5	Kansas City Power & Light Co.	Brett Holland	Affirmative	
5	Kissimmee Utility Authority	Mike Blough	Negative	SUPPORTS THIRD PARTY COMMENTS - (Florida Municipal Power Agency)
5	Liberty Electric Power LLC	Daniel Duff	Negative	COMMENT RECEIVED
5	Lincoln Electric System	Dennis Florom	Abstain	
5	Los Angeles Department of Water & Power	Kenneth Silver	Abstain	
5	Lower Colorado River Authority	Dixie Wells	Negative	SUPPORTS THIRD PARTY COMMENTS - (Public Service Enterprise Group (PSEG))
5	Luminant Generation Company LLC	Rick Terrill	Negative	COMMENT RECEIVED
5	Manitoba Hydro	Chris Mazur	Negative	COMMENT RECEIVED
5	Massachusetts Municipal Wholesale Electric Company	David Gordon		
5	MEAG Power	Steven Grego		
5	Muscatine Power & Water	Mike Avesing	Affirmative	

5	Nebraska Public Power District	Don Schmit	Abstain	
5	New York Power Authority	Wayne Sipperly	Negative	SUPPORTS THIRD PARTY COMMENTS - (NPCC and NYPA submitted comments)
5	NextEra Energy	Allen D Schriver	Negative	SUPPORTS THIRD PARTY COMMENTS - (NPCC RSC)
5	North Carolina Electric Membership Corp.	Jeffrey S Brame	Negative	SUPPORTS THIRD PARTY COMMENTS - (ACES)
5	Northern Indiana Public Service Co.	Michael D Melvin	Abstain	
5	Oglethorpe Power Corporation	Bernard Johnson	Negative	SUPPORTS THIRD PARTY COMMENTS - (ACES)
5	Oklahoma Gas and Electric Co.	Henry L Staples	Negative	SUPPORTS THIRD PARTY COMMENTS - (SPP Comments)
5	Omaha Public Power District	Mahmood Z. Safi		
5	Pacific Gas and Electric Company	Alex Chua	Abstain	
5	Platte River Power Authority	Christopher R Wood	Abstain	
5	Portland General Electric Co.	Matt E. Jastram		
5	PPL Generation LLC	Annette M Bannon	Negative	SUPPORTS THIRD PARTY COMMENTS - (PPL NERC Registered Affiliates)
5	PSEG Fossil LLC	Tim Kucey	Abstain	
5	Public Utility District No. 1 of Lewis County	Steven Grega		
5	Public Utility District No. 2 of Grant County, Washington	Michiko Sell		
5	Puget Sound Energy, Inc.	Lynda Kupfer	Negative	SUPPORTS THIRD PARTY COMMENTS - (Puget Sound Energy - Eleanor Ewry)
5	Sacramento Municipal Utility District	Susan Gill-Zobitz	Negative	COMMENT RECEIVED
5	Salt River Project	William Alkema	Affirmative	
5	Santee Cooper	Lewis P Pierce	Abstain	
5	Seattle City Light	Michael J. Haynes	Abstain	

5	Snohomish County PUD No. 1	Sam Nietfeld	Negative	SUPPORTS THIRD PARTY COMMENTS - (John Seelke, Public Service Enterprise Group)
5	South Carolina Electric & Gas Co.	Edward Magic		
5	Southern California Edison Company	Denise Yaffe	Negative	SUPPORTS THIRD PARTY COMMENTS - (Patrick Farrell)
5	Southern Company Generation	William D Shultz	Negative	SUPPORTS THIRD PARTY COMMENTS - (Southern Company)
5	Tacoma Power	Chris Mattson	Negative	COMMENT RECEIVED
5	Tampa Electric Co.	RJames Rocha		
5	Tenaska, Inc.	Scott M. Helyer		
5	Tennessee Valley Authority	David Thompson	Abstain	
5	Tri-State Generation & Transmission Association, Inc.	Mark Stein		
5	U.S. Army Corps of Engineers	Melissa Kurtz	Abstain	
5	USDI Bureau of Reclamation	Erika Doot	Negative	COMMENT RECEIVED
5	Xcel Energy, Inc.	Mark A Castagneri	Negative	COMMENT RECEIVED
6	AEP Marketing	Edward P. Cox	Abstain	
6	Ameren Missouri	Robert Quinlivan	Abstain	
6	APS	Randy A. Young	Negative	COMMENT RECEIVED
6	Associated Electric Cooperative, Inc.	Brian Ackermann	Negative	SUPPORTS THIRD PARTY COMMENTS - (AECI)
6	Bonneville Power Administration	Brenda S. Anderson	Negative	COMMENT RECEIVED
6	City of Austin dba Austin Energy	Lisa Martin	Abstain	
6	Cleco Power LLC	Robert Hirschak		
6	Colorado Springs Utilities	Shannon Fair	Negative	SUPPORTS THIRD PARTY COMMENTS - (Colorado Sprigs Utilities)
6	Con Edison Company of New York	David Balban	Negative	COMMENT RECEIVED
6	Duke Energy	Greg Cecil	Negative	SUPPORTS THIRD PARTY

				COMMENTS - (Duke Energy)
6	FirstEnergy Solutions	Kevin Query	Negative	SUPPORTS THIRD PARTY COMMENTS - (FE's Comments)
6	Florida Municipal Power Agency	Richard L. Montgomery	Negative	COMMENT RECEIVED
6	Florida Municipal Power Pool	Thomas Washburn	Negative	SUPPORTS THIRD PARTY COMMENTS - (FMPA)
6	Florida Power & Light Co.	Silvia P Mitchell	Affirmative	
6	Great River Energy	Donna Stephenson		
6	Kansas City Power & Light Co.	Jessica L Klinghoffer	Affirmative	
6	Lakeland Electric	Paul Shipps		
6	Lincoln Electric System	Eric Ruskamp	Abstain	
6	Lower Colorado River Authority	Michael Shaw	Negative	SUPPORTS THIRD PARTY COMMENTS - (PSEG)
6	Luminant Energy	Brenda Hampton	Abstain	
6	Manitoba Hydro	Blair Mukanik	Negative	COMMENT RECEIVED
6	Modesto Irrigation District	James McFall	Abstain	
6	New York Power Authority	Shivaz Chopra	Negative	COMMENT RECEIVED
6	Northern Indiana Public Service Co.	Joseph O'Brien	Abstain	
6	Oglethorpe Power Corporation	Donna Johnson	Negative	SUPPORTS THIRD PARTY COMMENTS - (ACES)
6	Oklahoma Gas and Electric Co.	Jerry Nottnagel	Negative	SUPPORTS THIRD PARTY COMMENTS - (SPP Comments)
6	Omaha Public Power District	Douglas Collins	Negative	SUPPORTS THIRD PARTY COMMENTS - (MRO NSRF)
6	PacifiCorp	Sandra L Shaffer	Abstain	
6	Platte River Power Authority	Carol Ballantine	Negative	SUPPORTS THIRD PARTY COMMENTS - (PSGE)
6	Portland General Electric Co.	Shawn P Davis		
6	Power Generation Services, Inc.	Stephen C Knapp	Affirmative	
6	Powerex Corp.	Gordon Dobson-Mack	Abstain	

6	PPL EnergyPlus LLC	Elizabeth Davis	Negative	SUPPORTS THIRD PARTY COMMENTS - (PPL NERC Registered Affiliates)
6	PSEG Energy Resources & Trade LLC	Peter Dolan	Abstain	
6	Sacramento Municipal Utility District	Diane Enderby	Negative	COMMENT RECEIVED
6	Salt River Project	William Abraham	Affirmative	
6	Santee Cooper	Michael Brown	Abstain	
6	Seattle City Light	Dennis Sismaet	Negative	SUPPORTS THIRD PARTY COMMENTS - (Paul Haase)
6	Seminole Electric Cooperative, Inc.	Trudy S. Novak		
6	Snohomish County PUD No. 1	Kenn Backholm	Negative	SUPPORTS THIRD PARTY COMMENTS - (John Seelke, Public Service Enterprise Group)
6	Southern California Edison Company	Joseph T Marone	Negative	SUPPORTS THIRD PARTY COMMENTS - (SCE's comments)
6	Southern Company Generation and Energy Marketing	John J. Ciza	Negative	SUPPORTS THIRD PARTY COMMENTS - (Southern Company)
6	Tacoma Public Utilities	Michael C Hill		
6	Tampa Electric Co.	Benjamin F Smith II		
6	Tennessee Valley Authority	Marjorie S. Parsons	Abstain	
6	Western Area Power Administration - UGP Marketing	Peter H Kinney	Affirmative	
7	Occidental Chemical	Venona Greaff	Negative	COMMENT RECEIVED
8		David L Kiguel	Negative	COMMENT RECEIVED
8		Roger C Zaklukiewicz	Negative	SUPPORTS THIRD PARTY COMMENTS - (NPCC)
8	Massachusetts Attorney General	Frederick R Plett	Affirmative	
8	Volkman Consulting, Inc.	Terry Volkman	Negative	SUPPORTS THIRD PARTY COMMENTS - (Public Service

				Enterprise Group)
9	Commonwealth of Massachusetts Department of Public Utilities	Donald Nelson		
10	Florida Reliability Coordinating Council	Linda C Campbell		
10	Midwest Reliability Organization	Russel Mountjoy	Affirmative	
10	New York State Reliability Council	Alan Adamson	Negative	SUPPORTS THIRD PARTY COMMENTS - (NPCC)
10	Northeast Power Coordinating Council	Guy V. Zito	Negative	COMMENT RECEIVED
10	ReliabilityFirst	Anthony E Jablonski	Affirmative	
10	SERC Reliability Corporation	Joseph W Spencer	Affirmative	
10	Southwest Power Pool RE	Bob Reynolds	Affirmative	
10	Texas Reliability Entity, Inc.	Karin Schweitzer	Affirmative	
10	Western Electricity Coordinating Council	Steven L. Rueckert		

- Individual or group. (70 Responses)**
- Name (46 Responses)**
- Organization (46 Responses)**
- Group Name (24 Responses)**
- Lead Contact (24 Responses)**
- Question 1 (49 Responses)**
- Question 1 Comments (56 Responses)**
- Question 2 (45 Responses)**
- Question 2 Comments (56 Responses)**
- Question 3 (47 Responses)**
- Question 3 Comments (56 Responses)**
- Question 4 (42 Responses)**
- Question 4 Comments (56 Responses)**
- Question 5 (39 Responses)**
- Question 5 Comments (56 Responses)**
- Question 6 (40 Responses)**
- Question 6 Comments (56 Responses)**
- Question 7 (39 Responses)**
- Question 7 Comments (56 Responses)**
- Question 8 (0 Responses)**
- Question 8 Comments (56 Responses)**
- Question 9 (0 Responses)**
- Question 9 Comments (56 Responses)**
- Question 10 (0 Responses)**
- Question 10 Comments (56 Responses)**

Group
Northeast Power Coordinating Council
Guy Zito
No
<p>We agree with a focused approach as outlined in the technical document. However, we have the following serious concerns with criteria in the requirements: 1. The term "credible event" should be clearly defined. The basis to determine a credible event is missing from the requirement and application guide. This basis should be provided in the standard requirement. 2. Why is the standard focused on SOL rather than IROL? The basis for specifying SOL is not supported by the example in the application guideline since the example did not show inter-area impact. 3. It is not clear in R1, criteria number 4 whether the assessment should include relay tripping or just stable power swing or both stable and unstable power swing. 4. In R2, it is unrealistic to require an entity to provide data on an Element that had tripped since 2003. There is no existing NERC continent-wide disturbance monitoring or misoperation standard that requires data be retained more than 12 months. We recommend that this requirement be removed from the standard or include only Elements that were tripped in the last calendar year. It must be noted that the standard is unsupported by the Protection System Response to Power Swings, System Protection and Control Subcommittee, August, 2013 document. Referring to p. 20, the "Need for a Standard" section, states "Based on its review of historical events, consideration of the trade-offs between dependability and security, and recognizing the indirect benefits of implementing the transmission relay loadability standard (PRC-023), the SPCS concludes that a NERC Reliability Standard to address relay performance during stable swings is not needed, and could result in unintended adverse impacts to Bulk-Power System reliability." (Emphasis added). The following report references support the PSRPS document's conclusion that this standard is not needed: 1) Page 8 of 61, 1965 Northeast Blackout Conclusion, first sentence "Relays tripping due ..." 2) Page 8 of 61, 1977 New York Blackout Conclusions, first sentence, "Relays tripping due..." 3) Page 9 of 61, July 2-3, 1996: West Coast Blackout Conclusions, first sentence "Relays tripping due.." 4) Page 10 of 61, August 10, 1996 Conclusions, first sentence, "Relays tripping due.." 5) Page 16 of 61, 2003 Northeast Blackout Conclusion, "Relays tripping due..." 6) Page 17 of 61, Overall Observations from Review of Historical Events, first and second</p>

sentences, "Relays tripping..." 7) Page 19 of 61, final paragraph, "Given the ...." NERC's informational filing in Docket No. RM08-13-000 dated July 21, 2011 concluded that there is a need for a standard on stable power swings. The subsequently developed PSRPS document, which was developed by industry experts and approved by the NERC Planning Committee, clearly refutes the FERC directive in Order No. 773 (Docket No. RM08-13-000), that was subsequently affirmed in Order Nos. 773-A and 773-B, that a standard is needed to ensure that load-responsive protective relays do not trip in response to stable power swings during non-Fault conditions. We recommend that the NERC Standards Committee explore means to utilize the more recent PSRPS document to obtain relief from the aforementioned FERC directive that is driving this project.

No

Requirement R2 requires GOs and TOs to evaluate Disturbance records "since January 1, 2003," a time that will precede the effective date of this standard. A requirement CANNOT RELY UPON RECORDS THAT PRECEDE THE EFFECTIVE DATE OF A STANDARD. As an example, PRC-005-1, which was approved in Order 693, became effective on June 11, 2007, does not require a Registered Entity to have maintenance records available for the period of time that preceded the effective date in order to calculate the next maintenance interval for a relay. We recommend that this requirement be removed from the standard or include only Elements that were tripped in the last calendar year.

No

The Purpose of the standard is "To ensure that load-responsive protective relays do not trip in response to stable power swings during non-Fault conditions." The last sentence of Background, Section 5 implies that a protective relay, while blocking for a stable power swing also allows for dependable operation for fault and unstable power swing. Requirement R3 Bullet #4 is contrary to the Purpose of the standard. The sub-Parts of R3 Bullet 4 are "or", which means that if there isn't dependable fault detection or dependable out-of-step tripping, agreement would just have to be obtained from the respective Planning Coordinator, Reliability Coordinator, and Transmission Planner of the Element that the existing Protection System design and settings are acceptable. The sub-Parts of R3 Bullet should be an "and". Item b under the fourth bullet in Requirement R3 is not stated using clear and unambiguous language whereby responsible entities, using reasonable judgment, are able to arrive at a consistent interpretation of the required performance. The R3 Rationale and the Protection System Response to Power Swings technical document provide some clarity; however, the fourth bullet is not clear and troublesome from a compliance perspective. Suggest to consider revising the fourth bullet to ensure the responsible entity understands the balance between security and dependability and how that is to be achieved by either sub-parts "a" or "b". The standard does not specify any time parameters for developing and correcting the conditions addressed by a CAP. We suggest that time parameters for developing and correcting the conditions addressed by the CAP be addressed within the requirements of the standard.

No

In the Application Guidelines, the wording under Requirement 2 for credible event is very ambiguous and needs specificity.

No.

No.

Suggest that Associated Documents (at least those where there are no copyright concerns) be included in the standard as attachments or appendices as we are concerned that cited URLs will change over time. The information in the Criteria and Criterion in the standard should not be in the requirements, but in the Rationale Boxes.

Individual

Steve Wickel

CHPD - Public Utility District No. 1 of Chelan County



<p>R1.2 - Is this an SOL for the planning (FAC-010) or operating (FAC-011) horizon? This requirement seems to be duplicating, at least in part, FAC-014 R6 (The Planning Authority shall identify the subset of multiple contingencies (if any), from Reliability Standard TPL-003 which result in stability limits.). SOLs are generally established to facilitate performance under a NERC TPL Category B performance. Select NERC TPL category C and limited D criteria are added by the WECC regional criteria. R1.3 - TPL studies require transient stability simulations, not angular stability simulations. There is no standard that requires angular stability simulations. There is no mention of angular stability simulations in FAC-010, FAC-011, or the new TPL-001-4 either. R1.4 - WECC is slowly coming on board with this as a result of the San Diego outage and is adding overcurrent relays to system models at this time. However, the relay tripping addressed in this proposed standard may also occur by distance or other elements, which are not required to be modeled in WECC at this time in its base case process. There is also a lack of a performance category for these reporting requirements (such as for Category B and C events). Performance issues may show up for extreme Category D events in the assessment, but in the language as it stands, these must also be identified and the GO and TO notified even for category D extreme events. This is a significant departure from traditional practice, which emphasizes category B and C issue communication. In the existing TPL standards, severe power swings are considered a Category D.14 event.</p>
<p>R1.1 – There should be a clarification or definition of a line-out condition. The meaning and intent of this note is not clear.</p>
<p>Individual</p>
<p>Rick Terrill</p>
<p>Luminant Generation Company LLC</p>
<p>No</p>
<p>The focused approach is too narrow for Generation Owners in that it restricts to the Transmission Planner and Generation Owner to events that have occurred and not a Planning Assessment transient stability study results that indicate load responsive relay operation is challenged. Item #4 in Requirement R1 may not capture all power system swings since it is focused on previous events. Luminant recommends that the Transmission Planner be responsible for transient stability studies and reporting the information to the Generation Owner for locations where load responsive relays are challenged. The date of 2003 needs to be removed from the standard as it prefaces compliance on data that predates the approval of the standard. Also, the Generation Owner and Transmission Owner (in cases where the Transmission Planner and Transmission Owner are not the same entity) do not have the tools to determine if the BES is configured such that a Disturbance event is still credible. Luminant believes that R2 criteria 1 and 2 need to be modified as follows: "1. An Element that load responsive relaying has tripped during the past calendar year due to a power swing during an actual system Disturbance. " "2. An Element that has formed the boundary of an island during the past calendar year during an actual system Disturbance. "</p>
<p>Yes</p>
<p>No</p>
<p>See the response to Question 1. If R2 were modified as proposed in Question 1, then Luminant would agree that these are the appropriate entities.</p>
<p>No</p>
<p>Requirement R3 focuses on a method commonly used for transmission application. Generator Owners will not be able to use this method for elements that satisfy the criteria in Requirement R1 and R2 for impedance relays used at the generator terminals or at the high voltage side of the Generator Step-up Transformer. Transmission Planners have the tools and data to perform these studies. A requirement should be added for Transmission Planners to provide the data to the Generation Owners for elements that have stable power swings that challenge the relay. Luminant recommends the following additional requirement. "Each Planning Coordinator, Reliability</p>

Coordinator, and Transmission Planner shall, within the first quarter month of each calendar year provide to the identified Generator Owner or Transmission Owner pursuant to R1, the stable power swing characteristics (i.e. R-X vs time, current vs time plots, voltage and current vs time) and identified event information." In addition, the criterion in Requirement R3 considers distance relays which is a subset of load responsive relays used in Generating Facilities. Protective relays such as loss of field, time overcurrent, and voltage controlled overcurrent relays should be excluded and listed in an Attachment similar to PRC-023.
Yes
No
The Application Guide should include examples for Generator Owners using distance relays. The example should provide illustrations of transient stability R-X plots in the time domain provided by the Transmission Planner in a format that allows the Transmission Owner and Generation Owner to plot distance relay settings.
Yes
NERC standards requirements should not reference data that predates the approval of the standard; therefore, rendering the Requirement R2 January 2003 date unenforceable.
The Attachments to the standard should include a listing of the specific load responsive relays that are included in the scope of the standard.
Individual
Michelle R. D'Antuono
Ingleside Cogeneration LP
No
Ingleside Cogeneration LP ("ICLP") believes that the drafting team has generally captured the intent of FERC Order 733 by specifying the planning and operations criteria used to identify susceptible Elements. Clearly those load responsive relays that protect Elements that have a stability constraint or are tripped in response to a stable power swing should be in scope. However, we do not agree that those Elements that form the boundary of an island during planning assessments or as a result of an actual Disturbance should be subject to PRC-026-1. Our assertion is based upon a reading of the FERC directive in Order 733, which responds to a stakeholder suggestion that islanding strategies are a reasonable approach to limit the effect of a relay that improperly reacts to a stable power swing. Instead, the project team has interpreted the ruling as a means to identify susceptible Elements – adding an unnecessary burden to every relay owner and planner in the annual assessment process. In our view, the item should be re-positioned as a bullet point in R3, which allows the TO or GO to show that an islanding scheme sufficiently protects the greater BES against instability. This would be similar to the acknowledgement that power swing blocking limits the effect of a load relay trip – essentially another mitigation strategy that may be used address a situation where the relay settings themselves cannot be changed for some reason.
Yes
Yes
No
ICLP agrees that the Transmission Owner and Generator Owner is in the best position to provide the equipment models and relay settings necessary to perform an adequate assessment. However, the application guidelines contain several statements that infer that the Transmission Planner must be involved in the process (e.g.; the TP must be consulted to validate the slip rates of power swing blocking schemes or if infeed affects the apparent impedance). In our view, there must be a mandatory means to engage the TP when such coordination is required. Otherwise, a TP could refuse to support the analysis for any reason, leaving the TO or GO to look for other less sufficient alternatives. Even if the Transmission Planner's reasons are justified, the Element owner may be found in violation of R3 due to circumstances out of their control. ICLP suggests that the same

situation was addressed in the generator validation standards – which also requires GO/TP coordination to evaluate local system performance – and could be applied in PRC-026-1.
Yes
Yes
Yes
ICLP believes that the findings by NERC’s System Protection and Control Subcommittee (SPCS) compellingly demonstrate that the initial findings from the 2003 Northeastern blackout were flawed. There is no doubt some load responsive relays did trip during the event when unusual, but non-threatening transients manifested themselves as a result of a downstream Fault. However, the SPCS found that in every case, a subsequent unstable power swing followed within seconds – and the relay would have tripped anyways. Furthermore, planning simulations confirmed that had the stable power swing in question had taken place under N-1 and N-2 contingencies – the norm to which the electric system is designed – those relays would not have reacted. Even more concerning, the report goes on to say that “over-emphasizing secure operation for stable powers swings could be detrimental to Bulk-Power System reliability” (see page 19). This means that FERC Order 733, which relies heavily on the 2003 investigative task force recommendations, may actually increase the threat of wide-area instability or Cascading. ICLP does not question FERC’s authority to order the development of a Reliability Standard – and we agree the subject matter is ultra-complex. Nevertheless, FERC should be operating to the best information available, which may have changed over time. There are far too many other pressing priorities for Registered Entities, CEAs, and even the Commission to expend this much effort on one that has little or even negative benefit. At the very least, we would like NERC or the SPCS to request a Technical Conference on the subject. Other such conferences in the past seem to have resulted in effective, yet reasonable, approaches to similarly complex issues.
Individual
Venona Greaff
Occidental Chemical Corporation
Individual
John Seelke
Public Service Enterprise Group
No
The entire standard is unsupported by the PSRPS document. See p. 20 in the “Need for a Standard” section, which states “Based on its review of historical events, consideration of the trade-offs between dependability and security, and recognizing the indirect benefits of implementing the transmission relay loadability standard (PRC-023), THE SPCS CONCLUDES THAT A NERC RELIABILITY STANDARD TO ADDRESS RELAY PERFORMANCE DURING STABLE POWER SWINGS IS NOT NEEDED, AND COULD RESULT IN UNINTENDED ADVERSE IMPACTS TO BULK-POWER SYSTEM RELIABILITY.” (Emphasis added by CAPITALIZATION.) See the specific report references below that support the PSRPS document’s conclusion that this standard is not needed: 1) Page 8 of 61, 1965 Northeast Blackout Conclusion, first sentence “Relays tripping due ...” 2) Page 8 of 61, 1977 New York Blackout Conclusions, first sentence, “Relays tripping due...” 3) Page 9 of 61, July 2-3, 1996: West Coast Blackout Conclusions, first sentence “Relays tripping due..” 4) Page 10 of 61, August 10, 1996 Conclusions, first sentence, “Relays tripping due..” 5) Page 16 of 61, 2003 Northeast Blackout Conclusion, “Relays tripping due...” 6) Page 17 of 61, Overall Observations from Review of Historical Events, first and second sentences, “Relays tripping...” 7) Page 19 of 61, final paragraph, “Given the ...” The PSRPS document, developed by industry experts and approved by the NERC Planning Committee, clearly disputes the FERC directive in Order No. 773 (Docket No. RM08-13-000), that was subsequently affirmed in Order Nos. 773-A and 773-B, that a standard is needed to ensure that load-responsive protective relays do not trip in response to stable power swings during non-Fault

conditions. NERC's informational filing in Docket No. RM08-13-000 dated July 21, 2011 concluded that there is a need for a standard on stable power swings. This conclusion is the opposite of what the PSRPS document concluded. We recommend that the NERC Standards Committee explore means to utilize the more recent PSRPS document to obtain relief from the aforementioned FERC directive that is driving this project.

No

We disagree with the need for this standard.

No

We disagree with the need for this standard. However, this requirement is so egregious with regard to one item that we offer these comments so that similar language may never appear in any future standards. R2 requires GOs and TOs to evaluate Disturbance records "since January 1, 2003," a time that will precede the effective date of this standard. A requirement cannot rely upon records that precede the effective date of a standard. As an example, PRC-005-1, which was approved in Order 693, became effective on June 11, 2007, does not require a Registered Entity to have maintenance records available for the period of time that preceded the effective date in order to calculate the next maintenance interval for a relay.

No

We disagree with the need for this standard.

No

We disagree with the need for this standard.

No

We disagree with the need for this standard.

No

We disagree with the need for this standard.

Individual

Jared Shakespeare

Peak Reliability

Yes

No

The TP's relationship to the PC is synonymous with the TOP's relationship with the RC, so leaving the TOP out as an applicable entity creates a reliability gap. The TOP is responsible for establishing SOLs.

No

Peak Reliability disagrees with the assignment of the multiple VSL's for Requirements R1, R2 and R3 because the proposed VSLs simply increase the penalty for tardiness. Any delay in identifying and element is a reliability concern. Recommend changing the VSL as follows: R1 Lower VSL: The responsible entity identified an Element and provided notification in accordance with Requirement R1, but was late by less than or equal to 7 calendar days. R1 Severe VSL: The responsible entity failed to identify an Element or to provide notification in accordance with Requirement R1 or was late by more than 7 calendar days. R2 Lower VSL: The responsible entity identified Element in accordance with Requirement R2, but was late by less than or equal to 7 calendar days. R2 Severe VSL: The responsible entity failed to identify an Element in accordance with Requirement R2 or was late by more than 7 calendar days. R3 Lower VSL: The responsible entity performed one of the options in accordance with Requirement R3, but was less than or equal to 7 calendar days late. R# Severe VSL: The responsible entity performed one of the options in accordance with Requirement





Yes
Individual
Rob Robertson
First Wind
Individual
Ronnie C. Hoeinghaus
City of Garland
Group
MRO NERC Standards Review Forum
Joe DePoorter
Yes
Yes
Yes
No
The NSRF requests that the SDT provide additional details on how the Lens characteristic is derived and examples of its use with the system parameters that were calculated from the example.
Yes
No
The NSRF believes there is some significant discussion in the guidelines and technical basis. However, we recommend that the SDT provide more clear explanation of all of the important parameters.
No
The NSRF believes there may be many elements, questions or unexpected problems in preparing for the first compliance deadline. Therefore, 24 months may be more reasonable than 12 months.
The NSRF recommends the SDT consider the following changes to add clarity to the Standard: a. Applicability (Section 4.1.1 and 4.1.4), Requirement R2 – Replace “load responsive” protective relays with “impedance based” protective relays. b. Requirement R1 – The NSRF questions the necessity of performing the identification and notification in any particular month. Why does the requirement stipulate “within the first month of each calendar year”? THE NSRF believes that it should be sufficient to use wording like, “at least once each calendar year”. c. Requirements R.1.1, R1.2 – What is meant by “stability constraints” (e.g. steady state voltage, transient voltage, steady state angle, transient angle)? The NSRF recommends that the SDT use descriptive adjectives before “stability constraint” to clarify which one, or ones, are intended. d. Requirements R1.3, R1.4 – What is meant by “Disturbances” (e.g. Category B, Category C, P1-P7)? THE NSRF recommends that the SDT use descriptive adjectives before “Disturbances” to clarify which one, or ones, are intended. e. Requirements R1.3, R2.1, R2.2 – What is meant by the term “credible” when discussing Disturbances (e.g. Disturbances associated with islands that were selected through R2 of PRC-006-1)? THE NSRF suggests developing proposed alternate language like, “relevant”, which is easier to demonstrate simply with power flow analysis, rather than valid statistical analysis. f. Requirement R1.4 – What is meant by “most recent Planning Assessment”? (e.g. TPL-002/TPL-003 annual assessment, FAC-002-1 interconnection assessment) ? THE NSRF recommends to specify which type, or types, are intended. g. Requirements R2.1, R2.2 – The NSRF questions the inclusion of the

statement "since January 1, 2003". THE NSRF believes that a specific historical time frame would be more appropriate, such as "in the past 10 years". Referring to "since January 1, 2003" makes an ever expanding historical time frame, which at some point, should no longer be relevant. h. R3 – The "Criterion" text only applies to bullet 1 and 3 only, but due to the indentation appears to be a sub element of bullet 4. Therefore, THE NSRF suggests that the "Criterion" be moved more to the left move to avoid the appearance of only applying to bullet 4. The NSRF has concerns about not having data back to 1 Jan 2003. R2 needs to have "if available prior to the effective date ". The SDT is looking for data before the effective date of the proposed Standard. We believe the intention of having the data but we did not know that the required data was needed to be saved from 1 Jan 2003. From the effective date of this Standard is another approach in retaining the required data.

Individual

Terry Harbour

MidAmerican Energy Company

No

The approach for R2 is incorrect. NERC standards cannot require compliance prior to the effective date of the standard itself. All references to 2003 should be deleted from the requirements and any guidance. Deleting the references to 2003 would make the requirement effective upon the effective date of the standard.

Yes

Yes

No

While the reliability concept of preventing unnecessary overtripping is understood, the NERC white paper supporting the PRC-026 standard indicated that tripping due to stable power swings neither contributed to blackouts or increased the severity of blackouts since 1965. The NERC standards drafting team should consider limiting the scope in R1 and R3 to out-of-step transmission related protection systems specifically designed and installed to monitor weak ties between areas or islands. These systems would open tie-lines in predetermined locations between areas in an attempt to balance load and generation between groups of generators that swing together during the identified power swings.

Yes

Yes

Yes

MidAmerican has concerns about the actual reliability benefit the proposed PRC-026 standards would provide versus the incremental compliance analysis work. There is also the potential for scope creep and the industry needs to focus on appropriate risks. The criteria specified under R1 could be broad. Criterion 4 seems susceptible to significant scope creep stating, "An Element identified in the more recent Planning Assessment where relay tripping occurred for a power swing during a disturbance." Planning Assessments are performed regularly in the TPL standards. The new TPL-001-4 planning standard and R3.1.1 requires the simulated "removal of all elements that the Protection System and other automatic controls are expected to disconnect for each Contingency without operator intervention". At a minimum, this will require generic protection models for each BES line, generator, and transformer. If the Planning assessment shows a protection model trip, will that element require a PRC-026 analysis? Many entities are performing stability studies for existing TOP standards on a short-term to nearly daily basis to verify that entities are not entering and "unknown state". While such studies aren't a traditional "Planning Assessments", could short-term TOP related dynamic analyses that show potential tripping (such as exceeding a protection setting limit) be forced to prove tripping wasn't due to stable power swings in PRC-026? Will the criteria in R1



inappropriately identify suggested islands required by PRC-006? The NERC PRC-006 UFLS standards require entities to identify and simulate islands. Will PRC-026 inappropriately identify PRC-006 islands (which may not have a real UFLS event as a basis) because PRC-006 required an island be developed and a simulation be performed by a powerflow stability simulation which considers angular stability? Criterion 3 mentions both island boundaries and angular stability. There is a qualifier of a credible event. But entities will construct reasonable events for PRC-006. Are reasonable and credible the same?

Individual

Kayleigh Wilkerson

Lincoln Electric System

Although appreciative of the drafting team's efforts in developing PRC-026-1, LES questions whether the development of a Reliability Standard is necessary for addressing relay performance during stable power swings. Further consideration should instead be given to the recommendations of the System Protection and Control Subcommittee which noted that "a NERC Reliability Standard to address relay performance during stable power swings is not needed, and could result in unintended adverse impacts to Bulk Power System reliability". In lieu of the standards development process, LES suggests communicating to FERC an alternative to a Reliability Standard such as an industry guidance or reference document.

Group

Seattle City Light

Paul Haase

The Standard is very complicated and confusing. It appears to be a lot like FERC Order 754 effort that we recently went through, which required two or three rounds of submissions before industry was providing the information envisioned by the framers of the process. Proposed PRC-026 involves considerable new interaction between the Planning and Protection groups. The Application Guidelines, while somewhat helpful, need to include much more explicit examples. A flow chart, or something similar, is necessary to fully delineate the steps in the process. Much more guidance is definitely needed before the Standard can be implemented. This draft of the Standard represents a work in progress, at best. Before any such untried process be mandated as a Standard (if it is ultimately deemed necessary that a Standard is required) Seattle City Light recommends a non-mandatory trial period of at least two years, long enough to work the bugs out of the system and ensure that entities understand and are able to perform the activities as envisioned and required. Perhaps such a trail could be conducted as a NERC request for data under Section 1600 Rules of Procedure.

Individual
Thomas Foltz
American Electric Power
Yes
We agree with the focused approach. We would recommend qualifying the term “stability,” in R1.2 in particular, as “transient or oscillatory stability” so that voltage or steady-state stability, which would not cause power swings, are not mistakenly construed by an auditor. TPL-001-4 permits use of generic relay models in dynamic simulation planning studies, so the reference in R1.4 to relay tripping in planning assessments may not end up being based on the relays actually installed.
No
Generator Owners may not have the information or expertise needed to determine if their Element formed the boundary of an island (R2 Criteria 2) or if the Disturbance that caused a trip or islanding condition remains to be credible. It is unclear how the operation of Automatic Load Rejection (ALR) on a power generation unit during a system event affects applicability to R2 of the standard. The proper operation of a unit’s ALR controls should not result in its automatic inclusion. Clarity is needed in this standard so that only those relays that operated for the observed or simulated power swings in R1 or R2 are applicable to R3.
No
In reference to R3, bullet point four, sub items a and b, we do not believe it is necessary to obtain further agreement with the PC, RC and TP, as there is no benefit to reliability (since it was not possible to achieve dependability) and represents an unnecessary administrative burden. Rather, the TO should be required only to *notify* the PC, RC, and TP. The bullet points of R3 should be revised to replace “Demonstrate that the existing protection system is not expected to trip...” with “Demonstrate that the existing Protection System satisfies the criteria...”. This would prevent the GO or TO from being found non-compliant if they were to set the relaying in accordance with the criterion, but unforeseen events caused a relay to operate. We agree with the approach, but do not believe that R3 would need to be executed annually. It should only need to be done once per relay until something about the relay in question or the transmission system in the immediate vicinity changes.
No
The severe VSL for R1 and R2 could be interpreted that a lack of applicable elements would be a violation. It should be revised so that it is clear that the entity owns an element that should have been identified, but did not identify that element.
No
The Application Guidelines and Technical Basis section makes a number of assumptions and expectations, which would be difficult to prove. For example, “If PSB is applied, it is expected that the relays were set in consultation with the Transmission Planner to verify maximum slip rates.” Does such a quote imply an obligation to prove such consultation took place? This section should not imply or specify any obligations not contained elsewhere in the requirements.
No
The implementation plan only allows the GO/TO 11 months to complete their initial R3 study of all Elements identified in R1. We believe the time allowed is too short for the initial implementation of the standard, as the GO/TO will need to research all Elements, not just those incrementally added from the previous year’s planning analysis. The implementation plan should be revised to guarantee the GO/TO a minimum of at least 36 months to complete their initial R2 and R3 studies. The timing of the sequence as proposed in the standard is acceptable after the initial implementation. However, as currently written, the initial implementation plan does not guarantee adequate time for the applicable Entities to become compliant.
AEP supports the proposed standard’s scope and overall direction, but has chosen to vote negative based on the various concerns expressed in our response. AEP envisions voting in the affirmative once sufficient concerns have been addressed in future drafts. R2 should be revised to be forward-

looking only. Generator Owners and Transmission Owners were not required in the past to keep comprehensive records of these events and cannot be expected to know all applicable Elements as implied by the standard. If after the initial standard implementation period, an Entity identifies an applicable Element based on a Disturbance occurring between 1/1/2003 and the standard effective date, the Entity could be found non-compliant with R2 and R3. If the drafting team feels it is absolutely necessary to go back to 2003, the standard should be revised to allow an Entity to remain fully compliant with R2 and R3 at any time an Element is identified based on a Disturbance occurring between 1/1/2003 and the effective date of the standard. This could be accomplished by adding wording to bring newly identified Elements into scope of R2 and R3 during the first full calendar year after they are identified. The R2 criterion assumes that registered entities have had a process in place to flag events due to power swings and retain information related to them. We do not believe that industry should be required to identify and provide information on events that have occurred in the past. There has been no established standard requirement to capture this information, so there is no way to reliably conclude that all events caused by power swings have been identified. In the event such historical information \*is\* required, the standard should explicitly state that such information is needed only once rather than once every calendar year. The standard should require the Transmission Owner to make the system impedance available to the Generator Owner annually or within 30 days of a written request. The Generator Owner would not normally have this information, but will need it in order to meet their obligations under R3. It is not clear why R3 will require the TO/GO's Elements to be studied annually. A study's result should remain valid until either the relay setting changes or the impedance changes significantly. The standard should be revised to only require a study be repeated if the relay setting is changed or if the generator, GSU or system impedances change by 10% or more. The standard should not require the study of voltage controlled/restrained overcurrent relays or loss of field relays. In stable power swings, the voltage should remain above the threshold that allows these voltage controlled/restrained overcurrent relays to operate. Failure to set the relay appropriately should be reported and corrected under the requirements of PRC-004. Loss of field relays are installed as part of the generator protection and should be permitted to trip when necessary to protect the generator, regardless of whether the power swing is stable or unstable.

Individual

Chris de Graffenried

Consolidated Edison, Inc.

No

We agree with a focused approach as outlined in the technical document. However, we have the following serious concerns with criteria in the requirements: 1. The term "credible event" should be clearly defined. The basis to determine a credible event is missing from the requirement and application guide. This basis should be provided in the standard requirement. 2. Why is the standard focused on SOL rather than IROL? The basis for specifying SOL is not supported by the example in the application guideline since the example did not show inter-area impact. 3. It is not clear in R1, criteria number 4 whether the assessment should include relay tripping or just stable power swing or both stable and unstable power swing. 4. In R2, it is unrealistic to require an entity to provide data on an Element that had tripped since 2003. There is no existing NERC continent-wide disturbance monitoring or misoperation standard that requires data be retained more than 12 months. We recommend that this requirement be removed from the standard or include only Elements that were tripped in the last calendar year.

Yes

Yes

See comment #4 under Question #1. In R2, it is unrealistic to require an entity to provide data on an Element that had tripped since 2003. There is no existing NERC continent-wide disturbance monitoring or misoperation standard that requires data be retained more than 12 months. We recommend that this requirement be removed from the standard or include only Elements that were tripped in the last calendar year.

No

The purpose of the standard is "to ensure that load responsive relay do not trip in response to stable power swing during non-fault condition." The last sentence of Background, Section 5 implies that

protective relay while blocking for a stable power swing also allows for dependable operation for fault and unstable power swing. Bullet #4 in R3 indicates that the GO and TO must obtain agreement if dependable protection or dependable out-of-step tripping is not provided by a protection system that is immune to a stable power swing. Bullet #4 seems to imply that the purpose of the standard is to ensure blocking for a stable power swing and dependable tripping for unstable power swing. The drafting team needs to be very clear in the standard what the intention is. For instance, a line current differential scheme is immune to stable and unstable power swing and will provide dependable tripping for fault. The criteria as written implies that this type of scheme will need to be modified or an agreement will need to be obtained from the PC, RC and TP to deploy since it does not provide dependable out-of-step tripping.

Yes

No

1. In the Application Guidelines, the wording under Requirement 2 for "credible event" is very open-ended. 2. An example of how line differential protection would be treated with respect to Requirement 3 would be helpful. See the comment above in Question 4.

Yes

No

No

Individual

Cheryl Moseley

Electric Reliability Council of Texas, Inc.

No

The time periods in the requirements are unnecessarily restrictive, particularly R1, which essentially requires the work to be done in January of each year. There does not appear to be a reliability reason to have the work completed in January as long as the GO and TO perform the necessary actions in R3 in a timely manner. We suggest taking an approach similar to PRC-023 R6. In this case R1 would begin: "Each Planning Coordinator, Reliability Coordinator, and Transmission Planner shall conduct an assessment at least once each calendar year, with no more than 15 months between assessments..." R2 through R4 could use a similar approach. The identification of Elements in R1 seems to be unnecessarily redundant between the applicable entities for some criteria and inappropriate for other criteria. ERCOT suggests splitting R1 into two separate requirements based on the responsible entity: one requirement for the Planning Coordinator to identify elements per criteria 2, 3, and 4; and one requirement for the Reliability Coordinator to identify elements per criterion 1. The Transmission Planner should be removed from the Applicability of the standard, including removal from R3.

No

See our comments to Q1.

Yes

ERCOT agrees with the NERC System Protection and Control Subcommittee August 2013 report titled Protection System Response to Power Swings which states: "Based on its review of historical events, consideration of the trade-offs between dependability and security, and recognizing the indirect benefits of implementing the transmission relay loadability standard (PRC-023), the SPCS concludes that a NERC Reliability Standard to address relay performance during stable power swings

is not needed, and could result in unintended adverse impacts to Bulk-Power System reliability.” Accordingly, ERCOT recommends that the standard not move forward. If the standard does move forward ERCOT recommends that requirements R1, R2, and R3 be changed from an annual requirement to once every 60 months in order to minimize unintended adverse impacts to Bulk-Power System reliability.

Individual

Amy Casuscelli

Xcel Energy

Individual

Andrew Z. Pusttai

American Transmission Company, LLC

Yes

Yes

Yes

No

ATC requests that the SDT provide additional details on how the Lens characteristic is derived and examples of its use with the system parameters that were calculated from the example.

Yes

No

ATC believes there is some significant discussion in the guidelines and technical basis, however, recommends that the SDT provide more clear explanation of all of the important parameters.

No

ATC believes there may be many elements, questions or unexpected problems in preparing for the first compliance deadline. Therefore, 24 months may be more reasonable than 12 months.

ATC recommends the SDT consider the following changes to add clarity to the Standard: a. Applicability (Section 4.1.1 & 4.1.4), Requirement R2 – Replace “load responsive” protective relays with “impedance based” protective relays. b. Requirement R1 – ATC questions the necessity of performing the identification and notification in any particular month. Why does the requirement stipulate “within the first month of each calendar year”? ATC believes that it should be sufficient to use wording like, “at least once each calendar year”. c. Requirements R.1.1, R1.2 – What is meant by “stability constraints” (e.g. steady state voltage, transient voltage, steady state angle, transient angle)? ATC recommends that the SDT use descriptive adjectives before “stability constraint” to clarify which one, or ones, are intended. d. Requirements R1.3, R1.4 – What is meant by “Disturbances” (e.g. Category B, Category C, P1-P7)? ATC recommends that the SDT use descriptive adjectives before “Disturbances” to clarify which one, or ones, are intended. e. Requirements R1.3, R2.1, R2.2 – What is meant by the term “credible” when discussing Disturbances (e.g. Disturbances associated with islands that were selected through R2 of PRC-006-1)? ATC suggests developing proposed alternate language like, “relevant”, which is easier to demonstrate simply with power flow analysis, rather than valid statistical analysis. f. Requirement R1.4 – What is meant by “most recent Planning Assessment”? (e.g. TPL-002/TPL-003 annual assessment, FAC-002-1 interconnection assessment) ? ATC recommends to specify which type, or types, are intended. g. Requirement R2, Criteria 1 and 2 – ATC has concerns about requiring entities to refer to data on power swings and forming an island back to 1 Jan 2003. ATC recommends additional text in the Criteria such as “if available prior to the effective date ” immediately after “since January 1, 2003”. Retaining this data prior 1 Jan 2003 was not required as implied by the proposed Standard. Another approach for SDT consideration would be to require retention of data from the effective date of the Standard. h. Requirements R2.1, R2.2 – ATC questions the inclusion of the statement “since January 1, 2003”.

ATC believes that a specific historical time frame would be more appropriate, such as "in the past 10 years". Referring to "since January 1, 2003" makes an ever expanding historical time frame, which at some point, should no longer be relevant. i. R3 – The "Criterion" text only applies to bullet 1 and 3 only, but due to the indentation appears to be a sub element of bullet 4. Therefore, ATC suggests that the "Criterion" be moved more to the left move to avoid the appearance of only applying to bullet 4.

Individual

Jo-Anne

Ross

Yes

Yes

Yes

Yes

Yes

Yes

Yes

1) In R1, please clarify what you mean by "Stability constrained", does it mean the constraint for angular stability only or does it include other stability concerns such as transient voltage violations? 2) Also in R1, does "Line-out conditions" mean "N-1" condition? 3) What definition of an island is used in the standard? 4) In R1 through R4, why is long-term planning included in the time horizon? The standard is not clear that an assessment of the 10-year planning horizon is expected. It seems the assessment is more based on the current system or at most plans proposed to be implemented in the next year, which makes this applicable to Operations Planning only. The Table of compliance elements discussing notification deadlines of 30-90 days is more applicable to an Operations Planning time horizon. If we see an issue in 2020, due to a new proposed Facility, why do we have to notify anyone within 30 days today in order to be compliant with the standard? We have time to investigate alternatives, new settings etc. If the problem still exists in the operations horizon, this standard is applicable.

Individual

Mark Wilson

Independent Electricity System Operator

No

The criteria used to limit the applicability of the transmission lines are unclear. Specifically, • Regarding Criteria 1 in Requirement 1, entities' may employ SPS to avoid tripping of any Element for stable power swings under all normal recognized contingencies included in the TPL standards. Given that the SPS is used as a mitigation measure, should this proposed standard be applicable to those elements that are susceptible to trip for stable power swings, when a failure of the SPS is considered? • Similar to the above, for Criteria 2 in Requirement 1, entities' may establish an SOL to avoid tripping of any Element for stable power swings under all normal recognized contingencies included in TPL standards. Given that SOL is used as a mitigation measure, should those elements susceptible to trip for stable power swings, when the SOL is exceeded (and which is not allowed in normal operation conditions) be applicable to this proposed standard? • Requirement 1 stipulates that the responsible entity notify the facility owner of an Element that meets Criteria 2 (i.e., an Element associated with a System Operating Limit (SOL) that has been established based on

stability constraints). It is not clear whether the Element is the contingent Element or the monitored Element or both. This needs to be clarified/specified in the standard/requirement. • Requirement 1 stipulates that the responsible entity notify the facility owner of an Element that meets Criteria 3 (i.e., has formed the boundary of an island within an angular stability planning simulation where the system Disturbance(s) that caused the islanding condition continues to be a credible event. The term "credible event" is hard to determine since the Disturbance could be caused by one of those events listed in the TPL standards, or could be one that is beyond those listed, such as natural phenomena. • We realize that the Application Guideline provides some general guidance on assessing the creditability of a Disturbance, but we do not agree that a Disturbance is no longer credible when it is deemed no longer capable of occurring in the future due to actual changes to the BES. Changes to the BES may reduce the possibility of the same Disturbance, but such Disturbances (e.g. loss of right of way or an entire station) may still occur due to other means. If the SDT should continue to hold the position that the criteria for excluding a Disturbance is that BES changes are made to mitigate (but not totally eliminate) the recurrence, then it should be clearly stated in the requirement itself. • In short, the basis with which to deem a Disturbance "credible" is missing from the requirements, which needs to be provided/clarified in the standard/requiremen

Yes

Yes

We agree that the Generator Owner and Transmission Owner are the appropriate entities to identify the Elements that meet the criteria in Requirement R2. However, we question the relevance or need to trace back to 2003 for Disturbances that caused an Element to trip due to a power swing or which formed the boundary of an island. Further, the term credible Disturbance needs clarification. Please see our comment under Q1, above.

No

R3 and its bulleted items need to be clarified that they apply to the load-responsive relays only, to be consistent with the purpose and scope of the standard, not the Protection System which could include other protective relays or components. However, if the standard is to ensure that Elements do not trip in response to stable power swings during non-Fault conditions, then all references to Protection Systems should be replaced with load-responsive relays. Bullet number four requires to prove dependable out-of-step tripping. However the entity may decide to use selective tripping when out- of-step conditions are detected. Studies show that in case of severe disturbance selective tripping when out-of step conditions are detected can increase the chance of creating successfully islands. We suggest changing the wording from "dependable out-of-step tripping" to "dependable out-of-step detection".

Yes

Yes

No

Individual

David Kiguel

n/a

No

1. The second criterion in R1 refers to "An Element that is associated with a System Operating Limit (SOL)." Clarification is necessary to specify the meaning of "associated." Does it refer to an Element in the SOL itself or monitored and protected but outside the SOL (or both)? 2. The draft repeatedly uses the term "credible event." In some instances, e.g. past disturbance(s) it might be subject to interpretation. In general, without a probabilistically quantified criterion, the term "credible" is subjective and subject to interpretation, thus should be avoided in this context. 3. Clarification is

required in regards to load-responsive relays in a Protection System. It is unclear as to what relays/components should not trip during power swing. 4. R2 requires GOs and TOs to evaluate Disturbance records "since January 1, 2003," a time that will precede the effective date of this standard. A requirement cannot rely upon records that precede the effective date of a standard.

Yes

Yes

Yes

Yes

Yes

The PSRPS document, developed by industry experts and approved by the NERC Planning Committee, clearly disputes the FERC directive in Order No. 773 (Docket No. RM08-13-000), that was subsequently affirmed in Order Nos. 773-A and 773-B, that a standard is needed to ensure that load-responsive protective relays do not trip in response to stable power swings during non-Fault conditions. NERC's informational filing in Docket No. RM08-13-000 dated July 21, 2011 concluded that there is a need for a standard on stable power swings. This conclusion is the opposite of what the PSRPS document concluded. The SPCS concludes that a NERC Reliability Standard to address relay performance during stable swings is not needed, and could result in unintended adverse impacts to Bulk-Power System reliability. I support the recommendation that the NERC Standards Committee explore means to utilize the more recent PSRPS document to obtain relief from the aforementioned FERC directive that is driving this project.

Group

SMUD/BANC

Joe Tarantino

No

(1) Collected data and subsequent analysis has not identified tripping during stable power swings. This phenomenon is rare if at all. Any tripping during stable power swings would more appropriately included as a mis-operation and addressed as such. (2) The requirement R2 is particularly unacceptable as it requires data for pre June 18, 2007; effective date of Order 693 standards.

No

Collected data and subsequent analysis has not identified tripping during stable power swings. This phenomenon is rare if at all. Any tripping during stable power swings would more appropriately included as a mis-operation and addressed as such.

No

The requirement R2 is particularly unacceptable as it requires data for pre June 18, 2007; effective date of Order 693 standards.

YES! The requirement R2 is particularly unacceptable as it requires data for pre June 18, 2007; effective date of Order 693 standards.



Individual
Richard
Vine
No
As "line-out conditions" used in Requirement R1 Criteria 1 and 2 is not a defined term, please clarify the intent of "line-out conditions", particularly addressing if "line-out conditions" are expected to go beyond the TPL Standard(s) of what the Planning Coordinator and Transmission Planner already study.
Individual
Chris Mattson
Tacoma Power
No
Tacoma Power supports PSEG's response to Question 1. Setting aside the previous comment (that is, assuming FERC does not provide relief from its directive to develop this standard), Tacoma Power supports a narrower approach. That is, the screening criteria should be refined and made simpler. For example, PRC-023 applies relatively straightforward screening criteria, yet PRC-023 addresses a greater reliability risk than the proposed PRC-026-1. Presently, PRC-026-1 Requirement R1 (and R2) could pose a greater burden on entities than PRC-023 for screening to identify applicable Facilities. Alternatives might be to conduct a data request to collect better information so that Requirements R1 and R2 could be consolidated and then provide more refined and simpler criteria. Setting aside the previous comment, Criterion 4 needs more clarification. What is the technical basis in Requirement R1 for identification and notification to occur in January of each year?
No
See Tacoma Power's response to Question 9. At least in WECC, not all of these entities may be appropriate to lead the identification effort.
No
Tacoma Power disagrees with the need for this standard.
No
Tacoma Power disagrees with the need for this standard. However, assuming FERC does not provide relief from its directive to develop this standard, the transient, rather than sub-transient, impedance may represent a better model. Granted, as noted in the Application Guidelines, the sub-transient impedance would yield a more conservative assessment.
No
Tacoma Power disagrees with the need for this standard. In particular, Tacoma Power has significant concerns with Requirements R1 and R2. It is therefore difficult to provide additional feedback on the VRFs and VSLs at this time.
No
: Tacoma Power disagrees with the need for this standard. In particular, Tacoma Power has significant concerns with Requirements R1 and R2. The Application Guidelines and Technical Basis do not provide sufficient clarification related to these two requirements.
No

Tacoma Power disagrees with the need for this standard. In particular, Tacoma Power has significant concerns with Requirements R1 and R2.

Tacoma Power disagrees with the need for this standard. However, assuming FERC does not provide relief from its directive to develop this standard, a regional variance should be considered, at least for WECC. The footprint of a typical Planning Coordinator or Transmission Planner in WECC may not be large enough to adequately perform the desired assessments in the planning horizon. Instead, it may be more effective to perform this analysis more regionally. The Reliability Coordinator may have a large enough vantage, but most of their focus is in the operating horizon.

Tacoma Power supports the spirit of PSEG's response to Question 3. Furthermore, Tacoma Power has the following, additional comments related to the January 1, 2003, date. 1) Not all Generator Owners and Transmission Owners may be required to retain records going back to January 1, 2003. 2) Apart from including the 2003 Northeast Blackout, no other technical justification has been provided for why the January 1, 2003, date was selected. Alternatives might be to indicate specific disturbances for which documentation likely exists or to conduct a data request to collect better information so that Requirements R1 and R2 could be consolidated and then provide more refined and simpler criteria. Setting aside the previous comment, does Requirement R2 Criterion 2 add any value beyond that provided by Criterion 1? If so, the term 'island' may need to be better defined. What is the technical basis in Requirement R2 for identification to occur in January of each year?

Individual

David Jendras

Ameren

No

(1) Along with our comments we agree with and adopt the Public Service Enterprise Group (PSEG) Comments by reference. (2) If this standard does proceed, we generally can accept the focused approach, but believe it should be narrower. We believe that R2 reaching all the way back to 1/1/2003 creates an ex post facto compliance obligation. (3) In our opinion R1 needs to limit the Criteria 3 and 4 time horizon to Operations Planning to be consistent with R3 which deals with the existing Protection System. We believe that resetting an existing relay for a future, but not present, stability issue could harm present reliability. Although, we do understand the benefits of identifying a future stability concern, and a future need to possibly alter relaying schemes or reset relays in an orderly fashion is important; we believe that such activity is part of the planning process and need not be governed by this standard. However, if the SDT intended that the R3 CAP (3rd bullet) apply to future scenarios, then please add the timing of such an example in the Application Guidelines. (4) We ask the drafting team to include a broader explanation of changed conditions that would discontinue credibility in R2, item 2 ("...during an actual system Disturbance where the Disturbance(s) that caused the islanding condition continues to be credible."). Include items such as completed PRC-004 CAPs that have fixed a contributing cause, and procedures to avoid a unique maintenance switching topology that was causal.

No

We believe that even if these are the right entities, it is unclear who is driving the identification process or if they even agree. Please change to 'Each Transmission Planner with the Planning Coordinator's and Reliability Coordinator's concurrence shall, within the first month of each calendar year, identify and provide notification to the respective Generator Owner and Transmission Owner of each Element that meets one or more of the following criteria...' In most cases, we believe the TP would identify these with their studies and therefore should take the lead.

Yes

No

Even though we may be able to accept and appreciate the SDT's approach; our recommended changes to this approach are as follows: (1) Change 1st sentence of Criterion to "Only load sensitive, high speed distance relays are within scope (e.g. zone 1 phase distance, pilot zone phase distance). For such a distance relay impedance characteristic, used for tripping, that is completely..." which adds the first sentence for clarity. We believe that this comment is consistent with the SDT's answers in NERC's 5/12/2014 webinar. (2) Change Criterion #3 to transient

reactance, because it aligns better with power swing time constants (see Reimert text pages 40, 289, 291, and particularly bottom of page 302). (3) Change 'once each calendar year' to 'within 2 calendar years of initial identification, and once every 5 calendar years thereafter' because once each calendar year is too frequent.

No

These are generally well written considering this complex situation that we feel is very rare, but we do have the following recommendations for the drafting team: (1) The variables in Figure 2 need to be defined; (2) The issue of aligning the planning assessment time horizon with present Protection System settings (see our 2nd comment Q1) needs to be clarified; (3) On page 24 change "the generator unsaturated generator X"d," to "the generator saturated generator transient reactance X'd," because transient time constant aligns better with power swing timeframe, and faults most often are the triggering event in such power swing scenarios (also see Reimert text pages 40, 289, 291, and particularly bottom of page 302). (4) On page 23 add "Overcurrent relays usually have long enough time delays that they can be excluded from consideration." at the end of the 'Application to Generator Owners' section. (5) To clarify when the simplified method instead of transient stability simulations can be used on page 24 in the last paragraph of the 'Impedance Type Relays' section change 'is' to 'can' and add "only" in the third line so it reads "The simplified method used in the Application to Transmission Owners section can also be used here to provide a helpful understanding of a stable power swing on load-responsive protective relays for only those cases where the generator is connected to the transmission system and there are no infeed effects to be considered."

No

(1) We request that the SDT provide a 1 year implementation period for R1 and R2 combined, followed by a 2 year implementation period for R3. (2) We believe that this standard poses a considerable burden on the TO and GO and the first pass may be a significant amount of work.

Group

Tennessee Valley Authority

Dennis Chastain

Yes

Yes

Yes

No

1) Every year is too often for this requirement. We recommend changing this to every 5 years. 2) We believe that the criterion is too specific for a regulatory document. It should allow entities to use their preferred methods for determining if a line is likely to trip during a stable power swing. Recommend changing the first bullet to: "...in response to a stable power swing based on either the criterion below or by another industry accepted method." 3) At the end of the fourth bullet it states "dependable out-of-step tripping". We recommend changing this to "dependable unstable power swing tripping".

Yes

Yes

Yes

Group
SPP Standards Review Group
Robert Rhodes
Yes
Establishing criteria that determine which Elements must be assessed according to Requirements R1 and R2 reduce the compliance burden on Generator Owners and Transmission Owners. This is the right approach. That said, we concur with AEP in that the SDT should limit the use of the term 'stability' in the standard to oscillatory and transient stability in order to avoid confusion with voltage and steady state stability.
No
The Reliability Coordinator may not be aware of Elements identified in Criteria 3 and 4, since that knowledge is based upon the Planning Coordinator or the Transmission Planner notifying the Reliability Coordinator of the situation. Yet the Reliability Coordinator is held accountable for the identification and notification '...of each Element that meets one or more...' of the criteria. Similarly, there may be situations where the Planning Coordinator or Transmission Planner may not be aware of Elements identified by the Reliability Coordinator yet they are also held accountable for identification and notification of each Element. There should be one, single list of all the Elements that satisfy the criteria but the responsible entities may not, individually, reach the same conclusions regarding the make-up of that list. Their individual lists may not contain all the Elements to be identified but a composite of all their lists should result in the one, true list of all Elements. The requirement needs to be modified to include this consideration.
Yes
No
We question the need for the annual assessment required in Requirement R3. PRC-005-2 satisfactorily covers the routine maintenance and testing of protective relays and this requirement would be redundant with those requirements. Additionally, only system changes (topology changes, load/generation changes, etc.) would impact the application of the relays applicable to this requirement. Thus they should only need to be reviewed or re-assessed if those types of changes occurred on the system. We suggest that the 4th bullet under Requirement R3 be made a notification rather than the existing agreement. As stated, the requirement for agreement places unintended risk on the Planning Coordinator, Reliability Coordinator and Transmission Planner. While we agree that if there is no dependable fault detection or out of step tripping the Planning Coordinator, Reliability Coordinator and Transmission Planner would need to be notified, we are unclear how these registered functional entities would have the knowledge of each applicable entity's protection systems to be able to agree to a correct relay setting. Would the fact that the Planning Coordinator, Reliability Coordinator and Transmission Planner accepted the settings place the responsibility of a cascading event due to the undependable fault detection or out of step tripping on the shoulders of these entities? This risk should be solely placed with the experts that design and maintain protection systems. Both a. and b. under the last bullet of Requirement R3 require the Generator Owner and Transmission Owner to obtain agreement with the Planning Coordinator, Reliability Coordinator and Transmission Planner yet nothing in the standard requires the Planning Coordinator, Reliability Coordinator or Transmission Planner to provide that agreement. Generator Owner and Transmission Owner compliance may hinge on that agreement but there is no incentive for the Planning Coordinator, Reliability Coordinator or Transmission Planner to reach that agreement. We concur with AEP in that rather than requiring agreement, the requirement should only require notification of the Planning Coordinator, Reliability Coordinator and Transmission Planner by the Generator Owner and Transmission Owner.
No
The VSLs for Requirement R1 should be changed in consideration to the point we made in our response to Question 2. Insert an 'an' between 'identified' and 'Element' in the VSLs for Requirement R2. References to 30-, 60-, and 90-calendar days should be hyphenated in the VSLs for Requirements R1, R2 and R3.

No
Requirement R2 calls for the responsible entities to identify Elements based on performance since January 1, 2003 which is before the effective date of the standard. During the webinar, the SDT indicated that although this requirement was included in the standard, it was not the intent of the SDT to hold the responsible entities accountable for this data. This exception should be included in the Application Guideline and especially in the RSAW. One-line diagrams for the examples in the explanations for Requirements R1 and R2 would be helpful. In the 3rd paragraph on Page 15, the SDT attempts to clarify the 2nd option under Requirement R3. The 1st sentence in the paragraph does just that. However, the next two sentences seem to go beyond the requirement by expanding the scope of the requirement. We propose to delete these last two sentences.
No
We would prefer to see the twelve months increased to twenty-four months to allow adequate time to complete all the studies and analyses that will be needed to comply with the standard.
We are not aware of any conflicts between the proposed standard and any regulatory function, rule, order, tariff, rate schedule, legislative requirement, or agreement.
We are not aware of any need for a regional variance or business practice.
We note that the SPCS concluded that this standard was not needed based on their review and analysis of past disturbances. They went on to say that such a standard '...could result in unintended adverse impacts to Bulk-Power System reliability.' Given their conclusion, has NERC and/or the SDT given any consideration to requesting FERC reconsider their directive to develop this standard? The following are comments on the draft RSAW. We recommend that a specific reference be made to the question of providing evidence based on experience prior to the effective date of the standard. Please see our response to Question 6 above. The industry needs assurances from NERC Compliance that auditors will not be holding responsible entities accountable for providing data on events that occurred prior to the effective date of the standard. The 1st and 2nd cells of the Evidence Requested and Compliance Assessment Approach tables for both Requirements R1 and R2 insert additional requirements that are not contained in the requirements in the standard. These items request evidence/documentation on the methodology and the utilization of that methodology by the responsible entity in the identification of the Elements called for in the two requirements. Neither Requirement R1 nor Requirement R2 mention anything about requiring the responsible entity to 1) have a methodology for performing that identification and 2) use the methodology in the identification process. These items need to be deleted from the RSAW along with the Note to Auditor under the Registered Entity Response for both Requirements R1 and R2. These notes refer to these two items. In the Note to Auditor under the Compliance Assessment Approach Specific to PRC-026-1, R2 replace the 'all' at the end of the 3rd line with 'a'. Still within this section, does the SDT concur with the interpretation of the example at the top of Page 9? If not, we ask that the SDT inform the RSAW developers.
Group
Southern Company: Southern Company Services, Inc.; Alabama Power Company; Georgia Power Company; Gulf Power Company; Mississippi Power Company; Southern Company Generation; Southern Company Generation and Energy Marketing
Wayne Johnson
Yes
Yes, in part. Addressing situations and occurrences of undesired relay operations is an appropriate method to minimize future undesired operations. The review period should be a rolling time period (previous 5 years) rather than > 10 years ago, as many entities will not have historical records to validate potential mis-operations. Entities were not required to keep such records to the date specified in R1 and R2. R1 #4 and R2 #1 should specify the inclusion of Elements that trip due to "stable power swings" instead of all power swings.
Yes
The PC, RC and TP, or some combination is the appropriate entity to identify elements that meet the criteria in Requirement R1. R1 should allow collaboration between the PC, RC and TP to produce a single list of Elements that will satisfy compliance for all three entities.
No

The TOs and GOs are the owners of the protection systems whose operation is being addressed, but the GO does not have a system view of stable power swings. Requiring the GO and TO to look back to 2003 every year as specified by R2 is unreasonable. Looking backwards to consider problems known to have occurred is understandable, but requiring this every year is not reasonable. These trip investigations have been occurring in the industry long before the mandated PRC-004 operation reviews. Most responsible utilities have addressed undesirable protection system misoperations to maximize availability - the market forces have long driven utilities to correct undesirable relay operations so they can be available to the market.

No

The method defined in R3 should be an option for determining susceptibility of a given relay, but the requirement should be for the responsible entity to develop criteria to determine susceptibility of a given relay to tripping for stable power swings and then other requirements to demonstrate the adherence to and compliance with those criteria. If the prescriptive method of R3 remains in the standard, R3, bullet #4 (b), should explicitly state that it is acceptable for the modifications specified in the CAP not to result in meeting the criteria of R3.

Yes

The requirement language should be finalized before establishing VRFs, VSLs. and measures.

Yes

Yes, provided the R2 review period begins with the enforcement date of the standard looking forward.

We are not aware of any conflicts.

We are not aware of any needs for exceptions.

a) The phrase "continues to be credible" in R2 needs explanation. Is the intended meaning either 1) the trip was believed to be caused by the Disturbance, 2) a repeat trips susceptibility continues to be possible or likely, or 3) something else? b) Is the consequence of R2/M2 having to analyze and document every relay operation (trip) which occurs for determination of if it was caused by a system Disturbance? Also, do all system Disturbances have to be reviewed for possible relay (trip) operations, for subsequent validation of desired operation? The NERC glossary definition of a Disturbance is very much open-ended and not specifically defined in part 2: "2. Any perturbation to the electric system." Is this requirement duplicative of PRC-004 relay mis-operation determination? Does PRC-026 subject entities to possible violation of two standards for a single possible (lack of) action? c) An annual requirement for R1, R2, and R3 seems excessive. Extended periodicity intervals or triggers from system topographic changes should be considered rather than annual reviews. For example, PRC-006 and PRC-010 prescribe evaluation intervals of 5 years for UVLS and UFLS. Five years seems to be a reasonable interval for this analysis. d) Does any specific item on the Identified Element list ever get removed from the list? The resolution of a review in a previous year should eliminate it from future reviews.

Group

ISO RTO Council Standards Review Committee

Greg Campoli

No

Conditions (2) and (3) are unclear. Condition (2) stipulates that the responsible entity notify the facility owner of an Element that is associated with a System Operating Limit (SOL) that has been established based on stability constraints. It's not clear whether the Element is the contingent Element or the monitored Element or both. This needs to be clarified/specified in the standard/requirement. Condition (3) stipulates that the responsible entity notify the facility owner of an Element that has formed the boundary of an island within an angular stability planning simulation where the system Disturbance(s) that caused the islanding condition continues to be a credible event. The term "credible event" is hard to determine since the Disturbance could be caused by one of those events listed in the TPL standards, or could be one that is beyond those listed, such as natural phenomena. We realize that the Application Guideline provides some general guidance on assessing the credibility of a Disturbance, but we do not agree that a Disturbance is no longer credible when it is deemed no longer capable of occurring in the future due to actual changes to the BES. Changes to the BES may reduce the possibility of the same Disturbance, but such Disturbances

(e.g. loss of right of way or an entire station) may still occur due to other means. If the SDT should continue to hold the position that the criteria for excluding a Disturbance is that BES changes are made to mitigate (but not totally eliminate) the recurrence, then it should be clearly stated in the requirement itself. In short, the basis with which to deem a Disturbance "credible" is missing from the requirements, which needs to be provided/clarified in the standard/requirement.

No

These three entities are appropriate for the R1 requirement. However, there should be a requirement that only one of the three is deemed responsible to provide notice to the facility owner. Every facility that falls under the R1 criteria is under the authority of all three entities. It would be repetitious and redundant to require all three entities to provide the same information to the same facility owner. However, if the intent of the requirement is that the Reliability Coordinator will address the Operations Planning Horizon, while the Planning Coordinator and Transmission Planner will address the Long-Term Planning Horizon, then it may not be repetitious nor redundant to require these entities to address Requirement R1. Also, the entity who is registered as the RC may differ from the entity who is registered as the PC and TP. For example, in the Western Interconnection, Peak Reliability is the RC, the CAISO is the PC for much of California (but not all), and the Participating Transmission Owners are registered as the TP. In CAISO's case, the three registered entities of RC, PC, and TP are represented by different entities.

No

We ask whether the TO or GO, especially a GO, will have access to studies and fault analysis reports that will determine if the Disturbance remains credible. There seems to be an assumption in R2 that a fault analysis study was performed that documents the Disturbance and system conditions at the time. There must be a requirement in some NERC standard that obligates appropriate entities are notified of these results. We are unclear on the relevance or need to trace back to 2003 for Disturbances that caused an Element to trip due to a power swing or which formed the boundary of an island. Further, the term credible Disturbance needs clarification. Please see our comment under Q1, above. This requirement should not be written with a date specific start point. Over time, this date would be meaningless and inappropriate for applying the standard. Instead this requirement could be written in a rolling calendar basis, e.g. – "prior twelve months".

No

R3 and its bulleted items need to be clarified that they apply to the load-responsive relays only, to be consistent with the purpose and scope of the standard, not the Protection System which could include other protective relays or components. However, if the standard is to ensure that Elements do not trip in response to stable power swings during non-Fault conditions, then all references to Protection Systems should be replaced with load-responsive relays. We are concerned that holding relay engineers to limit load-responsive protection schemes to meet these settings in order to be compliant may not always be in the best interest of bulk power system reliability. Although it is good practice to see that facilities can withstand transients that are expected to dissipate and not pose a recurring threat to the grid, requiring these settings to always be adhered to takes away the ability for the relay engineer to apply engineering judgment if there are conflicting needs to allow for tripping the load-responsive relays in order to protect from another more imposing system threat. These relays are primarily to protect from a specific condition identified by studied and credible faults. This setting may be inside the trip circle identified by the stable power swing. In these cases, the relay engineer makes a best judgment to ensure a balance between which threat is more relevant or immediate to make the appropriate setting. The standard should allow for entities to provide technical evidence that a load-responsive relay may have to be set within a trip circle of a stable power swing, if there is no other protection scheme available to mitigate the primary threat.

Group  
Dominion

Mike Garton
Yes
Yes
Yes
No
Item b under the 4th bullet in Requirement R3 is not stated using clear and unambiguous language whereby responsible entities, using reasonable judgment, are able to arrive at a consistent interpretation of the required performance. The R3 rationale and the Protection System Response to Power Swings technical document provide some clarity; however, the simple fact is the 4th bullet is not clear and troublesome from a compliance perspective. Dominion suggest revising the 4th bullet to ensure the responsible entity understands the balance between security and dependability and how that is to be achieved by either sub-parts a or b.
Yes
Yes
Yes
No
No
Dominion suggests that Associated Documents (at least those where there are no copyright concerns) be included in the standard as attachments or appendices as we are concerned that cited URLs will change over time. Requirement R2 Criteria 1 and 2 require review of Disturbances since January 1, 2003. While Dominion recognizes the desire to consider Disturbances since January 1, 2003 in order to capture the August 14, 2003 Blackout, it is important to note that NERC Reliability Standards were not mandatory at that point and data may or may not be available. Dominion recommends changing the criteria dates to June 18, 2007 to be consistent with the establishment of mandatory and enforceable Reliability Standards.
Individual
Scott Langston
City of Tallahassee
Individual
Bob Thomas
Illinois Municipal Electric Agency
Individual
Bill Fowler
City of Tallahassee
Individual
John Pearson
ISO New England
No
ISO New England recommends that requirements R1, R2, and R3 be changed from an annual requirement to once every 60 months. We also think that the approach should be narrower. • Criteria 1 should be limited to IROL's and read as follows: 1. An Element that is located or terminates at a generating plant, where a generating plant stability constraint exists and is addressed by an IROL. • Criteria 2 should be deleted. This criteria appears to be redundant to Criteria 1. • In Criteria 3, Disturbance is too broad. It should be limited to single or multiple contingencies but not extreme contingencies. Criteria 3 should read as follows: 3. An Element that has formed the boundary of an island within an angular stability planning simulation where the



system Disturbance(s) that caused the islanding is a single or multiple contingency but not an extreme contingency. • Criteria 4 should be narrower in scope and read as follows: 4. An Element identified in the most recent Planning Assessment where relay tripping occurred for a power swing during a Disturbance caused by a single or multiple contingency but not an extreme contingency. Again, Disturbance is too broad. It should be limited to single or multiple contingencies but not extreme contingencies.
Yes
No
In R2, it is unrealistic to require an entity to provide data on an Element that had tripped since 2003. There is no existing NERC continent-wide disturbance monitoring or misoperation standard that requires data be retained more than 12 months. We recommend that this requirement be removed from the standard or include only Elements that were tripped in the last calendar year.
No
The option under the fourth bullet requires that the Generator Owner and Transmission Owner obtain agreement from the respective Planning Coordinator, Reliability Coordinator and Transmission Planner of the Element that either: (a) the existing Protection System design and settings are acceptable, or (b) a modification of the Protection System design, settings or both are acceptable and develop a corrective action plan for this modification of the corrective action plan. This requires specialized knowledge and coordination that is not typical for Planning and Reliability Coordinators.
Yes
No
While the Application Guidelines and Technical Basis provide guidance, we disagree with the current roles of functional entities to which the standard applies.
No
Given that the currently proposed scope of the standard is very broad, twelve months is not a long enough timeframe to become compliant with the requirements of this standard, which will create additional workload for the functional entities subject to the standard. ISO New England suggests 36 months.
Group
ACES Standards Collaborators
Jason Marshall
No
(1) This requirement needs to be further clarified that it is not intended to require additional studies. Rather, the TP, PC and RC are to identify the information in bullets 1 through 4 based on their existing knowledge and studies. (2) Part 2 needs further clarification regarding which SOLs should be applied. Are the SOLs established from the planning horizon per FAC-010-2.1 or the SOLs established in the operating horizon per FAC-011-2 applicable? We recommend that only SOLs from the operating horizon should be applied because the SOLs from the planning horizon may include the impact of proposed or retired facilities which could result in unnecessary relay modifications or miss necessary relay modifications. (3) Requirement R1 as a whole is problematic because it is based partly on planning studies. Planning studies include proposed system additions and retirements which could result in the identification of unnecessary relay modifications or a failure to identify necessary relay modifications. (4) R1 should be split based on responsibilities. Some of the bullets should apply to only one entity. For example, an RC is required to monitor the status of Special Protection Systems per IRO-005-3.1a R1.1. The RC would also have to be aware of generating plant stability constraints. Thus, the RC could provide all of the information for bullet 1. Bullets 3 and 4 are based on planning studies and should only apply to the Planning Coordinator. If only SOLs from the operating horizon are to be evaluated, then bullet 2 should only apply to the RC. (5) Part 2 should be modified to limit application to IROs and not all stability related SOLs. By

definition, if an SOL is stability related and is not an IROL, it cannot have a wide area impact on reliability and is limited to local reliability. If it had a wide area impact, it would cause "instability, uncontrolled separation or Cascading outages that adversely impact the reliability of the Bulk Electric System" and would be an IROL. (6) Part 4 is problematic because it now requires relay tripping to be evaluated in transient studies performed by the Planning Coordinator and Transmission Planner. These entities may not include all relays in their studies but this part creates a de facto requirement for them to include all relays. Otherwise, how can a PC or TP determine if relay tripping would occur? (7) The language of the requirement needs to be clarified that the TP, PC and RC are to only identify elements in their area. This could be accomplished by adding "in its area" after "each Element." (8) The format of the sub-part numbering does not follow the convention that NERC established several years ago and notified the Commission that it would use for sub-parts. When all sub-parts are required then they are to be numbered. When only one sub-part is requirement (i.e. one of the list has to be selected), they are to be bulleted. The draft appears to stray because of the language "one or more" in the main requirement. In other words, one item could be met or more than one. However, we argue that bullets should be used because while more than one could apply, if one applies the Element is to be identified by the PC, TP, or RC. There is no additional need for any tests once one is met. Thus each Element will only be identified as meeting one of the bullets because that means it qualifies even though it could meet more than one. (9) Why can't the islanding evaluation conducted per PRC-006-1 R1 be used as the basis for identifying Elements rather than writing a new bullet 3 in the requirement?

No

We do not believe that the Transmission Planner should be an applicable entity. Any studies completed by the TP will be duplicated in a larger PC study thus making the inclusion of the TP unnecessary.

No

(1) We do not believe the GO or TO are appropriate entities. In fact, we do not believe any entity is appropriate to identify the Elements in R2 and that the requirements are not enforceable as written. NERC cannot compel evidence from dates prior to June 18, 2007, which is when FERC approved the first set of reliability standards. Furthermore, a new standard cannot compel data and evidence from before a time period that the standard was in effect. In today's litigious society, many companies have data retention programs that result in the destruction of data that is not required to be retained. Thus, GOs and TOs may not have the data. How would they comply? We simply will never be able to support a standard requiring data retroactively. (2) The topology of the transmission system has changed significantly in many areas since the January 1, 2003. That is over 11 years from the drafting of the standard. It is simply unreasonable to assume that power swings that occurred in 2003 would occur in the same way and that the data is still applicable. Relying on 11-year old data simply does not provide a sound engineering basis. (3) The islanding analysis conducted for PRC-006-1 R1 would form a better basis for identifying these Elements and could be used in place of this requirement. The PC could notify the TO and GO of the Elements at the boundaries of the islands and R2 could then be removed avoiding the issue of retroactive compliance.

Yes

(1) We agree generally with the approach but note that there are specific issues. (2) First, we disagree with the sub-bullet requiring the GO or TO to obtain agreement from the PC, TP, and RC to retain existing Protection System settings to maintain dependable fault detection. Dependable fault detection is a safety issue. A TO or GO should not have to get agreement to maintain Protection System settings that are safe. The TO and GO should notify the PC, TP, RC and TOP of such issues and then the PC and TP can plan the system accordingly (i.e. meet the TPL standards) and the TOP can operate the system accordingly (i.e. meet the IROL standards). (3) Obtaining the agreement of the PC, RC, and TP is problematic and repeats similar problems that are associated with PRC-023 R3. PRC-023-2 R3 requires the GO, TO, and DP to obtain the agreement of the PC, RC and TOP to set the relay loadability using certain criteria. The problem is there is no obligation for the PC, RC or TOP to agree and they often are reluctant to agree due to legal liability. In other words, no one really knows what they are agreeing to or the implications except that the standard requires it. These same problems will be experienced here with this requirement. The need for the PC, TP and RC to agree should be removed or more specification should be provided for what this means. (4) For the criterion, we disagree with the need to require the PC, RC, and TP to agree to use a system

separation angle of less than 120 degrees. All that should be required is for the TO or GO to provide sound engineering justification for using an angle less than 120 degrees.

No

(1) We agree that the VRFs for Requirement R1 through R3 should be no higher than medium. To be higher than medium, a violation of the requirement would have to lead directly to cascading, instability or system separation. Power swings were not direct causes to the August 14, 2003 blackout but rather occurred after other events had already happened. (2) We disagree with the VRF for Requirement R4. Requirement R4 is an administrative requirement to update paperwork (i.e. update the CAP). It does not and should compel completion of the CAP because it is impossible to complete construction by a certain date due to the unpredictability (e.g. weather, logistical, legal, or operational delays) of issues that delays construction. (3) We cannot agree with the VSLs because we do not agree with the requirements. Furthermore, the VSLs anticipate that the only violation that could occur is a time violation. VSLs that are not just time-based need to be written.

No

(1) In general the guidelines provide a good explanation; however, we do identify some suggested improvements below. (2) We suggest modifying the end of the "Applicability" section on page 13 to clearly state that these load-serving facilities by definition would not be part of the BES. Thus, standards would not apply. (3) The last sentence of the "Requirement R1" section on page 14 is too vague. As written, it could be interpreted that the PC and TP must include any Elements identified in the Planning Assessment for any reason (i.e. including non-power swing issues). This is inaccurate. Part 4 of the requirement is very specific to only those Elements with relays that trip due to stable power swings as identified in studies. Please update the guidelines to match the language of the requirement more closely.

No

(1) We disagree with the implementation plan and believe that a staggered implementation is necessary. If the standard were approved such that it would become effective on March 1, 2016, the TO and GO would not have any Elements identified per R1 until approximately 10 months later in January 2017. How could they comply in 2016 with R3 when they don't have any Elements identified per R1?

(1) Requirement R4 is unnecessary and inconsistent with the Reliability Assurance Initiative which is attempting to move NERC away from paper-driven compliance to reliability-driven compliance. The only practical violation of R4 will be a failure to update the paperwork. As written, if an implementation date slips, the TO or GO can update their CAP. We agree they should have the flexibility to do this since construction schedules nearly always have to be adjusted. Thus, if a milestone is not completed for any reason, a violation will not occur unless the CAP is not updated. How does this support reliability? Because it is not practical to require a TO or GO to complete their CAP by the dates established in the initial version due to unpredictable changes and unforeseen circumstances always faced in construction, the only real practical solution is to remove Requirement R4. NERC and the Regional Entities have the authority to request copies of the CAPs and progress reports and have other methods to encourage completion of CAPs if they are not satisfied with the progress. (2) We are concerned that the RSAW is not consistent with the principle of the Reliability Assurance Initiative (RAI). RAI is intended to refocus NERC's compliance efforts to be forward looking rather than backwards looking and focus on the matters that impact reliability the most. This RSAW has reverted to the historical looking compliance review. On every requirement, there are multiple statements that evidence will be requested for each calendar year since the last audit and that the compliance assessment approach will evaluate every year since the last compliance audit. For a TO or GO, this would represent six to seven years of evidence and review that would provide no reliability benefit. This RSAW needs to be revamped to be consistent with RAI principles. (3) Thank you for the opportunity to comment.

Group

FirstEnergy Corp.

Richard Hoag

No

FirstEnergy agrees with the focus approach using the criteria but has the following concern. It is understood that the "... since January 1, 2003" verbiage is intended to capture applicable relay operations during the Aug. 14, 2003 event. It will be difficult if not nearly impossible for a GO, especially in a deregulated environment, to piece together details of relay operations prior to record-keeping requirements for NERC PRC-004. We recommend that these Criteria be reworded to include only incidents which have occurred since the inception of NERC PRC-004.

Yes

No

It is understood that the "... since January 1, 2003" verbiage is intended to capture applicable relay operations during the Aug. 14, 2003 event. It will be difficult if not nearly impossible for a GO, especially in a deregulated environment, to piece together details of relay operations prior to record-keeping requirements for NERC PRC-004. We recommend that these Criteria be reworded to include only incidents which have occurred since the inception of NERC PRC-004.

No

It would be most helpful to specify protective functions (e.g., 78, 21, 67, 40?) to be included in this analysis, similar to what was done with the Criteria Tables in PRC-025. If the reference to "load-responsive protective relay" in PRC-026-1 R2 means the same as where this terminology is used (and defined) in PRC-025, the scope of work required for the detailed analysis specified in PRC-026-1 R3 is quite significant. Technical resources to perform this analysis on each applicable relay could be difficult for many GOs to commit or obtain, and it would be difficult to accomplish the analyses in a short timeframe. One year is unrealistic, especially considering the concern stems from an incident that occurred nearly eleven years ago. Further, an annual demonstration with associated evidence is potentially financially burdensome, and seemingly unnecessary if there are no changes to a Unit's protection system. Changes to applied protection are already captured via the coordination requirement in PRC-001, and are available to the PC, RC and TP. Again, in a regulated vs. competitive environment, it may be difficult to obtain system data needed for such calculations. However, if the only piece of information needed from the TO is a Thevenin impedance (system equivalent) at the Point of Interconnection, acquiring this should not be a problem.

Yes

No

It would be most helpful to specify protective functions (e.g., 78, 21, 67, 40?) to be included in this analysis, similar to what was done with the Criteria Tables in PRC-025. If the reference to "load-responsive protective relay" in PRC-026-1 R2 means the same as where this terminology is used (and defined) in PRC-025, the scope of work required for the detailed analysis specified in PRC-026-1 R3 is quite significant. Technical resources to perform this analysis on each applicable relay could be difficult for many GOs to commit or obtain, and it would be difficult to accomplish the analyses in a short timeframe. One year is unrealistic, especially considering the concern stems from an incident that occurred nearly eleven years ago. This requirement should also be worded in such a way as to be sensitive to GOs operating in a competitive environment, where FERC Standard of Conduct issues make it difficult if not impossible to even know about power swings or other disturbances on the power system. Please define "stable power swing". The diagrams ("Figures") in the Application Guidelines appear to be typical. Is there enough information contained in the Application Guidelines that a GO can determine Power Swing Stability Boundaries for each specific application?

No

This current situation has continued for 11 years and an implementation plan of 1 year is unrealistically short. Two years is more appropriate unless the period is modified to include only incidents which have occurred since the inception of NERC PRC-004 then 1 year would be reasonable.

In a competitive/unregulated environment a GO does not have access to the information pertaining to power swings (stable or otherwise) due to the FERC Standard of Conduct. Therefore the GO would not know the cause of a relay operation.

None

None

Group
Florida Power & Light
Mike O'Neil
Yes
The language for Criteria 3 & 4 in Requirement 1 should be modified. Criteria 3 should consider underfrequency planning simulations in addition to angular stability planning simulations. Criteria 4 should consider Planning Assessments in the last year as opposed to "the most recent Planning Assessment."
Yes
Yes
Yes
Yes
Group
PPL NERC Registered Affiliates
Brent Ingebrigtsen
Yes
These comments are submitted on behalf of the following PPL NERC Registered Affiliates: LG&E and KU Energy, LLC; PPL Electric Utilities Corporation, PPL EnergyPlus, LLC; PPL Generation, LLC; PPL Susquehanna, LLC; and PPL Montana, LLC. The PPL NERC Registered Affiliates are registered in six regions (MRO, NPCC, RFC, SERC, SPP, and WECC) for one or more of the following NERC functions: BA, DP, GO, GOP, IA, LSE, PA, PSE, RP, TO, TOP, TP, and TS Comments: We agree with the general approach, but have some implementation concerns as expressed below.
Yes
No
We agree with R2 in principle, but there are presently some barriers to the specified stand-alone nature of GO and TO obligations: - R2 should state that, where Elements meet one or more of criteria 1-4, the TO must provide GOs with the system impedance data necessary to perform their studies (ref. the comment on p.24 of the Application Guidelines regarding taking into account the strength of the transmission system). GOs typically do not have automatic access to this data, and their "firewall" separation from TOs may impede such an information exchange unless it is mandated by NERC standards. - There has been to-date no obligation for entities to maintain records pertaining to the criteria specified in R2, so it may not be possible in all cases to perform the look-back to Jan. 1, 2003 mandated in this requirement. The criteria should therefore be changed to begin, "An Element that is known to have..," instead of, "An Element that has...." - GOs may not know whether their Elements formed the boundary of an island (ref. R2.2GOs should not be required to take any actions under either R2.1 or R2.2 until and unless the PC/RC/TOP gives notification and provides the relevant necessary information to the GO.
No
We agree with R3 in principle, but there are presently some barriers to the specified stand-alone nature of GO and TO obligations: - The statement, "Demonstrate that the existing Protection System is not expected to trip in response to a stable power swing based on the criterion below," in R3 should be replaced by, "Demonstrate that the existing Protection System is programmed per the

criterion below." The reason for this change is that, while the criterion on p.6 of PRC-026-1 is the appropriate "textbook" way of setting-up an out-of-step relay, the genuinely authoritative means of showing that tripping will not occur for stable power swings is by use of a transient stability program as discussed in the first paragraph on p.24 of the Application Guidelines. Such programs are far from simple to set-up and operate however, GOs do not typically have or run them, and the system data required is known only to the TO and TOP. The requirements and Application Guidelines should make it clear that GOs have no involvement with transient stability programs. - The statement, "For cases where infeed affects the apparent impedance (multiple unit connected generators connected to a transmission switchyard), the Generator Owner will provide the unit and relay data to the Transmission Planner for analysis," indicates that compliance responsibility can as a matter of practicality shift to another entity under certain circumstances, but the requirements do not ensure that such transactions happen. The, "obtain agreement," alternatives under the 4th bull-dot of R3 do not obligate the PC/RC/TOP to perform studies or take other actions to help facilitate compliance under R3. PRC-026-1 needs revision to explicitly define the circumstances and mechanisms for multiple-entity collaboration in performing analyses.

No

The VSL for failure to identify an Element in accordance with R2 needs to take into account the potential impossibility of performing a look-back to Jan. 1, 2003, as stated above.

No

In addition to our comments elsewhere in this document, the term, "load-responsive protective relays," needs definition, especially since its meaning appears to change from one standard to another. We view "out-of-step" devices as not being among the load-responsive protective relays governed by PRC-025-1, for example, but being included under PRC-026-1. Is the list on p.23 of the Application Guidelines meant to be exclusive?

No

It is not evident why applicable Elements owned by GOs require a new R3 analysis annually. Their calculations should remain valid until and unless impedances change significantly. We suggest that the TO should provide a system impedance update annually (ref. comment #2 above), and a new study should be required of the GO only if the generator, GSU or system impedance changes by 10% or more.

No.

No.

Individual

Chris Scanlon

Exelon

Yes

Yes

Yes

Yes

Yes

Yes

Yes

The SPCS white paper "Protection System Response to Power Swings" (August 2013), found, "Based on its review of historical events, consideration of the trade-offs between dependability and security, and recognizing the indirect benefits of implementing the transmission relay loadability standard (PRC-023), the System Protection and Control Subcommittee (SPCS) concludes that a NERC Reliability Standard to address relay performance during stable swings is not needed, and could result in unintended adverse impacts to Bulk-Power System reliability." Notwithstanding that recommendation, the white paper also outlined an approach for developing a power swing reliability standard in the event a standard is proposed to address the FERC Directive. We agree that the SDT has adhered to the SPCS's recommendations in the present draft, but we do not believe that the technical basis for the SPCS recommendation against creating a standard has been challenged and that there is sufficient justification for continuing with the effort to write a standard addressing this issue. To the best of our knowledge, our operating companies, ComEd, BGE and PECO, have never experienced a relay trip due to a power swing. We recognize and appreciate the Drafting team's work in responding to comments to the SAR suggesting that alternative means of meeting the Directive should be explored. As discussed by numerous stakeholders in the previous response to comments, we believe further work in this area should continue.

Group

Duke Energy

Michael Lowman

No

(1) Based on the SPCS report stated below (dated August 2013), Duke Energy does not believe that adequate technical justification has been identified for this project to become a standard. The SDT and NERC should consider moving this project to a Guideline document until such time as a standard is warranted. "Based on its review of historical events, consideration of the trade-offs between dependability and security, and recognizing the indirect benefits of implementing the transmission relay loadability standard (PRC-023), the SPCS concludes that a NERC Reliability Standard to address relay performance during stable power swings is not needed, and could result in unintended adverse impacts to Bulk-Power System reliability." (2) Duke Energy does not agree with the criteria specified in R1 because sufficient tools have not been developed at this time for the industry to conduct the appropriate assessment and identification of the Elements in Criteria 4. However, if this project moves forward as a standard we suggest the following revision to Criteria 4: "4. An Element identified in the most recent Planning Assessment where relay tripping occurred as a result of a power swing during the simulated Disturbance. Generic modeling of relays is acceptable when conducting this initial Planning Assessment." This would provide the necessary flexibility until such a time as tools are developed to conduct a more accurate Planning Assessment and identification of Elements for Criteria 4.

No

Duke Energy disagrees with the applicability of the Reliability Coordinator (RC) to Requirement R1. From a NERC Reliability Functional Model standpoint, the RC does not directly interface with a Generator Owner (GO) or Transmission Owner (TO) as Requirement R1 is proposing. The RC receives facility and operational data such as maintenance plans from TOs and GOs for reliability analysis, but this is mostly done through automation i.e. SDX (System Data Exchange). The Functional Model even states that the RC coordinates with other RCs, Transmission Planners, and Transmission Service Providers on transmission system limitations, not to TOs or GOs. Communication from an RC is most always directed to the Balancing Authority (BA) or Transmission Operator (TOP), and the RC reliability analyses is provided to TOPs, BAs and Generator Operators in its area as well as other RCs. An RC, per FAC-011, is required to establish a methodology for the identification of SOLs/IROLs and communicate the methodology to the TOP. RCs assist TOPs in calculating and coordinating SOLs, but the TOP is the Functional Entity that implements the RC methodology to identify and communicate the SOLs/IROLs to its RC in the Operations Horizon. Lastly, we feel that this standard would create a precedent requiring the RC to unnecessarily communicate and interface with GOs and TOs; an action that is not required by the current enforceable Reliability Standards. We recommend that the TOP should supplant the RC as the applicable entity responsible for communicating the criterion list in the proposed PRC-026-1 Requirement R1. Duke Energy proposes the following alternative language for Requirement R1. "Each Planning Coordinator, Transmission Operator, and Transmission Planner shall, within the first

month of each calendar year, identify and provide notification to its Reliability Coordinator, and to the respective Generator Owner and Transmission Owner of each Element that meets one or more of the following criteria, if any: "

Yes

Duke Energy does not agree with the TO and GO combing through 12 years of historical data and determining the events that were a result of a power swing. In addition, the GO and TO would have to maintain documentation of power swing events that have occurred since 2003 for every compliance audit. This would cause an unnecessary administrative burden on the responsible entity and should be viewed as a P81 candidate. A more appropriate set of criteria would be for the TO and GO to identify Elements in R2 that have occurred in the previous calendar year or in the previous audit cycle.

Yes

Yes

No

On page 16 of the Application Guideline and Technical Basis document, paragraph 3 states, "...the Element passes the evaluation (Figures 6 and 7)." However, Figure 7 on page 23 states, "This Element does not pass the Requirement R3 evaluation." It appears that Figure 7 is incorrect with the statement on page 16.

Yes

Duke Energy would like to reiterate that we do not believe adequate technical justification has been identified for this project to become a standard. Based on the SPCS recommendation, the SDT and NERC should consider moving this project to a Guideline document until such time as a standard is warranted.

Individual  
Shivaz Chopra  
New York Power Authority

No

The PSRPS technical document does not recommend this Standard. This is stated in pages 5, 20, and 24: "Based on its review of historical events, consideration of the trade-offs between dependability and security, and recognizing the indirect benefits of implementing the transmission relay loadability standard (PRC-023), the SPCS concludes that a NERC reliability Standard to address relay performance during stable power swings is not needed, and could result in unintended adverse impacts to Bulk-Power System reliability." We only agree with R1. R1 calls upon the Planning Coordinator, Reliability Coordinator, & Transmission Planner, (all single ISO in our region) to provide notification to GOs and TOs of what the specific "Elements" are. R2 seems to again call for Elements by the GOs and TOs. R2 can easily be combined into R1 for a simpler answer. In addition, by practice all registered entities report to the ISO/RC any disturbances, being they are the System Operator and keep records of events in the region.

Yes

The Planning Coordinator, Reliability Coordinator, and Transmission Planner would have the necessary data and capabilities to perform such functions for internal control areas and interregional ties.

No

The Planning and Reliability Coordinator (ISO in our region) would have records of such disturbances for their control areas. TOs and GOs defer to the ISO to render all final decisions and designations in these types of matters.

No



The more relevant approach, as is recommended by the PSRPS technical document, is that you do take corrective actions for unstable power swings. This was determined to be a far greater concern than not taking actions for stable swings. A more accurate description of "load responsive" protective relays is also necessary. This Standard seems to just repeat what is in the PSRPS technical document, without the necessary elaborations needed for proper understanding.
No
We do NOT agree with the need for this standard.
No
This proposed Standard would be better suited as a TPL, or OP Standard, not a PRC one. This is because the functions and study capabilities required for the Standard are done by Transmission Planning/Operations Organizations, and are not in the realm of Protective Relay Departments of a GO/TO.
No
Implementation periods should be consistent with the more relevant approach described in the PSRPS technical document.
As previously answered, the referenced 61-page PSRPS technical document, from which much of this Standard's wording is copied from, specifically recommends against this standard. Again, as stated in Pages 5, 20, and 24: "Based on its review of historical events, consideration of the trade-offs between dependability and security, and recognizing the indirect benefits of implementing the transmission relay loadability standard (PRC-023), the SPCS concludes that a NERC reliability Standard to address relay performance during stable power swings is not needed, and could result in unintended adverse impacts to Bulk-Power System reliability."
Group
BC Hydro
Patricia Robertson
No
Any approach should be based on experience with improper operation during stable power swings. If there has been no experience of undesired operation during stable power swings then checking against the criteria just results in fruitless work.
No
BC Hydro does not agree that the criteria of R1 are reasonable. Therefore cannot suggest why an entity is not appropriate.
No
BC Hydro does not agree that the criteria of R2 are reasonable. Only experience of tripping during STABLE power swings should be used.
Yes
No
BC Hydro does not agree with R1 and R2, therefore do not agree with violation risk factors or violation severity levels.
No
The technical basis should be improved to apply only to cases where stable power swings have historically caused undesirable tripping of transmission lines.
No
BC Hydro does not agree with implementation of the proposed standard at all.
The WECC region should be exempt from this rule. In this region, transmission power along many lines is subject to stability limits. It is an unnecessary use of resources to check the stability of protection systems on so many lines, considering there have been a negligible number of undesirable trips on stable power swings.

Since the SPCS has concluded that no lines were tripped due to stable power swings, in any of the major disturbances, the FERC directive is flawed, and this regulation should not be implemented.
Individual
Roger Dufresne
Hydro-Quebec Production
Group
JEA
Tom McElhinney
Individual
Gul Khan
Oncor Electric Delivery LLC
No
Oncor does not agree that the approach of this Standard came from recommendations in the PSRPS technical document, but rather negates the need for the Standard altogether. Specifically, on page 5 paragraph 4 of the document it states "Based on its review of historical events, consideration of the trade-offs between dependability and security, and recognizing the indirect benefits of implementing the transmission relay loadability standard (PRC-023), the SPCS concludes that a NERC Reliability Standard to address relay performance during stable power swings is not needed, and could result in unintended adverse impacts to Bulk-Power System reliability". Oncor agrees with this notion and does not want to add any adverse issues to the power system. This is also repeated on page 20 paragraph 1. In regards to the specific requirements, R1 criteria 1 states "An Element that is located or terminates at a generating plant, where a generating plant stability constraint exists and is addressed by an operating limit or a Special Protection System (SPS) (including line-out conditions)." This requirement duplicates the efforts in TPL-002 (R1.3.10), TPL-003(R1.3.10), TPL-004(R1.3.7), and TPL-001-4(R 2.7.1) where the effect of a SPS, which is a protection system, is already studied. Oncor recommends the SDT aligns the Requirements to eliminate duplication.
Yes
Oncor agrees that the three registered functions defined are those that should identify the elements in R1; however, if each criterion, except for criteria 4 as it would clearly come from the Transmission Planner, is assigned to a registered entity it would provide a more clear process. Additionally, R1 calls for "within the first month of each calendar year, identify and provide notification to the respective Generator Owner and Transmission Owner of each Element that meets one or more of the following criteria, if any" and then looking at criteria 1 and 2, Oncor recommends the SDT clarify the time frame, either real time/short term or future/long term, required. The Time Horizon does state "Long-term Planning" but it also calls for identification of the element within the first month of the calendar year. This would assist with whether or not planning data, which is done one year out, would be valid. See "line out condition" statement in Oncor's response to #6.
Yes
As currently drafted, R2 requires GOs and TOs to evaluate Disturbance records "since January 1, 2003," a time that will precede the effective date of this standard. A requirement cannot rely upon records that precede the effective date of a standard. As an example, PRC-005-1, which was approved in Order 693, became effective on June 11, 2007, does not require a Registered Entity to have maintenance records available for the period of time that preceded the effective date in order to calculate the next maintenance interval for a relay. CAN-0008 specifically states "CEAs are not to require registered entities to produce records of testing and maintenance activities conducted prior to June 18, 2007, because keeping such records was not mandatory at that time. Therefore, CEAs are only to require production of actual maintenance and testing records from June 18, 2007 forward." Oncor would hope the same applies across all Standards and Requirements.
No
See response to question #1.
No
See response to question #1.
No

Oncor agrees with the recommendation of the NERC PC (SCPS) and recommends if this has not been reviewed by NERC RISC, this may be an opportunity for the NERC Standard Committee (SC) to bring back to RISC for discussion in conjunction with the PSRPS technical document. If RISC and SC find the Standard should be developed, a clearer explanation as to what contingency the term "line out conditions" refers to should be included as this will determine the data source we use to generate our list of elements.

No

Please see response #1, #6 and #10

R1 criteria 4 states to identify the following element: "An Element identified in the most recent Planning Assessment where relay tripping occurred for a power swing during a Disturbance." In the statement above it is not clear whether the disturbance is actual or simulated. R4 should state Each Generator Owner and Transmission Owner shall implement each CAP developed pursuant to Requirement R3 if option 3 or option 4 are chosen, and update each CAP if actions or timetables change, until all actions are complete. There should be no CAP required if R3 option 2 is chosen and the application of power swing blocking must be applied to specific relay locations. Oncor agrees with the recommendation of the NERC PC (SCPS) and recommends if this has not been reviewed by NERC RISC, this may be an opportunity for the NERC Standard Committee (SC) to bring back to RISC for discussion in conjunction with the PSRPS technical document.

Individual

Glenn Pressler

CPS Energy

Group

Florida Municipal Power Agency

Frank Gaffney

No

As recognized by the SCPS, the standard is not needed and will result in a reduction of reliability to the bulk-power system (see report of footnote 1, Chapter 3, section titled "Need for a Standard"). FMPA strongly agrees with the SCPS that it is better for bulk-power system reliability to bias the "Art of Protection" to enable the power system to separate for unstable power swings than to bias the art of protection to prevent operation for stable power swings since it is very difficult, if not impossible, to distinguish stable from unstable power swings. We ought to enable the power system to gracefully degrade for unstable events rather than cause entire Interconnections to become unstable. We cannot with accuracy pre-determine where the separation points are or ought to be since we cannot know in advance where or what the cause of instability may occur. As such, having relays throughout the system that can cause separation as needed to prevent the entire Interconnection from going unstable is recommended. As such, and recognizing that we are directed to have a standard, the standard should not require PCs, RCs and TPs to identify that for every Element that meets the criteria of R1, something needs to be done (which is implied in R3). Rather, the PC, RC and TP ought to have discretion as to whether they want a potential issue resolved or not within R1. That is, the PC, RC and TP should have discretion as to whether to bias the performance towards separation for unstable power swings (graceful degradation for instability, but possibly contribute to cascading for stable power swings – although there is no evidence of the latter from past events), or bias the performance to prevent operation for stable power swings (which would have a tendency to cause blackouts to be greater in magnitude, but possibly reduce the risk of cascading for stable power swings, although there is no evidence of the latter), noting that there is no dependable way to distinguish between stable and unstable power swings. As such, the PC, RC and TP ought to be able to identify a subset of Elements that meet the criteria of R1 that would then be analyzed in R2 and R3. Note also that "Element" is the wrong term and "Facility" should be used. "Element" applies to both BES and non-BES (including distribution), Facilities is BES. Standards cannot be written to distribution.

No

Unless there is a requirement somewhere in the standards for Reliability Coordinators to perform stability analyses (there currently is not, SOLs/IROLs are studied by the TOP in accordance with the

RC's methodology); then, this requirement would cause all RCs to have to perform stability studies. Also, "corrective action plans" for protection systems will more likely be a planning horizon activity (e.g., changing out relays) and hence, the studies should be planning horizon studies, not operating horizon studies and the RC should not be included.

Yes

There is a significant issue with R2 in that it "requires" entities to have records before 1/1/2003. Entities had no knowledge of needing to retain such records (i.e., the cause of a relay trip as a stable power swing). Even if PRC-004 misoperations are the source of such data, there is no requirement to retain records for longer than 12 months (PRC-004 has a 12 month data retention in Section D1.4), and certainly not before June 18, 2007. The requirement should only be on a going forward basis, not going back. Note also that "Element" is the wrong term and "Facility" should be used. "Element" applies to both BES (including distribution) and non-BES, Facilities is BES. Standards cannot be written to distribution.

No

See response to Question 1, the TO/GO should only respond to those issued identified by the PC/TP and not all Facilities that meet the criteria of R1.

No

Since a standard is not needed in the first place, then, there should be no VRF above a Low. All requirements should be Planning Horizon and none in Operating Horizon.

Group

DTE Electric

Kathleen Black

No comment

Yes

No

It would seem that the GO and TO could need input from the PC, RC and TP to determine if the conditions are still credible, based on system studies.

No

Based on the criterion for R3, it appears that only impedance relays are in scope. What about other relay types? Specific criteria for all relay types should be provided along with examples on how to demonstrate a no trip response.

No comment

No

Paragraph four on Page 23 of 61 of the PSRPS Report states that current-only based protection is immune to operating during power swingw, but the Application to Generator Owners paragraph on page 23 of 25 of the draft standard implies that time overcurrent relays are subject to incorrect operation caused by stable power swings. Perhaps this could be clarified. Since relay engineers are typically not familiar with transient stability studies, it would be helpful if more examples were provided for specific generator relay types that would be prone to operate for power swings.

No comment

No comment

No comment

No comment

Individual

Karin Schweitzer

Texas Reliability Entity
Yes
Yes
A TOP may also provide an analyses in the Operations horizon that could identify other lines pursuant to the PSRSP technical document. Has the SDT considered the inclusion of TOP in the applicability? The requirement as written implies that both the identification and notification of Elements must both be accomplished in January of each year. Identification can happen anytime each year, but notification must occur annually by January 31 each year. Suggest "Each year, each Planning Coordinator, Reliability Coordinator, and Transmission Planner shall identify, and by January 31 of each calendar year, provide notification..."
Yes
The GO and TO are the appropriate responsible entities. The timeframe appears identified in Criteria 1 and 2 back to January 1, 2003 appears onerous. The Northeast Blackout should provide the impetus to look at power swings but may not need to be the basis for the timeframe. Suggestion is to leave date out; auditor discretion would tend to indicate "since last audit". Clarification is requested for Criteria 1 and 2 regarding the term "credible"; who is responsible for determining "credible" (is it tied to TPL-001-4)?
Yes
Suggest substituting "R1 and R2" for "R1 or R2" to avoid the possibility of confusion. As written, it could be construed that GOs and TOs can choose to address either R1 or R2 and not address both R1 and R2.
Yes
Yes
Section 1.2 – Evidence Retention: Language as written appears to be unnecessarily complicated. Suggest changing to: "Functional Entities shall retain evidence demonstrating compliance since the last audit or for three calendar years, whichever is longer."
Individual
Michael Moltane
ITC
Yes
In general we agree. However, the SDT should clarify what constitutes an island with regard to this standard as it's not a defined term. Should this standard pertain to lines which contain both generation and load, which when tripped form an island? We suggest not. Also, the term "credible" is unclear. If an event involves scenarios beyond TPL's "broad spectrum of System conditions" and "wide range of probably Contingencies", is it really credible? The example in Application Guideline involved a single bus outage, which is credible in TPL standards. However, a Disturbance may occur involving multiple contingencies but well beyond normal planning criteria and now that extreme event must be studied. If this approach is desired, then it leaves a gap for other extreme events to occur, just which we've had the good fortune not to have experienced yet. We suggest limiting the definition of "credible" into include those scenarios within the bounds of TPL-001-4.
Yes
We agree the GO and TO are the appropriate entities. However, we suggest removing the inclusion of events prior to the effective date of this standard.
No

In general we agree with this approach. However, we disagree with requiring compliance of one entity to be contingent on another entities agreement. We recommend changing to require notification instead of "agreement" in the fourth bullet and Criterion 1, second bullet.
No
R2 and R3 essentially leave an entity with 11 months to meet compliance. The Violation Severity Levels should be longer, considering the timeframe allowed to complete the task and the minimal risk to the BES.
Yes
The App Guide will be sufficient, considering the improvements mentioned in the webinar. In addition, we request more details regarding islanding scenarios and explanation of "credible" along the lines of our answer to Question 1.
No.
No
We are voting Negative primarily for two reasons: 1) the issues we raised need to be addressed to close some gaps and 2) we support the conclusion of SPCS in the PSRPS report that this standard "is not needed, and could result in unintended adverse impacts to Bulk-Power System reliability." As written, the standard only addresses distance and not overcurrent elements. This question was raised in the webinar and a clear answer was not given. The standard refers to "load-responsive" relays, which includes overcurrent, but does not provide criteria for evaluation in R3. Also, should the standard include time-delayed tripping elements, which are commonly ignored for swing tripping consideration? We also request examples for R3, fourth bullet, of scenarios which do not result in "dependable fault detection or dependable out-of-step tripping", perhaps in the App Guide. Specifically, we are concerned about load/swings with subsequent phase faults which result in time-delayed tripping when power swing blocking is enabled. Even the most modern SEL-400 relays with zero-setting OOS logic includes additional time delayed tripping for subsequent phase faults. For a standard around swings and stability, delayed fault clearing seems to counterproductive. Is this the scenario which could apply to R3, fourth bullet?
Individual
Thomas Standifur
Austin Energy
No
(1) City of Austin dba Austin Energy (AE) notes the following statement from the PSRPS technical document on page 20: "Based on its review of historical events, consideration of the trade-offs between dependability and security, and recognizing the indirect benefits of implementing the transmission relay loadability standard (PRC-023), the SPCS concludes that a NERC Reliability Standard to address relay performance during stable swings is not needed, and could result in unintended." AE believes more background work is necessary in justifying the creation of this standard before proceeding. (2) Further, AE disagrees with the R2 criteria of evaluating Disturbance records "since January 1, 2003." The criteria not only predate the enforcement date of this standard, it goes back to a time before any of the NERC Reliability Standards were enforceable.
Individual
Bill Temple

Northeast Utilities
No
We agree with a focused approach as outlined in the technical document. However, we have the following serious concerns with criteria in the requirements: 1. The term "credible event" should be clearly defined. The basis to determine a credible event is missing from the requirement and application guide. This basis should be provided in the standard requirement. 2. Why is the standard focused on SOL rather than IROL?The basis for specifying SOL is not supported by the example in the application guideline since the example did not show inter-area impact. 3. It is not clear in R1, criteria number 4 whether the assessment should include relay tripping or just stable power swing or both stable and unstable power swing. 4. In R2, it is unrealistic to require an entity to provide data on an Element that had tripped since 2003. There is no existing NERC continent-wide disturbance monitoring or misoperation standard that requires data be retained more than 12 months. We recommend that this requirement be removed from the standard or include only Elements that were tripped in the last calendar year.
Yes
Yes
See comment #4 under Question #1. In R2, it is unrealistic to require an entity to provide data on an Element that had tripped since 2003. There is no existing NERC continent-wide disturbance monitoring or misoperation standard that requires data be retained more than 12 months. We recommend that this requirement be removed from the standard or include only Elements that were tripped in the last calendar year.
No
The purpose of the standard is "to ensure that load responsive relay do not trip in response to stable power swing during non-fault condition." The last sentence of Background, Section 5 implies that protective relay while blocking for a stable power swing also allows for dependable operation for fault and unstable power swing. Bullet #4 in R3 indicates that the GO and TO must obtain agreement if dependable protection or dependable out-of-step tripping is not provided by a protection system that is immune to a stable power swing. Bullet #4 seems to imply that the purpose of the standard is to ensure blocking for a stable power swing and dependable tripping for unstable power swing. The drafting team needs to be very clear in the standard what the intention is. For instance, a line current differential scheme is immune to stable and unstable power swing and will provide dependable tripping for fault. The criteria as written implies that this type of scheme will need to be modified or an agreement will need to be obtained from the PC, RC and TP to deploy since it does not provide dependable out-of-step tripping.
Yes
No
1. In the Application Guidelines, the wording under Requirement 2 for "credible event" is very open-ended. 2. An example of how line differential protection would be treated with respect to Requirement 3 would be helpful. See the comment above in Question 4.
Yes
No
No
1. The annual frequency requirements listed in R1 & R2 are not necessary and that a less frequent (ie: Every 5 years) would be more appropriate. 2. Please provide more examples to help further illustrate the criteria in listed in R1. 3. Please differentiate between Stable and Unstable power swings.
Individual
Jonathan Meyer
Idaho Power Co.
No

No. R1 seems to be an acceptable approach for Planners to use. However, R2 is not acceptable. Having a dated requirement prior to the effective date of a Standard is not appropriate. While it may be reasonable to look at these earlier disturbances, making a Requirement of that review is not. This requirement should be removed or rewritten to require only the review of disturbances past the effective date of the Standard where tripping of Protection Systems during a stable power swing was a causal factor. In addition, the PSRPS technical document does not use the NERC Glossary term for Disturbances, yet the Standard does. The Glossary term is not specific which makes these criterion also non specific. Criterion similar to those in EOP-004 would seem to better identify the disturbances that are included in this Standard. M2 appears to require the utility to have evidence it did not know it needed to maintain. The PSRPS technical document suggests that the FERC directive to develop this standard may have been based on misinformation or a misunderstanding of the 2003 Northeast Blackout investigation report and furthermore suggests such a standard could result in unintended adverse impacts to the Bulk-Power System. Recommend NERC utilize the findings of the PSRPS technical document to obtain a stay of development of PRC-026-1 from FERC until FERC can develop a position based on the conclusions presented in the PSRSP document. If development of PRC-026-1 continues: I agree with the focused approach. R1.1 and R1.2 need to contain clarity about what constitutes a "line out condition" - does this mean N-1, N-2, N-X, transformers, etc? Concerning R1.3, who is the judge of whether an event is "credible"?

Yes

Yes, although I suggest adding the stipulation that the PC, RC, and TP must be in agreement about whether an Element meets the criteria in R1.

Yes

Yes if the Requirement is better written to address the comments of question 1. In addition, the GOP and TOP may also need to be included to fully identify disturbances. R2 requires entities to rely on records prior to the effective date of the standard - records the entities did not know they were required to keep for this purpose. Either strike R2 or change the wording such that R2 applies to Disturbances that have happened after the effective date of the standard

No

No. The Requirement as written is onerous to perform annually. Performing these checks during an initial implementation period for the standard is appropriate to ensure the relays will perform as designed (for tripping or blocking). After an initial assessment period, a re-check at longer intervals or triggered by system changes would also be appropriate. Further, as currently written, the R3 language requires one of the 4 bulleted items to be done, but the language on the 4th bullet implies that the first three be attempted first. If the first three are to be done prior to the 4th, should that bullet not be its own Requirement, such as an R3.1? The general approach is reasonable but an annual review is excessive. Bi-annually at the most and then by exception for any relay or system changes.

Yes

Yes

In the present form of R1-R4

No

The requirements need work before an implementation plan can be defined. It should be adjusted based on changes proposed in #4.

The PSRPS report and the SPS report no need for this Standard, stating that "operation of transmission line protection systems during stable power swings was not causal or contributory to any of these disturbances." This statement conflicts with the need for the Standard and causes added Compliance burden to entities without reason.

Individual

Patrick Farrell

Southern California Edison Company

Yes



Yes
Yes
No
Although we appreciate the drafting team's efforts, we believe that Requirement R3 is unnecessarily burdensome from a compliance perspective. We would suggest that the analyses of Elements be performed on an initial basis, and then when changes occur. An annual analyses of all the Elements assets is not efficient or warranted.
Yes
Yes
Yes
Individual
Russell Noble
Public Utility District No. 1 of Cowlitz County, WA
No
Cowlitz PUD agrees with the intent of standard PRC-026-1 (Standard) requirements R1 & R2 focused approach, but finds the current Standard draft creates a compliance difficulty. The Standard should clearly define the "specific criterion" which will be used to identify Elements, and compare the load-responsive protective relay characteristics to establish "credible" risk. The Standard lacks specificity as currently written. --(New Paragraph)-- This draft assumes incorrectly that an entity will have retained operational historical records since 2003. If such records do not exist, an entity will have no proof of having established a null or complete list which satisfies requirement R2. Further, there is no requirement to retain such operational records to facilitate future compliance. The CEA must either accept attestations, or require applicable entities to develop documentation for each section 4.2 applicable Element which establishes no credible risk of a trip during a [stable] power swing exists. Cowlitz PUD proposes the SDT identify specific documentation and establish an official listing, such as all pertinent RE and NERC disturbance studies/reports dated 2003 or later be used to identify past poorly performing Elements during a Disturbance. We are also unclear on how Elements might be identified purely from system modeling studies when strictly looking at Requirement R1 (ignoring R3 or other standard requirements outside of this Standard). Further, "credible" is a subjective term which does not establish a clear compliance line. It may be better to state "...actual system Disturbance where current system modeling continues to identify a repeat of the Disturbance possible under an n-3 event." Another possible method would be to tie "credible" to a probability of one in a thousand; this method would require probability model development. This is not to say that "credible" should not be used, but it will require extensive guidance in the RSAW of how the "credible" benchmark is established. In fairness, the benchmark should be established during Standard development to allow stakeholder review and comment.
No
Cowlitz PUD questions whether the Transmission Planner (TP) is nothing more than an extension of the Transmission Owner (TO), Generation Owner (GO), or Planning Coordinator (PC) registrations. Further, we believe the majority of those entities registered as a TP consider their TP footprint equal to their TO/GO/PC footprint. Therefore, it may be more appropriate for the TP to simply report Requirement R1 findings to the PC and RC. Finally, we believe it more efficient that a single entity be responsible to give notice to the TO and GO. Since every TO and GO must be under a Planning Coordinator and Reliability Coordinator, either the PC or the RC should be designated to send out the notice after their review is complete.

Yes
Provided the SDT finds a way to clearly establish the documentation from which the GO and TO will identify the Elements.
No comment at this time.
Yes
No
It is not clear how past events and Disturbance reports that must be considered in the identification of Elements will be archived and made available.
Yes
We believe this Standard will address a Reliability gap, but also feel that it can overlap into PRC-004. Load responsive relays that trip on a stable power swing should be addressed by PRC-004 as a Protection System Misoperation; subsequently after PRC-004 is satisfied, the affected element should be subject to PRC-026-1 until a repeat is demonstrated to be remote or nonexistent. However, a violation of PRC-004 should not automatically bleed into a violation of PRC-026-1.
Individual
Melissa Kurtz
US Army Corps of Engineers
Group
Colorado Springs Utilities
Kaleb Brimhall
Group
Puget Sound Energy
Eleanor Ewry
No
For systems that have not experienced a power swing that caused a trip or islanding condition, there is the burden of proving the negative to demonstrate compliance with the standard. It is recommended that Requirement R2 be rewritten in such a way that entities will not have to prove the negative. It is also recommended that the standard be revised to address the situation where historical data is not available as far back as 2003. We also request that a NERC definition be provided for what constitutes a stable power swing and what criteria can be applied to historical data to determine if a stable power swing has occurred.
Yes
Yes
Yes
While this approach seems reasonable, there is currently a lack of ability to model the load-responsive protective relays to determine whether a protection system is expected to trip in response to a stable power swing. While this capability is currently being implemented, it will not be completed by the proposed implementation date of this standard.
Yes
Yes
No
As noted in question 4, the modeling of protective relays needed to evaluate the system will not be implemented by the proposed implementation date for the standard.

As stated in the document entitled "Protection System Response to Power Swings" by PSRPS, a review of historical system disturbances determined that operation of transmission line protection systems during stable power swings was not causal or contributory to any of the disturbances reviewed. The final conclusion of PSRPS was that a NERC Reliability Standard is not needed to address relay performance due to stable power swings and could result in unintended adverse impacts to Bulk Power System reliability. In light of this conclusion, as well as the comments contained in this form, we have voted 'no' on this standard.
Individual
Anthony Jablonski
ReliabilityFirst
ReliabilityFirst offers the following comments for consideration. 1. Requirement R1 – To be consistent with other NERC Reliability Standards, ReliabilityFirst suggests reclassifying the “criteria” as “sub-parts” of the requirement. 2. Requirement R2 - R2 requires GOs and TOs to evaluate Disturbances “since January 1, 2003”. It appears that the intent of this requirement is to include Elements where actual system events caused a trip due to a known power swing and, by including the 2003 date, ensured that events associated with the 2003 Blackout were included. However, this may imply that events prior to 2003 need not be considered, especially in areas other than the Northeast where the blackout occurred. If an Element had a known trip for power swings associated with a Disturbance, they should be included. Therefore, ReliabilityFirst recommends the flowing for consideration for the two criteria: “1. An Element that has tripped since January 1, 2003 [(or known historical Element that tripped prior to January 1, 2003)], due to a power swing during an actual system Disturbance where the Disturbance(s) that caused the trip due to a power swing continues to be credible. 2. An Element that has formed the boundary of an island since January 1, 2003 [(or known historical Element that formed the boundary of an island prior to January 1, 2003)], during an actual system Disturbance where the Disturbance(s) that caused the islanding condition continues to be credible.” 3. Requirement R3 – ReliabilityFirst requests clarification on how the Criterion in Requirement R3 fits into the requirement. Is this criterion part of the requirement or is it additional information? If it is the later, ReliabilityFirst believes this guidance is already covered in the “Guidelines and Technical Basis” section and should be removed from the requirements. NERC Reliability Requirements should address “what” is required and not “how” an entity will comply.
Group
Bonneville Power Administration
Andrea Jessup
No
BPA agrees with the approach, with two exceptions. First, BPA feels more clarity is needed regarding which Elements are associated with System Operating Limits (SOLs), relevant to the Standard. Stability constraints can depend on the overall topology of the system, in which case nearly every Element in the power system would meet the criteria of item 2. For example, BPA may determine a stability constraint on WECC Path 66 due to poorly damped oscillations. Taking almost any 500 kV or 345 kV line out of service on the western side of WECC could change the value of this limit, in which case all of these Elements meet the criteria of item 2. BPA suggests the language be changed to: 2. An Element that has been shown to have a substantial effect on a System Operating Limit (SOL) that has been established based on stability constraints identified in system planning or operating

studies (including line-out conditions.) Secondly, BPA feels the Glossary definition of Disturbance lacks sufficient clarity as it relates to this and other existing Standards.
No
BPA feels the Standard needs to delineate which entity performs which role, and under which conditions. For example, the Reliability Coordinator (RC) only identifies the Elements tripped during islanding and disturbance, while the Planning Coordinator (PC) and Transmission Planner (TP) do so for long term planning.
Yes
Yes
BPA believes R3 should be modified for greater clarity and to allow for intentional power swing relays designed to be tripped in a controlled manner to protect the BES. Additionally, the wording in the fourth bullet appears to be inconsistent with the Rationale for R3.
Yes
No
BPA feels 12 months is insufficient time for the initial implementation.
Western Interconnection has many long lines and remote generation.
BPA feels the Glossary definition of Disturbance lacks sufficient clarity as it relates to this and other existing Standards. BPA also requests a descriptive title be used for the Criterion (e.g. Criterion for Swing Protection Analysis).
Individual
Joshua Andersen
Salt River Project
Yes
Yes
Yes
Yes
Yes
Yes
Yes
None
None
Salt River Project is concerned that system protection should not be "de-tuned" at the expense of the protection provided the Bulk Electric System for the sake of reliability.
Group
Arizona Public Service Co.
Janet Smith
Yes
While AZPS agrees with the focused approach, AZPS would like to ask the drafting team to consider revising R1 and R2. APS recommends that the drafting team require an initial identification and

notification of each Element that meets the criteria described in R1. A review of the assessment should not be required annually if there are no additions to the entity system meeting the criteria. It would be more practical to require a comprehensive review every five years. In addition, the standard should require that if Elements are added to the entity system that meet the criteria in R1, the applicable entity should provide updates within 90 days of the commissioning of a new Element. APS believes that the current draft requirement is administrative in nature and represents a reporting burden.

Yes

No

AZPS believes that the GO and TO are not the appropriate entities to identify the Elements that meet the criteria in R2. The criteria of R2 would be determined based on event analysis and the GO's and TO's have limited access to this information. Also, there are often joint participation projects which then include multiple owners. This would create confusion regarding who is supposed to complete the analysis. AZPS recommends that the RC be required to provide this information since they are necessarily involved in all significant system event analyses.

No

AZPS would recommend changing Protection System to load-responsive protective relays and define what type of relays qualifies as load-responsive protective relays. If the drafting team does not agree with defining load-responsive relays, they should specifically state the relay type (i.e. zone protection) rather than using the broader term Protection System.

No

APS suggests the timelines associated with the proposed VSL for Requirement 1 be adjusted to a longer time period if drafting team addresses the APS issue associated with the timing requirements on R1.

Yes

No

AZPS suggests the timeline for the implementation plan be increased to allow for two years for requirements one and two and requirements three and four be adjusted accordingly. APS believes significant effort will be required to identify relays that may qualify for inclusion.

APS recommends that the drafting team require an initial identification and notification of each Element that meets the criteria described R1. A review of the assessment should not be required yearly if there are no additions to the entity system meeting the criteria. It would be more practical to require a comprehensive review every five years. In addition, the standard should require that if Elements are added to the entity system that meet the criteria in R1, the applicable entity should provide updates within 90 days of the commissioning of a new Element. APS believes that the current draft requirement is administrative in nature and represents a reporting burden.

Individual

Kenneth A Goldsmith

Alliant Energy

No

In the Application Guide there is guidance provided for the determination of apparent impedance for Impedance Type Relays on page 23 of 25, under the "Application to Generator Owners" portion of the document. As noted in this section the process is complex. As such, we recommend adding a

detailed example of how the Transmission Planner should conduct this analysis on the behalf of the Generation Owner.

Group

Bureau of Reclamation

Erika Doot

Yes

Yes

No

The Bureau of Reclamation (Reclamation) believes that the Transmission Planner or Planning Coordinator would be in the best position to determine whether Disturbances continue to be credible. Therefore, Reclamation suggests that the Transmission Planner or Planning Coordinator would be in the best position to identify the Elements in R2. The Transmission Planner or Planning Coordinator should be required to notify the Transmission Owner or Generator Owner of which Elements meet the criteria so that the Transmission Owner or Generator Owner can perform the R3 analysis. Reclamation also suggests that the criteria be rephrased to require analysis of data from the previous year only. As written, R2 would require Transmission Owners and Generator Owners to re-analyze data going back to 2003 each year. Reclamation believes that the costs of re-analyzing this data would outweigh the benefits. Reclamation believes that NERC should develop a data request to develop a robust initial data set covering January 2003 to present.

Yes

Yes

Yes

Yes

Reclamation suggests that R2 be rephrased to only require analysis of data from the previous year. As written, R2 would require Transmission Owners and Generator Owners to re-analyze data going back to 2003 each year. Reclamation believes that the costs of re-analyzing this data would outweigh the benefits. Reclamation believes that NERC should develop a data request to develop a robust initial data set covering January 2003 to present.

## Consideration of Comments

### Project 2010-13.3 – Phase 3 of Relay Loadability: Stable Power Swings

The Stable Power Swings Drafting Team thanks all commenters who submitted comments on the standard. This standard was posted for a 45-day public comment period from April 25, 2014 through June 9, 2014. Stakeholders were asked to provide feedback on the standard and associated documents through a special electronic comment form. There were 70 sets of comments, including comments from approximately 181 different people from approximately 117 companies representing all 10 Industry Segments as shown in the table on the following pages.

All comments submitted may be reviewed in their original format on the standard's [project page](#).

If you feel that your comment has been overlooked, please let us know immediately. Our goal is to give every comment serious consideration in this process. If you feel there has been an error or omission, you can contact the Director of Standards, Valerie Agnew, at 404-446-2566 or at [valerie.agnew@nerc.net](mailto:valerie.agnew@nerc.net). In addition, there is a NERC Reliability Standards Appeals Process.<sup>1</sup>

### NERC Discussion on Proceeding(s) and Directives Regarding: Stable Power Swings

In the NOPR that led to Order No. 733, the Commission stated that the cascade during the August 2003 blackout was accelerated by zone 3/zone 2 relays that operated because they could not distinguish between a dynamic, but stable power swing and an actual fault. The Commission observed that PRC-023-1 does not address stable power swings, and pointed out that currently available protection applications and relays, such as pilot wire differential, phase comparison and blinder-blocking applications and relays, and impedance relays with non-circular operating characteristics, are demonstrably less susceptible to operating unnecessarily because of stable power swings. Given the availability of alternatives, the Commission stated that the use of protective relay systems that cannot differentiate between faults and stable power swings constitutes mis-coordination of the protection system and is inconsistent with entities' obligations under existing Reliability Standards. The Commission explained that a protective relay system that cannot refrain from operating under non-fault conditions because of a technological impediment is unable to achieve the performance required for Reliable Operation. Consequently, the Commission requested comments on whether it should direct the ERO to develop a new Reliability Standard or a modification to PRC-023-1 that requires the use of protective relay systems that can differentiate between faults and stable power swings and phases out protective relay systems that cannot meet this requirement.

NERC and other commenters urged the Commission to not direct modification of PRC-023-1 and instead allow NERC to determine the proper solution following technical analysis of the issue. Other

<sup>1</sup> The appeals process is in the Standard Processes Manual: [http://www.nerc.com/comm/SC/Documents/Appendix\\_3A\\_StandardsProcessesManual.pdf](http://www.nerc.com/comm/SC/Documents/Appendix_3A_StandardsProcessesManual.pdf)

commenters challenged the Commission's reasoning and assumptions for its proposed directive including challenging the validity of the assertion that stable power swings contributed to the cascade in the August 2003 blackout. Others argued that PRC-023-1 adequately covers the issue raised by the Commission. Despite the multiple avenues used to challenge the directive proposed by the Commission, the Commission ultimately directed NERC to create a new Reliability Standard that requires the use of protective relay systems that can differentiate between faults and stable power swings and, when necessary, phases out protective relay systems that cannot meet this requirement. The Commission stated that it found arguments that stable power swings did not contribute to the cascade in the August 2003 blackout to be unpersuasive.

Various organizations including NERC, APPA, EEI, NRECA, and TAPS sought rehearing of the Commission's directive. EEI made arguments that the Commission's directive was arbitrary and capricious and unsupported by the record. APPA asked the Commission to instead require NERC to examine whether and how operation of protective relays during stable power swings should be addressed through standards, or at minimum, clarify that it is leaving to NERC to determine the applicability of a requirement for relays to differentiate between faults and stable power swings and which relays must be phased out to achieve bulk power system reliability. NERC seeks clarification that it can use its industry technical experts to address the issue appropriately and asks for clarity as to whether the directive was intended to create an absolute requirement to highlight a concern that other approaches might satisfy.

The Commission maintained its position that not addressing stable power swings constitutes a gap in the current Reliability Standards and must be addressed. It did clarify in Order No. 733-A that NERC is able to use the standard development process to develop technical analysis and an approach to the Reliability Standard to meet the Commission's concern. The Commission also clarified that it did not direct the development of a Reliability Standard containing an absolute obligation to prevent protection relays from operating unnecessarily during stable power swings.

The EEI and NRECA jointly filed a timely motion and APPA/TAPS together filed a motion, in both instances, requesting clarification, or reconsideration of Order No. 733-A. In general, both motions assert the Commission based its directives on a faulty understanding of the Blackout Report<sup>2</sup> or an incorrect characterization of relay engineering. Both motions also reprise issues addressed in Order No. 733-A relating to the Commission exceeding its statutory authority by failing to give "due weight" to the technical expertise of the ERO and by giving overly prescriptive directives. Finally, EEI/NRECA seek clarification or reconsideration of language that they characterize as suggesting that the Commission expects 100 percent relay security and of the Commission's directive regarding generator relays. APPA and TAPS sought rehearing of Order No. 733-A. In summary, the Commission ruled, in Order No. 733-B, that the issues had been addressed in both Order Nos. 733 and 733-A and that further clarification is not necessary.

---

<sup>2</sup> <http://www.nerc.com/pa/rrm/ea/Pages/Blackout-August-2003.aspx>



In addition to the rehearing requests, NERC filed an informational filing to introduce and clarify certain aspects of the August 14, 2003 blackout investigation relative to operation of protective relays in response to stable power swings. NERC explained that the fourteen lines discussed in Order No. 733 did not trip due to stable power swings. NERC stated that ten of these lines tripped in response to the steady-state loadability issue addressed by Reliability Standard PRC-023, while the last four lines tripped in response to dynamic instability of the power system. Although the fourteen line trips by zone 2 and zone 3 relays discussed in the Blackout Report<sup>3</sup> did not occur as a result of stable power swings, the blackout investigation team did identify two transmission lines that tripped due to *protective relay operation in response to stable power swings*.

In August of 2013, the NERC System Protection and Control Subcommittee (SPCS) issued its report *Protection System Response to Power Swings, August 2013*<sup>4</sup> (“PSRPS Report”). In response to the FERC directive, NERC initiated this Project 2010-13.3 – Phase 3 of Relay Loadability: Stable Power Swings to address the issue of protection system performance during power swings. To support this effort, and in response to a request for research from the NERC Standards Committee, the SPCS, with support from the System Analysis and Modeling Subcommittee (SAMS), developed the PSRPS Report to promote understanding of the overall concepts related to the nature of power swings; the effects of power swings on protection system operation; techniques for detecting power swings and the limitations of those techniques; and methods for assessing the impact of power swings on protection system operation.

Based on its review of historical events, consideration of the trade-offs between dependability and security, and recognizing the indirect benefits of implementing the transmission relay loadability standard (PRC-023), the SPCS concluded that a NERC Reliability Standard to address relay performance during stable power swings is not needed, and could result in unintended adverse impacts to Bulk-Power System reliability. While the SPCS recommended that a Reliability Standard is not needed, the SPCS recognized the directive in Order No. 733 and the Standards Committee request for research to support Project 2010-13.3. Therefore, the SPCS provided recommendations for applicability and requirements that can be used if NERC chooses to develop a standard. The SPCS recommended that if a standard is developed, the most effective and efficient use of industry resources would be to limit applicability to protection systems on circuits where the potential for observing power swings has been demonstrated through system operating studies, transmission planning assessments, event analyses, and other studies, such as UFLS assessments, that have identified locations at which a system separation may occur.

Following the issuance of the PSRPS Report and prior to initiating standard development, NERC staff met with FERC staff to discuss the findings in the PSRPS Report in relation to its directive on creation of

---

<sup>3</sup> Ibid.

<sup>4</sup> NERC System Protection and Control Subcommittee, *Protection System Response to Power Swings*, August 2013: [http://www.nerc.com/comm/PC/System%20Protection%20and%20Control%20Subcommittee%20SPCS%2020/SPCS%20Power%20Swing%20Report\\_Final\\_20131015.pdf](http://www.nerc.com/comm/PC/System%20Protection%20and%20Control%20Subcommittee%20SPCS%2020/SPCS%20Power%20Swing%20Report_Final_20131015.pdf)

a stable power swings Reliability Standard. FERC staff acknowledged the work of the SPCS and agreed that it could be persuasive as technical support for the approach to the Reliability Standard to be developed. It was clear from this meeting that FERC staff was open to an approach designed by NERC and industry and that the expectation remained that the directive must be met. NERC staff proceeded with Project 2010-13.3 to design a Reliability Standard to meet the directive.

## Summary of Changes to the Standard

### Purpose Statement

The standard's purpose was revised from ensuring "relays do not trip" to "relays are expected to not trip" ... in response to stable power swings during non-Fault conditions.

### Applicability

The Reliability Coordinator and Transmission Planner were removed from the standard to address concerns about overlap and potential gaps when identifying Elements.

Applicability for the Generator Owner and Transmission Owner was augmented to refer to an appended "Attachment A" which describes load-responsive protective relays that are included in the standard and associated exclusions.

### Requirements

Requirement R1 was revised substantively to remove the Reliability Coordinator and Transmission Planner functions. The drafting team concurred that having the Planning Coordinator as the single source for identifying Elements prevents potential duplication of work and a possible gap should an entity believe another is making the identification and notification. The Requirement now allows a full calendar year to notify the respective Generator Owner and Transmission Owner of an identified Element. This was done to eliminate the burden of providing notification each January. The following describes the changes made to each of the original four criteria including the addition of a fifth criterion.

1. Added "angular" to clarify that this is not referring to other constraints such as voltage. Also replaced "Special Protection System (SPS)" with "Remedial Action Scheme (RAS)" to comport with expected changes to these NERC defined terms.
2. Clarified that criterion 2 applies only to "monitored" Elements of a System Operating Limit (SOL). Also, added "angular" to clarify that this is not referring to other constraints such as voltage.

3. Revised the “islanding” criterion to remove ambiguity about islands that formed during planning assessments. Islanding is now associated with an Element that forms the boundary of an island due to angular instability within an underfrequency load shedding (UFLS) assessment. Also, added “angular” to clarify that this is not referring to other constraints such as voltage.
4. Replaced the term “Disturbance” with the phrase “simulated disturbance.” because it generally refers to an actual and not simulated event. The lowercase term “disturbance” was considered to be consistent with the NERC TPL-001-4 Reliability Standard, but it was determined that its usage would continue to create questions so “simulated” was added. The phrase “stable or unstable” was inserted to clarify that both are applicable to power swings because the goal of the standard is to identify Elements susceptible to either.
5. This criterion was added as a mechanism to require the Planning Coordinator to continue identifying any Element that has been reported by a Generator Owner due to a stable or unstable power swing during an actual system Disturbance or by the Transmission Owner due to a stable or unstable power swing during an actual system Disturbance or islanding event. Reported Elements will continue to be identified by the Planning Coordinator until the Planning Coordinator determines the Element is no longer susceptible to power swings.

Requirement R2 was revised to remove the Generator Owner performance because the Generator Owner does not “island.” Also, the January 1, 2003 date was removed due to industry confusion and concern about compliance with such a date and how enforcement would be handled should an entity not have good records. In order to maintain continuity of actual Disturbances and to raise awareness of power swing and islanding events, the Transmission Owner is required to report the affected Element to its Planning Coordinator. The only timeframe assigned to the Requirement is the notice to the Planning Coordinator of an Element that tripped due to a stable or unstable power swing. There is no requirement to review the Protection System operation as such activities are addressed by other NERC Reliability Standards.

Requirement R3 is a new requirement created from the previous Requirement R2 specifically for the Generator Owner. In order to maintain continuity of actual Disturbances and to raise awareness of power swing events, the Generator Owner is required to report the affected Element to its Planning Coordinator. The only timeframe assigned to the Requirement is the notice to the Planning Coordinator of an Element that tripped due to a stable or unstable power swing. There is no requirement to review the Protection System operation as such activities are addressed by other NERC Reliability Standards.

Requirement R4 (previously R3) has been substantially rewritten to eliminate multiple and varying activities such as, demonstrate, develop, and obtain agreement. The Requirement was further simplified to reference PRC-026-1 – Attachment B which contains the criteria for evaluating load-responsive protective relays by the Generator Owner and Transmission Owner. The timing for evaluating load-responsive protective relays, initially, is 12 full calendar month. As identified Elements are reported year after year, the Generator Owner and Transmission Owner are only required to re-evaluate its load-responsive protective relays applied on the terminals of the identified Element where

the previous evaluation had not been performed in the last three calendar years. This reduced the burden to the entities over Draft 1. Note that the Implementation Plan period for Requirement R4 is 336 calendar months.

Requirement R5 was added to address the requirement for developing a Corrective Action Plan (CAP) that was contained in the previous Draft 1, Requirement R3.

Requirement R6 was previously R4 and only received comportsing updates due to numbering changes.

#### PRC-026-1 – Attachment A

The PRC-026-1 – Attachment A was added to the standard due to reduce stakeholder confusion about what load-responsive protective relays are in scope and to provide specific exclusions. The attachment is referenced in the Applicability section of the standard.

#### PRC-026-1 – Attachment B

The PRC-026-1 – Attachment B was added to the standard to remove the “Criteria” for evaluating load-responsive protective relays from within the Requirement itself and provide it in an attachment for referencing by Requirement R4. Among other things, the criteria found in the attachment received these modifications:

1. The sending and receiving voltages were changed to 0.7 to 1.0 from 0 to 1.0 per unit. This increases the lens characteristic that the impedance characteristic (e.g., zone 2) must be completely contained within (Attachment B). It was determined that using the 0.7 per unit is not in conflict with other NERC Reliability Standards or accepted industry practice for setting protective relays.
2. In developing the lens characteristic formed in the impedance (R-X) plane that connects the endpoints of the total system impedance, the criteria now requires the “parallel transfer impedance” to be removed.
3. Although previously addressed within the standards’ Application Guidelines, criteria as to whether the transient or sub-transient may be used are now specified. The criteria are further defined as the “saturated (transient or sub-transient) reactance. The option to use either transient or sub-transient is provided to entities because either will provide a lens characteristic that is sufficiently conservative to determine the relay’s susceptibility to tripping in response to a stable power swing. Also, providing this option reduces the burden on entities from changing which value it uses when it is already using one or the other preset in software applications. Saturated reactances are specified since they result in lower system impedances. Most notable, this criterion now requires the “parallel transfer impedance” to be removed when using the criteria to determine the relay’s susceptibility to tripping in response to a stable power swing.

4. The PRC-026-1 – Attachment B now includes an additional Criteria B which provides criteria for overcurrent-based protective relays. Like the original Criteria A for impedance-based relays, it uses the 120 degree system separation angle, all Elements in service, and saturated (transient or sub-transient) reactance. This criterion also requires the “parallel transfer impedance” to be removed.

1. Do you agree with the focused approach using the criteria (see R1 & R2) which came from recommendations in the PSRPS technical document (pg. 21 of 61)? If not, please explain why or why not (e.g., the approach should be more narrow or more broad, and if so, the basis for a different approach). ..... 21
2. Do you agree that the Planning Coordinator, Reliability Coordinator, and Transmission Planner are the appropriate entities to identify the Elements that meet the criteria in Requirement R1? If not, please explain why an entity is not appropriate and/or suggest an alternative that should identify the Elements according to the criteria ..... 62
3. Do you agree that the Generator Owner and Transmission Owner are the appropriate entities to identify the Elements that meet the criteria in Requirement R2? If not, please explain why an entity is not appropriate and/or suggest an alternative that should identify the Elements according to the criteria ..... 75
4. Do you agree with the approach in Requirement R3 to ensure that load-responsive protective relays do not trip in response to stable power swings during non-Fault conditions for an identified Element? If not, please explain ..... 91
5. Do you agree with the proposed Violation Risk Factors (VRF) and Violation Severity Levels (VSL) for the proposed requirements? If not, please provide a basis for revising a VRF and/or what would improve the clarity of the VSLs ..... 116
6. Does PRC-026-1, Application Guidelines and Technical Basis provide sufficient guidance, basis for approach, and examples to support performance of the requirements? If not, please provide specific detail that would improve the Guidelines and Technical Basis ..... 124
7. Do you agree with implementation period of the proposed standard based on the considerations listed in the Implementation Plan? If not, please provide a justification for changing the proposed implementation period..... 137
8. If you are aware of any conflicts between the proposed standard and any regulatory function, rule, order, tariff, rate schedule, legislative requirement, or agreement please identify the conflict here ..... 150
9. If you are aware of the need for a regional variance or business practice that should be considered with this phase of the project, please identify it here: ..... 154
10. If you have any other comments on this Standard that you haven't already mentioned above, please provide them here ..... 157

The industry segments are:

- 1 — Transmission Owners
- 2 — RTOs, ISOs
- 3 — Load-Serving Entities
- 4 — Transmission-Dependent Utilities
- 5 — Electric Generators
- 6 — Electricity Brokers, Aggregators, and Marketers
- 7 — Large Electricity End Users
- 8 — Small Electricity End Users
- 9 — Federal, State, Provincial Regulatory or other Government Entities
- 10 — Regional Reliability Organizations, Regional Entities

Group/Individual		Commenter	Organization	Registered Ballot Body Segment										
				1	2	3	4	5	6	7	8	9	10	
1.	Group	Guy Zito	Northeast Power Coordinating Council											X
Additional Member		Additional Organization	Region	Segment Selection										
1.	Alan Adamson	New York State Reliability Council, LLC	NPCC	10										
2.	David Burke	Orange and Rockland Utilities Inc.	NPCC	3										
3.	Greg Campoli	New York Independent System Operator	NPCC	2										
4.	Sylvain Clermont	Hydro-Québec TransÉnergie	NPCC	1										
5.	Wayne Sipperly	New York Power Authority	NPCC	5										
6.	Gerry Dunbar	Northeast Power Coordinating Council	NPCC	10										
7.	Mike Garton	Dominion Resources Services, Inc.	NPCC	5										
8.	Matt Goldberg	ISO - New England	NPCC	2										
9.	Michael Jones	National Grid	NPCC	1										
10.	Mark Kenny	Northeast Utilities	NPCC	1										
11.	Christina Koncz	PSEG Power LLC	NPCC	5										

Group/Individual	Commenter	Organization	Registered Ballot Body Segment										
			1	2	3	4	5	6	7	8	9	10	
12. Helen Lainis	Independent Electricity System Operator	NPCC 2											
13. Alan MacNaughton	New Brunswick Power Corporation	NPCC 9											
14. Bruce Metruck	New York Power Authority	NPCC 6											
15. Ben Wu	Orange and Rockland Utilities Inc.	NPCC 1											
16. Lee Pedowicz	Northeast Power Coordinating Council	NPCC 10											
17. Robert Pellegrini	The United Illuminating Company	NPCC 1											
18. Si Truc Phan	Hydro-Québec TransÉnergie	NPCC 1											
19. David Ramkalawan	Ontario Power Generation, Inc.	NPCC 5											
20. Brian Robinson	Utility Services	NPCC 8											
21. Ayesha Sabouba	Hydro One Networks Inc.	NPCC 1											
22. Brian Shanahan	National Grid	NPCC 1											
2.	Group	Sandra Shaffer	PacifiCorp						X				
N/A													
3.	Group	Joe DePoorter	MRO NERC Standards Review Forum	X	X	X	X	X	X				
	<b>Additional Member</b>	<b>Additional Organization</b>	<b>Region</b>	<b>Segment Selection</b>									
1.	Alice Ireland	Xcel Energy	MRO	1, 3, 5, 6									
2.	Chuck Wicklund	Otter Tail Power		1, 3, 5									
3.	Dan Inman	Minnkota Power Cooperative	MRO	1, 3, 5, 6									
4.	Dave Rudolph	Basin Electric Power Cooperative	MRO	1, 3, 5, 6									
5.	Kayleigh Wilkerson	Lincoln Electric System	MRO	1, 3, 5, 6									
6.	Jodi Jensen	WAPA	MRO	1, 6									
7.	Joe DePoorter	Madison Gas & Electric	MRO	3, 4, 5, 6									
8.	Ken Goldsmith	Alliant Energy	MRO	4									
9.	Mahmood Safi	Omaha Public Power District	MRO	1, 3, 5, 6									
10.	Marie Knox	MISO	MRO	2									
11.	Mike Brytrowski	Great River Energy	MRO	1, 3, 5, 6									
12.	Randi Nyholm	Minnesota Power	MRO	1, 6									
13.	Scott Nickels	Rochester Public Utilities	MRO	4									
14.	Terry Harbour	MidAmerican	MRO	1, 3, 5, 6									



Group/Individual	Commenter	Organization	Registered Ballot Body Segment											
			1	2	3	4	5	6	7	8	9	10		
15. Tom Breene	Wisconsin Public Service	MRO 3, 4, 5, 6												
16. Tony Eddleman	Nebraska Public Power District	MRO 1, 3, 5												
4. Group	Paul Haase	Seattle City Light	X		X	X	X	X						
<b>Additional Member Additional Organization Region Segment Selection</b>														
1. Pawel Krupa	Seattle City Light	WECC 1												
2. Dana Wheelock	Seattle City light	WECC 3												
3. Hao Li	Seattle City Light	WECC 4												
4. Mike Haynes	Seattle City Light	WECC 5												
5. Dennis Sismaet	Seattle City Light	WECC 6												
5. Group	Joe Tarantino	SMUD/BANC	X		X	X	X	X						
<b>Additional Member Additional Organization Region Segment Selection</b>														
1. Kevin Smith	BANC	WECC 1												
6. Group	Dennis Chastain	Tennessee Valley Authority	X		X		X	X						
<b>Additional Member Additional Organization Region Segment Selection</b>														
1. DeWayne Scott		SERC 1												
2. Ian Grant		SERC 3												
3. David Thompson		SERC 5												
4. Marjorie Parsons		SERC 6												
7. Group	Robert Rhodes	SPP Standards Review Group		X										
<b>Additional Member Additional Organization Region Segment Selection</b>														
1. Bud Averill	Grand River Dam Authority	SPP 1												
2. Mo Awad	Westar Energy	SPP 1, 3, 5, 6												
3. Derek Brown	Westar Energy	SPP 1, 3, 5, 6												
4. Karl Diekevers	Nebraska Public Power District	MRO 1, 3, 5												
5. Don Hargrove	Oklahoma Gas & Electric	SPP 1, 3, 5												
6. Jonathan Hayes	Southwest Power Pool	SPP 2												
7. Brian Holmes	Nebraska Public Power District	MRO 1, 3, 5												
8. Stephanie Johnson	Westar Energy	SPP 1, 3, 5, 6												

Group/Individual		Commenter	Organization	Registered Ballot Body Segment									
				1	2	3	4	5	6	7	8	9	10
9.	Bo Jones	Westar Energy	SPP	1, 3, 5, 6									
10.	Mike Kidwell	Empire District Electric	SPP	1, 3, 5									
11.	Tiffany Lake	Westar Energy	SPP	1, 3, 5, 6									
12.	James Nail	City of Independence, MO	SPP	3									
8.	Group	Wayne Johnson	Southern Company: Southern Company Services, Inc.; Alabama Power Company; Georgia Power Company; Gulf Power Company; Mississippi Power Company; Southern Company Generation; Southern Company Generation and Energy Marketing		X		X		X	X			
N/A													
9.	Group	Greg Campoli	ISO RTO Council Standards Review Committee			X							
<b>Additional Member Additional Organization Region Segment Selection</b>													
1.	Stephanie Monzon	PJM	RFC	2									
2.	Charles Yeung	SPP	SPP	2									
3.	Lori Spence	MISO	MRO	2									
4.	Cheryl Moseley	ERCOT	ERCOT	2									
5.	Matt Goldberg	ISONE	NPCC	2									
6.	Ben Li	IESO	NPCC	2									
7.	Ali Miremadi	CAISO	WECC	2									
10.	Group	Mike Garton	Dominion		X		X		X	X			
<b>Additional Member Additional Organization Region Segment Selection</b>													
1.	Louis Slade	Dominion	RFC	5, 6									
2.	Randi Heise	Dominion	NPCC	6									
3.	Connie Lowe	Dominion	SERC	5, 6									
4.	Larry Nash	Dominion	SERC	1, 3									
5.	Chip Humphrey	Dominion	SERC	5									
6.	Jeffrey Bailey	Dominion	NPCC	5									

Group/Individual		Commenter	Organization	Registered Ballot Body Segment									
				1	2	3	4	5	6	7	8	9	10
11.	Group	Jason Marshall	ACES Standards Collaborators						X				
<b>Additional Member</b>		<b>Additional Organization</b>		<b>Region</b>	<b>Segment Selection</b>								
1.	Shari Heino	Brazos Electric Power Cooperative	ERCOT	1, 5									
2.	Mark Ringhausen	Old Dominion Electric Cooperative	RFC	3, 4									
3.	Scott Brame	North Carolina Electric Membership Corporation	SERC	1, 3, 4, 5									
4.	Mike Brytowski	Great River Energy	MRO	1, 3, 5, 6									
5.	Brian Hobbs	Western Farmers Electric Cooperative	SPP	1, 5									
6.	Bill Hutchison	Southern Illinois Power Cooperative	SERC	1									
7.	Bernard Johnson	Oglethorpe Power Cooperative	SERC	5									
12.	Group	Richard Hoag	FirstEnergy Corp.	X		X	X	X	X				
<b>Additional Member</b>		<b>Additional Organization</b>		<b>Region</b>	<b>Segment Selection</b>								
1.	William Smith	FirstEnergy Corp	RFC	1									
2.	Cindy Stewart	FirstEnergy Corp	RFC	3									
3.	Doug Hohlbaugh	Ohio Edison	RFC	4									
4.	Ken Dresner	FirstEnergy Solutions	RFC	5									
5.	Kevin Querry	FirstEnergy Solutions	RFC	6									
6.	Richard Hoag	FirstEnergy Corp	RFC	NA									
7.	Brian Orians	FirstEnergy Solutions	RFC	NA									
8.	Rusty Loy	FirstEnergy Solutions	RFC	NA									
9.	Dave Barber	FirstEnergy Corp	RFC	NA									
13.	Group	Mike O'Neil	Florida Power & Light	X									
N/A													
14.	Group	Brent Ingebrigtsen	PPL NERC Registered Affiliates	X		X		X	X				
<b>Additional Member</b>		<b>Additional Organization</b>		<b>Region</b>	<b>Segment Selection</b>								
1.	Charlie Freibert	LG&E and KU Energy, LLC	SERC	3									
2.	Brenda Truhe	PPL Electric Utilities Corporation	RFC	1									
3.	Annette Bannon	PPL Generation, LLC	RFC	5									
4.		PPL Susquehanna, LLC	RFC	5									

Group/Individual	Commenter	Organization	Registered Ballot Body Segment																	
			1	2	3	4	5	6	7	8	9	10								
5.		PPL Montana, LLC	WECC	5																
6.	Elizabeth Davis	PPL EnergyPlus, LLC	MRO	6																
7.			NPCC	6																
8.			RFC	6																
9.			SERC	6																
10.			SPP	6																
11.			WECC	6																
15.	Group	Michael Lowman	Duke Energy		X		X		X	X										
<b>Additional Member Additional Organization Region Segment Selection</b>																				
1.	Doug Hils		RFC	1																
2.	Lee Schuster		FRCC	3																
3.	Dale Goodwine		SERC	5																
4.	Greg Cecil		RFC	6																
16.	Group	Patricia Robertson	BC Hydro		X															
<b>Additional Member Additional Organization Region Segment Selection</b>																				
1.	Venkataramakrishnan Vinnakota	BC Hydro	WECC	2																
2.	Pat G. Harrington	BC Hydro	WECC	3																
3.	Clement Ma	BC Hydro	WECC	5																
17.	Group	Tom McElhinney	JEA		X		X		X	X										
<b>Additional Member Additional Organization Region Segment Selection</b>																				
1.	Ted Hobson		FRCC	1																
2.	Garry Baker		FRCC	3																
3.	John Babik		FRCC	5																
18.	Group	Frank Gaffney	Florida Municipal Power Agency		X		X	X	X	X										
<b>Additional Member Additional Organization Region Segment Selection</b>																				
1.	Tim Beyrle	City of New Smyrna Beach	FRCC	4																
2.	Jim Howard	Lakeland Electric	FRCC	3																
3.	Greg Woessner	Kissimee Utility Authority	FRCC	3																

Group/Individual		Commenter		Organization		Registered Ballot Body Segment									
						1	2	3	4	5	6	7	8	9	10
4.	Lynne Mila	City of Clewiston	FRCC	3											
5.	Cairo Vanegas	Fort Pierce Utility Authority	FRCC	4											
6.	Randy Hahn	Ocala Utility Services	FRCC	3											
7.	Stanley Rzad	Keys Energy Services	FRCC	1											
8.	Don Cuevas	Beaches Energy Services	FRCC	1											
9.	Mark Schultz	City of Green Cove Springs	FRCC	3											
19.	Group	Kathleen Black	DTE Electric				X	X	X						
<b>Additional Member</b>		<b>Additional Organization</b>		<b>Region</b>	<b>Segment Selection</b>										
1.	Kent Kujala	NERC Compliance		RFC	3										
2.	Daniel Herring	NERC Training & Standards Development		RFC	4										
3.	Mark Stefaniac	Regulated Marketing		RFC	5										
4.	David Szulczewski	DO SEE Relay Engineering													
20.	Group	Kaleb Brimhall	Colorado Springs Utilities		X		X		X	X					
N/A															
21.	Group	Eleanor Ewry	Puget Sound Energy		X				X						
<b>Additional Member</b>		<b>Additional Organization</b>		<b>Region</b>	<b>Segment Selection</b>										
1.	Denise Lietz	Puget Sound Energy		WECC	1										
2.	Lynda Kupfer	Puget Sound Energy		WECC	5										
3.	Mariah Kennedy	Puget Sound Energy		WECC	3										
22.	Group	Andrea Jessup	Bonneville Power Administration		X		X		X	X					
<b>Additional Member</b>		<b>Additional Organization</b>		<b>Region</b>	<b>Segment Selection</b>										
1.	Jim Burns	Technical Operations		WECC	1										
2.	Jim Gronquist	Transmission Planning		WECC	1										
23.	Group	Janet Smith	Arizona Public Service Co.		X		X		X	X					
N/A															
24.	Group	Erika Doot	Bureau of Reclamation		X				X						
<b>Additional Member</b>		<b>Additional Organization</b>		<b>Region</b>	<b>Segment Selection</b>										
1.	Rick Jackson			WECC	1										

Group/Individual		Commenter	Organization	Registered Ballot Body Segment									
				1	2	3	4	5	6	7	8	9	10
25.	Individual	Steve Wickel	CHPD - Public Utility District No. 1 of Chelan County	X		X		X					
26.	Individual	Rick Terrill	Luminant Generation Company LLC					X					
27.	Individual	Michelle R. D'Antuono	Ingleside Cogeneration LP					X					
28.	Individual	Venona Greaff	Occidental Chemical Corporation							X			
29.	Individual	John Seelke	Public Service Enterprise Group	X		X		X	X				
30.	Individual	Jared Shakespeare	Peak Reliability	X									
31.	Individual	Daniel Duff	Liberty Electric Power					X					
32.	Individual	Mauricio Guardado	Los Angeles Department of Water and Power	X		X		X	X				
33.	Individual	Brenda Hampton	Luminant Energy Company, LLC						X				
34.	Individual	Ayesha Sabouba	Hydro One	X		X							
35.	Individual	Frederic R Plett	Massachusetts Attorney General								X		
36.	Individual	Rob Robertson	First Wind					X					
37.	Individual	Ronnie C. Hoeinghaus	City of Garland	X		X							
38.	Individual	Terry Harbour	MidAmerican Energy Company	X									
39.	Individual	Kayleigh Wilkerson	Lincoln Electric System	X		X		X	X				
40.	Individual	Thomas Foltz	American Electric Power	X		X		X	X				
41.	Individual	Chris de Graffenried	Consolidated Edison, Inc.	X		X		X	X				
42.	Individual	Cheryl Moseley	Electric Reliability Council of Texas, Inc.		X								
43.	Individual	Amy Casuscelli	Xcel Energy	X		X		X	X				
44.	Individual	Andrew Z. Pusztai	American Transmission Company, LLC	X									
45.	Individual	Jo-Anne Ross	Manitoba Hydro	X		X		X	X				
46.	Individual	Mark Wilson	Independent Electricity System Operator		X								

Group/Individual		Commenter	Organization	Registered Ballot Body Segment									
				1	2	3	4	5	6	7	8	9	10
47.	Individual	David Kiguel	David Kiguel								X		
48.	Individual	Richard Vine	California ISO		X								
49.	Individual	Chris Mattson	Tacoma Power	X		X	X	X	X				
50.	Individual	David Jendras	Ameren	X		X		X	X				
51.	Individual	Scott Langston	City of Tallahassee	X									
52.	Individual	Bob Thomas	Illinois Municipal Electric Agency				X						
53.	Individual	Bill Fowler	City of Tallahassee			X							
54.	Individual	John Pearson	ISO New England		X								
55.	Individual	Chris Scanlon	Exelon	X		X	X	X	X				
56.	Individual	Shivaz Chopra	New York Power Authority	X		X		X	X			X	
57.	Individual	Roger Dufresne	Hydro-Québec Production					X					
58.	Individual	Gul Khan	Oncor Electric Delivery LLC	X									
59.	Individual	Glenn Pressler	CPS Energy	X		X		X					
60.	Individual	Karin Schweitzer	Texas Reliability Entity										X
61.	Individual	Michael Moltane	ITC	X									
62.	Individual	Thomas Standifur	Austin Energy	X		X		X					
63.	Individual	Bill Temple	Northeast Utilities	X									
64.	Individual	Jonathan Meyer	Idaho Power Co.	X									
65.	Individual	Patrick Farrell	Southern California Edison Company	X		X		X	X				
66.	Individual	Russell Noble	Public Utility District No. 1 of Cowlitz County, WA			X	X	X					
67.	Individual	Melissa Kurtz	US Army Corps of Engineers					X					
68.	Individual	Anthony Jablonski	ReliabilityFirst										X
69.	Individual	Joshua Andersen	Salt River Project	X		X		X	X				

Group/Individual		Commenter	Organization	Registered Ballot Body Segment									
				1	2	3	4	5	6	7	8	9	10
70.	Individual	Kenneth A Goldsmith	Alliant Energy				X						
71.	Individual	David Dockery	Associated Electric Cooperative, Inc.	X		X		X					



If you support the comments submitted by another entity and would like to indicate you agree with their comments, please select "agree" below and enter the entity's name in the comment section (please provide the name of the organization, trade association, group, or committee, rather than the name of the individual submitter).

Summary Consideration: The drafting team appreciates the entities below supporting the comments of others. Having single sets of comments with documented support greatly improves the efficiency of the standard drafting team (SDT). This format also ensures the drafting team has a clearer picture of the number of stakeholders supporting the same concerns or suggestions as the case may be.

Organization	Agree	Supporting Comments of "Entity Name"
Ameren	Agree	Public Service Enterprise Group (PSEG)
City of Garland	Agree	Public Service Enterprise Group - comments submitted by John Seelke
City of Tallahassee	Agree	FMPA
City of Tallahassee	Agree	FMPA
Colorado Springs Utilities	Agree	Public Service Enterprise Group and Florida Municipal Power Agency
CPS Energy	Agree	FMPA and PSEG
First Wind	Agree	PSEG Fossil, T.J. Kucey
Hydro One	Agree	NPCC-RSC
Hydro-Québec Production	Agree	NPCC and Hydro-Québec TransÉnergie

Organization	Agree	Supporting Comments of "Entity Name"
Illinois Municipal Electric Agency	Agree	Florida Municipal Power Agency, and Public Service Enterprise Group
JEA	Agree	FMPA
Luminant Energy Company, LLC	Agree	Luminant Generation Company, LLC (Rick Terrill)
New York Power Authority		NPCC RSC Committee
Occidental Chemical Corporation	Agree	Ingleside Cogeneration, LP
Seattle City Light		Sacramento Municipal Utility District (SMUD)
Tacoma Power		PSEG
US Army Corps of Engineers	Agree	MRO NSRF
Xcel Energy	Agree	Public Service Enterprise Group (PSEG)

1. Do you agree with the focused approach using the criteria (see R1 & R2) which came from recommendations in the PSRPS technical document (pg. 21 of 61)? If not, please explain why or why not (e.g., the approach should be more narrow or more broad, and if so, the basis for a different approach).

Summary Consideration: More than half of the 177 commenter disagreed with various aspects of the approach to the standard. The following lists the chief concerns that resulted in changes to the standard and those that did not.

Comments that resulted in a change to the standard:

There were 17 comments from 58 individuals that were concerned about the initial burden of evaluating load-responsive protective relays. To address this, the drafting team increased the Implementation Plan to 36 calendar months for Requirement R4 to provide for the initial influx of identified Elements under Requirement R1. The evaluation of relays under Requirement R4 (previously R3) is to be performed “within 12 full calendar months of receiving notification of an Element ... where the evaluation has not been performed in the last three calendar years.” The Implementation Plan provides an initial 36 calendar months from approval. Ten comments from 39 stakeholders were concerned about how the term “credible” would be interpreted. The term “credible” was removed from the standard. Requirement R1, Criterion 3 was clarified by framing the criterion in the present tense to refer to current assessment(s). The term “credible” was also removed from the previous Requirement R2 (and new R3) because the required performance should only refer to only current actual events.

Four significant issues were raised in Requirement R1 and its Criterion. First, there were five comments from 36 individuals that requested clarity as to what “stability constraint” meant. To clarify this issue the term “angular” was added to “stability constraint” to clarify the intent in Requirement R1, both Criterion 1 and 2. Second, there were five comments from 38 stakeholders questioning if “power swings” meant both “stable” and “unstable” power swings. Requirement R1 – Criterion 4, Requirement R2 – Criterion 1, and the new Requirement R3 – Criterion 1, were clarified by adding both “stable and unstable” to the power swings language. Both stable and unstable power swings determine whether an Element will be identified as being affected by a power swing. Four comments supported by 13 individuals believed the term “associated” was not clear; therefore, the term “associated” was removed and the criteria was clarified that the Element is the “monitored” Element. Last, there were three comments from 11 stakeholders that were concerned about how to apply Requirement R1, Criterion 3. Because of this, Requirement R1, Criterion 3 was revised include island boundaries due to angular instability within an underfrequency load shedding (UFLS) assessment. Additionally, the Generator Owner function was moved from Requirement R2 to the new Requirement R3 in order to remove the “islanding” criteria for Generator Owners.

Comments that did not result in a change to the standard:

There were 21 comments from 58 stakeholders for varying reasons that a standard was not necessary with the primary reason being based on the conclusions of the technical report by the NERC System Protection and Control Subcommittee called *Protection System Response to Power Swings*, August 2013 (PSRPS Report). To address this concern and the need for a standard, the drafting team prepared information found at the beginning

of this document called, “NERC Discussion on Proceeding(s) and Directives Regarding: Stable Power Swings” for a complete background. The drafting team understands that NERC staff re-engaged FERC staff following the completion of the PSRPS Report and that the Commission still desired NERC to pursue its work to meet the directive. However, FERC staff was open to an approach designed by NERC. NERC staff has informally received positive feedback on the narrow approach to address the regulatory directive. The directive itself was challenged by commenters prior to the issuance of Order No. 733 and was already the subject of multiple rehearing requests in the Order No. 733-A and Order No. 733-B proceedings. Similar arguments to the conclusions of the NERC System Protection and Control Subcommittee were advanced in these FERC proceedings. Five comments by 34 individuals questioned the use of a System Operating Limit (SOL) in Requirement R1, Criterion 2 to determine Elements that needed evaluation because they were not necessarily associated with wide-area problems. The drafting team contends that not only SOLs that have been shown to expose a widespread area to instability, uncontrolled separation(s) or cascading outages should be considered. Identified localized instability issues also point to Elements that should reduce the likelihood of tripping for stable power swings. There were four comments by 18 individual that believe the standard required the inclusion of protective relay models. The standard does not require the inclusion of relay models. Requirement R1 – Criterion 4 is not requiring a study, but the identification of any Element that was observed as tripping in the most recent Planning Assessment.

Organization	Yes or No	Question 1 Comment
Northeast Power Coordinating Council	No	<p>We agree with a focused approach as outlined in the technical document. However, we have the following serious concerns with criteria in the requirements:</p> <p>1. The term “credible event” should be clearly defined. The basis to determine a credible event is missing from the requirement and application guide. This basis should be provided in the standard requirement.</p> <p><i>Response: The term “credible” has been removed from the standard. The drafting team clarified Requirement R1, Criterion 3 by framing the criterion in the present tense to refer to current assessment(s). The term “credible” was removed from the previous Requirement R2 (and new R3) because the required performance refers to only current actual events. Change made.</i></p> <p>2. Why is the standard focused on SOL rather than IROL? The basis for specifying SOL is not supported by the example in the application guideline since the example did not show inter-area impact.</p> <p><i>Response: Several commenters questioned the use of a System Operating Limit (SOL) to determine Elements that needed evaluation because they were not necessarily associated with wide-area problems.</i></p>

Organization	Yes or No	Question 1 Comment
		<p>The drafting team contends that not only SOLs that have been shown to expose a widespread area to instability, uncontrolled separation(s) or cascading outages should be considered. Identified localized instability issues also point to Elements that should reduce the likelihood of tripping for stable power swings. No change made.</p> <p>3. It is not clear in R1, criteria number 4 whether the assessment should include relay tripping or just stable power swing or both stable and unstable power swing.</p> <p>Response: Requirement R1 – Criterion 4, Requirement R2 – Criterion 1, and the new Requirement R3 – Criterion 1, were clarified by adding both “stable and unstable” power swings. Both stable and unstable power swings determine whether an Element will be identified as experiencing a power swing. Change made.</p> <p>4. In R2, it is unrealistic to require an entity to provide data on an Element that had tripped since 2003. There is no existing NERC continent-wide disturbance monitoring or misoperation standard that requires data be retained more than 12 months. We recommend that this requirement be removed from the standard or include only Elements that were tripped in the last calendar year.</p> <p>Response: The “January 1, 2003” date has been removed from the standard. Requirement R2 (and new R3) are based on actual Disturbances that occur after the Effective Date of the standard. Change made.</p> <p>It must be noted that the standard is unsupported by the Protection System Response to Power Swings, System Protection and Control Subcommittee, August, 2013 document. Referring to p. 20, the “Need for a Standard” section, states “Based on its review of historical events, consideration of the trade-offs between dependability and security, and recognizing the indirect benefits of implementing the transmission relay loadability standard (PRC-023), the SPCS concludes that a NERC Reliability Standard to address relay performance during stable swings is not needed, and could result in unintended adverse impacts to Bulk-Power System reliability.” (Emphasis added).</p> <p>Response: The “January 1, 2003” date has been removed from the standard. Requirement R2 (and new R3) are based on actual Disturbances that occur after the Effective Date of the standard. Change made.</p>

Organization	Yes or No	Question 1 Comment
		<p>The following report references support the PSRPS document’s conclusion that this standard is not needed:</p> <ol style="list-style-type: none"> <li>1) Page 8 of 61, 1965 Northeast Blackout Conclusion, first sentence “Relays tripping due ...”</li> <li>2) Page 8 of 61, 1977 New York Blackout Conclusions, first sentence, “Relays tripping due...”</li> <li>3) Page 9 of 61, July 2-3, 1996: West Coast Blackout Conclusions, first sentence “Relays tripping due...”</li> <li>4) Page 10 of 61, August 10, 1996 Conclusions, first sentence, “Relays tripping due...”</li> <li>5) Page 16 of 61, 2003 Northeast Blackout Conclusion, “Relays tripping due...”</li> <li>6) Page 17 of 61, Overall Observations from Review of Historical Events, first and second sentences, “Relays tripping...”</li> <li>7) Page 19 of 61, final paragraph, “Given the ....”NERC’s informational filing in Docket No. RM08-13-000 dated July 21, 2011 concluded that there is a need for a standard on stable power swings. The subsequently developed PSRPS document, which was developed by industry experts and approved by the NERC Planning Committee, clearly refutes the FERC directive in Order No. 773 (Docket No. RM08-13-000), that was subsequently affirmed in Order Nos. 773-A and 773-B, that a standard is needed to ensure that load-responsive protective relays do not trip in response to stable power swings during non-Fault conditions.</li> </ol> <p>We recommend that the NERC Standards Committee explore means to utilize the more recent PSRPS document to obtain relief from the aforementioned FERC directive that is driving this project.</p> <p>Response: Please see the section at the beginning of this document called, “NERC Discussion on Proceeding(s) and Directives Regarding: Stable Power Swings” for a complete background. The SDT understands that NERC staff re-engaged FERC staff following the completion of the PSRPS Report and that the Commission still desired NERC to pursue its work to meet the directive. However, FERC staff was open to an approach designed by NERC. NERC staff has informally received positive feedback on the approach to address the regulatory directive. The directive itself was challenged by commenters prior to the</p>

Organization	Yes or No	Question 1 Comment
		<p>issuance of Order No. 733 and was already the subject of multiple rehearing requests in the Order No. 733-A and Order No. 733-B proceedings. Similar arguments to the conclusions of the NERC System Protection and Control Subcommittee were advanced in these FERC proceedings.</p>
SMUD/BANC	No	<p>(1) Collected data and subsequent analysis has not identified tripping during stable power swings. This phenomenon is rare if at all. Any tripping during stable power swings would more appropriately included as a mis-operation and addressed as such.</p> <p>Response: Please see the section at the beginning of this document called, “NERC Discussion on Proceeding(s) and Directives Regarding: Stable Power Swings” for a complete background. The SDT understands that NERC staff re-engaged FERC staff following the completion of the PSRPS Report and that the Commission still desired NERC to pursue its work to meet the directive. However, FERC staff was open to an approach designed by NERC. NERC staff has informally received positive feedback on the approach to address the regulatory directive. The directive itself was challenged by commenters prior to the issuance of Order No. 733 and was already the subject of multiple rehearing requests in the Order No. 733-A and Order No. 733-B proceedings. Similar arguments to the conclusions of the NERC System Protection and Control Subcommittee were advanced in these FERC proceedings.</p> <p>(2) The requirement R2 is particularly unacceptable as it requires data for pre June 18, 2007; effective date of Order 693 standards.</p> <p>Response: The “January 1, 2003” date has been removed from the standard. Requirement R2 (and new R3) are based on actual Disturbances that occur after the Effective Date of the standard. Change made.</p>
ISO RTO Council Standards Review Committee	No	<p>Conditions (2) and (3) are unclear.</p> <p>Condition (2) stipulates that the responsible entity notify the facility owner of an Element that is associated with a System Operating Limit (SOL) that has been established based on stability constraints. It’s not clear whether the Element is the contingent Element or the monitored Element or both. This needs to be clarified/specified in the standard/requirement.</p>

Organization	Yes or No	Question 1 Comment
		<p>Response: For Requirement R1, Criterion 2, the drafting team removed the term “associated” and revised the criteria to clarify that the Element is the “monitored” Element. Change made.</p> <p>Condition (3) stipulates that the responsible entity notify the facility owner of an Element that has formed the boundary of an island within an angular stability planning simulation where the system Disturbance(s) that caused the islanding condition continues to be a credible event. The term “credible event” is hard to determine since the Disturbance could be caused by one of those events listed in the TPL standards, or could be one that is beyond those listed, such as natural phenomena. We realize that the Application Guideline provides some general guidance on assessing the credibility of a Disturbance, but we do not agree that a Disturbance is no longer credible when it is deemed no longer capable of occurring in the future due to actual changes to the BES. Changes to the BES may reduce the possibility of the same Disturbance, but such Disturbances (e.g. loss of right of way or an entire station) may still occur due to other means. If the SDT should continue to hold the position that the criteria for excluding a Disturbance is that BES changes are made to mitigate (but not totally eliminate) the recurrence, then it should be clearly stated in the requirement itself.</p> <p>In short, the basis with which to deem a Disturbance “credible” is missing from the requirements, which needs to be provided/clarified in the standard/requirement.</p> <p>Response: The term “credible” has been removed from the standard. The drafting team clarified Requirement R1, Criterion 3 by framing the criterion in the present tense to refer to current assessment(s). The term “credible” was removed from the previous Requirement R2 (and new R3) because the required performance refers to only current actual events. Change made.</p>
ACES Standards Collaborators	No	<p>(1) This requirement needs to be further clarified that it is not intended to require additional studies. Rather, the TP, PC and RC are to identify the information in bullets 1 through 4 based on their existing knowledge and studies.</p> <p>Response: Requirement R1 sufficiently conveys that no new or additional studies are required. Additional clarification has been added to the Guidelines and Technical Basis. Change made.</p>



Organization	Yes or No	Question 1 Comment
		<p>(2) Part 2 needs further clarification regarding which SOLs should be applied. Are the SOLs established from the planning horizon per FAC-010-2.1 or the SOLs established in the operating horizon per FAC-011-2 applicable? We recommend that only SOLs from the operating horizon should be applied because the SOLs from the planning horizon may include the impact of proposed or retired facilities which could result in unnecessary relay modifications or miss necessary relay modifications.</p> <p>Response: Requirement R1, Criterion 1 and 2 address operating limits associated with angular stability limits; therefore, System Operating Limits (SOL) specified in Requirement R1, Criterion 2 includes both operations and planning horizons. In the event that a Corrective Action Plan (CAP) is necessary based on future system conditions, the CAP can specify a timeframe that does not enact changes until those system conditions require modification. An example has been added to clarify this scenario in the Guidelines and Technical Basis. Change made.</p> <p>(3) Requirement R1 as a whole is problematic because it is based partly on planning studies. Planning studies include proposed system additions and retirements which could result in the identification of unnecessary relay modifications or a failure to identify necessary relay modifications.</p> <p>Response: In the event that a Corrective Action Plan (CAP) is necessary based on future system conditions, the CAP can specify a timeframe that does not enact changes until the actual system modifications have occurred. No change made.</p> <p>(4) R1 should be split based on responsibilities. Some of the bullets should apply to only one entity. For example, an RC is required to monitor the status of Special Protection Systems per IRO-005-3.1a R1.1. The RC would also have to be aware of generating plant stability constraints. Thus, the RC could provide all of the information for bullet 1. Bullets 3 and 4 are based on planning studies and should only apply to the Planning Coordinator. If only SOLs from the operating horizon are to be evaluated, then bullet 2 should only apply to the RC.</p> <p>Response: The Reliability Coordinator and Transmission Planner have been removed from the standard's Applicability; therefore, Requirement R1 is now only applicable to the Planning Coordinator as a single entity source of identifying Elements. The drafting team asserts that the Planning Coordinator has or has</p>

Organization	Yes or No	Question 1 Comment
		<p>access to the knowledge including the wide-area view. Change made to the Requirement.</p> <p>(5) Part 2 should be modified to limit application to IROLs and not all stability related SOLs. By definition, if an SOL is stability related and is not an IROL, it cannot have a wide area impact on reliability and is limited to local reliability. If it had a wide area impact, it would cause “instability, uncontrolled separation or Cascading outages that adversely impact the reliability of the Bulk Electric System” and would be an IROL.</p> <p>Response: Several commenters questioned the use of a System Operating Limit (SOL) to determine Elements that needed evaluation because they were not necessarily associated with wide-area problems. The drafting team contends that not only SOLs that have been shown to expose a widespread area to instability, uncontrolled separation(s) or cascading outages should be considered. Identified localized instability issues also point to Elements that should reduce the likelihood of tripping for stable power swings. No change made.</p> <p>(6) Part 4 is problematic because it now requires relay tripping to be evaluated in transient studies performed by the Planning Coordinator and Transmission Planner. These entities may not include all relays in their studies but this part creates a de facto requirement for them to include all relays. Otherwise, how can a PC or TP determine if relay tripping would occur?</p> <p>Response: The drafting team asserts that the standard does not require the inclusion of relay models. Requirement R1 – Criterion 4 is not requiring a study, but the identification of any Element that was observed as tripping in the most recent Planning Assessment. No change made.</p> <p>(7) The language of the requirement needs to be clarified that the TP, PC and RC are to only identify elements in their area. This could be accomplished by adding “in its area” after “each Element.”</p> <p>Response: The drafting team clarified that the responsible entity is to identify Elements in its area. Change made.</p> <p>(8) The format of the sub-part numbering does not follow the convention that NERC established several years ago and notified the Commission that it would use for sub-parts. When all sub-parts are required then they are to be numbered. When only one sub-part is requirement (i.e. one of the list has to be</p>

Organization	Yes or No	Question 1 Comment
		<p>selected), they are to be bulleted. The draft appears to stray because of the language “one or more” in the main requirement. In other words, one item could be met or more than one. However, we argue that bullets should be used because while more than one could apply, if one applies the Element is to be identified by the PC, TP, or RC. There is no additional need for any tests once one is met. Thus each Element will only be identified as meeting one of the bullets because that means it qualifies even though it could meet more than one.</p> <p>Response: The NERC convention for use of bullets and numbering is for identifying which items are “options” and which items are “all-inclusive:” however, in the use of criteria a numbered list (i.e., not using sub-part conventions) is acceptable. No change was made based on the comment.</p> <p>(9) Why can’t the islanding evaluation conducted per PRC-006-1 R1 be used as the basis for identifying Elements rather than writing a new bullet 3 in the requirement?</p> <p>Response: The drafting team modified Requirement R1, Criterion 3 to include island boundaries due to angular instability within an underfrequency load shedding (UFLS) assessment. Also, the Generator Owner was moved from Requirement R2 to the new Requirement R3 in order to remove the “islanding” criteria for Generator Owners. Change made.</p>
FirstEnergy Corp.	No	<p>FirstEnergy agrees with the focus approach using the criteria but has the following concern. It is understood that the “... since January 1, 2003” verbiage is intended to capture applicable relay operations during the Aug. 14, 2003 event. It will be difficult if not nearly impossible for a GO, especially in a deregulated environment, to piece together details of relay operations prior to record-keeping requirements for NERC PRC-004. We recommend that these Criteria be reworded to include only incidents which have occurred since the inception of NERC PRC-004.</p> <p>Response: The “January 1, 2003” date has been removed from the standard. Requirement R2 (and new R3) are based on actual Disturbances that occur after the Effective Date of the standard. Change made.</p>
Duke Energy	No	<p>(1) Based on the SPCS report stated below (dated August 2013), Duke Energy does not believe that adequate technical justification has been identified for this project to become a standard. The SDT and</p>

Organization	Yes or No	Question 1 Comment
		<p>NERC should consider moving this project to a Guideline document until such time as a standard is warranted.</p> <p>“Based on its review of historical events, consideration of the trade-offs between dependability and security, and recognizing the indirect benefits of implementing the transmission relay loadability standard (PRC-023), the SPCS concludes that a NERC Reliability Standard to address relay performance during stable power swings is not needed, and could result in unintended adverse impacts to Bulk-Power System reliability.”</p> <p>Response: Please see the section at the beginning of this document called, “NERC Discussion on Proceeding(s) and Directives Regarding: Stable Power Swings” for a complete background. The SDT understands that NERC staff re-engaged FERC staff following the completion of the PSRPS Report and that the Commission still desired NERC to pursue its work to meet the directive. However, FERC staff was open to an approach designed by NERC. NERC staff has informally received positive feedback on the approach to address the regulatory directive. The directive itself was challenged by commenters prior to the issuance of Order No. 733 and was already the subject of multiple rehearing requests in the Order No. 733-A and Order No. 733-B proceedings. Similar arguments to the conclusions of the NERC System Protection and Control Subcommittee were advanced in these FERC proceedings.</p> <p>(2) Duke Energy does not agree with the criteria specified in R1 because sufficient tools have not been developed at this time for the industry to conduct the appropriate assessment and identification of the Elements in Criteria 4. However, if this project moves forward as a standard we suggest the following revision to Criteria 4:</p> <p>“4. An Element identified in the most recent Planning Assessment where relay tripping occurred as a result of a power swing during the simulated Disturbance. Generic modeling of relays is acceptable when conducting this initial Planning Assessment.”</p> <p>This would provide the necessary flexibility until such a time as tools are developed to conduct a more accurate Planning Assessment and identification of Elements for Criteria 4.</p> <p>Response: The drafting team asserts that the standard does not require the inclusion of relay models.</p>

Organization	Yes or No	Question 1 Comment
		Requirement R1 – Criterion 4 is not requiring a study, but the identification of any Element that was observed as tripping in the most recent Planning Assessment. No change made.
BC Hydro	No	<p>Any approach should be based on experience with improper operation during stable power swings. If there has been no experience of undesired operation during stable power swings then checking against the criteria just results in fruitless work.</p> <p>Response: Please see the section at the beginning of this document called, “NERC Discussion on Proceeding(s) and Directives Regarding: Stable Power Swings” for a complete background. The SDT understands that NERC staff re-engaged FERC staff following the completion of the PSRPS Report and that the Commission still desired NERC to pursue its work to meet the directive. However, FERC staff was open to an approach designed by NERC. NERC staff has informally received positive feedback on the approach to address the regulatory directive. The directive itself was challenged by commenters prior to the issuance of Order No. 733 and was already the subject of multiple rehearing requests in the Order No. 733-A and Order No. 733-B proceedings. Similar arguments to the conclusions of the NERC System Protection and Control Subcommittee were advanced in these FERC proceedings.</p> <p>The drafting team asserts that the standard is proactively addressing the risk of load-responsive protective relays applied on Elements that are expected to have the greatest risk of exposure to power swings. The standard is based on guidance from the PSRPS Report and includes Elements that trip during future events. No change made.</p>
Florida Municipal Power Agency	No	As recognized by the SCPS, the standard is not needed and will result in a reduction of reliability to the bulk-power system (see report of footnote 1, Chapter 3, section titled “Need for a Standard”). FMPA strongly agrees with the SCPS that it is better for bulk-power system reliability to bias the “Art of Protection” to enable the power system to separate for unstable power swings than to bias the art of protection to prevent operation for stable power swings since it is very difficult, if not impossible, to distinguish stable from unstable power swings. We ought to enable the power system to gracefully degrade for unstable events rather than cause entire Interconnections to become unstable. We cannot with accuracy pre-determine where the separation points are or ought to be since we cannot know in

Organization	Yes or No	Question 1 Comment
		<p>advance where or what the cause of instability may occur. As such, having relays throughout the system that can cause separation as needed to prevent the entire Interconnection from going unstable is recommended.</p> <p>As such, and recognizing that we are directed to have a standard, the standard should not require PCs, RCs and TPs to identify that for every Element that meets the criteria of R1, something needs to be done (which is implied in R3). Rather, the PC, RC and TP ought to have discretion as to whether they want a potential issue resolved or not within R1. That is, the PC, RC and TP should have discretion as to whether to bias the performance towards separation for unstable power swings (graceful degradation for instability, but possibly contribute to cascading for stable power swings - although there is no evidence of the latter from past events), or bias the performance to prevent operation for stable power swings (which would have a tendency to cause blackouts to be greater in magnitude, but possibly reduce the risk of cascading for stable power swings, although there is no evidence of the latter), noting that there is no dependable way to distinguish between stable and unstable power swings. As such, the PC, RC and TP ought to be able to identify a subset of Elements that meet the criteria of R1 that would then be analyzed in R2 and R3.</p> <p>Response: The drafting team asserts that it has implemented an approach consistent with the recommendations of the NERC System Protection and Control Subcommittee (SPCS) technical report, <i>Protection System Response to Power Swings, August 2013</i><sup>5</sup> (PSRPS Report). The standard does not preclude the Planning Coordinator providing information to the Generator Owner or Transmission Owner about the Element and any known stability issues, power swings, or apparent impedance characteristics; however, the Elements need to be reported as a part of ensuring the Generator Owner and Transmission Owner are aware of Elements that are susceptible. Modifications were made to have only the Planning Coordinator identify Elements and in Requirement R5 to have the Generator Owner and Transmission Owner develop a Corrective Action Plan to meet the criteria PRC-026-1 – Attachment B while maintaining</p>

<sup>5</sup> NERC System Protection and Control Subcommittee, *Protection System Response to Power Swings*, August 2013: [http://www.nerc.com/comm/PC/System%20Protection%20and%20Control%20Subcommittee%20SPCS%2020/SPCS%20Power%20Swing%20Report\\_Final\\_20131015.pdf](http://www.nerc.com/comm/PC/System%20Protection%20and%20Control%20Subcommittee%20SPCS%2020/SPCS%20Power%20Swing%20Report_Final_20131015.pdf)

Organization	Yes or No	Question 1 Comment
		<p>dependable fault detection and dependable out-of-step tripping. The drafting team asserts protective relays that meet the PRC-026-1 – Attachment B criteria are expected to not trip during stable power swings. Change made.</p> <p>Note also that “Element” is the wrong term and “Facility” should be used. “Element” applies to both BES and non-BES (including distribution), Facilities is BES. Standards cannot be written to distribution.</p> <p>Response: Section 4.2, Facilities provides sufficient language that the standard is applicable to only “BES Elements.” No change made to the standard based upon the comment.</p>
Puget Sound Energy	No	<p>For systems that have not experienced a power swing that caused a trip or islanding condition, there is the burden of proving the negative to demonstrate compliance with the standard. It is recommended that Requirement R2 be rewritten in such a way that entities will not have to prove the negative.</p> <p>Response: The drafting team contends it is up to the entity to certify that no trips occurred due to stable or unstable power swings during audit period. The intent is not for an entity to prove the negative, but for an entity to certify that no Elements met the criteria in Requirement R2.No Change made.</p> <p>It is also recommended that the standard be revised to address the situation where historical data is not available as far back as 2003. We also request that a NERC definition be provided for what constitutes a stable power swing and what criteria can be applied to historical data to determine if a stable power swing has occurred.</p> <p>Response: The “January 1, 2003” date has been removed from the standard. Requirement R2 (and new R3) are based on actual Disturbances that occur after the Effective Date of the standard. Change made.</p>
Bonneville Power Administration	No	<p>BPA agrees with the approach, with two exceptions.</p> <p>First, BPA feels more clarity is needed regarding which Elements are associated with System Operating Limits (SOLs), relevant to the Standard. Stability constraints can depend on the overall topology of the system, in which case nearly every Element in the power system would meet the criteria of item 2. For example, BPA may determine a stability constraint on WECC Path 66 due to poorly damped oscillations.</p>

Organization	Yes or No	Question 1 Comment
		<p>Taking almost any 500 kV or 345 kV line out of service on the western side of WECC could change the value of this limit, in which case all of these Elements meet the criteria of item 2. BPA suggests the language be changed to:</p> <p style="padding-left: 40px;">2. An Element that has been shown to have a substantial effect on a System Operating Limit (SOL) that has been established based on stability constraints identified in system planning or operating studies (including line-out conditions.)</p> <p>Response: For Requirement R1, Criterion 2, the drafting team removed the term “associated” and revised the criteria to clarify that the Element is the “monitored” Element. Change made.</p> <p>Secondly, BPA feels the Glossary definition of Disturbance lacks sufficient clarity as it relates to this and other existing Standards.</p> <p>Response: The drafting team revised Requirement R1, Criterion 4 by changing “Disturbance” to “simulated disturbance” to comport with the approved Reliability Standard TPL-001-4. The use of “Disturbance” in Requirements R2 (TO) and R3 (GO) relates to an actual system disturbance. Change made.</p>
Luminant Generation Company LLC	No	<p>The focused approach is too narrow for Generation Owners in that it restricts to the Transmission Planner and Generation Owner to events that have occurred and not a Planning Assessment transient stability study results that indicate load responsive relay operation is challenged. Item #4 in Requirement R1 may not capture all power system swings since it is focused on previous events. Luminant recommends that the Transmission Planner be responsible for transient stability studies and reporting the information to the Generation Owner for locations where load responsive relays are challenged.</p> <p>Response: The drafting team revised Requirement R1, Criterion 4 by changing “Disturbance” to “simulated disturbance” to comport with the approved Reliability Standard TPL-001-4. The use of “Disturbance” in Requirements R2 (TO) and R3 (GO) relates to an actual system disturbance. The Reliability Coordinator and Transmission Planner have been removed from the standard’s Applicability; therefore, Requirement R1 is now only applicable to the Planning Coordinator as a single entity source of</p>



Organization	Yes or No	Question 1 Comment
		<p>identifying Elements. The drafting team asserts that the Planning Coordinator has or has access to the knowledge including the wide-area view. Change made to the Requirement.</p> <p>The date of 2003 needs to be removed from the standard as it prefaces compliance on data that predates the approval of the standard.</p> <p>Response: The "January 1, 2003" date has been removed from the standard. Requirement R2 (and new R3) are based on actual Disturbances that occur after the Effective Date of the standard. Change made.</p> <p>Also, the Generation Owner and Transmission Owner (in cases where the Transmission Planner and Transmission Owner are not the same entity) do not have the tools to determine if the BES is configured such that a Disturbance event is still credible.</p> <p>Luminant believes that R2 criteria 1 and 2 need to be modified as follows:</p> <ul style="list-style-type: none"> <li>"1. An Element that load responsive relaying has tripped during the past calendar year due to a power swing during an actual system Disturbance. "</li> <li>"2. An Element that has formed the boundary of an island during the past calendar year during an actual system Disturbance."</li> </ul> <p>Response: The term "credible" has been removed from the standard. The drafting team clarified Requirement R1, Criterion 3 by framing the criterion in the present tense to refer to current assessment(s). The term "credible" was removed from the previous Requirement R2 (and new R3) because the required performance refers to only current actual events. Change made.</p>
Ingleside Cogeneration LP	No	<p>Ingleside Cogeneration LP ("ICLP") believes that the drafting team has generally captured the intent of FERC Order 733 by specifying the planning and operations criteria used to identify susceptible Elements. Clearly those load responsive relays that protect Elements that have a stability constraint or are tripped in response to a stable power swing should be in scope.</p> <p>However, we do not agree that those Elements that form the boundary of an island during planning assessments or as a result of an actual Disturbance should be subject to PRC-026-1.</p>

Organization	Yes or No	Question 1 Comment
		<p>Response: The drafting team removed the islanding requirement from the responsibility of the Generator Owner (now Requirement R3). The islanding criteria remains in Requirement R1 (Planning Coordinator) and the new Requirement R2 (Transmission Owner); therefore, keeping the standard approach consistent with the PSRPS Report recommendation. Change made.</p> <p>Our assertion is based upon a reading of the FERC directive in Order 733, which responds to a stakeholder suggestion that islanding strategies are a reasonable approach to limit the effect of a relay that improperly reacts to a stable power swing. Instead, the project team has interpreted the ruling as a means to identify susceptible Elements - adding an unnecessary burden to every relay owner and planner in the annual assessment process. In our view, the item should be re-positioned as a bullet point in R3, which allows the TO or GO to show that an islanding scheme sufficiently protects the greater BES against instability. This would be similar to the acknowledgement that power swing blocking limits the effect of a load relay trip - essentially another mitigation strategy that may be used address a situation where the relay settings themselves cannot be changed for some reason.</p> <p>Response: The drafting team contends that it followed the FERC directive to consider islanding strategies and simply includes the Elements that form the boundaries of islands to be evaluated with regard to tripping during stable power swings. The team contends that islanding strategies are developed to isolate the system from unstable power swings, which is still allowed under the proposed PRC-026-1. No change made.</p>
Public Service Enterprise Group	No	<p>The entire standard is unsupported by the PSRPS document. See p. 20 in the "Need for a Standard" section, which states "Based on its review of historical events, consideration of the trade-offs between dependability and security, and recognizing the indirect benefits of implementing the transmission relay loadability standard (PRC-023), THE SPCS CONCLUDES THAT A NERC RELIABILITY STANDARD TO ADDRESS RELAY PERFORMANCE DURING STABLE POWER SWINGS IS NOT NEEDED, AND COULD RESULT IN UNINTENDED ADVERSE IMPACTS TO BULK-POWER SYSTEM RELIABILITY." (Emphasis added by CAPITALIZATION.) See the specific report references below that support the PSRPS document's conclusion that this standard is not needed:</p>

Organization	Yes or No	Question 1 Comment
		<p>1) Page 8 of 61, 1965 Northeast Blackout Conclusion, first sentence “Relays tripping due ...”</p> <p>2) Page 8 of 61, 1977 New York Blackout Conclusions, first sentence, “Relays tripping due...”</p> <p>3) Page 9 of 61, July 2-3, 1996: West Coast Blackout Conclusions, first sentence “Relays tripping due...”</p> <p>4) Page 10 of 61, August 10, 1996 Conclusions, first sentence, “Relays tripping due...”</p> <p>5) Page 16 of 61, 2003 Northeast Blackout Conclusion, “Relays tripping due...”</p> <p>6) Page 17 of 61, Overall Observations from Review of Historical Events, first and second sentences, “Relays tripping...”</p> <p>7) Page 19 of 61, final paragraph, “Given the ....”The PSRPS document, developed by industry experts and approved by the NERC Planning Committee, clearly disputes the FERC directive in Order No. 773 (Docket No. RM08-13-000), that was subsequently affirmed in Order Nos. 773-A and 773-B, that a standard is needed to ensure that load-responsive protective relays do not trip in response to stable power swings during non-Fault conditions. NERC’s informational filing in Docket No. RM08-13-000 dated July 21, 2011 concluded that there is a need for a standard on stable power swings. This conclusion is the opposite of what the PSRPS document concluded.</p> <p>We recommend that the NERC Standards Committee explore means to utilize the more recent PSRPS document to obtain relief from the aforementioned FERC directive that is driving this project.</p> <p>Response: Please see the section at the beginning of this document called, “NERC Discussion on Proceeding(s) and Directives Regarding: Stable Power Swings” for a complete background. The SDT understands that NERC staff re-engaged FERC staff following the completion of the PSRPS Report and that the Commission still desired NERC to pursue its work to meet the directive. However, FERC staff was open to an approach designed by NERC. NERC staff has informally received positive feedback on the approach to address the regulatory directive. The directive itself was challenged by commenters prior to the issuance of Order No. 733 and was already the subject of multiple rehearing requests in the Order No. 733-A and Order No. 733-B proceedings. Similar arguments to the conclusions of the NERC System Protection and Control Subcommittee were advanced in these FERC proceedings.</p>

Organization	Yes or No	Question 1 Comment
Los Angeles Department of Water and Power	No	<p>LADWP opposes the criteria from Requirement 2 that proposed looking back on Elements since 2003. Requirements cannot be applied retroactively.</p> <p>Response: The "January 1, 2003" date has been removed from the standard. Requirement R2 (and new R3) are based on actual Disturbances that occur after the Effective Date of the standard. Change made.</p>
Massachusetts Attorney General	No	<p>R2 requires GOs and TOs to evaluate Disturbance records "since January 1, 2003," a time that will precede the effective date of this standard. A requirement cannot rely upon records that precede the effective date of a standard.</p> <p>Response: The "January 1, 2003" date has been removed from the standard. Requirement R2 (and new R3) are based on actual Disturbances that occur after the Effective Date of the standard. Change made.</p>
MidAmerican Energy Company	No	<p>The approach for R2 is incorrect. NERC standards cannot require compliance prior to the effective date of the standard itself. All references to 2003 should be deleted from the requirements and any guidance. Deleting the references to 2003 would make the requirement effective upon the effective date of the standard.</p> <p>Response: The "January 1, 2003" date has been removed from the standard. Requirement R2 (and new R3) are based on actual Disturbances that occur after the Effective Date of the standard. Change made.</p>
Consolidated Edison, Inc.	No	<p>We agree with a focused approach as outlined in the technical document. However, we have the following serious concerns with criteria in the requirements:</p> <ol style="list-style-type: none"> <li>The term "credible event" should be clearly defined. The basis to determine a credible event is missing from the requirement and application guide. This basis should be provided in the standard requirement.</li> </ol> <p>Response: The term "credible" has been removed from the standard. The drafting team clarified Requirement R1, Criterion 3 by framing the criterion in the present tense to refer to current assessment(s). The term "credible" was removed from the previous Requirement R2 (and new R3) because the required performance refers to only current actual events. Change made.</p>

Organization	Yes or No	Question 1 Comment
		<p>2. Why is the standard focused on SOL rather than IROL? The basis for specifying SOL is not supported by the example in the application guideline since the example did not show inter-area impact.</p> <p>Response: Several commenters questioned the use of a System Operating Limit (SOL) to determine Elements that needed evaluation because they were not necessarily associated with wide-area problems. The drafting team contends that not only SOLs that have been shown to expose a widespread area to instability, uncontrolled separation(s) or cascading outages should be considered. Identified localized instability issues also point to Elements that should reduce the likelihood of tripping for stable power swings. No change made.</p> <p>3. It is not clear in R1, criteria number 4 whether the assessment should include relay tripping or just stable power swing or both stable and unstable power swing.</p> <p>Response: Requirement R1 – Criterion 4, Requirement R2 – Criterion 1, and the new Requirement R3 – Criterion 1, were clarified by adding both “stable and unstable” power swings. Both stable and unstable power swings determine whether an Element will be identified as experiencing a power swing. Change made.</p> <p>4. In R2, it is unrealistic to require an entity to provide data on an Element that had tripped since 2003. There is no existing NERC continent-wide disturbance monitoring or misoperation standard that requires data be retained more than 12 months. We recommend that this requirement be removed from the standard or include only Elements that were tripped in the last calendar year.</p> <p>Response: The “January 1, 2003” date has been removed from the standard. Requirement R2 (and new R3) are based on actual Disturbances that occur after the Effective Date of the standard. Change made.</p>
Electric Reliability Council of Texas, Inc.	No	<p>The time periods in the requirements are unnecessarily restrictive, particularly R1, which essentially requires the work to be done in January of each year. There does not appear to be a reliability reason to have the work completed in January as long as the GO and TO perform the necessary actions in R3 in a timely manner. We suggest taking an approach similar to PRC-023 R6. In this case R1 would begin:</p> <p>“Each Planning Coordinator, Reliability Coordinator, and Transmission Planner shall conduct an</p>

Organization	Yes or No	Question 1 Comment
		<p>assessment at least once each calendar year, with no more than 15 months between assessments..."</p> <p>R2 through R4 could use a similar approach.</p> <p>Response: The Requirement R1 language about "January of each calendar" has been removed and replaced with "each calendar year." Based on time period changes in other Requirements, the drafting team determined that an annual periodicity in Requirement R1 is more appropriate. Change made.</p> <p>The identification of Elements in R1 seems to be unnecessarily redundant between the applicable entities for some criteria and inappropriate for other criteria. ERCOT suggests splitting R1 into two separate requirements based on the responsible entity: one requirement for the Planning Coordinator to identify elements per criteria 2, 3, and 4; and one requirement for the Reliability Coordinator to identify elements per criterion 1.</p> <p>The Transmission Planner should be removed from the Applicability of the standard, including removal from R3.</p> <p>Response: The Reliability Coordinator and Transmission Planner have been removed from the standard's Applicability; therefore, Requirement R1 is now only applicable to the Planning Coordinator as a single entity source of identifying Elements. The drafting team asserts that the Planning Coordinator has or has access to the knowledge including the wide-area view. Change made to the Requirement.</p>
Independent Electricity System Operator	No	<p>The criteria used to limit the applicability of the transmission lines are unclear. Specifically,</p> <ul style="list-style-type: none"> <li>Regarding Criteria 1 in Requirement 1, entities' may employ SPS to avoid tripping of any Element for stable power swings under all normal recognized contingencies included in the TPL standards. Given that the SPS is used as a mitigation measure, should this proposed standard be applicable to those elements that are susceptible to trip for stable power swings, when a failure of the SPS is considered?</li> </ul> <p>Response: The drafting team contends that the Special Protection System (SPS) as stated in Requirement</p>

Organization	Yes or No	Question 1 Comment
		<p>R1 is in place to prevent angular instability. The standard does not address a failing SPS, but is addressing the Elements associated with an SPS that would be susceptible to a power swing. (Note: The use of SPS has been replaced with Remedial Action Scheme (RAS) for consistency with a current project to revise the definition of “Special Protection System”). No change made.</p> <ul style="list-style-type: none"> <li>Similar to the above, for Criteria 2 in Requirement 1, entities’ may establish an SOL to avoid tripping of any Element for stable power swings under all normal recognized contingencies included in TPL standards. Given that SOL is used as a mitigation measure, should those elements susceptible to trip for stable power swings, when the SOL is exceeded (and which is not allowed in normal operation conditions) be applicable to this proposed standard?</li> </ul> <p>Response: The drafting team contends that a System Operating Limit (SOL) as stated in Requirement R1 is in place to prevent angular instability. The standard addresses Elements associated with an SOL as an Element that would be susceptible to a power swing. No change made.</p> <ul style="list-style-type: none"> <li>Requirement 1 stipulates that the responsible entity notify the facility owner of an Element that meets Criteria 2 (i.e., an Element associated with a System Operating Limit (SOL) that has been established based on stability constraints). It is not clear whether the Element is the contingent Element or the monitored Element or both. This needs to be clarified/specified in the standard/requirement.</li> </ul> <p>Response: For Requirement R1, Criterion 2, the drafting team removed the term “associated” and revised the criteria to clarify that the Element is the “monitored” Element. Change made.</p> <ul style="list-style-type: none"> <li>Requirement 1 stipulates that the responsible entity notify the facility owner of an Element that meets Criteria 3 (i.e., has formed the boundary of an island within an angular stability planning simulation where the system Disturbance(s) that caused the islanding condition continues to be a credible event. The term “credible event” is hard to determine since the Disturbance could be caused by one of those events listed in the TPL standards, or could be one that is beyond those listed, such as natural phenomena.</li> <li>We realize that the Application Guideline provides some general guidance on assessing the</li> </ul>

Organization	Yes or No	Question 1 Comment
		<p>credibility of a Disturbance, but we do not agree that a Disturbance is no longer credible when it is deemed no longer capable of occurring in the future due to actual changes to the BES. Changes to the BES may reduce the possibility of the same Disturbance, but such Disturbances (e.g. loss of right of way or an entire station) may still occur due to other means. If the SDT should continue to hold the position that the criteria for excluding a Disturbance is that BES changes are made to mitigate (but not totally eliminate) the recurrence, then it should be clearly stated in the requirement itself.</p> <ul style="list-style-type: none"> <li>In short, the basis with which to deem a Disturbance “credible” is missing from the requirements, which needs to be provided/clarified in the standard/requiremen</li> </ul> <p>Response: The term “credible” has been removed from the standard. The drafting team clarified Requirement R1, Criterion 3 by framing the criterion in the present tense to refer to the current assessment(s). Islands caused by natural phenomena (i.e., Disturbances) are covered under Requirement R2. Change made.</p>
David Kiguel	No	<p>1. The second criterion in R1 refers to "An Element that is associated with a System Operating Limit (SOL)." Clarification is necessary to specify the meaning of "associated." Does it refer to an Element in the SOL itself or monitored and protected but outside the SOL (or both)?</p> <p>Response: For Requirement R1, Criterion 2, the drafting team removed the term “associated” and revised the criteria to clarify that the Element is the “monitored” Element. Change made.</p> <p>2. The draft repeatedly uses the term “credible event.” In some instances, e.g. past disturbance(s) it might be subject to interpretation. In general, without a probabilistically quantified criterion, the term "credible" is subjective and subject to interpretation, thus should be avoided in this context.</p> <p>Response: The term “credible” has been removed from the standard. The drafting team clarified Requirement R1, Criterion 3 by framing the criterion in the present tense to refer to current assessment(s). The term “credible” was removed from the previous Requirement R2 (and new R3) because the required performance refers to only current actual events. Change made.</p>



Organization	Yes or No	Question 1 Comment
		<p>3. Clarification is required in regards to load-responsive relays in a Protection System. It is unclear as to what relays/components should not trip during power swing.</p> <p>Response: The term “load-responsive protective relays” is widely understood and is any protective functions which could trip with or without time delay, on load current. A clarification has been provided in PRC-026-1 – Attachment A. Change made.</p> <p>4. R2 requires GOs and TOs to evaluate Disturbance records “since January 1, 2003,” a time that will precede the effective date of this standard. A requirement cannot rely upon records that precede the effective date of a standard.</p> <p>Response: The “January 1, 2003” date has been removed from the standard. Requirement R2 (and new R3) are based on actual Disturbances that occur after the Effective Date of the standard. Change made.</p>
California ISO	No	<p>As “line-out conditions” used in Requirement R1 Criteria 1 and 2 is not a defined term, please clarify the intent of “line-out conditions”, particularly addressing if “line-out conditions” are expected to go beyond the TPL Standard(s) of what the Planning Coordinator and Transmission Planner already study.</p> <p>Response: The phrase “line-out conditions” has been removed. Elements should be identified based on the Requirement R1 criterion regardless of the outage conditions that may be necessary to trigger enforcement of the System Operating Limit (SOL) or arming of the Special Protection System (SPS). The Guidelines and Technical Basis have been supplemented to provide additional information. (Note: The use of SPS has been replaced with Remedial Action Scheme (RAS) for consistency with a current project to revise the definition of “Special Protection System”). Change made.</p>
Tacoma Power	No	<p>Tacoma Power supports PSEG’s response to Question 1.</p> <p>Setting aside the previous comment (that is, assuming FERC does not provide relief from its directive to develop this standard), Tacoma Power supports a narrower approach. That is, the screening criteria should be refined and made simpler. For example, PRC-023 applies relatively straightforward screening criteria, yet PRC-023 addresses a greater reliability risk than the proposed PRC-026-1.</p>

Organization	Yes or No	Question 1 Comment
		<p>Presently, PRC-026-1 Requirement R1 (and R2) could pose a greater burden on entities than PRC-023 for screening to identify applicable Facilities. Alternatives might be to conduct a data request to collect better information so that Requirements R1 and R2 could be consolidated and then provide more refined and simpler criteria.</p> <p>Response: The drafting team contends that the standard approach is consistent with the PSRPS Report recommendation. Also, PRC-023 includes all BES Elements above 200 kV and select Elements below 200 kV and the proposed PRC-026-1 is a narrow focus on BES Elements at greater risk of power swings. Requirement R1 is not requiring additional or new studies; it is relying on existing studies. The burden of Requirement R2 (and new R3) has been reduced by eliminating the need to evaluate Disturbances prior to the Effective Date of the standard. Changes made.</p> <p>Setting aside the previous comment, Criterion 4 needs more clarification.</p> <p>Response: Requirement R1 – Criterion 4, Requirement R2 – Criterion 1, and the new Requirement R3 – Criterion 1, were clarified by adding both “stable and unstable” power swings. Both stable and unstable power swings determine whether an Element will be identified as experiencing a power swing. Change made.</p> <p>Response: The drafting team asserts that the standard does not require the inclusion of relay models. Requirement R1 – Criterion 4 is not requiring a study, but the identification of any Element that was observed as tripping in the most recent Planning Assessment. No change made.</p> <p>What is the technical basis in Requirement R1 for identification and notification to occur in January of each year?</p> <p>Response: The Requirement R1 language about “January of each calendar” has been removed and replaced with “each calendar year.” Based on time period changes in other Requirements, the drafting team determined that an annual periodicity in Requirement R1 is more appropriate. Change made.</p>
Ameren	No	(1) Along with our comments we agree with and adopt the Public Service Enterprise Group (PSEG)

Organization	Yes or No	Question 1 Comment
		<p>Comments by reference.</p> <p>Response: Thank you for your comment.</p> <p>(2) If this standard does proceed, we generally can accept the focused approach, but believe it should be narrower. We believe that R2 reaching all the way back to 1/1/2003 creates an ex post facto compliance obligation.</p> <p>Response: The “January 1, 2003” date has been removed from the standard. Requirement R2 (and new R3) are based on actual Disturbances that occur after the Effective Date of the standard. Change made.</p> <p>(3) In our opinion R1 needs to limit the Criteria 3 and 4 time horizon to Operations Planning to be consistent with R3 which deals with the existing Protection System. We believe that resetting an existing relay for a future, but not present, stability issue could harm present reliability. Although, we do understand the benefits of identifying a future stability concern, and a future need to possibly alter relaying schemes or reset relays in an orderly fashion is important; we believe that such activity is part of the planning process and need not be governed by this standard. However, if the SDT intended that the R3 CAP (3rd bullet) apply to future scenarios, then please add the timing of such an example in the Application Guidelines.</p> <p>Response: Requirement R1 has been revised to only include the Planning Coordinator and due to this revision, the Criterion that identifies Elements is now specifically assigned the Time Horizon: Long-term Planning. In the event that a Corrective Action Plan (CAP) is necessary based on future system conditions, the CAP can specify a timeframe that does not enact changes until those system conditions require modification. An example has been added to clarify this scenario in the Guidelines and Technical Basis. Change made.</p> <p>(4) We ask the drafting team to include a broader explanation of changed conditions that would discontinue credibility in R2, item 2 (“...during an actual system Disturbance where the Disturbance(s) that caused the islanding condition continues to be credible.”).</p> <p>Include items such as completed PRC-004 CAPs that have fixed a contributing cause, and procedures to</p>

Organization	Yes or No	Question 1 Comment
		<p>avoid a unique maintenance switching topology that was causal.</p> <p>Response: The term “credible” has been removed from the standard. The drafting team clarified Requirement R1, Criterion 3 by framing the criterion in the present tense to refer to current assessment(s). The term “credible” was removed from the previous Requirement R2 (and new R3) because the required performance refers to only current actual events. Change made.</p> <p>Following the notification of a Disturbance to the Planning Coordinator in Requirements R2 by the Transmission Owner or by Requirement R3 by the Generator Owner, the Planning Coordinator in Requirement R1 will continue notifying the respective Generator Owner and Transmission Owner of the Element, unless the Planning Coordinator determines the Element is no longer susceptible to power swings.</p>
ISO New England	No	<p>ISO New England recommends that requirements R1, R2, and R3 be changed from an annual requirement to once every 60 months. We also think that the approach should be narrower.</p> <p>Response: The Requirement R1 language about “January of each calendar” has been removed and replaced with “each calendar year.” Based on time period changes in other Requirements, the drafting team determined that an annual periodicity in Requirement R1 is more appropriate.</p> <p>The drafting team revised Requirement R4 (previous R3) from “each calendar year” to “within 12 full calendar months of receiving notification of an Element pursuant to Requirement R1 or within 12 full calendar months of identifying an Element pursuant to Requirement R2 and R3,” and “where the evaluation has not been performed in the last three calendar years.” Three calendar years was selected over five calendar years because the implementation plan provides a greater length of time to implement the standard and future occurrences would be incremental. Change made.</p> <p>Criteria 1 should be limited to IROL’s and read as follows:</p> <ol style="list-style-type: none"> <li>1. An Element that is located or terminates at a generating plant, where a generating plant stability constraint exists and is addressed by an IROL.</li> </ol>

Organization	Yes or No	Question 1 Comment
		<p>Criteria 2 should be deleted. This criteria appears to be redundant to Criteria 1.</p> <p>Response: Criterion 1 is for identifying Bulk Electric System (BES) Elements associated with a Special Protection System (SPS) or operating limit associated generating plant. Criterion 2 is associated with identifying BES Elements with a System Operating Limit SOL that has been established based on angular stability constraints. (Note: The use of SPS has been replaced with Remedial Action Scheme (RAS) for consistency with a current project to revise the definition of “Special Protection System”). The drafting team contends that the standard approach is consistent with the PSRPS Report recommendation. No change made. Several commenters questioned the use of a System Operating Limit (SOL) to determine Elements that needed evaluation because they were not necessarily associated with wide-area problems. The drafting team contends that not only SOLs that have been shown to expose a widespread area to instability, uncontrolled separation(s) or cascading outages should be considered. Identified localized instability issues also point to Elements that should reduce the likelihood of tripping for stable power swings. No change made.</p> <p>In Criteria 3, Disturbance is too broad. It should be limited to single or multiple contingencies but not extreme contingencies. Criteria 3 should read as follows:</p> <p style="padding-left: 40px;">3. An Element that has formed the boundary of an island within an angular stability planning simulation where the system Disturbance(s) that caused the islanding is a single or multiple contingency but not an extreme contingency.</p> <p>Response: The drafting team modified Requirement R1, Criterion 3 to include island boundaries due to angular instability within an underfrequency load shedding (UFLS) assessment. Also, the Generator Owner was moved from Requirement R2 to the new Requirement R3 in order to remove the “islanding” criteria for Generator Owners. Change made.</p> <p>Criteria 4 should be narrower in scope and read as follows:</p> <p style="padding-left: 40px;">4. An Element identified in the most recent Planning Assessment where relay tripping occurred for a power swing during a Disturbance caused by a single or multiple contingency but not an extreme</p>

Organization	Yes or No	Question 1 Comment
		<p>contingency.</p> <p>Response: The drafting team asserts that the most recent Planning Assessment provides a concrete reference to the information used in identifying BES Elements. Since the Planning Assessments (i.e., TPL-001-4) are performed annually, any other description would create confusion as to whether an entity should use past information or information revealed during preparation of a Planning Assessment. No change made.</p> <p>Again, Disturbance is too broad. It should be limited to single or multiple contingencies but not extreme contingencies.</p> <p>Response: The drafting team revised Requirement R1, Criterion 4 by changing “Disturbance” to “simulated disturbance” to comport with the approved Reliability Standard TPL-001-4. The use of “Disturbance” in Requirements R2 (TO) and R3 (GO) relates to an actual system disturbance. Change made.</p>
New York Power Authority	No	<p>The PSRPS technical document does not recommend this Standard. This is stated in pages 5, 20, and 24: “Based on its review of historical events, consideration of the trade-offs between dependability and security, and recognizing the indirect benefits of implementing the transmission relay loadability standard (PRC-023), the SPCS concludes that a NERC reliability Standard to address relay performance during stable power swings is not needed, and could result in unintended adverse impacts to Bulk-Power System reliability.”</p> <p>Response: Please see the section at the beginning of this document called, “NERC Discussion on Proceeding(s) and Directives Regarding: Stable Power Swings” for a complete background. The SDT understands that NERC staff re-engaged FERC staff following the completion of the PSRPS Report and that the Commission still desired NERC to pursue its work to meet the directive. However, FERC staff was open to an approach designed by NERC. NERC staff has informally received positive feedback on the approach to address the regulatory directive. The directive itself was challenged by commenters prior to the issuance of Order No. 733 and was already the subject of multiple rehearing requests in the Order No. 733-A and Order No. 733-B proceedings. Similar arguments to the conclusions of the NERC System</p>

Organization	Yes or No	Question 1 Comment
		<p>Protection and Control Subcommittee were advanced in these FERC proceedings.</p> <p>We only agree with R1. R1 calls upon the Planning Coordinator, Reliability Coordinator, &amp; Transmission Planner, (all single ISO in our region) to provide notification to GOs and TOs of what the specific “Elements” are. R2 seems to again call for Elements by the GOs and TOs. R2 can easily be combined into R1 for a simpler answer. In addition, by practice all registered entities report to the ISO/RC any disturbances, being they are the System Operator and keep records of events in the region.</p> <p>Response: The Generator Owner (GO) in Requirement R3 and Transmission Owner (GO) in Requirement R2 are required to report the Element that tripped during a Disturbance in response to a power swing. These Requirements allow the Planning Coordinator to be the sole source of funneling the “identified Elements” to the GO and TO. A fifth Criterion was added to Requirement R1 that requires the Planning Coordinator (PC) to continue identifying an Element “unless the PC determines the Element is no longer susceptible to power swings.” This ensures visibility of the Elements reported by the GO or TO on an ongoing basis since the Element tripped in response to a power swing. Change made.</p>
Oncor Electric Delivery LLC	No	<p>Oncor does not agree that the approach of this Standard came from recommendations in the PSRPS technical document, but rather negates the need for the Standard altogether. Specifically, on page 5 paragraph 4 of the document it states “Based on its review of historical events, consideration of the trade-offs between dependability and security, and recognizing the indirect benefits of implementing the transmission relay loadability standard (PRC-023), the SPCS concludes that a NERC Reliability Standard to address relay performance during stable power swings is not needed, and could result in unintended adverse impacts to Bulk-Power System reliability”.</p> <p>Response: Please see the section at the beginning of this document called, “NERC Discussion on Proceeding(s) and Directives Regarding: Stable Power Swings” for a complete background. The SDT understands that NERC staff re-engaged FERC staff following the completion of the PSRPS Report and that the Commission still desired NERC to pursue its work to meet the directive. However, FERC staff was open to an approach designed by NERC. NERC staff has informally received positive feedback on the approach to address the regulatory directive. The directive itself was challenged by commenters prior to the</p>

Organization	Yes or No	Question 1 Comment
		<p>issuance of Order No. 733 and was already the subject of multiple rehearing requests in the Order No. 733-A and Order No. 733-B proceedings. Similar arguments to the conclusions of the NERC System Protection and Control Subcommittee were advanced in these FERC proceedings.</p> <p>Oncor agrees with this notion and does not want to add any adverse issues to the power system. This is also repeated on page 20 paragraph 1. In regards to the specific requirements, R1 criteria 1 states “An Element that is located or terminates at a generating plant, where a generating plant stability constraint exists and is addressed by an operating limit or a Special Protection System (SPS) (including line-out conditions).” This requirement duplicates the efforts in TPL-002 (R1.3.10), TPL-003(R1.3.10), TPL-004(R1.3.7), and TPL-001-4(R 2.7.1) where the effect of a SPS, which is a protection system, is already studied. Oncor recommends the SDT aligns the Requirements to eliminate duplication.</p> <p>Response: The drafting team contends that the Requirements do not duplicate the transmission (i.e., TPL standards) Requirements. The TPL standards address the effects of the planned actions of the Special Protection System (SPS), which is installed to address a stability constraint. The Elements are included because other relays protecting the Element may operate for a stable power swing across the Element. (Note: The use of SPS has been replaced with Remedial Action Scheme (RAS) for consistency with a current project to revise the definition of “Special Protection System”). No change made.</p>
Austin Energy	No	<p>(1) City of Austin dba Austin Energy (AE) notes the following statement from the PSRPS technical document on page 20: “Based on its review of historical events, consideration of the trade-offs between dependability and security, and recognizing the indirect benefits of implementing the transmission relay loadability standard (PRC-023), the SPCS concludes that a NERC Reliability Standard to address relay performance during stable swings is not needed, and could result in unintended.”</p> <p>AE believes more background work is necessary in justifying the creation of this standard before proceeding.</p> <p>Response: Please see the section at the beginning of this document called, “NERC Discussion on Proceeding(s) and Directives Regarding: Stable Power Swings” for a complete background. The SDT understands that NERC staff re-engaged FERC staff following the completion of the PSRPS Report and that</p>



Organization	Yes or No	Question 1 Comment
		<p>the Commission still desired NERC to pursue its work to meet the directive. However, FERC staff was open to an approach designed by NERC. NERC staff has informally received positive feedback on the approach to address the regulatory directive. The directive itself was challenged by commenters prior to the issuance of Order No. 733 and was already the subject of multiple rehearing requests in the Order No. 733-A and Order No. 733-B proceedings. Similar arguments to the conclusions of the NERC System Protection and Control Subcommittee were advanced in these FERC proceedings.</p> <p>(2) Further, AE disagrees with the R2 criteria of evaluating Disturbance records “since January 1, 2003.” The criteria not only predate the enforcement date of this standard, it goes back to a time before any of the NERC Reliability Standards were enforceable.</p> <p>Response: The “January 1, 2003” date has been removed from the standard. Requirement R2 (and new R3) are based on actual Disturbances that occur after the Effective Date of the standard. Change made.</p>
Northeast Utilities	No	<p>We agree with a focused approach as outlined in the technical document. However, we have the following serious concerns with criteria in the requirements:</p> <p>1. The term “credible event” should be clearly defined. The basis to determine a credible event is missing from the requirement and application guide. This basis should be provided in the standard requirement.</p> <p>Response: The term “credible” has been removed from the standard. The drafting team clarified Requirement R1, Criterion 3 by framing the criterion in the present tense to refer to current assessment(s). The term “credible” was removed from the previous Requirement R2 (and new R3) because the required performance refers to only current actual events. Change made.</p> <p>2. Why is the standard focused on SOL rather than IROL? The basis for specifying SOL is not supported by the example in the application guideline since the example did not show inter-area impact.</p> <p>Response: Several commenters questioned the use of a System Operating Limit (SOL) to determine Elements that needed evaluation because they were not necessarily associated with wide-area problems. The drafting team contends that not only SOLs that have been shown to expose a widespread area to instability, uncontrolled separation(s) or cascading outages should be considered. Identified localized</p>

Organization	Yes or No	Question 1 Comment
		<p>instability issues also point to Elements that should reduce the likelihood of tripping for stable power swings. No change made.</p> <p>3. It is not clear in R1, criteria number 4 whether the assessment should include relay tripping or just stable power swing or both stable and unstable power swing.</p> <p>Response: Requirement R1 – Criterion 4, Requirement R2 – Criterion 1, and the new Requirement R3 – Criterion 1, were clarified by adding both “stable and unstable” power swings. Both stable and unstable power swings determine whether an Element will be identified as experiencing a power swing. Change made.</p> <p>4. In R2, it is unrealistic to require an entity to provide data on an Element that had tripped since 2003. There is no existing NERC continent-wide disturbance monitoring or misoperation standard that requires data be retained more than 12 months. We recommend that this requirement be removed from the standard or include only Elements that were tripped in the last calendar year.</p> <p>Response: The “January 1, 2003” date has been removed from the standard. Requirement R2 (and new R3) are based on actual Disturbances that occur after the Effective Date of the standard. Change made.</p>
Idaho Power Co.	No	<p>No. R1 seems to be an acceptable approach for Planners to use. However, R2 is not acceptable. Having a dated requirement prior to the effective date of a Standard is not appropriate. While it may be reasonable to look at these earlier disturbances, making a Requirement of that review is not. This requirement should be removed or rewritten to require only the review of disturbances past the effective date of the Standard where tripping of Protection Systems during a stable power swing was a causal factor.</p> <p>Response: The “January 1, 2003” date has been removed from the standard. Requirement R2 (and new R3) are based on actual Disturbances that occur after the Effective Date of the standard. Change made.</p> <p>In addition, the PSRPS technical document does not use the NERC Glossary term for Disturbances, yet the Standard does. The Glossary term is not specific which makes these criterion also non specific. Criterion similar to those in EOP-004 would seem to better identify the disturbances that are included in this</p>

Organization	Yes or No	Question 1 Comment
		<p><b>Standard.</b></p> <p>Response: The drafting team revised Requirement R1, Criterion 4 by changing “Disturbance” to “simulated disturbance” to comport with the approved Reliability Standard TPL-001-4. The use of “Disturbance” in Requirements R2 (TO) and new R3 (GO) relates to an actual system Disturbance. Change made.</p> <p>M2 appears to require the utility to have evidence it did not know it needed to maintain.</p> <p>Response: The “January 1, 2003” date has been removed from the standard. Requirement R2 (and new R3) are based on actual Disturbances that occur after the Effective Date of the standard; therefore, the Measure now only requires the entity to have evidence from the Effective Date forward. Change made.</p> <p>The PSRPS technical document suggests that the FERC directive to develop this standard may have been based on misinformation or a misunderstanding of the 2003 Northeast Blackout investigation report and furthermore suggests such a standard could result in unintended adverse impacts to the Bulk-Power System. Recommend NERC utilize the findings of the PSRPS technical document to obtain a stay of development of PRC-026-1 from FERC until FERC can develop a position based on the conclusions presented in the PSRSP document.</p> <p>Response: Please see the section at the beginning of this document called, “NERC Discussion on Proceeding(s) and Directives Regarding: Stable Power Swings” for a complete background. The SDT understands that NERC staff re-engaged FERC staff following the completion of the PSRPS Report and that the Commission still desired NERC to pursue its work to meet the directive. However, FERC staff was open to an approach designed by NERC. NERC staff has informally received positive feedback on the approach to address the regulatory directive. The directive itself was challenged by commenters prior to the issuance of Order No. 733 and was already the subject of multiple rehearing requests in the Order No. 733-A and Order No. 733-B proceedings. Similar arguments to the conclusions of the NERC System Protection and Control Subcommittee were advanced in these FERC proceedings.</p> <p>The NERC System Protection and Control Subcommittee (SPCS) concern is that an overly prescriptive standard as contemplated in Order No. 733 could lead to unintended adverse impacts. The focused</p>

Organization	Yes or No	Question 1 Comment
		<p>approach recommended by the SPCS, and implemented by the drafting team, addresses the concern by requiring entities implement Corrective Action Plans to improve security for stable power swings by meeting the criteria in PRC-026-1 – Attachment B while maintaining dependable fault detection and dependable out-of-step tripping. No change made.</p> <p>If development of PRC-026-1 continues: I agree with the focused approach.</p> <p>R1.1 and R1.2 need to contain clarity about what constitutes a "line out condition" - does this mean N-1, N-2, N-X, transformers, etc?</p> <p>Response: The phrase "line-out conditions" has been removed. Elements should be identified based on the Requirement R1 criterion regardless of the outage conditions that may be necessary to trigger enforcement of the System Operating Limit (SOL) or arming of the Special Protection System (SPS). The Guidelines and Technical Basis have been supplemented to provide additional information. (Note: The use of SPS has been replaced with Remedial Action Scheme (RAS) for consistency with a current project to revise the definition of "Special Protection System"). Change made.</p> <p>Concerning R1.3, who is the judge of whether an event is "credible"?</p> <p>Response: The term "credible" has been removed from the standard. The drafting team clarified Requirement R1, Criterion 3 by framing the criterion in the present tense to refer to the current assessment(s). Islands caused by natural phenomena (i.e., Disturbances) are covered under Requirement R2. Change made.</p>
Public Utility District No. 1 of Cowlitz County, WA	No	<p>Cowlitz PUD agrees with the intent of standard PRC-026-1 (Standard) requirements R1 &amp; R2 focused approach, but finds the current Standard draft creates a compliance difficulty. The Standard should clearly define the "specific criterion" which will be used to identify Elements, and compare the load-responsive protective relay characteristics to establish "credible" risk. The Standard lacks specificity as currently written.</p> <p>Response: The drafting team modified Requirement R1 to add clarity. For example, Criterion 1 – added "angular" to "stability constraint, Criterion 2 – "monitored" to identify which Element, Criterion 3 – to</p>

Organization	Yes or No	Question 1 Comment
		<p>include island boundaries due to angular instability within an underfrequency load shedding (UFLS) assessment, and Criterion 4 – that a “power swing” refers to both “stable” and “unstable.” Also, the Generator Owner was moved from Requirement R2 to the new Requirement R3 in order to remove the “islanding” criteria for Generator Owners.</p> <p>The term “credible” has been removed from the standard. The drafting team clarified Requirement R1, Criterion 3 by framing the criterion in the present tense to refer to current assessment(s). The term “credible” was removed from the previous Requirement R2 (and new R3) because the required performance refers to only current actual events. Change made.</p> <p>--(New Paragraph)—</p> <p>This draft assumes incorrectly that an entity will have retained operational historical records since 2003. If such records do not exist, an entity will have no proof of having established a null or complete list which satisfies requirement R2.</p> <p>Further, there is no requirement to retain such operational records to facilitate future compliance. The CEA must either accept attestations, or require applicable entities to develop documentation for each section 4.2 applicable Element which establishes no credible risk of a trip during a [stable] power swing exists. Cowlitz PUD proposes the SDT identify specific documentation and establish an official listing, such as all pertinent RE and NERC disturbance studies/reports dated 2003 or later be used to identify past poorly performing Elements during a Disturbance.</p> <p>Response: The “January 1, 2003” date has been removed from the standard. Requirement R2 (and new R3) are based on actual Disturbances that occur after the Effective Date of the standard. Change made.</p> <p>We are also unclear on how Elements might be identified purely from system modeling studies when strictly looking at Requirement R1 (ignoring R3 or other standard requirements outside of this Standard).</p> <p>Response: The drafting team has included ways for Elements to be identified other than through system modeling studies, but it contends that some Elements may be identified and included through that process. Requirement R1 – Criterion 4 is not requiring additional studies, but the identification of any</p>

Organization	Yes or No	Question 1 Comment
		<p>Element that was observed as tripping in the most recent Planning Assessment (i.e., TPL-001-4) would be included. No change made.</p> <p>Further, “credible” is a subjective term which does not establish a clear compliance line. It may be better to state “...actual system Disturbance where current system modeling continues to identify a repeat of the Disturbance possible under an n-3 event.” Another possible method would be to tie “credible” to a probability of one in a thousand; this method would require probability model development. This is not to say that “credible” should not be used, but it will require extensive guidance in the RSAW of how the “credible” benchmark is established. In fairness, the benchmark should be established during Standard development to allow stakeholder review and comment.</p> <p>Response: The term “credible” has been removed from the standard. The drafting team clarified Requirement R1, Criterion 3 by framing the criterion in the present tense to refer to the current assessment(s). Islands caused by natural phenomena (i.e., Disturbances) are covered under Requirement R2. Change made.</p>
PacifiCorp	Yes	<p>R1, which states “Any Element that is located or terminates at a generating plant, where a generating plant stability constraints exists and is addressed by an operating limit or a Special Protection System (SPS) (including line-out condition)” .... raises concerns. In WECC region, a SPS or RAS has to be redundant. Language needs to be added to make a redundant system an exemption from this requirement.</p> <p>Response: The drafting team contends that the Special Protection System (SPS) as stated in Requirement R1 is in place to prevent angular instability. The standard does not address a failing SPS, but is addressing the Elements associated with an SPS that would be susceptible to a power swing. (Note: The use of SPS has been replaced with Remedial Action Scheme (RAS) for consistency with a current project to revise the definition of “Special Protection System”). No change made.</p>
MRO NERC Standards Review Forum	Yes	

Organization	Yes or No	Question 1 Comment
Tennessee Valley Authority	Yes	
SPP Standards Review Group	Yes	<p>Establishing criteria that determine which Elements must be assessed according to Requirements R1 and R2 reduce the compliance burden on Generator Owners and Transmission Owners. This is the right approach. That said, we concur with AEP in that the SDT should limit the use of the term 'stability' in the standard to oscillatory and transient stability in order to avoid confusion with voltage and steady state stability.</p> <p>Response: The drafting team added "angular" to "stability constraint" to clarify the intent in Requirement R1, both Criterion 1 and 2. Change made.</p>
Southern Company; Southern Company Services, Inc.; Alabama Power Company; Georgia Power Company; Gulf Power Company; Mississippi Power Company; Southern Company Generation; Southern Company Generation and Energy Marketing	Yes	<p>Yes, in part. Addressing situations and occurrences of undesired relay operations is an appropriate method to minimize future undesired operations.</p> <p>The review period should be a rolling time period (previous 5 years) rather than &gt; 10 years ago, as many entities will not have historical records to validate potential mis-operations. Entities were not required to keep such records to the date specified in R1 and R2.</p> <p>Response: The "January 1, 2003" date has been removed from the standard. Requirement R2 (and new R3) are based on actual Disturbances that occur after the Effective Date of the standard.</p> <p>A fifth Criterion was added to Requirement R1 that requires the Planning Coordinator to continue identifying an Element "unless the Planning Coordinator determines the Element is no longer susceptible to power swings." This ensures visibility of the Elements reported by the Generator Owner or Transmission Owner on an ongoing basis since the Element tripped in response to a power swing. Change made.</p> <p>R1 #4 and R2 #1 should specify the inclusion of Elements that trip due to "stable power swings" instead of all power swings.</p> <p>Response: Requirement R1 – Criterion 4, Requirement R2 – Criterion 1, and the new Requirement R3 –</p>

Organization	Yes or No	Question 1 Comment
		<p>Criterion 1, were clarified by adding both “stable and unstable” power swings. Both stable and unstable power swings are included because both are indicators that load-responsive protective relays may be challenged by power swing conditions. Clarification made.</p>
<p>Dominion</p>	<p>Yes</p>	
<p>Florida Power &amp; Light</p>	<p>Yes</p>	<p>The language for Criteria 3 &amp; 4 in Requirement 1 should be modified.</p> <p>Criteria 3 should consider underfrequency planning simulations in addition to angular stability planning simulations.</p> <p>Response: The drafting team modified Requirement R1, Criterion 3 to include island boundaries due to angular instability within an underfrequency load shedding (UFLS) assessment. Also, the Generator Owner was moved from Requirement R2 to the new Requirement R3 in order to remove the “islanding” criteria for Generator Owners. Change made.</p> <p>Criteria 4 should consider Planning Assessments in the last year as opposed to “the most recent Planning Assessment.”</p> <p>Response: The drafting team asserts that the most recent Planning Assessment provides a concrete reference to the information used in identifying BES Elements. Since the Planning Assessments (i.e., TPL-001-4) are performed annually, any other description would create confusion as to whether an entity should use past information or information revealed during preparation of a Planning Assessment. No change made.</p>
<p>PPL NERC Registered Affiliates</p>	<p>Yes</p>	<p>These comments are submitted on behalf of the following PPL NERC Registered Affiliates: LG&amp;E and KU Energy, LLC; PPL Electric Utilities Corporation, PPL EnergyPlus, LLC; PPL Generation, LLC; PPL Susquehanna, LLC; and PPL Montana, LLC. The PPL NERC Registered Affiliates are registered in six regions (MRO, NPCC, RFC, SERC, SPP, and WECC) for one or more of the following NERC functions: BA, DP, GO, GOP, IA, LSE, PA, PSE, RP, TO, TOP, TP, and TS Comments:</p>



Organization	Yes or No	Question 1 Comment
		<p>We agree with the general approach, but have some implementation concerns as expressed below.</p> <p>Response: Thank you for your comment.</p>
<p>Arizona Public Service Co.</p>	<p>Yes</p>	<p>While AZPS agrees with the focused approach, AZPS would like to ask the drafting team to consider revising R1 and R2. APS recommends that the drafting team require an initial identification and notification of each Element that meets the criteria described in R1. A review of the assessment should not be required annually if there are no additions to the entity system meeting the criteria. It would be more practical to require a comprehensive review every five years.</p> <p>In addition, the standard should require that if Elements are added to the entity system that meet the criteria in R1, the applicable entity should provide updates within 90 days of the commissioning of a new Element.</p> <p>Response: The drafting team increased the Implementation Plan to three years to provide for the initial influx of identified Elements under Requirement R1. The evaluation of relays under Requirement R4 (previously R3) is to be performed “within 12 full calendar months of receiving notification of an Element ... where the evaluation has not been performed in the last three calendar years.” Change made.</p> <p>APS believes that the current draft requirement is administrative in nature and represents a reporting burden.</p> <p>Response: The drafting asserts that notifying the other entities is not administrative and provides a reliability necessity to communicate the BES Elements that meet the defined criteria or Elements that have experienced an actual stable or unstable power swing. No change made.</p>
<p>Bureau of Reclamation</p>	<p>Yes</p>	
<p>Peak Reliability</p>	<p>Yes</p>	

Organization	Yes or No	Question 1 Comment
American Electric Power	Yes	<p>We agree with the focused approach. We would recommend qualifying the term “stability,” in R1.2 in particular, as “transient or oscillatory stability” so that voltage or steady-state stability, which would not cause power swings, are not mistakenly construed by an auditor. TPL-001-4 permits use of generic relay models in dynamic simulation planning studies, so the reference in R1.4 to relay tripping in planning assessments may not end up being based on the relays actually installed.</p> <p>Response: The drafting team added “angular” to “stability constraint” to clarify the intent in Requirement R1, both Criterion 1 and 2. Change made.</p>
American Transmission Company, LLC	Yes	
Manitoba Hydro	Yes	
Exelon	Yes	
Texas Reliability Entity	Yes	
ITC	Yes	<p>In general we agree. However, the SDT should clarify what constitutes an island with regard to this standard as it’s not a defined term. Should this standard pertain to lines which contain both generation and load, which when tripped form an island? We suggest not.</p> <p>Response: The drafting team modified Requirement R1, Criterion 3 to include island boundaries due to angular instability within an underfrequency load shedding (UFLS) assessment. Also, the Generator Owner was moved from Requirement R2 to the new Requirement R3 in order to remove the “islanding” criteria for Generator Owners. Change made.</p> <p>Also, the term “credible” is unclear. If an event involves scenarios beyond TPL’s “broad spectrum of</p>

Organization	Yes or No	Question 1 Comment
		<p>System conditions” and “wide range of probably Contingencies”, is it really credible? The example in Application Guideline involved a single bus outage, which is credible in TPL standards. However, a Disturbance may occur involving multiple contingencies but well beyond normal planning criteria and now that e`xtreme event must be studied. If this approach is desired, then it leaves a gap for other extreme events to occur, just which we’ve had the good fortune not to have experienced yet. We suggest limiting the definition of “credible” into include those scenarios within the bounds of TPL-001-4.</p> <p>Response: The term “credible” has been removed from the standard. The drafting team clarified Requirement R1, Criterion 3 by framing the criterion in the present tense to refer to the current assessment(s). Islands caused by natural phenomena (i.e., Disturbances) are covered under Requirement R2. Change made.</p>
Southern California Edison Company	Yes	
Salt River Project	Yes	
DTE Electric		No comment
Xcel Energy	Yes	<p>The frequency of performing the tasks within these requirements is unnecessarily aggressive; power systems dynamics do not change that fast. We should recommend changing the frequency to every 3 to 4 years.</p> <p>Response: The drafting team increased the Implementation Plan to three years to provide for the initial influx of identified Elements under Requirement R1. The evaluation of relays under Requirement R4 (previously R3) is to be performed “within 12 full calendar months of receiving notification of an Element ... where the evaluation has not been performed in the last three calendar years.” Change made.</p>

- Do you agree that the Planning Coordinator, Reliability Coordinator, and Transmission Planner are the appropriate entities to identify the Elements that meet the criteria in Requirement R1? If not, please explain why an entity is not appropriate and/or suggest an alternative that should identify the Elements according to the criteria

Summary Consideration: About two-thirds of the commenters for Question 2 agreed with the proposed applicable entities; however, the drafting team did remove two of the applicable entities as noted here. There were three primary concerns in this area all of which resulted in a revision to the standard. The chief issue was the use of a historical date (January 1, 2003) in the Requirements. The intent of this language was to provide a “current day look” back into history concerning Disturbances. The historical information would then be used to assess Elements and/or relays concerning power swings. This concern was raised in 34 comments supported by 144 stakeholders. To address the concern, this reference was removed and all of the associated requirements and criteria have been worded in the present tense to make clear that that no historical review is being required. Seventeen comments from 75 individuals raised varying issues about having the Planning Coordinator, Reliability Coordinator, and the Transmission Planner all identifying Elements pursuant to Requirement R1. The comments were considered and it was determined that the Planning Coordinator should be designated as a single entity source of identifying Elements. The reasoning is that the Planning Coordinator has or has access to the knowledge including the wide-area view and having a single entity will avoid duplication and potential gaps should multiple entities believe the other is identifying Elements. Last, 8 comments from 24 stakeholders argued that one month at the beginning of each calendar year for notifying the respective Generator Owner and Transmission Owner is onerous. Although the idea was to keep activities synchronized on an annual basis, the drafting team understood the concerns; therefore, the Requirement R1 language about “January of each calendar” has been removed and replaced with “each calendar year.” This revision was based on comment and on time period changes in other Requirements and determined to be more appropriate.

Organization	Yes or No	Question 2 Comment
SMUD/BANC	No	<p>Collected data and subsequent analysis has not identified tripping during stable power swings. This phenomenon is rare if at all. Any tripping during stable power swings would more appropriately included as a mis-operation and addressed as such.</p> <p>Response: Tripping for stable power swings were observed in the August 14, 2003 Blackout.<sup>6</sup> Misoperation standard is a reactive standard and PRC-026-1 is a proactive standard aiming to prevent load-responsive protective relay operations for stable power swings. This standard is different from the</p>

<sup>6</sup> <http://www.nerc.com/pa/rrm/ea/Pages/Blackout-August-2003.aspx>

Organization	Yes or No	Question 2 Comment
		<p>Misoperations standard because it requires notification to the Planning Coordinator of Elements that have tripped due to stable or unstable power swings.</p> <p>Response: Please see the section at the beginning of this document called, “NERC Discussion on Proceeding(s) and Directives Regarding: Stable Power Swings” for a complete background. The SDT understands that NERC staff re-engaged FERC staff following the completion of the PSRPS Report and that the Commission still desired NERC to pursue its work to meet the directive. However, FERC staff was open to an approach designed by NERC. NERC staff has informally received positive feedback on the approach to address the regulatory directive. The directive itself was challenged by commenters prior to the issuance of Order No. 733 and was already the subject of multiple rehearing requests in the Order No. 733-A and Order No. 733-B proceedings. Similar arguments to the conclusions of the NERC System Protection and Control Subcommittee were advanced in these FERC proceedings.</p> <p>This comment is the same as SMUD/BANC, Question 1, #1. See response in Question 1.</p>
SPP Standards Review Group	No	<p>The Reliability Coordinator may not be aware of Elements identified in Criteria 3 and 4, since that knowledge is based upon the Planning Coordinator or the Transmission Planner notifying the Reliability Coordinator of the situation. Yet the Reliability Coordinator is held accountable for the identification and notification ‘...of each Element that meets one or more...’ of the criteria. Similarly, there may be situations where the Planning Coordinator or Transmission Planner may not be aware of Elements identified by the Reliability Coordinator yet they are also held accountable for identification and notification of each Element. There should be one, single list of all the Elements that satisfy the criteria but the responsible entities may not, individually, reach the same conclusions regarding the make-up of that list. Their individual lists may not contain all the Elements to be identified but a composite of all their lists should result in the one, true list of all Elements. The requirement needs to be modified to include this consideration.</p> <p>Response: The Reliability Coordinator and Transmission Planner have been removed from the standard’s Applicability; therefore, Requirement R1 is now only applicable to the Planning Coordinator as a single entity source of identifying Elements. The drafting team asserts that the Planning Coordinator has or has</p>

Organization	Yes or No	Question 2 Comment
		<p>access to the knowledge including the wide-area view. Change made to the Requirement.</p>
<p>ISO RTO Council Standards Review Committee</p>	<p>No</p>	<p>These three entities are appropriate for the R1 requirement. However, there should be a requirement that only one of the three is deemed responsible to provide notice to the facility owner. Every facility that falls under the R1 criteria is under the authority of all three entities. It would be repetitious and redundant to require all three entities to provide the same information to the same facility owner.</p> <p>However, if the intent of the requirement is that the Reliability Coordinator will address the Operations Planning Horizon, while the Planning Coordinator and Transmission Planner will address the Long-Term Planning Horizon, then it may not be repetitious nor redundant to require these entities to address Requirement R1. Also, the entity who is registered as the RC may differ from the entity who is registered as the PC and TP. For example, in the Western Interconnection, Peak Reliability is the RC, the CAISO is the PC for much of California (but not all), and the Participating Transmission Owners are registered as the TP. In CAISO's case, the three registered entities of RC, PC, and TP are represented by different entities.</p> <p>Response: The Reliability Coordinator and Transmission Planner have been removed from the standard's Applicability; therefore, Requirement R1 is now only applicable to the Planning Coordinator as a single entity source of identifying Elements. The drafting team asserts that the Planning Coordinator has or has access to the knowledge including the wide-area view. Change made to the Requirement.</p>
<p>ACES Standards Collaborators</p>	<p>No</p>	<p>We do not believe that the Transmission Planner should be an applicable entity. Any studies completed by the TP will be duplicated in a larger PC study thus making the inclusion of the TP unnecessary.</p> <p>Response: The Reliability Coordinator and Transmission Planner have been removed from the standard's Applicability; therefore, Requirement R1 is now only applicable to the Planning Coordinator as a single entity source of identifying Elements. The drafting team asserts that the Planning Coordinator has or has access to the knowledge including the wide-area view. Change made to the Requirement.</p>
<p>Duke Energy</p>	<p>No</p>	<p>Duke Energy disagrees with the applicability of the Reliability Coordinator (RC) to Requirement R1. From a NERC Reliability Functional Model standpoint, the RC does not directly interface with a Generator Owner</p>

Organization	Yes or No	Question 2 Comment
		<p>(GO) or Transmission Owner (TO) as Requirement R1 is proposing. The RC receives facility and operational data such as maintenance plans from TOs and GOs for reliability analysis, but this is mostly done through automation i.e. SDX (System Data Exchange). The Functional Model even states that the RC coordinates with other RCs, Transmission Planners, and Transmission Service Providers on transmission system limitations, not to TOs or GOs. Communication from an RC is most always directed to the Balancing Authority (BA) or Transmission Operator (TOP), and the RC reliability analyses is provided to TOPs, BAs and Generator Operators in its area as well as other RCs. An RC, per FAC-011, is required to establish a methodology for the identification of SOLs/IROLs and communicate the methodology to the TOP. RCs assist TOPs in calculating and coordinating SOLs, but the TOP is the Functional Entity that implements the RC methodology to identify and communicate the SOLs/IROLs to its RC in the Operations Horizon.</p> <p>Lastly, we feel that this standard would create a precedent requiring the RC to unnecessarily communicate and interface with GOs and TOs; an action that is not required by the current enforceable Reliability Standards. We recommend that the TOP should supplant the RC as the applicable entity responsible for communicating the criterion list in the proposed PRC-026-1 Requirement R1. Duke Energy proposes the following alternative language for Requirement R1.</p> <p style="padding-left: 40px;">"Each Planning Coordinator, Transmission Operator, and Transmission Planner shall, within the first month of each calendar year, identify and provide notification to its Reliability Coordinator, and to the respective Generator Owner and Transmission Owner of each Element that meets one or more of the following criteria, if any:"</p> <p>Response: The Reliability Coordinator and Transmission Planner have been removed from the standard's Applicability; therefore, Requirement R1 is now only applicable to the Planning Coordinator as a single entity source of identifying Elements. The drafting team asserts that the Planning Coordinator has or has access to the knowledge including the wide-area view. Change made to the Requirement.</p>
BC Hydro	No	<p>BC Hydro does not agree that the criteria of R1 are reasonable. Therefore cannot suggest why an entity is not appropriate.</p> <p>Response: The drafting team asserts that it has implemented the recommended approach provided in the</p>

Organization	Yes or No	Question 2 Comment
		NERC System Protection and Control Subcommittee (SPCS) technical report, <i>Protection System Response to Power Swings</i> , August 2013 <sup>7</sup> (PSRPS Report). No change made.
Florida Municipal Power Agency	No	<p>Unless there is a requirement somewhere in the standards for Reliability Coordinators to perform stability analyses (there currently is not, SOLs/IROLs are studied by the TOP in accordance with the RC's methodology); then, this requirement would cause all RCs to have to perform stability studies.</p> <p>Response: The Reliability Coordinator and Transmission Planner have been removed from the standard's Applicability; therefore, Requirement R1 is now only applicable to the Planning Coordinator as a single entity source of identifying Elements. The drafting team asserts that the Planning Coordinator has or has access to the knowledge including the wide-area view. Change made to the Requirement.</p> <p>Also, "corrective action plans" for protection systems will more likely be a planning horizon activity (e.g., changing out relays) and hence, the studies should be planning horizon studies, not operating horizon studies and the RC should not be included.</p> <p>Response: The time period for Requirement R4 (previously R3) has been changed to be within twelve full calendar months of notification of the Elements pursuant to Requirement R1. Requirement R4 (previous R3) and new R5 are applicable to the Generator Owner and Transmission Owner. The Reliability Coordinator has been removed from the applicability of the standard.. Change made.</p> <p>Response: The "Operations Planning" time horizon for Requirement R6 (previously R4) regarding the implementation of the Corrective Action Plan (CAP) was eliminated, leaving the "Long-term Planning" time horizon. Change made.</p>
Bonneville Power Administration	No	BPA feels the Standard needs to delineate which entity performs which role, and under which conditions. For example, the Reliability Coordinator (RC) only identifies the Elements tripped during islanding and disturbance, while the Planning Coordinator (PC) and Transmission Planner (TP) do so for long term

<sup>7</sup> NERC System Protection and Control Subcommittee, *Protection System Response to Power Swings*, August 2013: [http://www.nerc.com/comm/PC/System%20Protection%20and%20Control%20Subcommittee%20SPCS%2020/SPCS%20Power%20Swing%20Report\\_Final\\_20131015.pdf](http://www.nerc.com/comm/PC/System%20Protection%20and%20Control%20Subcommittee%20SPCS%2020/SPCS%20Power%20Swing%20Report_Final_20131015.pdf)



Organization	Yes or No	Question 2 Comment
		<p>planning.</p> <p>Response: The Reliability Coordinator and Transmission Planner have been removed from the standard's Applicability; therefore, Requirement R1 is now only applicable to the Planning Coordinator as a single entity source of identifying Elements. The drafting team asserts that the Planning Coordinator has or has access to the knowledge including the wide-area view. Change made to the Requirement.</p>
Public Service Enterprise Group	No	<p>We disagree with the need for this standard.</p> <p>Response: Thank you for your comment. Please see response in Question 1 above.</p>
Peak Reliability	No	<p>The TP's relationship to the PC is synonymous with the TOP's relationship with the RC, so leaving the TOP out as an applicable entity creates a reliability gap. The TOP is responsible for establishing SOLs.</p> <p>Response: The Reliability Coordinator and Transmission Planner have been removed from the standard's Applicability; therefore, Requirement R1 is now only applicable to the Planning Coordinator as a single entity source of identifying Elements. The drafting team asserts that the Planning Coordinator has or has access to the knowledge including the wide-area view. Change made to the Requirement.</p> <p>The drafting team contends that a System Operating Limit (SOL) as stated in Requirement R1 is in place to prevent angular instability. The standard addresses Elements associated with an SOL as an Element that would be susceptible to a power swing. No change made.</p>
Electric Reliability Council of Texas, Inc.	No	<p>See our comments to Q1.</p> <p>Response: Thank you for your comment. Please see response in Question 1 above.</p>
Tacoma Power	No	<p>See Tacoma Power's response to Question 9. At least in WECC, not all of these entities may be appropriate to lead the identification effort.</p> <p>Response: Thank you for your comment. Please see response in Question 9 below.</p>

Organization	Yes or No	Question 2 Comment
Ameren	No	<p>We believe that even if these are the right entities, it is unclear who is driving the identification process or if they even agree. Please change to 'Each Transmission Planner with the Planning Coordinator's and Reliability Coordinator's concurrence shall, within the first month of each calendar year, identify and provide notification to the respective Generator Owner and Transmission Owner of each Element that meets one or more of the following criteria...' In most cases, we believe the TP would identify these with their studies and therefore should take the lead.</p> <p>Response: The Reliability Coordinator and Transmission Planner have been removed from the standard's Applicability; therefore, Requirement R1 is now only applicable to the Planning Coordinator as a single entity source of identifying Elements. The drafting team asserts that the Planning Coordinator has or has access to the knowledge including the wide-area view. Change made to the Requirement.</p> <p>The Requirement R1 language about "January of each calendar" has been removed and replaced with "each calendar year." Based on time period changes in other Requirements, the drafting team determined that an annual periodicity in Requirement R1 is more appropriate. Change made.</p>
Public Utility District No. 1 of Cowlitz County, WA	No	<p>Cowlitz PUD questions whether the Transmission Planner (TP) is nothing more than an extension of the Transmission Owner (TO), Generation Owner (GO), or Planning Coordinator (PC) registrations. Further, we believe the majority of those entities registered as a TP consider their TP footprint equal to their TO/GO/PC footprint. Therefore, it may be more appropriate for the TP to simply report Requirement R1 findings to the PC and RC.</p> <p>Finally, we believe it more efficient that a single entity be responsible to give notice to the TO and GO. Since every TO and GO must be under a Planning Coordinator and Reliability Coordinator, either the PC or the RC should be designated to send out the notice after their review is complete.</p> <p>Response: The Reliability Coordinator and Transmission Planner have been removed from the standard's Applicability; therefore, Requirement R1 is now only applicable to the Planning Coordinator as a single entity source of identifying Elements. The drafting team asserts that the Planning Coordinator has or has access to the knowledge including the wide-area view. Change made to the Requirement.</p>

Organization	Yes or No	Question 2 Comment
PacifiCorp	Yes	
MRO NERC Standards Review Forum	Yes	
Tennessee Valley Authority	Yes	
Southern Company; Southern Company Services, Inc.; Alabama Power Company; Georgia Power Company; Gulf Power Company; Mississippi Power Company; Southern Company Generation; Southern Company Generation and Energy Marketing	Yes	<p>The PC, RC and TP, or some combination is the appropriate entity to identify elements that meet the criteria in Requirement R1. R1 should allow collaboration between the PC, RC and TP to produce a single list of Elements that will satisfy compliance for all three entities.</p> <p><i>Response: The Reliability Coordinator and Transmission Planner have been removed from the standard's Applicability; therefore, Requirement R1 is now only applicable to the Planning Coordinator as a single entity source of identifying Elements. The drafting team asserts that the Planning Coordinator has or has access to the knowledge including the wide-area view. Change made to the Requirement.</i></p>
Dominion	Yes	
FirstEnergy Corp.	Yes	

Organization	Yes or No	Question 2 Comment
Florida Power & Light	Yes	
PPL NERC Registered Affiliates	Yes	
DTE Electric	Yes	
Puget Sound Energy	Yes	
Arizona Public Service Co.	Yes	
Bureau of Reclamation	Yes	
Luminant Generation Company LLC	Yes	
Ingleside Cogeneration LP	Yes	
Los Angeles Department of Water and Power	Yes	
Massachusetts	Yes	

Organization	Yes or No	Question 2 Comment
Attorney General		
MidAmerican Energy Company	Yes	
Consolidated Edison, Inc.	Yes	
American Transmission Company, LLC	Yes	
Manitoba Hydro	Yes	
Independent Electricity System Operator	Yes	
David Kiguel	Yes	
ISO New England	Yes	
Exelon	Yes	
New York Power Authority	Yes	<p>The Planning Coordinator, Reliability Coordinator, and Transmission Planner would have the necessary data and capabilities to perform such functions for internal control areas and interregional ties.</p> <p>Response: The Reliability Coordinator and Transmission Planner have been removed from the standard's Applicability; therefore, Requirement R1 is now only applicable to the Planning Coordinator as a single entity source of identifying Elements. The drafting team asserts that the Planning Coordinator has or has</p>

Organization	Yes or No	Question 2 Comment
		access to the knowledge including the wide-area view. Change made to the Requirement.
Oncor Electric Delivery LLC	Yes	<p>Oncor agrees that the three registered functions defined are those that should identify the elements in R1; however, if each criterion, except for criteria 4 as it would clearly come from the Transmission Planner, is assigned to a registered entity it would provide a more clear process.</p> <p>Response: The Reliability Coordinator and Transmission Planner have been removed from the standard's Applicability; therefore, Requirement R1 is now only applicable to the Planning Coordinator as a single entity source of identifying Elements. The drafting team asserts that the Planning Coordinator has or has access to the knowledge including the wide-area view. Change made to the Requirement.</p> <p>Additionally, R1 calls for "within the first month of each calendar year, identify and provide notification to the respective Generator Owner and Transmission Owner of each Element that meets one or more of the following criteria, if any" and then looking at criteria 1 and 2, Oncor recommends the SDT clarify the time frame, either real time/short term or future/long term, required. The Time Horizon does state "Long-term Planning" but it also calls for identification of the element within the first month of the calendar year. This would assist with whether or not planning data, which is done one year out, would be valid. See "line out condition" statement in Oncor's response to #6.</p> <p>Response: The Reliability Coordinator and Transmission Planner have been removed from the standard's Applicability; therefore, Requirement R1 is now only applicable to the Planning Coordinator as a single entity source of identifying Elements. The drafting team asserts that the Planning Coordinator has or has access to the knowledge including the wide-area view. Change made to the Requirement.</p> <p>The Requirement R1 language about "January of each calendar" has been removed and replaced with "each calendar year." Based on time period changes in other Requirements, the drafting team determined that an annual periodicity in Requirement R1 is more appropriate. Change made.</p>
Texas Reliability Entity	Yes	A TOP may also provide an analyses in the Operations horizon that could identify other lines pursuant to the PSRSP technical document. Has the SDT considered the inclusion of TOP in the applicability?

Organization	Yes or No	Question 2 Comment
		<p>Response: The Reliability Coordinator and Transmission Planner have been removed from the standard's Applicability; therefore, Requirement R1 is now only applicable to the Planning Coordinator as a single entity source of identifying Elements. The drafting team asserts that the Planning Coordinator has or has access to the knowledge including the wide-area view. The Planning Coordinator is believed to be the best single-source of information and not the Transmission Operator. Change made.</p> <p>The requirement as written implies that both the identification and notification of Elements must both be accomplished in January of each year. Identification can happen anytime each year, but notification must occur annually by January 31 each year. Suggest "Each year, each Planning Coordinator, Reliability Coordinator, and Transmission Planner shall identify, and by January 31 of each calendar year, provide notification..."</p> <p>Response: The Requirement R1 language about "January of each calendar" has been removed and replaced with "each calendar year." Based on time period changes in other Requirements, the drafting team determined that an annual periodicity in Requirement R1 is more appropriate. Change made.</p>
Northeast Utilities	Yes	
Idaho Power Co.	Yes	<p>Yes, although I suggest adding the stipulation that the PC, RC, and TP must be in agreement about whether an Element meets the criteria in R1.</p> <p>Response: The Reliability Coordinator and Transmission Planner have been removed from the standard's Applicability; therefore, Requirement R1 is now only applicable to the Planning Coordinator as a single entity source of identifying Elements. The drafting team asserts that the Planning Coordinator has or has access to the knowledge including the wide-area view. Change made to the Requirement.</p>
Southern California Edison Company	Yes	
Salt River Project	Yes	

Organization	Yes or No	Question 2 Comment
Xcel Energy	Yes	<p>We should recommend changing the frequency to every 3 to 4 years and changing the window to 3 to 6 months. It is troubling that the criteria (#4 in special) suggest that software used by planners should include detailed relay model. If approved, this will be huge work load for system protection engineering (SPE) and the planning department.</p> <p>Response: The Requirement R1 language about “January of each calendar” has been removed and replaced with “each calendar year.” Based on time period changes in other Requirements, the drafting team determined that an annual periodicity in Requirement R1 is more appropriate. Change made.</p> <p>The drafting team asserts that the standard does not require the inclusion of relay models. Requirement R1 – Criterion 4 is not requiring a study, but the identification of any Element that was observed as tripping in the most recent Planning Assessment pursuant to TPL-001-4, Requirement R4, Part 4.3.1.3 – “Tripping of Transmission lines and transformers where transient swings cause Protection System operation based on generic or actual relay models” which will become effective January 1, 2015 (U.S.). Other clarifying changes were made to Requirement R1 – Criterion 4.</p>



- Do you agree that the Generator Owner and Transmission Owner are the appropriate entities to identify the Elements that meet the criteria in Requirement R2? If not, please explain why an entity is not appropriate and/or suggest an alternative that should identify the Elements according to the criteria.

Summary Consideration: This section was evenly split between comments as to whether or not the Generator Owner and Transmission Owner are the appropriate entities to identify the Elements that meet the criteria in Requirement R2. Of the comments, there were two primary concerns not addressed in previous sections, one which resulted in a revision to the standard and the other no revision.

There were five comments by 18 stakeholders that were concerned about how the Generator Owner (GO) and Transmission Owner (TO) in Requirement R2 (now split between R2-TO and R3-GO) are to manage the record keeping for identified Elements as a result of a trip due to an actual power swing related Disturbance. In order to address this main concern, Requirement R2 (and the new R3) was modified to require the GO and TO to report any identified Elements to the Planning Coordinator. These Requirements allow the Planning Coordinator to be the sole source of channeling the “identified Elements” back to the GO and TO each year; therefore, a fifth Criterion was added to Requirement R1 that requires the Planning Coordinator (PC) to continue identifying a reported Element unless it determines the Element is no longer susceptible to power swings. This ensures visibility of the Elements reported by the GO or TO on an ongoing basis because the Element tripped in response to a power swing.

No change was made based on three comments by 34 individuals that the Generator Owner and Transmission Owners are not the most appropriate entities to evaluate load-responsive protective relay operations due to power swings. The drafting team contends that the Protection System owner (i.e., Generator Owner and Transmission Owner) is the appropriate entity for reviewing operations.

Organization	Yes or No	Question 3 Comment
Northeast Power Coordinating Council	No	<p>Requirement R2 requires GOs and TOs to evaluate Disturbance records “since January 1, 2003,” a time that will precede the effective date of this standard. A requirement CANNOT RELY UPON RECORDS THAT PRECEDE THE EFFECTIVE DATE OF A STANDARD. As an example, PRC-005-1, which was approved in Order 693, became effective on June 11, 2007, does not require a Registered Entity to have maintenance records available for the period of time that preceded the effective date in order to calculate the next maintenance interval for a relay. We recommend that this requirement be removed from the standard or include only Elements that were tripped in the last calendar year.</p> <p><a href="#">Response: The “January 1, 2003” date has been removed from the standard. Requirement R2 (and new</a></p>

Organization	Yes or No	Question 3 Comment
		R3) are based on actual Disturbances that occur after the Effective Date of the standard. Change made.
PacifiCorp	No	<p>These functions would be more appropriate assigned to the GOP and TOP.</p> <p>Response: The drafting team contends that the Protection System owner (i.e., Generator Owner and Transmission Owner) is the appropriate entity for reviewing operations. No change made.</p>
SMUD/BANC	No	<p>The requirement R2 is particularly unacceptable as it requires data for pre June 18, 2007; effective date of Order 693 standards.</p> <p>Response: The "January 1, 2003" date has been removed from the standard. Requirement R2 (and new R3) are based on actual Disturbances that occur after the Effective Date of the standard. Change made.</p>
<p>Southern Company;                      Southern Company Services, Inc.;                      Alabama Power Company;                      Georgia Power Company;                      Gulf Power Company;                      Mississippi Power Company;                      Southern Company Generation;                      Southern Company Generation and Energy Marketing</p>	No	<p>The TOs and GOs are the owners of the protection systems whose operation is being addressed, but the GO does not have a system view of stable power swings.</p> <p>Response: The Generator Owner (GO) in Requirement R3 and Transmission Owner (GO) in Requirement R2 are required to report the Element that tripped during a Disturbance in response to a power swing. These Requirements allow the Planning Coordinator to be the sole source of funneling the "identified Elements" to the GO and TO. A fifth Criterion was added to Requirement R1 that requires the Planning Coordinator (PC) to continue identifying an Element "unless the PC determines the Element is no longer susceptible to power swings." This ensures visibility of the Elements reported by the GO or TO on an ongoing basis since the Element tripped in response to a power swing.</p> <p>Based on this comment and other comments, the Generator Owner was moved from Requirement R2 to the new Requirement R3 in order to remove the "islanding" criteria for Generator Owners. Change made.</p> <p>Requiring the GO and TO to look back to 2003 every year as specified by R2 is unreasonable. Looking backwards to consider problems known to have occurred is understandable, but requiring this every year is not reasonable. These trip investigations have been occurring in the industry long before the mandated PRC-004 operation reviews. Most responsible utilities have addressed undesirable protection system</p>

Organization	Yes or No	Question 3 Comment
		<p>misoperations to maximize availability - the market forces have long driven utilities to correct undesirable relay operations so they can be available to the market.</p> <p>Response: The "January 1, 2003" date has been removed from the standard. Requirement R2 (and new R3) are based on actual Disturbances that occur after the Effective Date of the standard. Change made.</p>
<p>ISO RTO Council Standards Review Committee</p>	<p>No</p>	<p>We ask whether the TO or GO, especially a GO, will have access to studies and fault analysis reports that will determine if the Disturbance remains credible. There seems to be an assumption in R2 that a fault analysis study was performed that documents the Disturbance and system conditions at the time. There must be a requirement in some NERC standard that obligates appropriate entities are notified of these results.</p> <p>Response: The term "credible" has been removed from the standard. The drafting team clarified Requirement R1, Criterion 3 by framing the criterion in the present tense to refer to the current assessment(s). Islands caused by natural phenomena (i.e., Disturbances) are covered under Requirement R2. Change made.</p> <p>We are unclear on the relevance or need to trace back to 2003 for Disturbances that caused an Element to trip due to a power swing or which formed the boundary of an island. Further, the term credible Disturbance needs clarification. Please see our comment under Q1, above.</p> <p>Response: The Generator Owner (GO) in Requirement R3 and Transmission Owner (GO) in Requirement R2 are required to report the Element that tripped during a Disturbance in response to a power swing. These Requirements allow the Planning Coordinator to be the sole source of funneling the "identified Elements" to the GO and TO. A fifth Criterion was added to Requirement R1 that requires the Planning Coordinator (PC) to continue identifying an Element "unless the PC determines the Element is no longer susceptible to power swings." This ensures visibility of the Elements reported by the GO or TO on an ongoing basis since the Element tripped in response to a power swing. Change made.</p> <p>This requirement should not be written with a date specific start point. Over time, this date would be meaningless and inappropriate for applying the standard. Instead this requirement could be written in a</p>

Organization	Yes or No	Question 3 Comment
		<p>rolling calendar basis, e.g. - "prior twelve months".</p> <p>Response: The "January 1, 2003" date has been removed from the standard. Requirement R2 (and new R3) are based on actual Disturbances that occur after the Effective Date of the standard. Change made.</p>
<p>ACES Standards Collaborators</p>	<p>No</p>	<p>(1) We do not believe the GO or TO are appropriate entities. In fact, we do not believe any entity is appropriate to identify the Elements in R2 and that the requirements are not enforceable as written. NERC cannot compel evidence from dates prior to June 18, 2007, which is when FERC approved the first set of reliability standards. Furthermore, a new standard cannot compel data and evidence from before a time period that the standard was in effect. In today's litigious society, many companies have data retention programs that result in the destruction of data that is not required to be retained. Thus, GOs and TOs may not have the data. How would they comply? We simply will never be able to support a standard requiring data retroactively.</p> <p>(2) The topology of the transmission system has changed significantly in many areas since the January 1, 2003. That is over 11 years from the drafting of the standard. It is simply unreasonable to assume that power swings that occurred in 2003 would occur in the same way and that the data is still applicable. Relying on 11-year old data simply does not provide a sound engineering basis.</p> <p>Response: The "January 1, 2003" date has been removed from the standard. Requirement R2 (and new R3) are based on actual Disturbances that occur after the Effective Date of the standard. Change made.</p> <p>(3) The islanding analysis conducted for PRC-006-1 R1 would form a better basis for identifying these Elements and could be used in place of this requirement. The PC could notify the TO and GO of the Elements at the boundaries of the islands and R2 could then be removed avoiding the issue of retroactive compliance.</p> <p>Response: The drafting team modified Requirement R1, Criterion 3 – to include island boundaries due to angular instability within an underfrequency load shedding (UFLS) assessment (i.e., PRC-006), and moved the Generator Owner to the new Requirement R3 in order to remove the "islanding" criteria for Generator Owners. Change made.</p>

Organization	Yes or No	Question 3 Comment
FirstEnergy Corp.	No	<p>It is understood that the "... since January 1, 2003" verbiage is intended to capture applicable relay operations during the Aug. 14, 2003 event. It will be difficult if not nearly impossible for a GO, especially in a deregulated environment, to piece together details of relay operations prior to record-keeping requirements for NERC PRC-004. We recommend that these Criteria be reworded to include only incidents which have occurred since the inception of NERC PRC-004.</p> <p>Response: The "January 1, 2003" date has been removed from the standard. Requirement R2 (and new R3) are based on actual Disturbances that occur after the Effective Date of the standard. Change made.</p>
PPL NERC Registered Affiliates	No	<p>We agree with R2 in principle, but there are presently some barriers to the specified stand-alone nature of GO and TO obligations:</p> <ul style="list-style-type: none"> <li>- R2 should state that, where Elements meet one or more of criteria 1-4, the TO must provide GOs with the system impedance data necessary to perform their studies (ref. the comment on p.24 of the Application Guidelines regarding taking into account the strength of the transmission system). GOs typically do not have automatic access to this data, and their "firewall" separation from TOs may impede such an information exchange unless it is mandated by NERC standards.</li> </ul> <p>Response: The standard is based on planning impedance models used in Protection System coordination that is commonly shared among entities. This information is not related to system status that would reveal that certain Elements that are not in-service; therefore, the drafting team does not see a conflict with the exchange of information or standards of conduct. The criteria requires all generation is in service and all transmission Elements are in their normal operating state when calculating the system impedance.</p> <ul style="list-style-type: none"> <li>- There has been to-date no obligation for entities to maintain records pertaining to the criteria specified in R2, so it may not be possible in all cases to perform the look-back to Jan. 1, 2003 mandated in this requirement. The criteria should therefore be changed to begin, "An Element that is known to have..," instead of, "An Element that has...."</li> </ul> <p>Response: The "January 1, 2003" date has been removed from the standard. Requirement R2 (and new</p>

Organization	Yes or No	Question 3 Comment
		<p>R3) are based on actual Disturbances that occur after the Effective Date of the standard. Change made.</p> <p>- GOs may not know whether their Elements formed the boundary of an island (ref. R2.2 GOs should not be required to take any actions under either R2.1 or R2.2 until and unless the PC/RC/TOP gives notification and provides the relevant necessary information to the GO.</p> <p>Response: The Generator Owner was moved from Requirement R2 to the new Requirement R3 in order to remove the “islanding” criteria for Generator Owners. Change made.</p>
BC Hydro	No	<p>BC Hydro does not agree that the criteria of R2 are reasonable. Only experience of tripping during STABLE power swings should be used.</p> <p>Response: Requirement R1 – Criterion 4, Requirement R2 – Criterion 1, and the new Requirement R3 – Criterion 1, were clarified by adding both “stable and unstable” power swings. Both stable and unstable power swings determine whether an Element will be identified as experiencing a power swing. Change made.</p>
DTE Electric	No	<p>It would seem that the GO and TO could need input from the PC, RC and TP to determine if the conditions are still credible, based on system studies.</p> <p>Response: Requirements R2 (TO) and the new R3 (GO) require the GO and TO to report the Element that tripped in response to a power swing. These requirements allow the Planning Coordinator to be the sole source of funneling the “identified Elements” to the GO and TO. A fifth Criterion was added to Requirement R1 that requires the PC to continue identifying an Element “unless the Planning Coordinator determines the Element is no longer susceptible to power swings.” This ensures visibility of the Elements reported by the GO or TO on an ongoing basis since the Element tripped in response to a power swing. Change made.</p>
Arizona Public Service Co.	No	<p>AZPS believes that the GO and TO are not the appropriate entities to identify the Elements that meet the criteria in R2. The criteria of R2 would be determined based on event analysis and the GO’s and TO’s have</p>

Organization	Yes or No	Question 3 Comment
		<p>limited access to this information.</p> <p>Response: The drafting team contends that the Protection System owner (i.e., Generator Owner and Transmission Owner) is the appropriate entity for reviewing operations. No change made.</p> <p>Also, there are often joint participation projects which then include multiple owners. This would create confusion regarding who is supposed to complete the analysis. AZPS recommends that the RC be required to provide this information since they are necessarily involved in all significant system event analyses.</p> <p>Response: While a BES interrupting device may be contractually owned by multiple entities that are not jointly registered, all of the entities would ultimately be responsible for the requisite documentation and results. Contractually organized entities may share or designate compliance responsibilities as well as associated documentation. No change made.</p>
Bureau of Reclamation	No	<p>The Bureau of Reclamation (Reclamation) believes that the Transmission Planner or Planning Coordinator would be in the best position to determine whether Disturbances continue to be credible. Therefore, Reclamation suggests that the Transmission Planner or Planning Coordinator would be in the best position to identify the Elements in R2. The Transmission Planner or Planning Coordinator should be required to notify the Transmission Owner or Generator Owner of which Elements meet the criteria so that the Transmission Owner or Generator Owner can perform the R3 analysis.</p> <p>Response: The Reliability Coordinator and Transmission Planner have been removed from the standard's Applicability; therefore, Requirement R1 is now only applicable to the Planning Coordinator as a single entity source of identifying Elements. The drafting team asserts that the Planning Coordinator has or has access to the knowledge including the wide-area view. Change made to the Requirement.</p> <p>Reclamation also suggests that the criteria be rephrased to require analysis of data from the previous year only. As written, R2 would require Transmission Owners and Generator Owners to re-analyze data going back to 2003 each year.</p> <p>Response: The "January 1, 2003" date has been removed from the standard. Requirement R2 (and new</p>

Organization	Yes or No	Question 3 Comment
		<p>R3) are based on actual Disturbances that occur after the Effective Date of the standard. Change made. Reclamation believes that the costs of re-analyzing this data would outweigh the benefits. Reclamation believes that NERC should develop a data request to develop a robust initial data set covering January 2003 to present.</p> <p>Response: The drafting team increased the Implementation Plan to three years to provide for the initial influx of identified Elements under Requirement R1. The evaluation of relays under Requirement R4 (previously R3) is to be performed “within 12 full calendar months of receiving notification of an Element ... where the evaluation has not been performed in the last three calendar years.” Change made.</p>
Luminant Generation Company LLC	No	<p>See the response to Question 1. If R2 were modified as proposed in Question 1, then Luminant would agree that these are the appropriate entities.</p> <p>Response: Thank you for your comment. Please see response to Question 1.</p>
Public Service Enterprise Group	No	<p>We disagree with the need for this standard. However, this requirement is so egregious with regard to one item that we offer these comments so that similar language may never appear in any future standards. R2 requires GOs and TOs to evaluate Disturbance records “since January 1, 2003,” a time that will precede the effective date of this standard. A requirement cannot rely upon records that precede the effective date of a standard. As an example, PRC-005-1, which was approved in Order 693, became effective on June 11, 2007, does not require a Registered Entity to have maintenance records available for the period of time that preceded the effective date in order to calculate the next maintenance interval for a relay.</p> <p>Response: The “January 1, 2003” date has been removed from the standard. Requirement R2 (and new R3) are based on actual Disturbances that occur after the Effective Date of the standard. Change made.</p>
American Electric Power	No	<p>Generator Owners may not have the information or expertise needed to determine if their Element formed the boundary of an island (R2 Criteria 2) or if the Disturbance that caused a trip or islanding</p>



Organization	Yes or No	Question 3 Comment
		<p>condition remains to be credible.</p> <p>Response: The term “credible” has been removed from the standard. The drafting team clarified Requirement R1, Criterion 3 by framing the criterion in the present tense to refer to the current assessment(s). Islands caused by natural phenomena (i.e., Disturbances) are covered under Requirement R2.</p> <p>The drafting team modified Requirement R1, Criterion 3 – to include island boundaries due to angular instability within an underfrequency load shedding (UFLS) assessment (i.e., PRC-006), and moved the Generator Owner to the new Requirement R3 in order to remove the “islanding” criteria for Generator Owners. Change made.</p> <p>It is unclear how the operation of Automatic Load Rejection (ALR) on a power generation unit during a system event affects applicability to R2 of the standard. The proper operation of a unit’s ALR controls should not result in its automatic inclusion. Clarity is needed in this standard so that only those relays that operated for the observed or simulated power swings in R1 or R2 are applicable to R3.</p> <p>Response: Automatic Load Rejection controls are not load-responsive and therefore are not applicable to this standard. PRC-026-1 – Attachment A has been added to clarify the protective relay elements that are subject to the standard. Change made.</p>
Tacoma Power	No	<p>Tacoma Power disagrees with the need for this standard.</p> <p>Response: Thank you for your comment.</p>
ISO New England	No	<p>In R2, it is unrealistic to require an entity to provide data on an Element that had tripped since 2003. There is no existing NERC continent-wide disturbance monitoring or misoperation standard that requires data be retained more than 12 months. We recommend that this requirement be removed from the standard or include only Elements that were tripped in the last calendar year.</p> <p>Response: The “January 1, 2003” date has been removed from the standard. Requirement R2 (and new R3) are based on actual Disturbances that occur after the Effective Date of the standard. Change made.</p>

Organization	Yes or No	Question 3 Comment
New York Power Authority	No	<p>The Planning and Reliability Coordinator (ISO in our region) would have records of such disturbances for their control areas. TOs and GOs defer to the ISO to render all final decisions and designations in these types of matters.</p> <p>Response: Thank you for your comment.</p>
MRO NERC Standards Review Forum	Yes	
Tennessee Valley Authority	Yes	
SPP Standards Review Group	Yes	
Dominion	Yes	
Florida Power & Light	Yes	
Duke Energy	Yes	<p>Duke Energy does not agree with the TO and GO combing through 12 years of historical data and determining the events that were a result of a power swing. In addition, the GO and TO would have to maintain documentation of power swing events that have occurred since 2003 for every compliance audit. This would cause an unnecessary administrative burden on the responsible entity and should be viewed as a P81 candidate. A more appropriate set of criteria would be for the TO and GO to identify Elements in R2 that have occurred in the previous calendar year or in the previous audit cycle.</p> <p>Response: The "January 1, 2003" date has been removed from the standard. Requirement R2 (and new</p>

Organization	Yes or No	Question 3 Comment
		R3) are based on actual Disturbances that occur after the Effective Date of the standard. Change made.
Florida Municipal Power Agency	Yes	<p>There is a significant issue with R2 in that it “requires” entities to have records before 1/1/2003. Entities had no knowledge of needing to retain such records (i.e., the cause of a relay trip as a stable power swing). Even if PRC-004 misoperations are the source of such data, there is no requirement to retain records for longer than 12 months (PRC-004 has a 12 month data retention in Section D1.4), and certainly not before June 18, 2007. The requirement should only be on a going forward basis, not going back.</p> <p>Response: The “January 1, 2003” date has been removed from the standard. Requirement R2 (and new R3) are based on actual Disturbances that occur after the Effective Date of the standard. Change made.</p> <p>Note also that “Element” is the wrong term and “Facility” should be used. “Element applies to both BES (including distribution) and non-BES, Facilities is BES. Standards cannot be written to distribution.</p> <p>Response: Section 4.2, Facilities provides sufficient language that the standard is applicable to only “BES Elements.” No change made to the standard based upon the comment.</p>
Puget Sound Energy	Yes	
Bonneville Power Administration	Yes	
Ingleside Cogeneration LP	Yes	
Los Angeles Department of Water and Power	Yes	
Massachusetts	Yes	

Organization	Yes or No	Question 3 Comment
Attorney General		
MidAmerican Energy Company	Yes	
Consolidated Edison, Inc.	Yes	<p>See comment #4 under Question #1. In R2, it is unrealistic to require an entity to provide data on an Element that had tripped since 2003. There is no existing NERC continent-wide disturbance monitoring or misoperation standard that requires data be retained more than 12 months. We recommend that this requirement be removed from the standard or include only Elements that were tripped in the last calendar year.</p> <p>Response: The “January 1, 2003” date has been removed from the standard. Requirement R2 (and new R3) are based on actual Disturbances that occur after the Effective Date of the standard. Change made.</p>
Electric Reliability Council of Texas, Inc.	Yes	
American Transmission Company, LLC	Yes	
Manitoba Hydro	Yes	
Independent Electricity System Operator	Yes	<p>We agree that the Generator Owner and Transmission Owner are the appropriate entities to identify the Elements that meet the criteria in Requirement R2. However, we question the relevance or need to trace back to 2003 for Disturbances that caused an Element to trip due to a power swing or which formed the boundary of an island.</p> <p>Response: The “January 1, 2003” date has been removed from the standard. Requirement R2 (and new</p>

Organization	Yes or No	Question 3 Comment
		<p>R3) are based on actual Disturbances that occur after the Effective Date of the standard. Change made. Further, the term credible Disturbance needs clarification. Please see our comment under Q1, above.</p> <p>Response: Thank you for your comment. Please see the response in Question 1 above.</p>
David Kiguel	Yes	
Ameren	Yes	
Exelon	Yes	
Oncor Electric Delivery LLC	Yes	<p>As currently drafted, R2 requires GOs and TOs to evaluate Disturbance records “since January 1, 2003,” a time that will precede the effective date of this standard. A requirement cannot rely upon records that precede the effective date of a standard. As an example, PRC-005-1, which was approved in Order 693, became effective on June 11, 2007, does not require a Registered Entity to have maintenance records available for the period of time that preceded the effective date in order to calculate the next maintenance interval for a relay. CAN-0008 specifically states “CEAs are not to require registered entities to produce records of testing and maintenance activities conducted prior to June 18, 2007, because keeping such records was not mandatory at that time. Therefore, CEAs are only to require production of actual maintenance and testing records from June 18, 2007 forward.” Oncor would hope the same applies across all Standards and Requirements.</p> <p>Response: The “January 1, 2003” date has been removed from the standard. Requirement R2 (and new R3) are based on actual Disturbances that occur after the Effective Date of the standard. Change made.</p>
Texas Reliability Entity	Yes	<p>The GO and TO are the appropriate responsible entities. The timeframe appears identified in Criteria 1 and 2 back to January 1, 2003 appears onerous. The Northeast Blackout should provide the impetus to look at power swings but may not need to be the basis for the timeframe. Suggestion is to leave date out; auditor discretion would tend to indicate “since last audit”.</p>

Organization	Yes or No	Question 3 Comment
		<p>Response: The "January 1, 2003" date has been removed from the standard. Requirement R2 (and new R3) are based on actual Disturbances that occur after the Effective Date of the standard. Change made.</p> <p>Clarification is requested for Criteria 1 and 2 regarding the term "credible"; who is responsible for determining "credible" (is it tied to TPL-001-4)?</p> <p>Response: The term "credible" has been removed from the standard. The drafting team clarified Requirement R1, Criterion 3 by framing the criterion in the present tense to refer to the current assessment(s). Islands caused by natural phenomena (i.e., Disturbances) are covered under Requirement R2. Change made.</p>
ITC	Yes	<p>We agree the GO and TO are the appropriate entities. However, we suggest removing the inclusion of events prior to the effective date of this standard.</p> <p>Response: The "January 1, 2003" date has been removed from the standard. Requirement R2 (and new R3) are based on actual Disturbances that occur after the Effective Date of the standard. Change made.</p>
Northeast Utilities	Yes	<p>See comment #4 under Question #1. In R2, it is unrealistic to require an entity to provide data on an Element that had tripped since 2003. There is no existing NERC continent-wide disturbance monitoring or misoperation standard that requires data be retained more than 12 months. We recommend that this requirement be removed from the standard or include only Elements that were tripped in the last calendar year.</p> <p>Response: The "January 1, 2003" date has been removed from the standard. Requirement R2 (and new R3) are based on actual Disturbances that occur after the Effective Date of the standard. Change made.</p>
Idaho Power Co.	Yes	<p>Yes if the Requirement is better written to address the comments of question 1. In addition, the GOP and TOP may also need to be included to fully identify disturbances.</p> <p>Response: The Reliability Coordinator and Transmission Planner have been removed from the standard's Applicability; therefore, Requirement R1 is now only applicable to the Planning Coordinator as a single</p>

Organization	Yes or No	Question 3 Comment
		<p>entity source of identifying Elements. The drafting team asserts that the Planning Coordinator has or has access to the knowledge including the wide-area view. Change made to the Requirement.</p> <p>R2 requires entities to rely on records prior to the effective date of the standard - records the entities did not know they were required to keep for this purpose. Either strike R2 or change the wording such that R2 applies to Disturbances that have happened after the effective date of the standard</p> <p>Response: The "January 1, 2003" date has been removed from the standard. Requirement R2 (and new R3) are based on actual Disturbances that occur after the Effective Date of the standard. Change made.</p>
Southern California Edison Company	Yes	
Public Utility District No. 1 of Cowlitz County, WA	Yes	<p>Provided the SDT finds a way to clearly establish the documentation from which the GO and TO will identify the Elements.</p> <p>Response: The drafting team modified Requirement R1, Criterion 3 – to include island boundaries due to angular instability within an underfrequency load shedding (UFLS) assessment (i.e., PRC-006), and moved the Generator Owner to the new Requirement R3 in order to remove the "islanding" criteria for Generator Owners. Change made.</p>
Salt River Project	Yes	
Xcel Energy	Yes	<p>This requirement is a labor intensive, and it is meaningless to perform annually as the system dynamics do not change as fast. It should be recommended to change the frequency to every 4 years.</p> <p>Response: The drafting team increased the Implementation Plan to three years to provide for the initial influx of identified Elements under Requirement R1. The evaluation of relays under Requirement R4 (previously R3) is to be performed "within 12 full calendar months of receiving notification of an Element ... where the evaluation has not been performed in the last three calendar years." Change made.</p> <p>Further, it is unreasonable to set up the criteria to date back to 2003; this should be 4 years from the date</p>

Organization	Yes or No	Question 3 Comment
		<p>of approval at maximum.</p> <p>Response: The “January 1, 2003” date has been removed from the standard. Requirement R2 (and new R3) are based on actual Disturbances that occur after the Effective Date of the standard. Change made.</p> <p>There is no mechanism specified to permit Generation and Transmission Owners to challenge the results of R2. In the event of a dispute, who arbitrates?</p> <p>Response: The Generator Owner (GO) in Requirement R3 and Transmission Owner (GO) in Requirements R2 are required to report the Element that tripped in response to a power swing. These requirements allow the Planning Coordinator to be the sole source of funneling the “identified Elements” to the GO and TO. A fifth Criterion was added to Requirement R1 that requires the Planning Coordinator (PC) to continue identifying an Element “unless the PC determines the Element is no longer susceptible to power swings.” This ensures visibility of the Elements reported by the GO or TO on an ongoing basis since the Element tripped in response to a power swing. The term “credible” has been removed from the standard. Change made.</p>



4. Do you agree with the approach in Requirement R3 to ensure that load-responsive protective relays do not trip in response to stable power swings during non-Fault conditions for an identified Element? If not, please explain.

Summary Consideration: Overwhelmingly 68% of commenter disagreed with the approach in Requirement R3 to ensure that load-responsive protective relays do not trip in response to stable power swings during non-Fault conditions for an identified Element. There were two significant revisions based on comments. The first revision came as a result of 14 comments supported by 88 stakeholders that, in summary, were confused about the performance of Requirement R3 (now R4 in draft 2). To address all of the concerns, the previous Requirement R3 was split into a new Requirement R4 (evaluation) and a new R5 (corrective action). The requirement for reaching agreements with the Planning Coordinator, Reliability Coordinator, and Transmission Planner has been eliminated from Requirements R4 and R5. The new Requirement R4 requires an evaluation of the existing load-responsive protective relays against the criteria now defined in PRC-026-1 – Attachment B. If the existing load-responsive protective relays do not meet the criteria, the new Requirement R5 requires the applicable entity to develop a Corrective Action Plan (CAP) to modify the Protection System to meet the PRC-026-1 – Attachment B Criteria while maintaining dependable fault detection and dependable out-of-step tripping (if out-of-step tripping is applied at the terminal of the Element).

Second, 8 comments by 39 individuals questioned what is a “load-responsive protective relay.” The term and type of relay is widely understood and is any protective functions which could trip with or without time delay on load current. To address the concerns, a clarification has been provided in PRC-026-1 – Attachment A to not only list what is included, but also certain exclusions.

Organization	Yes or No	Question 4 Comment
Northeast Power Coordinating Council	No	The Purpose of the standard is “To ensure that load-responsive protective relays do not trip in response to stable power swings during non-Fault conditions.” The last sentence of Background, Section 5 implies that a protective relay, while blocking for a stable power swing also allows for dependable operation for fault and unstable power swing. Requirement R3 Bullet #4 is contrary to the Purpose of the standard. The sub-Parts of R3 Bullet 4 are “or”, which means that if there isn’t dependable fault detection or dependable out-of-step tripping, agreement would just have to be obtained from the respective Planning Coordinator, Reliability Coordinator, and Transmission Planner of the Element that the existing Protection System design and settings are acceptable. The sub-Parts of R3 Bullet should be an “and”. Item b under the fourth bullet in Requirement R3 is not stated using clear and unambiguous language whereby responsible entities, using reasonable judgment, are able to arrive at a consistent interpretation of the required

Organization	Yes or No	Question 4 Comment
		<p>performance. The R3 Rationale and the Protection System Response to Power Swings technical document provide some clarity; however, the fourth bullet is not clear and troublesome from a compliance perspective. Suggest to consider revising the fourth bullet to ensure the responsible entity understands the balance between security and dependability and how that is to be achieved by either sub-parts “a” or “b”. The standard does not specify any time parameters for developing and correcting the conditions addressed by a CAP. We suggest that time parameters for developing and correcting the conditions addressed by the CAP be addressed within the requirements of the standard.</p> <p>Response: The Purpose statement was modified to note that the purpose is to ensure that relays “are expected to not trip.” The previous Requirement R3 has been split into a new Requirement R4 (evaluation) and a new R5 (corrective action). The new Requirement R4 requires an evaluation of the existing load-responsive protective relays against the criteria now defined in PRC-026-1 – Attachment B. If the existing load-responsive protective relays do not meet the criteria, the new Requirement R5 requires the applicable entity to develop a Corrective Action Plan (CAP) to modify the Protection System to meet the PRC-026-1 – Attachment B Criteria while maintaining dependable fault detection and dependable out-of-step tripping (if out-of-step tripping is applied at the terminal of the Element). Change made.</p> <p>Response: The Corrective Action Plan (CAP) has its own timetable and set of actions that are determined by the entity. The work necessary under the CAP may vary greatly depending on the work being performed; therefore, the drafting team has not specified any timeframes. No change made.</p>
MRO NERC Standards Review Forum	No	<p>The NSRF requests that the SDT provide additional details on how the Lens characteristic is derived and examples of its use with the system parameters that were calculated from the example.</p> <p>Response: Additional clarifications and examples have been added to the Guidelines and Technical Basis. Change made.</p>
Tennessee Valley Authority	No	<p>1) Every year is too often for this requirement. We recommend changing this to every 5 years.</p> <p>Response: The drafting team increased the Implementation Plan to three years to provide for the initial influx of identified Elements under Requirement R1. The evaluation of relays under Requirement R4</p>

Organization	Yes or No	Question 4 Comment
		<p>(previously R3) is to be performed “within 12 full calendar months of receiving notification of an Element ... where the evaluation has not been performed in the last three calendar years.” Change made.</p> <p>2) We believe that the criterion is too specific for a regulatory document. It should allow entities to use their preferred methods for determining if a line is likely to trip during a stable power swing. Recommend changing the first bullet to: “...in response to a stable power swing based on either the criterion below or by another industry accepted method.”</p> <p>Response: The criteria included in the standard are consistent with the NERC System Protection and Control (SPCS), <i>Protection System Response to Power Swings</i>, August 2013<sup>8</sup> (PSRPS Report). The basis for the criteria is documented in the Guidelines and Technical Basis. The drafting team has concluded that a single method for evaluating load-responsive protective relays is the most effective and efficient approach to achieve the reliability objective of the FERC order. No change made.</p> <p>3) At the end of the fourth bullet it states “dependable out-of-step tripping”. We recommend changing this to “dependable unstable power swing tripping”.</p> <p>Response: The drafting team asserts that out-of-step tripping is understood as occurring during unstable power swings. No change made.</p>
SPP Standards Review Group	No	<p>We question the need for the annual assessment required in Requirement R3. PRC-005-2 satisfactorily covers the routine maintenance and testing of protective relays and this requirement would be redundant with those requirements. Additionally, only system changes (topology changes, load/generation changes, etc.) would impact the application of the relays applicable to this requirement. Thus they should only need to be reviewed or re-assessed if those types of changes occurred on the system.</p> <p>Response: The drafting team increased the Implementation Plan to three years to provide for the initial influx of identified Elements under Requirement R1. The evaluation of relays under Requirement R4</p>

<sup>8</sup> NERC System Protection and Control Subcommittee, *Protection System Response to Power Swings*, August 2013: [http://www.nerc.com/comm/PC/System%20Protection%20and%20Control%20Subcommittee%20SPCS%2020/SPCS%20Power%20Swing%20Report\\_Final\\_20131015.pdf](http://www.nerc.com/comm/PC/System%20Protection%20and%20Control%20Subcommittee%20SPCS%2020/SPCS%20Power%20Swing%20Report_Final_20131015.pdf)

Organization	Yes or No	Question 4 Comment
		<p>(previously R3) is to be performed “within 12 full calendar months of receiving notification of an Element ... where the evaluation has not been performed in the last three calendar years.” Change made.</p> <p>We suggest that the 4th bullet under Requirement R3 be made a notification rather than the existing agreement. As stated, the requirement for agreement places unintended risk on the Planning Coordinator, Reliability Coordinator and Transmission Planner. While we agree that if there is no dependable fault detection or out of step tripping the Planning Coordinator, Reliability Coordinator and Transmission Planner would need to be notified, we are unclear how these registered functional entities would have the knowledge of each applicable entity’s protection systems to be able to agree to a correct relay setting. Would the fact that the Planning Coordinator, Reliability Coordinator and Transmission Planner accepted the settings place the responsibility of a cascading event due to the undependable fault detection or out of step tripping on the shoulders of these entities? This risk should be solely placed with the experts that design and maintain protection systems.</p> <p>Both a. and b. under the last bullet of Requirement R3 require the Generator Owner and Transmission Owner to obtain agreement with the Planning Coordinator, Reliability Coordinator and Transmission Planner yet nothing in the standard requires the Planning Coordinator, Reliability Coordinator or Transmission Planner to provide that agreement. Generator Owner and Transmission Owner compliance may hinge on that agreement but there is no incentive for the Planning Coordinator, Reliability Coordinator or Transmission Planner to reach that agreement. We concur with AEP in that rather than requiring agreement, the requirement should only require notification of the Planning Coordinator, Reliability Coordinator and Transmission Planner by the Generator Owner and Transmission Owner.</p> <p>Response: The previous Requirement R3 has been split into a new Requirement R4 (evaluation) and a new R5 (corrective action). The requirement for reaching agreements with the Planning Coordinator, Reliability Coordinator, and Transmission Planner has been eliminated from Requirements R4 and R5. The new Requirement R4 requires an evaluation of the existing load-responsive protective relays against the criteria now defined in PRC-026-1 – Attachment B. If the existing load-responsive protective relays do not meet the criteria, the new Requirement R5 requires the applicable entity to develop a Corrective Action Plan (CAP) to modify the Protection System to meet the PRC-026-1 – Attachment B Criteria while</p>

Organization	Yes or No	Question 4 Comment
		maintaining dependable fault detection and dependable out-of-step tripping (if out-of-step tripping is applied at the terminal of the Element). Change made.
<p>Southern Company;                      Southern Company Services, Inc.;                      Alabama Power Company;                      Georgia Power Company;                      Gulf Power Company;                      Mississippi Power Company;                      Southern Company Generation;                      Southern Company Generation and Energy Marketing</p>	<p>No</p>	<p>The method defined in R3 should be an option for determining susceptibility of a given relay, but the requirement should be for the responsible entity to develop criteria to determine susceptibility of a given relay to tripping for stable power swings and then other requirements to demonstrate the adherence to and compliance with those criteria.</p> <p>Response: The criteria included in the standard are consistent with the NERC System Protection and Control (SPCS), <i>Protection System Response to Power Swings</i>, August 2013<sup>9</sup> (PSRPS Report). The basis for the criteria is documented in the Guidelines and Technical Basis. The drafting team has concluded that a single method for evaluating load-responsive protective relays is the most effective and efficient approach to achieve the reliability objective of the FERC order. No change made.</p> <p>If the prescriptive method of R3 remains in the standard, R3, bullet #4 (b), should explicitly state that it is acceptable for the modifications specified in the CAP not to result in meeting the criteria of R3.</p> <p>Response: The previous Requirement R3 has been split into a new Requirement R4 (evaluation) and a new R5 (corrective action). The requirement for reaching agreements with the Planning Coordinator, Reliability Coordinator, and Transmission Planner has been eliminated from Requirements R4 and R5. The new Requirement R4 requires an evaluation of the existing load-responsive protective relays against the criteria now defined in PRC-026-1 – Attachment B. If the existing load-responsive protective relays do not meet the criteria, the new Requirement R5 requires the applicable entity to develop a Corrective Action Plan (CAP) to modify the Protection System to meet the PRC-026-1 – Attachment B Criteria while maintaining dependable fault detection and dependable out-of-step tripping (if out-of-step tripping is applied at the terminal of the Element).</p> <p>The drafting team contends that meeting the criteria in Requirement R4 (previously R3) while maintaining</p>

<sup>9</sup> NERC System Protection and Control Subcommittee, *Protection System Response to Power Swings*, August 2013: [http://www.nerc.com/comm/PC/System%20Protection%20and%20Control%20Subcommittee%20SPCS%2020/SPCS%20Power%20Swing%20Report\\_Final\\_20131015.pdf](http://www.nerc.com/comm/PC/System%20Protection%20and%20Control%20Subcommittee%20SPCS%2020/SPCS%20Power%20Swing%20Report_Final_20131015.pdf)

Organization	Yes or No	Question 4 Comment
		<p>dependable fault detection and dependable out-of-step tripping (if out-of-step tripping is applied at the terminal of the Element) is achievable. Therefore, the items ‘a’ and ‘b’ under previous Requirement R3, bullet #4 were removed from the standard. The criteria in the PRC-026-1 – Attachment B referenced in Requirement R4 (previously R3) allows some flexibility in the separation angle if supported by a documented stability analysis. Change made.</p>
<p>ISO RTO Council Standards Review Committee</p>	<p>No</p>	<p>R3 and its bulleted items need to be clarified that they apply to the load-responsive relays only, to be consistent with the purpose and scope of the standard, not the Protection System which could include other protective relays or components. However, if the standard is to ensure that Elements do not trip in response to stable power swings during non-Fault conditions, then all references to Protection Systems should be replaced with load-responsive relays.</p> <p>Response: The term “load-responsive protective relays” is widely understood and is any protective functions which could trip with or without time delay, on load current. A clarification has been provided in PRC-026-1 – Attachment A.</p> <p>The drafting team split the previous Requirement R3 into a new Requirement R4 (evaluation) and R5 (corrective action) and included the phrase “load-responsive protective relays” where it uniquely applies to a Protection System. Change made.</p> <p>We are concerned that holding relay engineers to limit load-responsive protection schemes to meet these settings in order to be compliant may not always be in the best interest of bulk power system reliability. Although it is good practice to see that facilities can withstand transients that are expected to dissipate and not pose a recurring threat to the grid, requiring these settings to always be adhered to takes away the ability for the relay engineer to apply engineering judgment if there are conflicting needs to allow for tripping the load-responsive relays in order to protect from another more imposing system threat. These relays are primarily to protect from a specific condition identified by studied and credible faults. This setting may be inside the trip circle identified by the stable power swing. In these cases, the relay engineer makes a best judgment to ensure a balance between which threat is more relevant or immediate to make the appropriate setting. The standard should allow for entities to provide technical evidence that a load-</p>

Organization	Yes or No	Question 4 Comment
		<p>responsive relay may have to be set within a trip circle of a stable power swing, if there is no other protection scheme available to mitigate the primary threat.</p> <p>Response: The previous Requirement R3 has been split into a new Requirement R4 (evaluation) and a new R5 (corrective action). The requirement for reaching agreements with the Planning Coordinator, Reliability Coordinator, and Transmission Planner has been eliminated from Requirements R4 and R5. The new Requirement R4 requires an evaluation of the existing load-responsive protective relays against the criteria now defined in PRC-026-1 – Attachment B. If the existing load-responsive protective relays do not meet the criteria, the new Requirement R5 requires the applicable entity to develop a Corrective Action Plan (CAP) to modify the Protection System to meet the PRC-026-1 – Attachment B Criteria while maintaining dependable fault detection and dependable out-of-step tripping (if out-of-step tripping is applied at the terminal of the Element). Change made.</p>
Dominion	No	<p>Item b under the 4th bullet in Requirement R3 is not stated using clear and unambiguous language whereby responsible entities, using reasonable judgment, are able to arrive at a consistent interpretation of the required performance. The R3 rationale and the Protection System Response to Power Swings technical document provide some clarity; however, the simple fact is the 4th bullet is not clear and troublesome from a compliance perspective. Dominion suggest revising the 4th bullet to ensure the responsible entity understands the balance between security and dependability and how that is to be achieved by either sub-parts a or b.</p> <p>Response: The previous Requirement R3 has been split into a new Requirement R4 (evaluation) and a new R5 (corrective action). The requirement for reaching agreements with the Planning Coordinator, Reliability Coordinator, and Transmission Planner has been eliminated from Requirements R4 and R5. The new Requirement R4 requires an evaluation of the existing load-responsive protective relays against the criteria now defined in PRC-026-1 – Attachment B. If the existing load-responsive protective relays do not meet the criteria, the new Requirement R5 requires the applicable entity to develop a Corrective Action Plan (CAP) to modify the Protection System to meet the PRC-026-1 – Attachment B Criteria while maintaining dependable fault detection and dependable out-of-step tripping (if out-of-step tripping is</p>

Organization	Yes or No	Question 4 Comment
		<p>applied at the terminal of the Element).</p> <p>The drafting team contends that meeting the criteria in Requirement R4 (previously R3) while maintaining dependable fault detection and dependable out-of-step tripping (if out-of-step tripping is applied at the terminal of the Element) is achievable. Therefore, the items ‘a’ and ‘b’ under previous Requirement R3, bullet #4 were removed from the standard. The criteria in the PRC-026-1 – Attachment B referenced in Requirement R4 (previously R3) allows some flexibility in the separation angle if supported by a documented stability analysis. Change made.</p>
FirstEnergy Corp.	No	<p>It would be most helpful to specify protective functions (e.g., 78, 21, 67, 40?) to be included in this analysis, similar to what was done with the Criteria Tables in PRC-025.</p> <p>If the reference to “load-responsive protective relay” in PRC-026-1 R2 means the same as where this terminology is used (and defined) in PRC-025, the scope of work required for the detailed analysis specified in PRC-026-1 R3 is quite significant.</p> <p>Response: The term “load-responsive protective relays” is widely understood and is any protective functions which could trip with or without time delay, on load current. A clarification has been provided in PRC-026-1 – Attachment A. Change made.</p> <p>Technical resources to perform this analysis on each applicable relay could be difficult for many GOs to commit or obtain, and it would be difficult to accomplish the analyses in a short timeframe. One year is unrealistic, especially considering the concern stems from an incident that occurred nearly eleven years ago.</p> <p>Response: The “January 1, 2003” date has been removed from the standard. Requirement R2 (and new R3) are based on actual Disturbances that occur after the Effective Date of the standard.</p> <p>The drafting team revised Requirement R4 (previously R3) from “each calendar year” to “within 12 full calendar months of receiving notification of an Element pursuant to Requirement R1 or within 12 full calendar months of identifying an Element pursuant to Requirement R2 or R3,” “where the evaluation has</p>



Organization	Yes or No	Question 4 Comment
		<p>not been performed in the last three calendar years.” Change made.</p> <p>Further, an annual demonstration with associated evidence is potentially financially burdensome, and seemingly unnecessary if there are no changes to a Unit’s protection system. Changes to applied protection are already captured via the coordination requirement in PRC-001, and are available to the PC, RC and TP.</p> <p>Response: The drafting team modified the Implementation Plan (to 36 months) and several Requirements to provide additional time to reduce the burden. Also, the standard is consistent with the PSRPS Report which recommends a focused approach to identifying Elements that are most susceptible to power swings and therefore reduces the financial burden by not requiring all relays to be in scope. Changes made.</p> <p>Again, in a regulated vs. competitive environment, it may be difficult to obtain system data needed for such calculations. However, if the only piece of information needed from the TO is a Thévenin impedance (system equivalent) at the Point of Interconnection, acquiring this should not be a problem.</p> <p>Response: The Application Guidelines have been clarified that the only requirement for the GO is to have the Thévenin impedance (system equivalent). Change made.</p>
PPL NERC Registered Affiliates	No	<p>We agree with R3 in principle, but there are presently some barriers to the specified stand-alone nature of GO and TO obligations:</p> <ul style="list-style-type: none"> <li>- The statement, “Demonstrate that the existing Protection System is not expected to trip in response to a stable power swing based on the criterion below,” in R3 should be replaced by, “Demonstrate that the existing Protection System is programmed per the criterion below.” The reason for this change is that, while the criterion on p.6 of PRC-026-1 is the appropriate “textbook” way of setting-up an out-of-step relay, the genuinely authoritative means of showing that tripping will not occur for stable power swings is by use of a transient stability program as discussed in the first paragraph on p.24 of the Application Guidelines. Such programs are far from simple to set-up and operate however, GOs do not typically have or run them, and the system data required is known only to the TO and TOP. The requirements and Application Guidelines should make it clear that GOs have no involvement with transient stability</li> </ul>

Organization	Yes or No	Question 4 Comment
		<p>programs.</p> <p>Response: The drafting team modified the criteria now contained in PRC-026-1 – Attachment B from “an angle less than 120 degrees as agreed upon” to “an angle less than 120 degrees where a documented stability analysis demonstrates the expected maximum stable separation angle is less than 120 degrees.” Change made.</p> <p>The Guidelines and Technical Basis have been supplemented to address the concern of how to perform the evaluation of the relays. Examples demonstrate a means other than the use of stability analysis programs. The same techniques or concepts used in transmission applications are also used for generator applications. Change made.</p> <p>- The statement, “For cases where infeed affects the apparent impedance (multiple unit connected generators connected to a transmission switchyard), the Generator Owner will provide the unit and relay data to the Transmission Planner for analysis,” indicates that compliance responsibility can as a matter of practicality shift to another entity under certain circumstances, but the requirements do not ensure that such transactions happen. The, “obtain agreement,” alternatives under the 4th bull-dot of R3 do not obligate the PC/RC/TOP to perform studies or take other actions to help facilitate compliance under R3. PRC-026-1 needs revision to explicitly define the circumstances and mechanisms for multiple-entity collaboration in performing analyses.</p> <p>Response: The previous Requirement R3 has been split into a new Requirement R4 (evaluation) and a new R5 (corrective action). The requirement for reaching agreements with the Planning Coordinator, Reliability Coordinator, and Transmission Planner has been eliminated from Requirements R4 and R5. The new Requirement R4 requires an evaluation of the existing load-responsive protective relays against the criteria now defined in PRC-026-1 – Attachment B. If the existing load-responsive protective relays do not meet the criteria, the new Requirement R5 requires the applicable entity to develop a Corrective Action Plan (CAP) to modify the Protection System to meet the PRC-026-1 – Attachment B Criteria while maintaining dependable fault detection and dependable out-of-step tripping (if out-of-step tripping is applied at the terminal of the Element). Change made.</p>

Organization	Yes or No	Question 4 Comment
Florida Municipal Power Agency	No	<p>See response to Question 1, the TO/GO should only respond to those issued identified by the PC/TP and not all Facilities that meet the criteria of R1.</p> <p>Response: The drafting team asserts that it has implemented an approach consistent with the recommendations of the NERC System Protection and Control Subcommittee (SPCS) technical report, <i>Protection System Response to Power Swings, August 2013</i><sup>10</sup> (PSRPS Report). The standard does not preclude the Planning Coordinator providing information to the Generator Owner or Transmission Owner about the Element and any known stability issues, power swings, or apparent impedance characteristics; however, the Elements need to be reported as a part of ensuring the Generator Owner and Transmission Owner are aware of Elements that are susceptible. Change made.</p>
DTE Electric	No	<p>Based on the criterion for R3, it appears that only impedance relays are in scope. What about other relay types? Specific criteria for all relay types should be provided along with examples on how to demonstrate a no trip response.</p> <p>Response: The term “load-responsive protective relays” is widely understood and is any protective functions which could trip with or without time delay, on load current. A clarification has been provided in PRC-026-1 – Attachment A. Change made.</p>
Arizona Public Service Co.	No	<p>AZPS would recommend changing Protection System to load-responsive protective relays and define what type of relays qualifies as load-responsive protective relays. If the drafting team does not agree with defining load-responsive relays, they should specifically state the relay type (i.e. zone protection) rather than using the broader term Protection System.</p> <p>Response: The term “load-responsive protective relays” is widely understood and is any protective functions which could trip with or without time delay, on load current. A clarification has been provided in</p>

<sup>10</sup> NERC System Protection and Control Subcommittee, *Protection System Response to Power Swings*, August 2013: [http://www.nerc.com/comm/PC/System%20Protection%20and%20Control%20Subcommittee%20SPCS%2020/SPCS%20Power%20Swing%20Report\\_Final\\_20131015.pdf](http://www.nerc.com/comm/PC/System%20Protection%20and%20Control%20Subcommittee%20SPCS%2020/SPCS%20Power%20Swing%20Report_Final_20131015.pdf)

Organization	Yes or No	Question 4 Comment
		PRC-026-1 – Attachment A. Change made.
Luminant Generation Company LLC	No	<p>Requirement R3 focuses on a method commonly used for transmission application. Generator Owners will not be able to use this method for elements that satisfy the criteria in Requirement R1 and R2 for impedance relays used at the generator terminals or at the high voltage side of the Generator Step-up Transformer. Transmission Planners have the tools and data to perform these studies. A requirement should be added for Transmission Planners to provide the data to the Generation Owners for elements that have stable power swings that challenge the relay. Luminant recommends the following additional requirement. “Each Planning Coordinator, Reliability Coordinator, and Transmission Planner shall, within the first quarter month of each calendar year provide to the identified Generator Owner or Transmission Owner pursuant to R1, the stable power swing characteristics (i.e. R-X vs time, current vs time plots, voltage and current vs time) and identified event information.” In addition, the criterion in Requirement R3 considers distance relays which is a subset of load responsive relays used in Generating Facilities. Protective relays such as loss of field, time overcurrent, and voltage controlled overcurrent relays should be excluded and listed in an Attachment similar to PRC-023.</p> <p>Response: The standard does not preclude the Planning Coordinator from providing information to the Generator Owner (GO) or Transmission Owner (TO) about the Element and any known stability issues, power swings, or apparent impedance characteristics; however, the Elements need to be reported as a part of ensuring the GO and TO are aware of Elements that are susceptible.</p> <p>The Guidelines and Technical Basis have been supplemented to address the concern of how to perform the evaluation of the relays. Examples demonstrate a means other than the use of stability analysis programs. The same techniques or concepts used in transmission applications are also used for generator applications.</p> <p>The term “load-responsive protective relays” is widely understood and is any protective functions which could trip with or without time delay, on load current. A clarification has been provided in PRC-026-1 – Attachment A. Change made.</p>

Organization	Yes or No	Question 4 Comment
Ingleside Cogeneration LP	No	<p>ICLP agrees that the Transmission Owner and Generator Owner is in the best position to provide the equipment models and relay settings necessary to perform an adequate assessment. However, the application guidelines contain several statements that infer that the Transmission Planner must be involved in the process (e.g.; the TP must be consulted to validate the slip rates of power swing blocking schemes or if infeed affects the apparent impedance). In our view, there must be a mandatory means to engage the TP when such coordination is required. Otherwise, a TP could refuse to support the analysis for any reason, leaving the TO or GO to look for other less sufficient alternatives. Even if the Transmission Planner’s reasons are justified, the Element owner may be found in violation of R3 due to circumstances out of their control. ICLP suggests that the same situation was addressed in the generator validation standards - which also requires GO/TP coordination to evaluate local system performance - and could be applied in PRC-026-1.</p> <p>Response: The previous Requirement R3 has been split into a new Requirement R4 (evaluation) and a new R5 (corrective action). The requirement for reaching agreements with the Planning Coordinator, Reliability Coordinator, and Transmission Planner has been eliminated from Requirements R4 and R5. The new Requirement R4 requires an evaluation of the existing load-responsive protective relays against the criteria now defined in PRC-026-1 – Attachment B. If the existing load-responsive protective relays do not meet the criteria, the new Requirement R5 requires the applicable entity to develop a Corrective Action Plan (CAP) to modify the Protection System to meet the PRC-026-1 – Attachment B Criteria while maintaining dependable fault detection and dependable out-of-step tripping (if out-of-step tripping is applied at the terminal of the Element). The drafting team removed the Application Guidelines text regarding “slip rates” to avoid confusion. Change made.</p>
Public Service Enterprise Group	No	<p>We disagree with the need for this standard.</p> <p>Response: Thank you for your comment. Please see response in Question 1 above.</p>
MidAmerican Energy Company	No	<p>While the reliability concept of preventing unnecessary overtripping is understood, the NERC white paper supporting the PRC-026 standard indicated that tripping due to stable power swings neither contributed</p>

Organization	Yes or No	Question 4 Comment
		<p>to blackouts or increased the severity of blackouts since 1965.</p> <p>The NERC standards drafting team should consider limiting the scope in R1 and R3 to out-of-step transmission related protection systems specifically designed and installed to monitor weak ties between areas or islands. These systems would open tie-lines in predetermined locations between areas in an attempt to balance load and generation between groups of generators that swing together during the identified power swings.</p> <p>Response: The proposed standard is consistent with the PSRPS Report which recommends a focused approach to identifying Elements that are most susceptible to power swings. No change made.</p>
American Electric Power	No	<p>In reference to R3, bullet point four, sub items a and b, we do not believe it is necessary to obtain further agreement with the PC, RC and TP, as there is no benefit to reliability (since it was not possible to achieve dependability) and represents an unnecessary administrative burden. Rather, the TO should be required only to *notify* the PC, RC, and TP. The bullet points of R3 should be revised to replace “Demonstrate that the existing protection system is not expected to trip...” with “Demonstrate that the existing Protection System satisfies the criteria...”. This would prevent the GO or TO from being found non-compliant if they were to set the relaying in accordance with the criterion, but unforeseen events caused a relay to operate.</p> <p>Response: The previous Requirement R3 has been split into a new Requirement R4 (evaluation) and a new R5 (corrective action). The requirement for reaching agreements with the Planning Coordinator, Reliability Coordinator, and Transmission Planner has been eliminated from Requirements R4 and R5. The new Requirement R4 requires an evaluation of the existing load-responsive protective relays against the criteria now defined in PRC-026-1 – Attachment B. If the existing load-responsive protective relays do not meet the criteria, the new Requirement R5 requires the applicable entity to develop a Corrective Action Plan (CAP) to modify the Protection System to meet the PRC-026-1 – Attachment B Criteria while maintaining dependable fault detection and dependable out-of-step tripping (if out-of-step tripping is applied at the terminal of the Element). Change made.</p> <p>We agree with the approach, but do not believe that R3 would need to be executed annually. It should</p>

Organization	Yes or No	Question 4 Comment
		<p>only need to be done once per relay until something about the relay in question or the transmission system in the immediate vicinity changes.</p> <p>Response: The drafting team increased the Implementation Plan to three years to provide for the initial influx of identified Elements under Requirement R1. The evaluation of relays under Requirement R4 (previously R3) is to be performed “within 12 full calendar months of receiving notification of an Element ... where the evaluation has not been performed in the last three calendar years.” Change made.</p>
<p>Consolidated Edison, Inc.</p>	<p>No</p>	<p>The purpose of the standard is “to ensure that load responsive relay do not trip in response to stable power swing during non-fault condition.” The last sentence of Background, Section 5 implies that protective relay while blocking for a stable power swing also allows for dependable operation for fault and unstable power swing. Bullet #4 in R3 indicates that the GO and TO must obtain agreement if dependable protection or dependable out-of-step tripping is not provided by a protection system that is immune to a stable power swing. Bullet #4 seems to imply that the purpose of the standard is to ensure blocking for a stable power swing and dependable tripping for unstable power swing. The drafting team needs to be very clear in the standard what the intention is. For instance, a line current differential scheme is immune to stable and unstable power swing and will provide dependable tripping for fault. The criteria as written implies that this type of scheme will need to be modified or an agreement will need to be obtained from the PC, RC and TP to deploy since it does not provide dependable out-of-step tripping.</p> <p>Response: The Purpose statement was modified to note that the purpose is to ensure that relays “are expected to not trip.” The previous Requirement R3 has been split into a new Requirement R4 (evaluation) and a new R5 (corrective action). The new Requirement R4 requires an evaluation of the existing load-responsive protective relays against the criteria now defined in PRC-026-1 – Attachment B. If the existing load-responsive protective relays do not meet the criteria, the new Requirement R5 requires the applicable entity to develop a Corrective Action Plan (CAP) to modify the Protection System to meet the PRC-026-1 – Attachment B Criteria while maintaining dependable fault detection and dependable out-of-step tripping (if out-of-step tripping is applied at the terminal of the Element). Change made.</p> <p>An exclusion for current differential relay, pilot wire relay, and phase comparison relay was added to</p>

Organization	Yes or No	Question 4 Comment
		Attachment A.
American Transmission Company, LLC	No	<p>ATC requests that the SDT provide additional details on how the Lens characteristic is derived and examples of its use with the system parameters that were calculated from the example.</p> <p>Response: The Guidelines and Technical Basis have been supplemented to address the concern of how to perform the evaluation of the relays. Change made.</p>
Independent Electricity System Operator	No	<p>R3 and its bulleted items need to be clarified that they apply to the load-responsive relays only, to be consistent with the purpose and scope of the standard, not the Protection System which could include other protective relays or components. However, if the standard is to ensure that Elements do not trip in response to stable power swings during non-Fault conditions, then all references to Protection Systems should be replaced with load-responsive relays.</p> <p>Response: The drafting team split the previous Requirement R3 into a new Requirement R4 (evaluation) and R5 (corrective action) and included the phrase “load-responsive protective relays” where it uniquely applies to a Protection System. Change made.</p> <p>Bullet number four requires to prove dependable out-of-step tripping. However the entity may decide to use selective tripping when out- of-step conditions are detected. Studies show that in case of severe disturbance selective tripping when out-of step conditions are detected can increase the chance of creating successfully islands. We suggest changing the wording from “dependable out-of-step tripping” to “dependable out-of-step detection”.</p> <p>Response: Requirement R4 (previously R3) and the new Requirement R5 were modified to provide clarity that dependable out-of-step tripping only applies if out-of-step tripping is applied at the terminal of an Element. Change made.</p>
Tacoma Power	No	<p>Tacoma Power disagrees with the need for this standard. However, assuming FERC does not provide relief from its directive to develop this standard, the transient, rather than sub-transient, impedance may represent a better model. Granted, as noted in the Application Guidelines, the sub-transient impedance</p>



Organization	Yes or No	Question 4 Comment
		<p>would yield a more conservative assessment.</p> <p>Response: The drafting team made a modification to allow entities the option of using transient or sub-transient reactance. Change made.</p>
Ameren	No	<p>Even though we may be able to accept and appreciate the SDT’s approach; our recommended changes to this approach are as follows:</p> <p>(1) Change 1st sentence of Criterion to “Only load sensitive, high speed distance relays are within scope (e.g. zone 1 phase distance, pilot zone phase distance). For such a distance relay impedance characteristic, used for tripping, that is completely....” which adds the first sentence for clarity. We believe that this comment is consistent with the SDT’s answers in NERC’s 5/12/2014 webinar.</p> <p>Response: A clarification has been provided in PRC-026-1 – Attachment A. For example, relay elements that are intended to trip after time delays of 15 cycles or greater are excluded. Change made.</p> <p>(2) Change Criterion #3 to transient reactance, because it aligns better with power swing time constants (see Reimert text pages 40, 289, 291, and particularly bottom of page 302).</p> <p>Response: The drafting team made a modification to allow entities the option of using transient or sub-transient reactance. Change made.</p> <p>(3) Change ‘once each calendar year’ to ‘within 2 calendar years of initial identification, and once every 5 calendar years thereafter’ because once each calendar year is too frequent.</p> <p>Response: The drafting team increased the Implementation Plan to three years to provide for the initial influx of identified Elements under Requirement R1. The evaluation of relays under Requirement R4 (previously R3) is to be performed “within 12 full calendar months of receiving notification of an Element ... where the evaluation has not been performed in the last three calendar years.” Change made.</p>
ISO New England	No	<p>The option under the fourth bullet requires that the Generator Owner and Transmission Owner obtain agreement from the respective Planning Coordinator, Reliability Coordinator and Transmission Planner of the Element that either: (a) the existing Protection System design and settings are acceptable, or (b) a</p>

Organization	Yes or No	Question 4 Comment
		<p>modification of the Protection System design, settings or both are acceptable and develop a corrective action plan for this modification of the corrective action plan. This requires specialized knowledge and coordination that is not typical for Planning and Reliability Coordinators.</p> <p>Response: The previous Requirement R3 has been split into a new Requirement R4 (evaluation) and a new R5 (corrective action). The requirement for reaching agreements with the Planning Coordinator, Reliability Coordinator, and Transmission Planner has been eliminated from Requirements R4 and R5. The new Requirement R4 requires an evaluation of the existing load-responsive protective relays against the criteria now defined in PRC-026-1 – Attachment B. If the existing load-responsive protective relays do not meet the criteria, the new Requirement R5 requires the applicable entity to develop a Corrective Action Plan (CAP) to modify the Protection System to meet the PRC-026-1 – Attachment B Criteria while maintaining dependable fault detection and dependable out-of-step tripping (if out-of-step tripping is applied at the terminal of the Element). Change made.</p>
New York Power Authority	No	<p>The more relevant approach, as is recommended by the PSRPS technical document, is that you do take corrective actions for unstable power swings. This was determined to be a far greater concern than not taking actions for stable swings.</p> <p>Response: The previous Requirement R3 has been split into a new Requirement R4 and a new R5. The new Requirement R4 requires an evaluation of the existing relays against the criteria now defined in PRC-026-1 – Attachment B. If the existing relays do not meet the criteria, the new Requirement R5 requires an entity to develop a Corrective Action Plan (CAP) to modify the Protection System to meet the PRC-026-1 – Attachment B Criteria A and B while maintaining dependable fault detection and dependable out-of-step tripping (if out-of-step tripping is applied at the terminal of the Element). These changes remove the ambiguity around the previous Requirement R3 language. Change made.</p> <p>A more accurate description of “load responsive” protective relays is also necessary.</p> <p>Response: The term “load-responsive protective relays” is widely understood and is any protective functions which could trip with or without time delay, on load current. A clarification has been provided in</p>

Organization	Yes or No	Question 4 Comment
		<p>PRC-026-1 – Attachment A. Change made.</p> <p>This Standard seems to just repeat what is in the PSRPS technical document, without the necessary elaborations needed for proper understanding.</p> <p>Response: The Guidelines and Technical Basis have been supplemented to address the concern of how to perform the evaluation of the relays. Change made.</p>
Oncor Electric Delivery LLC	No	<p>See response to question #1.</p> <p>Response: See response in Question 1.</p>
ITC	No	<p>In general we agree with this approach. However, we disagree with requiring compliance of one entity to be contingent on another entities agreement. We recommend changing to require notification instead of “agreement” in the fourth bullet and Criterion 1, second bullet.</p> <p>Response: The Purpose statement was modified to note that the purpose is to ensure that relays “are expected to not trip.” The previous Requirement R3 has been split into a new Requirement R4 (evaluation) and a new R5 (corrective action). The new Requirement R4 requires an evaluation of the existing load-responsive protective relays against the criteria now defined in PRC-026-1 – Attachment B. If the existing load-responsive protective relays do not meet the criteria, the new Requirement R5 requires the applicable entity to develop a Corrective Action Plan (CAP) to modify the Protection System to meet the PRC-026-1 – Attachment B Criteria while maintaining dependable fault detection and dependable out-of-step tripping (if out-of-step tripping is applied at the terminal of the Element).</p> <p>The agreement has been removed from Bullet #2 of the criterion (now PRC-026-1 – Attachment B). The criterion now allows an angle less than 120 degrees to be used where a documented stability analysis demonstrates the expected maximum stable separation angle is less than 120 degrees. Change made.</p>
Northeast Utilities	No	<p>The purpose of the standard is “to ensure that load responsive relay do not trip in response to stable power swing during non-fault condition.” The last sentence of Background, Section 5 implies that</p>

Organization	Yes or No	Question 4 Comment
		<p>protective relay while blocking for a stable power swing also allows for dependable operation for fault and unstable power swing. Bullet #4 in R3 indicates that the GO and TO must obtain agreement if dependable protection or dependable out-of-step tripping is not provided by a protection system that is immune to a stable power swing. Bullet #4 seems to imply that the purpose of the standard is to ensure blocking for a stable power swing and dependable tripping for unstable power swing. The drafting team needs to be very clear in the standard what the intention is. For instance, a line current differential scheme is immune to stable and unstable power swing and will provide dependable tripping for fault. The criteria as written implies that this type of scheme will need to be modified or an agreement will need to be obtained from the PC, RC and TP to deploy since it does not provide dependable out-of-step tripping.</p> <p>Response: The Purpose statement was modified to note that the purpose is to ensure that relays “are expected to not trip.” The previous Requirement R3 has been split into a new Requirement R4 and a new R5. The new Requirement R4 requires an evaluation of the existing relays against the criteria now defined in PRC-026-1 – Attachment B. If the existing relays do not meet the criteria, the new Requirement R5 requires an entity to develop a Corrective Action Plan (CAP) to modify the Protection System to meet the PRC-026-1 – Attachment B Criteria A and B while maintaining dependable fault detection and dependable out-of-step tripping (if out-of-step tripping is applied at the terminal of the Element). An exclusion for current differential relay, pilot wire relay, and phase comparison relay was added to PRC-026-1 – Attachment A. Change made.</p>
Idaho Power Co.	No	<p>No. The Requirement as written is onerous to perform annually. Performing these checks during an initial implementation period for the standard is appropriate to ensure the relays will perform as designed (for tripping or blocking). After an initial assessment period, a re-check at longer intervals or triggered by system changes would also be appropriate.</p> <p>Response: The drafting team increased the Implementation Plan to three years to provide for the initial influx of identified Elements under Requirement R1. The evaluation of relays under Requirement R4 (previously R3) is to be performed “within 12 full calendar months of receiving notification of an Element ... where the evaluation has not been performed in the last three calendar years.” Change made.</p>

Organization	Yes or No	Question 4 Comment
		<p>Further, as currently written, the R3 language requires one of the 4 bulleted items to be done, but the language on the 4th bullet implies that the first three be attempted first. If the first three are to be done prior to the 4th, should that bullet not be its own Requirement, such as an R3.1?</p> <p>Response: The previous Requirement R3 has been split into a new Requirement R4 and a new R5. The new Requirement R4 requires an evaluation of the existing relays against the criteria now defined in PRC-026-1 – Attachment B. If the existing relays do not meet the criteria, the new Requirement R5 requires an entity to develop a Corrective Action Plan (CAP) to modify the Protection System to meet the PRC-026-1 – Attachment B Criteria A and B while maintaining dependable fault detection and dependable out-of-step tripping (if out-of-step tripping is applied at the terminal of the Element). These changes remove the ambiguity around the previous Requirement R3 language. Change made.</p> <p>The general approach is reasonable but an annual review is excessive. Bi-annually at the most and then by exception for any relay or system changes.</p> <p>Response: See response to first comment.</p>
Southern California Edison Company	No	<p>Although we appreciate the drafting team's efforts, we believe that Requirement R3 is unnecessarily burdensome from a compliance perspective. We would suggest that the analyses of Elements be performed on an initial basis, and then when changes occur. An annual analyses of all the Elements assets is not efficient or warranted.</p> <p>Response: The drafting team increased the Implementation Plan to three years to provide for the initial influx of identified Elements under Requirement R1. The evaluation of relays under Requirement R4 (previously R3) is to be performed “within 12 full calendar months of receiving notification of an Element ... where the evaluation has not been performed in the last three calendar years.” Change made.</p>
PacifiCorp	Yes	
ACES Standards	Yes	(1) We agree generally with the approach but note that there are specific issues.

Organization	Yes or No	Question 4 Comment
Collaborators		<p>(2) First, we disagree with the sub-bullet requiring the GO or TO to obtain agreement from the PC, TP, and RC to retain existing Protection System settings to maintain dependable fault detection. Dependable fault detection is a safety issue. A TO or GO should not have to get agreement to maintain Protection System settings that are safe. The TO and GO should notify the PC, TP, RC and TOP of such issues and then the PC and TP can plan the system accordingly (i.e. meet the TPL standards) and the TOP can operate the system accordingly (i.e. meet the IROL standards).</p> <p>Response: The previous Requirement R3 has been split into a new Requirement R4 (evaluation) and a new R5 (corrective action). The requirement for reaching agreements with the Planning Coordinator, Reliability Coordinator, and Transmission Planner has been eliminated from Requirements R4 and R5. The new Requirement R4 requires an evaluation of the existing load-responsive protective relays against the criteria now defined in PRC-026-1 – Attachment B. If the existing load-responsive protective relays do not meet the criteria, the new Requirement R5 requires the applicable entity to develop a Corrective Action Plan (CAP) to modify the Protection System to meet the PRC-026-1 – Attachment B Criteria while maintaining dependable fault detection and dependable out-of-step tripping (if out-of-step tripping is applied at the terminal of the Element). Change made.</p> <p>(3) Obtaining the agreement of the PC, RC, and TP is problematic and repeats similar problems that are associated with PRC-023 R3. PRC-023-2 R3 requires the GO, TO, and DP to obtain the agreement of the PC, RC and TOP to set the relay loadability using certain criteria. The problem is there is no obligation for the PC, RC or TOP to agree and they often are reluctant to agree due to legal liability. In other words, no one really knows what they are agreeing to or the implications except that the standard requires it. These same problems will be experienced here with this requirement. The need for the PC, TP and RC to agree should be removed or more specification should be provided for what this means.</p> <p>Response: The previous Requirement R3 has been split into a new Requirement R4 (evaluation) and a new R5 (corrective action). The requirement for reaching agreements with the Planning Coordinator, Reliability Coordinator, and Transmission Planner has been eliminated from Requirements R4 and R5. The new Requirement R4 requires an evaluation of the existing load-responsive protective relays against the criteria now defined in PRC-026-1 – Attachment B. If the existing load-responsive protective relays do not</p>

Organization	Yes or No	Question 4 Comment
		<p>meet the criteria, the new Requirement R5 requires the applicable entity to develop a Corrective Action Plan (CAP) to modify the Protection System to meet the PRC-026-1 – Attachment B Criteria while maintaining dependable fault detection and dependable out-of-step tripping (if out-of-step tripping is applied at the terminal of the Element). Change made.</p> <p>(4) For the criterion, we disagree with the need to require the PC, RC, and TP to agree to use a system separation angle of less than 120 degrees. All that should be required is for the TO or GO to provide sound engineering justification for using an angle less than 120 degrees.</p> <p>Response: The drafting team modified the criteria now contained in PRC-026-1 – Attachment B from “an angle less than 120 degrees as agreed upon” to “an angle less than 120 degrees where a documented stability analysis demonstrates the expected maximum stable separation angle is less than 120 degrees.” Change made.</p>
Duke Energy	Yes	
BC Hydro	Yes	
Puget Sound Energy	Yes	<p>While this approach seems reasonable, there is currently a lack of ability to model the load-responsive protective relays to determine whether a protection system is expected to trip in response to a stable power swing. While this capability is currently being implemented, it will not be completed by the proposed implementation date of this standard.</p> <p>Response: The drafting team asserts that the standard does not require the inclusion of relay models. Requirement R1, Criterion 4 is not requiring a study, but the identification of any Element that was observed as tripping in the most recent Planning Assessment pursuant to TPL-001-4, R4, Part 4.3.1.3 – “Tripping of Transmission lines and transformers where transient swings cause Protection System operation based on generic or actual relay models” which becomes effective January 1, 2015 (U.S.). Other clarifying changes were made to Requirement R1, Criterion 4.</p>

Organization	Yes or No	Question 4 Comment
Bonneville Power Administration	Yes	<p>BPA believes R3 should be modified for greater clarity and to allow for intentional power swing relays designed to be tripped in a controlled manner to protect the BES. Additionally, the wording in the fourth bullet appears to be inconsistent with the Rationale for R3.</p> <p>Response: The previous Requirement R3 has been split into a new Requirement R4 (evaluation) and a new R5 (corrective action). The requirement for reaching agreements with the Planning Coordinator, Reliability Coordinator, and Transmission Planner has been eliminated from Requirements R4 and R5. The new Requirement R4 requires an evaluation of the existing load-responsive protective relays against the criteria now defined in PRC-026-1 – Attachment B. If the existing load-responsive protective relays do not meet the criteria, the new Requirement R5 requires the applicable entity to develop a Corrective Action Plan (CAP) to modify the Protection System to meet the PRC-026-1 – Attachment B Criteria while maintaining dependable fault detection and dependable out-of-step tripping (if out-of-step tripping is applied at the terminal of the Element). Change made.</p>
Bureau of Reclamation	Yes	
Massachusetts Attorney General	Yes	
Manitoba Hydro	Yes	
David Kiguel	Yes	
Exelon	Yes	
Texas Reliability Entity	Yes	<p>Suggest substituting “R1 and R2” for “R1 or R2” to avoid the possibility of confusion. As written, it could be construed that GOs and TOs can choose to address either R1 or R2 and not address both R1 and R2.</p> <p>Response: The drafting team contends that the “or” in Requirement R3 (now R4) is correct. The Generator</p>



Organization	Yes or No	Question 4 Comment
		Owner and Transmission Owner must evaluate its relays for each Element identified by the Planning Coordinator in Requirement R1, the Transmission Owner in Requirement R2, or Generator Owner in Requirement R3.
Salt River Project	Yes	
Xcel Energy	Yes	<p>This requirement is a labor intensive, and it is meaningless to perform annually as the system dynamics do not change as fast. It should be recommended to change the frequency to every 4 years.</p> <p>Response: The drafting team increased the Implementation Plan to three years to provide for the initial influx of identified Elements under Requirement R1. The evaluation of relays under Requirement R4 (previously R3) is to be performed “within 12 full calendar months of receiving notification of an Element ... where the evaluation has not been performed in the last three calendar years.” Change made.</p> <p>When seeking agreement from the Planning or Reliability Coordinator that existing settings or specific modifications are adequate, a specified response time is required to permit alternate actions to be undertaken, should agreement not be obtained.</p> <p>Response: The previous Requirement R3 has been split into a new Requirement R4 (evaluation) and a new R5 (corrective action). The requirement for reaching agreements with the Planning Coordinator, Reliability Coordinator, and Transmission Planner has been eliminated from Requirements R4 and R5. The new Requirement R4 requires an evaluation of the existing load-responsive protective relays against the criteria now defined in PRC-026-1 – Attachment B. If the existing load-responsive protective relays do not meet the criteria, the new Requirement R5 requires the applicable entity to develop a Corrective Action Plan (CAP) to modify the Protection System to meet the PRC-026-1 – Attachment B Criteria while maintaining dependable fault detection and dependable out-of-step tripping (if out-of-step tripping is applied at the terminal of the Element). Change made.</p>

5. Do you agree with the proposed Violation Risk Factors (VRF) and Violation Severity Levels (VSL) for the proposed requirements? If not, please provide a basis for revising a VRF and/or what would improve the clarity of the VSLs

Summary Consideration: Sixty percent of commenters favor the proposed Violation Risk Factors (VRF) and Violation Severity Levels (VSL) for the proposed requirements. There were no specific common comments and due to the significant changes to the Requirements in Draft 2, a summary is not being provided.

Organization	Yes or No	Question 5 Comment
SPP Standards Review Group	No	<p>The VSLs for Requirement R1 should be changed in consideration to the point we made in our response to Question 2.</p> <p>Insert an 'an' between 'identified' and 'Element' in the VSLs for Requirement R2.</p> <p><i>Response: Correction made.</i></p> <p>References to 30-, 60-, and 90-calendar days should be hyphenated in the VSLs for Requirements R1, R2 and R3.</p> <p><i>Response: The use of a hyphen as suggested is not consistent with the NERC style guide.</i></p>
ACES Standards Collaborators	No	<p>(1) We agree that the VRFs for Requirement R1 through R3 should be no higher than medium. To be higher than medium, a violation of the requirement would have to lead directly to cascading, instability or system separation. Power swings were not direct causes to the August 14, 2003 blackout but rather occurred after other events had already happened.</p> <p><i>Response: Thank you for your comment.</i></p> <p>(2) We disagree with the VRF for Requirement R4. Requirement R4 is an administrative requirement to update paperwork (i.e. update the CAP). It does not and should compel completion of the CAP because it is impossible to complete construction by a certain date due to the unpredictability (e.g. weather, logistical, legal, or operational delays) of issues that delays construction.</p>

Organization	Yes or No	Question 5 Comment
		<p>Response: Requirement R6 (previously R4) requires the Corrective Action Plan to be updated in order to show progress and for measurability of implementation. No change made.</p> <p>(3) We cannot agree with the VSLs because we do not agree with the requirements. Furthermore, the VSLs anticipate that the only violation that could occur is a time violation. VSLs that are not just time-based need to be written.</p> <p>Response: The Violation Severity Levels are both performance of the activity and time-based. Generally, the first VSLs (i.e., Low, Med, High) are for performance that was done, but late. The VSL of Severe is generally for failure to perform the reliability activity. No change made.</p>
PPL NERC Registered Affiliates	No	<p>The VSL for failure to identify an Element in accordance with R2 needs to take into account the potential impossibility of performing a look-back to Jan. 1, 2003, as stated above.</p> <p>Response: The "January 1, 2003" date has been removed from the standard. Requirement R2 (and new R3) are based on actual Disturbances that occur after the Effective Date of the standard. Change made.</p>
BC Hydro	No	<p>BC Hydro does not agree with R1 and R2, therefore do not agree with violation risk factors or violation severity levels.</p> <p>Response: Thank you for your comment.</p>
Florida Municipal Power Agency	No	<p>Since a standard is not needed in the first place, then, there should be no VRF above a Low. All requirements should be Planning Horizon and none in Operating Horizon.</p> <p>Response: Thank you for your comment.</p>
Arizona Public Service Co.	No	<p>APS suggests the timelines associated with the proposed VSL for Requirement 1 be adjusted to a longer time period if drafting team addresses the APS issue associated with the timing requirements on R1.</p> <p>Response: The drafting team made revisions to the timing of Requirement R1 and did not make changes to the incremental timing of violations for tardiness in the Violation Severity Level (VSL) for Requirement</p>

Organization	Yes or No	Question 5 Comment
		R1 based on the NERC Guidelines for VSLs.
Public Service Enterprise Group	No	<p>We disagree with the need for this standard.</p> <p>Response: Thank you for your comment. Please see response in Question 1 above.</p>
Peak Reliability	No	<p>Peak Reliability disagrees with the assignment of the multiple VSL's for Requirements R1, R2 and R3 because the proposed VSLs simply increase the penalty for tardiness. Any delay in identifying and element is a reliability concern. Recommend changing the VSL as follows:</p> <p>R1 Lower VSL: The responsible entity identified an Element and provided notification in accordance with Requirement R1, but was late by less than or equal to 7 calendar days.</p> <p>R1 Severe VSL: The responsible entity failed to identify an Element or to provide notification in accordance with Requirement R1 or was late by more than 7 calendar days.</p> <p>Response: The drafting team contends that based on the revision to allow the Planning Coordinator a complete calendar year to identify Elements that meet the criteria, an incremental Violation Severity Level (VSL) meets the NERC Guidelines with the failure to identify an Element having a VSL of Severe (i.e., binary). No change made.</p> <p>R2 Lower VSL: The responsible entity identified Element in accordance with Requirement R2, but was late by less than or equal to 7 calendar days.</p> <p>R2 Severe VSL: The responsible entity failed to identify an Element in accordance with Requirement R2 or was late by more than 7 calendar days.</p> <p>Response: The drafting team contends that based on the revisions made to Requirement R2 and the new R3, an incremental Violation Severity Level (VSL) meets the NERC Guidelines with the failure to notify the Planning Coordinator of an Element having a VSL of Severe (i.e., binary). No change made.</p> <p>R3 Lower VSL: The responsible entity performed one of the options in accordance with Requirement R3, but was less than or equal to 7 calendar days late.</p>

Organization	Yes or No	Question 5 Comment
		<p>R# Severe VSL: The responsible entity performed one of the options in accordance with Requirement R3, but was more than 7 calendar days late or the responsible entity failed to perform one of the options in accordance with Requirement R3.</p> <p>Response: The drafting team contends that based on the revisions made to Requirement R4 (previously R3), an incremental Violation Severity Level (VSL) meets the NERC Guidelines with the failure to evaluate its load-responsive protective relays having a VSL of Severe (i.e., binary). No change made.</p>
American Electric Power	No	<p>The severe VSL for R1 and R2 could be interpreted that a lack of applicable elements would be a violation. It should be revised so that it is clear that the entity owns an element that should have been identified, but did not identify that element.</p> <p>Response: The drafting team modified the Violation Severity Levels (VSL) for Requirements R1, R2, and the new R3 to address the concern.</p>
Tacoma Power	No	<p>Tacoma Power disagrees with the need for this standard. In particular, Tacoma Power has significant concerns with Requirements R1 and R2. It is therefore difficult to provide additional feedback on the VRFs and VSLs at this time.</p> <p>Response: Thank you for your comment.</p>
New York Power Authority	No	<p>We do NOT agree with the need for this standard.</p> <p>Response: Thank you for your comment.</p>
Oncor Electric Delivery LLC	No	<p>See response to question #1.</p> <p>Response: Thank you for your comment. Please see the response in Question 1.</p>
ITC	No	<p>R2 and R3 essentially leave an entity with 11 months to meet compliance. The Violation Severity Levels should be longer, considering the timeframe allowed to complete the task and the minimal risk to the BES.</p>

Organization	Yes or No	Question 5 Comment
		<p>Response: The drafting team asserts that the incremental value for tardiness is consistent with the time periods provided in the revisions to the Requirement. The Violation Severity Levels have been updated to align with the Requirement changes.</p>
Xcel Energy	No	<p>As recommended above, it is recommended that the frequency to complete the tasks related to this standard to be changed to every 4 years. It is also recommended that the window for completing the tasks change to 3 to 6 months. The proposed VSL should change accordingly.</p> <p>Response: The drafting team asserts that the incremental value for tardiness is consistent with the time periods provided in the revisions to the Requirement. The Violation Severity Levels have been updated to align with the Requirement changes.</p>
MRO NERC Standards Review Forum	Yes	
Tennessee Valley Authority	Yes	
Southern Company; Southern Company Services, Inc.; Alabama Power Company; Georgia Power Company; Gulf Power Company; Mississippi Power Company; Southern	Yes	<p>The requirement language should be finalized before establishing VRFs, VSLs. and measures.</p> <p>Response: Thank you for your comments.</p>

Organization	Yes or No	Question 5 Comment
Company Generation; Southern Company Generation and Energy Marketing		
Dominion	Yes	
FirstEnergy Corp.	Yes	
Florida Power & Light	Yes	
Duke Energy	Yes	
Puget Sound Energy	Yes	
Bureau of Reclamation	Yes	
Luminant Generation Company LLC	Yes	
Ingleside Cogeneration LP	Yes	
Massachusetts Attorney General	Yes	

Organization	Yes or No	Question 5 Comment
MidAmerican Energy Company	Yes	
Consolidated Edison, Inc.	Yes	
American Transmission Company, LLC	Yes	
Manitoba Hydro	Yes	
Independent Electricity System Operator	Yes	
David Kiguel	Yes	
ISO New England	Yes	
Exelon	Yes	
Texas Reliability Entity	Yes	
Northeast Utilities	Yes	
Idaho Power Co.	Yes	



Organization	Yes or No	Question 5 Comment
Southern California Edison Company	Yes	
Public Utility District No. 1 of Cowlitz County, WA	Yes	
Salt River Project	Yes	
PacifiCorp		No comment
DTE Electric		No comment

6. Does PRC-026-1, Application Guidelines and Technical Basis provide sufficient guidance, basis for approach, and examples to support performance of the requirements? If not, please provide specific detail that would improve the Guidelines and Technical Basis

Summary Consideration: Over 75% of commenters disagreed that the PRC-026-1, Application Guidelines and Technical Basis provide sufficient guidance, basis for approach, and examples to support performance of the Requirements. Many of the comments here were also raised in previous questions. A summary of those are provided in other questions summaries. Among other things, the drafting team greatly enhanced the Guidelines and Technical Basis to include numerous examples, calculations, and figures.

Organization	Yes or No	Question 6 Comment
Northeast Power Coordinating Council	No	<p>In the Application Guidelines, the wording under Requirement 2 for credible event is very ambiguous and needs specificity.</p> <p>Response: The term “credible” has been removed from the standard. The drafting team clarified Requirement R1, Criterion 3 by framing the criterion in the present tense to refer to the current assessment(s). Islands caused by natural phenomena (i.e., Disturbances) are covered under Requirement R2. Change made.</p>
MRO NERC Standards Review Forum	No	<p>The NSRF believes there is some significant discussion in the guidelines and technical basis. However, we recommend that the SDT provide more clear explanation of all of the important parameters.</p> <p>Response: Thank you for your comments.</p>
SPP Standards Review Group	No	<p>Requirement R2 calls for the responsible entities to identify Elements based on performance since January 1, 2003 which is before the effective date of the standard. During the webinar, the SDT indicated that although this requirement was included in the standard, it was not the intent of the SDT to hold the responsible entities accountable for this data. This exception should be included in the Application Guideline and especially in the RSAW.</p> <p>Response: The “January 1, 2003” date has been removed from the standard. Requirement R2 (and new R3) are based on actual Disturbances that occur after the Effective Date of the standard. Change made.</p>

Organization	Yes or No	Question 6 Comment
		<p>One-line diagrams for the examples in the explanations for Requirements R1 and R2 would be helpful.</p> <p>Response: The drafting team added clarifications and examples in the Guidelines and Technical Basis for Generator Owners. Change made.</p> <p>In the 3rd paragraph on Page 15, the SDT attempts to clarify the 2nd option under Requirement R3. The 1st sentence in the paragraph does just that. However, the next two sentences seem to go beyond the requirement by expanding the scope of the requirement. We propose to delete these last two sentences.</p> <p>Response: This problem has been addressed due to other changes to the Requirements.</p>
ACES Standards Collaborators	No	<p>(1) In general the guidelines provide a good explanation; however, we do identify some suggested improvements below.</p> <p>(2) We suggest modifying the end of the “Applicability” section on page 13 to clearly state that these load-serving facilities by definition would not be part of the BES. Thus, standards would not apply.</p> <p>Response: Section 4.2, Facilities provides sufficient language that the standard is applicable to only “BES Elements.” No change made to the standard based upon the comment.</p> <p>(3) The last sentence of the “Requirement R1” section on page 14 is too vague. As written, it could be interpreted that the PC and TP must include any Elements identified in the Planning Assessment for any reason (i.e. including non-power swing issues). This is inaccurate. Part 4 of the requirement is very specific to only those Elements with relays that trip due to stable power swings as identified in studies. Please update the guidelines to match the language of the requirement more closely.</p> <p>Response: The drafting team contends the requirement only applies to inclusions that are based on Elements tripping on stable or unstable power swings. The Guidelines and Technical Basis has changed significantly and provide additional guidance for Criterion 4. The sentence noted above has been removed. Change made.</p>
FirstEnergy Corp.	No	<p>It would be most helpful to specify protective functions (e.g., 78, 21, 67, 40?) to be included in this analysis, similar to what was done with the Criteria Tables in PRC-025. If the reference to “load-responsive</p>

Organization	Yes or No	Question 6 Comment
		<p>protective relay” in PRC-026-1 R2 means the same as where this terminology is used (and defined) in PRC-025, the scope of work required for the detailed analysis specified in PRC-026-1 R3 is quite significant.</p> <p>Response: The term “load-responsive protective relays” is widely understood and is any protective functions which could trip with or without time delay, on load current. A clarification has been provided in PRC-026-1 – Attachment A. Change made.</p> <p>Technical resources to perform this analysis on each applicable relay could be difficult for many GOs to commit or obtain, and it would be difficult to accomplish the analyses in a short timeframe. One year is unrealistic, especially considering the concern stems from an incident that occurred nearly eleven years ago.</p> <p>Response: The “January 1, 2003” date has been removed from the standard. Requirement R2 (and new R3) are based on actual Disturbances that occur after the Effective Date of the standard. Events that occur will be reported to the Planning Coordinator in order to maintain the Element as an “identified Element.” Change made.</p> <p>This requirement should also be worded in such a way as to be sensitive to GOs operating in a competitive environment, where FERC Standard of Conduct issues make it difficult if not impossible to even know about power swings or other disturbances on the power system.</p> <p>Response: The drafting team contends that the Protection System owner (i.e., Generator Owner and Transmission Owner) is the appropriate entity for reviewing operations. No change made.</p> <p>Please define “stable power swing”. The diagrams (“Figures”) in the Application Guidelines appear to be typical.</p> <p>Response: The drafting team provided the general definitions in the Guidelines and Technical Basis. Change made.</p> <p>Is there enough information contained in the Application Guidelines that a GO can determine Power Swing Stability Boundaries for each specific application?</p> <p>Response: The Generator Owner was moved from Requirement R2 to the new Requirement R3 in order to</p>

Organization	Yes or No	Question 6 Comment
		remove the “islanding” criteria for Generator Owners. Change made.
PPL NERC Registered Affiliates	No	<p>In addition to our comments elsewhere in this document, the term, “load-responsive protective relays,” needs definition, especially since its meaning appears to change from one standard to another. We view “out-of-step” devices as not being among the load-responsive protective relays governed by PRC-025-1, for example, but being included under PRC-026-1. Is the list on p.23 of the Application Guidelines meant to be exclusive?</p> <p>Response: The term “load-responsive protective relays” is widely understood and is any protective functions which could trip with or without time delay, on load current. A clarification has been provided in PRC-026-1 – Attachment A. Change made.</p> <p>The drafting team provided both inclusions (“including, but not limited to”) and specific exclusions.</p>
Duke Energy	No	<p>On page 16 of the Application Guideline and Technical Basis document, paragraph 3 states, “...the Element passes the evaluation (Figures 6 and 7).” However, Figure 7 on page 23 states, “This Element does not pass the Requirement R3 evaluation.” It appears that Figure 7 is incorrect with the statement on page 16.</p> <p>Response: The drafting team has rewritten of the Guidelines and Technical Basis to address inconsistencies, errors, and lack of detail. Change made.</p>
BC Hydro	No	<p>The technical basis should be improved to apply only to cases where stable power swings have historically caused undesirable tripping of transmission lines.</p> <p>Response: The drafting team asserts that the standard is proactively addressing the risk of load-responsive protective relays applied on Elements that are expected to have the greatest risk of exposure</p>

Organization	Yes or No	Question 6 Comment
		to power swings. The standard is based on guidance from the NERC System Protection and Control Subcommittee (SPCS) <i>Protection System Response to Power Swings</i> , August 2013 <sup>11</sup> (PSRPS Report) and includes Elements that trip during future events. No change made.
DTE Electric	No	<p>Paragraph four on Page 23 of 61 of the PSRPS Report states that current-only based protection is immune to operating during power swingw, but the Application to Generator Owners paragraph on page 23 of 25 of the draft standard implies that time overcurrent relays are subject to incorrect operation caused by stable power swings. Perhaps this could be clarified.</p> <p>Response: The PSRPS Report pg. 23 states:</p> <p><i>“ Although current-only-based protection is immune to operating during power swings, exclusive use of current-only-based protection is not practical and would reduce dependability of tripping for system faults and unstable power swings. A power system with no remote backup protection is susceptible to uncleared faults and the inability to separate during unstable power swings during extreme system events. Although current-only-based protection is secure for stable power swings and can be used on lines which require tripping on out-of-step conditions, additional separate out-of-step protection is required. Application of impedance-based backup protection and, where necessary, out-of-step protection, reintroduces the need to discriminate between stable and unstable power swings.”</i></p> <p>The drafting team understands the section above to refer to line current differential schemes which are immune to power swings and not phase overcurrent schemes that are applicable to the standard. No change made.</p> <p>Since relay engineers are typically not familiar with transient stability studies, it would be helpful if more examples were provided for specific generator relay types that would be prone to operate for power</p>

<sup>11</sup> NERC System Protection and Control Subcommittee. *Protection System Response to Power Swings*. August 2013: [http://www.nerc.com/comm/PC/System%20Protection%20and%20Control%20Subcommittee%20SPCS%2020/SPCS%20Power%20Swing%20Report\\_Final\\_20131015.pdf](http://www.nerc.com/comm/PC/System%20Protection%20and%20Control%20Subcommittee%20SPCS%2020/SPCS%20Power%20Swing%20Report_Final_20131015.pdf).

Organization	Yes or No	Question 6 Comment
		<p>swings.</p> <p>Response: The drafting team added clarifications and examples in the Guidelines and Technical Basis for Generator Owners. Change made.</p>
Luminant Generation Company LLC	No	<p>The Application Guide should include examples for Generator Owners using distance relays. The example should provide illustrations of transient stability R-X plots in the time domain provided by the Transmission Planner in a format that allows the Transmission Owner and Generation Owner to plot distance relay settings.</p> <p>Response: The drafting team added clarifications and examples in the Guidelines and Technical Basis for Generator Owners. Change made.</p>
Public Service Enterprise Group	No	<p>We disagree with the need for this standard.</p> <p>Response: Thank you for your comment. Please see response in Question 1 above.</p>
American Electric Power	No	<p>The Application Guidelines and Technical Basis section makes a number of assumptions and expectations, which would be difficult to prove. For example, "If PSB is applied, it is expected that the relays were set in consultation with the Transmission Planner to verify maximum slip rates." Does such a quote imply an obligation to prove such consultation took place? This section should not imply or specify any obligations not contained elsewhere in the requirements.</p> <p>Response: The drafting team removed this text and notes the Guidelines and Technical Basis do not obligate the entity under the standard. Change made.</p>
Consolidated Edison, Inc.	No	<p>1. In the Application Guidelines, the wording under Requirement 2 for "credible event" is very open-ended.</p> <p>Response: The term "credible" has been removed from the standard. The drafting team clarified Requirement R1, Criterion 3 by framing the criterion in the present tense to refer to the current assessment(s). Islands caused by natural phenomena (i.e., Disturbances) are covered under Requirement</p>

Organization	Yes or No	Question 6 Comment
		<p>R2. Change made.</p> <p>2. An example of how line differential protection would be treated with respect to Requirement 3 would be helpful. See the comment above in Question 4.</p> <p>Response: The drafting team added an exclusion for “current differential” elements to PRC-026-1 – Attachment A. Change made.</p>
American Transmission Company, LLC	No	<p>ATC believes there is some significant discussion in the guidelines and technical basis, however, recommends that the SDT provide more clear explanation of all of the important parameters.</p> <p>Response: The drafting team has provided additional information in the Guidelines and Technical Basis about the PRC-026-1 - Attachment B Criteria. Change made.</p>
Tacoma Power	No	<p>: Tacoma Power disagrees with the need for this standard. In particular, Tacoma Power has significant concerns with Requirements R1 and R2. The Application Guidelines and Technical Basis do not provide sufficient clarification related to these two requirements.</p> <p>Response: The drafting team has rewritten of the Guidelines and Technical Basis to address inconsistencies, errors, and lack of detail. Change made.</p>
Ameren	No	<p>These are generally well written considering this complex situation that we feel is very rare, but we do have the following recommendations for the drafting team:</p> <p>(1) The variables in Figure 2 need to be defined;</p> <p>Response: The figures have been cleaned up and clarified. Change made.</p> <p>(2) The issue of aligning the planning assessment time horizon with present Protection System settings (see our 2nd comment Q1) needs to be clarified;</p> <p>Response: Requirement R1 has been revised to only include the Planning Coordinator and due to this revision, the Criterion that identify Elements is now specifically assigned the Time Horizon: Long-term</p>



Organization	Yes or No	Question 6 Comment
		<p>Planning. In the event that a Corrective Action Plan (CAP) is necessary based on future system conditions, the CAP can specify a timeframe that does not enact changes until those system conditions require modification. An example has been added to clarify this scenario in the Guidelines and Technical Basis. Change made.</p> <p>(3) On page 24 change “the generator unsaturated generator X”d,” to “the generator saturated generator transient reactance X’d,” because transient time constant aligns better with power swing timeframe, and faults most often are the triggering event in such power swing scenarios (also see Reimert text pages 40, 289, 291, and particularly bottom of page 302).</p> <p>Response: The drafting team made a modification to allow entities the option of using transient or sub-transient reactance. The drafting team clarified that the “saturated” (transient or sub-transient) reactance is used. Change made.</p> <p>(4) On page 23 add “Overcurrent relays usually have long enough time delays that they can be excluded from consideration.” at the end of the ‘Application to Generator Owners’ section.</p> <p>Response: The drafting team did not add the proposed suggestion, but did add a clarification that standard is applicable to load-responsive protective relays (including overcurrent) which could trip instantaneously or with a time delay of less than 15 cycles. Change made.</p> <p>(5) To clarify when the simplified method instead of transient stability simulations can be used on page 24 in the last paragraph of the ‘Impedance Type Relays’ section change ‘is’ to ‘can’ and add “only” in the third line so it reads</p> <p style="padding-left: 40px;">“The simplified method used in the Application to Transmission Owners section can also be used here to provide a helpful understanding of a stable power swing on load-responsive protective relays for only those cases where the generator is connected to the transmission system and there are no infeed effects to be considered.”</p> <p>Response: The drafting team provided additional detail in the Guidelines and Technical Basis. Change made.</p>

Organization	Yes or No	Question 6 Comment
ISO New England	No	<p>While the Application Guidelines and Technical Basis provide guidance, we disagree with the current roles of functional entities to which the standard applies.</p> <p>Response: The Reliability Coordinator and Transmission Planner have been removed from the standard's Applicability; therefore, Requirement R1 is now only applicable to the Planning Coordinator as a single entity source of identifying Elements. The drafting team asserts that the Planning Coordinator has or has access to the knowledge including the wide-area view. Change made to the Requirement.</p>
New York Power Authority	No	<p>This proposed Standard would be better suited as a TPL, or OP Standard, not a PRC one. This is because the functions and study capabilities required for the Standard are done by Transmission Planning/Operations Organizations, and are not in the realm of Protective Relay Departments of a GO/TO.</p> <p>Response: The drafting team contends that there is not a practical way to specify the exact planning studies under the TPL standards that would result in the worst case stable power swing; similarly, under the TOP standards, operators would not be capable of taking action during the timeframe of a power swing. Therefore, the drafting team has established the graphical approach under the PRC body of NERC Reliability Standards by providing the standard's proposed PRC-026-1 - Attachment B Criteria that load-responsive protective relays must meet on an identified Element. No change made.</p>
Oncor Electric Delivery LLC	No	<p>Oncor agrees with the recommendation of the NERC PC (SCPS) and recommends if this has not been reviewed by NERC RISC, this may be an opportunity for the NERC Standard Committee (SC) to bring back to RISC for discussion in conjunction with the PSRPS technical document.</p> <p>Response: The NERC RISC evaluates emerging issues and this project is the result of FERC directives. The NERC RISC does not evaluate directives. No change made.</p> <p>If RISC and SC find the Standard should be developed, a clearer explanation as to what contingency the term "line out conditions" refers to should be included as this will determine the data source we use to generate our list of elements.</p> <p>Response: The phrase "line-out conditions" has been removed. Elements should be identified for</p>

Organization	Yes or No	Question 6 Comment
		Requirement R1 criterion regardless of the outage conditions that may be necessary to trigger enforcement of the System Operating Limits (SOL) or arming of the Special Protection System (SPS). Change made
Northeast Utilities	No	<p>1. In the Application Guidelines, the wording under Requirement 2 for “credible event” is very open-ended.</p> <p>Response: The term “credible” has been removed from the standard. The drafting team clarified Requirement R1, Criterion 3 by framing the criterion in the present tense to refer to the current assessment(s). Islands caused by natural phenomena (i.e., Disturbances) are covered under Requirement R2. Change made.</p> <p>2. An example of how line differential protection would be treated with respect to Requirement 3 would be helpful. See the comment above in Question 4.</p> <p>Response: The drafting team added an exclusion for “current differential” elements to PRC-026-1 – Attachment A. Change made.</p>
Public Utility District No. 1 of Cowlitz County, WA	No	<p>It is not clear how past events and Disturbance reports that must be considered in the identification of Elements will be archived and made available.</p> <p>Response: The “January 1, 2003” date has been removed from the standard. Requirement R2 (and new R3) are based on actual Disturbances that occur after the Effective Date of the standard. Events that occur will be reported to the Planning Coordinator in order to maintain the Element as an “identified Element.” Change made.</p>
Alliant Energy	No	In the Application Guide there is guidance provided for the determination of apparent impedance for Impedance Type Relays on page 23 of 25, under the “Application to Generator Owners” portion of the document. As noted in this section the process is complex. As such, we recommend adding a detailed example of how the Transmission Planner should conduct this analysis on the behalf of the Generation

Organization	Yes or No	Question 6 Comment
		<p>Owner.</p> <p>Response: The drafting team has rewritten this section of the Technical Basis and Guidelines.</p>
PacifiCorp	Yes	
Tennessee Valley Authority	Yes	
Dominion	Yes	
Florida Power & Light	Yes	
Puget Sound Energy	Yes	
Bonneville Power Administration	Yes	
Arizona Public Service Co.	Yes	
Bureau of Reclamation	Yes	
Ingleside Cogeneration LP	Yes	
Massachusetts	Yes	

Organization	Yes or No	Question 6 Comment
Attorney General		
MidAmerican Energy Company	Yes	
Manitoba Hydro	Yes	
Independent Electricity System Operator	Yes	
Exelon	Yes	
ITC	Yes	<p>The App Guide will be sufficient, considering the improvements mentioned in the webinar. In addition, we request more details regarding islanding scenarios and explanation of “credible” along the lines of our answer to Question 1.</p> <p>Response: The term “credible” has been removed from the standard. The drafting team clarified Requirement R1, Criterion 3 by framing the criterion in the present tense to refer to the current assessment(s). Islands caused by natural phenomena (i.e., Disturbances) are covered under Requirement R2. Change made.</p>
Idaho Power Co.	Yes	<p>In the present form of R1-R4</p> <p>Response: Thank you for your comment.</p>
Southern California Edison Company	Yes	
Salt River Project	Yes	

Organization	Yes or No	Question 6 Comment
Xcel Energy	Yes	

7. Do you agree with implementation period of the proposed standard based on the considerations listed in the Implementation Plan? If not, please provide a justification for changing the proposed implementation period

Summary Consideration: About two-thirds (64%) disagreed with the implementation period of the proposed standard based on the considerations listed in the Implementation Plan. The chief concern, from 12 comments by 56 stakeholders, related to the initial influx of Elements and performing the evaluations. To address this concern the implementation plan was modified. Requirements R1-R3, R5, and R6 all become effective 12 months following approval. An implementation of 36 months is provided in Requirement R4 to evaluate identified Elements pursuant to Requirement R1. The Planning Coordinator is to become compliant with the initial identification of Elements in Requirement R1 during the calendar year 12 calendar months after approval and perform Requirement R1 each calendar year thereafter.

Again, Requirement R4 (previously R3) will become effective 36 calendar months after approval of the standard. During the implementation of the standard, notifications (i.e., from R1-R3) are likely to occur prior to Requirement R4 becoming effective. Where notification under R1 or identification under Requirement R2 or R3 occurs prior to the Effective Date of Requirement R4, the 12 month time period in Requirement R4 will begin from the Effective Date of Requirement R4. Thereafter, entities will follow the 12 month time period in R4. The intention of the additional time for Requirement R4 to become effective is to handle the initial influx of notifications and identifications.

Organization	Yes or No	Question 7 Comment
MRO NERC Standards Review Forum	No	<p>The NSRF believes there may be many elements, questions or unexpected problems in preparing for the first compliance deadline. Therefore, 24 months may be more reasonable than 12 months.</p> <p>Response: Requirements R1-R3, R5, and R6 all become effective following approval and require evaluation under the time period allotted in Requirement R4 (previously R3) for any identified Elements. The Planning Coordinator is to become compliant with the initial identification of Elements in Requirement R1 during the calendar year after 12 calendar months of approval and perform Requirement R1 each calendar year thereafter.</p> <p>Requirement R4 (previously R3) will become effective 36 calendar months following approval of the standard. During the implementation of the standard, notifications (i.e., from R1-R3) are likely to occur prior to Requirement R4 becoming effective. Where notification under R1 or identification under Requirement R2 or R3 occurs prior to the Effective Date of Requirement R4, the 12 month time period in</p>

Organization	Yes or No	Question 7 Comment
		Requirement R4 will begin from the Effective Date of Requirement R4. Thereafter, entities will follow the 12 month time period in R4. The intention of the additional time for R4 to become effective is to handle the initial influx of notifications and identifications. Change made.
SPP Standards Review Group	No	<p>We would prefer to see the twelve months increased to twenty-four months to allow adequate time to complete all the studies and analyses that will be needed to comply with the standard.</p> <p>Response: Requirements R1-R3, R5, and R6 all become effective following approval and require evaluation under the time period allotted in Requirement R4 (previously R3) for any identified Elements. The Planning Coordinator is to become compliant with the initial identification of Elements in Requirement R1 during the calendar year after 12 calendar months of approval and perform Requirement R1 each calendar year thereafter.</p> <p>Requirement R4 (previously R3) will become effective 36 calendar months following approval of the standard. During the implementation of the standard, notifications (i.e., from R1-R3) are likely to occur prior to Requirement R4 becoming effective. Where notification under R1 or identification under Requirement R2 or R3 occurs prior to the Effective Date of Requirement R4, the 12 month time period in Requirement R4 will begin from the Effective Date of Requirement R4. Thereafter, entities will follow the 12 month time period in R4. The intention of the additional time for R4 to become effective is to handle the initial influx of notifications and identifications. Change made. Change made.</p>
ACES Standards Collaborators	No	<p>(1) We disagree with the implementation plan and believe that a staggered implementation is necessary. If the standard were approved such that it would become effective on March 1, 2016, the TO and GO would not have any Elements identified per R1 until approximately 10 months later in January 2017. How could they comply in 2016 with R3 when they don't have any Elements identified per R1?</p> <p>Response: Requirements R1-R3, R5, and R6 all become effective following approval and require evaluation under the time period allotted in Requirement R4 (previously R3) for any identified Elements. The Planning Coordinator is to become compliant with the initial identification of Elements in Requirement R1 during the calendar year after 12 calendar months of approval and perform Requirement</p>



Organization	Yes or No	Question 7 Comment
		<p>R1 each calendar year thereafter.</p> <p>Requirement R4 (previously R3) will become effective 36 calendar months following approval of the standard. During the implementation of the standard, notifications (i.e., from R1-R3) are likely to occur prior to Requirement R4 becoming effective. Where notification under R1 or identification under Requirement R2 or R3 occurs prior to the Effective Date of Requirement R4, the 12 month time period in Requirement R4 will begin from the Effective Date of Requirement R4. Thereafter, entities will follow the 12 month time period in R4. The intention of the additional time for R4 to become effective is to handle the initial influx of notifications and identifications. Change made. Change made.</p>
FirstEnergy Corp.	No	<p>This current situation has continued for 11 years and an implementation plan of 1 year is unrealistically short. Two years is more appropriate unless the period is modified to include only incidents which have occurred since the inception of NERC PRC-004 then 1 year would be reasonable.</p> <p>Response: Requirements R1-R3, R5, and R6 all become effective following approval and require evaluation under the time period allotted in Requirement R4 (previously R3) for any identified Elements. The Planning Coordinator is to become compliant with the initial identification of Elements in Requirement R1 during the calendar year after 12 calendar months of approval and perform Requirement R1 each calendar year thereafter.</p> <p>Requirement R4 (previously R3) will become effective 36 calendar months following approval of the standard. During the implementation of the standard, notifications (i.e., from R1-R3) are likely to occur prior to Requirement R4 becoming effective. Where notification under R1 or identification under Requirement R2 or R3 occurs prior to the Effective Date of Requirement R4, the 12 month time period in Requirement R4 will begin from the Effective Date of Requirement R4. Thereafter, entities will follow the 12 month time period in R4. The intention of the additional time for R4 to become effective is to handle the initial influx of notifications and identifications. Change made. Change made.</p>
PPL NERC Registered Affiliates	No	<p>It is not evident why applicable Elements owned by GOs require a new R3 analysis annually. Their calculations should remain valid until and unless impedances change significantly. We suggest that the TO</p>

Organization	Yes or No	Question 7 Comment
		<p>should provide a system impedance update annually (ref. comment #2 above), and a new study should be required of the GO only if the generator, GSU or system impedance changes by 10% or more.</p> <p>Response: The drafting team increased the Implementation Plan to three years to provide for the initial influx of identified Elements under Requirement R1. The evaluation of relays under Requirement R4 (previously R3) is to be performed “within 12 full calendar months of receiving notification of an Element ... where the evaluation has not been performed in the last three calendar years.” Change made.</p>
BC Hydro	No	<p>BC Hydro does not agree with implementation of the proposed standard at all.</p> <p>Response: Thank you for your comment.</p>
Puget Sound Energy	No	<p>As noted in question 4, the modeling of protective relays needed to evaluate the system will not be implemented by the proposed implementation date for the standard.</p> <p>Response: The drafting team asserts that the standard does not require the inclusion of relay models. Requirement R1 – Criterion 4 is not requiring a study, but the identification of any Element that was observed as tripping in the most recent Planning Assessment Response: The drafting team asserts that the standard does not require the inclusion of relay models. Requirement R1 – Criterion 4 is not requiring a study, but the identification of any Element that was observed as tripping in the most recent Planning Assessment. No change made.</p>
Bonneville Power Administration	No	<p>BPA feels 12 months is insufficient time for the initial implementation.</p> <p>Response: Requirements R1-R3, R5, and R6 all become effective following approval and require evaluation under the time period allotted in Requirement R4 (previously R3) for any identified Elements. The Planning Coordinator is to become compliant with the initial identification of Elements in Requirement R1 during the calendar year after 12 calendar months of approval and perform Requirement R1 each calendar year thereafter.</p> <p>Requirement R4 (previously R3) will become effective 36 calendar months following approval of the</p>

Organization	Yes or No	Question 7 Comment
		<p>standard. During the implementation of the standard, notifications (i.e., from R1-R3) are likely to occur prior to Requirement R4 becoming effective. Where notification under R1 or identification under Requirement R2 or R3 occurs prior to the Effective Date of Requirement R4, the 12 month time period in Requirement R4 will begin from the Effective Date of Requirement R4. Thereafter, entities will follow the 12 month time period in R4. The intention of the additional time for R4 to become effective is to handle the initial influx of notifications and identifications. Change made. Change made.</p>
<p>Arizona Public Service Co.</p>	<p>No</p>	<p>AZPS suggests the timeline for the implementation plan be increased to allow for two years for requirements one and two and requirements three and four be adjusted accordingly. APS believes significant effort will be required to identify relays that may qualify for inclusion.</p> <p>Response: Requirements R1-R3, R5, and R6 all become effective following approval and require evaluation under the time period allotted in Requirement R4 (previously R3) for any identified Elements. The Planning Coordinator is to become compliant with the initial identification of Elements in Requirement R1 during the calendar year after 12 calendar months of approval and perform Requirement R1 each calendar year thereafter.</p> <p>Requirement R4 (previously R3) will become effective 36 calendar months following approval of the standard. During the implementation of the standard, notifications (i.e., from R1-R3) are likely to occur prior to Requirement R4 becoming effective. Where notification under R1 or identification under Requirement R2 or R3 occurs prior to the Effective Date of Requirement R4, the 12 month time period in Requirement R4 will begin from the Effective Date of Requirement R4. Thereafter, entities will follow the 12 month time period in R4. The intention of the additional time for R4 to become effective is to handle the initial influx of notifications and identifications. Change made. Change made.</p>
<p>Public Service Enterprise Group</p>	<p>No</p>	<p>We disagree with the need for this standard.</p> <p>Response: Thank you for your comment. Please see response in Question 1 above.</p>
<p>Peak Reliability</p>	<p>No</p>	<p>The expectations of the RC need to be clarified, and until they are clarified, it is unclear whether the</p>

Organization	Yes or No	Question 7 Comment
		<p>implementation period is reasonable. It is unclear whether the annual list of Elements provided by the RC is intended to be a result of a new and different one-time analysis performed by the RC or TOP, or if the list of Elements is intended to be compiled over time as a result of ongoing operations planning analyses and real-time assessments already being performed. The RC performs many assessments throughout the Operations Planning horizon, Same-Day horizon, and Real-time horizons for expected and actual operating conditions. As related to the RC specifically, is the intent of R1 for the RC to continuously add to this list of Elements based on the results from all of these RC studies performed throughout the year, and to report this compiled list to the GOs and TOs once per calendar year? This approach would seem to add the most reliability benefit.</p> <p>Response: The Reliability Coordinator and Transmission Planner have been removed from the standard's Applicability; therefore, Requirement R1 is now only applicable to the Planning Coordinator as a single entity source of identifying Elements. The drafting team asserts that the Planning Coordinator has or has access to the knowledge including the wide-area view. The Planning Coordinator is believed to be the best single-source of information and not the Transmission Operator.</p> <p>Requirement R1 has been modified to state that at least once per calendar year the Elements in its area meeting the Requirement R1 criteria are to be identified. Requirement R1 is not intended to require new studies, but to identify Elements based on existing information. Change made.</p>
American Electric Power	No	<p>The implementation plan only allows the GO/TO 11 months to complete their initial R3 study of all Elements identified in R1. We believe the time allowed is too short for the initial implementation of the standard, as the GO/TO will need to research all Elements, not just those incrementally added from the previous year's planning analysis. The implementation plan should be revised to guarantee the GO/TO a minimum of at least 36 months to complete their initial R2 and R3 studies.</p> <p>The timing of the sequence as proposed in the standard is acceptable after the initial implementation. However, as currently written, the initial implementation plan does not guarantee adequate time for the applicable Entities to become compliant.</p> <p>Response: Requirements R1-R3, R5, and R6 all become effective following approval and require</p>

Organization	Yes or No	Question 7 Comment
		<p>evaluation under the time period allotted in Requirement R4 (previously R3) for any identified Elements. The Planning Coordinator is to become compliant with the initial identification of Elements in Requirement R1 during the calendar year after 12 calendar months of approval and perform Requirement R1 each calendar year thereafter.</p> <p>Requirement R4 (previously R3) will become effective 36 calendar months following approval of the standard. During the implementation of the standard, notifications (i.e., from R1-R3) are likely to occur prior to Requirement R4 becoming effective. Where notification under R1 or identification under Requirement R2 or R3 occurs prior to the Effective Date of Requirement R4, the 12 month time period in Requirement R4 will begin from the Effective Date of Requirement R4. Thereafter, entities will follow the 12 month time period in R4. The intention of the additional time for R4 to become effective is to handle the initial influx of notifications and identifications. Change made. Change made.</p>
<p>American Transmission Company, LLC</p>	<p>No</p>	<p>ATC believes there may be many elements, questions or unexpected problems in preparing for the first compliance deadline. Therefore, 24 months may be more reasonable than 12 months.</p> <p>Response: Requirements R1-R3, R5, and R6 all become effective following approval and require evaluation under the time period allotted in Requirement R4 (previously R3) for any identified Elements. The Planning Coordinator is to become compliant with the initial identification of Elements in Requirement R1 during the calendar year after 12 calendar months of approval and perform Requirement R1 each calendar year thereafter.</p> <p>Requirement R4 (previously R3) will become effective 36 calendar months following approval of the standard. During the implementation of the standard, notifications (i.e., from R1-R3) are likely to occur prior to Requirement R4 becoming effective. Where notification under R1 or identification under Requirement R2 or R3 occurs prior to the Effective Date of Requirement R4, the 12 month time period in Requirement R4 will begin from the Effective Date of Requirement R4. Thereafter, entities will follow the 12 month time period in R4. The intention of the additional time for R4 to become effective is to handle the initial influx of notifications and identifications. Change made. Change made.</p>

Organization	Yes or No	Question 7 Comment
Independent Electricity System Operator	No	
Tacoma Power	No	<p>Tacoma Power disagrees with the need for this standard. In particular, Tacoma Power has significant concerns with Requirements R1 and R2.</p> <p>Response: Please see the section at the beginning of this document called, “NERC Discussion on Proceeding(s) and Directives Regarding: Stable Power Swings” for a complete background. The SDT understands that NERC staff re-engaged FERC staff following the completion of the PSRPS Report and that the Commission still desired NERC to pursue its work to meet the directive. However, FERC staff was open to an approach designed by NERC. NERC staff has informally received positive feedback on the approach to address the regulatory directive. The directive itself was challenged by commenters prior to the issuance of Order No. 733 and was already the subject of multiple rehearing requests in the Order No. 733-A and Order No. 733-B proceedings. Similar arguments to the conclusions of the NERC System Protection and Control Subcommittee were advanced in these FERC proceedings.</p> <p>See responses to Question 1 comments on R1 and R2.</p>
Ameren	No	<p>(1) We request that the SDT provide a 1 year implementation period for R1 and R2 combined, followed by a 2 year implementation period for R3.</p> <p>(2) We believe that this standard poses a considerable burden on the TO and GO and the first pass may be a significant amount of work.</p> <p>Response: Requirements R1-R3, R5, and R6 all become effective following approval and require evaluation under the time period allotted in Requirement R4 (previously R3) for any identified Elements. The Planning Coordinator is to become compliant with the initial identification of Elements in Requirement R1 during the calendar year after 12 calendar months of approval and perform Requirement R1 each calendar year thereafter.</p>

Organization	Yes or No	Question 7 Comment
		<p>Requirement R4 (previously R3) will become effective 36 calendar months following approval of the standard. During the implementation of the standard, notifications (i.e., from R1-R3) are likely to occur prior to Requirement R4 becoming effective. Where notification under R1 or identification under Requirement R2 or R3 occurs prior to the Effective Date of Requirement R4, the 12 month time period in Requirement R4 will begin from the Effective Date of Requirement R4. Thereafter, entities will follow the 12 month time period in R4. The intention of the additional time for R4 to become effective is to handle the initial influx of notifications and identifications. Change made. Change made.</p>
ISO New England	No	<p>Given that the currently proposed scope of the standard is very broad, twelve months is not a long enough timeframe to become compliant with the requirements of this standard, which will create additional workload for the functional entities subject to the standard. ISO New England suggests 36 months.</p> <p>Response: Requirements R1-R3, R5, and R6 all become effective following approval and require evaluation under the time period allotted in Requirement R4 (previously R3) for any identified Elements. The Planning Coordinator is to become compliant with the initial identification of Elements in Requirement R1 during the calendar year after 12 calendar months of approval and perform Requirement R1 each calendar year thereafter.</p> <p>Requirement R4 (previously R3) will become effective 36 calendar months following approval of the standard. During the implementation of the standard, notifications (i.e., from R1-R3) are likely to occur prior to Requirement R4 becoming effective. Where notification under R1 or identification under Requirement R2 or R3 occurs prior to the Effective Date of Requirement R4, the 12 month time period in Requirement R4 will begin from the Effective Date of Requirement R4. Thereafter, entities will follow the 12 month time period in R4. The intention of the additional time for R4 to become effective is to handle the initial influx of notifications and identifications. Change made. Change made.</p>
New York Power Authority	No	<p>Implementation periods should be consistent with the more relevant approach described in the PSRPS technical document.</p>

Organization	Yes or No	Question 7 Comment
		<p>Response: The drafting team modified the Implementation Plan (to 36 months) and several Requirements to provide additional time to reduce the burden. Also, the standard is consistent with the PSRPS Report which recommends a focused approach to identifying Elements that are most susceptible to power swings and therefore reduces the financial burden by not requiring all relays to be in scope. Changes made.</p>
<p>Oncor Electric Delivery LLC</p>	<p>No</p>	<p>Please see response #1, #6 and #10</p> <p>Response: Thank you for your comment. Please see responses to your comments in Questions 1, 6, and 10.</p>
<p>Idaho Power Co.</p>	<p>No</p>	<p>The requirements need work before an implementation plan can be defined. It should be adjusted based on changes proposed in #4.</p> <p>Response: Thank you for your comment. Please see the response in Question #4.</p>
<p>Xcel Energy</p>	<p>No</p>	<p>The implementation window and the implementation frequency is unnecessarily aggressive as powers system dynamics do not changes as fast. Four year frequency and 3 to 6 months implementation window are reasonable.</p> <p>R1 and R2 should be released earlier for the initial completion of R3. Additional time may be required to ensure appropriate relays are installed in the field.</p> <p>Response: Requirements R1-R3, R5, and R6 all become effective following approval and require evaluation under the time period allotted in Requirement R4 (previously R3) for any identified Elements. The Planning Coordinator is to become compliant with the initial identification of Elements in Requirement R1 during the calendar year after 12 calendar months of approval and perform Requirement R1 each calendar year thereafter.</p> <p>Requirement R4 (previously R3) will become effective 36 calendar months following approval of the standard. During the implementation of the standard, notifications (i.e., from R1-R3) are likely to occur prior to Requirement R4 becoming effective. Where notification under R1 or identification under</p>



Organization	Yes or No	Question 7 Comment
		<p>Requirement R2 or R3 occurs prior to the Effective Date of Requirement R4, the 12 month time period in Requirement R4 will begin from the Effective Date of Requirement R4. Thereafter, entities will follow the 12 month time period in R4. The intention of the additional time for R4 to become effective is to handle the initial influx of notifications and identifications.</p> <p>The standard is requiring that a CAP be created to modify the relaying to increase its security for stable power swings. It also requires the CAP to be implemented, but it does not state specific time frames for relay replacements to be done. Change made.</p>
PacifiCorp	Yes	
Tennessee Valley Authority	Yes	
Southern Company; Southern Company Services, Inc.; Alabama Power Company; Georgia Power Company; Gulf Power Company; Mississippi Power Company; Southern Company Generation; Southern Company Generation and Energy Marketing	Yes	<p>Yes, provided the R2 review period begins with the enforcement date of the standard looking forward.</p> <p>Response: The "January 1, 2003" date has been removed from the standard. Requirement R2 (and new R3) are based on actual Disturbances that occur after the Effective Date of the standard. Change made.</p>

Organization	Yes or No	Question 7 Comment
Dominion	Yes	
Duke Energy	Yes	
Bureau of Reclamation	Yes	
Luminant Generation Company LLC	Yes	
Ingleside Cogeneration LP	Yes	
Massachusetts Attorney General	Yes	
MidAmerican Energy Company	Yes	
Consolidated Edison, Inc.	Yes	
Manitoba Hydro	Yes	
David Kiguel	Yes	
Exelon	Yes	

Organization	Yes or No	Question 7 Comment
Texas Reliability Entity	Yes	
Northeast Utilities	Yes	
Southern California Edison Company	Yes	
Public Utility District No. 1 of Cowlitz County, WA	Yes	
Salt River Project	Yes	
DTE Electric		No comment

8. If you are aware of any conflicts between the proposed standard and any regulatory function, rule, order, tariff, rate schedule, legislative requirement, or agreement please identify the conflict here.

Summary Consideration: No conflicts between the proposed standard and any regulatory function, rule, order, tariff, rate schedule, legislative requirement, or agreement were identified.

Organization	Question 8 Comment
FirstEnergy Corp.	<p>In a competitive/unregulated environment a GO does not have access to the information pertaining to power swings (stable or otherwise) due to the FERC Standard of Conduct. Therefore the GO would not know the cause of a relay operation.</p> <p>Response: Thank you for your comment.</p>
Luminant Generation Company LLC	<p>NERC standards requirements should not reference data that predates the approval of the standard; therefore, rendering the Requirement R2 January 2003 date unenforceable.</p> <p>Response: The "January 1, 2003" date has been removed from the standard. Requirement R2 (and new R3) are based on actual Disturbances that occur after the Effective Date of the standard. Change made.</p>
Dominion	No
Consolidated Edison, Inc.	No
Northeast Utilities	No
DTE Electric	No comment
Northeast Power Coordinating Council	No.

Organization	Question 8 Comment
PPL NERC Registered Affiliates	No
ITC	No
Salt River Project	None
CHPD - Public Utility District No. 1 of Chelan County	<p>R1.2 - Is this an SOL for the planning (FAC-010) or operating (FAC-011) horizon? This requirement seems to be duplicating, at least in part, FAC-014 R6 (The Planning Authority shall identify the subset of multiple contingencies (if any), from Reliability Standard TPL-003 which result in stability limits.). SOLs are generally established to facilitate performance under a NERC TPL Category B performance. Select NERC TPL category C and limited D criteria are added by the WECC regional criteria.</p> <p>Response: Requirement R1, Criterion 1 and 2 address operating limits associated with angular stability limits; therefore, System Operating Limits (SOL) specified in Requirement R1, Criterion 2 includes both operations and planning horizons. In the event that a Corrective Action Plan (CAP) is necessary based on future system conditions, the CAP can specify a timeframe that does not enact changes until those system conditions require modification. An example has been added to clarify this scenario in the Guidelines and Technical Basis. Change made.</p> <p>R1.3 - TPL studies require transient stability simulations, not angular stability simulations. There is no standard that requires angular stability simulations. There is no mention of angular stability simulations in FAC-010, FAC-011, or the new TPL-001-4 either.</p> <p>Response: The drafting team contends that a System Operating Limit (SOL) as stated in Requirement R1 is in place to prevent angular instability. The standard addresses Elements associated with an SOL as an Element that would be susceptible to a power swing. No change made.</p> <p>R1.4 - WECC is slowly coming on board with this as a result of the San Diego outage and is adding</p>

Organization	Question 8 Comment
	<p>overcurrent relays to system models at this time. However, the relay tripping addressed in this proposed standard may also occur by distance or other elements, which are not required to be modeled in WECC at this time in its base case process. There is also a lack of a performance category for these reporting requirements (such as for Category B and C events). Performance issues may show up for extreme Category D events in the assessment, but in the language as it stands, these must also be identified and the GO and TO notified even for category D extreme events. This is a significant departure from traditional practice, which emphasizes category B and C issue communication. In the existing TPL standards, severe power swings are considered a Category D.14 event.</p> <p>Response: The drafting team asserts that the standard does not require the inclusion of relay models. Requirement R1, Criterion 4 is not requiring a study, but the identification of any Element that was observed as tripping in the most recent Planning Assessment pursuant to TPL-001-4, R4, Part 4.3.1.3 – “Tripping of Transmission lines and transformers where transient swings cause Protection System operation based on generic or actual relay models” which becomes effective January 1, 2015 (U.S.). Other clarifying changes were made to Requirement R1, Criterion 4.</p>
SPP Standards Review Group	<p>We are not aware of any conflicts between the proposed standard and any regulatory function, rule, order, tariff, rate schedule, legislative requirement, or agreement.</p> <p>Response: Thank you for your comment.</p>
Southern Company: Southern Company Services, Inc.; Alabama Power Company; Georgia Power Company; Gulf Power Company; Mississippi Power Company; Southern Company Generation; Southern Company Generation and Energy Marketing	<p>We are not aware of any conflicts.</p> <p>Response: Thank you for your comment.</p>

Organization	Question 8 Comment
SMUD/BANC	YES! The requirement R2 is particularly unacceptable as it requires data for pre June 18, 2007; effective date of Order 693 standards.  Response: Thank you for your comment.
Xcel Energy	No

9. If you are aware of the need for a regional variance or business practice that should be considered with this phase of the project, please identify it here:

Summary Consideration: No need for a regional variance or business practice that should be considered with this phase of the project was identified.

Organization	Question 9 Comment
Dominion	No
Consolidated Edison, Inc.	No
ITC	No
Northeast Utilities	No
DTE Electric	No comment
Northeast Power Coordinating Council	No
PPL NERC Registered Affiliates	No
FirstEnergy Corp.	None
Salt River Project	None
Tacoma Power	Tacoma Power disagrees with the need for this standard. However, assuming FERC does not provide relief from its directive to develop this standard, a regional variance should be considered, at least for WECC. The footprint of a typical Planning Coordinator or Transmission Planner in WECC may not be large enough to adequately perform the desired assessments in the



Organization	Question 9 Comment
	<p>planning horizon. Instead, it may be more effective to perform this analysis more regionally. The Reliability Coordinator may have a large enough vantage, but most of their focus is in the operating horizon.</p> <p>Response: Thank you for your comment.</p>
BC Hydro	<p>The WECC region should be exempt from this rule. In this region, transmission power along many lines is subject to stability limits. It is an unnecessary use of resources to check the stability of protection systems on so many lines, considering there have been a negligible number of undesirable trips on stable power swings.</p> <p>Response: The drafting team asserts that it has provided the criteria for identifying Elements susceptible to power swings that are consistent with the PSRPS Report. The proposed standard does not require entities to check the stability of any Protection Systems. Notification of the identified Elements is required to be provided to the respective Generator Owner and Transmission Owner for evaluation. No change made.</p>
SPP Standards Review Group	<p>No. We are not aware of any need for a regional variance or business practice.</p> <p>Response: Thank you for your comment.</p>
Southern Company: Southern Company Services, Inc.; Alabama Power Company; Georgia Power Company; Gulf Power Company; Mississippi Power Company; Southern Company Generation; Southern Company Generation and Energy Marketing	<p>No. We are not aware of any needs for exceptions.</p> <p>Response: Thank you for your comment.</p>
Bonneville Power Administration	<p>Western Interconnection has many long lines and remote generation.</p>

Organization	Question 9 Comment
	<p>Response: The drafting team asserts that it has provided the criteria for identifying Elements susceptible to power swings that are consistent with the PSRPS Report. The proposed standard does not require entities to check the stability of any Protection Systems. Notification of the identified Elements is required to be provided to the respective Generator Owner and Transmission Owner for evaluation. No change made.</p>
Xcel Energy	No

10. If you have any other comments on this Standard that you haven't already mentioned above, please provide them here

**Summary Consideration:** This question mainly generated comments that were submitted in the previous questions and are too varying and numerous to summarize coherently. There were two remarkable comments that generated a revision to the standard. The first concerns the assignment of Time Horizons. For Requirement R1, the drafting team eliminated the "Time-Horizon: Operation Planning" because it occurs on an annual basis and violating the Requirement beyond a year without mitigation would have little impact. Under the definition, "Time Horizon: Long-term Planning" is a planning horizon of one year or longer.

Furthermore, Requirement R2 (and the new R3) eliminated the "Time Horizon: Operation Planning" and kept "Time Horizon: Long-term Planning" because the information would be used by the PC in its annual assessments and violating the Requirement beyond a year and would have little impact to the Planning Coordinator's assessments. The drafting team eliminated "Time Horizon: Long-term Planning" and kept "Time Horizons: Operations Planning" for Requirement R4 (previously R3) and the new Requirement R5 because the associated timeframes comport with a "Time Horizon: Operations Planning." For Requirement R6 (previously R4), the drafting team eliminated the "Time Horizon: Operation Planning" because the failure to implement the CAP beyond a year without mitigation would have little impact when the length of CAPs that are generally implemented over several years.

The second remarkable comment relates to cost. The drafting team recognizes that cost is a consideration; however, this standard's approach narrowly focuses the reliability objectives to a select set of BES Elements (i.e., Requirement R1) to address the power swing concern where it is expected to be of greatest risk. This minimizes the cost to entities and compliance burden by not developing the standard to be applicable to the entire BES.

Organization	Question 10 Comment
David Kiguel	The PSRPS document, developed by industry experts and approved by the NERC Planning Committee, clearly disputes the FERC directive in Order No. 773 (Docket No. RM08-13-000), that was subsequently affirmed in Order Nos. 773-A and 773-B, that a standard is needed to ensure that load-responsive protective relays do not trip in response to stable power swings during non-Fault conditions. NERC's informational filing in Docket No. RM08-13-000 dated July 21, 2011 concluded that there is a need for a standard on stable power swings. This conclusion is the opposite of what the PSRPS document concluded. The SPCS concludes that a NERC Reliability Standard to address relay performance during stable swings is not needed, and could result in unintended adverse impacts to Bulk-Power System reliability. I support the recommendation that the NERC Standards Committee explore means to utilize the more recent PSRPS document to obtain relief from the aforementioned

Organization	Question 10 Comment
	<p>FERC directive that is driving this project.</p> <p>Response: Please see the section at the beginning of this document called, "NERC Discussion on Proceeding(s) and Directives Regarding: Stable Power Swings" for a complete background. The SDT understands that NERC staff re-engaged FERC staff following the completion of the PSRPS Report and that the Commission still desired NERC to pursue its work to meet the directive. However, FERC staff was open to an approach designed by NERC. NERC staff has informally received positive feedback on the approach to address the regulatory directive. The directive itself was challenged by commenters prior to the issuance of Order No. 733 and was already the subject of multiple rehearing requests in the Order No. 733-A and Order No. 733-B proceedings. Similar arguments to the conclusions of the NERC System Protection and Control Subcommittee were advanced in these FERC proceedings.</p>
<p>Southern Company; Southern Company Services, Inc.; Alabama Power Company; Georgia Power Company; Gulf Power Company; Mississippi Power Company; Southern Company Generation;</p>	<p>a) The phrase "continues to be credible" in R2 needs explanation. Is the intended meaning either 1) the trip was believed to be caused by the Disturbance, 2) a repeat trips susceptibility continues to be possible or likely, or 3) something else?</p> <p>Response: The term "credible" has been removed from the standard. The drafting team clarified Requirement R1, Criterion 3 by framing the criterion in the present tense to refer to the current assessment(s). Islands caused by natural phenomena (i.e., Disturbances) are covered under Requirement R2. Change made.</p> <p>b) Is the consequence of R2/M2 having to analyze and document every relay operation (trip) which occurs for determination of if it was caused by a system Disturbance? Also, do all system Disturbances have to be reviewed for possible relay (trip) operations, for subsequent validation of desired operation? The NERC glossary definition of a Disturbance is very much open-ended and not specifically defined in part 2:</p> <p style="padding-left: 40px;">"2. Any perturbation to the electric system."</p> <p>Response: The Requirement was structured to determine if the tripping was caused by a power swing, not a Disturbance. The drafting team revised Requirement R2 (and the new R3) to reference both stable and unstable power swing. This standard does not address the review of Protection System operations, only the actions required as a result of determining that tripping occurred due to a stable or unstable power swing. No change made.</p> <p>Is this requirement duplicative of PRC-004 relay mis-operation determination? Does PRC-026 subject entities to possible</p>

Organization	Question 10 Comment
<p>Southern Company Generation and Energy Marketing</p>	<p>violation of two standards for a single possible (lack of) action?</p> <p>Response: This standard does not address the review of Protection System operations, only the actions required as a result of determining that tripping occurred due to a stable or unstable power swing. The drafting team does not see this as duplicative of another standard. No change made.</p> <p>c) An annual requirement for R1, R2, and R3 seems excessive. Extended periodicity intervals or triggers from system topographic changes should be considered rather than annual reviews. For example, PRC-006 and PRC-010 prescribe evaluation intervals of 5 years for UVLS and UFLS. Five years seems to be a reasonable interval for this analysis.</p> <p>Response: The drafting team increased the Implementation Plan to three years to provide for the initial influx of identified Elements under Requirement R1. The evaluation of relays under Requirement R4 (previously R3) is to be performed “within 12 full calendar months of receiving notification of an Element ... where the evaluation has not been performed in the last three calendar years.” Change made.</p> <p>D) Does any specific item on the Identified Element list ever get removed from the list? The resolution of a review in a previous year should eliminate it from future reviews.</p> <p>Response: The drafting team notes that Elements do need to be identified when the Element no longer meets the Criteria in Requirement R1. No change made.</p>
<p>ACES Standards Collaborators</p>	<p>(1) Requirement R4 is unnecessary and inconsistent with the Reliability Assurance Initiative which is attempting to move NERC away from paper-driven compliance to reliability-driven compliance. The only practical violation of R4 will be a failure to update the paperwork. As written, if an implementation date slips, the TO or GO can update their CAP. We agree they should have the flexibility to do this since construction schedules nearly always have to be adjusted. Thus, if a milestone is not completed for any reason, a violation will not occur unless the CAP is not updated. How does this support reliability? Because it is not practical to require a TO or GO to complete their CAP by the dates established in the initial version due to unpredictable changes and unforeseen circumstances always faced in construction, the only real practical solution is to remove Requirement R4. NERC and the Regional Entities have the authority to request copies of the CAPs and progress reports and have other methods to encourage completion of CAPs if they are not satisfied with the progress.</p> <p>Response: The drafting team contends that updating actions and timeframes provides measurable evidence of</p>

Organization	Question 10 Comment
	<p>implementation of the CAP. In addition, implementation may require months or years to schedule and complete due to outages and other factors. No change made.</p> <p>(2) We are concerned that the RSAW is not consistent with the principle of the Reliability Assurance Initiative (RAI). RAI is intended to refocus NERC’s compliance efforts to be forward looking rather than backwards looking and focus on the matters that impact reliability the most. This RSAW has reverted to the historical looking compliance review. On every requirement, there are multiple statements that evidence will be requested for each calendar year since the last audit and that the compliance assessment approach will evaluate every year since the last compliance audit. For a TO or GO, this would represent six to seven years of evidence and review that would provide no reliability benefit. This RSAW needs to be revamped to be consistent with RAI principles.</p> <p>Response: The drafting team has provided your comments to NERC Compliance who develops the RSAW.</p> <p>(3) Thank you for the opportunity to comment.</p>
Manitoba Hydro	<p>1) In R1, please clarify what you mean by “Stability constrained”, does it mean the constraint for angular stability only or does it include other stability concerns such as transient voltage violations?</p> <p>Response: The drafting team added “angular” to “stability constraint” to clarify the intent in Requirement R1, both Criterion 1 and 2. Change made.</p> <p>2) Also in R1, does “Line-out conditions” mean “N-1” condition?</p> <p>Response: The phrase “line-out conditions” has been removed. Elements should be identified based on the Requirement R1 criterion regardless of the outage conditions that may be necessary to trigger enforcement of the System Operating Limit (SOL) or arming of the Special Protection System (SPS). The Guidelines and Technical Basis have been supplemented to provide additional information. (Note: The use of SPS has been replaced with Remedial Action Scheme (RAS) for consistency with a current project to revise the definition of “Special Protection System”). Change made.</p> <p>3) What definition of an island is used in the standard?</p> <p>Response: The drafting team modified Requirement R1, Criterion 3 to include island boundaries due to angular instability within an underfrequency load shedding (UFLS) assessment. Also, the Generator Owner was moved from Requirement R2 to</p>

Organization	Question 10 Comment
	<p>the new Requirement R3 in order to remove the “islanding” criteria for Generator Owners. Change made.</p> <p>4) In R1 through R4, why is long-term planning included in the time horizon? The standard is not clear that an assessment of the 10-year planning horizon is expected. It seems the assessment is more based on the current system or at most plans proposed to be implemented in the next year, which makes this applicable to Operations Planning only. The Table of compliance elements discussing notification deadlines of 30-90 days is more applicable to an Operations Planning time horizon. If we see an issue in 2020, due to a new proposed Facility, why do we have to notify anyone within 30 days today in order to be compliant with the standard? We have time to investigate alternatives, new settings etc. If the problem still exists in the operations horizon, this standard is applicable.</p> <p>Response: For Requirement R1, the drafting team eliminated the “Time-Horizon: Operation Planning” because it occurs on an annual basis and violating the Requirement beyond a year without mitigation would have little impact. Under the definition, “Time Horizon: Long-term Planning” is a planning horizon of one year or longer.<sup>12</sup></p> <p>Requirement R2 (and the new R3) eliminated the “Time Horizon: Operation Planning” and kept “Time Horizon: Long-term Planning” because the information would be used by the PC in its annual assessments and violating the Requirement beyond a year and would have little impact to the Planning Coordinator’s assessments. The drafting team eliminated “Time Horizon: Long-term Planning” and kept “Time Horizons: Operations Planning” for Requirement R4 (previously R3) and the new Requirement R5 because the associated timeframes comport with a “Time Horizon: Operations Planning.” For Requirement R6 (previously R4), the drafting team eliminated the “Time Horizon: Operation Planning” because the failure to implement the CAP beyond a year without mitigation would have little impact when the length of CAPs that are generally implemented over several years. Change made.</p>
<p>Northeast Utilities (Bill Temple)</p>	<p>1. The annual frequency requirements listed in R1 &amp; R2 are not necessary and that a less frequent (ie: Every 5 years) would be more appropriate.</p> <p>Response: The drafting team increased the Implementation Plan to three years to provide for the initial influx of identified Elements under Requirement R1. The evaluation of relays under Requirement R4 (previously R3) is to be performed “within 12 full calendar months of receiving notification of an Element ... where the evaluation has not been performed in the last</p>

<sup>12</sup> [http://www.nerc.com/pa/Stand/Resources/Documents/Time\\_Horizons.pdf](http://www.nerc.com/pa/Stand/Resources/Documents/Time_Horizons.pdf)

Organization	Question 10 Comment
	<p>three calendar years.” Change made.</p> <p>2. Please provide more examples to help further illustrate the criteria in listed in R1. Response: The drafting team provided additional detail in the Guidelines and Technical Basis. Change made.</p> <p>3. Please differentiate between Stable and Unstable power swings. Response: The drafting team provided the general definitions in the Guidelines and Technical Basis. Change made.</p>
<p>Northeast Utilities, supplemental comment (Mark Kenny)</p>	<p>Northeast Utilities is voting Negative based on the following concerns:</p> <ul style="list-style-type: none"> <li>• Potential Costs associated with relay upgrades</li> </ul> <p>Response: The drafting team recognizes that cost is a consideration; however, this standard’s approach narrowly focuses the reliability objectives to a select set of BES Elements (i.e., Requirement R1) to address the power swing concern where it is expected to be of greatest risk. This minimizes the cost to entities and compliance burden by not requiring the standard to be applicable to the entire BES. No change made.</p> <ul style="list-style-type: none"> <li>• Lack of clarity in some of the criteria in requirements <ul style="list-style-type: none"> <li>o What is considered a credible event?</li> </ul> </li> </ul> <p>Response: The term “credible” has been removed from the standard. The drafting team clarified Requirement R1, Criterion 3 by framing the criterion in the present tense to refer to current assessment(s). The term “credible” was removed from the previous Requirement R2 (and new R3) because the required performance refers to only current actual events. Change made.</p> <ul style="list-style-type: none"> <li>o Should Planning assessment be used to capture relay tripping or just stable power swing or both stable and unstable power swing?</li> </ul> <p>Response: Requirement R1, Criterion 4 requires identification of any Element that was observed as tripping in the most recent Planning Assessment pursuant to TPL-001-4, R4, Part 4.3.1.3 – “Tripping of Transmission lines and transformers where transient swings cause Protection System operation based on generic or actual relay models” which becomes effective January 1, 2015 (U.S.). Other clarifying changes were made to Requirement R1, Criterion 4.</p>



Organization	Question 10 Comment
	<ul style="list-style-type: none"> <li>o Is the purpose of the standard is to ensure blocking for a stable power swing and dependable tripping for unstable power swing?</li> </ul> <p>Response: The Purpose statement was modified to note that the purpose is to ensure that relays “are expected to not trip.” This may include the use of power swing blocking.</p> <ul style="list-style-type: none"> <li>• Annual analysis is to frequent</li> </ul> <p>Response: Requirements R1-R3, R5, and R6 all become effective following approval and require evaluation under the time period allotted in Requirement R4 (previously R3) for any identified Elements. The Planning Coordinator is to become compliant with the initial identification of Elements in Requirement R1 during the calendar year after 12 calendar months of approval and perform Requirement R1 each calendar year thereafter.</p> <p>Requirement R4 (previously R3) will become effective 36 calendar months following approval of the standard. During the implementation of the standard, notifications (i.e., from R1-R3) are likely to occur prior to Requirement R4 becoming effective. Where notification under R1 or identification under Requirement R2 or R3 occurs prior to the Effective Date of Requirement R4, the 12 month time period in Requirement R4 will begin from the Effective Date of Requirement R4. Thereafter, entities will follow the 12 month time period in R4. The intention of the additional time for R4 to become effective is to handle the initial influx of notifications and identifications. Change made.</p> <ul style="list-style-type: none"> <li>• Requiring an entity to provide data on an Element that had tripped since 2003 is inconsistent with other NERC Standards related to disturbance monitoring or misoperations, where data does not need to be retained for more than 12 months.</li> </ul> <p>Response: The “January 1, 2003” date has been removed from the standard. Requirement R2 (and new R3) are based on actual Disturbances that occur after the Effective Date of the standard. Events that occur will be reported to the Planning Coordinator in order to maintain the Element as an “identified Element.” Change made.</p>
<p>American Electric Power</p>	<p>AEP supports the proposed standard’s scope and overall direction, but has chosen to vote negative based on the various concerns expressed in our response. AEP envisions voting in the affirmative once sufficient concerns have been addressed in future drafts.</p> <p>R2 should be revised to be forward-looking only. Generator Owners and Transmission Owners were not required in the past</p>

Organization	Question 10 Comment
	<p>to keep comprehensive records of these events and cannot be expected to know all applicable Elements as implied by the standard. If after the initial standard implementation period, an Entity identifies an applicable Element based on a Disturbance occurring between 1/1/2003 and the standard effective date, the Entity could be found non-compliant with R2 and R3. If the drafting team feels it is absolutely necessary to go back to 2003, the standard should be revised to allow an Entity to remain fully compliant with R2 and R3 at any time an Element is identified based on a Disturbance occurring between 1/1/2003 and the effective date of the standard. This could be accomplished by adding wording to bring newly identified Elements into scope of R2 and R3 during the first full calendar year after they are identified. The R2 criterion assumes that registered entities have had a process in place to flag events due to power swings and retain information related to them. We do not believe that industry should be required to identify and provide information on events that have occurred in the past. There has been no established standard requirement to capture this information, so there is no way to reliably conclude that all events caused by power swings have been identified. In the event such historical information *is* required, the standard should explicitly state that such information is needed only once rather than once every calendar year.</p> <p>Response: The "January 1, 2003" date has been removed from the standard. Requirement R2 (and new R3) are based on actual Disturbances that occur after the Effective Date of the standard. Events that occur will be reported to the Planning Coordinator in order to maintain the Element as an "identified Element." Change made.</p> <p>The standard should require the Transmission Owner to make the system impedance available to the Generator Owner annually or within 30 days of a written request. The Generator Owner would not normally have this information, but will need it in order to meet their obligations under R3.</p> <p>Response: The standard does not preclude the Planning Coordinator from providing information to the Generator Owner or Transmission Owner about a particular Element (e.g., known stability issues, power swings, or apparent impedance characteristics). The drafting team has not included a Requirement for the exchange of information; that is being managed by entities outside of Reliability Standard requirements.</p> <p>It is not clear why R3 will require the TO/GO's Elements to be studied annually. A study's result should remain valid until either the relay setting changes or the impedance changes significantly. The standard should be revised to only require a study be repeated if the relay setting is changed or if the generator, GSU or system impedances change by 10% or more.</p> <p>Response: The drafting team increased the Implementation Plan to three years to provide for the initial influx of identified</p>

Organization	Question 10 Comment
	<p>Elements under Requirement R1. The evaluation of relays under Requirement R4 (previously R3) is to be performed “within 12 full calendar months of receiving notification of an Element ... where the evaluation has not been performed in the last three calendar years.” Change made.</p> <p>The standard should not require the study of voltage controlled/restrained overcurrent relays or loss of field relays. In stable power swings, the voltage should remain above the threshold that allows these voltage controlled/restrained overcurrent relays to operate. Failure to set the relay appropriately should be reported and corrected under the requirements of PRC-004. Loss of field relays are installed as part of the generator protection and should be permitted to trip when necessary to protect the generator, regardless of whether the power swing is stable or unstable.</p> <p>Response: The drafting team provided an exclusion for voltage controlled/restrained overcurrent relays in PRC-026-1 – Attachment A; however, the standard remains applicable to loss of field relays. This draft of the proposed standard is now consistent with the approach generally employed by industry for ensuring loss of field relays do not trip in response to a stable power swing. Change made.</p>
Lincoln Electric System	<p>Although appreciative of the drafting team’s efforts in developing PRC-026-1, LES questions whether the development of a Reliability Standard is necessary for addressing relay performance during stable power swings. Further consideration should instead be given to the recommendations of the System Protection and Control Subcommittee which noted that “a NERC Reliability Standard to address relay performance during stable power swings is not needed, and could result in unintended adverse impacts to Bulk Power System reliability”. In lieu of the standards development process, LES suggests communicating to FERC an alternative to a Reliability Standard such as an industry guidance or reference document.</p> <p>Response: Please see the section at the beginning of this document called, “NERC Discussion on Proceeding(s) and Directives Regarding: Stable Power Swings” for a complete background. The SDT understands that NERC staff re-engaged FERC staff following the completion of the PSRPS Report and that the Commission still desired NERC to pursue its work to meet the directive. However, FERC staff was open to an approach designed by NERC. NERC staff has informally received positive feedback on the approach to address the regulatory directive. The directive itself was challenged by commenters prior to the issuance of Order No. 733 and was already the subject of multiple rehearing requests in the Order No. 733-A and Order No. 733-B proceedings. Similar arguments to the conclusions of the NERC System Protection and Control Subcommittee were advanced in these FERC proceedings.</p>

Organization	Question 10 Comment
<p>Arizona Public Service Co.</p>	<p>APS recommends that the drafting team require an initial identification and notification of each Element that meets the criteria described R1. A review of the assessment should not be required yearly if there are no additions to the entity system meeting the criteria. It would be more practical to require a comprehensive review every five years.</p> <p>Response: The drafting team increased the Implementation Plan to three years to provide for the initial influx of identified Elements under Requirement R1. The evaluation of relays under Requirement R4 (previously R3) is to be performed “within 12 full calendar months of receiving notification of an Element ... where the evaluation has not been performed in the last three calendar years.” Change made.</p> <p>In addition, the standard should require that if Elements are added to the entity system that meet the criteria in R1, the applicable entity should provide updates within 90 days of the commissioning of a new Element.</p> <p>Response: The drafting team contends that Requirement R1 does not preclude the Planning Coordinator from providing notice of an identified Element more frequently. No change made.</p> <p>APS believes that the current draft requirement is administrative in nature and represents a reporting burden.</p> <p>Response: The proposed standard is consistent with the PSRPS Report which recommends a focused approach to identifying Elements that are most susceptible to power swings. No change made.</p>
<p>New York Power Authority</p>	<p>As previously answered, the referenced 61-page PSRPS technical document, from which much of this Standard’s wording is copied from, specifically recommends against this standard.</p> <p>Again, as stated in Pages 5, 20, and 24: “Based on its review of historical events, consideration of the trade-offs between dependability and security, and recognizing the indirect benefits of implementing the transmission relay loadability standard (PRC-023), the SPCS concludes that a NERC reliability Standard to address relay performance during stable power swings is not needed, and could result in unintended adverse impacts to Bulk-Power System reliability.”</p> <p>Response: Please see the section at the beginning of this document called, “NERC Discussion on Proceeding(s) and Directives Regarding: Stable Power Swings” for a complete background. The SDT understands that NERC staff re-engaged FERC staff following the completion of the PSRPS Report and that the Commission still desired NERC to pursue its work to meet the directive. However, FERC staff was open to an approach designed by NERC. NERC staff has informally received positive</p>

Organization	Question 10 Comment
	<p>feedback on the approach to address the regulatory directive. The directive itself was challenged by commenters prior to the issuance of Order No. 733 and was already the subject of multiple rehearing requests in the Order No. 733-A and Order No. 733-B proceedings. Similar arguments to the conclusions of the NERC System Protection and Control Subcommittee were advanced in these FERC proceedings.</p>
<p>Puget Sound Energy</p>	<p>As stated in the document entitled "Protection System Response to Power Swings" by PSRPS, a review of historical system disturbances determined that operation of transmission line protection systems during stable power swings was not causal or contributory to any of the disturbances reviewed. The final conclusion of PSRPS was that a NERC Reliability Standard is not needed to address relay performance due to stable power swings and could result in unintended adverse impacts to Bulk Power System reliability. In light of this conclusion, as well as the comments contained in this form, we have voted 'no' on this standard.</p> <p>Response: Please see the section at the beginning of this document called, "NERC Discussion on Proceeding(s) and Directives Regarding: Stable Power Swings" for a complete background. The SDT understands that NERC staff re-engaged FERC staff following the completion of the PSRPS Report and that the Commission still desired NERC to pursue its work to meet the directive. However, FERC staff was open to an approach designed by NERC. NERC staff has informally received positive feedback on the approach to address the regulatory directive. The directive itself was challenged by commenters prior to the issuance of Order No. 733 and was already the subject of multiple rehearing requests in the Order No. 733-A and Order No. 733-B proceedings. Similar arguments to the conclusions of the NERC System Protection and Control Subcommittee were advanced in these FERC proceedings.</p> <p>Response: Minor clarification to the above comment. The NERC System Protection and Control Subcommittee (SPCS) authored the <i>Protection System Response to Power Swings, August 2013</i><sup>13</sup> (PSRPR Report) technical document. This drafting team took on the Protection System Response to Power Swings Standard Drafting Team (PSRPS SDT) designation. The drafting team has drafted the standard consistent with the approach provided by the PSRPS Report.</p>

<sup>13</sup> NERC System Protection and Control Subcommittee, *Protection System Response to Power Swings*, August 2013:  
[http://www.nerc.com/comm/PC/System%20Protection%20and%20Control%20Subcommittee%20SPCS%2020/SPCS%20Power%20Swing%20Report\\_Final\\_20131015.pdf](http://www.nerc.com/comm/PC/System%20Protection%20and%20Control%20Subcommittee%20SPCS%2020/SPCS%20Power%20Swing%20Report_Final_20131015.pdf)

Organization	Question 10 Comment
<p>American Transmission Company, LLC</p>	<p>ATC recommends the SDT consider the following changes to add clarity to the Standard:</p> <p>a. Applicability (Section 4.1.1 &amp; 4.1.4), Requirement R2 - Replace “load responsive” protective relays with “impedance based” protective relays.</p> <p>Response: The drafting team did not add the proposed suggestion, but did add a clarification that standard is applicable to load-responsive protective relays (including overcurrent) which could trip instantaneously or with a time delay of less than 15 cycles. Change made.</p> <p>b. Requirement R1 - ATC questions the necessity of performing the identification and notification in any particular month. Why does the requirement stipulate “within the first month of each calendar year”? ATC believes that it should be sufficient to use wording like, “at least once each calendar year”.</p> <p>Response: The drafting team adjusted the time periods in the proposed Requirements and Implementation Plan to account for varying activities. Change made.</p> <p>c. Requirements R.1.1, R1.2 - What is meant by “stability constraints” (e.g. steady state voltage, transient voltage, steady state angle, transient angle)? ATC recommends that the SDT use descriptive adjectives before “stability constraint” to clarify which one, or ones, are intended.</p> <p>Response: The drafting team added “angular” to “stability constraint” to clarify the intent in Requirement R1, both Criterion 1 and 2. Change made.</p> <p>d. Requirements R1.3, R1.4 - What is meant by “Disturbances” (e.g. Category B, Category C, P1-P7)? ATC recommends that the SDT use descriptive adjectives before “Disturbances” to clarify which one, or ones, are intended.</p> <p>Response: The drafting team revised Requirement R1, Criterion 4 by changing “Disturbance” to “simulated disturbance” to comport with the approved Reliability Standard TPL-001-4. The use of “Disturbance” in Requirements R2 (TO) and new R3 (GO) relates to an actual system Disturbance. Change made.</p> <p>e. Requirements R1.3, R2.1, R2.2 - What is meant by the term “credible” when discussing Disturbances (e.g. Disturbances associated with islands that were selected through R2 of PRC-006-1)? ATC suggests developing proposed alternate language like, “relevant”, which is easier to demonstrate simply with power flow analysis, rather than valid statistical analysis.</p>

Organization	Question 10 Comment
	<p>Response: The term “credible” has been removed from the standard. The drafting team clarified Requirement R1, Criterion 3 by framing the criterion in the present tense to refer to the current assessment(s). Islands caused by natural phenomena (i.e., Disturbances) are covered under Requirement R2. Change made.</p> <p>f. Requirement R1.4 - What is meant by “most recent Planning Assessment”? (e.g. TPL-002/TPL-003 annual assessment, FAC-002-1 interconnection assessment) ? ATC recommends to specify which type, or types, are intended.</p> <p>Response: The drafting team asserts that the most recent Planning Assessment provides a concrete reference to the information used in identifying BES Elements. Since the Planning Assessments (i.e., TPL-001-4) are performed annually, any other description would create confusion as to whether an entity should use past information or information revealed during preparation of a Planning Assessment. No change made.</p> <p>g. Requirement R2, Criteria 1 and 2 - ATC has concerns about requiring entities to refer to data on power swings and forming an island back to 1 Jan 2003. ATC recommends additional text in the Criteria such as “if available prior to the effective date” immediately after “since January 1, 2003”. Retaining this data prior 1 Jan 2003 was not required as implied by the proposed Standard. Another approach for SDT consideration would be to require retention of data from the effective date of the Standard.</p> <p>Response: The “January 1, 2003” date has been removed from the standard. Requirement R2 (and new R3) are based on actual Disturbances that occur after the Effective Date of the standard. Change made.</p> <p>h. Requirements R2.1, R2.2 - ATC questions the inclusion of the statement “since January 1, 2003”. ATC believes that a specific historical time frame would be more appropriate, such as “in the past 10 years”. Referring to “since January 1, 2003” makes an ever expanding historical time frame, which at some point, should no longer be relevant.</p> <p>Response: The “January 1, 2003” date has been removed from the standard. Requirement R2 (and new R3) are based on actual Disturbances that occur after the Effective Date of the standard. Change made.</p> <p>i. R3 - The “Criterion” text only applies to bullet 1 and 3 only, but due to the indentation appears to be a sub element of bullet 4. Therefore, ATC suggests that the “Criterion” be moved more to the left move to avoid the appearance of only applying to bullet 4.</p> <p>Response: The drafting team has revised Requirement R4 (previously R3) and moved the criteria to PRC-026-1 – Attachment B</p>

Organization	Question 10 Comment
	to increase the understandability of the Requirement. Change made.
Bonneville Power Administration	<p>BPA feels the Glossary definition of Disturbance lacks sufficient clarity as it relates to this and other existing Standards. BPA also requests a descriptive title be used for the Criterion (e.g. Criterion for Swing Protection Analysis).</p> <p>Response: The drafting team revised Requirement R1, Criterion 4 by changing “Disturbance” to “simulated disturbance” to comport with the approved Reliability Standard TPL-001-4. The use of “Disturbance” in Requirements R2 (TO) and new R3 (GO) relates to an actual system Disturbance. Change made.</p> <p>Response: The drafting team has revised Requirement R4 (previously R3) and moved the criteria to PRC-026-1 – Attachment B to increase the understandability of the Requirement. Change made.</p>
Dominion	<p>Dominion suggests that Associated Documents (at least those where there are no copyright concerns) be included in the standard as attachments or appendices as we are concerned that cited URLs will change over time.</p> <p>Response: Thank you for your comment.</p> <p>Requirement R2 Criteria 1 and 2 require review of Disturbances since January 1, 2003. While Dominion recognizes the desire to consider Disturbances since January 1, 2003 in order to capture the August 14, 2003 Blackout, it is important to note that NERC Reliability Standards were not mandatory at that point and data may or may not be available. Dominion recommends changing the criteria dates to June 18, 2007 to be consistent with the establishment of mandatory and enforceable Reliability Standards.</p> <p>Response: The “January 1, 2003” date has been removed from the standard. Requirement R2 (and new R3) are based on actual Disturbances that occur after the Effective Date of the standard. Change made.</p>
Duke Energy	<p>Duke Energy would like to reiterate that we do not believe adequate technical justification has been identified for this project to become a standard. Based on the SPCS recommendation, the SDT and NERC should consider moving this project to a Guideline document until such time as a standard is warranted.</p> <p>Response: Please see the section at the beginning of this document called, “NERC Discussion on Proceeding(s) and Directives Regarding: Stable Power Swings” for a complete background. The SDT understands that NERC staff re-engaged FERC staff</p>



Organization	Question 10 Comment
	<p>following the completion of the PSRPS Report and that the Commission still desired NERC to pursue its work to meet the directive. However, FERC staff was open to an approach designed by NERC. NERC staff has informally received positive feedback on the approach to address the regulatory directive. The directive itself was challenged by commenters prior to the issuance of Order No. 733 and was already the subject of multiple rehearing requests in the Order No. 733-A and Order No. 733-B proceedings. Similar arguments to the conclusions of the NERC System Protection and Control Subcommittee were advanced in these FERC proceedings.</p>
<p>Electric Reliability Council of Texas, Inc.</p>	<p>ERCOT agrees with the NERC System Protection and Control Subcommittee August 2013 report titled Protection System Response to Power Swings which states: “Based on its review of historical events, consideration of the trade-offs between dependability and security, and recognizing the indirect benefits of implementing the transmission relay loadability standard (PRC-023), the SPCS concludes that a NERC Reliability Standard to address relay performance during stable power swings is not needed, and could result in unintended adverse impacts to Bulk-Power System reliability.” Accordingly, ERCOT recommends that the standard not move forward.</p> <p>Response: Please see the section at the beginning of this document called, “NERC Discussion on Proceeding(s) and Directives Regarding: Stable Power Swings” for a complete background. The SDT understands that NERC staff re-engaged FERC staff following the completion of the PSRPS Report and that the Commission still desired NERC to pursue its work to meet the directive. However, FERC staff was open to an approach designed by NERC. NERC staff has informally received positive feedback on the approach to address the regulatory directive. The directive itself was challenged by commenters prior to the issuance of Order No. 733 and was already the subject of multiple rehearing requests in the Order No. 733-A and Order No. 733-B proceedings. Similar arguments to the conclusions of the NERC System Protection and Control Subcommittee were advanced in these FERC proceedings.</p> <p>If the standard does move forward ERCOT recommends that requirements R1, R2, and R3 be changed from an annual requirement to once every 60 months in order to minimize unintended adverse impacts to Bulk-Power System reliability.</p> <p>Response: The drafting team increased the Implementation Plan to three years to provide for the initial influx of identified Elements under Requirement R1. The evaluation of relays under Requirement R4 (previously R3) is to be performed “within 12 full calendar months of receiving notification of an Element ... where the evaluation has not been performed in the last three calendar years.” Change made.</p>

Organization	Question 10 Comment
<p>Ingleside Cogeneration LP</p>	<p>ICLP believes that the findings by NERC’s System Protection and Control Subcommittee (SPCS) compellingly demonstrate that the initial findings from the 2003 Northeastern blackout were flawed. There is no doubt some load responsive relays did trip during the event when unusual, but non-threatening transients manifested themselves as a result of a downstream Fault. However, the SPCS found that in every case, a subsequent unstable power swing followed within seconds - and the relay would have tripped anyways. Furthermore, planning simulations confirmed that had the stable power swing in question had taken place under N-1 and N-2 contingencies - the norm to which the electric system is designed - those relays would not have reacted.</p> <p>Even more concerning, the report goes on to say that “over-emphasizing secure operation for stable powers swings could be detrimental to Bulk-Power System reliability” (see page 19). This means that FERC Order 733, which relies heavily on the 2003 investigative task force recommendations, may actually increase the threat of wide-area instability or Cascading.</p> <p>ICLP does not question FERC’s authority to order the development of a Reliability Standard - and we agree the subject matter is ultra-complex. Nevertheless, FERC should be operating to the best information available, which may have changed over time. There are far too many other pressing priorities for Registered Entities, CEAs, and even the Commission to expend this much effort on one that has little or even negative benefit.</p> <p>At the very least, we would like NERC or the SPCS to request a Technical Conference on the subject. Other such conferences in the past seem to have resulted in effective, yet reasonable, approaches to similarly complex issues.</p> <p>Response: Please see the section at the beginning of this document called, “NERC Discussion on Proceeding(s) and Directives Regarding: Stable Power Swings” for a complete background. The SDT understands that NERC staff re-engaged FERC staff following the completion of the PSRPS Report and that the Commission still desired NERC to pursue its work to meet the directive. However, FERC staff was open to an approach designed by NERC. NERC staff has informally received positive feedback on the approach to address the regulatory directive. The directive itself was challenged by commenters prior to the issuance of Order No. 733 and was already the subject of multiple rehearing requests in the Order No. 733-A and Order No. 733-B proceedings. Similar arguments to the conclusions of the NERC System Protection and Control Subcommittee were advanced in these FERC proceedings.</p>
<p>Los Angeles</p>	<p>LADWP is voting “Negative” on PRC-026-1 for the reason that the reference document entitled “Protection System Response</p>

Organization	Question 10 Comment
<p>Department of Water and Power</p>	<p>to Power Swings” (the PSRPS document) used to justify the standard does not support the need for a reliability standard.</p> <p>Response: Please see the section at the beginning of this document called, “NERC Discussion on Proceeding(s) and Directives Regarding: Stable Power Swings” for a complete background. The SDT understands that NERC staff re-engaged FERC staff following the completion of the PSRPS Report and that the Commission still desired NERC to pursue its work to meet the directive. However, FERC staff was open to an approach designed by NERC. NERC staff has informally received positive feedback on the approach to address the regulatory directive. The directive itself was challenged by commenters prior to the issuance of Order No. 733 and was already the subject of multiple rehearing requests in the Order No. 733-A and Order No. 733-B proceedings. Similar arguments to the conclusions of the NERC System Protection and Control Subcommittee were advanced in these FERC proceedings.</p>
<p>MidAmerican Energy Company</p>	<p>MidAmerican has concerns about the actual reliability benefit the proposed PRC-026 standards would provide versus the incremental compliance analysis work. There is also the potential for scope creep and the industry needs to focus on appropriate risks. The criteria specified under R1 could be broad. Criterion 4 seems susceptible to significant scope creep stating, “An Element identified in the more recent Planning Assessment where relay tripping occurred for a power swing during a disturbance.” Planning Assessments are performed regularly in the TPL standards.</p> <p>Response: The drafting team asserts that if the Planning Assessment (i.e., TPL-001-4) shows tripping for a power swing, the Element would be identified under the Requirement. Additional discussion is provided in the Guidelines and Technical Basis regarding Criterion 4 under the heading “Requirement R1.” No change made.</p> <p>The new TPL-001-4 planning standard and R3.1.1 requires the simulated “removal of all elements that the Protection System and other automatic controls are expected to disconnect for each Contingency without operator intervention”. At a minimum, this will require generic protection models for each BES line, generator, and transformer. If the Planning assessment shows a protection model trip, will that element require a PRC-026 analysis?</p> <p>Response: The drafting team would not expect an entity to model tripping under TPL-001-4, R3 (R3.3.1 as referenced by the quote). Tripping of an Element observed in the stability section under Requirement R4, 4.3.1.3 would be an Element identified under PRC-026-1, Requirement R1, Criteria 4 and analyzed by the Generator Owner or Transmission Owner under the proposed Requirement R4 (previously R3). No change made.</p>

Organization	Question 10 Comment
	<p>Many entities are performing stability studies for existing TOP standards on a short-term to nearly daily basis to verify that entities are not entering and “unknown state”. While such studies aren’t a traditional “Planning Assessments”, could short-term TOP related dynamic analyses that show potential tripping (such as exceeding a protection setting limit) be forced to prove tripping wasn't due to stable power swings in PRC-026?</p> <p>Response: The drafting team asserts “operations assessments” are not considered within the scope of the proposed standard. The standard addresses the risk for specific Elements and conditions revealed in operations assessments and could be communicated to the Planning Coordinator for evaluation and possible identification under PRC-026-1, Requirement R1, Criterion 4. No change made.</p> <p>Will the criteria in R1 inappropriately identify suggested islands required by PRC-006? The NERC PRC-006 UFLS standards require entities to identify and simulate islands. Will PRC-026 inappropriately identify PRC-006 islands (which may not have a real UFLS event as a basis) because PRC-006 required an island be developed and a simulation be performed by a powerflow stability simulation which considers angular stability? Criterion 3 mentions both island boundaries and angular stability. There is a qualifier of a credible event. But entities will construct reasonable events for PRC-006. Are reasonable and credible the same?</p> <p>Response: The term “credible” has been removed from the standard. The drafting team clarified Requirement R1, Criterion 3 by framing the criterion in the present tense to refer to the current assessment(s). Islands caused by natural phenomena (i.e., Disturbances) are covered under Requirement R2. Change made.</p>
DTE Electric	No comment
FirstEnergy Corp.	None
Oncor Electric Delivery LLC	<p>R1 criteria 4 states to identify the following element: “An Element identified in the most recent Planning Assessment where relay tripping occurred for a power swing during a Disturbance.” In the statement above it is not clear whether the disturbance is actual or simulated.</p> <p>Response: The drafting team revised Requirement R1, Criterion 4 by changing “Disturbance” to “simulated disturbance” to</p>

Organization	Question 10 Comment
	<p>comport with the approved Reliability Standard TPL-001-4. The use of “Disturbance” in Requirements R2 (TO) and new R3 (GO) relates to an actual system Disturbance. Change made.</p> <p>R4 should state Each Generator Owner and Transmission Owner shall implement each CAP developed pursuant to Requirement R3 if option 3 or option 4 are chosen, and update each CAP if actions or timetables change, until all actions are complete. There should be no CAP required if R3 option 2 is chosen and the application of power swing blocking must be applied to specific relay locations.</p> <p>Response: The drafting team has modified the Requirements to be clearer that a CAP is required when the entity must develop a Corrective Action Plan (CAP) to modify a Protection System to meet the PRC-026-1 – Attachment B. Change made.</p> <p>Oncor agrees with the recommendation of the NERC PC (SCPS) and recommends if this has not been reviewed by NERC RISC, this may be an opportunity for the NERC Standard Committee (SC) to bring back to RISC for discussion in conjunction with the PSRPS technical document.</p> <p>Response: Please see the section at the beginning of this document called, “NERC Discussion on Proceeding(s) and Directives Regarding: Stable Power Swings” for a complete background. The SDT understands that NERC staff re-engaged FERC staff following the completion of the PSRPS Report and that the Commission still desired NERC to pursue its work to meet the directive. However, FERC staff was open to an approach designed by NERC. NERC staff has informally received positive feedback on the approach to address the regulatory directive. The directive itself was challenged by commenters prior to the issuance of Order No. 733 and was already the subject of multiple rehearing requests in the Order No. 733-A and Order No. 733-B proceedings. Similar arguments to the conclusions of the NERC System Protection and Control Subcommittee were advanced in these FERC proceedings.</p>
<p>CHPD - Public Utility District No. 1 of Chelan County</p>	<p>R1.1 - There should be a clarification or definition of a line-out condition. The meaning and intent of this note is not clear.</p> <p>Response: The phrase “line-out conditions” has been removed. Elements should be identified based on the Requirement R1 criterion regardless of the outage conditions that may be necessary to trigger enforcement of the System Operating Limit (SOL) or arming of the Special Protection System (SPS). The Guidelines and Technical Basis have been supplemented to provide additional information. (Note: The use of SPS has been replaced with Remedial Action Scheme (RAS) for consistency with a current project to revise the definition of “Special Protection System”). Change made.</p>

Organization	Question 10 Comment
Liberty Electric Power	<p>R2 requires Generator Operators to possess evidence prior to the enforcement date of the Standards, and prior to the passage of the Energy Act of 2005. No standard should be written which requires an entity to possess, analyze, or have knowledge of an event prior to the effective date of the standard. The beginning date of analysis should be the first full calander year after the FERC approval date of the standard.</p> <p>Response: The term “credible” has been removed from the standard. The drafting team clarified Requirement R1, Criterion 3 by framing the criterion in the present tense to refer to the current assessment(s). Islands caused by natural phenomena (i.e., Disturbances) are covered under Requirement R2. Change made.</p>
Bureau of Reclamation	<p>Reclamation suggests that R2 be rephrased to only require analysis of data from the previous year. As written, R2 would require Transmission Owners and Generator Owners to re-analyze data going back to 2003 each year. Reclamation believes that the costs of re-analyzing this data would outweigh the benefits. Reclamation believes that NERC should develop a data request to develop a robust initial data set covering January 2003 to present.</p> <p>Response: The “January 1, 2003” date has been removed from the standard. Requirement R2 (and new R3) are based on actual Disturbances that occur after the Effective Date of the standard. Events that occur will be reported to the Planning Coordinator in order to maintain the Element as an “identified Element.” Change made.</p>
ReliabilityFirst	<p>ReliabilityFirst offers the following comments for consideration.</p> <ol style="list-style-type: none"> <li>Requirement R1 - To be consistent with other NERC Reliability Standards, ReliabilityFirst suggests reclassifying the “criteria” as “sub-parts” of the requirement.</li> </ol> <p>Response: The drafting team has revised Requirement R4 (previously R3) and moved the criteria to PRC-026-1 – Attachment B to increase the understandability of the Requirement. Change made.</p> <ol style="list-style-type: none"> <li>Requirement R2 - R2 requires GOs and TOs to evaluate Disturbances “since January 1, 2003”. It appears that the intent of this requirement is to include Elements where actual system events caused a trip due to a known power swing and, by including the 2003 date, ensured that events associated with the 2003 Blackout were included. However, this may imply that events prior to 2003 need not be considered, especially in areas other than the Northeast where the blackout occurred. If an Element had a known trip for power swings associated with a Disturbance, they should be included. Therefore, ReliabilityFirst</li> </ol>

Organization	Question 10 Comment
	<p>recommends the flowing for consideration for the two criteria:"</p> <ol style="list-style-type: none"> <li>1. An Element that has tripped since January 1, 2003 [(or known historical Element that tripped prior to January 1, 2003)], due to a power swing during an actual system Disturbance where the Disturbance(s) that caused the trip due to a power swing continues to be credible.</li> <li>2. An Element that has formed the boundary of an island since January 1, 2003 [(or known historical Element that formed the boundary of an island prior to January 1, 2003)], during an actual system Disturbance where the Disturbance(s) that caused the islanding condition continues to be credible."</li> </ol> <p>Response: The "January 1, 2003" date has been removed from the standard. Requirement R2 (and new R3) are based on actual Disturbances that occur after the Effective Date of the standard. Events that occur will be reported to the Planning Coordinator in order to maintain the Element as an "identified Element." Change made.</p> <p>3. Requirement R3 - ReliabilityFirst requests clarification on how the Criterion in Requirement R3 fits into the requirement. Is this criterion part of the requirement or is it additional information? If it is the later, ReliabilityFirst believes this guidance is already covered in the "Guidelines and Technical Basis" section and should be removed from the requirements. NERC Reliability Requirements should address "what" is required and not "how" an entity will comply.</p> <p>Response: The drafting team has revised Requirement R4 (previously R3) and moved the criteria to PRC-026-1 – Attachment B to increase the understandability of the Requirement. Change made.</p>
Salt River Project	<p>Salt River Project is concerned that system protection should not be "de-tuned" at the expense of the protection provided the Bulk Electric System for the sake of reliability.</p> <p>Response: Please see the section at the beginning of this document called, "NERC Discussion on Proceeding(s) and Directives Regarding: Stable Power Swings" for a complete background. The SDT understands that NERC staff re-engaged FERC staff following the completion of the PSRPS Report and that the Commission still desired NERC to pursue its work to meet the directive. However, FERC staff was open to an approach designed by NERC. NERC staff has informally received positive feedback on the approach to address the regulatory directive. The directive itself was challenged by commenters prior to the issuance of Order No. 733 and was already the subject of multiple rehearing requests in the Order No. 733-A and Order No. 733-B proceedings. Similar arguments to the conclusions of the NERC System Protection and Control Subcommittee were</p>

Organization	Question 10 Comment
	advanced in these FERC proceedings.
Texas Reliability Entity	<p>Section 1.2 - Evidence Retention: Language as written appears to be unnecessarily complicated. Suggest changing to: "Functional Entities shall retain evidence demonstrating compliance since the last audit or for three calendar years, whichever is longer."</p> <p>Response: NERC staff has informed the drafting team that the language in the evidence retention section is pro-forma language used in each Reliability Standard. After reviewing the language and consulting with NERC staff, no change has been made. The drafting team encourages TRE to contact NERC standards staff to determine whether a change is necessary to its pro-forma language.</p>
BC Hydro	<p>Since the SPCS has concluded that no lines were tripped due to stable power swings, in any of the major disturbances, the FERC directive is flawed, and this regulation should not be implemented.</p> <p>Response: The drafting team acknowledges BC Hydro's position on the FERC directive. However, the validity of the directive was challenged at multiple stages of the FERC proceeding and despite the arguments made, FERC issued its directive and has since maintained its position that a standard is needed to meet the directive. The drafting team is charged with designing a standard to meet the Commission directive. The drafting team understands that NERC staff re-engaged FERC staff following the completion of the PSRPS Report and that the Commission still desired NERC to pursue its work to meet the directive, but they were open to an approach designed by NERC. The drafting team thanks you for your comment.</p>
Northeast Power Coordinating Council	<p>Suggest that Associated Documents (at least those where there are no copyright concerns) be included in the standard as attachments or appendices as we are concerned that cited URLs will change over time. The information in the Criteria and Criterion in the standard should not be in the requirements, but in the Rationale Boxes.</p> <p>Response: It is more appropriate to cite a specific work where applicable. The drafting team has provided sufficient citations of the work and URL links, if available.</p>
Tacoma Power	Tacoma Power supports the spirit of PSEG's response to Question 3. Furthermore, Tacoma Power has the following, additional comments related to the January 1, 2003, date.



Organization	Question 10 Comment
	<p>1) Not all Generator Owners and Transmission Owners may be required to retain records going back to January 1, 2003.  Response: The “January 1, 2003” date has been removed from the standard. Requirement R2 (and new R3) are based on actual Disturbances that occur after the Effective Date of the standard. Change made.</p> <p>2) Apart from including the 2003 Northeast Blackout, no other technical justification has been provided for why the January 1, 2003, date was selected. Alternatives might be to indicate specific disturbances for which documentation likely exists or to conduct a data request to collect better information so that Requirements R1 and R2 could be consolidated and then provide more refined and simpler criteria.  Response: The “January 1, 2003” date has been removed from the standard. Requirement R2 (and new R3) are based on actual Disturbances that occur after the Effective Date of the standard. Change made.</p> <p>Setting aside the previous comment, does Requirement R2 Criterion 2 add any value beyond that provided by Criterion 1? If so, the term ‘island’ may need to be better defined.  Response: The drafting team has provided additional discussion and example why Criterion 2 is providing additional value. Change made.</p> <p>What is the technical basis in Requirement R2 for identification to occur in January of each year?  Response: The Requirement R1 language about “January of each calendar” has been removed and replaced with “each calendar year.” Based on time period changes in other Requirements, the drafting team determined that an annual periodicity in Requirement R1 is more appropriate. Change made.</p>
Luminant Generation Company LLC	<p>The Attachments to the standard should include a listing of the specific load responsive relays that are included in the scope of the standard.  Response: The drafting team has provided PRC-026-1 – Attachment A to address which relays are included and excluded. Change made.</p>
MRO NERC Standards	<p>The NSRF recommends the SDT consider the following changes to add clarity to the Standard:  a. Applicability (Section 4.1.1 and 4.1.4), Requirement R2 - Replace “load responsive” protective relays with “impedance</p>

Organization	Question 10 Comment
Review Forum	<p>based” protective relays.</p> <p>Response: The drafting team did not add the proposed suggestion, but did add a clarification that standard is applicable to load-responsive protective relays (including overcurrent) which could trip instantaneously or with a time delay of less than 15 cycles. Change made.</p> <p>b. Requirement R1 - The NSRF questions the necessity of performing the identification and notification in any particular month. Why does the requirement stipulate “within the first month of each calendar year”? THE NSRF believes that it should be sufficient to use wording like, “at least once each calendar year”.</p> <p>Response: The Requirement R1 language about “January of each calendar” has been removed and replaced with “each calendar year.” Based on time period changes in other Requirements, the drafting team determined that an annual periodicity in Requirement R1 is more appropriate. Change made.</p> <p>c. Requirements R.1.1, R1.2 - What is meant by “stability constraints” (e.g. steady state voltage, transient voltage, steady state angle, transient angle)? The NSRF recommends that the SDT use descriptive adjectives before “stability constraint” to clarify which one, or ones, are intended.</p> <p>Response: The drafting team added “angular” to “stability constraint” to clarify the intent in Requirement R1, both Criterion 1 and 2. Change made.</p> <p>d. Requirements R1.3, R1.4 - What is meant by “Disturbances” (e.g. Category B, Category C, P1-P7)? THE NSRF recommends that the SDT use descriptive adjectives before “Disturbances” to clarify which one, or ones, are intended.</p> <p>Response: The drafting team revised Requirement R1, Criterion 4 by changing “Disturbance” to “simulated disturbance” to comport with the approved Reliability Standard TPL-001-4. The use of “Disturbance” in Requirements R2 (TO) and new R3 (GO) relates to an actual system Disturbance. Change made.</p> <p>e. Requirements R1.3, R2.1, R2.2 - What is meant by the term “credible” when discussing Disturbances (e.g. Disturbances associated with islands that were selected through R2 of PRC-006-1)? THE NSRF suggests developing proposed alternate language like, “relevant”, which is easier to demonstrate simply with power flow analysis, rather than valid statistical analysis.</p> <p>Response: The term “credible” has been removed from the standard. The drafting team clarified Requirement R1, Criterion 3 by framing the criterion in the present tense to refer to the current assessment(s). Islands caused by natural phenomena (i.e.,</p>

Organization	Question 10 Comment
	<p>Disturbances) are covered under Requirement R2. Change made.</p> <p>f. Requirement R1.4 - What is meant by “most recent Planning Assessment”? (e.g. TPL-002/TPL-003 annual assessment, FAC-002-1 interconnection assessment) ? THE NSRF recommends to specify which type, or types, are intended.</p> <p>Response: The drafting team asserts that the most recent Planning Assessment provides a concrete reference to the information used in identifying BES Elements. Since the Planning Assessments (i.e., TPL-001-4) are performed annually, any other description would create confusion as to whether an entity should use past information or information revealed during preparation of a Planning Assessment. No change made.</p> <p>g. Requirements R2.1, R2.2 - The NSRF questions the inclusion of the statement “since January 1, 2003”. THE NSRF believes that a specific historical time frame would be more appropriate, such as “in the past 10 years”. Referring to “since January 1, 2003” makes an ever expanding historical time frame, which at some point, should no longer be relevant.</p> <p>Response: The “January 1, 2003” date has been removed from the standard. Requirement R2 (and new R3) are based on actual Disturbances that occur after the Effective Date of the standard. Change made.</p> <p>h. R3 - The “Criterion” text only applies to bullet 1 and 3 only, but due to the indentation appears to be a sub element of bullet 4. Therefore, THE NSRF suggests that the “Criterion” be moved more to the left move to avoid the appearance of only applying to bullet 4.</p> <p>Response: The drafting team has revised Requirement R4 (previously R3) and moved the criteria to PRC-026-1 – Attachment B to increase the understandability of the Requirement. Change made.</p> <p>NSRF has concerns about not having data back to 1 Jan 2003. R2 needs to have “if available prior to the effective date “. The SDT is looking for data before the effective date of the proposed Standard. We believe the intention of having the data but we did not know that the required data was needed to be saved from 1 Jan 2003. From the effective date of this Standard is another approach in retaining the required data.</p> <p>Response: The “January 1, 2003” date has been removed from the standard. Requirement R2 (and new R3) are based on actual Disturbances that occur after the Effective Date of the standard. Change made.</p>
Idaho Power	The PSRPS report and the SPS report no need for this Standard, stating that "operation of transmission line protection systems

Organization	Question 10 Comment
Co.	<p>during stable power swings was not causal or contributory to any of these disturbances." This statement conflicts with the need for the Standard and causes added Compliance burden to entities without reason.</p> <p>Response: Please see the section at the beginning of this document called, "NERC Discussion on Proceeding(s) and Directives Regarding: Stable Power Swings" for a complete background. The SDT understands that NERC staff re-engaged FERC staff following the completion of the PSRPS Report and that the Commission still desired NERC to pursue its work to meet the directive. However, FERC staff was open to an approach designed by NERC. NERC staff has informally received positive feedback on the approach to address the regulatory directive. The directive itself was challenged by commenters prior to the issuance of Order No. 733 and was already the subject of multiple rehearing requests in the Order No. 733-A and Order No. 733-B proceedings. Similar arguments to the conclusions of the NERC System Protection and Control Subcommittee were advanced in these FERC proceedings.</p>
Exelon	<p>The SPCS white paper "Protection System Response to Power Swings" (August 2013), found, "Based on its review of historical events, consideration of the trade-offs between dependability and security, and recognizing the indirect benefits of implementing the transmission relay loadability standard (PRC-023), the System Protection and Control Subcommittee (SPCS) concludes that a NERC Reliability Standard to address relay performance during stable swings is not needed, and could result in unintended adverse impacts to Bulk-Power System reliability."</p> <p>Notwithstanding that recommendation, the white paper also outlined an approach for developing a power swing reliability standard in the event a standard is proposed to address the FERC Directive. We agree that the SDT has adhered to the SPCS's recommendations in the present draft, but we do not believe that the technical basis for the SPCS recommendation against creating a standard has been challenged and that there is sufficient justification for continuing with the effort to write a standard addressing this issue. To the best of our knowledge, our operating companies, ComEd, BGE and PECO, have never experienced a relay trip due to a power swing. We recognize and appreciate the Drafting team's work in responding to comments to the SAR suggesting that alternative means of meeting the Directive should be explored. As discussed by numerous stakeholders in the previous response to comments, we believe further work in this area should continue.</p> <p>Response: Please see the section at the beginning of this document called, "NERC Discussion on Proceeding(s) and Directives Regarding: Stable Power Swings" for a complete background. The SDT understands that NERC staff re-engaged FERC staff following the completion of the PSRPS Report and that the Commission still desired NERC to pursue its work to meet the</p>

Organization	Question 10 Comment
	<p>directive. However, FERC staff was open to an approach designed by NERC. NERC staff has informally received positive feedback on the approach to address the regulatory directive. The directive itself was challenged by commenters prior to the issuance of Order No. 733 and was already the subject of multiple rehearing requests in the Order No. 733-A and Order No. 733-B proceedings. Similar arguments to the conclusions of the NERC System Protection and Control Subcommittee were advanced in these FERC proceedings.</p>
<p>Seattle City Light</p>	<p>The Standard is very complicated and confusing. It appears to be a lot like FERC Order 754 effort that we recently went through, which required two or three rounds of submissions before industry was providing the information envisioned by the framers of the process.</p> <p>Proposed PRC-026 involves considerable new interaction between the Planning and Protection groups. The Application Guidelines, while somewhat helpful, need to include much more explicit examples. A flow chart, or something similar, is necessary to fully delineate the steps in the process. Much more guidance is definitely needed before the Standard can be implemented.</p> <p><i>Response: The drafting team has substantively revised the standard and Guidelines and Technical Basis to improve the understandability. Change made.</i></p> <p>This draft of the Standard represents a work in progress, at best. Before any such untried process be mandated as a Standard (if it is ultimately deemed necessary that a Standard is required) Seattle City Light recommends a non-mandatory trial period of at least two years, long enough to work the bugs out of the system and ensure that entities understand and are able to perform the activities as envisioned and required. Perhaps such a trail could be conducted as a NERC request for data under Section 1600 Rules of Procedure.</p> <p><i>Response: Please see the section at the beginning of this document called, "NERC Discussion on Proceeding(s) and Directives Regarding: Stable Power Swings" for a complete background.</i></p>
<p>ITC</p>	<p>We are voting Negative primarily for two reasons: 1) the issues we raised need to be addressed to close some gaps and 2) we support the conclusion of SPCS in the PSRPS report that this standard "is not needed, and could result in unintended adverse impacts to Bulk-Power System reliability."</p>

Organization	Question 10 Comment
	<p>Response: Please see the section at the beginning of this document called, “NERC Discussion on Proceeding(s) and Directives Regarding: Stable Power Swings” for a complete background. The SDT understands that NERC staff re-engaged FERC staff following the completion of the PSRPS Report and that the Commission still desired NERC to pursue its work to meet the directive. However, FERC staff was open to an approach designed by NERC. NERC staff has informally received positive feedback on the approach to address the regulatory directive. The directive itself was challenged by commenters prior to the issuance of Order No. 733 and was already the subject of multiple rehearing requests in the Order No. 733-A and Order No. 733-B proceedings. Similar arguments to the conclusions of the NERC System Protection and Control Subcommittee were advanced in these FERC proceedings.</p> <p>As written, the standard only addresses distance and not overcurrent elements. This question was raised in the webinar and a clear answer was not given. The standard refers to “load-responsive” relays, which includes overcurrent, but does not provide criteria for evaluation in R3. Also, should the standard include time-delayed tripping elements, which are commonly ignored for swing tripping consideration?</p> <p>Response: The drafting team added a clarification that standard is applicable to load-responsive protective relays (including overcurrent) which could trip instantaneously or with a time delay of less than 15 cycles. Change made.</p> <p>We also request examples for R3, fourth bullet, of scenarios which do not result in “dependable fault detection or dependable out-of-step tripping”, perhaps in the App Guide. Specifically, we are concerned about load/swings with subsequent phase faults which result in time-delayed tripping when power swing blocking is enabled. Even the most modern SEL-400 relays with zero-setting OOS logic includes additional time delayed tripping for subsequent phase faults. For a standard around swings and stability, delayed fault clearing seems to counterproductive. Is this the scenario which could apply to R3, fourth bullet?</p> <p>Response: The drafting team has concluded that it is possible to comply with the PRC-026-1 – Attachment B, Criteria while providing dependable fault detection or dependable out-of-step tripping and has removed this bullet from Requirement R4 (previously R3).</p>
Public Utility District No. 1 of Cowlitz	We believe this Standard will address a Reliability gap, but also feel that it can overlap into PRC-004. Load responsive relays that trip on a stable power swing should be addressed by PRC-004 as a Protection System Misoperation; subsequently after PRC-004 is satisfied, the affected element should be subject to PRC-026-1 until a repeat is demonstrated to be remote or

Organization	Question 10 Comment
County, WA	<p>nonexistent. However, a violation of PRC-004 should not automatically bleed into a violation of PRC-026-1.</p> <p>Response: There should be no conflict here. If an entity determines a protective relay operation was a Misoperation, it would address the cause of the miss operation under PRC-004. A Misoperation in and of itself is not a violation according to the effective version PRC-004-2.1a. If the operation was due to a stable power swing, then the Element for which the load-responsive relay is applied at the terminals, would then become an identified Element under PRC-026-1.</p>
SPP Standards Review Group	<p>We note that the SPCS concluded that this standard was not needed based on their review and analysis of past disturbances. They went on to say that such a standard ‘...could result in unintended adverse impacts to Bulk-Power System reliability.’ Given their conclusion, has NERC and/or the SDT given any consideration to requesting FERC reconsider their directive to develop this standard?</p> <p>Response: Yes. The drafting team understands that NERC staff re-engaged FERC staff following the completion of the PSRPS Report and that the Commission still desired NERC to pursue its work to meet the directive. However, FERC staff was open to an approach designed by NERC. NERC staff has informally received positive feedback on the approach to address the regulatory directive. The directive itself was challenged by commenters prior to the issuance of Order No. 733 and was already the subject of multiple rehearing requests in the Order No. 733-A and Order No. 733-B proceedings. Similar arguments to the conclusions of the NERC System Protection and Control Subcommittee (SPCS) were advanced in these FERC proceedings.</p> <p>The following are comments on the draft RSAW.</p> <p>We recommend that a specific reference be made to the question of providing evidence based on experience prior to the effective date of the standard. Please see our response to Question 6 above. The industry needs assurances from NERC Compliance that auditors will not be holding responsible entities accountable for providing data on events that occurred prior to the effective date of the standard.</p> <p>The 1st and 2nd cells of the Evidence Requested and Compliance Assessment Approach tables for both Requirements R1 and R2 insert additional requirements that are not contained in the requirements in the standard. These items request evidence/documentation on the methodology and the utilization of that methodology by the responsible entity in the identification of the Elements called for in the two requirements. Neither Requirement R1 nor Requirement R2 mention</p>

Organization	Question 10 Comment
	<p>anything about requiring the responsible entity to 1) have a methodology for performing that identification and 2) use the methodology in the identification process. These items need to be deleted from the RSAW along with the Note to Auditor under the Registered Entity Response for both Requirements R1 and R2. These notes refer to these two items.</p> <p>In the Note to Auditor under the Compliance Assessment Approach Specific to PRC-026-1, R2 replace the ‘all’ at the end of the 3rd line with ‘a’. Still within this section, does the SDT concur with the interpretation of the example at the top of Page 9? If not, we ask that the SDT inform the RSAW developers.</p> <p>Response: Thank you for your comments. The Reliability Standard Audit Worksheet (RSAW) comments have been provided to NERC Compliance as they are responsible for the content of the RSAW.</p>
Xcel Energy	<p>R2 states that elements involved in a power swing since 2003 are targeted for evaluation, with the caveat that the “power swing continues to be credible.” It seems that what constitutes a credible threat is widely open for debate. If it’s not credible once, is it eliminated from consideration going forward?</p> <p>Response: The “January 1, 2003” date has been removed from the standard. Requirement R2 (and new R3) are based on actual Disturbances that occur after the Effective Date of the standard.</p> <p>The term “credible” has been removed from the standard. The drafting team clarified Requirement R1, Criterion 3 by framing the criterion in the present tense to refer to current assessment(s). The term “credible” was removed from the previous Requirement R2 (and new R3) because the required performance refers to only current actual events. Change made.</p>
Associated Electric Cooperative, Inc.	<p>1. This standard is the result of a FERC directive. Yet the reference document entitled “Protection System Response to Power Swings” (the PSRPS document) used to justify the standard does not support the need for the standard. The reference document was prepared by the NERC System Protection and Control Subcommittee and was approved by the NERC Planning Committee. It is posted at <a href="http://www.nerc.com/comm/PC/System%20Protection%20and%20Control%20Subcommittee%20SPCS%2020/SPCS%20Power%20Swing%20Report_Final_20131015.pdf">http://www.nerc.com/comm/PC/System%20Protection%20and%20Control%20Subcommittee%20SPCS%2020/SPCS%20Power%20Swing%20Report_Final_20131015.pdf</a>.</p> <p>Our comments explains this concern and recommends that “the NERC Standards Committee explore means to utilize the more recent PSRPS document to obtain relief from the aforementioned FERC directive that is driving this project.”</p>



Organization	Question 10 Comment
	<p>Response: Please see the section at the beginning of this document called, "NERC Discussion on Proceeding(s) and Directives Regarding: Stable Power Swings" for a complete background. The SDT understands that NERC staff re-engaged FERC staff following the completion of the PSRPS Report and that the Commission still desired NERC to pursue its work to meet the directive. However, FERC staff was open to an approach designed by NERC. NERC staff has informally received positive feedback on the approach to address the regulatory directive. The directive itself was challenged by commenters prior to the issuance of Order No. 733 and was already the subject of multiple rehearing requests in the Order No. 733-A and Order No. 733-B proceedings. Similar arguments to the conclusions of the NERC System Protection and Control Subcommittee were advanced in these FERC proceedings.</p> <p>2. Although we object to the standard in its entirety, R2 is particularly egregious and we are objecting to it so that similar language will never appear in a NERC standard. R2 requires GOs and TOs to evaluate Disturbance records "since January 1, 2003," a time that will precede the effective date of this standard. A requirement cannot rely upon records that precede the effective date of a standard. As an example, PRC-005-1, which was approved in Order 693, became effective on June 11, 2007, does not require a Registered Entity to have maintenance records available for the period of time that preceded the effective date in order to calculate the next maintenance interval for a relay.</p> <p>Response: The "January 1, 2003" date has been removed from the standard. Requirement R2 (and new R3) are based on actual Disturbances that occur after the Effective Date of the standard. Events that occur will be reported to the Planning Coordinator in order to maintain the Element as an "identified Element." Change made.</p>

Additional Comments (Response follows)

Si Truc PHAN

Hydro-QuébecTransÉnergie

Author: .Eric Loiselle, eng. Automatismes, Hydro-Québec TransÉnergie

Date 2014-05-19

Requirement R3 Application Guidelines, Application to Transmission Owners, page 16 to 19

The 120° lens shape criterion with system impedance including all parallel paths defines a boundary limit corresponding to  $Z_{busA\_allowable} = \frac{V_A}{I_{total}}$ . The

Application Guidelines should explain that distance relay R, at the line L of bus A, measures  $I_L$ , and not  $I_{total}$ .  $I_L = I_{total} \times \frac{Z_{TR}}{Z_L + Z_{TR}}$ .

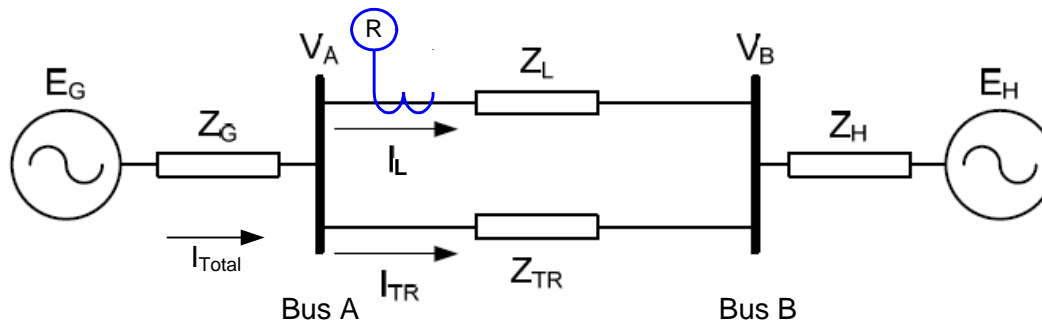


Figure 1<sup>14</sup> : Two- Machine Equivalent of a Power System with Parallel System Transfer Impedance.

<sup>14</sup> Figure 29, SPCS Power Swings Report, 20131015

The distance reach allowable before the relay R trip is:

$$Z_{relayR\_allowable} = \frac{V_A}{I_L}$$

$$= \frac{(Z_L + Z_{TR})}{Z_{TR}} \frac{V_A}{I_{total}}$$

$$Z_{relayR\_allowable} = Z_{busA\_allowable} \frac{(Z_L + Z_{TR})}{Z_{TR}}$$

The distance element of a relay R, measuring  $I_L$ , can be set greater than the distance element of a relay measuring  $I_{total}$ . Therefore, the lens characteristic of the total system impedance cannot directly be compared with the distance characteristic of a line. To juxtapose the two characteristics in the same R-X plane, either the lens or the distance element need to be scaled by a factor  $\frac{(Z_L + Z_{TR})}{Z_{TR}}$ .

Example: Hydro-Quebec 735 kV network

Typical Hydro-Quebec network configuration is 3 parallel 735 kV lines connecting into 2 substations. See figure below.

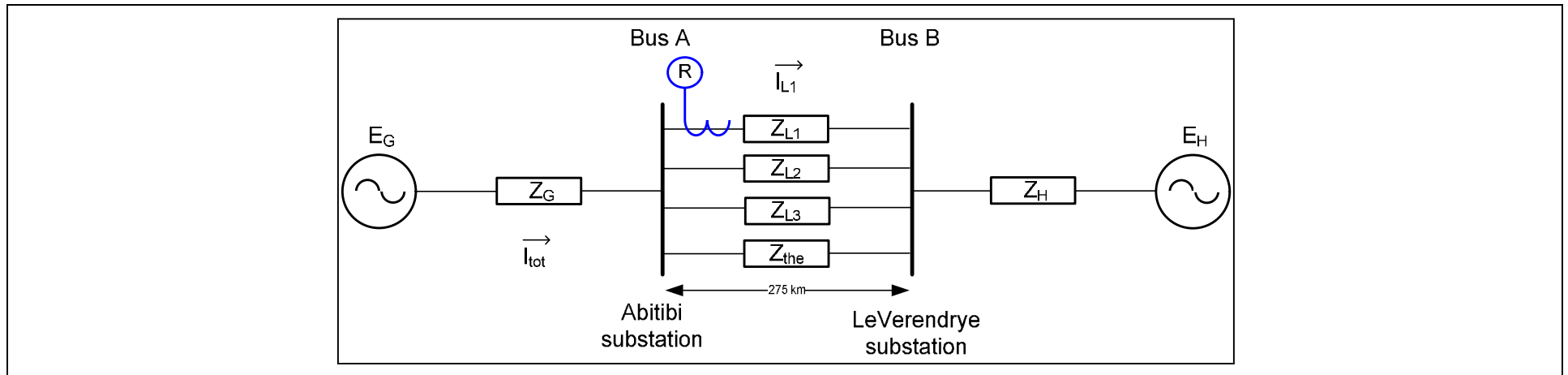


Figure 2: Two- Machine Equivalent of a typical Hydro-Quebec network.

	R	X	Notes
Zg	0,9	23,9	Subtransient impedance, nominal generator and load
ZL1	3,2	55,8	Include -32 j ohms of series compensation CXC
ZL2	2,9	50,6	Include -32 j ohms of series compensation CXC
ZL3	2,9	50,6	Include -32 j ohms of series compensation CXC
Zthe	14,6	325,9	Thevenin equivalent of other links between Bus A and B
Zh	2,1	55,5	Subtransient impedance, nominal generator and load

The 120° lens characteristic and the total system impedance at bus A are drawn at the figure below.

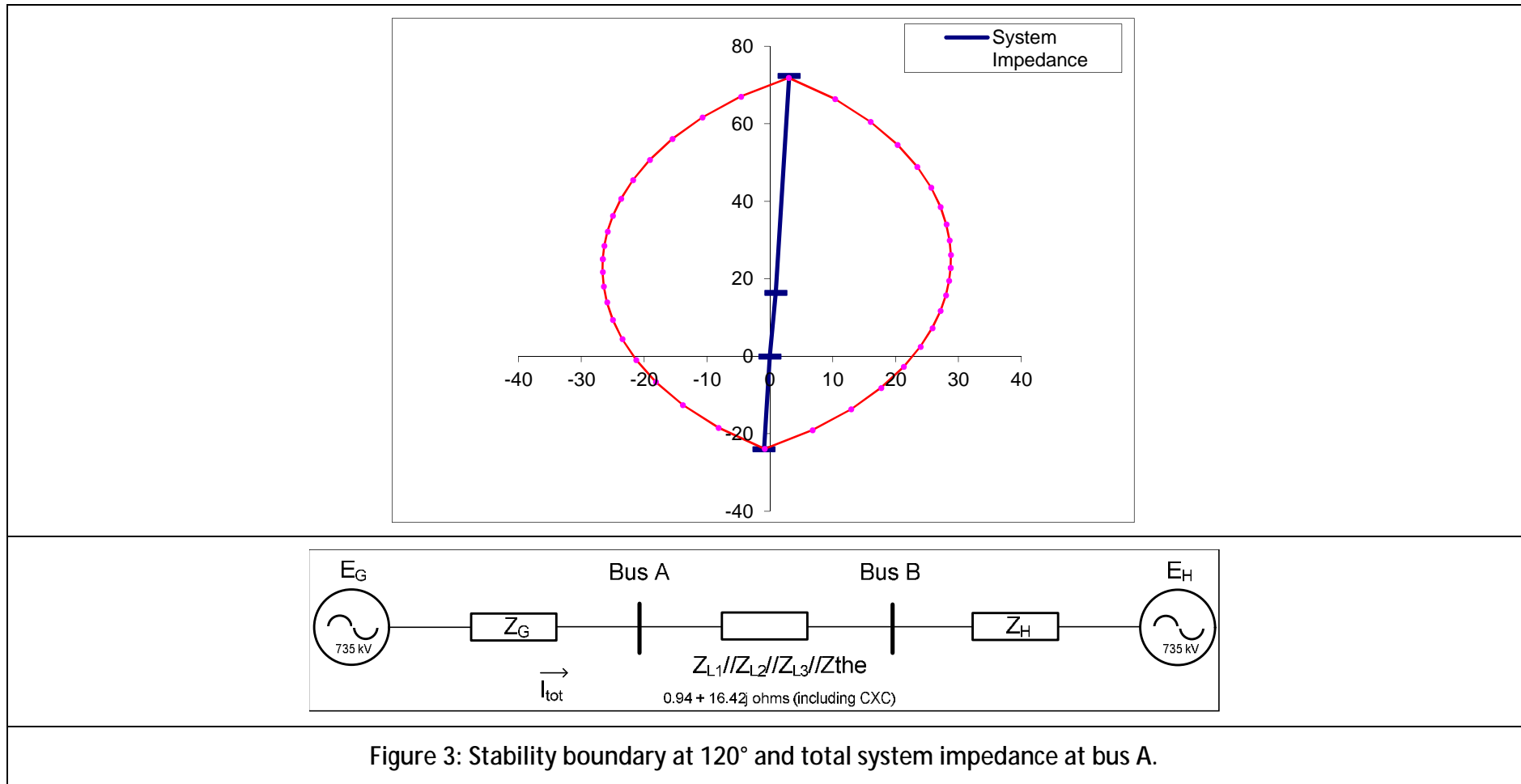
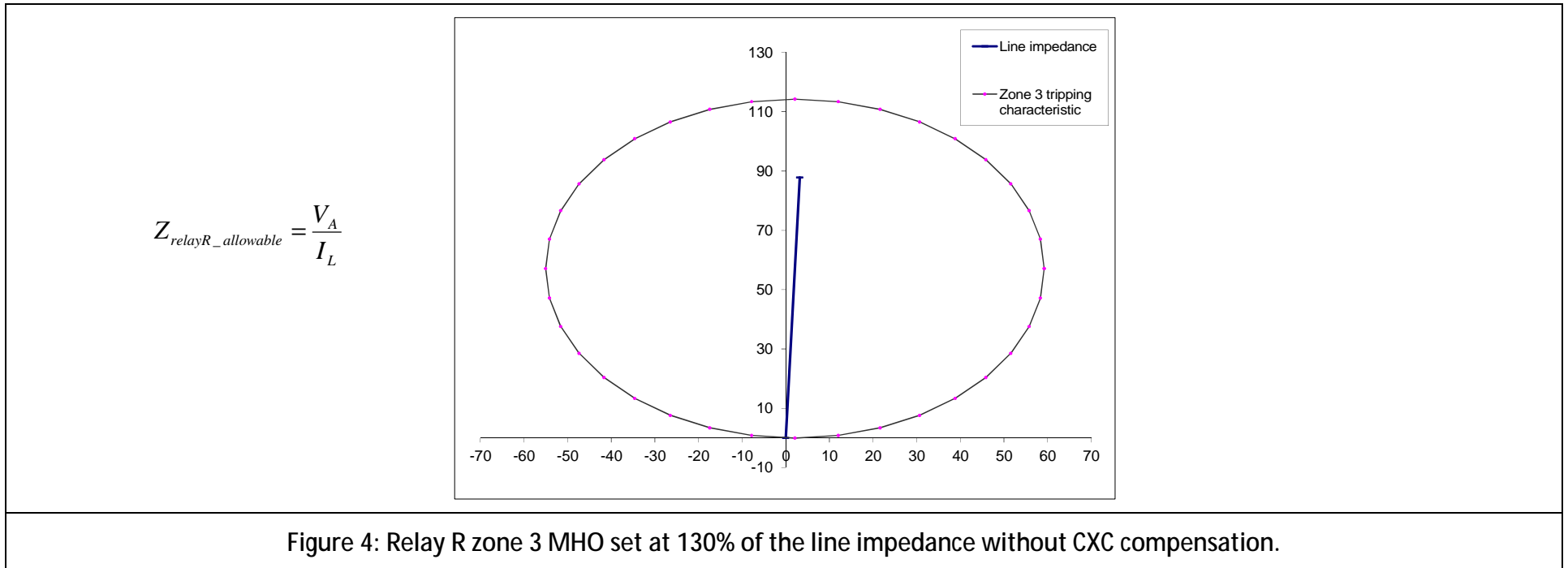


Figure 3: Stability boundary at 120° and total system impedance at bus A.

Typical 735 kV lines are protected by main A and main B current differential protections. Back up distance protection is also used. This distance protection is subject to PRC-026 and need to be evaluated. The larger tripping element of this protection is typically a zone 3 MHO set at 130% of the line impedance without CXC compensation. See next figure.



This distance relay R measures  $I_{L1}$ , not  $I_{total}$ . The distance element of figure 4 cannot be juxtaposed with figure 3 lens shape.

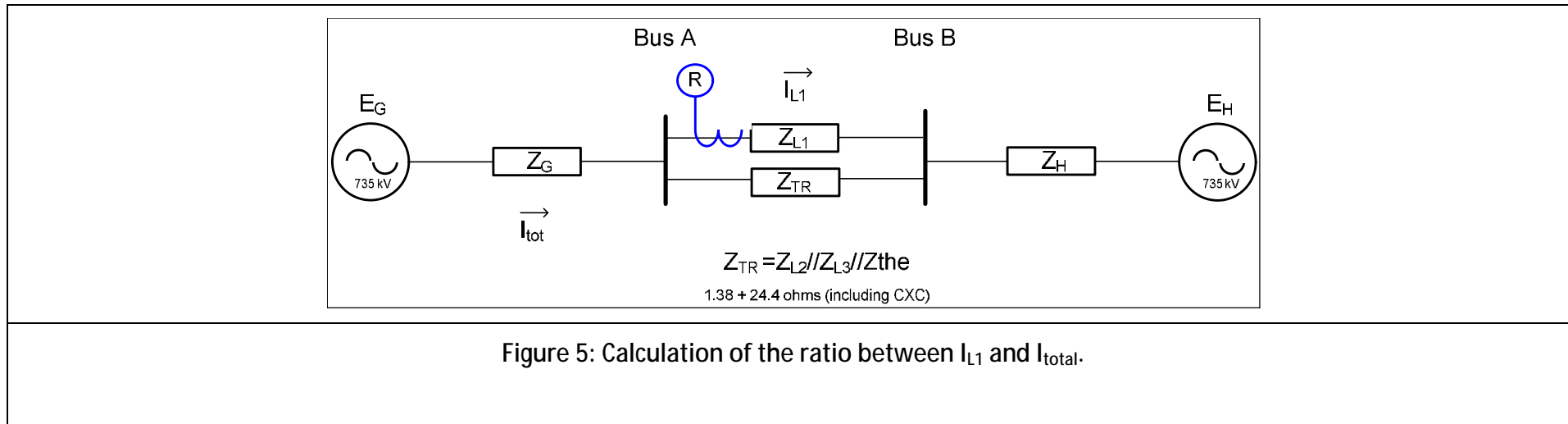


Figure 5: Calculation of the ratio between  $I_{L1}$  and  $I_{total}$ .

$$\frac{(Z_{L1} + Z_{TR})}{Z_{TR}} = 4.6$$

The distance relay measures 1/4.6 of the total system current. Therefore, the zone element of the line 1 is divided by 4.6 before being juxtaposed with the total system boundary stability.

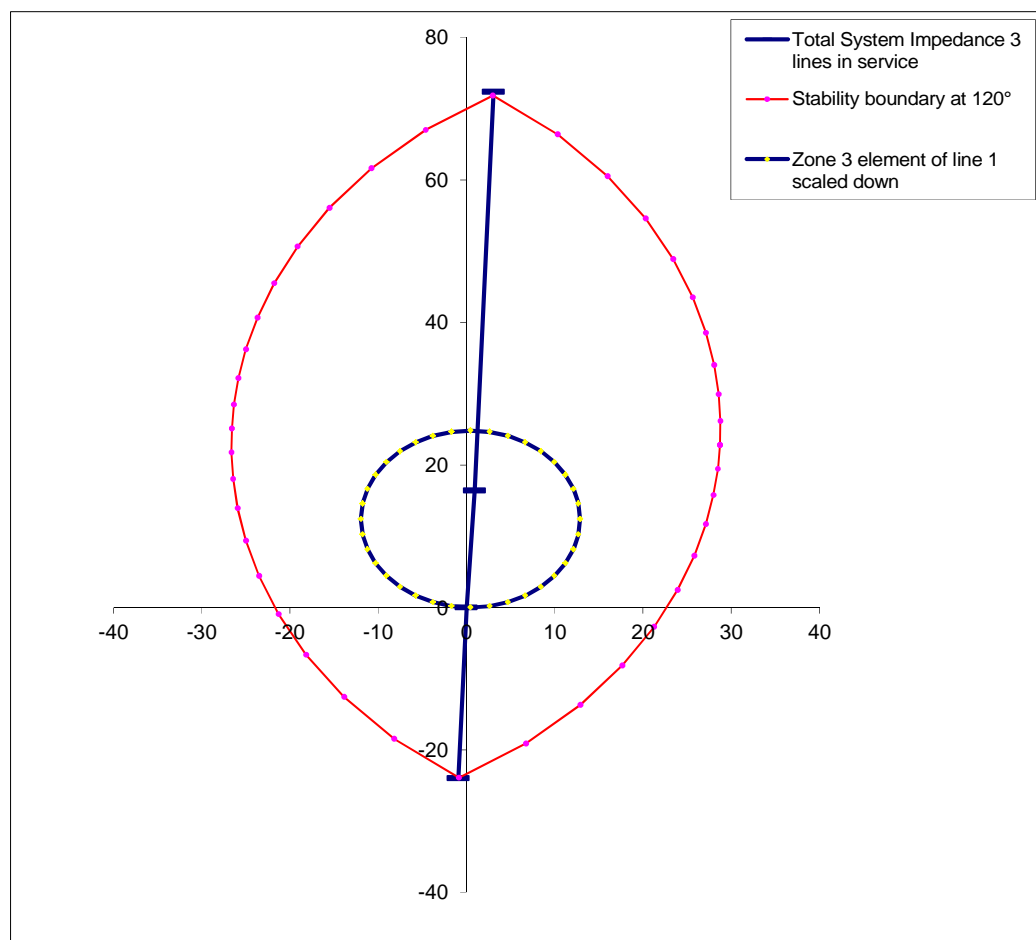


Figure 6: Juxtaposition of zone 3 line element and 120° lens shape, in the total system R-X plane, at bus A



The MHO 130% element is clearly inside the 120° lens characteristic. With three 735 kV lines interconnecting bus A and B, power swings are unlikely to occur. As mentioned by the SPCS power swing report, considering all the parallel transfer impedance is more accurate and allows a greater relay reach.

The 735 kV Hydro-Quebec is more likely to swing when two of the three 735 kV lines are out of service. PRC-026 R3 doesn't impose to evaluate this case. However, it's an interesting topology to study.

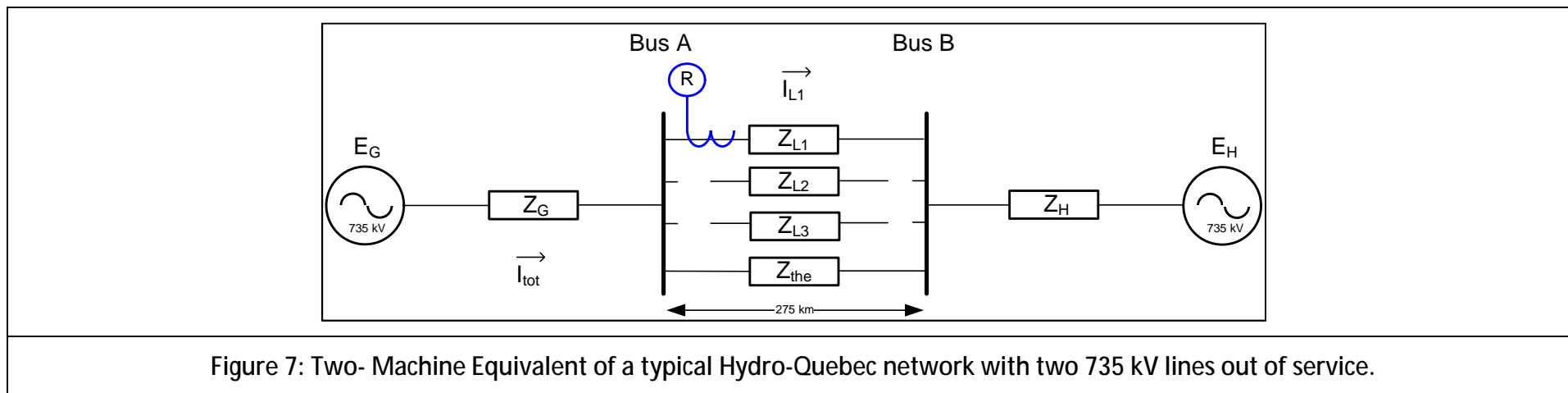


Figure 7: Two-Machine Equivalent of a typical Hydro-Quebec network with two 735 kV lines out of service.

Here, the transfer impedance is increased approximately by three. The line current  $I_{L1}$  measured by the relay R is almost equal to the total system current  $I_{total}$ .

The scale factor is reduced: 
$$\frac{(Z_{L1} + Z_{TR})}{Z_{TR}} = 1.2$$

With this special topology, the MHO Zone 3 element is no more contain within the 120° stability boundary, as shown at the next figure.

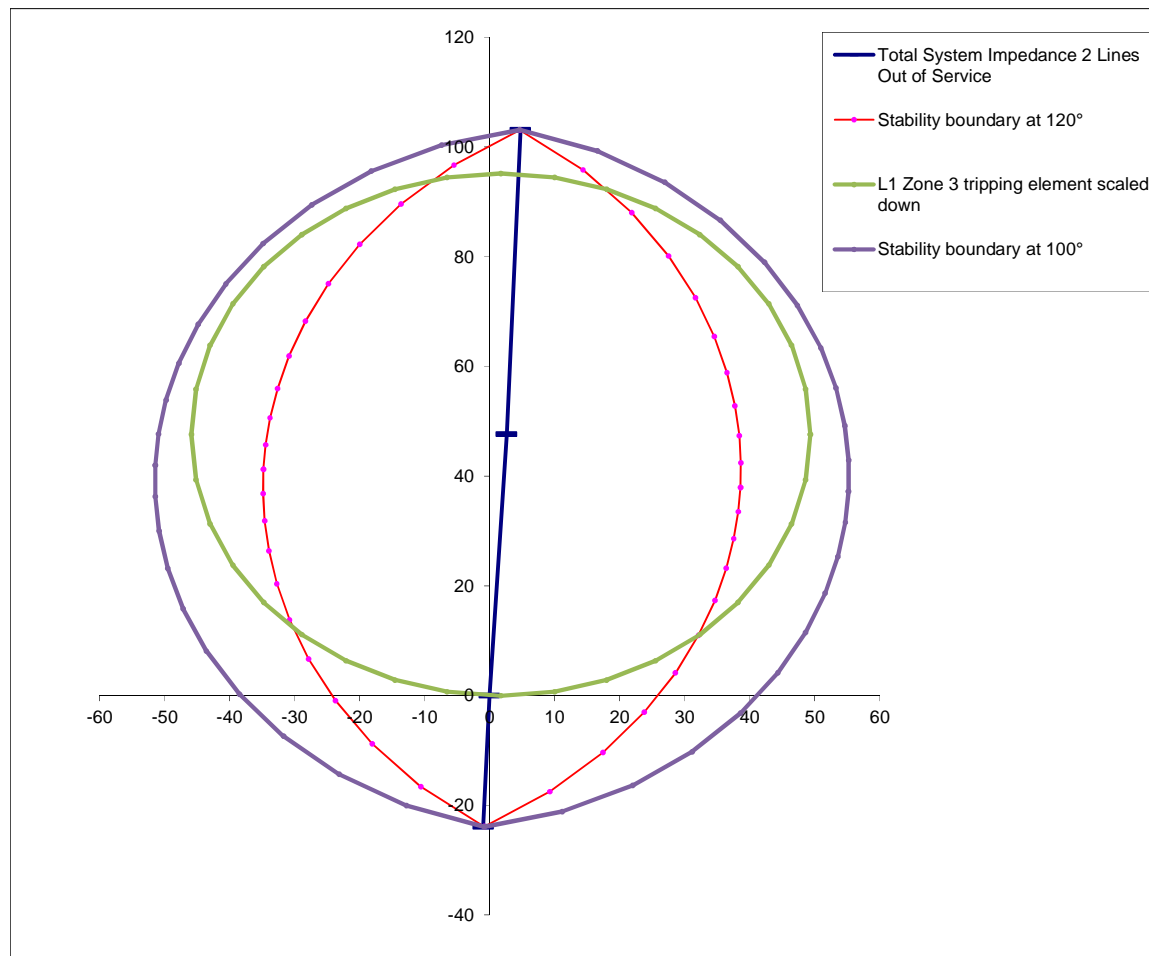


Figure 7: Juxtaposition of zone 3 line element and total system 120° lens shape, in the same R-X plane.

With only one 735 kV in service, nominal generation and load are not allowed. In case of a sudden loss of two 735 kV lines, special protection systems will reject generation and load within 20 cycles. Zg and Zh will be increased, so as the lens shape representing the stability boundary.

The total system impedance of figure 7 can only exist for a maximum of 20 cycles. Zone 3 is a delayed tripping element of 30 cycles. It can be assumed that it won't trip in this condition. As allowed by PRC-026-R3, maybe a reduced stability angle could be used to evaluate this particular topology. The last figure shows that the zone 3 tripping element is within a 100° lens shape.

Response: On May 9, 2014, Eric Loiselle of Hydro-Québec presented a technical document showing that the impedance seen by a relay on a line being evaluated for PRC-026-1 compliance is affected by the parallel transfer impedance in the reduced system network. Inclusion of the transfer impedance in the lens evaluation results in an "apparent lens" impedance as observed by the relay in question that is larger than the observed impedance without the parallel transfer impedance. It was the opinion of Hydro-Quebec that this transfer impedance should be considered when performing the lens evaluation.

The drafting team agrees with the analysis in the technical document presented by Hydro-Quebec, but disagrees with their assessment that the parallel transfer impedance should be included in the lens evaluation.

The drafting team asserts that the parallel transfer impedance should be removed when calculating the total system impedance so that the most conservative portion of a lens characteristic is formed. When the parallel transfer impedance is included, the split in current through the parallel transfer impedance path results in actual measured relay impedances that are larger than those measured when the parallel transfer impedance is removed, which would make it more likely for an impedance relay element to be completely contained within the portion of the lens characteristic. If the transfer impedance is included in the lens evaluation, a distance relay element could be deemed passing, but could subsequently trip for a stable power swing during an actual event if the system was weakened to the point where the lines that make up the parallel transfer impedance were removed.

Other changes have been made to alleviate some of the concerns shown in Hydro-Quebec's example. In their example, they show a zone 3 relay with a trip time delay of 30 cycles. This relay would be exempted from evaluation per the revised Standard since it trips in a time delay of 15 cycles or greater. Also, the lens evaluation in the criteria has been modified to a portion of a lens. The first posted draft 1 of the proposed standard used a complete lens characteristic by varying the system voltages from 0 to 1.0 per unit. Draft 2 of the proposed standard changed this voltage range from 0.7 to 1.0 so that only a portion of a lens is formed. These voltage ranges are more realistic and sufficiently conservative, and will make it more likely for an impedance relay element to meet the criteria.

It was additionally noted in Hydro-Quebec's zone 3 example that it would pass with a system angle of 100 degrees. This reduced system angle is still allowed in the Criteria if a documented stability analysis shows the reduced angle is acceptable.

END OF REPORT

## Standard Development Timeline

*This section is maintained by the drafting team during the development of the standard and will be removed when the standard becomes effective.*

### Development Steps Completed

1. SAR posted for comment from August 19, 2010 through September 19, 2010.
2. SC authorized moving the SAR forward to standard development on August 12, 2010.
3. SC authorized initial posting of draft 1 on April 24, 2014.
4. Draft 1 of PRC-026-1 was posted for a 45-day formal comment period from April 25 – June 9, 2014 and an initial ballot in the last ten days of the comment period from May 30 – June 9, 2014.

### Description of Current Draft

The Protection System Response to Power Swings Standard Drafting Team (PSRPS SDT) is posting Draft 2 of PRC-026-1 – Relay Performance During Stable Power Swings for a 45-day additional comment period and concurrent/parallel additional ballot in the last ten days of the comment period.

Anticipated Actions	Anticipated Date
45-day Formal Comment Period with Concurrent/Parallel Initial Ballot	April 2014
45-day Formal Comment Period with Concurrent/Parallel Additional Ballot	August 2014
Final Ballot	October 2014
NERC Board of Trustees Adoption	November 2014

### Version History

Version	Date	Action	Change Tracking
1.0	TBD	Effective Date	New

**PRC-026-1 — Relay Performance During Stable Power Swings**

---

--	--	--	--

### **Definitions of Terms Used in Standard**

*This section includes all newly defined or revised terms used in the proposed standard. Terms already defined in the Glossary of Terms Used in Reliability Standards are not repeated here. New or revised definitions listed below become approved when the proposed standard is approved. When the standard becomes effective, these defined terms will be removed from the individual standard and added to the Glossary.*

**Term:** None.

*When this standard has received ballot approval, the rationale boxes will be moved to the Application Guidelines Section of the Standard.*

## **A. Introduction**

- 1. Title:** **Relay Performance During Stable Power Swings**
- 2. Number:** **PRC-026-1**
- 3. Purpose:** To ensure that load-responsive protective relays are expected to not trip in response to stable power swings during non-Fault conditions.

- 4. Applicability:**

- 4.1. Functional Entities:**

- 4.1.1** Generator Owner that applies load-responsive protective relays as described in PRC-026-1 – Attachment A at the terminals of the Elements listed in Section 4.2, Facilities.
- 4.1.2** Planning Coordinator.
- 4.1.3** Transmission Owner that applies load-responsive protective relays as described in PRC-026-1 – Attachment A at the terminals of the Elements listed in Section 4.2, Facilities.

- 4.2. Facilities:** The following Bulk Electric System (BES) Elements:

- 4.2.1** Generators.
- 4.2.2** Transformers.
- 4.2.3** Transmission lines.

- 5. Background:**

This is the third phase of a three-phased standard development project that focused on developing this new Reliability Standard to address protective relay operations due to stable power swings. The March 18, 2010, FERC Order No. 733, approved Reliability Standard PRC-023-1 – Transmission Relay Loadability. In this Order, FERC directed NERC to address three areas of relay loadability that include modifications to the approved PRC-023-1, development of a new Reliability Standard to address generator protective relay loadability, and a new Reliability Standard to address the operation of protective relays due to stable power swings. This project's SAR addresses these directives with a three-phased approach to standard development.

Phase 1 focused on making the specific modifications to PRC-023-1 and was completed in the approved Reliability Standard PRC-023-2, which became mandatory on July 1, 2012.

Phase 2 focused on developing a new Reliability Standard, PRC-025-1 – Generator Relay Loadability, to address generator protective relay loadability; PRC-025-1 was approved by FERC on July 17, 2014.



This Phase 3 of the project establishes requirements aimed at preventing protective relays from tripping unnecessarily due to stable power swings by requiring the identification of Elements on which a power swing may affect Protection System operation, and to develop requirements to assess the security of load-responsive protective relays to tripping in response to a stable power swing. Last, to require entities to implement Corrective Action Plans, where necessary, to improve security of security of load-responsive protective relays for stable power swings so they are expected to not trip in response to stable power swings during non-Fault conditions while maintaining dependable fault detection and dependable out-of-step tripping.

**6. Effective Date:**

**Requirements R1-R3, R5, and R6**

First day of the first full calendar year that is 12 months after the date that the standard is approved by an applicable governmental authority or as otherwise provided for in a jurisdiction where approval by an applicable governmental authority is required for a standard to go into effect. Where approval by an applicable governmental authority is not required, the standard shall become effective on the first day of the first full calendar year that is 12 months after the date the standard is adopted by the NERC Board of Trustees or as otherwise provided for in that jurisdiction.

**Requirement R4**

First day of the first full calendar year that is 36 months after the date that the standard is approved by an applicable governmental authority or as otherwise provided for in a jurisdiction where approval by an applicable governmental authority is required for a standard to go into effect. Where approval by an applicable governmental authority is not required, the standard shall become effective on the first day of the first full calendar year that is 36 months after the date the standard is adopted by the NERC Board of Trustees or as otherwise provided for in that jurisdiction.

**B. Requirements and Measures**

**R1.** Each Planning Coordinator shall, at least once each calendar year, identify each Element in its area that meets one or more of the following criteria and provide notification to the respective Generator Owner and Transmission Owner, if any: [*Violation Risk Factor: Medium*] [*Time Horizon: Long-term Planning*]

Criteria:

1. Generator(s) where an angular stability constraint exists that is addressed by an operating limit or a Remedial Action Scheme (RAS) and those Elements terminating at the transmission switching station associated with the generator(s).
2. An Element that is monitored as part of a System Operating Limit (SOL) that has been established based on angular stability constraints identified in system planning or operating studies.
3. An Element that forms the boundary of an island due to angular instability within the most recent underfrequency load shedding (UFLS) assessment.

4. An Element identified in the most recent Planning Assessment where relay tripping occurs due to a stable or unstable power swing during a simulated disturbance.
5. An Element reported by the Generator Owner or Transmission Owner pursuant to Requirement R2 or Requirement R3, unless the Planning Coordinator determines the Element is no longer susceptible to power swings.

**M1.** Each Planning Coordinator shall have dated evidence that demonstrates identification and the respective notification of the Element(s), if any, which meet one or more of the criteria in Requirement R1. Evidence may include, but is not limited to, the following documentation: emails, facsimiles, records, reports, transmittals, lists, or spreadsheets.

**Rationale for R1:** The Planning Coordinator has a wide-area view and is in the position to identify Elements which meet the criteria, if any. The criterion-based approach is consistent with the NERC System Protection and Control Subcommittee (SPCS) technical document *Protection System Response to Power Swings*, August 2013 (“PSRPS Report”),<sup>1</sup> which recommends a focused approach to determine an at-risk Element.

**R2.** Each Transmission Owner shall, within 30 calendar days of identifying an Element that meets either of the following criteria, provide notification of the Element to its Planning Coordinator: [*Violation Risk Factor: Medium*] [*Time Horizon: Long-term Planning*]

Criteria:

1. An Element that trips due to a stable or unstable power swing during an actual system Disturbance due to the operation of its load-responsive protective relays.
2. An Element that forms the boundary of an island during an actual system Disturbance due to the operation of its load-responsive protective relays.

**M2.** Each Transmission Owner shall have dated evidence that demonstrates identification of the Element(s), if any, which meet either of the criteria in Requirement R2. Evidence may include, but is not limited to, the following documentation: emails, facsimiles, records, reports, transmittals, lists, or spreadsheets.

---

<sup>1</sup> NERC System Protection and Control Subcommittee, *Protection System Response to Power Swings*, August 2013: [http://www.nerc.com/comm/PC/System%20Protection%20and%20Control%20Subcommittee%20SPCS%2020/SPCS%20Power%20Swing%20Report\\_Final\\_20131015.pdf](http://www.nerc.com/comm/PC/System%20Protection%20and%20Control%20Subcommittee%20SPCS%2020/SPCS%20Power%20Swing%20Report_Final_20131015.pdf)

**Rationale for R2:** The Transmission Owner is in the position to identify the load-responsive protective relays that have tripped due to power swings, if any. The criteria is consistent with the PSRPS Report. A time to complete a review of the relay tripping is not addressed here as other NERC Reliability Standards address the review of Protection System operations.

**R3.** Each Generator Owner shall, within 30 calendar days of identifying an Element that meets the following criterion, provide notification of the Element to its Planning Coordinator:  
*[Violation Risk Factor: Medium] [Time Horizon: Long-term Planning]*

Criterion:

1. An Element that trips due to a stable or unstable power swing during an actual system Disturbance due to the operation of its load-responsive protective relays.

**M3.** Each Generator Owner shall have dated evidence that demonstrates identification of the Element(s), if any, which the criterion in Requirement R3. Evidence may include, but is not limited to, the following documentation: emails, facsimiles, records, reports, transmittals, lists, or spreadsheets.

**Rationale for R3:** The Generator Owner is in the position to identify the load-responsive protective relays that have tripped due to power swings, if any. The criterion is consistent with the PSRPS Report. A requirement or time to complete a review of the relay tripping is not addressed here as other NERC Reliability Standards address the review of Protection System operations.

**R4.** Each Generator Owner and Transmission Owner shall, within 12 full calendar months of receiving notification of an Element pursuant to Requirement R1 or within 12 full calendar months of identifying an Element pursuant to Requirement R2 or R3, evaluate each identified Element's load-responsive protective relay(s) based on the PRC-026-1 – Attachment B Criteria where the evaluation has not been performed in the last three calendar years. *[Violation Risk Factor: High] [Time Horizon: Operations Planning]*

**M4.** Each Generator Owner and Transmission Owner shall have dated evidence that demonstrates the evaluation was performed according to Requirement R4. Evidence may include, but is not limited to, the following documentation: apparent impedance characteristic plots, email, design drawings, facsimiles, R-X plots, software output, records, reports, transmittals, lists, settings sheets, or spreadsheets.

**Rationale for R4:** Performing the evaluation in Requirement R4 is the first step in ensuring that the reliability goal of this standard will be met. The PRC-026-1 – Attachment B, Criteria provides a basis for determining if the relays are expected to not trip for a stable power swing. See the Guidelines and Technical Basis for a detailed explanation of the evaluation.

- R5.** Each Generator Owner and Transmission Owner shall, within 60 calendar days of an evaluation that identifies load-responsive protective relays that do not meet the PRC-026-1 – Attachment B Criteria pursuant to Requirement R4, develop a Corrective Action Plan (CAP) to modify the Protection System to meet the PRC-026-1 – Attachment B Criteria while maintaining dependable fault detection and dependable out-of-step tripping (if out-of-step tripping is applied at the terminal of the Element). [*Violation Risk Factor: Medium*] [*Time Horizon: Operations Planning*]
- M5.** The Generator Owner and Transmission Owner shall have dated evidence that demonstrates the development of a CAP in accordance with Requirement R5. Evidence may include, but is not limited to, the following documentation: corrective action plans, maintenance records, settings sheets, project or work management program records, or work orders.

**Rationale for R5:** To meet the reliability purpose of the standard, a CAP is necessary to modify the entity’s Protection System to meet PRC-026-1 – Attachment B so that protective relays are expected to not trip in response to stable power swings. The phrase, “while maintaining dependable fault detection and dependable out-of-step tripping” in Requirement R5 describes that the entity is to comply with this standard while achieving their desired protection goals. Refer to the Guidelines and Technical Basis, Introduction, for more information.

- R6.** Each Generator Owner and Transmission Owner shall implement each CAP developed pursuant to Requirement R5, and update each CAP if actions or timetables change until all actions are complete. [*Violation Risk Factor: Medium*][*Time Horizon: Long-Term Planning*]
- M6.** The Generator Owner and Transmission Owner shall have dated evidence that demonstrates implementation of each CAP according to Requirement R6, including updates to actions or timetables. Evidence may include, but is not limited to, the following documentation: corrective action plans, maintenance records, settings sheets, project or work management program records, or work orders.

**Rationale for R6:** Implementation of the CAP must accomplish all identified actions to be complete to achieve the desired reliability goal. During the course of implementing a CAP, updates may be necessary for a variety of reasons such as new information, scheduling conflicts, or resource issues. Documenting changes and completion of activities provides measurable progress and confirmation of completion.

## C. Compliance

### 1. Compliance Monitoring Process

#### 1.1. Compliance Enforcement Authority

As defined in the NERC Rules of Procedure, “Compliance Enforcement Authority” (CEA) means NERC or the Regional Entity in their respective roles of monitoring and enforcing compliance with the NERC Reliability Standards.

#### 1.2. Evidence Retention

The following evidence retention periods identify the period of time an entity is required to retain specific evidence to demonstrate compliance. For instances where the evidence retention period specified below is shorter than the time since the last audit, the CEA may ask an entity to provide other evidence to show that it was compliant for the full time period since the last audit.

The Generator Owner, Planning Coordinator, and Transmission Owner shall keep data or evidence to show compliance as identified below unless directed by its CEA to retain specific evidence for a longer period of time as part of an investigation.

- The Planning Coordinator shall retain evidence of Requirement R1 for a minimum of three calendar years following the completion of each Requirement.
- The Transmission Owner shall retain evidence of Requirement R2 for a minimum of three calendar years following the completion of each Requirement.
- The Generator Owner shall retain evidence of Requirement R3 for a minimum of three calendar years following the completion of each Requirement.
- The Generator Owner and Transmission Owner shall retain evidence of Requirement R4 for a minimum of 36 calendar months following completion of each evaluation.
- The Generator Owner and Transmission Owner shall retain evidence of Requirements R5 and R6, including any supporting analysis per Requirements R1, R2, R3, and R4, for a minimum of 12 calendar months following completion of each CAP.

If a Generator Owner, Planning Coordinator, or Transmission Owner is found non-compliant, it shall keep information related to the non-compliance until mitigation is complete and approved, or for the time specified above, whichever is longer.

The CEA shall keep the last audit records and all requested and submitted subsequent audit records.

#### 1.3. Compliance Monitoring and Assessment Processes:

Compliance Audit

Self-Certification

Spot Checking

Compliance Violation Investigation

Self-Reporting

Complaint

**1.4. Additional Compliance Information**

None.

Table of Compliance Elements

R#	Time Horizon	VRF	Violation Severity Levels			
			Lower VSL	Moderate VSL	High VSL	Severe VSL
R1	Long-term Planning	Medium	The Planning Coordinator identified an Element and provided notification in accordance with Requirement R1, but was less than or equal to 30 calendar days late.	The Planning Coordinator identified an Element and provided notification in accordance with Requirement R1, but was more than 30 calendar days and less than or equal to 60 calendar days late.	The Planning Coordinator identified an Element and provided notification in accordance with Requirement R1, but was more than 60 calendar days and less than or equal to 90 calendar days late.	The Planning Coordinator identified an Element and provided notification in accordance with Requirement R1, but was more than 90 calendar days late. OR The Planning Coordinator failed to identify an Element in accordance with Requirement R1. OR The Planning Coordinator failed to provide notification in accordance with Requirement R1.
R2	Long-term Planning	Medium	The Transmission Owner identified an Element and provided notification in accordance with	The Transmission Owner identified an Element and provided notification in accordance with	The Transmission Owner identified an Element and provided notification in accordance with	The Transmission Owner identified an Element and provided notification in accordance with

R#	Time Horizon	VRF	Violation Severity Levels			
			Lower VSL	Moderate VSL	High VSL	Severe VSL
			Requirement R2, but was less than or equal to 10 calendar days late.	Requirement R2, but was more than 10 calendar days and less than or equal to 20 calendar days late.	Requirement R2, but was more than 20 calendar days and less than or equal to 30 calendar days late.	Requirement R2, but was more than 30 calendar days late. OR The Transmission Owner failed to identify an Element in accordance with Requirement R2. OR The Transmission Owner failed to provide notification in accordance with Requirement R2.
<b>R3</b>	Long-term Planning	Medium	The Generator Owner identified an Element and provided notification in accordance with Requirement R3, but was less than or equal to 10 calendar days late.	The Generator Owner identified an Element and provided notification in accordance with Requirement R3, but was more than 10 calendar days and less than or equal to 20 calendar days late.	The Generator Owner identified an Element and provided notification in accordance with Requirement R3, but was more than 20 calendar days and less than or equal to 30 calendar days late.	The Generator Owner identified an Element and provided notification in accordance with Requirement R3, but was more than 30 calendar days late. OR The Generator Owner failed to identify an



R#	Time Horizon	VRF	Violation Severity Levels			
			Lower VSL	Moderate VSL	High VSL	Severe VSL
						Element in accordance with Requirement R3.  OR  The Generator Owner failed to provide notification in accordance with Requirement R3.
<b>R4</b>	Operations Planning	High	The Generator Owner or Transmission Owner evaluated each identified Element’s load-responsive protective relay(s) in accordance with Requirement R4, but was less than or equal to 30 calendar days late.	The Generator Owner or Transmission Owner evaluated each identified Element’s load-responsive protective relay(s) in accordance with Requirement R4, but was more than 30 calendar days and less than or equal to 60 calendar days late.	The Generator Owner or Transmission Owner evaluated each identified Element’s load-responsive protective relay(s) in accordance with Requirement R4, but was more than 60 calendar days and less than or equal to 90 calendar days late.	The Generator Owner or Transmission Owner evaluated each identified Element’s load-responsive protective relay(s) in accordance with Requirement R4, but was more than 90 calendar days late.  OR  The Generator Owner or Transmission Owner failed to evaluate each identified Element’s load-responsive protective relay(s) in

PRC-026-1 — Relay Performance During Stable Power Swings

R#	Time Horizon	VRF	Violation Severity Levels			
			Lower VSL	Moderate VSL	High VSL	Severe VSL
						accordance with Requirement R4.
<b>R5</b>	Long-term Planning	Medium	The Generator Owner or Transmission Owner developed a CAP in accordance with Requirement R5, but in more than 60 calendar days and less than or equal to 70 calendar days.	The Generator Owner or Transmission Owner developed a CAP in accordance with Requirement R5, but in more than 70 calendar days and less than or equal to 80 calendar days.	The Generator Owner or Transmission Owner developed a CAP in accordance with Requirement R5, but in more than 80 calendar days and less than or equal to 90 calendar days.	The Generator Owner or Transmission Owner developed a CAP in accordance with Requirement R5, but in more than 90 calendar days.  OR The Generator Owner or Transmission Owner failed to develop a CAP in accordance with Requirement R5.
<b>R6</b>	Long-term Planning	Medium	The Generator Owner or Transmission Owner implemented, but failed to update a CAP, when actions or timetables changed, in accordance with Requirement R6.	N/A	N/A	The Generator Owner or Transmission Owner failed to implement a CAP in accordance with Requirement R6.

#### D. Regional Variances

None.

#### E. Interpretations

None.

#### F. Associated Documents

*Applied Protective Relaying*, Westinghouse Electric Corporation, 1979.

Burdy, John, *Loss-of-excitation Protection for Synchronous Generators GER-3183*, General Electric Company.

IEEE Power System Relaying Committee WG D6, *Power Swing and Out-of-Step Considerations on Transmission Lines*, July 2005: <http://www.pes-psrc.org/Reports/Power%20Swing%20and%20OOS%20Considerations%20on%20Transmission%20Lines%20F..pdf>.

Kimbark Edward Wilson, *Power System Stability, Volume II: Power Circuit Breakers and Protective Relays*, Published by John Wiley and Sons, 1950.

Kundar, Prabha, *Power System Stability and Control*, 1994, Palo Alto: EPRI, McGraw Hill, Inc.

NERC System Protection and Control Subcommittee, *Protection System Response to Power Swings*, August 2013: [http://www.nerc.com/comm/PC/System%20Protection%20and%20Control%20Subcommittee%20SPCS%2020/SPCS%20Power%20Swing%20Report\\_Final\\_20131015.pdf](http://www.nerc.com/comm/PC/System%20Protection%20and%20Control%20Subcommittee%20SPCS%2020/SPCS%20Power%20Swing%20Report_Final_20131015.pdf).

Reimert, Donald, *Protective Relaying for Power Generation Systems*, 2006, Boca Raton: CRC Press.

### PRC-026-1 – Attachment A

This standard includes any protective functions which could trip instantaneously or with a time delay of less than 15 cycles, on load current (i.e., “load-responsive”) including, but not limited to:

- Phase distance
- Phase overcurrent
- Out-of-step tripping
- Loss-of-field

The following protection functions are excluded from requirements of this standard:

- Relay elements supervised by power swing blocking
- Relay elements that are only enabled when other relays or associated systems fail. For example:
  - Overcurrent elements that are only enabled during loss of potential conditions.
  - Elements that are only enabled during a loss of communications
- Thermal emulation relays which are used in conjunction with dynamic Facility Ratings
- Relay elements associated with dc lines
- Relay elements associated with dc converter transformers
- Phase fault detector relay elements employed to supervise other load-responsive phase distance elements (e.g., in order to prevent false operation in the event of a loss of potential) provided the distance element is set in accordance with the criteria outlined in the standard
- Relay elements associated with switch-onto-fault schemes
- Reverse power relay on the generator
- Generator relay elements that are armed only when the generator is disconnected from the system, (e.g., non-directional overcurrent elements used in conjunction with inadvertent energization schemes, and open breaker flashover schemes)
- Current differential relay, pilot wire relay, and phase comparison relay
- Voltage-restrained or voltage-controlled overcurrent relays

### PRC-026-1 – Attachment B

#### Criteria A:

An impedance-based relay characteristic, used for tripping, that is completely contained within the portion of the lens characteristic formed in the impedance (R-X) plane that connects the endpoints of the total system impedance (with the parallel transfer impedance removed) bounded by varying the sending- and receiving-end voltages from 0.7 to 1.0 per unit, while maintaining a constant system separation angle across the total system impedance where:

1. The system separation angle is:
  - At least 120 degrees, or
  - An angle less than 120 degrees where a documented transient stability analysis demonstrates the expected maximum stable separation angle is less than 120 degrees.
2. All generation is in service and all transmission Elements are in their normal operating state when calculating the system impedance.
3. Saturated (transient or sub-transient) reactance is used for all machines.

**Rationale for Attachment B (Criteria A):** The PRC-026-1, Attachment B, Criteria A provides a basis for determining if the relays are expected to not trip for a stable power swing having a system separation angle of up to 120 degrees with the sending-end and receiving-end voltages varying from 0.7 to 1.0 per unit (See Guidelines and Technical Basis).

#### Criteria B:

The pickup of an overcurrent relay element used for tripping, that is above the calculated current value (with the parallel transfer impedance removed) for the conditions below:

1. The system separation angle is:
  - At least 120 degrees, or
  - An angle less than 120 degrees where a documented transient stability analysis demonstrates the expected maximum stable separation angle is less than 120 degrees.
2. All generation is in service and all transmission Elements are in their normal operating state when calculating the system impedance.
3. Saturated (transient or sub-transient) reactance is used for all machines.
4. Both the sending and receiving voltages at 1.05 per unit.

**Rationale for Attachment B (Criteria B):** The PRC-026-1, Attachment B, Criteria B provides a basis for determining if the relays are expected to not trip for a stable power swing having a system separation angle of up to 120 degrees with the sending and receiving voltages at 1.05 per unit (See Guidelines and Technical Basis).

### Guidelines and Technical Basis

#### Introduction

The NERC System Protection and Control Subcommittee technical document, *Protection System Response to Power Swings*, August 2013<sup>2</sup> (“PSRPS Report” or “report”) was specifically prepared to support the development of this NERC Reliability Standard. The report provided a historical perspective on power swings as early as 1965 up through the approval of the report by the NERC Planning Committee. The report also addresses reliability issues regarding trade-offs between security and dependability of protection systems, considerations for this NERC Reliability Standard, and a collection of technical information about power swing characteristics and varying issues with practical applications and approaches to power swings. Of these topics, the report suggests an approach for this NERC Reliability Standard (“standard” or “PRC-026-1”) which is consistent with addressing two of the three regulatory directives in the FERC Order No. 733. The first directive concerns the need for “...protective relay systems that differentiate between faults and stable power swings and, when necessary, phases out protective relay systems that cannot meet this requirement.”<sup>3</sup> Second, is “...to develop a Reliability Standard addressing undesirable relay operation due to stable power swings.”<sup>4</sup> The third directive “...to consider “islanding” strategies that achieve the fundamental performance for all islands in developing the new Reliability Standard addressing stable power swings”<sup>5</sup> was considered during development of the standard.

The development of this standard implements the majority of the approach suggested by the report. However, it is noted that the Reliability Coordinator and Transmission Planner have not been included in the standard’s Applicability (as suggested by the PSRPS Report). This is so that a single entity, the Planning Coordinator, may be the single source for identifying Elements according to Requirement R1. A single source will insure that multiple entities will not identify Elements in duplicate, nor will one entity fail to provide an Element because it believes the Element is being provided by another entity. The Planning Coordinator has, or has access to, the wide-area model and can correctly identify the Elements that may be susceptible to a stable power swing.

The phrase, “while maintaining dependable fault detection and dependable out-of-step tripping” in Requirement R1, describes that the Generator Owner and Transmission Owner is to comply with this standard while achieving its desired protection goals. Load-responsive protective relays, as addressed within this standard, may be intended to provide a variety of backup protection functions, both within the generating unit or generating plant and on the Transmission

---

<sup>2</sup> NERC System Protection and Control Subcommittee, *Protection System Response to Power Swings*, August 2013: [http://www.nerc.com/comm/PC/System%20Protection%20and%20Control%20Subcommittee%20SPCS%2020/SPCS%20Power%20Swing%20Report\\_Final\\_20131015.pdf](http://www.nerc.com/comm/PC/System%20Protection%20and%20Control%20Subcommittee%20SPCS%2020/SPCS%20Power%20Swing%20Report_Final_20131015.pdf)

<sup>3</sup> Transmission Relay Loadability Reliability Standard, Order No. 733, P.150 FERC ¶ 61,221 (2010).

<sup>4</sup> Ibid. P.153.

<sup>5</sup> Ibid. P.162.

## Application Guidelines

---

system, and this standard is not intended to result in the loss of these protection functions. Instead, it is suggested that the Generator Owner and Transmission Owner consider both the requirements within this standard and its desired protection goals, and perform modifications to its protective relays or protection philosophies as necessary to achieve both.

### Power Swings

The IEEE Power System Relaying Committee WG D6 developed a technical document called *Power Swing and Out-of-Step Considerations on Transmission Lines* (July 2005) that provides background on power swings. The following are general definitions from that document:<sup>6</sup>

**Power Swing:** a variation in three phase power flow which occurs when the generator rotor angles are advancing or retarding relative to each other in response to changes in load magnitude and direction, line switching, loss of generation, faults, and other system disturbances.

**Pole Slip:** a condition whereby a generator, or group of generators, terminal voltage angles (or phases) go past 180 degrees with respect to the rest of the connected power system.

**Stable Power Swing:** a power swing is considered stable if the generators do not slip poles and the system reaches a new state of equilibrium, i.e. an acceptable operating condition.

**Unstable Power Swing:** a power swing that will result in a generator or group of generators experiencing pole slipping for which some corrective action must be taken.

**Out-of-Step Condition:** Same as an unstable power swing.

**Electrical System Center or Voltage Zero:** it is the point or points in the system where the voltage becomes zero during an unstable power swing.

### Burden to Entities

The PSRPS Report provides a technical basis and approach for focusing on Protection Systems, which are susceptible to power swings while achieving the reliability objective. The approach reduces the number of relays that the PRC-026-1 Requirements would apply to by first identifying the Bulk Electric System (BES) Element(s) that need to be evaluated. The first step uses criteria to identify a BES Element on which a Protection System is expected to be challenged by power swings. Of those BES Elements, the second step is to evaluate each load-responsive protective relay that is applied on each identified Element. Rather than requiring the Transmission Planner to perform simulations to obtain information for each identified Element, the Generator Owner and Transmission Owner will reduce the need for simulation by comparing

---

<sup>6</sup> <http://www.pes-psrc.org/Reports/Power%20Swing%20and%20OOS%20Considerations%20on%20Transmission%20Lines%20F..pdf>.

## Application Guidelines

---

the load-responsive protective relay characteristic to specific criteria found in PRC-026-1 – Attachment B.

### Applicability

The standard is applicable to the Generator Owner, Planning Coordinator, and Transmission Owner entities. More specifically, the Generator Owner and Transmission Owner entities are applicable when applying load-responsive protective relays at the terminals of the applicable BES Elements. All the entities have a responsibility to identify the Elements which meet specific criteria. The standard is applicable to the following BES Elements: generators, transmission lines, and transformers. The Distribution Provider was considered for inclusion in the standard; however, it is not subject to the standard because this entity, by functional registration, would not own generators, transmission lines, or transformers other than load serving.

Load-responsive protective relays include any protective functions which could trip with or without time delay, on load current.

### Requirement R1

The Planning Coordinator has a wide-area view and is in the position to identify what, if any, Elements meet the criteria. The criterion-based approach is consistent with the NERC System Protection and Control Subcommittee (SPCS) technical document *Protection System Response to Power Swings* (August 2013),<sup>7</sup> which recommends a focused approach to determine an at-risk Element. Identification of Elements comes from the annual Planning Assessments pursuant to the transmission planning (i.e., “TPL”) and other NERC Reliability Standards, and the standard is not requiring any other assessments to be performed by the Planning Coordinator. The required annual notification to the respective Generator Owner and Transmission Owner is sufficient because it is expected that the Planning Coordinator will make its notifications following the completion of its annual Planning Assessments.

### Criterion 1

The first criterion involves generator(s) where an angular stability constraint exists which is addressed by an operating limit or a Remedial Action Scheme (RAS) and those Elements terminating at the transmission switching station associated with the generator(s). For example, a scheme to remove generation for specific conditions is implemented for a four-unit generating plant (1,100 MW). Two of the units are 500 MW each; one is connected to the 345 kV system and one is connected to the 230 kV system. The Transmission Owner has two 230 kV transmission lines and one 345 kV transmission line all terminating at the generating facility as well as a 345/230 kV autotransformer. The remaining 100 MW consists of two 50 MW

---

<sup>7</sup> [http://www.nerc.com/comm/PC/System%20Protection%20and%20Control%20Subcommittee%20SPCS%2020/SPCS%20Power%20Swing%20Report\\_Final\\_20131015.pdf](http://www.nerc.com/comm/PC/System%20Protection%20and%20Control%20Subcommittee%20SPCS%2020/SPCS%20Power%20Swing%20Report_Final_20131015.pdf)



## Application Guidelines

---

combustion turbine (CT) units connected to four 66 kV transmission lines. The 66 kV transmission is not electrically joined to the 345 kV and 230 kV transmission lines at the plant site and is not a part of the operating limit or RAS. A stability constraint limits the output of the portion of the plant affected by the RAS to 700 MW for an outage of the 345 kV transmission line. The RAS trips one of the 500 MW units to maintain stability for a loss of the 345 kV transmission line when the total output from both 500 MW units is above 700 MW. For this example, both 500 MW generating units and the associated generator step-up (GSU) transformers would be identified as Elements meeting this criterion. The 345/230 kV autotransformer, the 345 kV transmission line, and the two 230 kV transmission lines would also be identified as Elements meeting this criterion. The 50 MW combustion turbines and 66 kV transmission lines would not be identified pursuant Criterion 1 because these Elements are not subject to an operating limit or RAS and do not terminate at the transmission switching station associated with the generators that are subject to the operating limit and RAS.

### Criterion 2

The second criterion involves Elements that are monitored due to an established System Operating Limit (SOL) based on an angular stability limit regardless of the outage conditions that result in the enforcement of the SOL. For example, if two long parallel 500 kV transmission lines have a combined SOL of 1,200 MW, and this limit is based on angular instability resulting from a fault and subsequent loss of one of the two lines, then both lines would be identified as an Element meeting the criterion.

### Criterion 3

The third criterion involves the Element that forms the boundary of an island due to angular instability within an underfrequency load shedding (UFLS) assessment. While the island may form due to various transmission lines tripping for a combination of reasons, such as stable and unstable power swings, faults, and excessive loading, the criterion requires that all lines that tripped in simulation due to “angular instability” to form the island be identified as meeting the criterion.

### Criterion 4

The fourth criterion involves Elements identified in the most recent Planning Assessment where relay tripping occurs due to a stable or unstable power swing during a simulated disturbance. The intent is for the Planning Coordinator to include any Element(s) where relay tripping was observed during simulations performed for the most recent Planning Assessment associated with the transmission planning TPL-001-4 Reliability Standard. Note that relay tripping must be assessed within Planning Assessments per TPL-001-4, R4, Part 4.3.1.3, which indicates that analysis shall include the “Tripping of Transmission lines and transformers where transient swings cause Protection System operation based on generic or actual relay models.” Identifying such Elements according to criterion 4 and notifying the respective Generator Owner and Transmission Owner will require that the owners of any load-responsive protective relay applied at the terminals of the identified Element evaluate the relay’s susceptibility to tripping in response a stable power swing.

## Application Guidelines

---

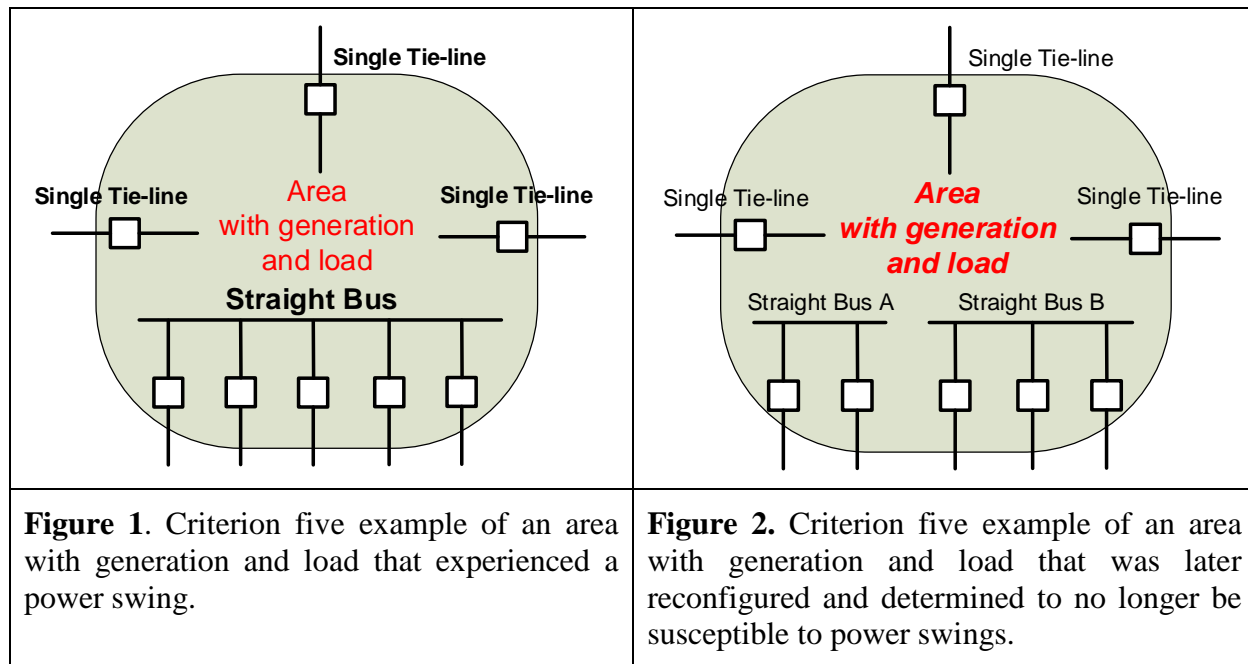
Planning Coordinators have discretion to determine whether observed tripping for a power swing in its Planning Assessments occurs for valid contingencies and system conditions. The Planning Coordinator will address tripping that is observed in transient analyses on an individual basis; therefore, the Planning Coordinator is responsible for identifying the Elements based only on simulation results that are determined to be valid.

Due to the nature of how a Planning Assessment is performed, there may be cases where a previously identified Element is not identified in the most recent Planning Assessment. If so, this is acceptable because the Generator Owner and Transmission Owner would have taken action upon the initial notification of the previously identified Element. When an Element is not identified in later Planning Assessments, the risk would have already been assessed under Requirement R4 and mitigated according to Requirements R5 and R6 when appropriate. According to Requirement R4, the Generator Owner and Transmission Owner are only required to re-evaluate each load-responsive protective relay for an identified Element where the evaluation has not been performed in the last three calendar years.

### Criterion 5

The fifth criterion involves Elements that have actually tripped due to a stable or unstable power swing as reported by the Generator Owner and Transmission Owner. The Planning Coordinator will continue to identify each reported Element until the Planning Coordinator determines that the Element is expected to not trip in response to power swings due to BES configuration changes. For example, eight lines interconnecting areas containing both generation and load to the rest of the BES, and five of the lines terminate on a single straight bus as shown in Figure 1. A forced outage of the straight bus in the past caused an island to form by tripping open the five lines connecting to the straight bus, and subsequently causing the other three lines into the area to trip on power swings. If the BES is reconfigured such that the five lines into the straight bus are now divided between two different substations, the Planning Coordinator may determine that the changes eliminated susceptibility to power swings as shown in Figure 2. If so, the Planning Coordinator is no longer required to identify these Elements previously reported by either the Transmission Owner pursuant to Requirement R2 or Generator Owner pursuant to Requirement R3.

## Application Guidelines



Although Requirement R1 requires the Planning Coordinator to notify the respective Generator Owner and Transmission Owner of any Elements meeting the one or more of the five criteria, it does not preclude the Planning Coordinator from providing additional information, such as apparent impedance characteristics, in advance or upon request, that may be useful in evaluating protective relays. Generator Owners and Transmission Owners are able to complete protective relay evaluations and perform the required actions without additional information. The standard does not include any requirement for the entities to provide information that is already being shared or exchanged between entities for operating needs. While a requirement has not been included for the exchange of information, entities must recognize that relay performance needs to be measured against the most current information.

## Requirement R2

The approach of Requirement R2 requires the Transmission Owner to identify Elements that meet the focused criteria. Only the Elements that meet the criteria and apply a load-responsive protective relay at the terminal of the Element are in scope. Using the criteria focuses the reliability concern on the Element that is at-risk to power swings.

The first criterion involves Elements that have tripped due to a power swing during an actual system Disturbance, regardless of whether the power swing was stable or unstable. Elements that have tripped by unstable power swings are included in this requirement because they were not identified in Requirement R1 and this forms a basis for evaluating the load responsive relay operation for stable power swings. After this standard becomes effective, if it is determined in an outage investigation that an Element tripped because of a power swing condition (either stable or unstable), this standard will become applicable to the Element. An example of an identified Element is an Element tripped by a distance relay element (i.e., a relay with a time delay of less than 15 cycles) during a power swing condition. Another example that would identify an

## **Application Guidelines**

---

Element is where out-of-step (OOS) tripping is applied on the Element, and if a legitimate OOS trip occurred as expected during a power swing event.

The second criterion involves the formation of an island based on an actual system Disturbance. While the island may form due to several transmission lines tripping for a combination of reasons, such as power swings (stable or unstable), faults, or excessive loading, the criterion requires that all Elements that tripped to form the island be identified as meeting this criterion. For example, the Disturbance may have been initiated by one line faulting with a second line being out of service. The outage of those two lines then initiated a swing condition between the “island” and the rest of the system across the remaining ties causing the remaining ties to open. A second case might be that the island could have formed by a fault on one of the other ties with a line out of service with the swing going across the first and second lines mentioned above resulting in those lines opening due to the swing. Therefore, the inclusion of all the Elements that formed the boundary of the island are included as Elements to be reported to the Planning Coordinator.

The owner of the load-responsive protective relay that tripped for either criterion is required to identify the Element and notify its Planning Coordinator. Notifying the Planning Coordinator of the Element ensures that the planner is aware of an Element that is susceptible to a power swing or formed an island. The Planning Coordinator will continue to notify the respective entities of the identified Element under Requirement R1, Criterion 5 unless the Planning Coordinator determines the Element is no longer susceptible to power swings.

### **Requirement R3**

Requirement R3 is similar to Requirement R2, Criterion 1 and requires the Generator Owner to identify any Element that trips due to a power swing condition (stable or unstable) in an actual event. This standard does not focus on the review of Protection Systems because they are covered by other NERC Reliability Standards. When a review of the Generator Owner’s Protection System reveals that tripping occurred due to a power swing, it is required to identify the Element and to notify its Planning Coordinator. Notifying the Planning Coordinator of the Element ensures that the planner is aware of an Element that was susceptible to a power swing. The Planning Coordinator will continue to notify entities of the identified Element under Requirement R1 unless the Planning Coordinator determines the Element is no longer susceptible to power swings.

### **Requirement R4**

Requirement R4 requires the Generator Owner and Transmission Owner to evaluate its load-responsive protective relays applied at all of the terminals of an identified Element to ensure that load-responsive protective relays are expected to not trip in response to stable power swings during non-Fault conditions. A method is provided within the standard to support consistent evaluation by Generator Owners and Transmission Owners based on specified conditions. Once a Generator Owner or Transmission Owner is notified of Elements pursuant to Requirement R1, or once a Generator Owner or Transmission Owner identifies an Element pursuant to Requirement R2 or R3, it has 12 full calendar months to evaluate each Element’s load-

## Application Guidelines

---

responsive protective relays based on the PRC-026-1 – Attachment B, Criteria A and B if the evaluation hasn't been performed in the last three calendar years.

### Information Common to Both Generation and Transmission Elements

The PRC-026-1 – Attachment A lists the load-responsive protective relays that are subject to this standard. Generator Owners and Transmission Owners may own load-responsive protective relays (i.e. distance relays) that directly affect generation or transmission BES Elements and will require analysis as a result of Elements being identified by Requirements R1, R2 or R3. For example, distance relays owned by the Transmission Owner may be installed at the high-voltage side of the generator step-up (GSU) transformer (directional toward the generator) providing backup to generation protection. Generator Owners may have distance relays applied for back-up transmission protection or back-up protection for the GSU transformer. The Generator Owner may have relays installed at the generator terminals or the high-voltage side of the GSU transformer.

### Exclusion of Time Based Load-Responsive Protective Relays

The purpose of the standard is “To ensure that load-responsive protective relays are expected to not trip in response to stable power swings during non-Fault conditions.” Load-responsive protective relays with high-speed tripping pose the highest risk of operating during a power swing. Because of this, high-speed tripping is included in the standard and others (Zone 2 and 3) with a time a delay of 15 cycles or greater are excluded. The time delay used for exclusion on some load-responsive protective relays is recommended based on 1) the minimum time delay these relays are set in practice, and 2) the maximum expected time that load-responsive protective relays would be exposed to the stable swing based on a swing rate.

In order to establish a time delay that strikes a line between a high-risk load-responsive protective relay and one that has a time delay for tripping, a sample of swing rates were calculated based on a stable power swing entering and leaving the impedance characteristic as shown in Table 1. For a relay impedance characteristic that has the swing entering and leaving beginning at 90 degrees with a termination at 120 before exiting the zone, calculation of the timer must be greater than the time the stable swing is inside the relay operate zone.

$$\text{Eq. (1)} \quad \text{Zone time} > 2 \times \left( \frac{(120^\circ - \text{Angle of entry into the relay characteristic})}{\text{Slip Rate}} \right)$$

Table 1. Swing Rates	
Zone Timer (Cycles)	Slip Rate (Hz)
10	1.00
15	0.67
20	0.50
30	0.33

With a minimum zone timer of 15 cycles, the corresponding slip of the system is 0.67 Hz. This represents an approximation of a slow slip rate during a system Disturbance. This value corresponds to the typical minimum time delay used for zone 2 distance relays in transmission line protection. Longer time delays allow for slower slip rates.

### Application to Transmission Elements

The criteria in PRC-026-1 – Attachment B describe a lens characteristic formed in the impedance (R-X) plane that connects the endpoints of the total system impedance together by varying the sending and receiving-end system voltages from 0.7 to 1.0 per unit, while maintaining a constant system separation angle across the total system impedance (with the parallel transfer impedance removed—see Figures 3 through 5). The total system impedance is derived from a two-bus equivalent network and is determined by summing the sending-end source impedance, the line impedance (excluding the Thévenin equivalent transfer impedance), and the receiving-end source impedance as shown in Figures 6 and 7. The goal in establishing the total system impedance is to represent a conservative condition that will maximize the security of the relay against various system conditions. The smallest total system impedance represents a condition where the size of the lens characteristic in the R-X plane is smallest and is a conservative operating point from the standpoint of ensuring a load responsive relay will not trip given a predetermined angular displacement between the sending- and receiving-end voltages. The smallest total system impedance results when all generation is in service and all transmission elements are modeled in their “normal” system configuration (PRC-026-1 – Attachment B, Criteria A). The parallel transfer impedance is removed to represent a likely condition where parallel elements may be lost during the disturbance, and the loss of these elements magnifies the sensitivity of the load-responsive relays on the parallel line by removing the “infeed effect” (i.e., the apparent impedance sensed by the relay is decreased as a result of the loss of the transfer impedance, thus making the relay more likely to trip for a stable power swing).

The sending- and receiving-end source voltages are varied from 0.7 to 1.0 per unit to form a portion of a lens characteristic instead of varying the voltages from 0 to 1.0 per unit, which would form a full-lens characteristic. The ratio of these two voltages is used in the calculation of the portion of the lens, and result in a ratio range from 0.7 to 1.43.

## Application Guidelines

---

$$\text{Eq. (2)} \quad \frac{E_S}{E_R} = \frac{0.7}{1.0} = 0.7$$

$$\text{Eq. (3):} \quad \frac{E_R}{E_S} = \frac{1.0}{0.7} = 1.43$$

The internal generator voltage during severe power swings or transmission system fault conditions will be greater than zero, due to voltage regulator support. The voltage ratio of 0.7 to 1.43 is chosen to be more conservative than the PRC-023 and PRC-025 NERC Reliability Standards, where a lower bound voltage of 0.85 per unit voltage is used. A plus and minus 15% internal generator voltage range was chosen as a conservative voltage range for calculation of the voltage ratio that would determine the end points of the portion of the lens. For example, the voltage ratio using these voltages would result in a ratio range from 0.739 to 1.353.

$$\text{Eq. (4)} \quad \frac{E_S}{E_R} = \frac{0.85}{1.15} = 0.739$$

$$\text{Eq. (5):} \quad \frac{E_R}{E_S} = \frac{1.15}{0.85} = 1.353$$

The lower ratio is rounded down to 0.7 to be more conservative, allowing a voltage range of 0.7 to 1.0 per unit to be used for the calculation of the lens end points.<sup>8</sup>

When the parallel transfer impedance is included in the model, the split in current through the parallel transfer impedance path results in actual measured relay impedances that are larger than those measured when the parallel transfer impedance is removed (i.e., infeed effect), which would make it more likely for an impedance relay element to be completely contained within the applicable portion of the lens characteristic in Figure 11. If the transfer impedance is included in the lens evaluation, a distance relay element could be deemed as meeting PRC-026-1 – Attachment B and, in fact would be secure, assuming all elements were in their normal state. In this case, it could trip for a stable power swing during an actual event if the system was weakened (i.e., a higher transfer impedance) by the loss of a subset of lines that make up the parallel transfer impedance. This could happen because those parallel lines tripped on unstable swings, contained the initiating fault, and/or were lost due to operation of breaker failure or remote back-up protection schemes in Figure 10.

Either the saturated transient or sub-transient direct axis reactance values may be used for machines in the evaluation because they are smaller than un-saturated reactance values. Since, sub-transient saturated generator reactances are smaller than the transient or synchronous reactance, they result in a smaller source impedance and a smaller lens characteristic in the graphical analysis as shown in Figures 8 and 9. Since power swings occur in a time frame where generator transient reactances will be prevalent, it is acceptable to use saturated transient reactances instead of saturated sub-transient reactance values. Some short-circuit models may not include transient reactance values, so in this case, the use of sub-transient is acceptable because it also produces more conservative results than transient reactances. For this reason, either value is

---

<sup>8</sup> *Final Report on the August 14, 2003 Blackout in the United States and Canada: Causes and Recommendations*, April 2004, Section 6 (The Cascade Stage of the Blackout), p. 94 under “Why the Generators Tripped Off,” states, “Some generator undervoltage relays were set to trip at or above 90% voltage. However, a motor stalls out at about 70% voltage and a motor starter contactor drops out around 75%, so if there is a compelling need to protect the turbine from the system the under-voltage trigger point should be no higher than 80%.”

## Application Guidelines

---

acceptable when determining the system source impedances (PRC-026-1 – Attachment B, Criteria A and B, No. 3).

Saturated reactance values are also the values used in short-circuit programs that produce the system impedance mentioned above. Planning and stability software generally use the unsaturated reactance values. Generator models used in transient stability analyses recognize that the extent of the saturation effect depends upon both rotor (field) and stator currents. Accordingly, they derive the effective saturated parameters of the machine at each instant by internal calculation from the specified (constant) unsaturated values of machine reactances and the instantaneous internal flux level. The specific assumptions regarding which inductances are affected by saturation, and the relative effect of that saturation, are different for the various generator models used. Thus, unsaturated values of all machine reactances are used in setting up planning and stability software data, and the appropriate set of open-circuit magnetization curve data is provided for each machine.

The source or system equivalent impedances can be obtained by a number of different methods using commercially available short-circuit calculation tools.<sup>9</sup> Most short-circuit tools have a network reduction feature that allows the user to select the local and remote terminal buses to retain. The first method reduces the system to one that contains two buses, an equivalent generator at each bus (representing the source impedance at the sending- and receiving-ends), and two parallel lines; one being the line impedance of the protected line with relays being analyzed, the other being the transfer impedance representing all other combinations of lines that connect the two buses together in Figure 6. Another conservative method is to open both ends of the line in question, and apply a three-phase bolted fault at each bus. The resulting source impedance at each end will be less than or equal to the actual source impedance calculated by the network reduction method. Either method can be used to develop the system source impedances at both ends.

The two bullets of PRC-026-1 – Attachment B, Criteria A, No. 1, identify the system separation angles to identify the size of the power swing stability boundary to be used to test load-responsive impedance relay elements. Both bullets test impedance relay elements that are not supervised by power swing blocking. The first bullet of PRC-026-1 – Attachment B, Criteria A, No. 1 evaluates a system separation angle of at least 120 degrees that is held constant while varying the sending- and receiving-end source voltages from 0.7 to 1.0 per unit, thus creating a power swing stability boundary shaped like a portion of a lens about the total system impedance in Figure 3. This portion of a lens characteristic is compared to the tripping portion of the distance relay characteristic, that is, the portion that is not supervised by load encroachment, blinders, or some other form of supervision as shown in Figure 12 that restricts the distance element from tripping for heavy, balanced load conditions. If the tripping portion of the impedance characteristics are completely contained within the portion of a lens characteristic, the Element meets Criteria A in PRC-026-1 – Attachment B. A system separation angle of 120

---

<sup>9</sup> Demetrios A. Tziouvaras and Daqing Hou, Appendix in *Out-Of-Step Protection Fundamentals and Advancements*, April 17, 2014: <https://www.selinc.com>.



## Application Guidelines

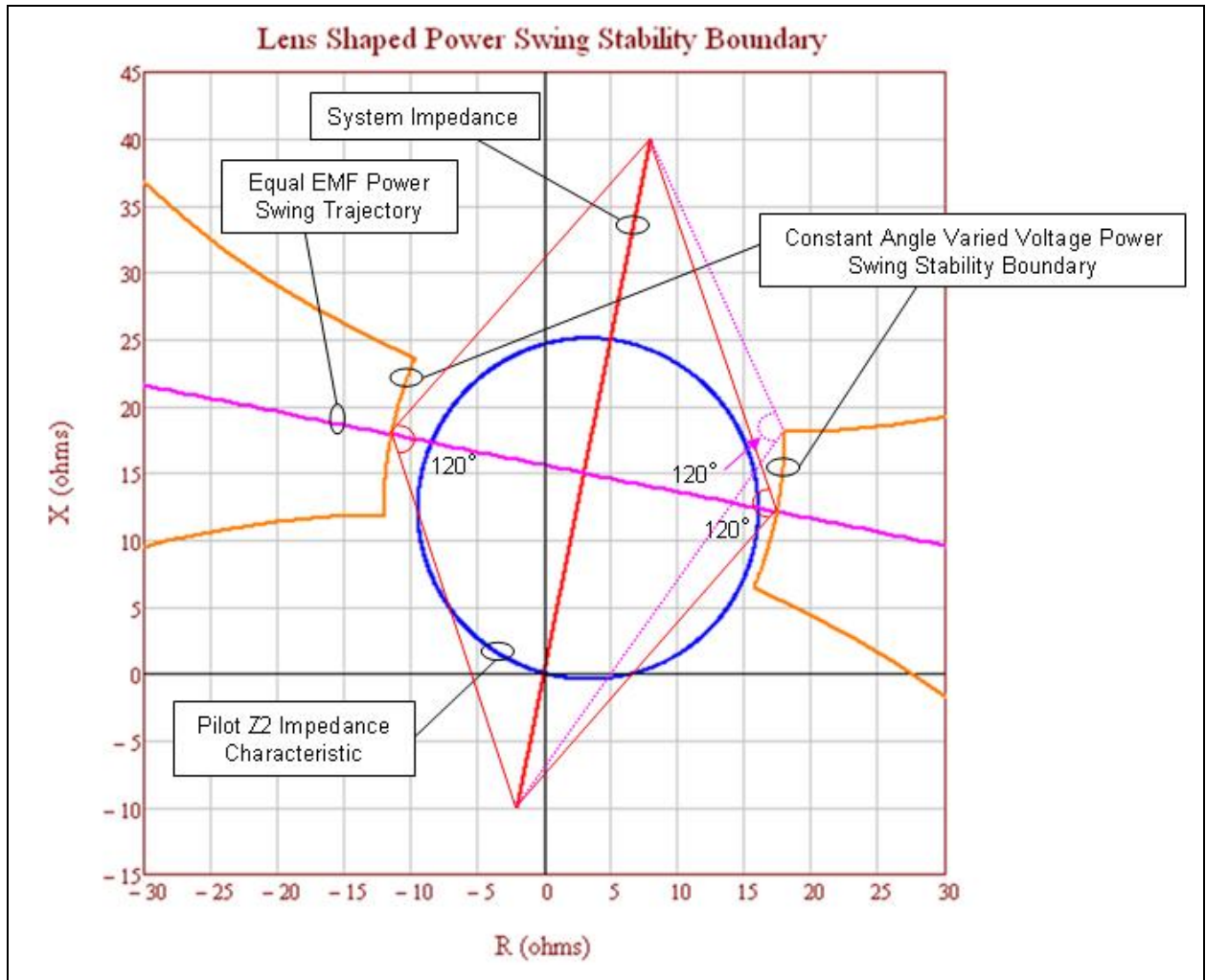
---

degrees was chosen for the evaluation where PSB is not applied because it is generally accepted in the industry that recovery for a swing beyond this angle is unlikely to occur.<sup>10</sup>

The second bullet of PRC-026-1 – Attachment B, Criteria A, No. 1 evaluates impedance relay elements at a system separation angle of less than 120 degrees, similar to the first bullet described above. An angle less than 120 degrees may be used if a documented stability analysis demonstrates that the power swing becomes unstable at a system separation angle of less than 120 degrees.

---

<sup>10</sup> “The critical angle for maintaining stability will vary depending on the contingency and the system condition at the time the contingency occurs; however, the likelihood of recovering from a swing that exceeds 120 degrees is marginal and 120 degrees is generally accepted as an appropriate basis for setting out-of-step protection. Given the importance of separating unstable systems, defining 120 degrees as the critical angle is appropriate to achieve a proper balance between dependable tripping for unstable power swings and secure operation for stable power swings.” NERC System Protection and Control Subcommittee, *Protection System Response to Power Swings*, August 2013: [http://www.nerc.com/comm/PC/System%20Protection%20and%20Control%20Subcommittee%20SPCS%2020/SPCS%20Power%20Swing%20Report\\_Final\\_20131015.pdf](http://www.nerc.com/comm/PC/System%20Protection%20and%20Control%20Subcommittee%20SPCS%2020/SPCS%20Power%20Swing%20Report_Final_20131015.pdf), p. 28.



**Figure 3.** The portion of the lens characteristic that is formed in the impedance (R-X) plane. The pilot zone 2 relay is completely contained within the portion of the lens (e.g., it does not intersect any portion of the partial lens), therefore it complies with PRC-026-1 – Attachment B, Criteria A, No. 1.

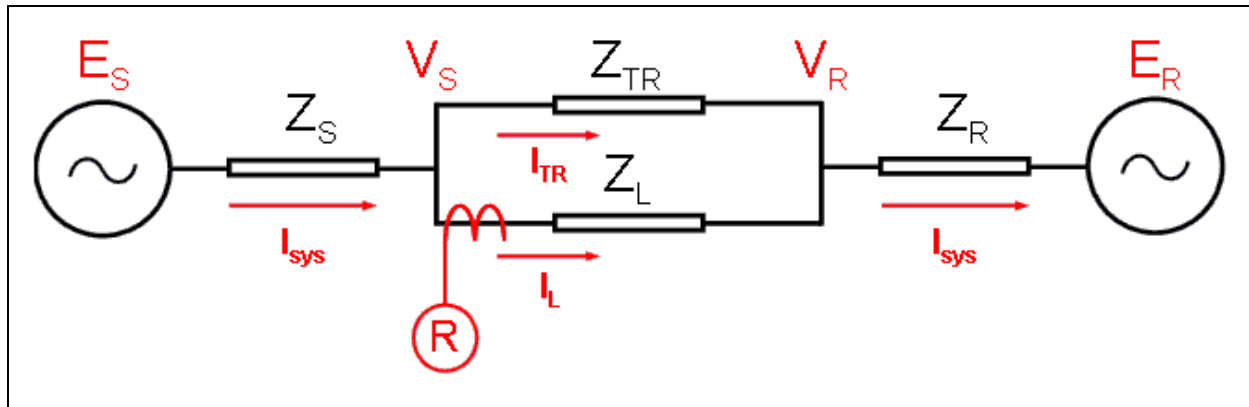
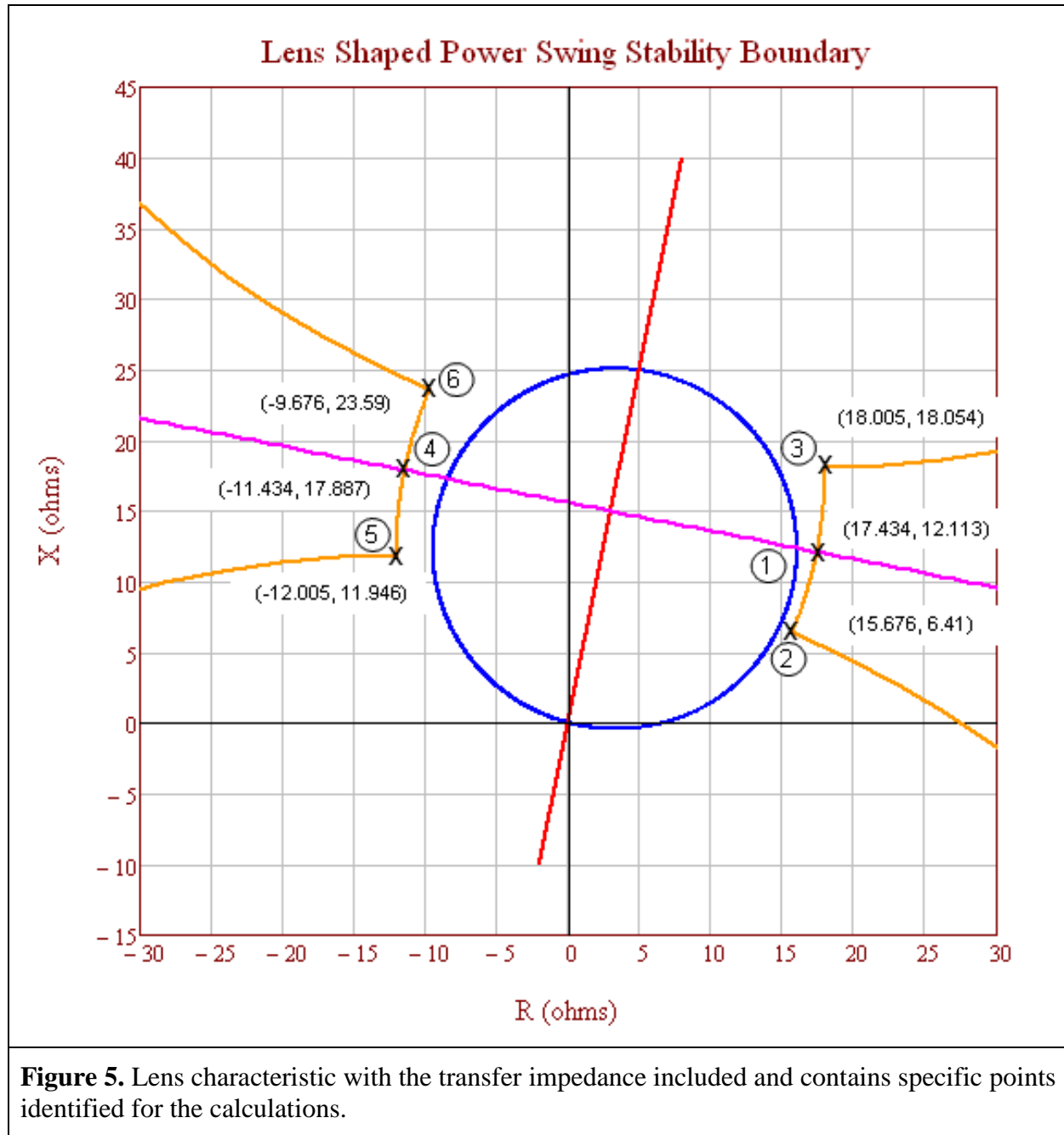


Figure 4. System impedance as seen by relay R.



## Application Guidelines

**Table 2. Example Calculation (Lens Point 1)**

This example is for calculating the impedance the first point of the lens characteristic. Equal source voltages are used for the 230 kV (base) line with the sending voltage ( $E_S$ ) leading the receiving voltage ( $E_R$ ) by 120 degrees. See Figures 4 and 5.

Eq. (6)	$E_S = \frac{V_{LL} \angle 120^\circ}{\sqrt{3}}$		
	$E_S = \frac{230,000 \angle 120^\circ V}{\sqrt{3}}$		
	$E_S = 132,791 \angle 120^\circ V$		
Eq. (7)	$E_R = \frac{V_{LL} \angle 0^\circ}{\sqrt{3}}$		
	$E_R = \frac{230,000 \angle 0^\circ V}{\sqrt{3}}$		
	$E_R = 132,791 \angle 0^\circ V$		
Given positive sequence impedance data (The transfer impedance $Z_{TR}$ is set to infinity).			
Given:	$Z_S = 2 + j10 \Omega$	$Z_L = 4 + j20 \Omega$	$Z_R = 4 + j20 \Omega$
Given:	$Z_{TR} = Z_L \times 10^{10} \Omega$		
Total impedance between generators.			
Eq. (8)	$Z_{total} = \frac{(Z_L \times Z_{TR})}{(Z_L + Z_{TR})}$		
	$Z_{total} = \frac{((4 + j20) \Omega \times (4 + j20)^{10} \Omega)}{((4 + j20) \Omega + (4 + j20)^{10} \Omega)}$		
	$Z_{total} = 4 + j20 \Omega$		
Total system impedance.			
Eq. (9)	$Z_{sys} = Z_S + Z_{total} + Z_R$		
	$Z_{sys} = (2 + j10) \Omega + (4 + j20) \Omega + (4 + j20) \Omega$		
	$Z_{sys} = 10 + j50 \Omega$		

## Application Guidelines

Table 2. Example Calculation (Lens Point 1)	
Total system current from sending source.	
Eq. (10)	$I_{sys} = \frac{E_S - E_R}{Z_{sys}}$
	$I_{sys} = \frac{132,791 \angle 120^\circ V - 132,791 \angle 0^\circ V}{(10 + j50) \Omega}$
	$I_{sys} = 4,511 \angle 71.3^\circ A$
The current as measured by the relay on $Z_L$ is only the current flowing through that line as determined by using the current divider equation.	
Eq. (11)	$I_L = I_{sys} \times \frac{Z_{TR}}{Z_L + Z_{TR}}$
	$I_L = 4,511 \angle 71.3^\circ A \times \frac{(4 + j20)^{10} \Omega}{(4 + j20) \Omega + (4 + j20)^{10} \Omega}$
	$I_L = 4,511 \angle 71.3^\circ A$
The voltage as measured by the relay on $Z_L$ is the voltage drop from the sending source through the sending source impedance.	
Eq. (12)	$V_S = E_S - (Z_S \times I_{sys})$
	$V_S = 132,791 \angle 120^\circ V - [(2 + j10) \Omega \times 4,511 \angle 71.3^\circ A]$
	$V_S = 95,757 \angle 106.1^\circ V$
The impedance seen by the relay on $Z_L$ .	
Eq. (13)	$Z_{L-Relay} = \frac{V_S}{I_L}$
	$Z_{L-Relay} = \frac{95,757 \angle 106.1^\circ V}{4,511 \angle 71.3^\circ A}$
	$Z_{L-Relay} = 17.434 + j12.113 \Omega$

## Application Guidelines

**Table 3. Example Calculation (Lens Point 2)**

This example is for calculating the impedance second point of the lens characteristic. Unequal source voltages are used for the 230 kV (base) line with the sending voltage ( $E_S$ ) at 70% of the receiving voltage ( $E_R$ ) and leading the receiving voltage by 120 degrees. See Figures 4 and 5.

Eq. (14)	$E_S = \frac{V_{LL} \angle 120^\circ}{\sqrt{3}} \times 70\%$		
	$E_S = \frac{230,000 \angle 120^\circ V}{\sqrt{3}} \times 0.70$		
	$E_S = 92,953.7 \angle 120^\circ V$		
Eq. (15)	$E_R = \frac{V_{LL} \angle 0^\circ}{\sqrt{3}}$		
	$E_R = \frac{230,000 \angle 0^\circ V}{\sqrt{3}}$		
	$E_R = 132,791 \angle 0^\circ V$		
Given positive sequence impedance data (The transfer impedance $Z_{TR}$ is set to infinity).			
Given:	$Z_S = 2 + j10 \Omega$	$Z_L = 4 + j20 \Omega$	$Z_R = 4 + j20 \Omega$
Given:	$Z_{TR} = Z_L \times 10^{10} \Omega$		
Total impedance between generators.			
Eq. (16)	$Z_{total} = \frac{(Z_L \times Z_{TR})}{(Z_L + Z_{TR})}$		
	$Z_{total} = \frac{((4 + j20) \Omega \times (4 + j20)^{10} \Omega)}{((4 + j20) \Omega + (4 + j20)^{10} \Omega)}$		
	$Z_{total} = 4 + j20 \Omega$		
Total system impedance.			
Eq. (17)	$Z_{sys} = Z_S + Z_{total} + Z_R$		
	$Z_{sys} = (2 + j10) \Omega + (4 + j20) \Omega + (4 + j20) \Omega$		
	$Z_{sys} = 10 + j50 \Omega$		

## Application Guidelines

Table 3. Example Calculation (Lens Point 2)	
Total system current from sending source.	
Eq. (18)	$I_{sys} = \frac{E_S - E_R}{Z_{sys}}$
	$I_{sys} = \frac{92,953.7 \angle 120^\circ V - 132,791 \angle 0^\circ V}{(10 + j50) \Omega}$
	$I_{sys} = 3,854 \angle 77^\circ A$
The current as measured by the relay on ZL is only the current flowing through that line as determined by using the current divider equation.	
Eq. (19)	$I_L = I_{sys} \times \frac{Z_{TR}}{Z_L + Z_{TR}}$
	$I_L = 3,854 \angle 77^\circ A \times \frac{(4 + j20)^{10} \Omega}{(4 + j20) \Omega + (4 + j20)^{10} \Omega}$
	$I_L = 3,854 \angle 77^\circ A$
The voltage as measured by the relay on Z <sub>L</sub> is the voltage drop from the sending source through the sending source impedance.	
Eq. (20)	$V_S = E_S - (Z_S \times I_{sys})$
	$V_S = 92,953 \angle 120^\circ V - [(2 + j10) \Omega \times 3,854 \angle 77^\circ A]$
	$V_S = 65,271 \angle 99^\circ V$
The impedance seen by the relay on Z <sub>L</sub> .	
Eq. (21)	$Z_{L-Relay} = \frac{V_S}{I_L}$
	$Z_{L-Relay} = \frac{65,271 \angle 99^\circ V}{3,854 \angle 77^\circ A}$
	$Z_{L-Relay} = 15.676 + j6.41 \Omega$



## Application Guidelines

**Table 4. Example Calculation (Lens Point 3)**

This example is for calculating the impedance third point of the lens characteristic. Unequal source voltages are used for the 230 kV (base) line with the receiving voltage ( $E_R$ ) at 70% of the sending voltage ( $E_S$ ) and the sending voltage leading the receiving voltage by 120 degrees. See Figures 4 and 5.

Eq. (22)	$E_S = \frac{V_{LL} \angle 120^\circ}{\sqrt{3}}$		
	$E_S = \frac{230,000 \angle 120^\circ V}{\sqrt{3}}$		
	$E_S = 132,791 \angle 120^\circ V$		
Eq. (23)	$E_R = \frac{V_{LL} \angle 0^\circ}{\sqrt{3}} \times 70\%$		
	$E_R = \frac{230,000 \angle 0^\circ V}{\sqrt{3}} \times 0.70$		
	$E_R = 92,953.7 \angle 0^\circ V$		
Given positive sequence impedance data (The transfer impedance $Z_{TR}$ is set to infinity).			
Given:	$Z_S = 2 + j10 \Omega$	$Z_L = 4 + j20 \Omega$	$Z_R = 4 + j20 \Omega$
Given:	$Z_{TR} = Z_L \times 10^{10} \Omega$		
Total impedance between generators.			
Eq. (24)	$Z_{total} = \frac{(Z_L \times Z_{TR})}{(Z_L + Z_{TR})}$		
	$Z_{total} = \frac{((4 + j20) \Omega \times (4 + j20)^{10} \Omega)}{((4 + j20) \Omega + (4 + j20)^{10} \Omega)}$		
	$Z_{total} = 4 + j20 \Omega$		
Total system impedance.			
Eq. (25)	$Z_{sys} = Z_S + Z_{total} + Z_R$		
	$Z_{sys} = (2 + j10) \Omega + (4 + j20) \Omega + (4 + j20) \Omega$		
	$Z_{sys} = 10 + j50 \Omega$		

## Application Guidelines

Table 4. Example Calculation (Lens Point 3)	
Total system current from sending source.	
Eq. (26)	$I_{sys} = \frac{E_S - E_R}{Z_{sys}}$
	$I_{sys} = \frac{132,791 \angle 120^\circ V - 92,953.7 \angle 0^\circ V}{(10 + j50) \Omega}$
	$I_{sys} = 3,854 \angle 65.5^\circ A$
The current as measured by the relay on ZL is only the current flowing through that line as determined by using the current divider equation.	
Eq. (27)	$I_L = I_{sys} \times \frac{Z_{TR}}{Z_L + Z_{TR}}$
	$I_L = 3,854 \angle 65.5^\circ A \times \frac{(4 + j20)^{10} \Omega}{(4 + j20) \Omega + (4 + j20)^{10} \Omega}$
	$I_L = 3,854 \angle 65.5^\circ A$
The voltage as measured by the relay on ZL is the voltage drop from the sending source through the sending source impedance.	
Eq. (28)	$V_S = E_S - (Z_S \times I_L)$
	$V_S = 132,791 \angle 120^\circ V - [(2 + j10) \Omega \times 3,854 \angle 65.5^\circ A]$
	$V_S = 98,265 \angle 110.6^\circ V$
The impedance seen by the relay on ZL.	
Eq. (29)	$Z_{L-Relay} = \frac{V_S}{I_L}$
	$Z_{L-Relay} = \frac{98,265 \angle 110.6^\circ V}{3,854 \angle 65.5^\circ A}$
	$Z_{L-Relay} = 18.005 + j18.054 \Omega$

## Application Guidelines

**Table 5. Example Calculation (Lens Point 4)**

This example is for calculating the impedance fourth point of the lens characteristic. Equal source voltages are used for the 230 kV (base) line with the sending voltage (ES) leading the receiving voltage (ER) by 240 degrees. See Figures 4 and 5.

Eq. (30)	$E_S = \frac{V_{LL} \angle 240^\circ}{\sqrt{3}}$		
	$E_S = \frac{230,000 \angle 240^\circ V}{\sqrt{3}}$		
	$E_S = 132,791 \angle 240^\circ V$		
Eq. (31)	$E_R = \frac{V_{LL} \angle 0^\circ}{\sqrt{3}}$		
	$E_R = \frac{230,000 \angle 0^\circ V}{\sqrt{3}}$		
	$E_R = 132,791 \angle 0^\circ V$		
Given positive sequence impedance data (The transfer impedance $Z_{TR}$ is set to infinity).			
Given:	$Z_S = 2 + j10 \Omega$	$Z_L = 4 + j20 \Omega$	$Z_R = 4 + j20 \Omega$
Given:	$Z_{TR} = Z_L \times 10^{10} \Omega$		
Total impedance between generators.			
Eq. (32)	$Z_{total} = \frac{(Z_L \times Z_{TR})}{(Z_L + Z_{TR})}$		
	$Z_{total} = \frac{((4 + j20) \Omega \times (4 + j20)^{10} \Omega)}{((4 + j20) \Omega + (4 + j20)^{10} \Omega)}$		
	$Z_{total} = 4 + j20 \Omega$		
Total system impedance.			
Eq. (33)	$Z_{sys} = Z_S + Z_{total} + Z_R$		
	$Z_{sys} = (2 + j10) \Omega + (4 + j20) \Omega + (4 + j20) \Omega$		
	$Z_{sys} = 10 + j50 \Omega$		

Table 5. Example Calculation (Lens Point 4)	
Total system current from sending source.	
Eq. (34)	$I_{sys} = \frac{E_S - E_R}{Z_{sys}}$
	$I_{sys} = \frac{132,791 \angle 240^\circ V - 132,791 \angle 0^\circ V}{(10 + j50) \Omega}$
	$I_{sys} = 4,510 \angle 131.3^\circ A$
The current as measured by the relay on ZL is only the current flowing through that line as determined by using the current divider equation.	
Eq. (35)	$I_L = I_{sys} \times \frac{Z_{TR}}{Z_L + Z_{TR}}$
	$I_L = 4,510 \angle 131.1^\circ A \times \frac{(4 + j20)^{10} \Omega}{(4 + j20) \Omega + (4 + j20)^{10} \Omega}$
	$I_L = 4,510 \angle 131.1^\circ A$
The voltage as measured by the relay on ZL is the voltage drop from the sending source through the sending source impedance.	
Eq. (36)	$V_S = E_S - (Z_S \times I_L)$
	$V_S = 132,791 \angle 240^\circ V - [(2 + j10) \Omega \times 4,510 \angle 131.1^\circ A]$
	$V_S = 95,756 \angle -106.1^\circ V$
The impedance seen by the relay on ZL.	
Eq. (37)	$Z_{L-Relay} = \frac{V_S}{I_L}$
	$Z_{L-Relay} = \frac{95,756 \angle -106.1^\circ V}{4,510 \angle 131.1^\circ A}$
	$Z_{L-Relay} = -11.434 + j17.887 \Omega$

## Application Guidelines

**Table 6. Example Calculation (Lens Point 5)**

This example is for calculating the impedance fifth point of the lens characteristic. Unequal source voltages are used for the 230 kV (base) line with the sending voltage ( $E_S$ ) at 70% of the receiving voltage ( $E_R$ ) and leading the receiving voltage by 240 degrees. See Figures 4 and 5.

Eq. (38)	$E_S = \frac{V_{LL} \angle 240^\circ}{\sqrt{3}} \times 70\%$		
	$E_S = \frac{230,000 \angle 240^\circ V}{\sqrt{3}} \times 0.70$		
	$E_S = 92,953.7 \angle 240^\circ V$		
Eq. (39)	$E_R = \frac{V_{LL} \angle 0^\circ}{\sqrt{3}}$		
	$E_R = \frac{230,000 \angle 0^\circ V}{\sqrt{3}}$		
	$E_R = 132,791 \angle 0^\circ V$		
Given positive sequence impedance data (The transfer impedance $Z_{TR}$ is set to infinity).			
Given:	$Z_S = 2 + j10 \Omega$	$Z_L = 4 + j20 \Omega$	$Z_R = 4 + j20 \Omega$
Given:	$Z_{TR} = Z_L \times 10^{10} \Omega$		
Total impedance between generators.			
Eq. (40)	$Z_{total} = \frac{(Z_L \times Z_{TR})}{(Z_L + Z_{TR})}$		
	$Z_{total} = \frac{((4 + j20) \Omega \times (4 + j20)^{10} \Omega)}{((4 + j20) \Omega + (4 + j20)^{10} \Omega)}$		
	$Z_{total} = 4 + j20 \Omega$		
Total system impedance.			
Eq. (41)	$Z_{sys} = Z_S + Z_{total} + Z_R$		
	$Z_{sys} = (2 + j10 \Omega) + (4 + j20 \Omega) + (4 + j20 \Omega)$		
	$Z_{sys} = 10 + j50 \Omega$		

Table 6. Example Calculation (Lens Point 5)	
Total system current from sending source.	
Eq. (42)	$I_{sys} = \frac{E_S - E_R}{Z_{sys}}$
	$I_{sys} = \frac{92,953.7 \angle 240^\circ V - 132,791 \angle 0^\circ V}{10 + j50 \Omega}$
	$I_{sys} = 3,854 \angle 125.5^\circ A$
The current as measured by the relay on $Z_L$ is only the current flowing through that line as determined by using the current divider equation.	
Eq. (43)	$I_L = I_{sys} \times \frac{Z_{TR}}{Z_L + Z_{TR}}$
	$I_L = 3,854 \angle 125.5^\circ A \times \frac{(4 + j20)^{10} \Omega}{(4 + j20) \Omega + (4 + j20)^{10} \Omega}$
	$I_L = 3,854 \angle 125.5^\circ A$
The voltage as measured by the relay on $Z_L$ is the voltage drop from the sending source through the sending source impedance.	
Eq. (44)	$V_S = E_S - (Z_S \times I_L)$
	$V_S = 92,953.7 \angle 240^\circ V - [(2 + j10) \Omega \times 3,854 \angle 125.5^\circ A]$
	$V_S = 65,270.5 \angle -99.4^\circ V$
The impedance seen by the relay on $Z_L$ .	
Eq. (45)	$Z_{L-Relay} = \frac{V_S}{I_L}$
	$Z_{L-Relay} = \frac{65,270.5 \angle -99.4^\circ V}{3,854 \angle 125.5^\circ A}$
	$Z_{L-Relay} = -12.005 + j11.946 \Omega$

## Application Guidelines

**Table 7. Example Calculation (Lens Point 6)**

This example is for calculating the impedance sixth point of the lens characteristic. Unequal source voltages are used for the 230 kV (base) line with the receiving voltage ( $E_R$ ) at 70% of the sending voltage ( $E_S$ ) and the sending voltage leading the receiving voltage by 240 degrees. See Figures 4 and 5.

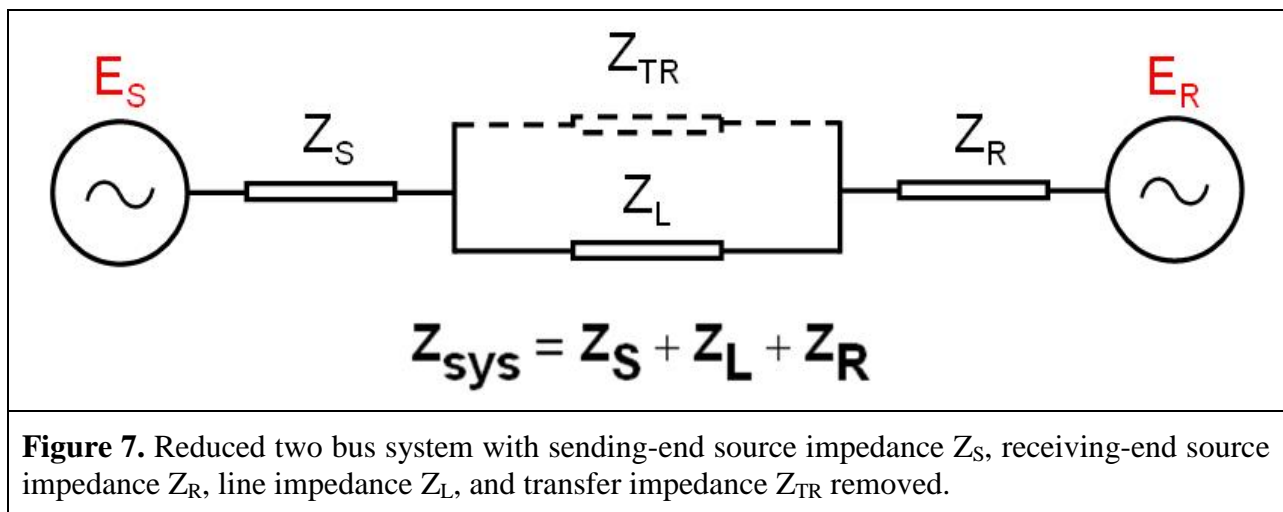
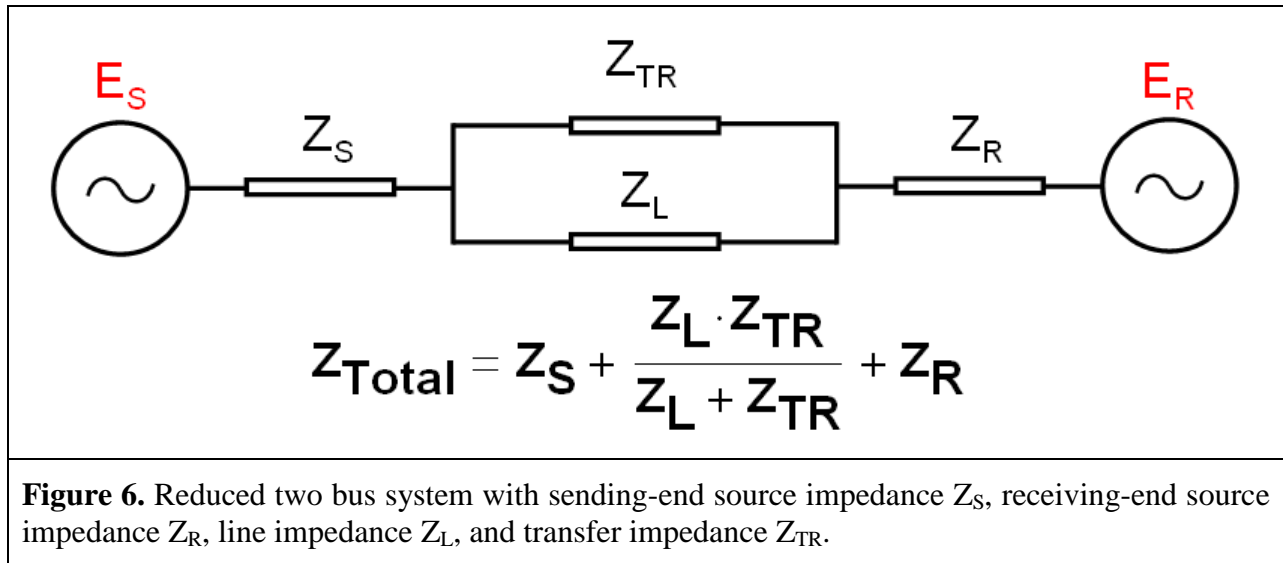
Eq. (46)	$E_S = \frac{V_{LL} \angle 240^\circ}{\sqrt{3}}$		
	$E_S = \frac{230,000 \angle 240^\circ V}{\sqrt{3}}$		
	$E_S = 132,791 \angle 240^\circ V$		
Eq. (47)	$E_R = \frac{V_{LL} \angle 0^\circ}{\sqrt{3}} \times 70\%$		
	$E_R = \frac{230,000 \angle 0^\circ V}{\sqrt{3}} \times 0.70$		
	$E_R = 92,953.7 \angle 0^\circ V$		
Given positive sequence impedance data (The transfer impedance $Z_{TR}$ is set to infinity).			
Given:	$Z_S = 2 + j10 \Omega$	$Z_L = 4 + j20 \Omega$	$Z_R = 4 + j20 \Omega$
Given:	$Z_{TR} = Z_L \times 10^{10} \Omega$		
Total impedance between generators.			
Eq. (48)	$Z_{total} = \frac{(Z_L \times Z_{TR})}{(Z_L + Z_{TR})}$		
	$Z_{total} = \frac{((4 + j20) \Omega \times (4 + j20)^{10} \Omega)}{((4 + j20) \Omega + (4 + j20)^{10} \Omega)}$		
	$Z_{total} = 4 + j20 \Omega$		
Total system impedance.			
Eq. (49)	$Z_{sys} = Z_S + Z_{total} + Z_R$		
	$Z_{sys} = (2 + j10) \Omega + (4 + j20) \Omega + (4 + j20) \Omega$		
	$Z_{sys} = 10 + j50 \Omega$		

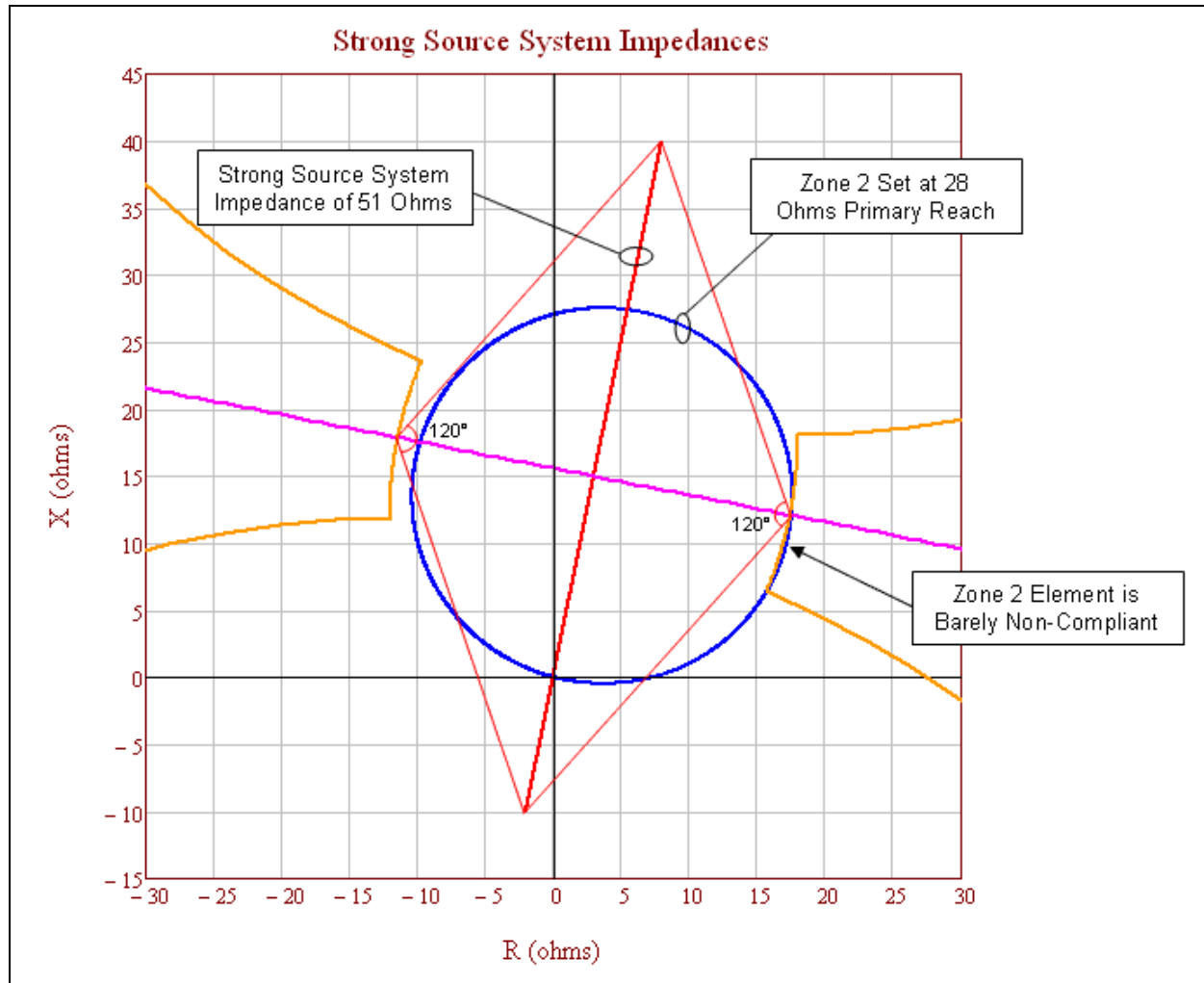
## Application Guidelines

Table 7. Example Calculation (Lens Point 6)	
Total system current from sending source.	
Eq. (50)	$I_{sys} = \frac{E_S - E_R}{Z_{sys}}$
	$I_{sys} = \frac{132,791 \angle 240^\circ V - 92,953.7 \angle 0^\circ V}{10 + j50 \Omega}$
	$I_{sys} = 3,854 \angle 137.1^\circ A$
The current as measured by the relay on $Z_L$ is only the current flowing through that line as determined by using the current divider equation.	
Eq. (51)	$I_L = I_{sys} \times \frac{Z_{TR}}{Z_L + Z_{TR}}$
	$I_L = 3,854 \angle 137.1^\circ A \times \frac{(4 + j20)^{10} \Omega}{(4 + j20) \Omega + (4 + j20)^{10} \Omega}$
	$I_L = 3,854 \angle 137.1^\circ A$
The voltage as measured by the relay on $Z_L$ is the voltage drop from the sending source through the sending source impedance.	
Eq. (52)	$V_S = E_S - (Z_S \times I_L)$
	$V_S = 132,791 \angle 240^\circ V - [(2 + j10) \Omega \times 3,854 \angle 137.1^\circ A]$
	$V_S = 98,265 \angle -110.6^\circ V$
The impedance seen by the relay on $Z_L$ .	
Eq. (53)	$Z_{L-Relay} = \frac{V_S}{I_L}$
	$Z_{L-Relay} = \frac{98,265 \angle -110.6^\circ V}{3,854 \angle 137.1^\circ A}$
	$Z_{L-Relay} = -9.676 + j23.59 \Omega$



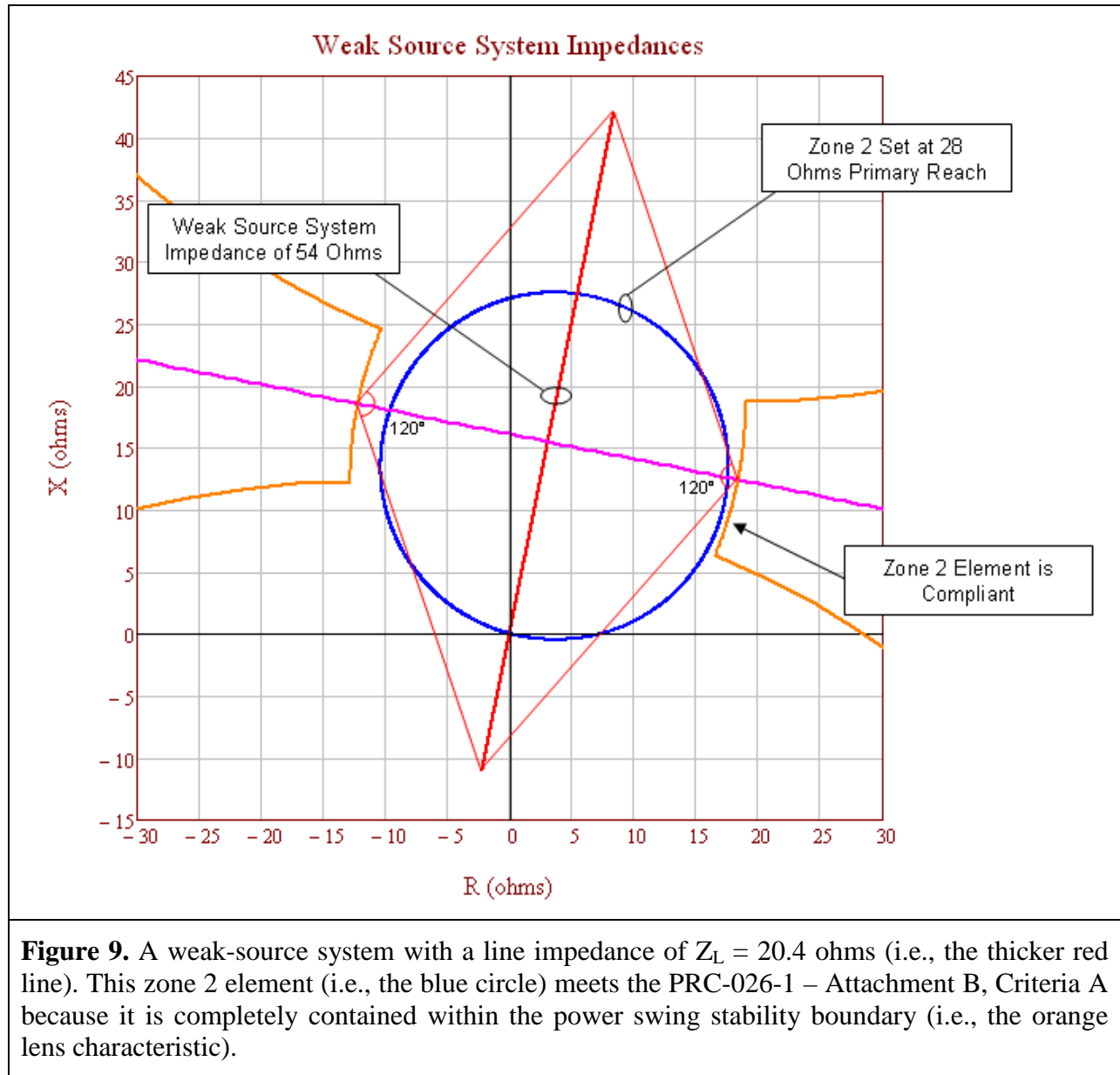
## Application Guidelines





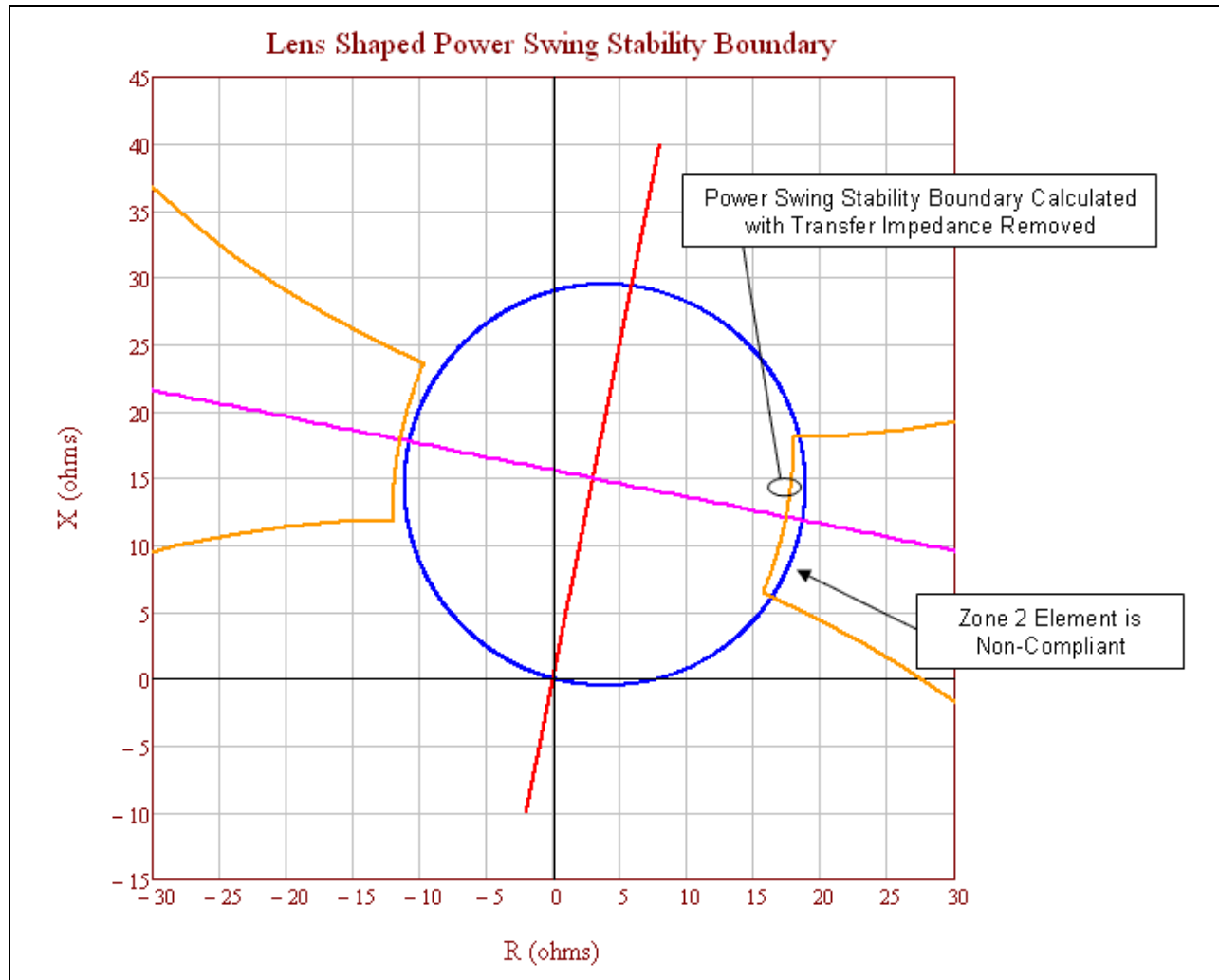
**Figure 8.** A strong-source system with a line impedance of  $Z_L = 20.4$  ohms (i.e., the thicker red line). This relay element (i.e., the blue circle) does not meet the PRC-026-1 – Attachment B, Criteria A because it is not completely contained within the power swing stability boundary (i.e., the orange lens characteristic).

The figure above represents a heavily loaded system using a maximum generation profile. The zone 2 mho circle (set at 137% of  $Z_L$ ) extends into the power swing stability boundary (i.e., the orange partial lens characteristic). Using the strongest source system is more conservative because it shrinks the power swing stability boundary, bringing it closer to the mho circle. This figure also graphically represents the effect of a system strengthening over time and this is the reason for re-evaluation if the relay has not been evaluated in the last three calendar years. Figure 9 below depicts a relay that meets the, PRC-026-1 – Attachment B, Criteria A. Figure 8 depicts the same relay with the same setting three years later, where each source has strengthened by about 10% and now the same zone 2 element does not meet Criteria A.



**Figure 9.** A weak-source system with a line impedance of  $Z_L = 20.4$  ohms (i.e., the thicker red line). This zone 2 element (i.e., the blue circle) meets the PRC-026-1 – Attachment B, Criteria A because it is completely contained within the power swing stability boundary (i.e., the orange lens characteristic).

The figure above represents a lightly loaded system, using a minimum generation profile. The zone 2 mho circle (set at 137% of  $Z_L$ ) does not extend into the power swing stability boundary (i.e., the orange lens characteristic). Using a weaker source system expands the power swing stability boundary away from the mho circle.



**Figure 10.** This is an example of a power swing stability boundary (i.e., the orange lens characteristic) with the transfer impedance removed. This relay zone 2 element (i.e., the blue circle) does not meet PRC-026-1 – Attachment B, Criteria A because it is not completely contained within the power swing stability boundary.

Table 8. Example Calculation (Transfer Impedance Removed)	
Calculations for the point at 120 degrees with equal source impedances. The total system current equals the line current. See Figure 10.	
Eq. (54)	$E_S = \frac{V_{LL} \angle 120^\circ}{\sqrt{3}}$
	$E_S = \frac{230,000 \angle 120^\circ V}{\sqrt{3}}$

## Application Guidelines

Table 8. Example Calculation (Transfer Impedance Removed)			
	$E_S = 132,791 \angle 120^\circ V$		
Eq. (55)	$E_R = \frac{V_{LL} \angle 0^\circ}{\sqrt{3}}$		
	$E_R = \frac{230,000 \angle 0^\circ V}{\sqrt{3}}$		
	$E_R = 132,791 \angle 0^\circ V$		
Given impedance data.			
Given:	$Z_S = 2 + j10 \Omega$	$Z_L = 4 + j20 \Omega$	$Z_R = 4 + j20 \Omega$
Given:	$Z_{TR} = Z_L \times 10^{10} \Omega$		
Total impedance between generators.			
Eq. (56)	$Z_{total} = \frac{(Z_L \times Z_{TR})}{(Z_L + Z_{TR})}$		
	$Z_{total} = \frac{((4 + j20) \Omega \times (4 + j20)^{10} \Omega)}{((4 + j20) \Omega + (4 + j20)^{10} \Omega)}$		
	$Z_{total} = 4 + j20 \Omega$		
Total system impedance.			
Eq. (57)	$Z_{sys} = Z_S + Z_{total} + Z_R$		
	$Z_{sys} = (2 + j10) \Omega + (4 + j20) \Omega + (4 + j20) \Omega$		
	$Z_{sys} = 10 + j50 \Omega$		
Total system current from sending source.			
Eq. (58)	$I_{sys} = \frac{E_S - E_R}{Z_{sys}}$		
	$I_{sys} = \frac{132,791 \angle 120^\circ V - 132,791 \angle 0^\circ V}{10 + j50 \Omega}$		
	$I_{sys} = 4,511 \angle 71.3^\circ A$		

## Application Guidelines

**Table 8. Example Calculation (Transfer Impedance Removed)**

The current as measured by the relay on  $Z_L$  is only the current flowing through that line as determined by using the current divider equation.

Eq. (59) 
$$I_L = I_{sys} \times \frac{Z_{TR}}{Z_L + Z_{TR}}$$

$$I_L = 4,511 \angle 71.3^\circ A \times \frac{(4 + j20)^{10} \Omega}{(4 + j20) \Omega + (4 + j20)^{10} \Omega}$$

$$I_L = 4,511 \angle 71.3^\circ A$$

The voltage as measured by the relay on  $Z_L$  is the voltage drop from the sending source through the sending source impedance.

Eq. (60) 
$$V_S = E_S - (Z_S \times I_{sys})$$

$$V_S = 132,791 \angle 120^\circ V - [(2 + j10 \Omega) \times 4,511 \angle 71.3^\circ A]$$

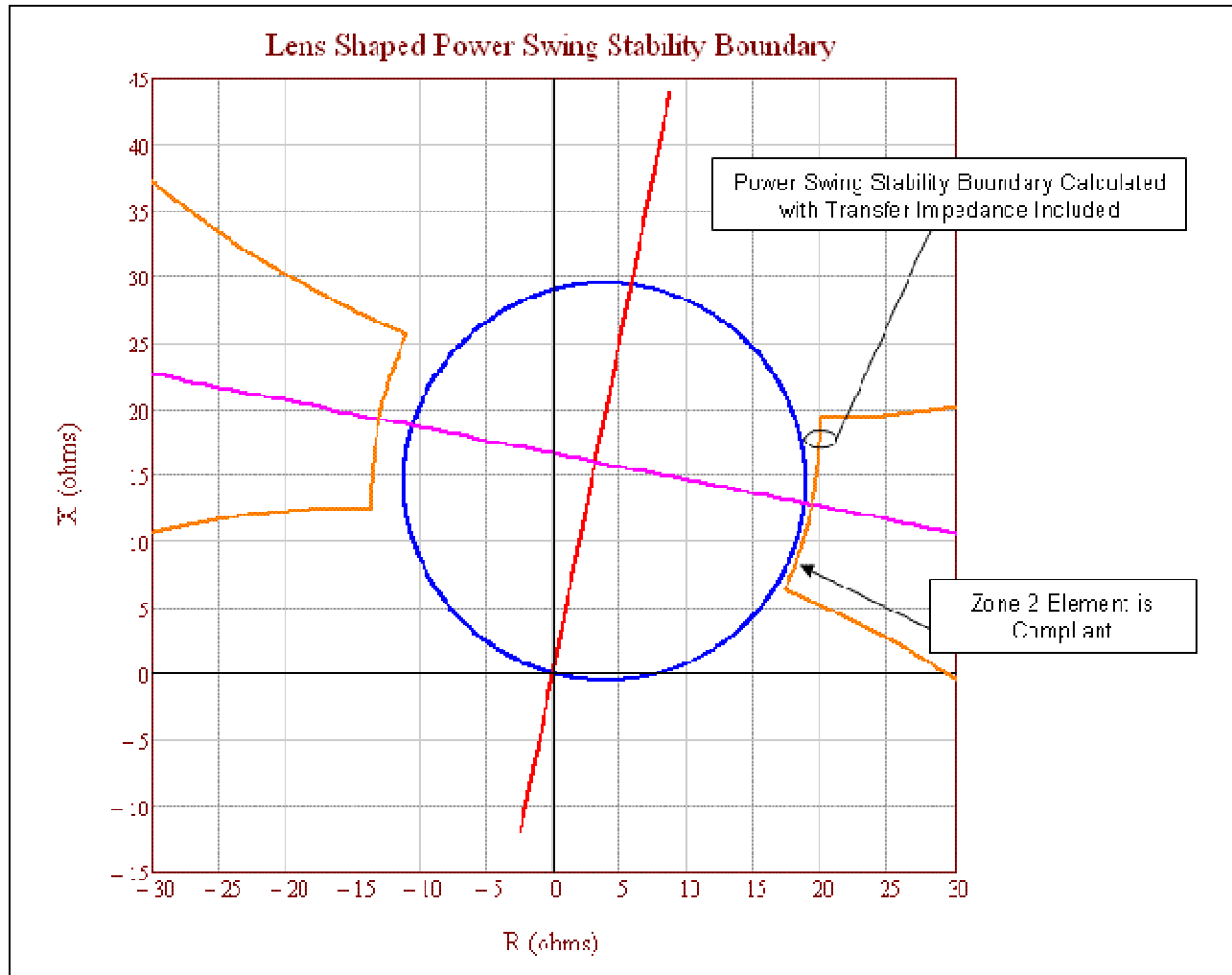
$$V_S = 95,757 \angle 106.1^\circ V$$

The impedance seen by the relay on  $Z_L$ .

Eq. (61) 
$$Z_{L-Relay} = \frac{V_S}{I_L}$$

$$Z_{L-Relay} = \frac{95,757 \angle 106.1^\circ V}{4,511 \angle 71.3^\circ A}$$

$$Z_{L-Relay} = 17.434 + j12.113 \Omega$$



**Figure 11.** This is an example of a power swing stability boundary (i.e., the orange lens characteristic) with the transfer impedance included. The zone 2 element (i.e., the blue circle) meets the PRC-026-1 – Attachment B, Criteria A because it is completely contained within the power swing stability boundary.

In the figure above, the transfer impedance is 5 times the line impedance. The lens characteristic has expanded out beyond the zone 2 element due to the infeed effect from the parallel current through the transfer impedance, thus allowing the zone 2 element to meet PRC-026-1 – Attachment B, Criteria A.

## Application Guidelines

**Table 9. Example Calculation (Transfer Impedance Included)**

Calculations for the point at 120 degrees with equal source impedances. The total system current does not equal the line current. See Figure 11.

Eq. (62)	$E_S = \frac{V_{LL} \angle 120^\circ}{\sqrt{3}}$		
	$E_S = \frac{230,000 \angle 120^\circ V}{\sqrt{3}}$		
	$E_S = 132,791 \angle 120^\circ V$		
Eq. (63)	$E_R = \frac{V_{LL} \angle 0^\circ}{\sqrt{3}}$		
	$E_R = \frac{230,000 \angle 0^\circ V}{\sqrt{3}}$		
	$E_R = 132,791 \angle 0^\circ V$		
Given impedance data.			
Given:	$Z_S = 2 + j10 \Omega$	$Z_L = 4 + j20 \Omega$	$Z_R = 4 + j20 \Omega$
Given:	$Z_{TR} = Z_L \times 5$		
	$Z_{TR} = (4 + j20) \Omega \times 5$		
	$Z_{TR} = 20 + j100 \Omega$		
Total impedance between generators.			
Eq. (64)	$Z_{total} = \frac{(Z_L \times Z_{TR})}{(Z_L + Z_{TR})}$		
	$Z_{total} = \frac{(4 + j20) \Omega \times (20 + j100) \Omega}{(4 + j20) \Omega + (20 + j100) \Omega}$		
	$Z_{total} = 3.333 + j16.667 \Omega$		
Total system impedance.			
Eq. (65)	$Z_{sys} = Z_S + Z_{total} + Z_R$		
	$Z_{sys} = (2 + j10) \Omega + (3.333 + j16.667) \Omega + (4 + j20) \Omega$		



## Application Guidelines

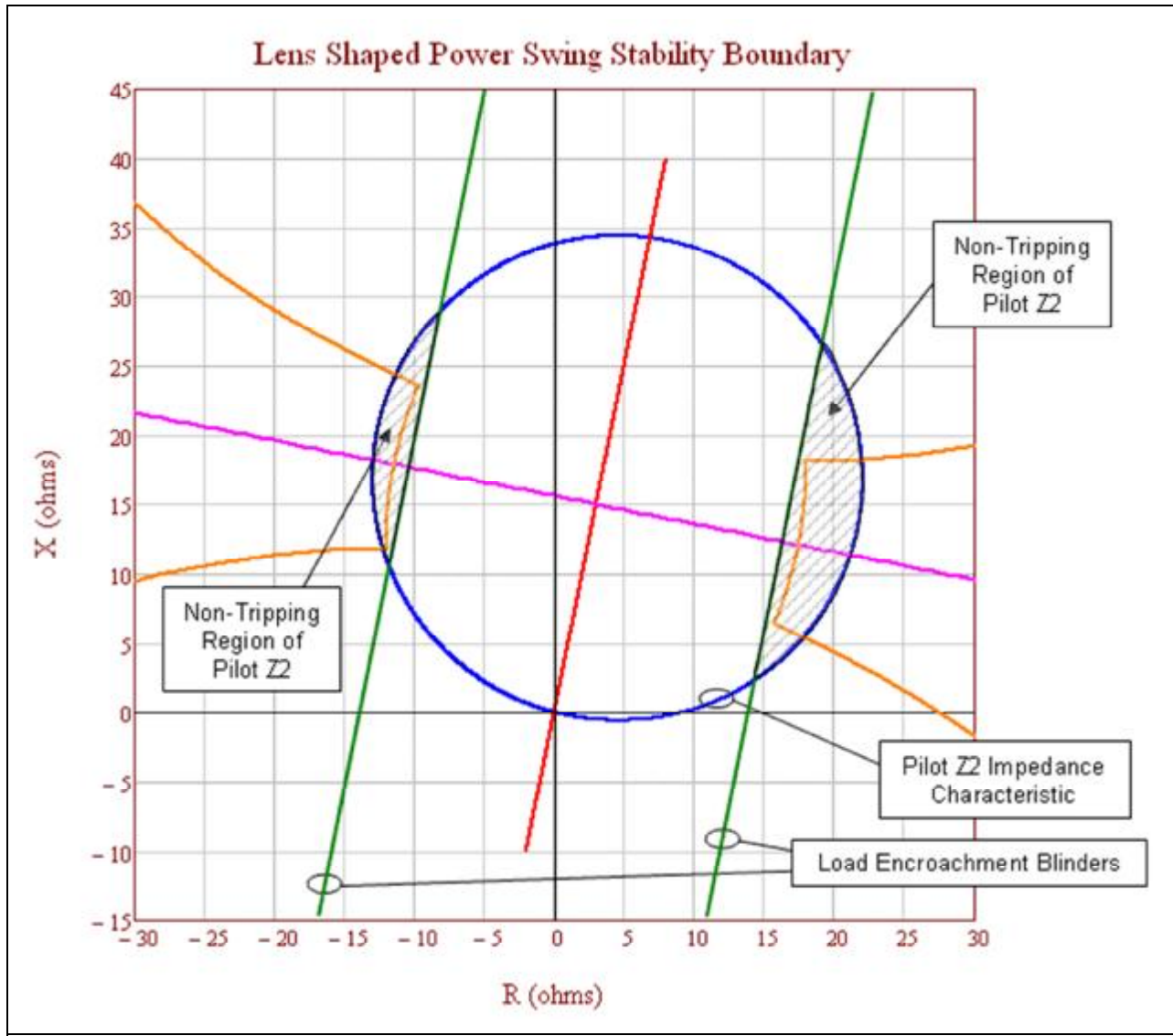
Table 9. Example Calculation (Transfer Impedance Included)	
	$Z_{sys} = 9.333 + j46.667 \Omega$
Total system current from sending source.	
Eq. (66)	$I_{sys} = \frac{E_S - E_R}{Z_{sys}}$
	$I_{sys} = \frac{132,791 \angle 120^\circ V - 132,791 \angle 0^\circ V}{9.333 + j46.667 \Omega}$
	$I_{sys} = 4,832 \angle 71.3^\circ A$
The current as measured by the relay on $Z_L$ is only the current flowing through that line as determined by using the current divider equation.	
Eq. (67)	$I_L = I_{sys} \times \frac{Z_{TR}}{Z_L + Z_{TR}}$
	$I_L = 4,832 \angle 71.3^\circ A \times \frac{(20 + j100) \Omega}{(9.333 + j46.667) \Omega + (20 + j100) \Omega}$
	$I_L = 4,027.4 \angle 71.3^\circ A$
The voltage as measured by the relay on $Z_L$ is the voltage drop from the sending source through the sending source impedance.	
Eq. (68)	$V_S = E_S - (Z_S \times I_{sys})$
	$V_S = 132,791 \angle 120^\circ V - [(2 + j10 \Omega) \times 4,027 \angle 71.3^\circ A]$
	$V_S = 93,417 \angle 104.7^\circ V$
The impedance seen by the relay on $Z_L$ .	
Eq. (69)	$Z_{L-Relay} = \frac{V_S}{I_L}$
	$Z_{L-Relay} = \frac{93,417 \angle 104.7^\circ V}{4,027 \angle 71.3^\circ A}$
	$Z_{L-Relay} = 19.366 + j12.767 \Omega$

## Application Guidelines

**Table 10. Percent Increase of a Lens Due To Parallel Transfer Impedance.**

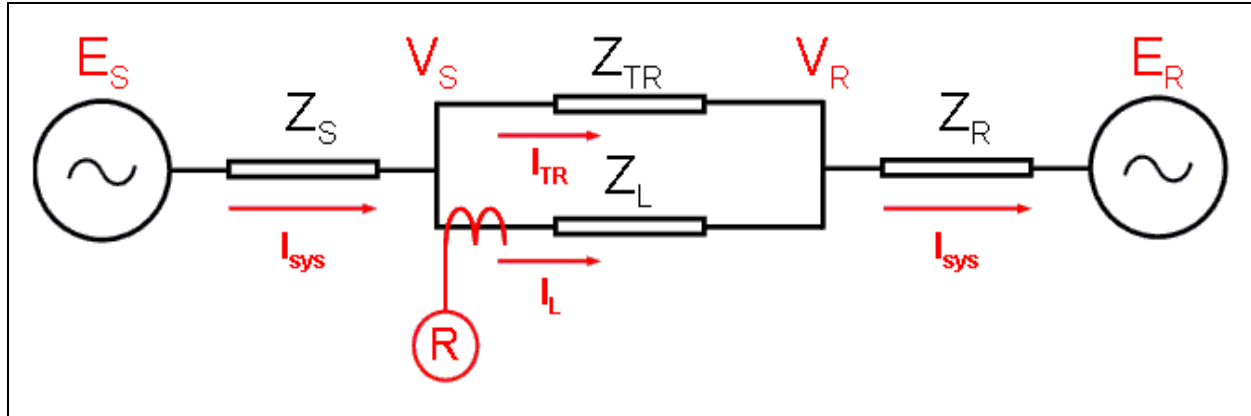
The following demonstrates the percent size increase of the lens characteristic for  $Z_{TR}$  in multiples of  $Z_L$  with the transfer impedance included.

$Z_{TR}$ in multiples of $Z_L$	Percent increase of lens with equal EMF sources (Infinite source as reference)
Infinite	N/A
1000	0.05%
100	0.46%
10	4.63%
5	9.27%
2	23.26%
1	46.76%
0.5	94.14%
0.25	189.56%



**Figure 12.** The tripping portion not blocked by load encroachment (i.e., the parallel green lines) of the pilot zone 2 element (i.e., the blue circle) is completely contained within the power swing stability boundary (i.e., the orange lens characteristic). Therefore, the zone 2 element meets the PRC-026-1 – Attachment B, Criteria A.

## Application Guidelines



**Figure 13:** The infeed diagram shows the impedance in front of the relay R with the parallel transfer impedance included. As the parallel transfer impedance approaches infinity, the impedances seen by the relay R in the forward direction becomes  $Z_L + Z_R$ .

**Table 11. Calculations (System Apparent Impedance in the forward direction)**

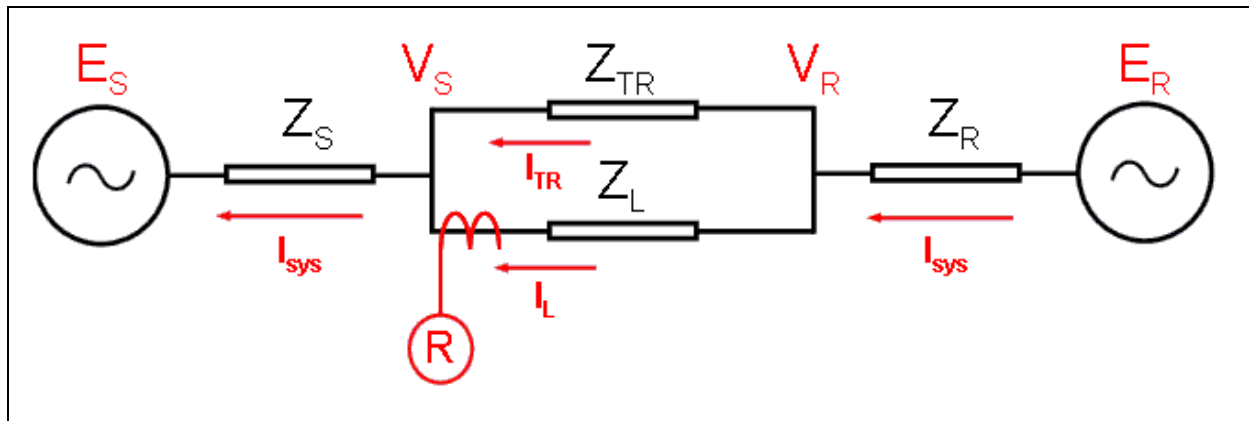
The following equations are provided for calculating the apparent impedance back to the  $E_R$  source voltage as seen by relay R. Infeed equations from  $V_S$  to source  $E_R$  where  $E_R = 0$ . See Figure 13.

Eq. (70)	$I_L = \frac{V_S - V_R}{Z_L}$			
Eq. (71)	$I_{sys} = \frac{V_R - E_R}{Z_R}$			
Eq. (72)	$I_{sys} = I_L + I_{TR}$			
Eq. (73)	$I_{sys} = \frac{V_R}{Z_R}$	Since $E_R = 0$	Rearranged:	$V_R = I_{sys} \times Z_R$
Eq. (74)	$I_L = \frac{V_S - I_{sys} \times Z_R}{Z_L}$			
Eq. (75)	$I_L = \frac{V_S - [(I_L + I_{TR}) \times Z_R]}{Z_L}$			
Eq. (76)	$V_S = (I_L \times Z_L) + (I_L \times Z_R) + (I_{TR} \times Z_R)$			
Eq. (77)	$Z_{Relay} = \frac{V_S}{I_L} = Z_L + Z_R + \frac{I_{TR} \times Z_R}{I_L} = Z_L + Z_R \times \left(1 + \frac{I_{TR}}{I_L}\right)$			

## Application Guidelines

**Table 11. Calculations (System Apparent Impedance in the forward direction)**

Eq. (78)	$I_{TR} = I_{sys} \times \frac{Z_L}{Z_L + Z_{TR}}$
Eq. (79)	$I_L = I_{sys} \times \frac{Z_{TR}}{Z_L + Z_{TR}}$
Eq. (80)	$\frac{I_{TR}}{I_L} = \frac{Z_L}{Z_{TR}}$
The infeed equations shows the impedance in front of the relay R with the parallel transfer impedance included. As the parallel transfer impedance approaches infinity, the impedances seen by the relay R in the forward direction becomes $Z_L + Z_R$ .	
Eq. (81)	$Z_{Relay} = Z_L + Z_R \times \left(1 + \frac{Z_L}{Z_{TR}}\right)$



**Figure 14:** The infeed diagram shows the impedance behind relay R with the parallel transfer impedance included. As the parallel transfer impedance approaches infinity, the impedances seen by the relay R in the reverse direction becomes  $Z_S$ .

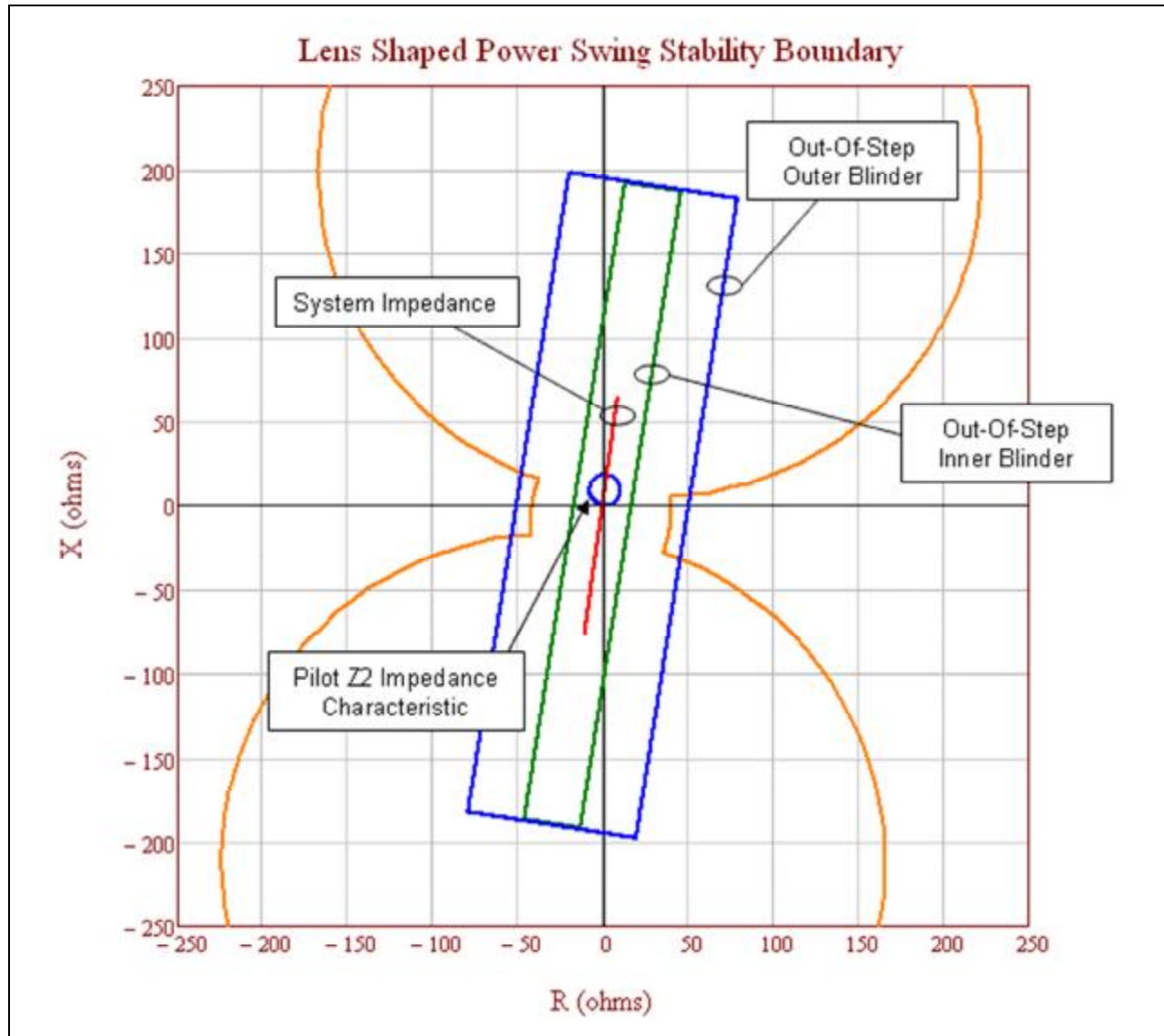
**Table 12. Calculations (System Apparent Impedance in the reverse direction)**

The following equations are provided for calculating the apparent impedance back to the  $E_S$  source voltage as seen by relay R. Infeed equations from  $V_R$  back to source  $E_S$  where  $E_S = 0$ . See Figure 14.

Eq. (82)	$I_L = \frac{V_R - V_S}{Z_L}$
----------	-------------------------------

## Application Guidelines

Table 12. Calculations (System Apparent Impedance in the reverse direction)				
Eq. (83)	$I_{sys} = \frac{V_S - E_S}{Z_S}$			
Eq. (84)	$I_{sys} = I_L + I_{TR}$			
Eq. (85)	$I_{sys} = \frac{V_S}{Z_S}$	Since $E_S = 0$	Rearranged:	$V_S = I_{sys} \times Z_S$
Eq. (86)	$I_L = \frac{V_R - I_{sys} \times Z_S}{Z_L}$			
Eq. (87)	$I_L = \frac{V_R - [(I_L + I_{TR}) \times Z_S]}{Z_L}$			
Eq. (88)	$V_R = (I_L \times Z_L) + (I_L \times Z_S) + (I_{TR} \times Z_{RS})$			
Eq. (89)	$Z_{Relay} = \frac{V_R}{I_L} = Z_L + Z_S + \frac{I_{TR} \times Z_S}{I_L} = Z_L + Z_S \times \left(1 + \frac{I_{TR}}{I_L}\right)$			
Eq. (90)	$I_{TR} = I_{sys} \times \frac{Z_L}{Z_L + Z_{TR}}$			
Eq. (91)	$I_L = I_{sys} \times \frac{Z_{TR}}{Z_L + Z_{TR}}$			
Eq. (92)	$\frac{I_{TR}}{I_L} = \frac{Z_L}{Z_{TR}}$			
The infeed equations shows the impedance behind relay R with the parallel transfer impedance included. As the parallel transfer impedance approaches infinity, the impedances seen by the relay R in the reverse direction becomes $Z_S$ .				
Eq. (93)	$Z_{Relay} = Z_L + Z_S \times \left(1 + \frac{Z_L}{Z_{TR}}\right)$	As seen by relay R at the receiving-end of the line.		
Eq. (94)	$Z_{Relay} = Z_S \times \left(1 + \frac{Z_L}{Z_{TR}}\right)$	Subtract $Z_L$ for relay R impedance as seen at sending-end of the line.		



**Figure 15.** Out-of-step trip (OST) inner blinder (i.e., the parallel green lines) meets the PRC-026-1 – Attachment B, Criteria A because the inner OST blinder initiates tripping either On-The-Way-In or On-The-Way-Out. Since the inner blinder is completely contained within the portion of the power swing stability boundary (i.e., the orange lens characteristic), the zone 2 element (i.e., the blue circle) meets the PRC-026-1 – Attachment B, Criteria A.

**Table 13. Example Calculation (Voltage Ratios)**

These calculations are based on the loss of synchronism characteristics for the cases of  $N < 1$  and  $N > 1$  as found in the *Application of Out-of-Step Blocking and Tripping Relays*, GER-3180, p. 12, Figure 3.<sup>11</sup> The GE illustration shows the formulae used to calculate the radius and center of the circles that make up the ends of the portion of the lens.

Voltage ratio equations, source impedance equation with infeed formulae applied, and circle equations.

Given:	$E_S = 0.7$	$E_R = 1.0$	
Eq. (95)	$N_a = \frac{ E_S }{ E_R } = \frac{0.7}{1.0} = 0.7$		
Eq. (96)	$N_b = \frac{ E_R }{ E_S } = \frac{1.0}{0.7} = 1.43$		
The total system impedance as seen by the relay with infeed formulae applied.			
Given:	$Z_S = 2 + j10 \Omega$	$Z_L = 4 + j20 \Omega$	$Z_R = 4 + j20 \Omega$
Given:	$Z_{TR} = Z_L \times 10^{10} \Omega$		
	$Z_{TR} = (4 + j20)^{10} \Omega$		
Eq. (97)	$Z_{sys} = Z_S \times \left(1 + \frac{Z_L}{Z_{TR}}\right) + \left[Z_L + Z_R \times \left(1 + \frac{Z_L}{Z_{TR}}\right)\right]$		
	$Z_{sys} = 10 + j50 \Omega$		
The calculated coordinates of the lower circle center.			
Eq. (98)	$Z_{C1} = - \left[ Z_S \times \left(1 + \frac{Z_L}{Z_{TR}}\right) \right] - \left[ \frac{N_a^2 \times Z_{sys}}{1 - N_a^2} \right]$		
	$Z_{C1} = - \left[ (2 + j10) \Omega \times \left(1 + \frac{(4 + j20) \Omega}{(4 + j20)^{10} \Omega}\right) \right] - \left[ \frac{0.7^2 \times (10 + j50) \Omega}{1 - 0.7^2} \right]$		
	$Z_{C1} = -11.608 - j58.039 \Omega$		

<sup>11</sup> <http://store.gedigitalenergy.com/faq/Documents/Alps/GER-3180.pdf>



## Application Guidelines

**Table 13. Example Calculation (Voltage Ratios)**

The calculated radius of the lower circle.	
Eq. (99)	$r_a = \left[ \frac{N_a \times Z_{sys}}{1 - N_a^2} \right]$
	$r_a = \left[ \frac{0.7 \times (10 + j50) \Omega}{1 - 0.7^2} \right]$
	$r_a = 69.987 \Omega$
The calculated coordinates of the upper circle center.	
Eq. (100)	$Z_{C2} = Z_L + \left[ Z_R \times \left( 1 + \frac{Z_L}{Z_{TR}} \right) \right] + \left[ \frac{Z_{sys}}{N_b^2 - 1} \right]$
	$Z_{C2} = - \left[ (4 + j20) \Omega \times \left( 1 + \frac{(4 + j20) \Omega}{(4 + j20)^{10} \Omega} \right) \right] + \left[ \frac{(10 + j50) \Omega}{1.43^2 - 1} \right]$
	$Z_{C2} = 17.608 + j88.039 \Omega$
The calculated radius of the upper circle.	
Eq. (101)	$r_b = \left[ \frac{N_b \times Z_{sys}}{N_b^2 - 1} \right]$
	$r_b = \left[ \frac{1.43 \times (10 + j50) \Omega}{1.43^2 - 1} \right]$
	$r_b = 69.987 \Omega$

### Application Specific to Criteria B

The PRC-026-1 – Attachment B, Criteria B evaluates overcurrent elements used for tripping. The same criteria as PRC-026-1 – Attachment B, Criteria A is used except for an additional criteria (No. 4) that calculates a current magnitude based upon generator terminal voltages of 1.05 per unit. The formula used to calculate the current is as follows:

**Table 14. Example Calculation (Overcurrent)**

This example is for a 230 kV line terminal with a directional instantaneous phase overcurrent element set to 50 amps secondary times a CT ratio of 160:1 that equals 8000 amps on the primary. The following calculation is where  $V_S$  equals the base line-to-ground sending-end generator source voltage times 1.05 at an angle of 120 degrees,  $V_R$  equals the base line-to-ground receiving-end generator terminal voltage times 1.05 at an angle of 0 degrees, and  $Z_{sys}$  equals the sum of the sending-end, line, and receiving-end source impedances in ohms.

Eq. (102)	$V_S = \frac{V_{LL} \angle 120^\circ}{\sqrt{3}} \times 1.05$		
	$V_S = \frac{230,000 \angle 120^\circ V}{\sqrt{3}} \times 1.05$		
	$V_S = 139,430 \angle 120^\circ V$		
Receiving-end generator terminal voltage.			
Eq. (103)	$V_R = \frac{V_{LL} \angle 0^\circ}{\sqrt{3}} \times 1.05$		
	$V_R = \frac{230,000 \angle 0^\circ V}{\sqrt{3}} \times 1.05$		
	$V_R = 139,430 \angle 0^\circ V$		
The total impedance of the system ( $Z_{sys}$ ) equals the sum of the sending-end source impedance ( $Z_S$ ), the impedance of the line ( $Z_L$ ), and receiving-end impedance ( $Z_R$ ) in ohms.			
Given:	$Z_S = 3 + j26 \Omega$	$Z_L = 1.3 + j8.7 \Omega$	$Z_R = 0.3 + j7.3 \Omega$
Eq. (104)	$Z_{sys} = Z_S + Z_L + Z_R$		
	$Z_{sys} = (3 + j26) \Omega + (1.3 + j8.7) \Omega + (0.3 + j7.3) \Omega$		
	$Z_{sys} = 4.6 + j42 \Omega$		
Total system current from sending source.			
Eq. (105)	$I_{sys} = \frac{(V_S - V_R)}{Z_{sys}}$		
	$I_{sys} = \frac{(139,430 \angle 120^\circ V - 139,430 \angle 0^\circ V)}{(4.6 + j42) \Omega}$		

**Table 14. Example Calculation (Overcurrent)**

$$I_{sys} = 5,715.82 \angle 66.25^\circ A$$

This example is for a 230 kV line terminal with a directional instantaneous phase overcurrent element set to 50 amps-secondary times a CT ratio of 160:1 that equals 8,000 amps-primary. Here, the phase instantaneous setting of 8,000 amps is greater than the calculated system current of 5,716 amps, therefore it is compliant with PRC-026-1 – Attachment B, Criteria B.

### Application to Generation Elements

As with Transmission Elements, the determination of the apparent impedance seen at an Element located at, or near, a generation Facility is complex for power swings due to various interdependent quantities. These variances in quantities are caused by changes in machine internal voltage, speed governor action, voltage regulator action, the reaction of other local generators, and the reaction of other interconnected transmission Elements as the event progresses through the time domain. Though transient stability simulations may be used to determine the apparent impedance for verifying load-responsive relay settings,<sup>12,13</sup> Requirement R4, PRC-026-1 – Attachment B, Criteria A and B provides a simplified method for evaluating the load-responsive protective relay's susceptibility to tripping in response to a stable power swing without requiring stability simulations.

In general, the electrical center will be in the transmission system for cases where the generator is connected through a weak transmission system (high external impedance). Other cases where the generator is connected through a strong transmission system, the electrical center could be inside the unit connected zone.<sup>14</sup> In either case, load-responsive protective relays connected at the generator terminals or at the high-voltage side of the generator step-up (GSU) transformer may be challenged by power swings as determined by the Planning Coordinator in Requirement R1 or a power swing event documented by an actual Disturbance in Requirement R2 and R3.

Load-responsive protective relays such as time over-current, voltage controlled time-overcurrent or voltage-restrained time-overcurrent relays are excluded from this standard since they are set based on equipment permissible overload capability. Their operating time is much greater than 15 cycles for the current levels observed during a power swing.

Instantaneous overcurrent and definite-time overcurrent relays with a time delay of less than 15 cycles are included and are required to be evaluated.

The generator loss-of-field protective function is provided by impedance relay(s) connected at the generator terminals. The settings are applied to protect the generator from a partial or

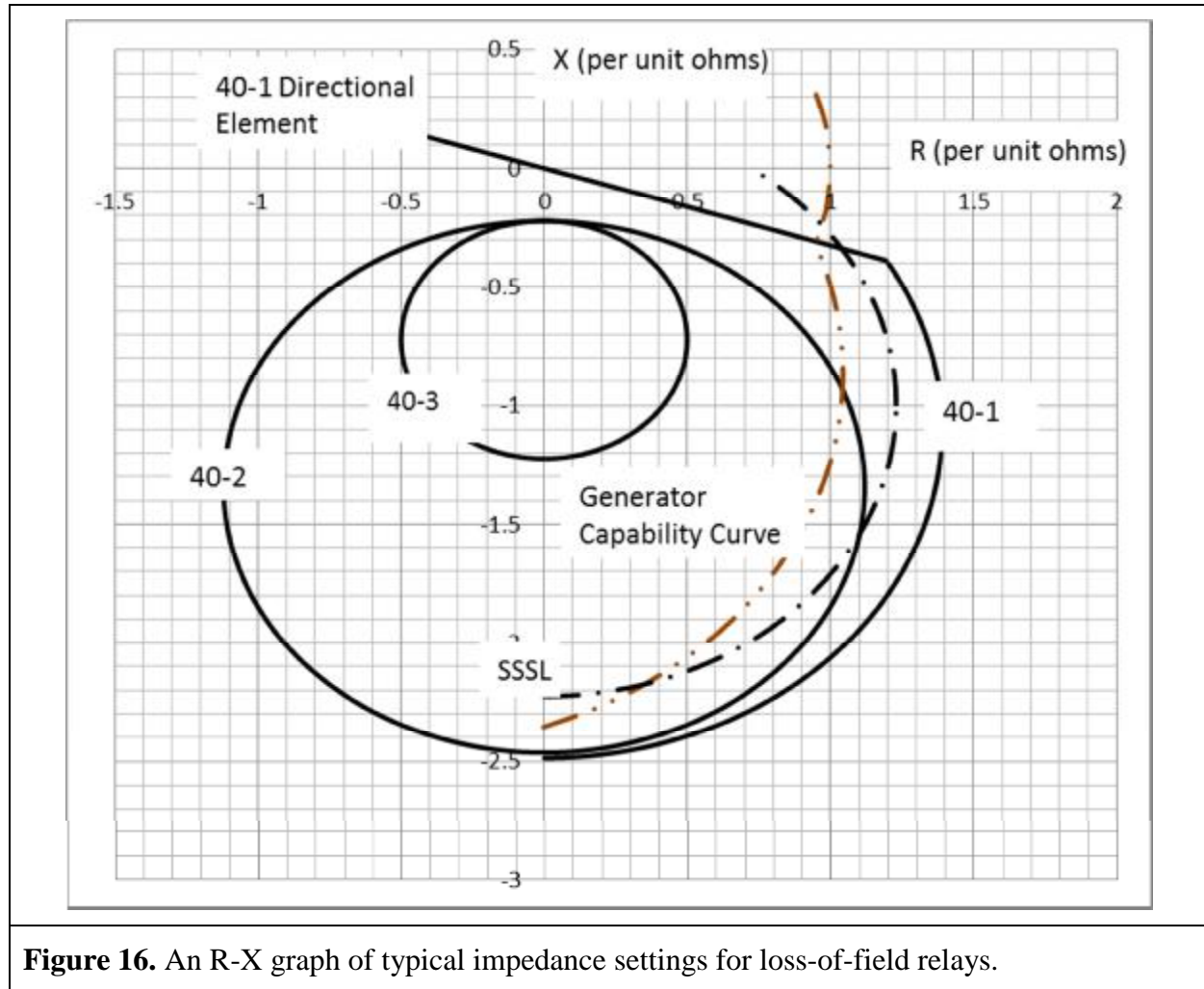
<sup>12</sup> Donald Reimert, *Protective Relaying for Power Generation Systems*, Boca Raton, FL, CRC Press, 2006.

<sup>13</sup> Prabha Kundar, *Power System Stability and Control*, EPRI, McGraw Hill, Inc., 1994.

<sup>14</sup> Ibid, Kundar.

## Application Guidelines

complete loss of excitation under all generator loading conditions and, at the same time, be immune to tripping on stable power swings. It is more likely that the relay would operate during a power swing when the automatic voltage regulator (AVR) is in manual mode rather than when in automatic mode.<sup>15</sup> Figure 16 illustrates in the R-X plot, the loss-of-field relays typically include up to three zones of protection.



**Figure 16.** An R-X graph of typical impedance settings for loss-of-field relays.

Loss-of-field characteristic 40-1 has a wider impedance characteristic (positive offset) than characteristic 40-2 or characteristic 40-3 and provides additional generator protection for a partial loss of field or a loss of field under low load (less than 10% of rated). The tripping logic of this protection scheme is established by a directional contact, a voltage setpoint, and a time delay. The voltage and time delay add security to the relay operation for stable power swings. Characteristic 40-3 is less sensitive to power swings than characteristic 40-2 and is set outside the generator capability curve in the leading direction. Regardless of the relay impedance setting,

<sup>15</sup> John Burdy, *Loss-of-excitation Protection for Synchronous Generators GER-3183*, General Electric Company.

## Application Guidelines

---

PRC-019 requires that the “in-service limiters operate before Protection Systems to avoid unnecessary trip” and “in-service Protection System devices are set to isolate or de-energize equipment in order to limit the extent of damage when operating conditions exceed equipment capabilities or stability limits.” Time delays for tripping associated with loss-of-field relays<sup>16,17</sup> have a range from 15 cycles for characteristic 40-2 to 60 cycles for characteristic 40-1 to minimize tripping during stable power swings. In the standard, 15 cycles establishes a threshold for applicability; however, it is the responsibility of the Generator Owner to establish settings that provide security against stable power swings and, at the same time, dependable protection for the generator.

The simple two-machine system circuit (method also used in Transmission Element section) is used to analyze the effect of a power swing at a generator facility for load-responsive relays pursuant to Requirement R4. In this section, the calculation method is used for calculating the impedance seen by the relay connected at a point in the circuit.<sup>18</sup> The electrical quantities used to determine the apparent impedance plot using this method are generator saturated transient reactance ( $X'_d$ ), GSU transformer impedance ( $X_{GSU}$ ), transmission line impedance ( $Z_L$ ), and the system equivalent ( $Z_e$ ) at the point of interconnection. All impedance values are known to the Generator Owner except for the system equivalent. The system equivalent is available from the Transmission Owner. The sending- and receiving-end source voltages are varied from 0.7 to 1.0 per unit to form a portion of a lens characteristic instead of varying the voltages from 0 to 1.0 per unit which would form a full lens characteristic. The voltage range of 0.7 – 1.0 results in a ratio range from 0.7 to 1.43. This ratio range is used in determining the portion of the lens. A system separation angle of 120 degrees is also used in each load-responsive protective relay evaluation.

Below is an example calculation of the apparent impedance locus method based on Figures 18 and 19.<sup>19</sup> In this example, the generator is connected to the 345 kV transmission system through the GSU transformer and has the ratings listed. The load-responsive protective relay responsibilities below are divided between the Generator Owner and Transmission Owner.

---

<sup>16</sup> Ibid, Burdy.

<sup>17</sup> *Applied Protective Relaying*, Westinghouse Electric Corporation, 1979.

<sup>18</sup> Edward Wilson Kimbark, *Power System Stability, Volume II: Power Circuit Breakers and Protective Relays*, Published by John Wiley and Sons, 1950.

<sup>19</sup> Ibid, Kimbark.

## Application Guidelines

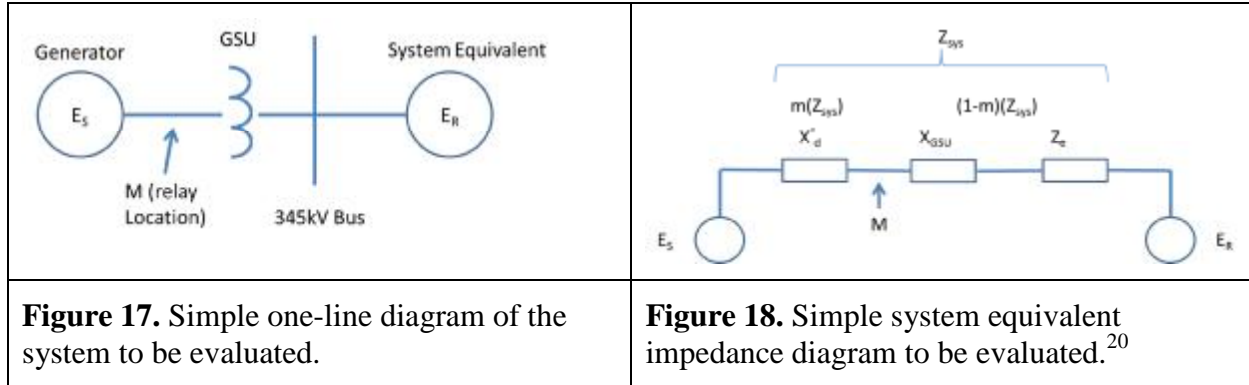


Table15. Example Data (Generator)	
Input Descriptions	Input Values
Synchronous Generator nameplate (MVA)	<b>940 MVA</b>
Sub-transient reactance (940MVA base – per unit)	<b>X'd = 0.3845</b>
Generator rated voltage (Line-to-Line)	<b>20 kV</b>
Generator step-up (GSU) transformer rating	<b>880 MVA</b>
GSU transformer reactance (880 MVA base)	<b>X<sub>GSU</sub> = 16.05%</b>
System Equivalent (100 MVA base)	<b>Z<sub>e</sub> = 0.00723∠86° ohms</b>
Generator Owner Load-Responsive Protective Relays	
40-1	<b>Positive Offset Impedance</b>
	<b>Offset = 0.294 per unit ohms</b>
	<b>Diameter = 0.294 per unit ohms</b>
40-2	<b>Negative Offset Impedance</b>
	<b>Offset = 0.22 per unit ohms</b>
	<b>Diameter = 2.24 per unit ohms</b>

<sup>20</sup> Ibid, Kimbark.

## Application Guidelines

Table15. Example Data (Generator)	
40-3	Negative Offset Impedance
	Offset = 0.22 per unit ohms
	Diameter = 1.00 per unit ohms
21-1	Diameter = 0.643 per unit ohms
	MTA = 85°
50	I (pickup) = 5.0 per unit
Transmission Owned Load-Responsive Protective Relays	
21-2	Diameter = 0.55 per unit ohms
	MTA = 85°

Calculations shown for a 120 degree angle and  $E_S/E_R = 1$ . The equation for calculating  $Z_R$  is:<sup>21</sup>

$$\text{Eq. (106)} \quad Z_R = \left( \frac{(1 - m)(E_S \angle \delta) + (m)(E_R)}{E_S \angle \delta - E_R} \right) \times Z_{sys}$$

Where  $m$  is the relay location as a function of the total impedance (real number less than 1)

$E_S$  and  $E_R$  is the sending- and receiving-end voltages

$Z_{sys}$  is the total system impedance

$Z_R$  is the complex impedance at the relay location and plotted on an R-X diagram

All of the above are constants (940 MVA base) while the angle  $\delta$  is varied. Table 16 below contains calculations for a generator using the data listed in Table 15.

Table16. Example Calculations (Generator)			
Given:	$X_d'' = j0.3845 \Omega$	$X_{GSU} = j0.171 \Omega$	$Z_e = 0.06796 \Omega$
Eq. (107)	$Z_{sys} = X_d'' + X_{GSU} + Z_e$		

<sup>21</sup> Ibid, Kimbark.

## Application Guidelines

Table 16. Example Calculations (Generator)	
	$Z_{sys} = j0.3845 \Omega + j0.171 \Omega + 0.06796 \Omega$
	$Z_{sys} = 0.6239 \angle 90^\circ \Omega$
Eq. (108)	$m = \frac{X_d''}{Z_{sys}} = \frac{0.3845}{0.6239} = 0.61633$
Eq. (109)	$Z_R = \left( \frac{(1 - m)(E_S \angle \delta) + (m)(E_R)}{E_S \angle \delta - E_R} \right) \times Z_{sys}$
	$Z_R = \left( \frac{(1 - 0.61633) \times (1 \angle 120^\circ) + (0.61633)(1 \angle 0^\circ)}{1 \angle 120^\circ - 1 \angle 0^\circ} \right) \times (0.6234 \angle 90^\circ) \Omega$
	$Z_R = \left( \frac{0.4244 + j0.3323}{-1.5 + j 0.866} \right) \times (0.6234 \angle 90^\circ) \Omega$
	$Z_R = (0.3112 \angle -111.94^\circ) \times (0.6234 \angle 90^\circ) \Omega$
	$Z_R = 0.194 \angle -21.94^\circ \Omega$
	$Z_R = -0.18 - j0.073 \Omega$

Table 17 lists the swing impedance values at other angles and at  $E_S/E_R = 1, 1.43,$  and  $0.7$ . The impedance values are plotted on an R-X graph with the center being at the generator terminals for use in evaluating impedance relay settings.



## Application Guidelines

**Table 17:** Sample calculations for a swing impedance chart for varying voltages at the sending- and receiving-end.

Angle ( $\delta$ ) (Degrees)	$E_S/E_R=1$		$E_S/E_R=1.43$		$E_S/E_R=0.7$	
	$Z_R$		$Z_R$		$Z_R$	
	Magnitude (PU Ohms)	Angle (Degrees)	Magnitude (PU Ohms)	Angle (Degrees)	Magnitude (PU Ohms)	Angle (Degrees)
90	0.320	-13.1	0.296	6.3	0.344	-31.5
120	0.194	-21.9	0.173	-0.4	0.227	-40.1
150	0.111	-41.0	0.082	-10.3	0.154	-58.4
210	0.111	-25.9	0.082	190.3	0.154	238.4
240	0.111	221.0	0.173	180.4	0.225	220.1
270	0.320	193.1	0.296	173.7	0.344	211.5

### Requirement R4 Generator Examples

#### *Distance Relay Application*

Based on PRC-026-1 – Attachment B, Criteria A, the distance relay (21-1) (owned by the generation entity) characteristic is in the region where a stable power swing would not occur as shown in Figure 19. There is no further obligation to the owner in this standard for this load-responsive protective relay.

The distance relay (21-2) (owned by the transmission entity) is connected at the high-voltage side of the GSU transformer and its impedance characteristic is in the region where a stable power swing could occur causing the relay to operate. In this example, if the intentional time delay of this relay is less than 15 cycles, the Transmission Owner is required to create a CAP (Requirement R5) to meet PRC-026 – Attachment B, Criteria B. Some of the options include, but are not limited to, changing the relay setting (i.e. impedance reach, angle, time delay), modify the scheme (i.e. add power swing blocking), or replace the Protection System. Note that the relay may be excluded from this standard if it has an intentional time delay equal to or greater than 15 cycles.

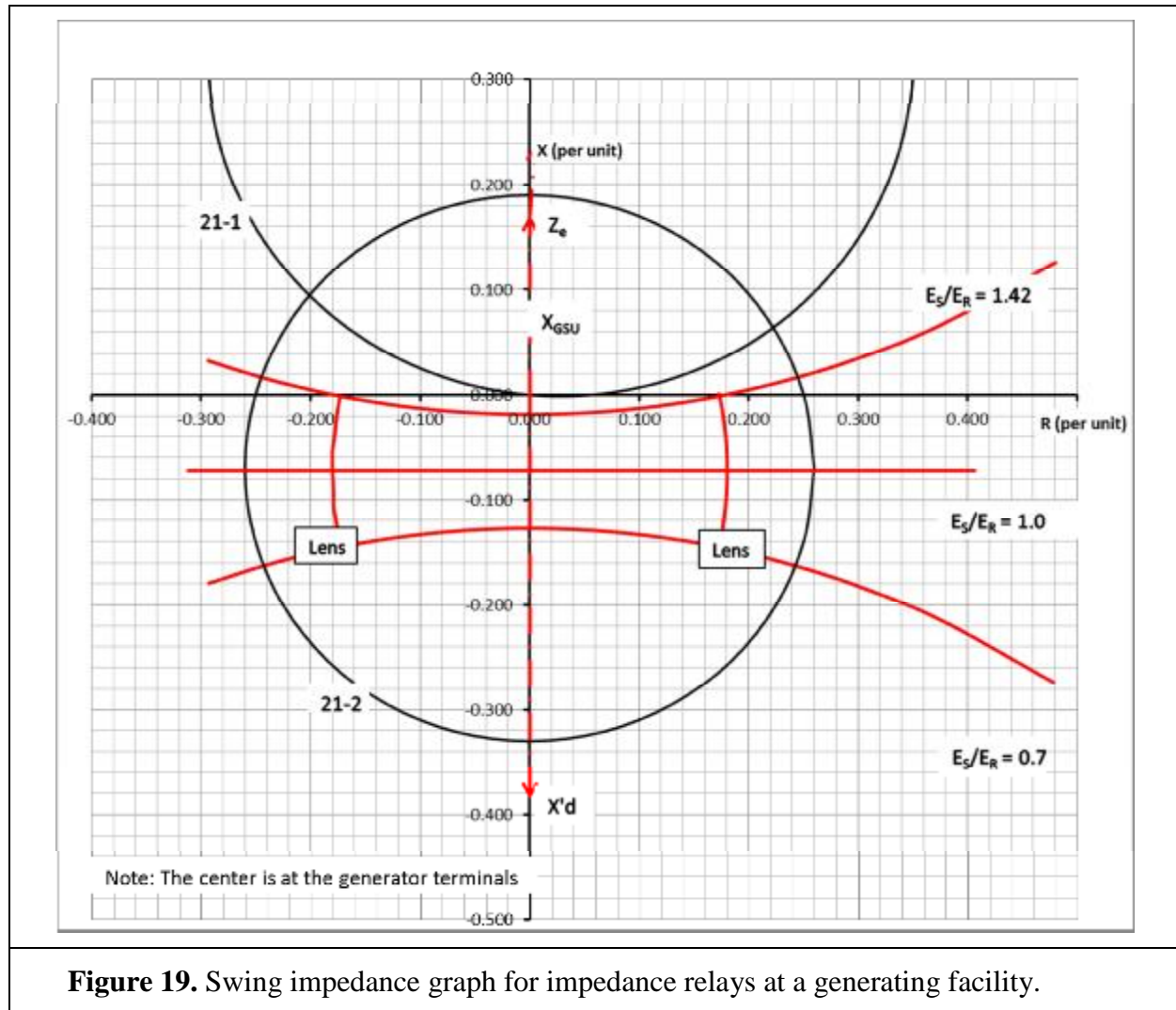
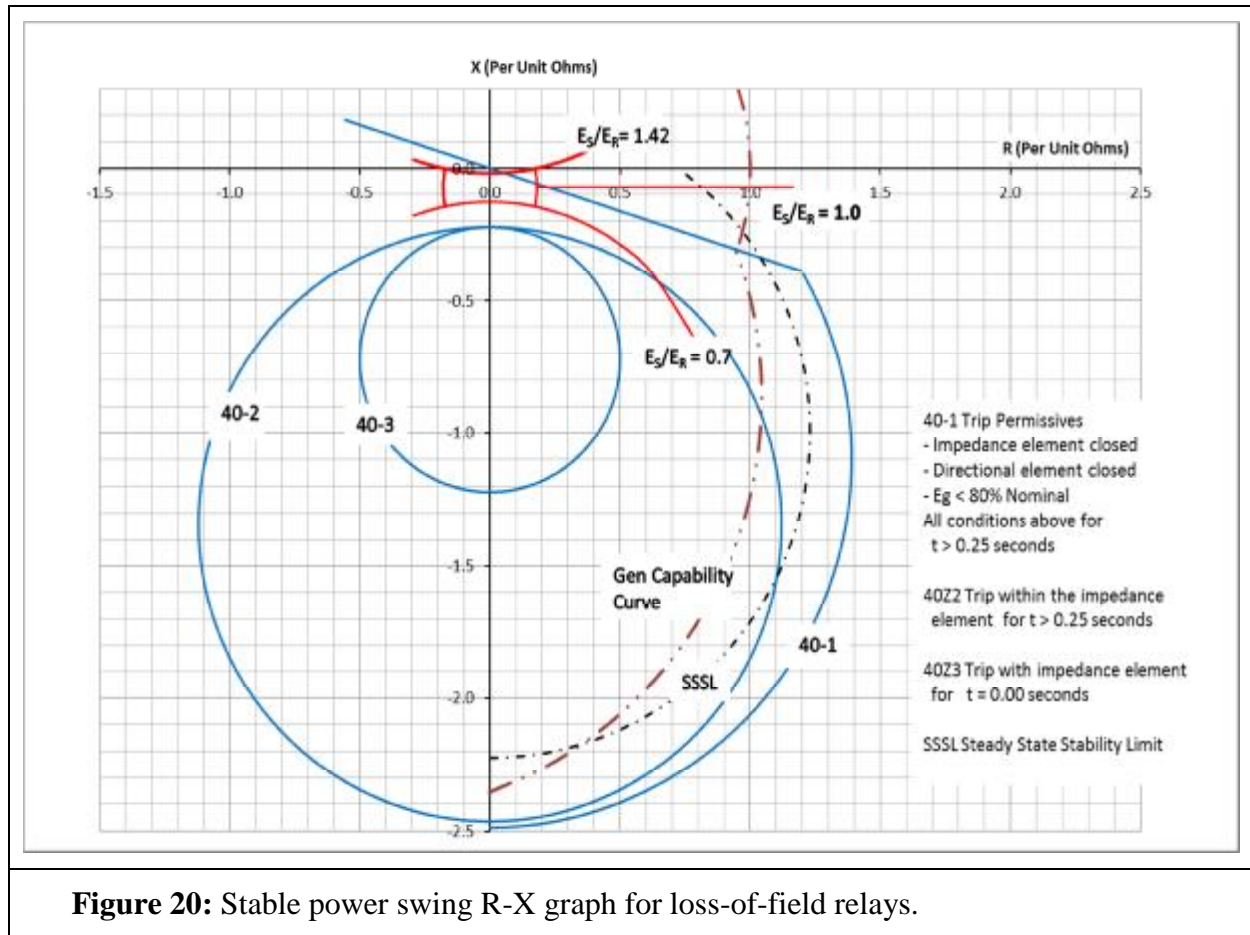


Figure 19. Swing impedance graph for impedance relays at a generating facility.

### Loss-of-Field Relay Application

In Figure 20, the R-X diagram shows the loss-of-field relay (40-1 and 40-2) characteristics are in the region where a stable power swing can cause a relay operation. Protective relay 40-1 would be excluded if it has an intentional time delay equal to or greater than 15 cycles. Similarly, 40-2 would be excluded if its intentional time delay is equal to or greater than 15 cycles. For example, if 40-1 has a time delay of 1 second and 40-2 has a time delay of 0.25 seconds, they are excluded and there is no further obligation to the owner in this standard for these relays. The loss-of-field relay characteristic 40-3 is outside the region where a stable power swing can cause a relay operation. In this case, the owner may select high speed tripping on operation of the 40-3 impedance element.



### Instantaneous Overcurrent Relay

In similar fashion to the transmission overcurrent example calculation in Table 14, the instantaneous overcurrent relay minimum setting is established by PRC-026-1 – Attachment B, Criteria B. The solution is found by:

$$\text{Eq. (110)} \quad I_{sys} = \frac{E_S - E_R}{Z_{sys}}$$

As stated in the relay settings in Table 15, the relay is installed on the high-voltage side of the GSU transformer with a pickup of 5.0 per unit current. The maximum allowable current is calculated below.

$$I_{sys} = \frac{(1.05 \angle 120^\circ - 1.05 \angle 0^\circ)}{0.6234 \angle 90^\circ} A$$

$$I_{sys} = \frac{1.775 \angle 150^\circ V}{0.6234 \angle 90^\circ \Omega} A$$

$$I_{sys} = 2.84 \angle 60^\circ A$$

## Application Guidelines

---

The phase instantaneous setting of 5.0 per unit amps is greater than the calculated system current of 2.84 per unit amps; therefore it is compliant with PRC-026-1 – Attachment B, Criteria B.

### Requirement R5

This requirement ensures that all actions associated with any Corrective Action Plan (CAP) developed in the previous requirement are completed. The requirement also permits the entity to modify a CAP as necessary, while in the process of fulfilling the purpose of the standard.

To achieve the stated purpose of this standard, which is to ensure that relays are expected to not trip in response to stable power swings during non-Fault conditions, the applicable entity is required to develop and complete a CAP that reduces the risk of relays tripping during a stable power swing that may occur on any applicable Element of the BES. Protection System owners are required, during the implementation of a CAP, to update it when any action or timetable changes until the CAP is completed. Accomplishing this objective is intended to reduce the risk of the relays unnecessarily tripping during stable power swings, thereby improving reliability and reducing risk to the BES.

The following are examples of actions taken to complete CAPs for a relay that could be exposed to a stable power swing and a setting change was determined to be acceptable (without diminishing the ability of the relay to protect for faults within its zone of protection).

**Example R5a:** Actions: Settings were issued on 6/02/2015 to reduce the zone 2 reach of the impedance relay used in the permissive overreaching transfer trip (POTT) scheme from 30 ohms to 25 ohms so that the relay characteristic is completely contained within the lens characteristic identified by the criterion. The settings were applied to the relay on 6/25/2015. CAP completed on 06/25/2015.

**Example R5b:** Actions: Settings were issued on 6/02/2015 to enable out-of-step blocking on the existing microprocessor-based relay to prevent tripping in response to stable power swings. The setting changes were applied to the relay on 6/25/2015. CAP completed on 06/25/2015.

## Application Guidelines

---

The following is an example of actions taken to complete a CAP for a relay responding to a stable power swing that required the addition of an electromechanical power swing blocking relay.

**Example R5c:** Actions: A project for the addition of an electromechanical power swing blocking relay to supervise the zone 2 impedance relay was initiated on 6/5/2015 to prevent tripping in response to stable power swings. The relay installation was completed on 9/25/2015. CAP completed on 9/25/2015.

The following is an example of actions taken to complete a CAP with a timetable that required updating for the replacement of the relay.

**Example R5d:** Actions: A project for the replacement of the impedance relays at both terminals of line X with line current differential relays was initiated on 6/5/2015 to prevent tripping in response to stable power swings. The completion of the project was postponed due to line outage rescheduling from 11/15/2015 to 3/15/2016. Following the timetable change, the impedance relay replacement was completed on 3/18/2016. CAP completed on 3/18/2016.

The CAP is complete when all the documented actions to resolve the specific problem (i.e., unnecessary tripping during stable power swings) are completed.

## Requirement R6

To achieve the stated purpose of this standard, which is to ensure that load-responsive protective relays are expected to not trip in response to stable power swings during non-Fault conditions, the applicable entity is required to fully implement any CAP developed pursuant to Requirement R5 that modifies the Protection System to meet PRC-026-1 – Attachment B, Criteria A and B. Protection System owners are required in the implementation of a CAP to update it when actions or timetable change, until all actions are complete. Accomplishing this objective is intended to reduce the occurrence of Protection System tripping during a stable power swing, thereby improving reliability and minimizing risk to the BES.

## Standard Development Timeline

*This section is maintained by the drafting team during the development of the standard and will be removed when the standard becomes effective.*

### Development Steps Completed

1. SAR posted for comment from August 19, 2010 through September 19, 2010.
2. SC authorized moving the SAR forward to standard development on August 12, 2010.
3. SC authorized initial posting of draft 1 on April 24, 2014.
4. Draft 1 of PRC-026-1 was posted for a 45-day formal comment period from April 25 – June 9, 2014 and an initial ballot in the last ten days of the comment period from May 30 – June 9, 2014.

### Description of Current Draft

The Protection System Response to Power Swings Standard Drafting Team (PSRPS SDT) is posting Draft ~~1~~<sup>2</sup> of PRC-026-1 – Relay Performance During Stable Power Swings for a 45-day ~~initial~~<sup>additional</sup> comment period and concurrent/parallel ~~initial~~<sup>additional</sup> ballot in the last ten days of the comment period.

Anticipated Actions	Anticipated Date
45-day Formal Comment Period with Concurrent/Parallel Initial Ballot	April 2014
45-day Formal Comment Period with Concurrent/Parallel Additional Ballot	<del>July</del> <sup>August</sup> 2014
Final Ballot	<del>September</del> <sup>October</sup> 2014
<del>BOTNERC</del> <sup>NERC</sup> Board of Trustees Adoption	November 2014

### Version History

Version	Date	Action	Change Tracking
1.0	TBD	Effective Date	New

**PRC-026-1 — Relay Performance During Stable Power Swings**

---


### Definitions of Terms Used in Standard

*This section includes all newly defined or revised terms used in the proposed standard. Terms already defined in the Glossary of Terms Used in Reliability Standards are not repeated here. New or revised definitions listed below become approved when the proposed standard is approved. When the standard becomes effective, these defined terms will be removed from the individual standard and added to the Glossary.*

**Term:** None.



When this standard has received ballot approval, the ~~extrationale~~ boxes will be moved to the Application Guidelines Section of the Standard.

## A. Introduction

1. **Title:** Relay Performance During Stable Power Swings
2. **Number:** PRC-026-1
3. **Purpose:** To ensure that load-responsive protective relays ~~do~~are expected to not trip in response to stable power swings during non-Fault conditions.

4. **Applicability:**

- 4.1. **Functional Entities:**

- 4.1.1 Generator Owner that applies load-responsive protective relays as described in PRC-026-1 – Attachment A at the terminals of the Elements listed in Section 4.2, Facilities.

- 4.1.2 Planning Coordinator.

- ~~4.1.3 Reliability Coordinator.~~

- ~~4.1.4~~4.1.3 Transmission Owner that applies load-responsive protective relays as described in PRC-026-1 – Attachment A at the terminals of the Elements listed in Section 4.2, Facilities.

- ~~4.1.5 Transmission Planner.~~

- 4.2. **Facilities:** The following Bulk Electric System (BES) Elements:

- 4.2.1 Generators.

- 4.2.2 Transformers.

- 4.2.3 Transmission lines.

5. **Background:**

This is ~~Phase 3~~the third phase of a three-phased standard development project that ~~is~~ focused on developing at this new Reliability Standard, ~~PRC-026-1 – Relay Performance During Stable Power Swings~~, to address protective relay operations due to stable power swings. The March 18, 2010, FERC Order No. 733, approved Reliability Standard PRC-023-1 – Transmission Relay Loadability. In this Order, FERC directed NERC to address three areas of relay loadability that include modifications to the approved PRC-023-1, development of a new Reliability Standard to address generator protective relay loadability, and a new Reliability Standard to address the operation of protective relays due to stable power swings. This project's SAR addresses these directives with a three-phased approach to standard development.

Phase 1 focused on making the specific modifications to PRC-023-1 and was completed in the approved Reliability Standard PRC-023-2, which became mandatory on July 1, 2012.

Phase 2 focused on developing a new Reliability Standard, PRC-025-1 – Generator Relay Loadability, to address generator protective relay loadability; PRC-025-1 ~~is currently awaiting regulatory approval~~ was approved by FERC on July 17, 2014.

~~This Phase 3 of the project focuses on developing a new Reliability Standard, PRC-026-1—Relay Performance During Stable Power Swings, to address protective relay operations due to stable power swings. This Reliability Standard will establish~~ This Phase 3 of the project establishes requirements aimed at preventing protective relays from tripping unnecessarily due to stable power swings by requiring ~~each Transmission Owner and Generator Owner~~ the identification of Elements on which a power swing may affect Protection System operation, and to develop requirements to assess the security of load-responsive protective relay systems that are susceptible to operation during power swings, and take actions relays to tripping in response to a stable power swing. Last, to require entities to implement Corrective Action Plans, where necessary, to improve security of security of load-responsive protective relays for stable power swings ~~where such actions would~~ so they are expected to not compromise trip in response to stable power swings during non-Fault conditions while maintaining dependable operation for faults and unstable power swings fault detection and dependable out-of-step tripping.

**6. Effective Date:**

**Requirements R1-R3, R5, and R6**

First day of the first full calendar year that is ~~twelve~~ 12 months ~~beyond~~ after the date that ~~this~~ the standard is approved by an applicable regulatory authorities, or governmental authority or as otherwise provided for in ~~those jurisdictions~~ a jurisdiction where ~~regulatory approval by an applicable governmental authority is required for a standard to go into effect. Where approval by an applicable governmental authority is not required, the standard becomes~~ shall become effective on the first day of the first full calendar year that is ~~twelve~~ 12 months ~~beyond~~ after the date ~~this~~ the standard is ~~approved~~ adopted by the NERC Board of Trustees; or as otherwise ~~made~~ provided for in that jurisdiction.

**Requirement R4**

First day of the first full calendar year that is 36 months after the date that the standard is approved by an applicable governmental authority or as otherwise provided for in a jurisdiction where approval by an applicable governmental authority is required for a standard to go into effect. Where approval by an applicable governmental authority is not required, the standard shall become effective pursuant to the laws applicable to such ERO governmental authorities on the first day of the first full calendar year that is 36 months after the date the standard is adopted by the NERC Board of Trustees or as otherwise provided for in that jurisdiction.

**B. Requirements and Measures**

- R1.** Each Planning Coordinator, ~~Reliability Coordinator, and Transmission Planner~~ shall, within the first month of at least once each calendar year, identify each Element in its area that meets one or more of the following criteria and provide notification to the respective

Generator Owner and Transmission Owner ~~of each Element that meets one or more of the following criteria~~, if any: [Violation Risk Factor: Medium] [Time Horizon: *Operations Planning, Long-term Planning*]

Criteria:

1. ~~An Element that is located or terminates at a generating plant, Generator(s)~~ where a ~~generating plant~~ an angular stability constraint exists ~~and that~~ is addressed by an operating limit or a ~~Special Protection System (SPS) (including line-out conditions)~~ Remedial Action Scheme (RAS) and those Elements terminating at the transmission switching station associated with the generator(s).
  2. An Element that is ~~associated with~~ monitored as part of a System Operating Limit (SOL) that has been established based on angular stability constraints identified in system planning or operating studies ~~(including line-out conditions)~~.
  3. An Element that ~~has formed~~ forms the boundary of an island due to angular instability within ~~an angular stability planning simulation where the system Disturbance(s) that caused the islanding condition continues to be a credible event~~ the most recent underfrequency load shedding (UFLS) assessment.
  4. An Element identified in the most recent Planning Assessment where relay tripping ~~occurred for~~ occurs due to a stable or unstable power swing during a ~~Disturbance~~ simulated disturbance.
  5. An Element reported by the Generator Owner or Transmission Owner pursuant to Requirement R2 or Requirement R3, unless the Planning Coordinator determines the Element is no longer susceptible to power swings.
- M1.** Each Planning Coordinator, ~~Reliability Coordinator, and Transmission Planner~~ shall have dated evidence that demonstrates identification and the respective notification of the Element(s), if any, which meet one or more of the criteria in Requirement R1. Evidence may include, but is not limited to, the following documentation: emails, facsimiles, records, reports, transmittals, lists, or spreadsheets.

**Rationale for R1:** The Planning Coordinator, ~~Reliability Coordinator,~~ has a wide-area view and ~~Transmission Planner are~~ is in position~~the position~~ to identify Elements which meet the criteria, if any. The criterion-based approach is consistent with the NERC System Protection and Control Subcommittee (SPCS) technical document *Protection System Response to Power Swings*, August 2013, (“PSRPS Report”),<sup>1</sup> which ~~recommended~~recommends a focused approach to determine an at-risk Element. ~~Requirements R1, R2, and R3 collectively form an annual assessment. Identification of the Element(s) in the first month of the calendar year allows the remaining time in the calendar year for the relay owners to evaluate Protection Systems (Requirement R3).~~

**R2.** Each ~~Generator Owner and~~ Transmission Owner shall, ~~once each~~within 30 calendar year, ~~identify each Element for which it applies a load-responsive protective relay at a terminal~~ of days of identifying an Element that meets either of the following criteria, ~~if any~~provide notification of the Element to its Planning Coordinator: [Violation Risk Factor: Medium] [Time Horizon: ~~Operations Planning,~~ Long-term Planning]

Criteria:

1. An Element that ~~has tripped since January 1, 2003,~~trips due to a stable or unstable power swing during an actual system Disturbance ~~where the Disturbance(s) that caused the trip~~ due to a power swing continues to be credible~~the operation of its load-responsive protective relays.~~
2. An Element that ~~has formed~~forms the boundary of an island ~~since January 1, 2003,~~ during an actual system Disturbance ~~where the Disturbance(s) that caused the islanding condition continues to be credible~~due to the operation of its load-responsive protective relays.

**M2.** Each ~~Generator Owner and~~ Transmission Owner shall have dated evidence that demonstrates identification of the Element(s), if any, which meet either of the criteria in Requirement R2. Evidence may include, but is not limited to, the following documentation: emails, facsimiles, records, reports, transmittals, lists, or spreadsheets.

---

<sup>1</sup> NERC System Protection and Control Subcommittee, *Protection System Response to Power Swings*, August 2013: [http://www.nerc.com/comm/PC/System%20Protection%20and%20Control%20Subcommittee%20SPCS%20/SPCS%20Power%20Swing%20Report\\_Final\\_20131015.pdf](http://www.nerc.com/comm/PC/System%20Protection%20and%20Control%20Subcommittee%20SPCS%20/SPCS%20Power%20Swing%20Report_Final_20131015.pdf)

**Rationale for R2:** The ~~Generator Owner and~~ Transmission Owner ~~are~~ is in ~~position~~ the position to identify ~~which~~ the load-responsive protective relays ~~that~~ have tripped due to power swings, if any. The ~~criterion-based approach~~ criteria is consistent with the ~~NERC System Protection and Control Subcommittee (SPCS) technical document~~ *Protection System Response to Power Swings, August 2013*, which recommended a focused approach to determine an at-risk Element. Requirements R1, R2, and R3 collectively form an annual assessment. ~~The PSRPS Report. A time period in Requirement R2 and R3 allow to complete a review of the relay owners to allocate time during the calendar year to identify the Element(s) and to evaluate Protection Systems based on their particular circumstance~~ stripping is not addressed here as other NERC Reliability Standards address the review of Protection System operations.

**R3.** Each Generator Owner ~~and Transmission Owner~~ shall, ~~once each within 30~~ calendar year, ~~perform one day~~ of identifying an Element that meets the following ~~for each criterion, provide notification of the Element identified pursuant to Requirement R1 or R2 to its~~ Planning Coordinator: [Violation Risk Factor: Medium] [Time Horizon: Operations Planning, Long-term Planning]

- ~~Demonstrate that the existing Protection System is not expected to trip in response to a stable power swing based on the criterion below.~~
- ~~Demonstrate that the existing Protection System is not expected to trip in response to a stable power swing because power swing blocking is applied.~~
- ~~Develop a Corrective Action Plan (CAP) to modify the Protection System so that the Protection System is not expected to trip in response to a stable power swing based on the criterion below or by applying power swing blocking.~~
- ~~If none of the options above results in dependable fault detection or dependable out-of-step tripping:~~
  - a. ~~obtain agreement from the respective Planning Coordinator, Reliability Coordinator, and Transmission Planner of the Element that the existing Protection System design and settings are acceptable, or~~
  - b. ~~obtain agreement from the respective Planning Coordinator, Reliability Coordinator, and Transmission Planner of the Element that a modification of the Protection System design, settings, or both are acceptable, and develop a CAP for this modification of the Protection System.~~

Criterion:

~~A distance relay impedance characteristic, used for tripping, that is completely contained within the lens characteristic formed in the impedance (R-X) plane that connects the endpoints of the total system impedance by varying the sending end and receiving end voltages from 0 to 1.0 per unit, while maintaining a constant system separation angle across the total system impedance where:~~

1. ~~The system separation angle is:~~

- ~~• At least 120 degrees where power swing blocking is not applied, or~~
- ~~• An angle less than 120 degrees as agreed upon by the Planning Coordinator, Reliability Coordinator, and Transmission Planner where power swing blocking is not applied.~~

- ~~1. All generation is in service and all transmission Elements are in their normal operating state.~~
- ~~2. Sub-transient reactance is used for all machines.~~

1. An Element that trips due to a stable or unstable power swing during an actual system Disturbance due to the operation of its load-responsive protective relays.

M3. Each Generator Owner shall have dated evidence that demonstrates identification of the Element(s), if any, which the criterion in Requirement R3. Evidence may include, but is not limited to, the following documentation: emails, facsimiles, records, reports, transmittals, lists, or spreadsheets.

Rationale for R3: The Generator Owner is in the position to identify the load-responsive protective relays that have tripped due to power swings, if any. The criterion is consistent with the PSRPS Report. A requirement or time to complete a review of the relay tripping is not addressed here as other NERC Reliability Standards address the review of Protection System operations.

R4. Each Generator Owner and Transmission Owner shall, within 12 full calendar months of receiving notification of an Element pursuant to Requirement R1 or within 12 full calendar months of identifying an Element pursuant to Requirement R2 or R3, evaluate each identified Element's load-responsive protective relay(s) based on the PRC-026-1 – Attachment B Criteria where the evaluation has not been performed in the last three calendar years. [*Violation Risk Factor: High*] [*Time Horizon: Operations Planning*]

M3:M4. Each Generator Owner and Transmission Owner shall have dated evidence that demonstrates ~~one of the options~~ evaluation was performed according to Requirement ~~R3~~R4. Evidence may include, but is not limited to, the following documentation: apparent impedance characteristic plots, email, design drawings, facsimiles, R-X plots, software output, records, reports, transmittals, lists, settings sheets, or spreadsheets.

**Rationale for R3:** Performing one of the options in Requirement R3 assures that the reliability goal of this standard will be met. The first option ensures that the Generator Owner and Transmission Owner protective relays are secure from tripping in response to stable power swings having a system separation angle of up to 120 degrees. The second option allows the Generator Owner and Transmission Owner to exclude protective relays that have power swing blocking applied. The third option allows the Generator Owner and Transmission Owner, where possible, to modify the Protection System to meet the criterion or apply power swing blocking. The fourth option allows the Generator Owner and Transmission Owner to maintain a balance between Protection System security and dependability for cases where tripping on stable power swings may be necessary to maintain the ability to trip for unstable power swings or faults; however, agreement is required by others to ensure that tripping for a stable power swing is acceptable. Protection System modifications may be necessary to achieve acceptable performance. A time period of once each calendar year allows time to evaluate the Protection System, develop a CAP, or obtain necessary agreement. **Rationale for R4:** Performing the evaluation in Requirement R4 is the first step in ensuring that the reliability goal of this standard will be met. The PRC-026-1 – Attachment B, Criteria provides a basis for determining if the relays are expected to not trip for a stable power swing. See the Guidelines and Technical Basis for a detailed explanation of the evaluation.

~~R4~~R5. Each Generator Owner and Transmission Owner shall ~~implement each CAP developed,~~ within 60 calendar days of an evaluation that identifies load-responsive protective relays that do not meet the PRC-026-1 – Attachment B Criteria pursuant to Requirement ~~R3~~R4, ~~develop a Corrective Action Plan (CAP) to modify the Protection System to meet the PRC-026-1 – Attachment B Criteria while maintaining dependable fault detection and update each CAP dependable out-of-step tripping (if actions or timetables change, until all actions are complete, out-of-step tripping is applied at the terminal of the Element).~~ [Violation Risk Factor: Medium][Time Horizon: Operations Planning, ~~Long Term Planning~~]

~~M4~~M5. \_\_\_\_\_ The Generator Owner and Transmission Owner shall have dated evidence that demonstrates ~~implementation~~the development of ~~each~~a CAP ~~according to~~in accordance with Requirement ~~R4, including updates to actions or timetables~~R5. Evidence may include, but is not limited to, the following documentation: corrective action plans, maintenance records, settings sheets, project or work management program records, or work orders.

**Rationale for R4:** ~~Implementation of the CAP must accomplish all identified actions to be complete to achieve the desired reliability goal. During the course of implementing a CAP, updates may be necessary for a variety of reasons such as new information, scheduling conflicts, or resource issues. Documenting changes and completion of activities provides measurable progress and confirmation of completion.~~ **Rationale for R5:** To meet the reliability purpose of the standard, a CAP is necessary to modify the entity’s Protection System to meet PRC-026-1 – Attachment B so that protective relays are expected to not trip in response to stable power swings. The phrase, “while maintaining dependable fault detection and dependable out-of-step tripping” in Requirement R5 describes that the entity is to comply with this standard while achieving their desired protection goals. Refer to the Guidelines and Technical Basis, Introduction, for more information.

**R6.** Each Generator Owner and Transmission Owner shall implement each CAP developed pursuant to Requirement R5, and update each CAP if actions or timetables change until all actions are complete. [Violation Risk Factor: Medium][Time Horizon: Long-Term Planning]

**M6.** The Generator Owner and Transmission Owner shall have dated evidence that demonstrates implementation of each CAP according to Requirement R6, including updates to actions or timetables. Evidence may include, but is not limited to, the following documentation: corrective action plans, maintenance records, settings sheets, project or work management program records, or work orders.

**Rationale for R6:** Implementation of the CAP must accomplish all identified actions to be complete to achieve the desired reliability goal. During the course of implementing a CAP, updates may be necessary for a variety of reasons such as new information, scheduling conflicts, or resource issues. Documenting changes and completion of activities provides measurable progress and confirmation of completion.

## C. Compliance

### 1. Compliance Monitoring Process

#### 1.1. Compliance Enforcement Authority

As defined in the NERC Rules of Procedure, “Compliance Enforcement Authority” (CEA) means NERC or the Regional Entity in their respective roles of monitoring and enforcing compliance with the NERC Reliability Standards.

#### 1.2. Evidence Retention

The following evidence retention periods identify the period of time an entity is required to retain specific evidence to demonstrate compliance. For instances where the evidence retention period specified below is shorter than the time since



the last audit, the CEA may ask an entity to provide other evidence to show that it was compliant for the full time period since the last audit.

The Generator Owner, Planning Coordinator, ~~Reliability Coordinator,~~  
~~Transmission Owner,~~ and Transmission ~~Planner~~Owner shall keep data or evidence to show compliance as identified below unless directed by its CEA to retain specific evidence for a longer period of time as part of an investigation.

- The Planning Coordinator, ~~Reliability Coordinator, and Transmission Planner~~ shall retain evidence of ~~Requirements~~Requirement R1, ~~Measures M1~~ for a minimum of three calendar years following the completion of each Requirement.
- The Transmission Owner shall retain evidence of Requirement R2 for a minimum of three calendar years following the completion of each Requirement.
- The Generator Owner shall retain evidence of Requirement R3 for a minimum of three calendar years following the completion of each Requirement.
- The Generator Owner and Transmission Owner shall retain evidence of ~~Requirements R2 and R3, Measures M2 and M3~~Requirement R4 for threea minimum of 36 calendar yearsmonths following completion of each evaluation.
- The Generator Owner and Transmission Owner shall retain evidence of Requirements ~~R4, Measures M4 for~~R5 and R6, including any supporting analysis per Requirements R1, R2, R3, and R4, for a minimum of 12 calendar months following completion of each CAP.

If a Generator Owner, Planning Coordinator, ~~Reliability Coordinator,~~  
~~Transmission Owner,~~ or Transmission ~~Planner~~Owner is found non-compliant, it shall keep information related to the non-compliance until mitigation is complete and approved, or for the time specified above, whichever is longer.

The CEA shall keep the last audit records and all requested and submitted subsequent audit records.

### 1.3. Compliance Monitoring and Assessment Processes:

Compliance Audit

Self-Certification

Spot Checking

Compliance Violation Investigation

Self-Reporting

Complaint

### 1.4. Additional Compliance Information

None.



Table of Compliance Elements

R#	Time Horizon	VRF	Violation Severity Levels			
			Lower VSL	Moderate VSL	High VSL	Severe VSL
R1	<del>Operations Planning;</del> Long-term Planning	Medium	The <del>responsible entity</del> <u>Planning Coordinator</u> identified an Element and provided notification in accordance with Requirement R1, but was less than or equal to 30 calendar days late.	The <del>responsible entity</del> <u>Planning Coordinator</u> identified an Element and provided notification in accordance with Requirement R1, but was more than 30 calendar days and less than or equal to 60 calendar days late.	The <del>responsible entity</del> <u>Planning Coordinator</u> identified an Element and provided notification in accordance with Requirement R1, but was more than 60 calendar days and less than or equal to 90 calendar days late.	The <del>responsible entity</del> <u>Planning Coordinator</u> identified an Element and provided notification in accordance with Requirement R1, but was more than 90 calendar days late.  OR The <del>responsible entity</del> <u>Planning Coordinator</u> failed to identify an Element <del>or</del> <u>in accordance with Requirement R1.</u>  OR <u>The Planning Coordinator failed</u> to provide notification in accordance with Requirement R1.
R2	<del>Operations Planning;</del>	Medium	The <del>responsible entity</del> <u>Transmission</u>	The <del>responsible entity</del> <u>Transmission</u>	The <del>responsible entity</del> <u>Transmission</u>	The <del>responsible entity</del> <u>Transmission</u>

R#	Time Horizon	VRF	Violation Severity Levels			
			Lower VSL	Moderate VSL	High VSL	Severe VSL
	Long-term Planning		<u>Owner</u> identified <u>an Element and provided notification</u> in accordance with Requirement R2, but was less than or equal to <u>3010</u> calendar days late.	<u>Owner</u> identified <u>an Element and provided notification</u> in accordance with Requirement R2, but was more than <u>3010</u> calendar days and less than or equal to <u>6020</u> calendar days late.	<u>Owner</u> identified <u>an Element and provided notification</u> in accordance with Requirement R2, but was more than <u>6020</u> calendar days and less than or equal to <u>9030</u> calendar days late.	<u>Owner</u> identified <u>an Element and provided notification</u> in accordance with Requirement R2, but was more than <u>9030</u> calendar days late. OR The <u>responsible entity Transmission Owner</u> failed to identify an Element in accordance with Requirement R2. <u>OR</u> The <u>Transmission Owner</u> failed to <u>provide notification in accordance with Requirement R2.</u>
<b>R3</b>	<u>Operations Planning, Long-term Planning</u>	Medium	The <u>responsible entity performed one of the options Generator Owner</u> identified <u>an Element and provided notification</u> in accordance with	The <u>responsible entity performed one of the options Generator Owner</u> identified <u>an Element and provided notification</u>	The <u>responsible entity performed one of the options Generator Owner</u> identified <u>an Element and provided notification</u>	The <u>responsible entity performed one of the options Generator Owner</u> identified <u>an Element and provided notification</u>

R#	Time Horizon	VRF	Violation Severity Levels			
			Lower VSL	Moderate VSL	High VSL	Severe VSL
			Requirement R3, but was less than or equal to <del>30</del> <u>10</u> calendar days late.	in accordance with Requirement R3, but was more than <del>30</del> <u>10</u> calendar days and less than or equal to <del>60</del> <u>20</u> calendar days late.	in accordance with Requirement R3, but was more than <del>60</del> <u>20</u> calendar days and less than or equal to <del>90</del> <u>30</u> calendar days late.	in accordance with Requirement R3, but was more than <del>90</del> <u>30</u> calendar days late.  OR The <del>responsible entity</del> <u>Generator Owner</u> failed to <del>perform one of the options</del> <u>identify an Element</u> in accordance with Requirement R3.  <u>OR</u> <u>The Generator Owner failed to provide notification in accordance with Requirement R3.</u>
<b>R4</b>	Operations Planning, <del>Long term Planning</del>	<del>Medium</del> <u>High</u>	The <del>responsible entity implemented, but failed to update a CAP, when actions</del> <u>Generator Owner or timetables changed, Transmission Owner evaluated each</u>	<del>N/A</del> <u>The Generator Owner or Transmission Owner evaluated each identified Element's load-responsive protective relay(s) in accordance with</u>	<del>N/A</del> <u>The Generator Owner or Transmission Owner evaluated each identified Element's load-responsive protective relay(s) in accordance with</u>	The <del>responsible entity</del> <u>Generator Owner or Transmission Owner</u> evaluated each identified Element's load-responsive protective relay(s) in

R#	Time Horizon	VRF	Violation Severity Levels			
			Lower VSL	Moderate VSL	High VSL	Severe VSL
			<u>identified Element's load-responsive protective relay(s) in accordance with Requirement R4, but was less than or equal to 30 calendar days late.</u>	<u>Requirement R4, but was more than 30 calendar days and less than or equal to 60 calendar days late.</u>	<u>Requirement R4, but was more than 60 calendar days and less than or equal to 90 calendar days late.</u>	<u>accordance with Requirement R4, but was more than 90 calendar days late.</u>  <u>OR</u> <u>The Generator Owner or Transmission Owner failed to implement a CAPEvaluate each identified Element's load-responsive protective relay(s) in accordance with Requirement R4.</u>
<u>R5</u>	<u>Long-term Planning</u>	<u>Medium</u>	<u>The Generator Owner or Transmission Owner developed a CAP in accordance with Requirement R5, but in more than 60 calendar days and less than or equal to 70 calendar days.</u>	<u>The Generator Owner or Transmission Owner developed a CAP in accordance with Requirement R5, but in more than 70 calendar days and less than or equal to 80 calendar days.</u>	<u>The Generator Owner or Transmission Owner developed a CAP in accordance with Requirement R5, but in more than 80 calendar days and less than or equal to 90 calendar days.</u>	<u>The Generator Owner or Transmission Owner developed a CAP in accordance with Requirement R5, but in more than 90 calendar days.</u>  <u>OR</u> <u>The Generator Owner or Transmission Owner</u>

R#	Time Horizon	VRF	Violation Severity Levels			
			Lower VSL	Moderate VSL	High VSL	Severe VSL
						<u>failed to develop a CAP in accordance with Requirement R5.</u>
<u>R6</u>	<u>Long-term Planning</u>	<u>Medium</u>	<u>The Generator Owner or Transmission Owner implemented, but failed to update a CAP, when actions or timetables changed, in accordance with Requirement R6.</u>	<u>N/A</u>	<u>N/A</u>	<u>The Generator Owner or Transmission Owner failed to implement a CAP in accordance with Requirement R6.</u>

#### D. Regional Variances

None.

#### E. Interpretations

None.

#### F. Associated Documents

*Applied Protective Relaying*, Westinghouse Electric Corporation, 1979.

*Burdy, John, Loss-of-excitation Protection for Synchronous Generators GER-3183*, General Electric Company.

IEEE Power System Relaying Committee WG D6: *Power Swing and Out-of-Step Considerations on Transmission Lines*, July 2005: <http://www.pes-psrc.org/Reports/Power%20Swing%20and%20OOS%20Considerations%20on%20Transmission%20Lines%20F..pdf>.

*Kimbark Edward Wilson, Power System Stability, Volume II: Power Circuit Breakers and Protective Relays*, Published by John Wiley and Sons, 1950.

Kundar, Prabha: *Power System Stability and Control*, 1994, Palo Alto: EPRI, McGraw Hill, Inc.

NERC System Protection and Control Subcommittee: *Protection System Response to Power Swings*, August 2013: [http://www.nerc.com/comm/PC/System%20Protection%20and%20Control%20Subcommittee%20SPCS%2020/SPCS%20Power%20Swing%20Report\\_Final\\_20131015.pdf](http://www.nerc.com/comm/PC/System%20Protection%20and%20Control%20Subcommittee%20SPCS%2020/SPCS%20Power%20Swing%20Report_Final_20131015.pdf).

Reimert, Donald: *Protective Relaying for Power Generation Systems*, 2006, Boca Raton: CRC Press.



Guidelines and Technical Basis

### PRC-026-1 – Attachment A

This standard includes any protective functions which could trip instantaneously or with a time delay of less than 15 cycles, on load current (i.e., “load-responsive”) including, but not limited to:

- Phase distance
- Phase overcurrent
- Out-of-step tripping
- Loss-of-field

The following protection functions are excluded from requirements of this standard:

- Relay elements supervised by power swing blocking
- Relay elements that are only enabled when other relays or associated systems fail. For example:
  - Overcurrent elements that are only enabled during loss of potential conditions.
  - Elements that are only enabled during a loss of communications
- Thermal emulation relays which are used in conjunction with dynamic Facility Ratings
- Relay elements associated with dc lines
- Relay elements associated with dc converter transformers
- Phase fault detector relay elements employed to supervise other load-responsive phase distance elements (e.g., in order to prevent false operation in the event of a loss of potential) provided the distance element is set in accordance with the criteria outlined in the standard
- Relay elements associated with switch-onto-fault schemes
- Reverse power relay on the generator
- Generator relay elements that are armed only when the generator is disconnected from the system, (e.g., non-directional overcurrent elements used in conjunction with inadvertent energization schemes, and open breaker flashover schemes)
- Current differential relay, pilot wire relay, and phase comparison relay
- Voltage-restrained or voltage-controlled overcurrent relays

### PRC-026-1 – Attachment B

#### Criteria A:

An impedance-based relay characteristic, used for tripping, that is completely contained within the portion of the lens characteristic formed in the impedance (R-X) plane that connects the endpoints of the total system impedance (with the parallel transfer impedance removed) bounded by varying the sending- and receiving-end voltages from 0.7 to 1.0 per unit, while maintaining a constant system separation angle across the total system impedance where:

2. The system separation angle is:
  - At least 120 degrees, or
  - An angle less than 120 degrees where a documented transient stability analysis demonstrates the expected maximum stable separation angle is less than 120 degrees.
3. All generation is in service and all transmission Elements are in their normal operating state when calculating the system impedance.
4. Saturated (transient or sub-transient) reactance is used for all machines.

**Rationale for Attachment B (Criteria A):** The PRC-026-1, Attachment B, Criteria A provides a basis for determining if the relays are expected to not trip for a stable power swing having a system separation angle of up to 120 degrees with the sending-end and receiving-end voltages varying from 0.7 to 1.0 per unit (See Guidelines and Technical Basis).

#### Criteria B:

The pickup of an overcurrent relay element used for tripping, that is above the calculated current value (with the parallel transfer impedance removed) for the conditions below:

1. The system separation angle is:
  - At least 120 degrees, or
  - An angle less than 120 degrees where a documented transient stability analysis demonstrates the expected maximum stable separation angle is less than 120 degrees.
2. All generation is in service and all transmission Elements are in their normal operating state when calculating the system impedance.
3. Saturated (transient or sub-transient) reactance is used for all machines.
4. Both the sending and receiving voltages at 1.05 per unit.

**Rationale for Attachment B (Criteria B):** The PRC-026-1, Attachment B, Criteria B provides a basis for determining if the relays are expected to not trip for a stable power swing having a system separation angle of up to 120 degrees with the sending and receiving voltages at 1.05 per unit (See Guidelines and Technical Basis).

### Guidelines and Technical Basis

#### Introduction

The NERC System Protection and Control Subcommittee technical document, *Protection System Response to Power Swings*, August 2013<sup>2</sup> (“PSRPS Report” or “report”) was specifically prepared to support the development of this NERC Reliability Standard. The report provided a historical perspective on power swings as early as 1965 up through the approval of the report by the NERC Planning Committee. The report also addresses reliability issues regarding trade-offs between security and dependability of protection systems, considerations for this NERC Reliability Standard, and a collection of technical information about power swing characteristics and varying issues with practical applications and approaches to power swings. Of these topics, the ~~PSRPS Report~~report suggests an approach for this NERC Reliability Standard (“standard” or “PRC-026-1”) which is consistent with addressing two of the three regulatory directives in the FERC Order No. 733. The first directive concerns the need for “...protective relay systems that differentiate between faults and stable power swings and, when necessary, phases out protective relay systems that cannot meet this requirement.”<sup>3</sup> Second, is “...to develop a Reliability Standard addressing undesirable relay operation due to stable power swings.”<sup>4</sup> The third directive “...to consider “islanding” strategies that achieve the fundamental performance for all islands in developing the new Reliability Standard addressing stable power swings”<sup>5</sup> was considered during development of the standard.

~~The development of this NERC Reliability Standard implements the majority of the approach suggested by the PSRPS Report. These guidelines include a narrative of any deviation in the report’s approach.~~standard implements the majority of the approach suggested by the report. However, it is noted that the Reliability Coordinator and Transmission Planner have not been included in the standard’s Applicability (as suggested by the PSRPS Report). This is so that a single entity, the Planning Coordinator, may be the single source for identifying Elements according to Requirement R1. A single source will insure that multiple entities will not identify Elements in duplicate, nor will one entity fail to provide an Element because it believes the Element is being provided by another entity. The Planning Coordinator has, or has access to, the wide-area model and can correctly identify the Elements that may be susceptible to a stable power swing.

The phrase, “while maintaining dependable fault detection and dependable out-of-step tripping” in Requirement R1, describes that the Generator Owner and Transmission Owner is to comply

---

<sup>2</sup> NERC System Protection and Control Subcommittee ~~technical document~~, *Protection System Response to Power Swings*, August 2013:  
[http://www.nerc.com/comm/PC/System%20Protection%20and%20Control%20Subcommittee%20SPCS%2020/SPCS%20Power%20Swing%20Report\\_Final\\_20131015.pdf](http://www.nerc.com/comm/PC/System%20Protection%20and%20Control%20Subcommittee%20SPCS%2020/SPCS%20Power%20Swing%20Report_Final_20131015.pdf)

<sup>3</sup> Transmission Relay Loadability Reliability Standard, Order No. 733, P.150 FERC ¶ 61,221 (2010).

<sup>4</sup> Ibid. P.153.

<sup>5</sup> Ibid. P.162.

## Application Guidelines

---

with this standard while achieving its desired protection goals. Load-responsive protective relays, as addressed within this standard, may be intended to provide a variety of backup protection functions, both within the generating unit or generating plant and on the Transmission system, and this standard is not intended to result in the loss of these protection functions. Instead, it is suggested that the Generator Owner and Transmission Owner consider both the requirements within this standard and its desired protection goals, and perform modifications to its protective relays or protection philosophies as necessary to achieve both.

### **Power Swings**

The IEEE Power System Relaying Committee WG D6 developed a technical document called *Power Swing and Out-of-Step Considerations on Transmission Lines* (July 2005) that provides background on power swings. The following are general definitions from that document:<sup>6</sup>

Power Swing: a variation in three phase power flow which occurs when the generator rotor angles are advancing or retarding relative to each other in response to changes in load magnitude and direction, line switching, loss of generation, faults, and other system disturbances.

Pole Slip: a condition whereby a generator, or group of generators, terminal voltage angles (or phases) go past 180 degrees with respect to the rest of the connected power system.

Stable Power Swing: a power swing is considered stable if the generators do not slip poles and the system reaches a new state of equilibrium, i.e. an acceptable operating condition.

Unstable Power Swing: a power swing that will result in a generator or group of generators experiencing pole slipping for which some corrective action must be taken.

Out-of-Step Condition: Same as an unstable power swing.

Electrical System Center or Voltage Zero: it is the point or points in the system where the voltage becomes zero during an unstable power swing.

### **Burden to Entities**

The PSRPS Report provides a technical basis and approach for focusing on Protection Systems, which are susceptible to power swings while achieving the reliability objective. The approach reduces the number of relays ~~for which that~~ the ~~requirements~~ PRC-026-1 Requirements would apply to by first identifying the Bulk Electric System (BES) Element(s) that need to be evaluated. The first step uses criteria to identify a BES Element on which a Protection System is expected to be challenged by power swings. Of those BES Elements, the second step is to ~~identify the Element(s) that apply~~ aevaluate each load-responsive protective relay that is applied

---

<sup>6</sup> <http://www.pes-psrc.org/Reports/Power%20Swing%20and%20OOS%20Considerations%20on%20Transmission%20Lines%20F..pdf>.

## Application Guidelines

---

on each identified Element. Rather than requiring the Transmission Planner to perform simulations to obtain information for each identified Element(s),<sup>2</sup> the Generator Owner and Transmission Owner will reduce the need for simulation by comparing the load-responsive protective relay characteristic to ~~a specific criterion~~ criteria found in PRC-026-1 – Attachment B.

### Applicability

The standard is applicable to the Generator Owner, Planning Coordinator, ~~Reliability Coordinator, Transmission Owner,~~ and Transmission ~~Planner~~Owner entities. More specifically, the Generator Owner and Transmission Owner entities are applicable when applying load-responsive protective relays at the terminals of the applicable BES Elements. All the entities have a responsibility to identify the Elements which meet specific criteria. The standard is applicable to the following BES Elements: generators, transmission lines, and transformers. The Distribution Provider was considered for inclusion in the standard; however, it is not subject to the standard because this entity,<sup>2</sup> by functional registration,<sup>2</sup> would not own generators, transmission lines, or transformers other than load serving.

Load-responsive protective relays include any protective functions which could trip with or without time delay, on load current.

### Requirement R1

~~In the first month of each calendar year this requirement initiates the identification of the Elements that meet specific criteria known by the Planning Coordinator, Reliability Coordinator, and the Transmission Planner.~~

~~Because the dynamic studies performed by the Planning Coordinator and the Transmission Planner vary by region, it is important for both of these entities to have a reliability requirement to identify such Elements. The Reliability Coordinator is also included because of its wide area awareness of the BES and its unique potential to identify Elements susceptible to tripping due to power swings.~~

The Planning Coordinator has a wide-area view and is in the position to identify what, if any, Elements meet the criteria. The criterion-based approach is consistent with the NERC System Protection and Control Subcommittee (SPCS) technical document *Protection System Response to Power Swings* (August 2013),<sup>7</sup> which recommends a focused approach to determine an at-risk Element. Identification of Elements comes from the annual Planning Assessments pursuant to the transmission planning (i.e., “TPL”) and other NERC Reliability Standards, and the standard is not requiring any other assessments to be performed by the Planning Coordinator. The required annual notification to the respective Generator Owner and Transmission Owner is

---

<sup>7</sup> [http://www.nerc.com/comm/PC/System%20Protection%20and%20Control%20Subcommittee%20SPCS%2020/SPCS%20Power%20Swing%20Report\\_Final\\_20131015.pdf](http://www.nerc.com/comm/PC/System%20Protection%20and%20Control%20Subcommittee%20SPCS%2020/SPCS%20Power%20Swing%20Report_Final_20131015.pdf)

sufficient because it is expected that the Planning Coordinator will make its notifications following the completion of its annual Planning Assessments.

### **Criterion 1**

The first criterion involves ~~Elements that are located at or terminate at a generator(s) where an angular stability constraint exists which is addressed by an operating limit or a Remedial Action Scheme (RAS) and those Elements terminating at the transmission switching station associated with the generator(s).~~ For example, a scheme to remove generation for specific conditions is implemented for a four-unit generating plant ~~where an existing stability constraint has been established and is managed by either a specific operating limit or a Special Protection System (SPS). For example, assume a (1,100 MW).~~ Two of the units are 500 MW each; one is connected to the 345 kV system and one is connected to the 230 kV system. The Transmission Owner has two 230 kV transmission lines and one 345 kV transmission line all terminating at the generating facility as well as a 345/230 kV autotransformer. The remaining 100 MW consists of two 50 MW combustion turbine (CT) units connected to four 66 kV transmission lines. The 66 kV transmission is not electrically joined to the 345 kV and 230 kV transmission lines at the plant ~~contains two 500 MW generating units, one connected to a 345 kV bus and one connected to site and is not a 230 kV bus. Assume a single transformer connects the 345 kV bus to the 230 kV bus, and that the plant is connected to the rest of the BES through a single 345 kV transmission circuit and two 230 kV circuits. Assume a stability constraint exists that part of the operating limit or RAS. A stability constraint limits the output of the portion of the plant affected by the RAS to 700 MW for an outage of the 345 kV transmission line, and that a SPS exists to run back the output. The RAS trips one of the generating plant to 700/500 MW units to maintain stability for a loss of the 345 kV transmission line, when the total output from both 500 MW units is above 700 MW.~~ For this ~~hypothetical~~ example, both 500 MW generating units ~~would be included as Elements meeting the criterion. Furthermore, and~~ the associated generator step-up (GSU) transformers, ~~the generator interconnection, the 345-230 kV power transformer, and the two 230 kV transmission circuits~~ would be identified as Elements meeting thethis criterion. The 345/230 kV autotransformer, the 345 kV transmission circuitline, and the two 230 kV transmission lines would also be identified as Elements meeting this criterion. The 50 MW combustion turbines and 66 kV transmission lines would not be identified as ~~meeting the criterion since the event that triggered the stability constraint is a loss of the 345 kV transmission circuit~~ pursuant Criterion 1 because these Elements are not subject to an operating limit or RAS and do not terminate at the transmission switching station associated with the generators that are subject to the operating limit and RAS.

### **Criterion 2**

The second criterion involves Elements that ~~have~~ are monitored due to an established System Operating Limit (SOL) based on aan angular stability limit ~~or issue driven by one or more specific events~~ regardless of the outage conditions that result in the enforcement of the SOL. For example, if two long parallel 500 kV transmission lines have a combined SOL of 1,200 MW, and this limit is based on angular instability resulting from a fault and subsequent loss of one of the two ~~circuits~~ lines, then both circuits lines would be identified as an Element meeting the criterion.

### **Criterion 3**

The third criterion involves the Element that ~~has formed~~forms the boundary of an island due to angular instability within an ~~angular stability planning simulation~~underfrequency load shedding (UFLS) assessment. While the island may form due to various transmission ~~circuits~~lines tripping for a combination of reasons, such as stable and unstable power swings, faults, and excessive loading, the criterion requires that all lines that tripped in simulation due to “angular instability” to form the island be identified as meeting the criterion.

~~The last criterion allows the Planning Coordinator and Transmission Planner to include any other Elements revealed in Planning Assessments.~~

### **Requirement R2**

~~The approach of Requirement R2 requires the Generator Owner and Transmission Owner to identify Elements once each calendar year that meet the focused criteria specific to these entities. The only Elements that are in scope are Elements that meet the criteria and apply a load-responsive protective relay at the terminal of the Element. Using the criteria focuses the reliability concern on the Element that is at risk.~~

~~The first criterion involves Elements that have tripped for actual power swings, regardless of whether the power swing was stable or unstable. In order to ensure previous trips due to power swings are considered, the entity must consider Disturbances since January 1, 2003 in order to capture the August 14, 2003 Blackout.<sup>8</sup> In consideration that BES topologies change, the Requirement includes a provision to exclude the Element where a historical Disturbance is no longer credible; meaning the Disturbance is no longer capable of occurring in the future due to actual changes to the BES.~~

~~The second criterion involves the formation of an island based on an actual Disturbance. While the island may form due to various transmission circuits tripping for a combination of reasons, such as power swings (stable or unstable), faults, or excessive loading, the criterion requires that all lines that tripped to form the island be identified as meeting the criterion. This criterion also has an exception similar to the first criterion. Any event that caused an actual island to form since August 1, 2003 that is no longer credible due to actual changes to the BES is not required be used to identify Elements as meeting the criterion.~~

~~For example, assume eight lines connect an area containing~~

### **Criterion 4**

~~The fourth criterion involves Elements identified in the most recent Planning Assessment where relay tripping occurs due to a stable or unstable power swing during a simulated disturbance. The intent is for the Planning Coordinator to include any Element(s) where relay tripping was~~

---

<sup>8</sup> [http://www.nerc.com/pa/trm/ea/pages/blackout\\_august\\_2003.aspx](http://www.nerc.com/pa/trm/ea/pages/blackout_august_2003.aspx)



## Application Guidelines

---

observed during simulations performed for the most recent Planning Assessment associated with the transmission planning TPL-001-4 Reliability Standard. Note that relay tripping must be assessed within Planning Assessments per TPL-001-4, R4, Part 4.3.1.3, which indicates that analysis shall include the “Tripping of Transmission lines and transformers where transient swings cause Protection System operation based on generic or actual relay models.” Identifying such Elements according to criterion 4 and notifying the respective Generator Owner and Transmission Owner will require that the owners of any load-responsive protective relay applied at the terminals of the identified Element evaluate the relay’s susceptibility to tripping in response a stable power swing.

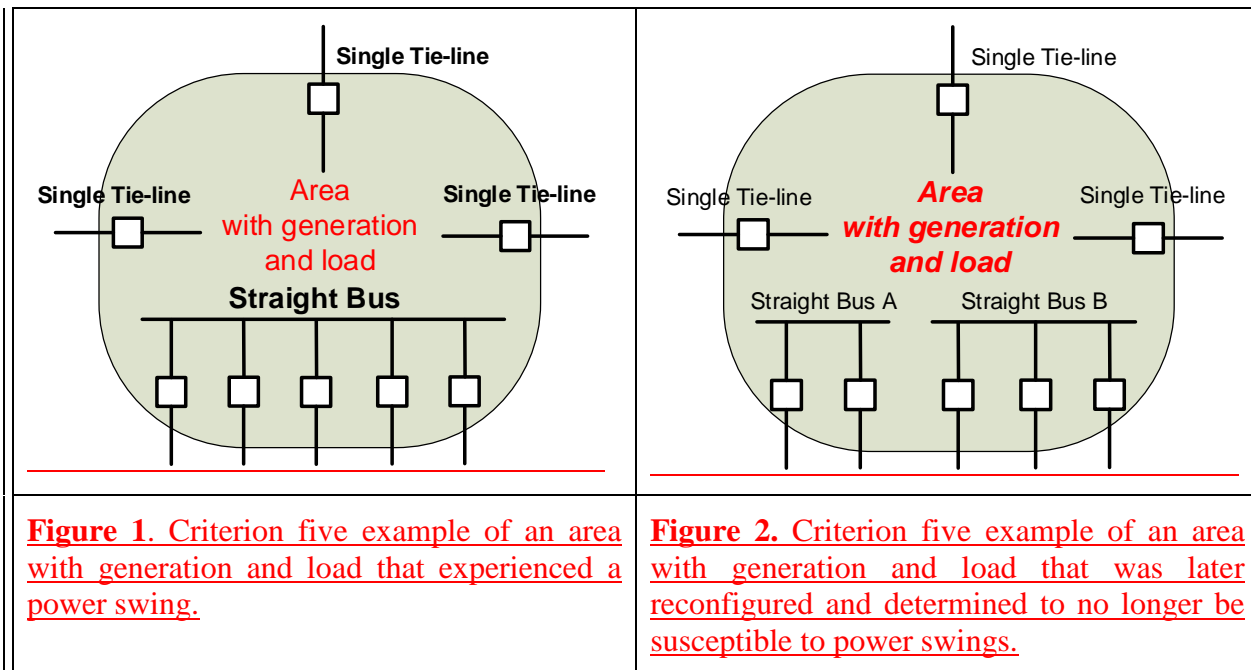
Planning Coordinators have discretion to determine whether observed tripping for a power swing in its Planning Assessments occurs for valid contingencies and system conditions. The Planning Coordinator will address tripping that is observed in transient analyses on an individual basis; therefore, the Planning Coordinator is responsible for identifying the Elements based only on simulation results that are determined to be valid.

Due to the nature of how a Planning Assessment is performed, there may be cases where a previously identified Element is not identified in the most recent Planning Assessment. If so, this is acceptable because the Generator Owner and Transmission Owner would have taken action upon the initial notification of the previously identified Element. When an Element is not identified in later Planning Assessments, the risk would have already been assessed under Requirement R4 and mitigated according to Requirements R5 and R6 when appropriate. According to Requirement R4, the Generator Owner and Transmission Owner are only required to re-evaluate each load-responsive protective relay for an identified Element where the evaluation has not been performed in the last three calendar years.

### **Criterion 5**

The fifth criterion involves Elements that have actually tripped due to a stable or unstable power swing as reported by the Generator Owner and Transmission Owner. The Planning Coordinator will continue to identify each reported Element until the Planning Coordinator determines that the Element is expected to not trip in response to power swings due to BES configuration changes. For example, eight lines interconnecting areas containing both generation and load to the rest of the BES, and five of the lines terminate on a single straight bus. Assume a as shown in Figure 1. A forced outage of the straight bus in the past caused an island to form by tripping open the five lines connecting to the straight bus, and subsequently causing the other three lines into the area to trip on power swings ~~or excessive loading.~~ If the BES is reconfigured such that the five lines into the straight bus are now divided between two different substations, a single Disturbance that caused the five lines to open is no longer a credible event; therefore, these Elements should not be identified as meeting the criterion based on this particular event. If any other event remains credible for the Element, then it would be identified under the criterion. The Planning Coordinator may determine that the changes eliminated susceptibility to power swings as shown in Figure 2. If so, the Planning Coordinator is no longer required to identify these Elements previously reported by either the Transmission Owner pursuant to Requirement R2 or Generator Owner pursuant to Requirement R3.

## Application Guidelines



Although Requirement R1 requires the Planning Coordinator to notify the respective Generator Owner and Transmission Owner of any Elements meeting the one or more of the five criteria, it does not preclude the Planning Coordinator from providing additional information, such as apparent impedance characteristics, in advance or upon request, that may be useful in evaluating protective relays. Generator Owners and Transmission Owners are able to complete protective relay evaluations and perform the required actions without additional information. The standard does not include any requirement for the entities to provide information that is already being shared or exchanged between entities for operating needs. While a requirement has not been included for the exchange of information, entities must recognize that relay performance needs to be measured against the most current information.

### **Requirement R2**

The approach of Requirement R2 requires the Transmission Owner to identify Elements that meet the focused criteria. Only the Elements that meet the criteria and apply a load-responsive protective relay at the terminal of the Element are in scope. Using the criteria focuses the reliability concern on the Element that is at-risk to power swings.

The first criterion involves Elements that have tripped due to a power swing during an actual system Disturbance, regardless of whether the power swing was stable or unstable. Elements that have tripped by unstable power swings are included in this requirement because they were not identified in Requirement R1 and this forms a basis for evaluating the load responsive relay operation for stable power swings. After this standard becomes effective, if it is determined in an outage investigation that an Element tripped because of a power swing condition (either stable or unstable), this standard will become applicable to the Element. An example of an identified Element is an Element tripped by a distance relay element (i.e., a relay with a time delay of less

## Application Guidelines

---

than 15 cycles) during a power swing condition. Another example that would identify an Element is where out-of-step (OOS) tripping is applied on the Element, and if a legitimate OOS trip occurred as expected during a power swing event.

The second criterion involves the formation of an island based on an actual system Disturbance. While the island may form due to several transmission lines tripping for a combination of reasons, such as power swings (stable or unstable), faults, or excessive loading, the criterion requires that all Elements that tripped to form the island be identified as meeting this criterion. For example, the Disturbance may have been initiated by one line faulting with a second line being out of service. The outage of those two lines then initiated a swing condition between the “island” and the rest of the system across the remaining ties causing the remaining ties to open. A second case might be that the island could have formed by a fault on one of the other ties with a line out of service with the swing going across the first and second lines mentioned above resulting in those lines opening due to the swing. Therefore, the inclusion of all the Elements that formed the boundary of the island are included as Elements to be reported to the Planning Coordinator.

The owner of the load-responsive protective relay that tripped for either criterion is required to identify the Element and notify its Planning Coordinator. Notifying the Planning Coordinator of the Element ensures that the planner is aware of an Element that is susceptible to a power swing or formed an island. The Planning Coordinator will continue to notify the respective entities of the identified Element under Requirement R1, Criterion 5 unless the Planning Coordinator determines the Element is no longer susceptible to power swings.

### Requirement R3

The purpose of Requirement R3 is similar to ~~provide alternatives for a~~ Requirement R2, Criterion 1 and requires the Generator Owner ~~or Transmission Owner to demonstrate~~ identify any Element that trips due to a power swing condition (stable or unstable) in an actual event. This standard does not focus on the review of Protection Systems ~~on identified Elements are not~~ because they are covered by other NERC Reliability Standards. When a review of the Generator Owner’s Protection System reveals that tripping occurred due to a power swing, it is required to identify the Element and to notify its Planning Coordinator. Notifying the Planning Coordinator of the Element ensures that the planner is aware of an Element that was susceptible to ~~tripping in response to a power swing.~~ The Planning Coordinator will continue to notify entities of the identified Element under Requirement R1 unless the Planning Coordinator determines the Element is no longer susceptible to power swings ~~meeting~~.

### Requirement R4

Requirement R4 requires the Generator Owner and Transmission Owner to evaluate its load-responsive protective relays applied at all of the terminals of an identified Element to ensure that load-responsive protective relays are expected to not trip in response to stable power swings during non-Fault conditions. A method is provided within the standard to support consistent evaluation by Generator Owners and Transmission Owners based on specified conditions. ~~It also provides alternatives for the Once a~~ Generator Owner or Transmission Owner ~~to obtain agreement from its Planning Coordinator, Reliability Coordinator, and Transmission Planner that~~

~~an existing or modified Protection System is acceptable when providing security is notified of Elements pursuant to Requirement R1, or once a Generator Owner or Transmission Owner identifies an Element pursuant to Requirement R2 or R3, it has 12 full calendar months to evaluate each Element's load-responsive protective relays based on the PRC-026-1 – Attachment B, Criteria A and B if the evaluation hasn't been performed in the last three calendar years.~~

### **Information Common to Both Generation and Transmission Elements**

~~The PRC-026-1 – Attachment A lists the load-responsive protective relays that are subject to this standard. Generator Owners and Transmission Owners may own load-responsive protective relays (i.e. distance relays) that directly affect generation or transmission BES Elements and will require analysis as a result of Elements being identified by Requirements R1, R2 or R3. For example, distance relays owned by the Transmission Owner may be installed at the high-voltage side of the generator step-up (GSU) transformer (directional toward the generator) providing backup to generation protection. Generator Owners may have distance relays applied for back-up transmission protection or back-up protection for the GSU transformer. The Generator Owner may have relays installed at the generator terminals or the high-voltage side of the GSU transformer.~~

### **Exclusion of Time Based Load-Responsive Protective Relays**

~~The purpose of the standard is “To ensure that load-responsive protective relays are expected to not trip in response to stable power swings during non-Fault conditions.” Load-responsive protective relays with high-speed tripping pose the highest risk of operating during a power swing. Because of this, high-speed tripping is included in the standard and others (Zone 2 and 3) with a time a delay of 15 cycles or greater are excluded. The time delay used for the specified conditions exclusion on some load-responsive protective relays is recommended based on 1) the minimum time delay these relays are set in practice, and 2) the maximum expected time that load-responsive protective relays would compromise dependable tripping be exposed to the stable swing based on a swing rate.~~

~~In order to establish a time delay that strikes a line between a high-risk load-responsive protective relay and one that has a time delay for faults or unstable power swing tripping, a sample of swing rates were calculated based on a stable power swing entering and leaving the impedance characteristic as shown in Table 1. For a relay impedance characteristic that has the swing entering and leaving beginning at 90 degrees with a termination at 120 before exiting the zone, calculation of the timer must be greater than the time the stable swing is inside the relay operate zone.~~

~~The first option in Requirement R3 allows the Generator Owner or Transmission Owner to evaluate Elements identified in Requirements R1 or R2 to determine if load-responsive protective relays at the terminals of each identified Element are susceptible to tripping in response to a stable power swing. Specific criteria and system conditions are provided to analyze the characteristic of the load-responsive protective relays of each Element.~~

~~The second option in Requirement R3 allows the Generator Owner or Transmission Owner to exclude protective relays if they are blocked from tripping by power swing blocking (PSB). If~~

## Application Guidelines

---

~~PSB is applied, it is expected that the relays were set in consultation with the Transmission Planner to verify maximum slip rates, so that proper PSB settings can be applied. It is expected that Elements utilizing PSB relays have been evaluated for susceptibility to tripping in response to stable power swings, and thus can be excluded.~~

~~The third option in Requirement R3 allows the Generator Owner or Transmission Owner to modify its Protection System to achieve the desired goal of reducing the likelihood of tripping on a stable power swing. The Generator Owner or Transmission Owner may achieve this goal by meeting the criterion used in the first option or by applying power swing blocking. Modifications to the Protection System could include revising settings or logic, or replacing the Protection System. A Corrective Action Plan (CAP) is employed to allow an entity the flexibility to identify the actions and timetable to make the necessary adjustments. A CAP allows for outage scheduling, time for design, procurement, and installation of new relaying or the application of new settings. The amount of detail regarding the listing of the actions required to make the necessary changes to the Protection System is left to the discretion and management of the entity.~~

~~The fourth option in Requirement R3 allows the Generator Owner or Transmission Owner for the situation where making the Protection System secure for stable power swings, either through modified settings or replacement, will either significantly decrease the dependability for tripping for faults within its zone of protection or for tripping for out of step conditions. To ensure the risks due to tripping for stable power swings are balanced against the risk due to the reduction in dependability, and that reasonable effort to find viable Protection System modifications has been made, the applicable Generator Owner and Transmission Owner must obtain agreement from the Planning Coordinator, Reliability Coordinator, and Transmission Planner that tripping for a stable power swing is acceptable. The entities may agree that the existing or modified Protection System design and settings are acceptable. This option allows for cases where the existing Protection System design and settings are not acceptable, but modifications that do not meet the criterion in the first option result in an acceptable balance between dependability and security. In these cases, a CAP is employed to allow an entity the flexibility to identify the actions and timetable to make the necessary adjustments. A CAP allows for outage scheduling, time for design, procurement, and installation of new relaying or the application of new settings. The amount of detail regarding the listing of the actions required to make the necessary changes to the Protection System is left to the discretion and management of the entity.~~

Eq. (1)      
$$\text{Zone time} > 2 \times \left( \frac{(120^\circ - \text{Angle of entry into the relay characteristic})}{\text{Slip Rate}} \right)$$

<u>Table 1. Swing Rates</u>	
<u>Zone Timer</u> <u>(Cycles)</u>	<u>Slip Rate</u> <u>(Hz)</u>
<u>10</u>	<u>1.00</u>
<u>15</u>	<u>0.67</u>
<u>20</u>	<u>0.50</u>
<u>30</u>	<u>0.33</u>

With a minimum zone timer of 15 cycles, the corresponding slip of the system is 0.67 Hz. This represents an approximation of a slow slip rate during a system Disturbance. This value corresponds to the typical minimum time delay used for zone 2 distance relays in transmission line protection. Longer time delays allow for slower slip rates.

### **Application to Transmission ~~Owners~~ Elements**

~~The criterion describes~~The criteria in PRC-026-1 – Attachment B describe a lens characteristic formed in the impedance (R-X) plane that connects the endpoints of the total system impedance together by varying the sending and receiving-end system voltages from 0.7 to 1.0 per unit, while maintaining a constant system separation angle across the total system impedance (with the parallel transfer impedance removed—see Figures 4 and 23 through 5). The total system impedance is derived from a two-bus equivalent network and is determined by summing the sending-end source impedance, the line impedance in parallel with(excluding the Thévenin~~Thevenin~~ equivalent transfer impedance), and the receiving-end source impedance (Figure 3). ~~This as shown in Figures 6 and 7.~~ The goal in establishing the total system source impedance is minimized to create/represent a conservative, worst case condition by including all transmission Elements that represent a condition that will maximize the security of the relay against various system conditions. The smallest total system impedance represents a condition where the size of the lens characteristic in the R-X plane is smallest and is a conservative operating point from the standpoint of ensuring a load responsive relay will not trip given a predetermined angular displacement between the sending- and receiving-end voltages. The smallest total system impedance results when all generation is in service and all transmission elements are modeled in their “normal” system configuration with generation set at the value reported to the Transmission Planner. Further, (PRC-026-1 – Attachment B, Criteria A). The parallel transfer impedance is removed to represent a likely condition where parallel elements may be lost during the disturbance, and the loss of these elements magnifies the sensitivity of the load-responsive relays on the parallel line by removing the “infeed effect” (i.e., the apparent impedance sensed by the relay is decreased as a result of the loss of the transfer impedance, thus making the relay more likely to trip for a stable power swing).

## Application Guidelines

The sending- and receiving-end source voltages are varied from 0.7 to 1.0 per unit to form a portion of a lens characteristic instead of varying the voltages from 0 to 1.0 per unit, which would form a full-lens characteristic. The ratio of these two voltages is used in the calculation of the portion of the lens, and result in a ratio range from 0.7 to 1.43.

$$\text{Eq. (2)} \quad \frac{E_S}{E_R} = \frac{0.7}{1.0} = 0.7$$

$$\text{Eq. (3):} \quad \frac{E_R}{E_S} = \frac{1.0}{0.7} = 1.43$$

The internal generator voltage during severe power swings or transmission system fault conditions will be greater than zero, due to voltage regulator support. The voltage ratio of 0.7 to 1.43 is chosen to be more conservative than the PRC-023 and PRC-025 NERC Reliability Standards, where a lower bound voltage of 0.85 per unit voltage is used. A plus and minus 15% internal generator voltage range was chosen as a conservative voltage range for calculation of the voltage ratio that would determine the end points of the portion of the lens. For example, the voltage ratio using these voltages would result in a ratio range from 0.739 to 1.353.

$$\text{Eq. (4)} \quad \frac{E_S}{E_R} = \frac{0.85}{1.15} = 0.739$$

$$\text{Eq. (5):} \quad \frac{E_R}{E_S} = \frac{1.15}{0.85} = 1.353$$

The lower ratio is rounded down to 0.7 to be more conservative, allowing a voltage range of 0.7 to 1.0 per unit to be used for the calculation of the lens end points.<sup>9</sup>

When the parallel transfer impedance is included in the model, the split in current through the parallel transfer impedance path results in actual measured relay impedances that are larger than those measured when the parallel transfer impedance is removed (i.e., infeed effect), which would make it more likely for an impedance relay element to be completely contained within the applicable portion of the lens characteristic in Figure 11. If the transfer impedance is included in the lens evaluation, a distance relay element could be deemed as meeting PRC-026-1 – Attachment B and, in fact would be secure, assuming all elements were in their normal state. In this case, it could trip for a stable power swing during an actual event if the system was weakened (i.e., a higher transfer impedance) by the loss of a subset of lines that make up the parallel transfer impedance. This could happen because those parallel lines tripped on unstable swings, contained the initiating fault, and/or were lost due to operation of breaker failure or remote back-up protection schemes in Figure 10.

Either the saturated transient or sub-transient direct axis reactance values may be used for machines in the evaluation because they are smaller than un-saturated reactance values. Since, sub-transient saturated generator reactances are ~~used since they are~~ smaller than the transient or synchronous reactances, ~~and reactance, they~~ result in a smaller source impedance and a smaller separation angle lens characteristic in the graphical analysis (~~Figures 4 and 5~~ as shown in Figures

---

<sup>9</sup> Final Report on the August 14, 2003 Blackout in the United States and Canada: Causes and Recommendations, April 2004, Section 6 (The Cascade Stage of the Blackout), p. 94 under “Why the Generators Tripped Off,” states, “Some generator undervoltage relays were set to trip at or above 90% voltage. However, a motor stalls out at about 70% voltage and a motor starter contactor drops out around 75%, so if there is a compelling need to protect the turbine from the system the under-voltage trigger point should be no higher than 80%.”

## Application Guidelines

---

8 and 9. Since power swings occur in a time frame where generator transient reactances will be prevalent, it is acceptable to use saturated transient reactances instead of saturated sub-transient reactance values. Some short-circuit models may not include transient reactance values, so in this case, the use of sub-transient is acceptable because it also produces more conservative results than transient reactances. For this reason, either value is acceptable when determining the system source impedances (PRC-026-1 – Attachment B, Criteria A and B, No. 3).

Saturated reactance values are also the values used in short-circuit programs that produce the system impedance mentioned above. Planning and stability software generally use the unsaturated reactance values. Generator models used in transient stability analyses recognize that the extent of the saturation effect depends upon both rotor (field) and stator currents. Accordingly, they derive the effective saturated parameters of the machine at each instant by internal calculation from the specified (constant) unsaturated values of machine reactances and the instantaneous internal flux level. The specific assumptions regarding which inductances are affected by saturation, and the relative effect of that saturation, are different for the various generator models used. Thus, unsaturated values of all machine reactances are used in setting up planning and stability software data, and the appropriate set of open-circuit magnetization curve data is provided for each machine.

The source or system equivalent impedances can be obtained by a number of different methods using commercially available short-circuit calculation tools.<sup>10</sup> Most short-circuit tools have a network reduction feature that allows the user to select the local and remote terminal buses to retain. The first method reduces the system to one that contains two buses, an equivalent generator at each bus (representing the source impedance at the sending- and receiving-ends), and two parallel lines; one being the line impedance of the protected line with relays being analyzed, the other being the transfer impedance representing all other combinations of lines that connect the two buses together (in Figure 3)-6. Another conservative method is to open both ends of the line in question, and apply a three-phase bolted fault at each bus. The resulting source impedance at each end will be less than or equal to the actual source impedance calculated by the network reduction method. Either method can be used to develop the system source impedances at both ends.

The ~~first~~ two bullets of ~~criterion~~ PRC-026-1 – Attachment B, Criteria A, No. 1, identify the system separation angles to ~~be used to~~ identify the ~~shape and~~ size of the power swing stability boundary to be used to test load-responsive impedance relay elements. Both bullets test impedance relay elements that are not supervised by power swing blocking. The first bullet of PRC-026-1 – Attachment B, Criteria A, No. 1 evaluates a system separation angle of at least 120 degrees that is held constant while varying the sending- and receiving-end source voltages from 0.7 to 1.0 per unit, thus creating a power swing stability boundary shaped like a portion of a lens about the total system impedance in Figure 3. This portion of a lens characteristic is compared to the tripping portion of the distance relay characteristic, that is, the portion that is not supervised by load encroachment ~~logic~~, blindings, or some other form of supervision as shown in Figure 12

---

<sup>10</sup> Demetrios A. Tziouvaras and Daqing Hou, Appendix in Out-Of-Step Protection Fundamentals and Advancements, by Demetrios A. Tziouvaras and Daqing Hou, available at (April 17, 2014; <https://www.selinc.com>).



## Application Guidelines

---

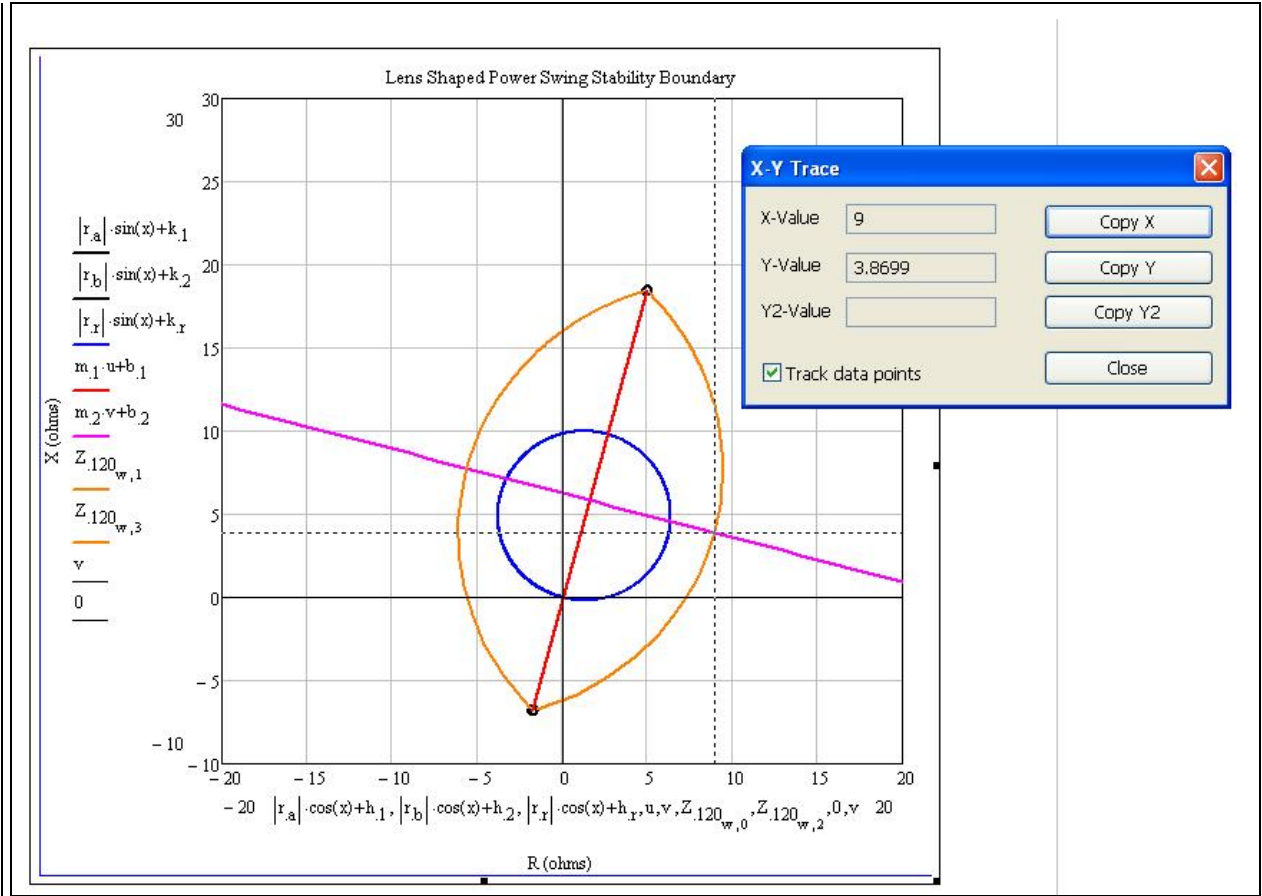
that restricts the distance element from tripping for heavy, balanced load conditions. ~~If the tripping portion of~~ the impedance characteristics are completely contained within the ~~portion of a~~ lens characteristic, the Element ~~passes the evaluation (Figures 6 and 7).~~~~meets Criteria A in PRC-026-1 – Attachment B.~~ A system separation angle of 120 degrees was chosen for the evaluation where PSB is not applied because it is generally accepted in the industry that recovery for a swing beyond this angle is unlikely to occur.<sup>11</sup>

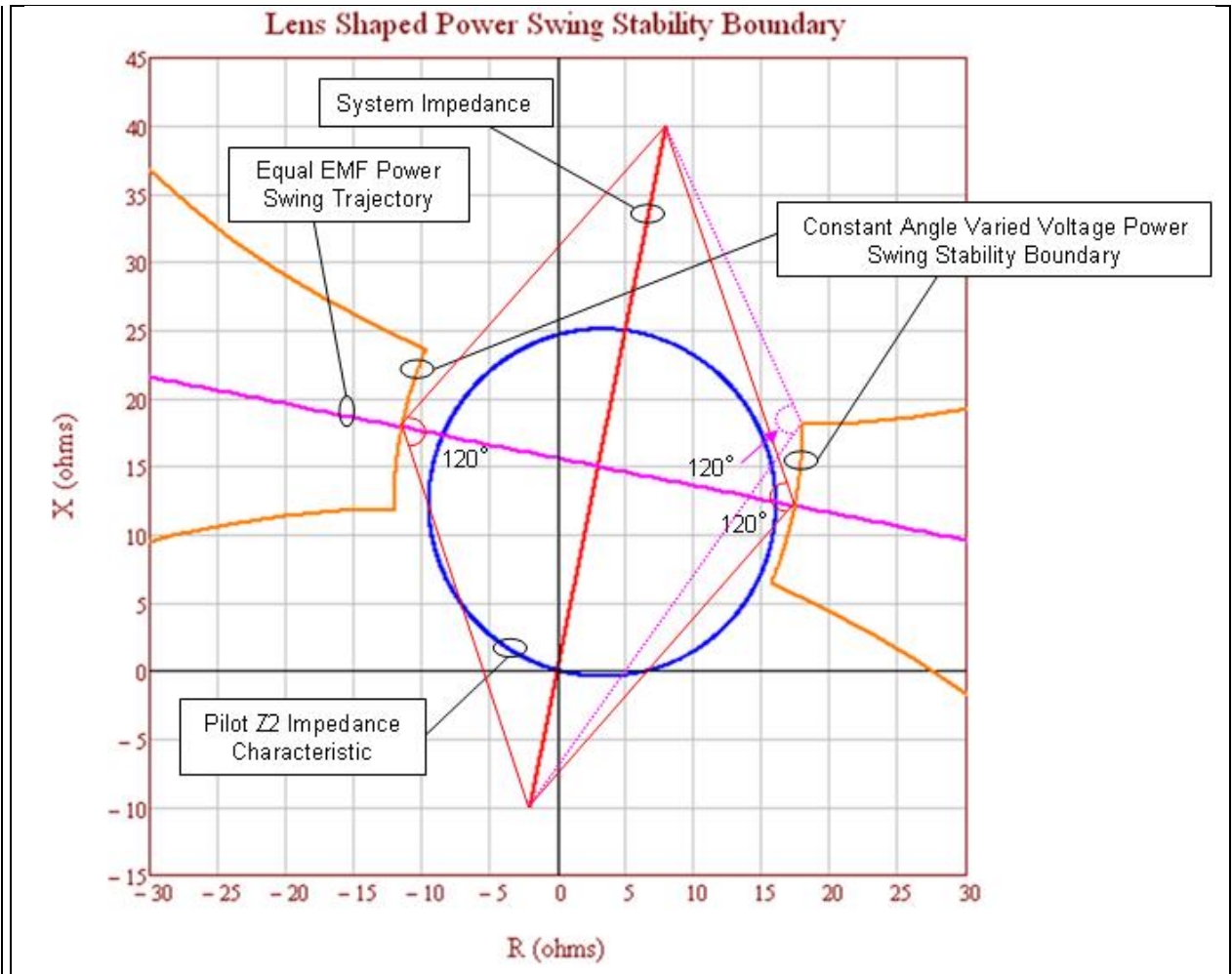
The second bullet ~~of PRC-026-1 – Attachment B, Criteria A, No. 1~~ evaluates impedance relay elements at a system separation angle of less than 120 degrees, similar to the first ~~riterion~~ bullet described above. ~~The An angle evaluated must less than 120 degrees may be agreed upon by used if a documented stability analysis demonstrates that the Planning Coordinator, Reliability Coordinator, and Transmission Planner, and tripping of the distance elements for stable power swings should not occur swing becomes unstable at this angle, as shown by a system planning or operating studies separation angle of less than 120 degrees.~~

---

<sup>11</sup> “The critical angle for maintaining stability will vary depending on the contingency and the system condition at the time the contingency occurs; however, the likelihood of recovering from a swing that exceeds 120 degrees is marginal and 120 degrees is generally accepted as an appropriate basis for setting out-of-step protection. Given the importance of separating unstable systems, defining 120 degrees as the critical angle is appropriate to achieve a proper balance between dependable tripping for unstable power swings and secure operation for stable power swings.” ~~NERC System Protection and Control Subcommittee, Protection System Response to Power Swings, August 2013: [http://www.nerc.com/comm/PC/System%20Protection%20and%20Control%20Subcommittee%20SPCS%2020/SPCS%20Power%20Swing%20Report\\_Final\\_20131015.pdf](http://www.nerc.com/comm/PC/System%20Protection%20and%20Control%20Subcommittee%20SPCS%2020/SPCS%20Power%20Swing%20Report_Final_20131015.pdf)~~ ~~PSRPS Report at p. 28.~~, p. 28.

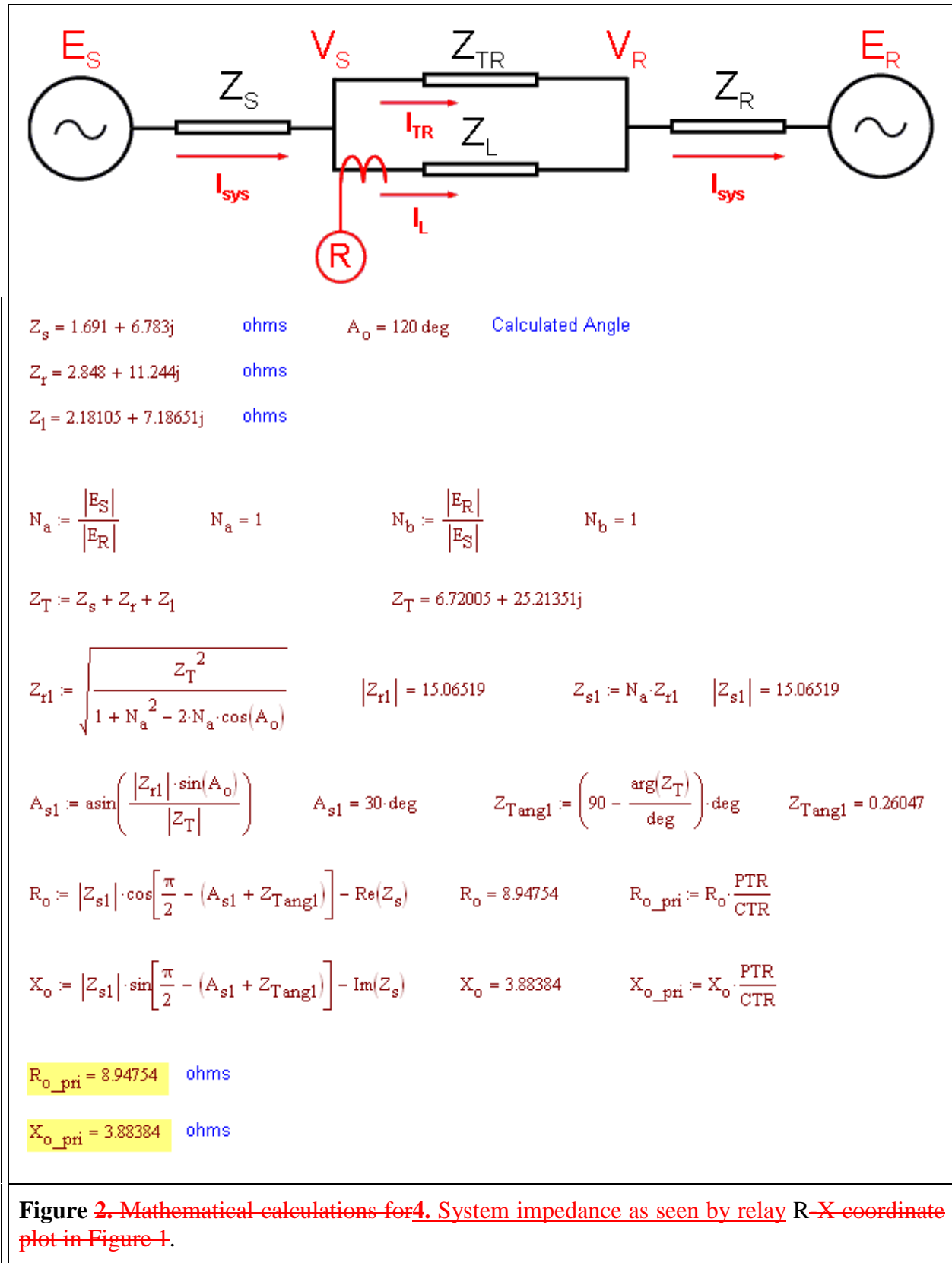
# Application Guidelines



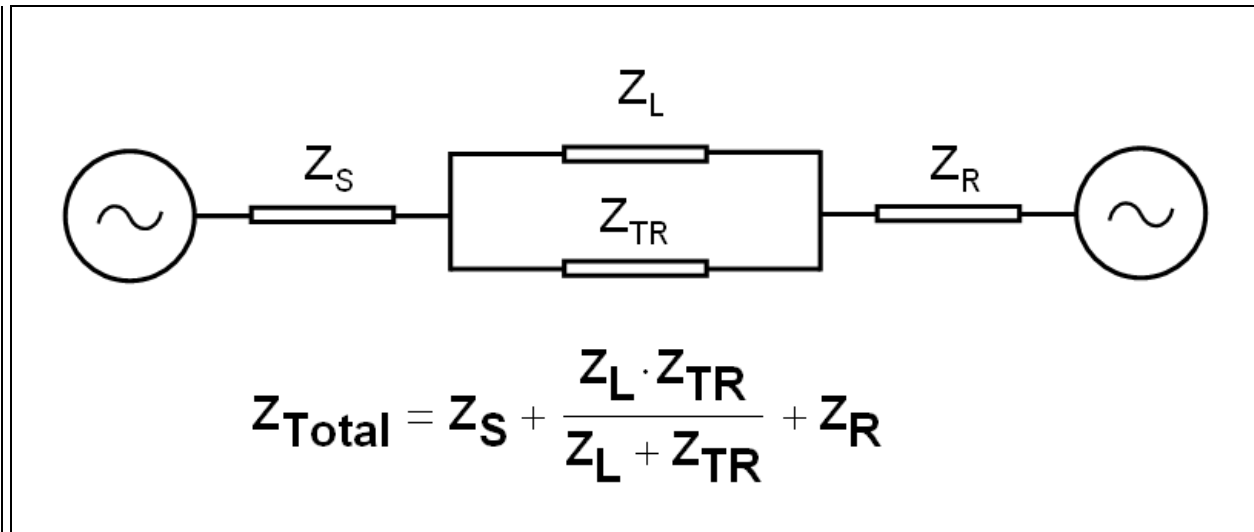


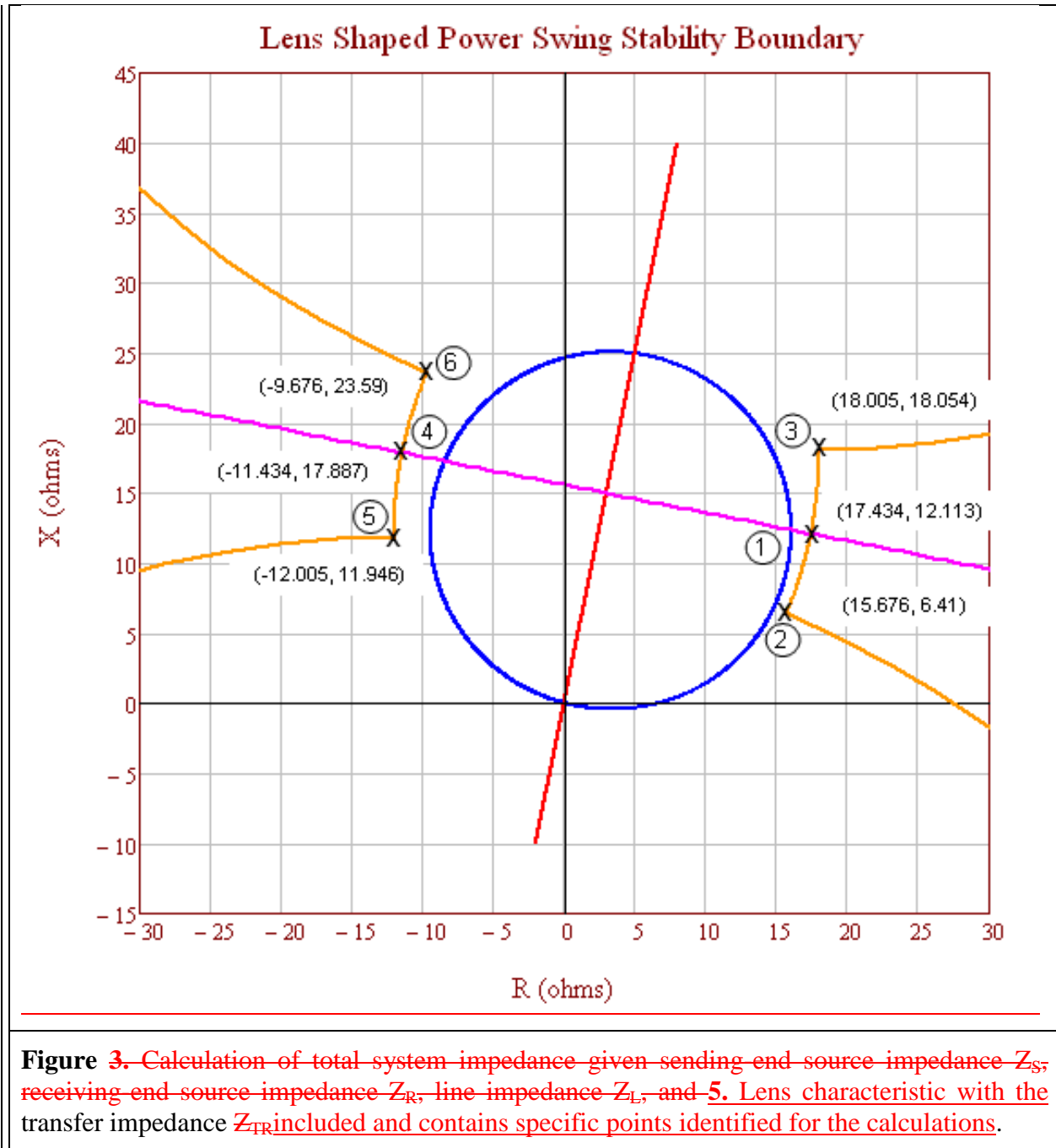
**Figure 1.** Graphical output showing the plotted R-X coordinates of the calculated lens characteristic (orange plot) with a constant angle of 120 degrees and varying source voltages. The equal EMF ( $V_S = V_R$ , where  $N = V_S / V_R = 1$ ) coordinate is shown. **Figure 3.** The portion of the lens characteristic that is formed in the impedance (R-X) plane. The pilot zone 2 relay is completely contained within the portion of the lens (e.g., it does not intersect any portion of the partial lens), therefore it complies with PRC-026-1 – Attachment B, Criteria A, No. 1.

## Application Guidelines

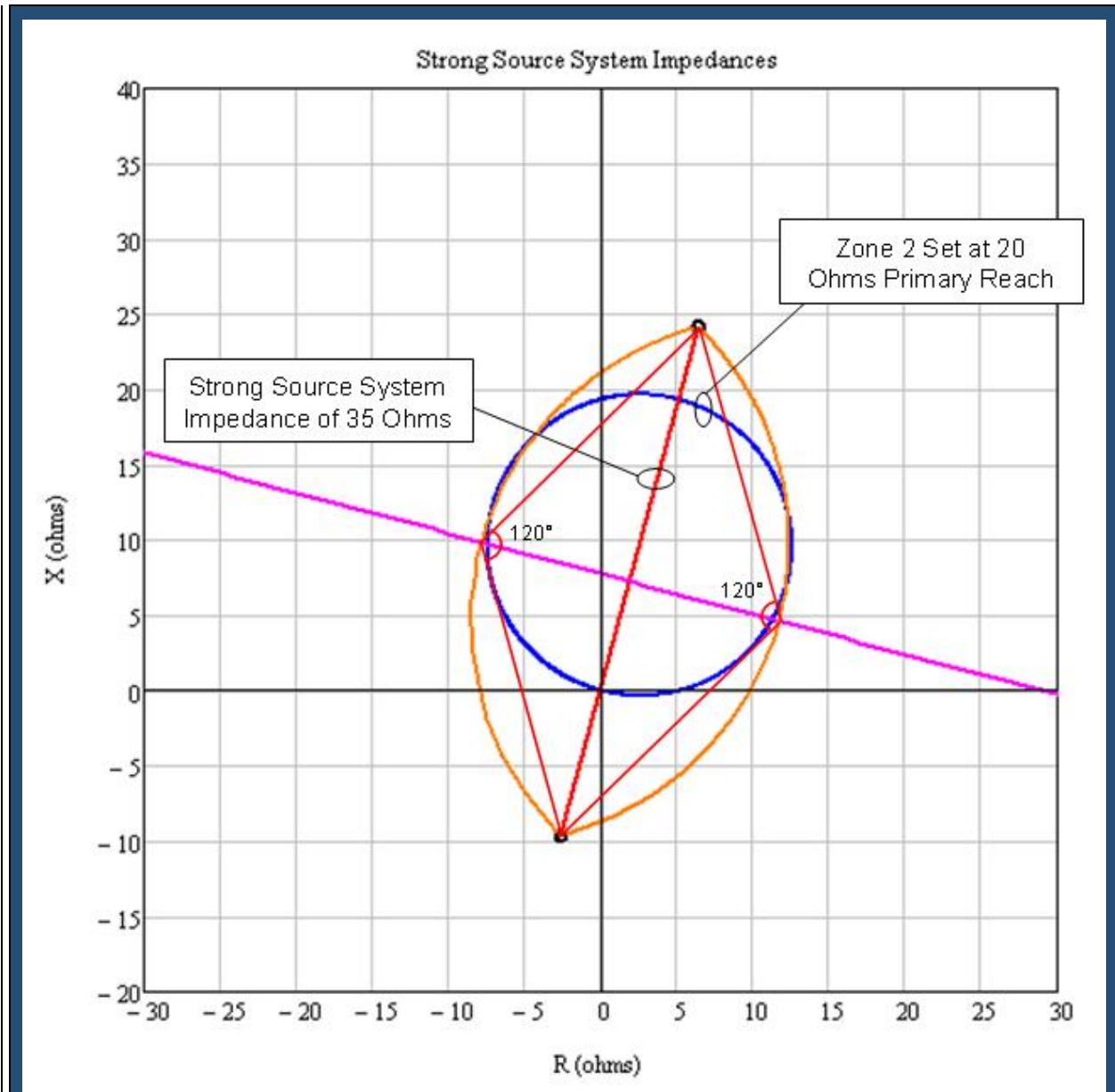








**Figure 3.** Calculation of total system impedance given sending end source impedance  $Z_S$ , receiving end source impedance  $Z_R$ , line impedance  $Z_L$ , and  $Z_{TR}$  included and contains specific points identified for the calculations.

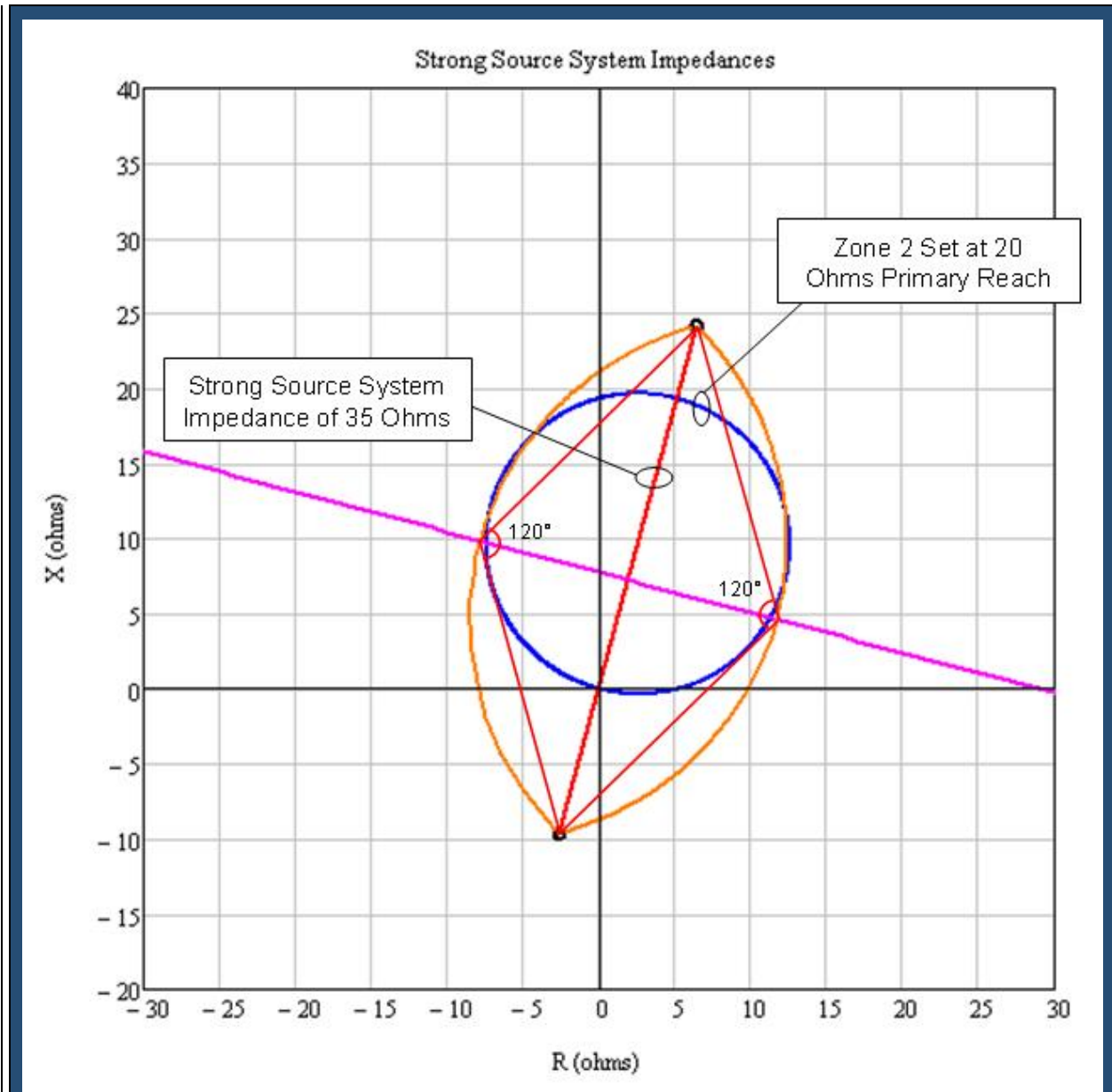


**Table 2. Example Calculation (Lens Point 1)**

**Figure 4.** A strong source system with a line impedance of  $Z_{Line} = 16$  ohms is shown. This represents a heavily-loaded system, using a maximum generation profile and using generator sub-transient reactance. The zone 2 mho circle (set at 125% of  $Z_{Line}$ ) extends into the power swing stability boundary (orange lens characteristic). Using the strongest source system is more conservative because it shrinks the power swing stability boundary, bringing it closer to the mho circle. This example is for calculating the impedance the first point of the lens characteristic. Equal source voltages are used for the 230 kV (base) line with the sending voltage ( $E_S$ ) leading the receiving voltage ( $E_R$ ) by 120 degrees. See Figures 4 and 5.

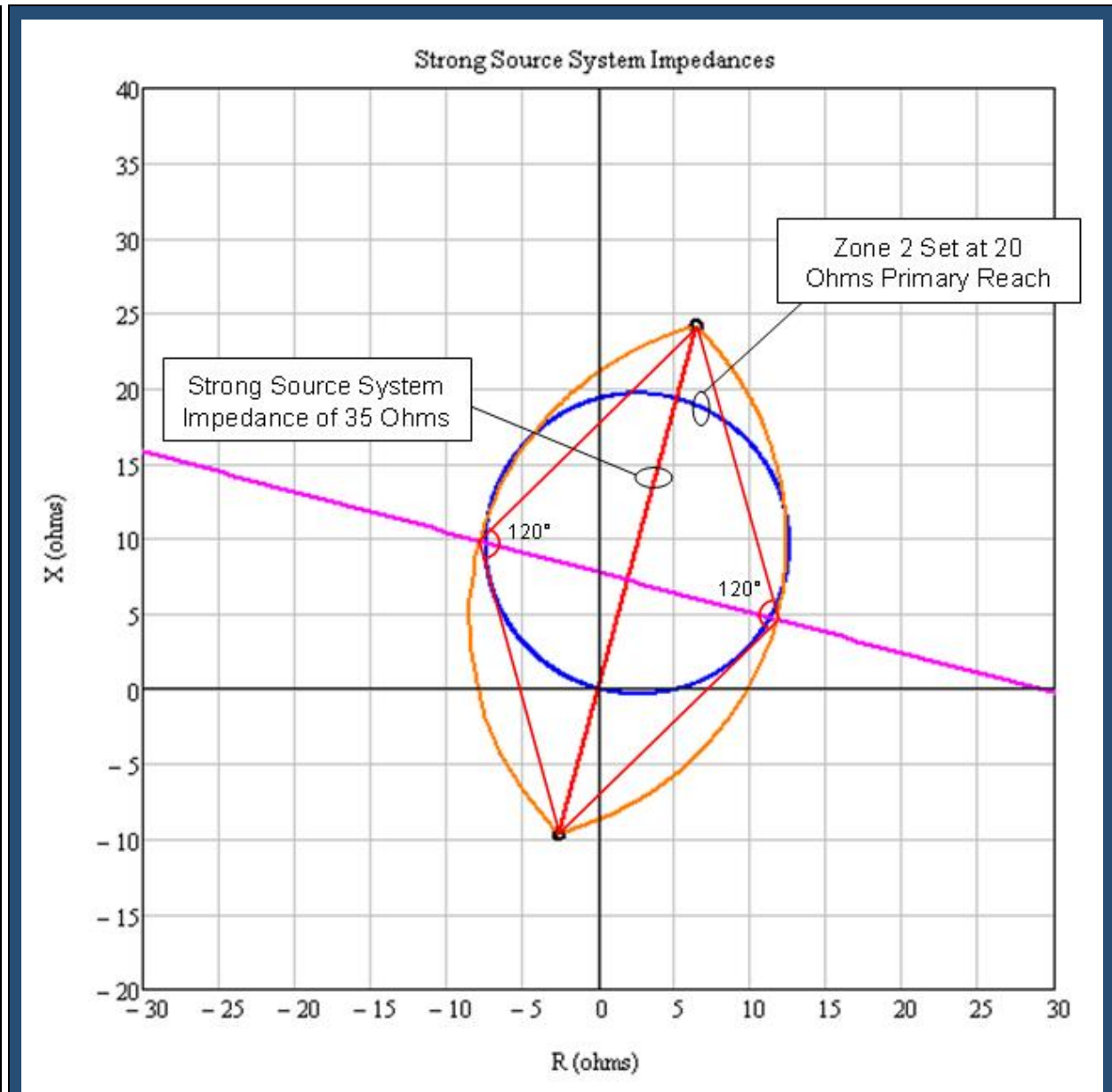
<u>Eq. (6)</u>	$E_S = \frac{V_{LL} \angle 120^\circ}{\sqrt{3}}$
----------------	--------------------------------------------------





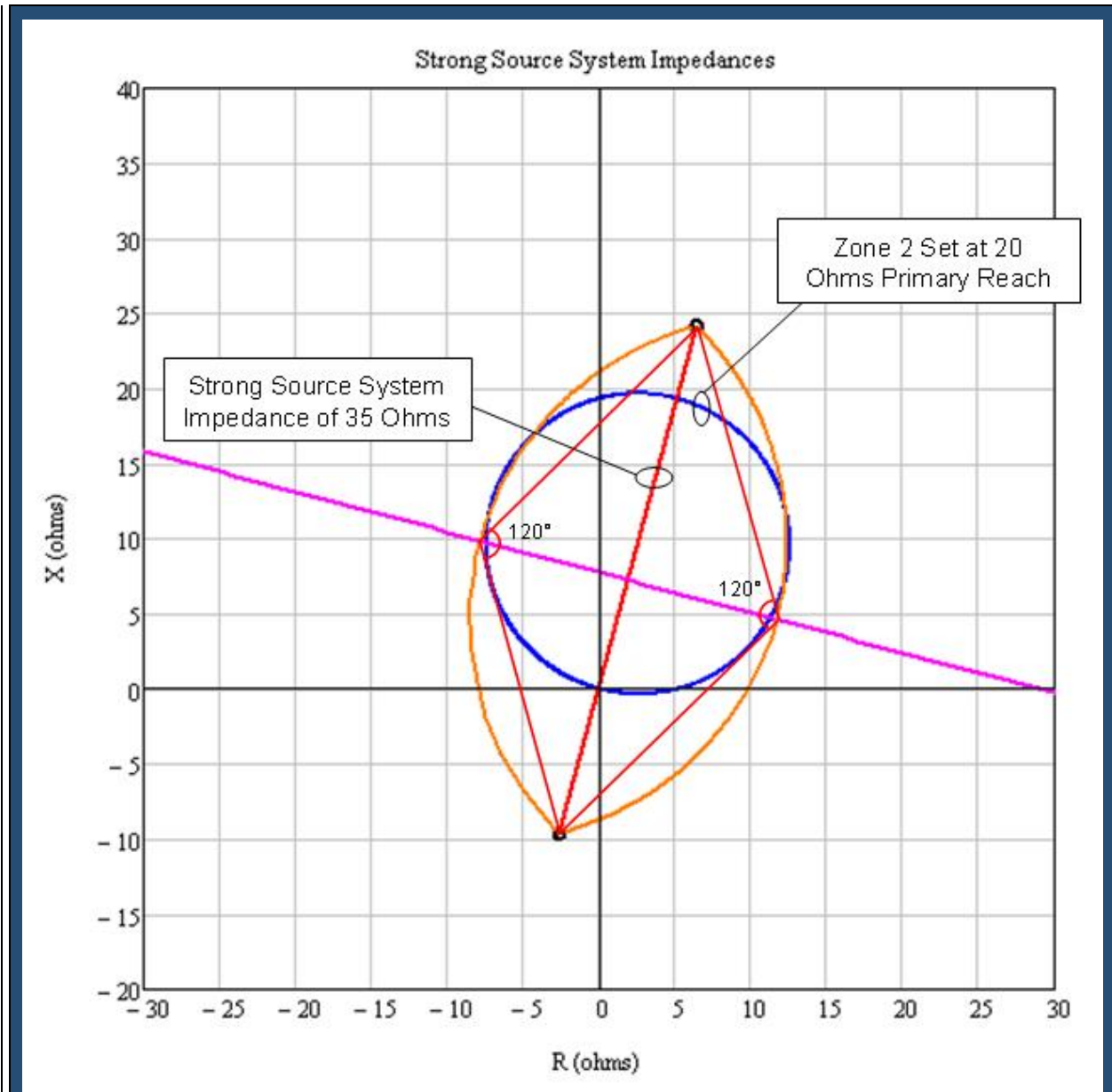
**Table 2. Example Calculation (Lens Point 1)**

	$E_S = \frac{230,000 \angle 120^\circ V}{\sqrt{3}}$
	$E_S = 132,791 \angle 120^\circ V$
Eq. (7)	$E_R = \frac{V_{LL} \angle 0^\circ}{\sqrt{3}}$
	$E_R = \frac{230,000 \angle 0^\circ V}{\sqrt{3}}$



**Table 2. Example Calculation (Lens Point 1)**

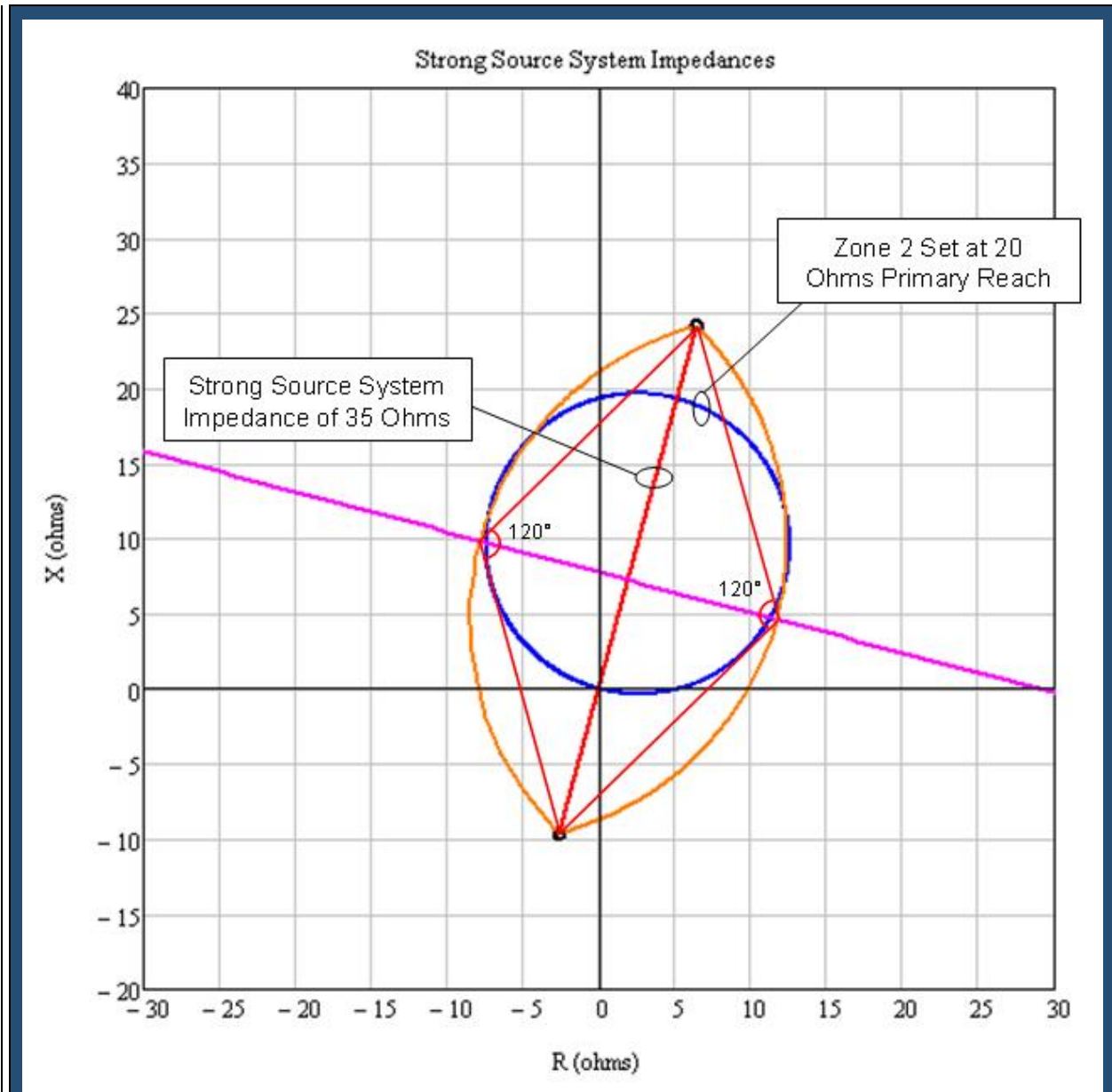
	$E_R = 132,791 \angle 0^\circ V$		
Given positive sequence impedance data (The transfer impedance $Z_{TR}$ is set to infinity).			
<u>Given:</u>	$Z_S = 2 + j10 \Omega$	$Z_L = 4 + j20 \Omega$	$Z_R = 4 + j20 \Omega$
<u>Given:</u>	$Z_{TR} = Z_L \times 10^{10} \Omega$		



**Table 2. Example Calculation (Lens Point 1)**

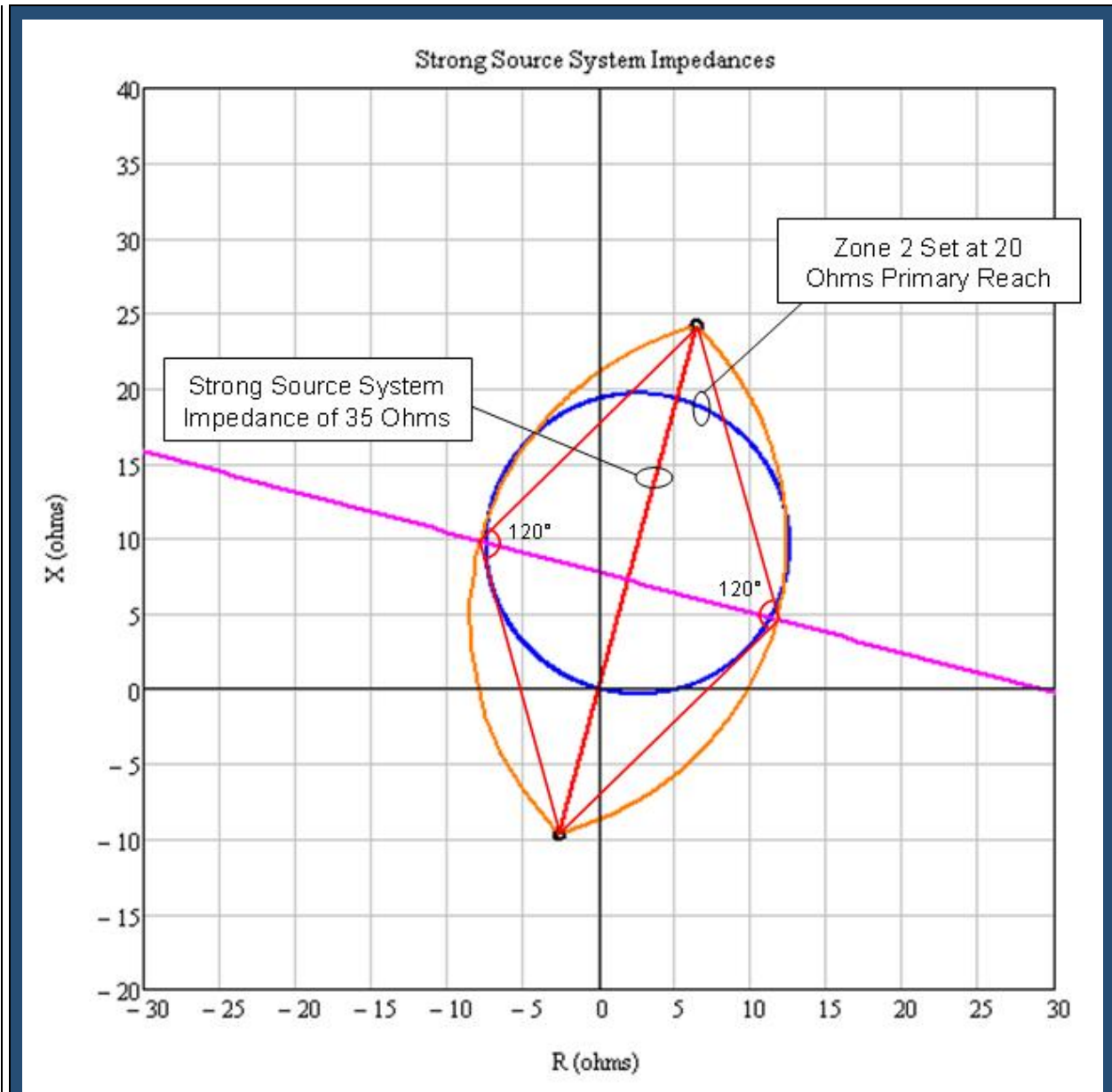
Total impedance between generators.

Eq. (8)	$Z_{total} = \frac{(Z_L \times Z_{TR})}{(Z_L + Z_{TR})}$
	$Z_{total} = \frac{((4 + j20) \Omega \times (4 + j20)^{10} \Omega)}{((4 + j20) \Omega + (4 + j20)^{10} \Omega)}$
	$Z_{total} = 4 + j20 \Omega$



**Table 2. Example Calculation (Lens Point 1)**

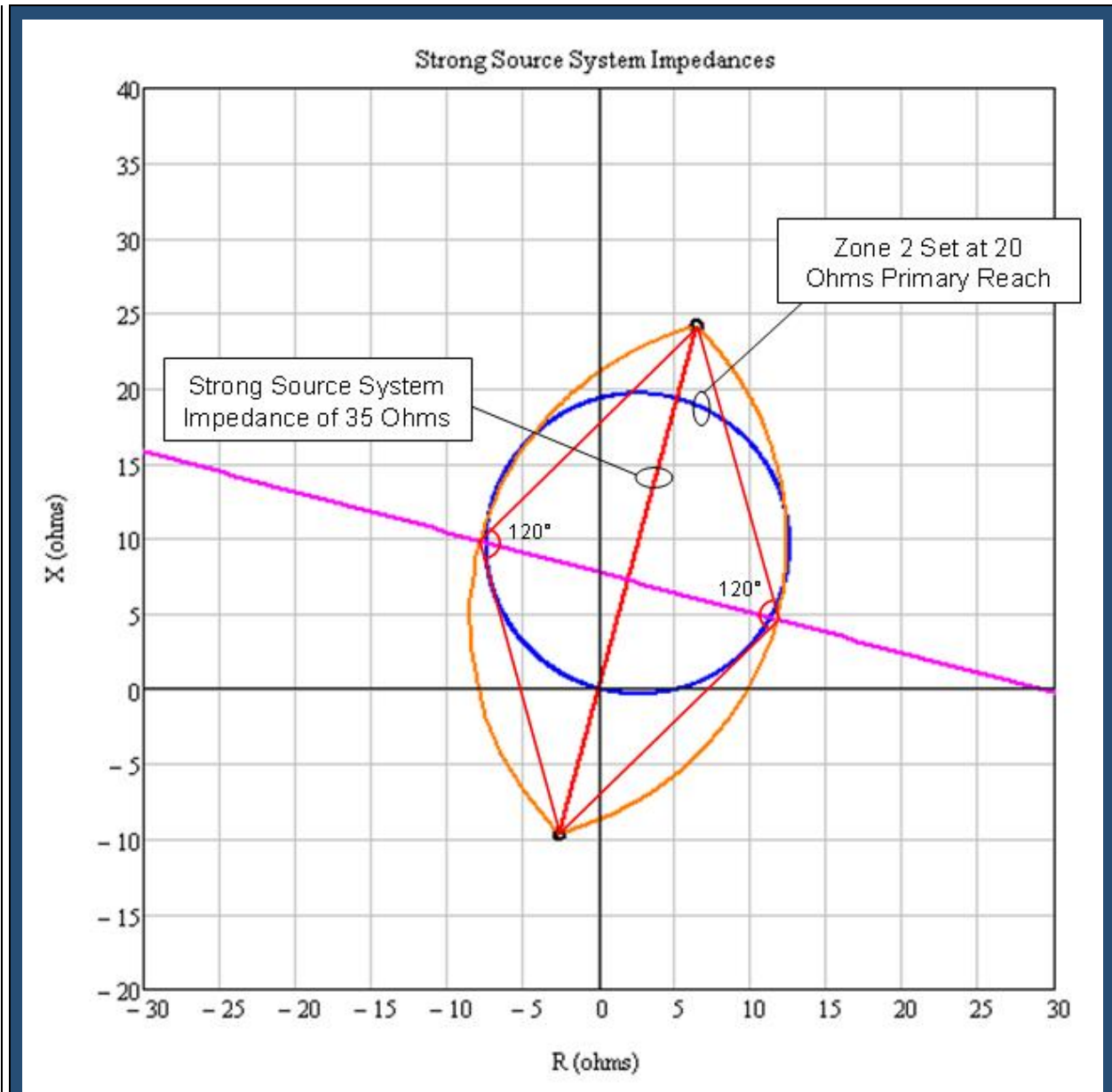
<u>Total system impedance.</u>	
<u>Eq. (9)</u>	$Z_{sys} = Z_S + Z_{total} + Z_R$
	$Z_{sys} = (2 + j10) \Omega + (4 + j20) \Omega + (4 + j20) \Omega$
	$Z_{sys} = 10 + j50 \Omega$



**Table 2. Example Calculation (Lens Point 1)**

Total system current from sending source.

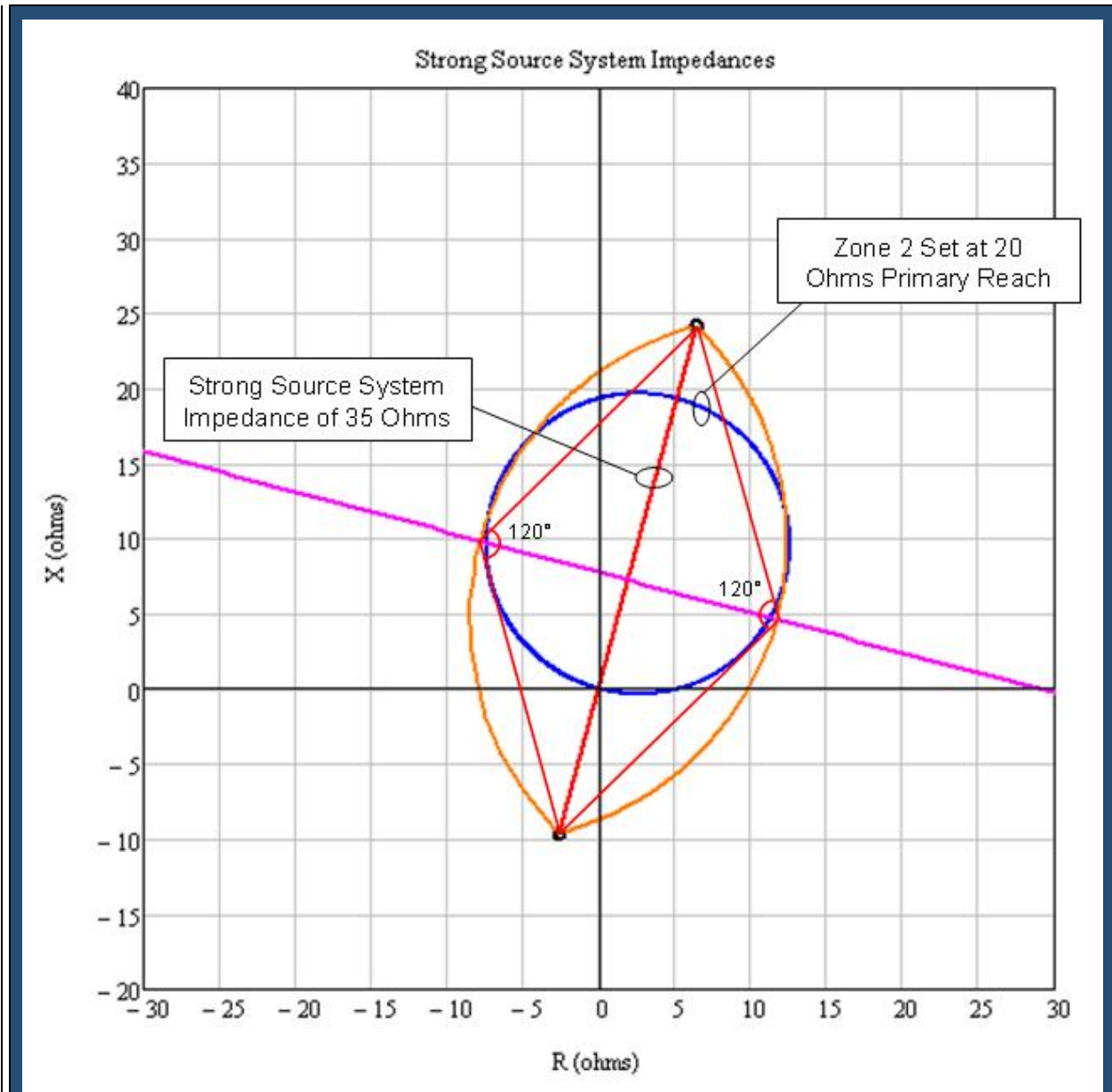
<u>Eq. (10)</u>	$I_{sys} = \frac{E_S - E_R}{Z_{sys}}$
	$I_{sys} = \frac{132,791 \angle 120^\circ V - 132,791 \angle 0^\circ V}{(10 + j50) \Omega}$
	$I_{sys} = 4,511 \angle 71.3^\circ A$



**Table 2. Example Calculation (Lens Point 1)**

The current as measured by the relay on  $Z_L$  is only the current flowing through that line as determined by using the current divider equation.

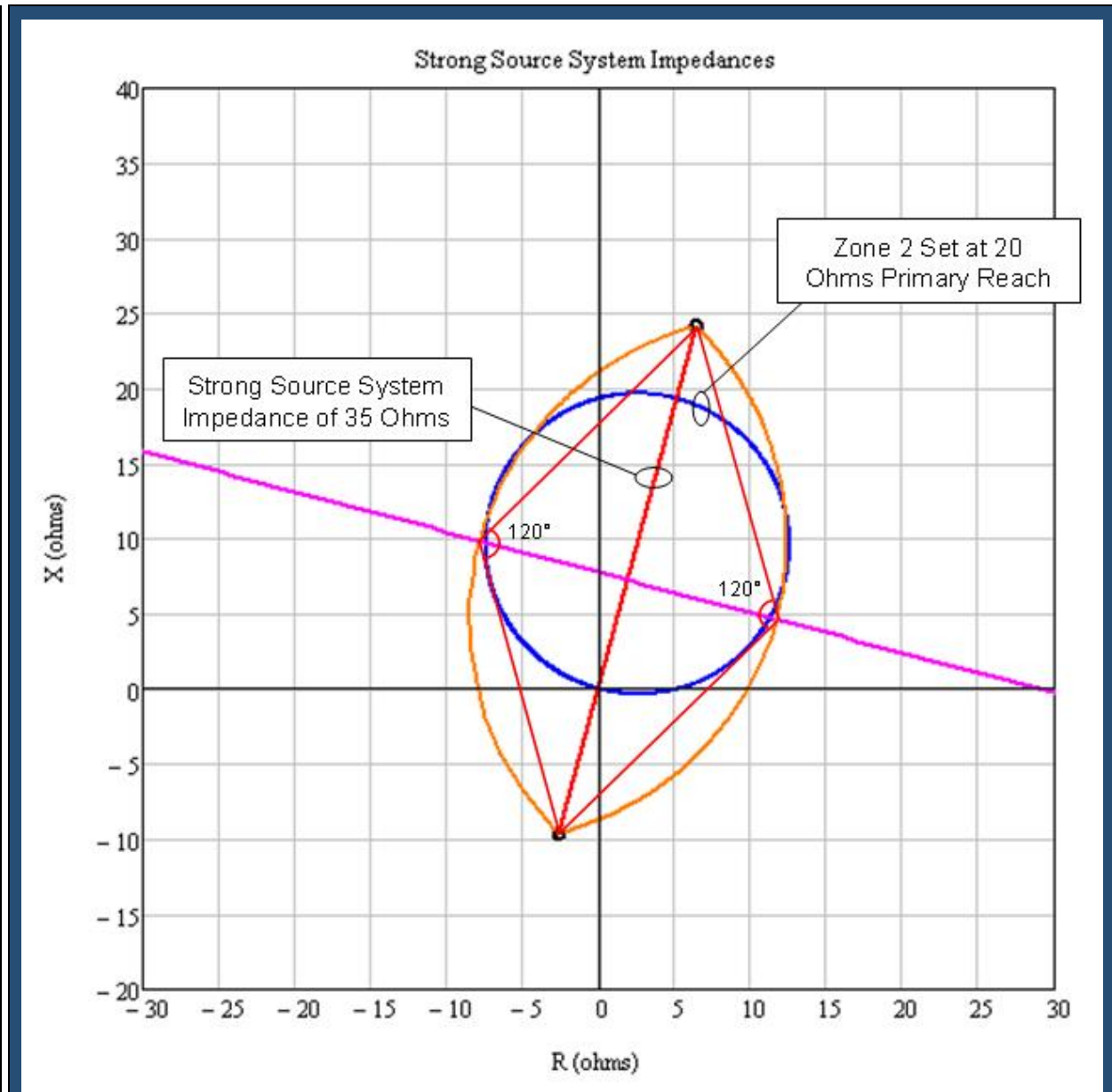
Eq. (11)	$I_L = I_{sys} \times \frac{Z_{TR}}{Z_L + Z_{TR}}$
	$I_L = 4,511 \angle 71.3^\circ A \times \frac{(4 + j20)^{10} \Omega}{(4 + j20) \Omega + (4 + j20)^{10} \Omega}$
	$I_L = 4,511 \angle 71.3^\circ A$



**Table 2. Example Calculation (Lens Point 1)**

The voltage as measured by the relay on  $Z_L$  is the voltage drop from the sending source through the sending source impedance.

Eq. (12)	$V_S = E_S - (Z_S \times I_{sys})$
	$V_S = 132,791 \angle 120^\circ V - [(2 + j10) \Omega \times 4,511 \angle 71.3^\circ A]$
	$V_S = 95,757 \angle 106.1^\circ V$

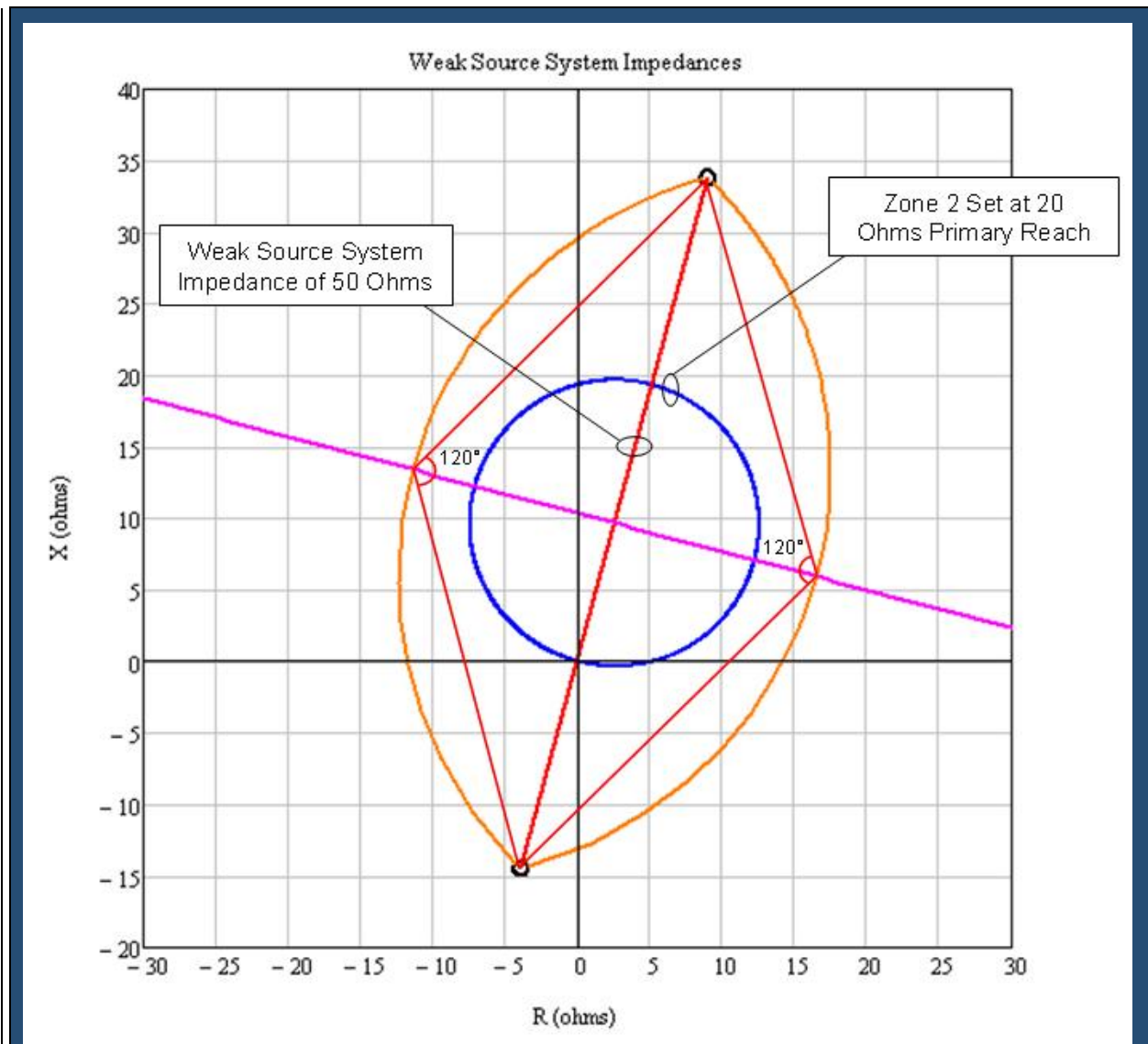


**Table 2. Example Calculation (Lens Point 1)**

The impedance seen by the relay on  $Z_L$ .

Eq. (13)	$Z_{L-Relay} = \frac{V_S}{I_L}$
	$Z_{L-Relay} = \frac{95,757 \angle 106.1^\circ V}{4,511 \angle 71.3^\circ A}$
	$Z_{L-Relay} = 17.434 + j12.113 \Omega$





**Table 3. Example Calculation (Lens Point 2)**

**Figure 5.** A weak-source system with a line impedance of  $Z_{Line} = 16$  ohms is shown. This represents a lightly-loaded system, using a minimum-generation profile and/or using generator transient reactance instead of using generator sub-transient reactance. The zone 2 mho circle (set at 125% of  $Z_{Line}$ ) does not extend into the power swing stability boundary (orange lens characteristic). Using a weaker source system expands the power swing stability boundary away from the mho circle. This example is for calculating the impedance second point of the lens characteristic. Unequal source voltages are used for the 230 kV (base) line with the sending voltage ( $E_S$ ) at 70% of the receiving voltage ( $E_R$ ) and leading the receiving voltage by 120 degrees. See Figures 4 and 5.

Eq. (14) 
$$E_S = \frac{V_{LL} \angle 120^\circ}{\sqrt{3}} \times 70\%$$

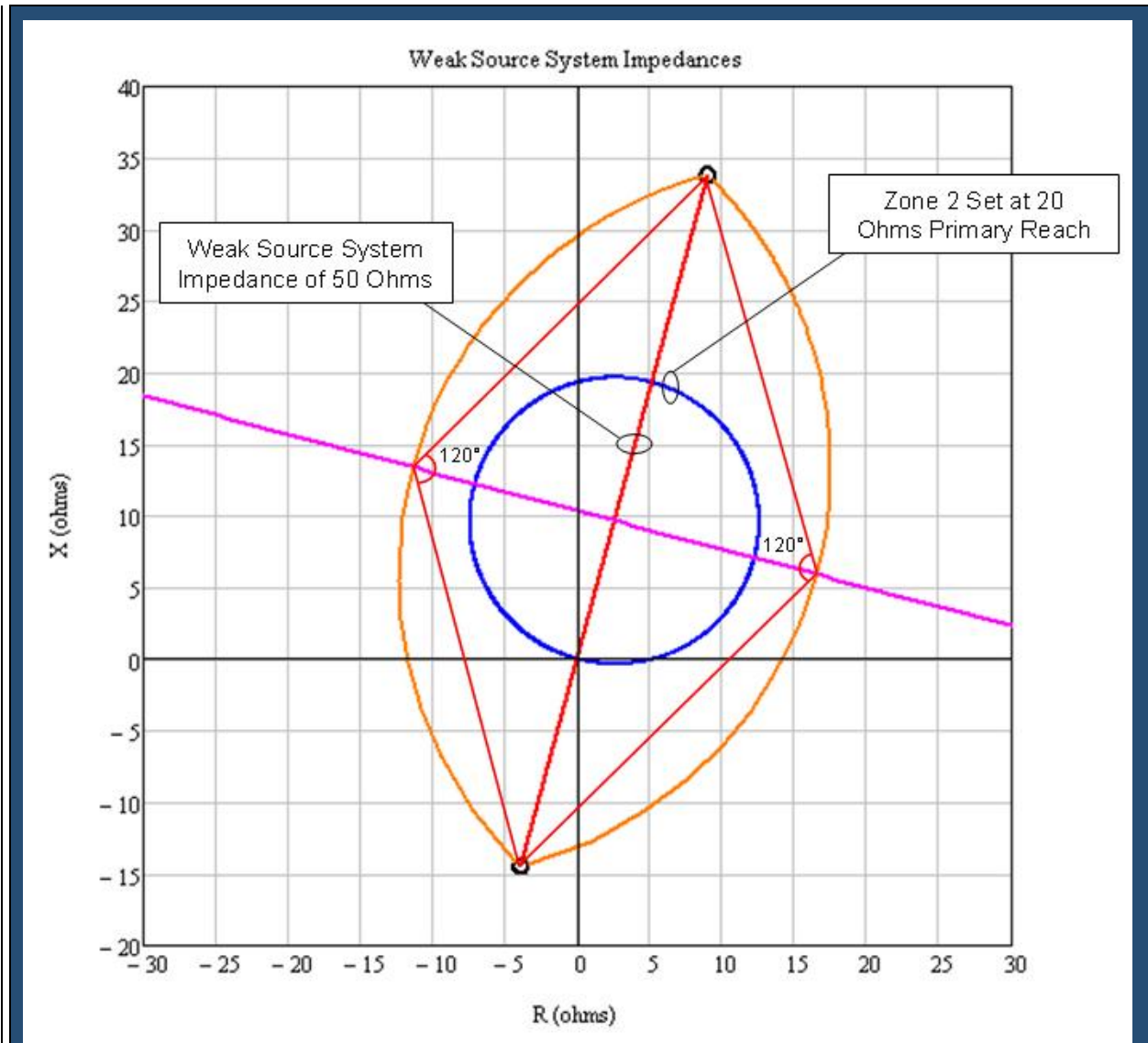
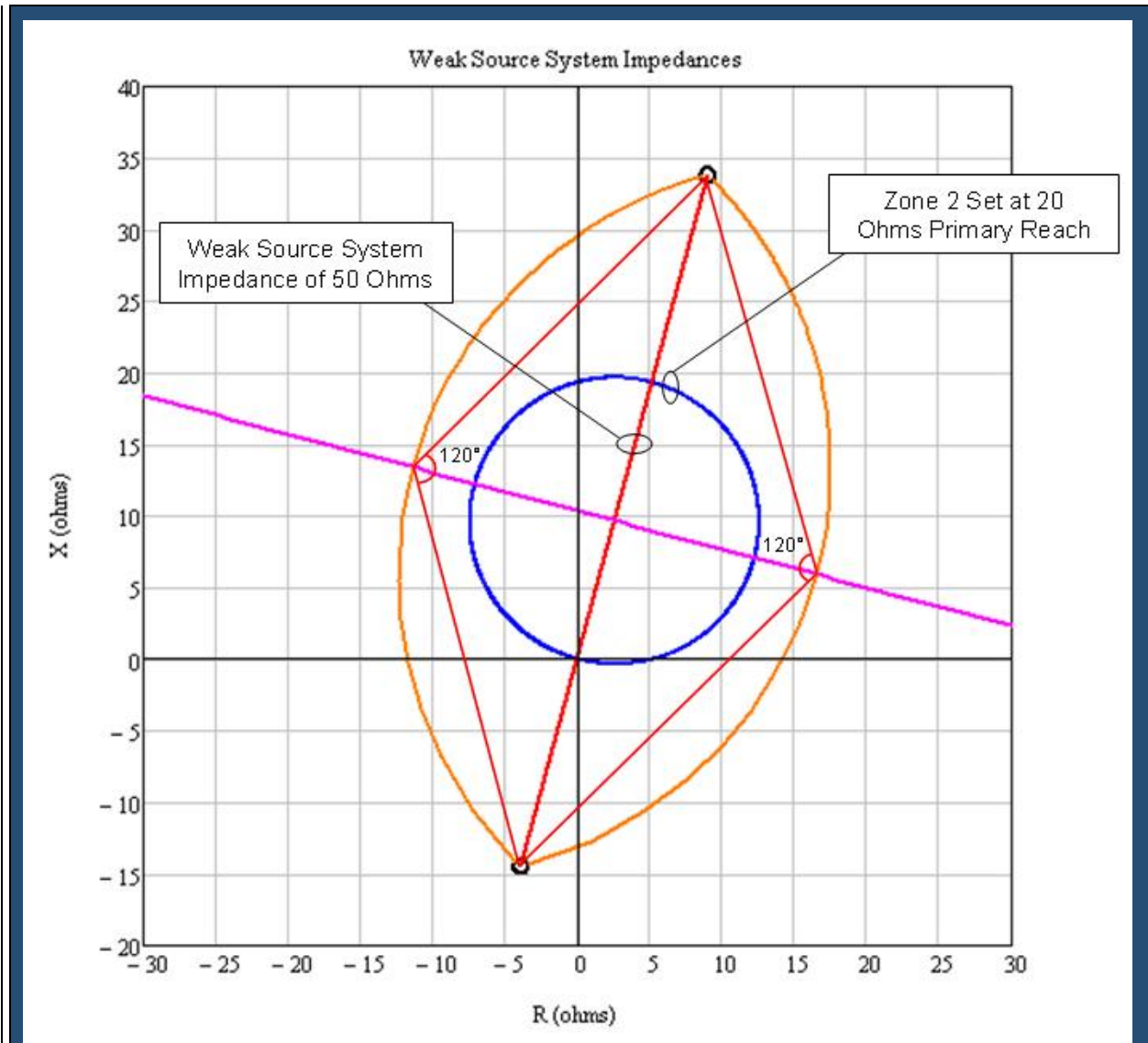


Table 3. Example Calculation (Lens Point 2)

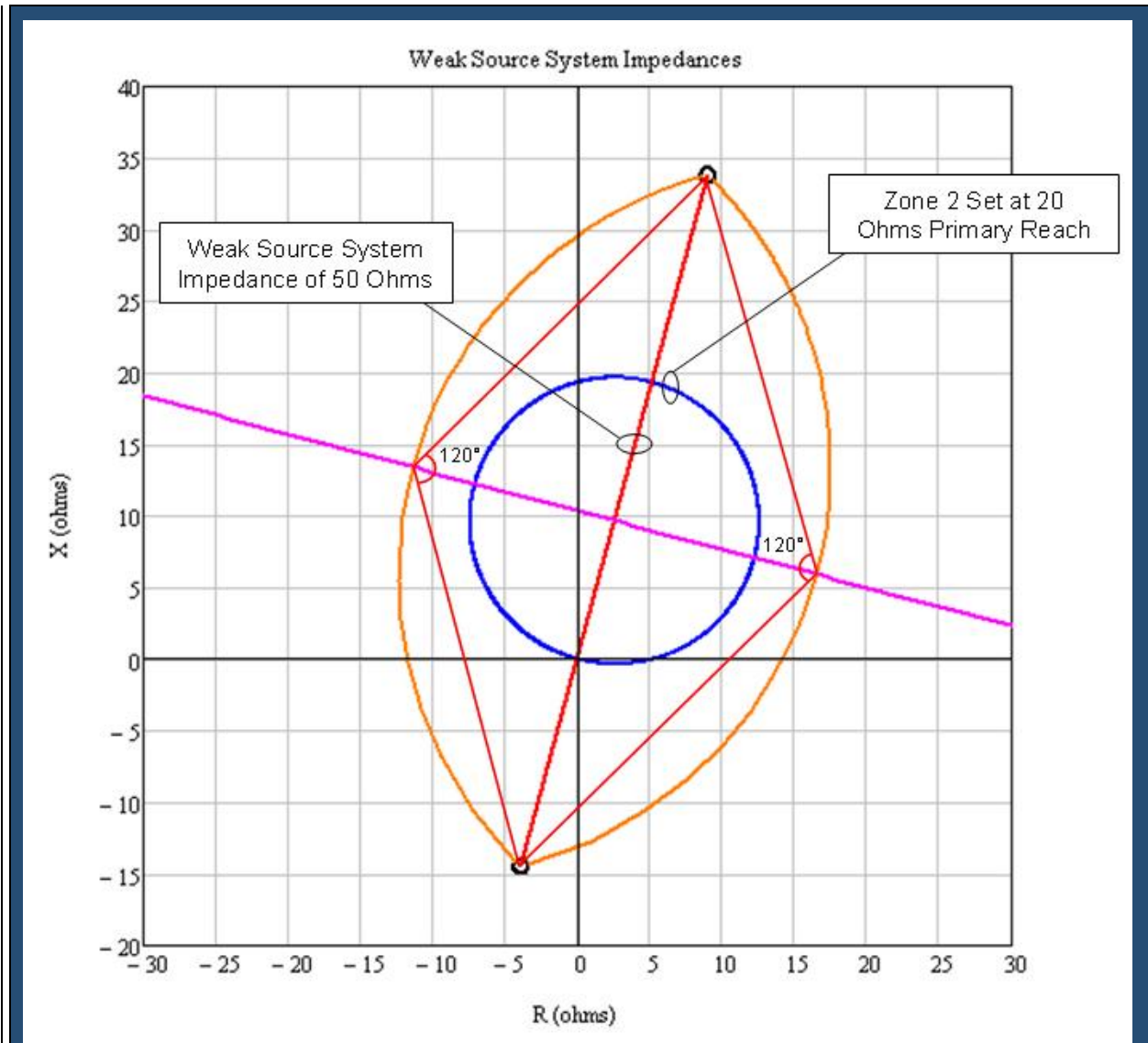
	$E_S = \frac{230,000 \angle 120^\circ V}{\sqrt{3}} \times 0.70$
	$E_S = 92,953.7 \angle 120^\circ V$
Eq. (15)	$E_R = \frac{V_{LL} \angle 0^\circ}{\sqrt{3}}$
	$E_R = \frac{230,000 \angle 0^\circ V}{\sqrt{3}}$
	$E_R = 132,791 \angle 0^\circ V$



**Table 3. Example Calculation (Lens Point 2)**

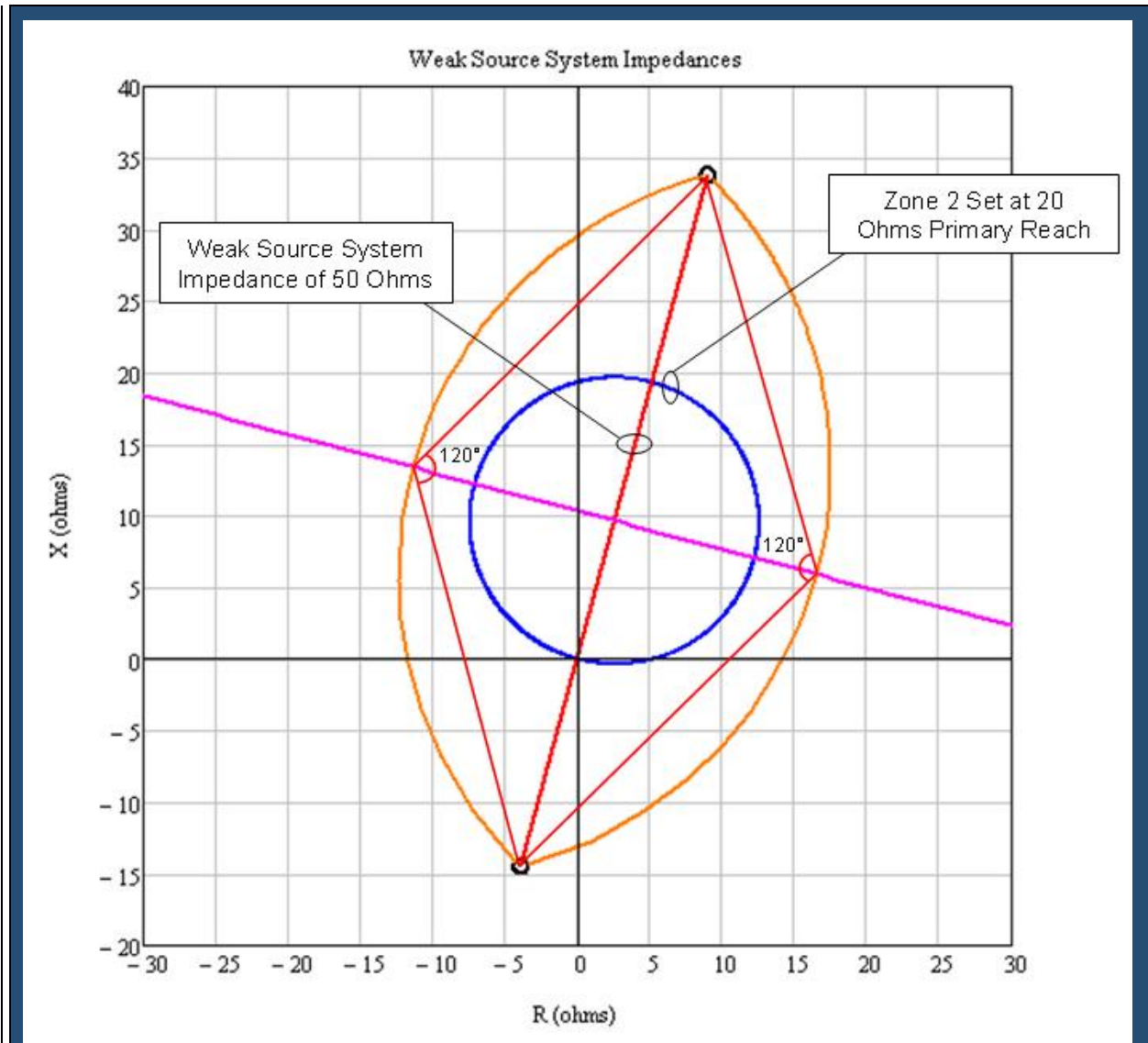
Given positive sequence impedance data (The transfer impedance  $Z_{TR}$  is set to infinity).

<u>Given:</u>	$Z_S = 2 + j10 \Omega$	$Z_L = 4 + j20 \Omega$	$Z_R = 4 + j20 \Omega$
<u>Given:</u>	$Z_{TR} = Z_L \times 10^{10} \Omega$		
<u>Total impedance between generators.</u>			
<u>Eq. (16)</u>	$Z_{total} = \frac{(Z_L \times Z_{TR})}{(Z_L + Z_{TR})}$		
	$Z_{total} = \frac{((4 + j20) \Omega \times (4 + j20)^{10} \Omega)}{((4 + j20) \Omega + (4 + j20)^{10} \Omega)}$		



**Table 3. Example Calculation (Lens Point 2)**

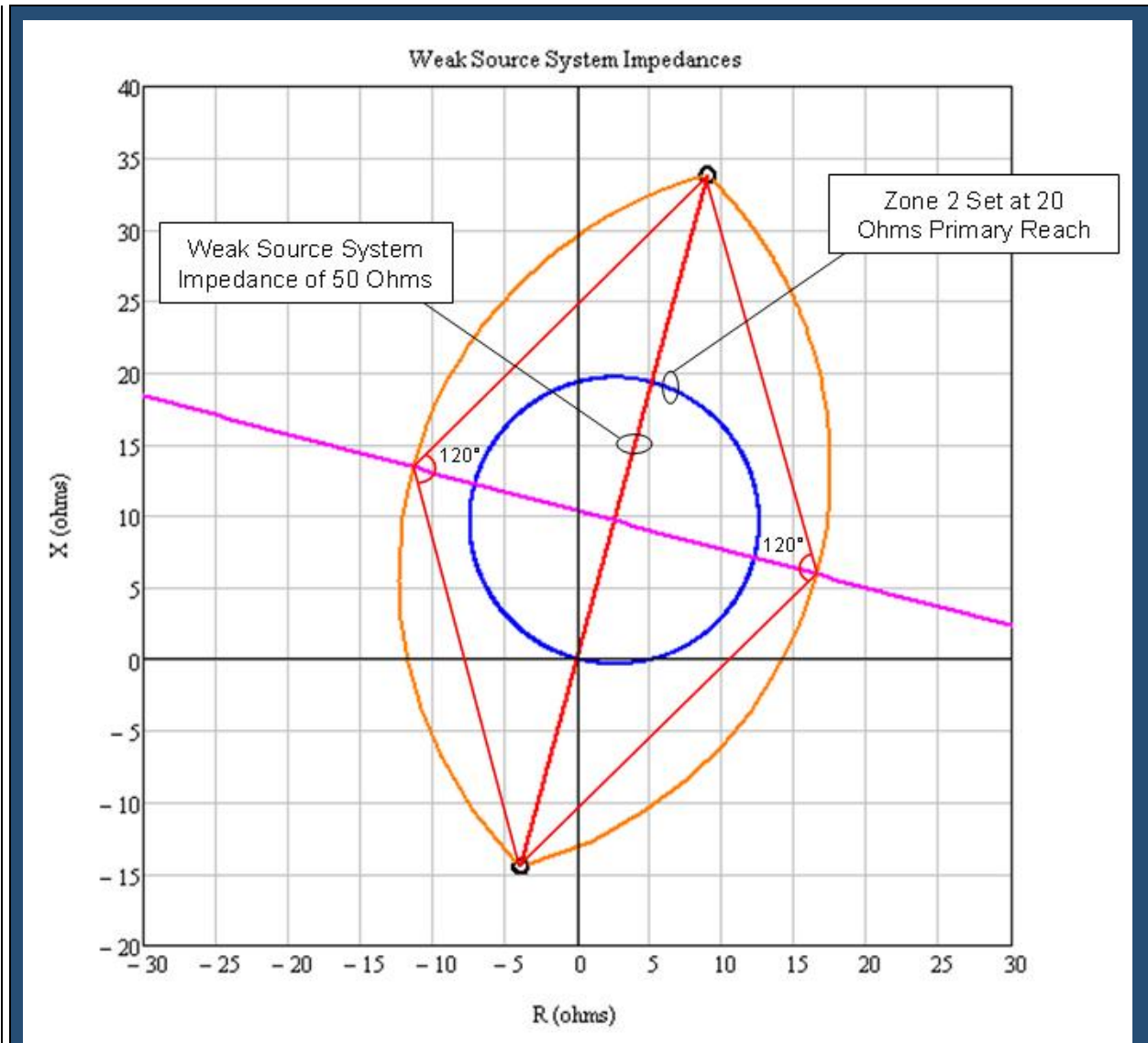
	$Z_{total} = 4 + j20 \Omega$
<u>Total system impedance.</u>	
<u>Eq. (17)</u>	$Z_{sys} = Z_S + Z_{total} + Z_R$
	$Z_{sys} = (2 + j10) \Omega + (4 + j20) \Omega + (4 + j20) \Omega$
	$Z_{sys} = 10 + j50 \Omega$



**Table 3. Example Calculation (Lens Point 2)**

Total system current from sending source.

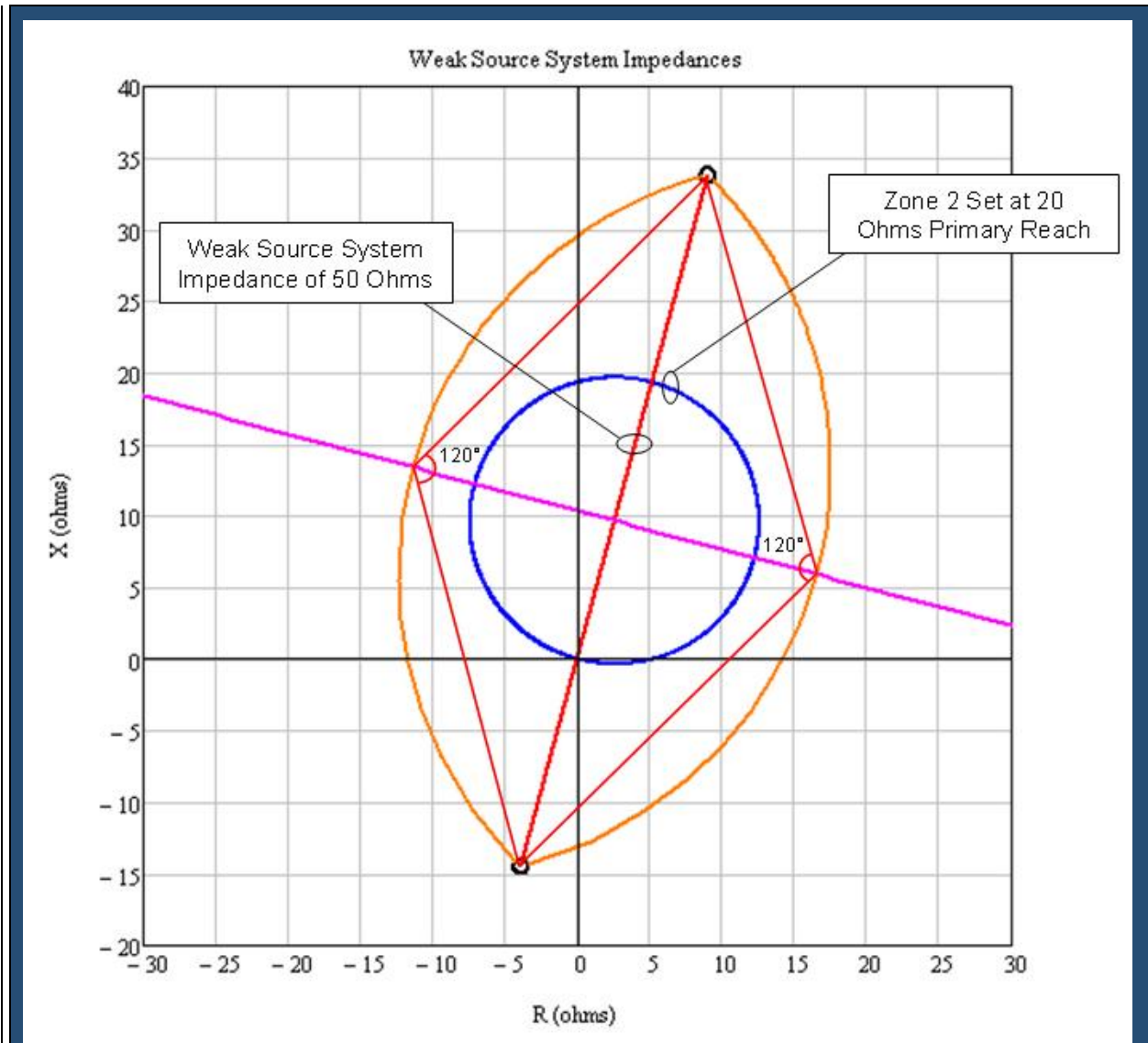
Eq. (18)	$I_{sys} = \frac{E_S - E_R}{Z_{sys}}$
	$I_{sys} = \frac{92,953.7 \angle 120^\circ V - 132,791 \angle 0^\circ V}{(10 + j50) \Omega}$
	$I_{sys} = 3,854 \angle 77^\circ A$



**Table 3. Example Calculation (Lens Point 2)**

The current as measured by the relay on ZL is only the current flowing through that line as determined by using the current divider equation.

Eq. (19)	$I_L = I_{sys} \times \frac{Z_{TR}}{Z_L + Z_{TR}}$
	$I_L = 3,854 \angle 77^\circ A \times \frac{(4 + j20)^{10} \Omega}{(4 + j20) \Omega + (4 + j20)^{10} \Omega}$
	$I_L = 3,854 \angle 77^\circ A$



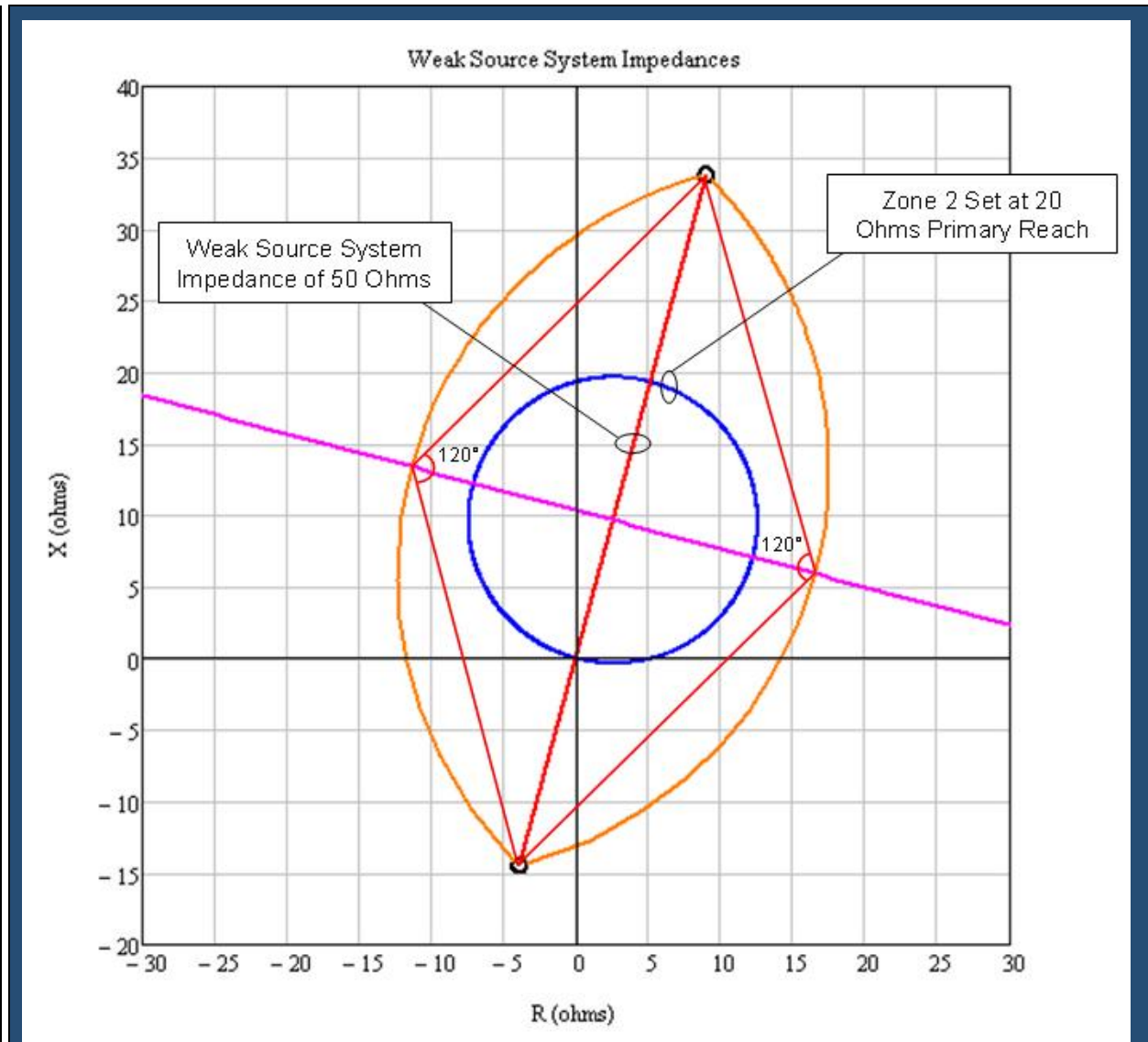
**Table 3. Example Calculation (Lens Point 2)**

The voltage as measured by the relay on  $Z_L$  is the voltage drop from the sending source through the sending source impedance.

Eq. (20)	$V_S = E_S - (Z_S \times I_{sys})$
	$V_S = 92,953 \angle 120^\circ V - [(2 + j10) \Omega \times 3,854 \angle 77^\circ A]$
	$V_S = 65,271 \angle 99^\circ V$

The impedance seen by the relay on  $Z_L$ .

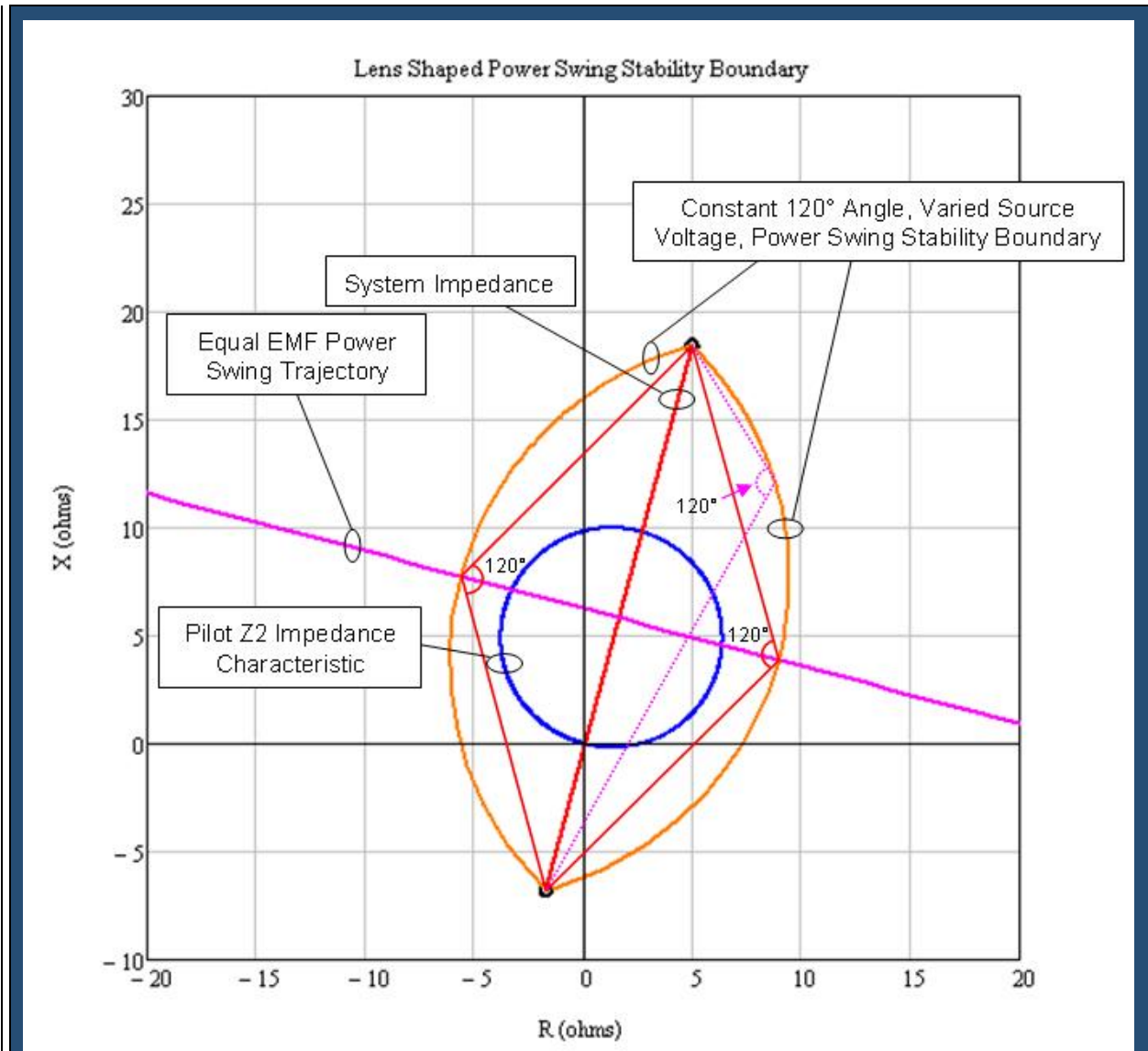
Eq. (21)	$Z_{L-Relay} = \frac{V_S}{I_L}$
----------	---------------------------------



**Table 3. Example Calculation (Lens Point 2)**

	$Z_{L-Relay} = \frac{65,271 \angle 99^\circ V}{3,854 \angle 77^\circ A}$
	$Z_{L-Relay} = 15.676 + j6.41 \Omega$

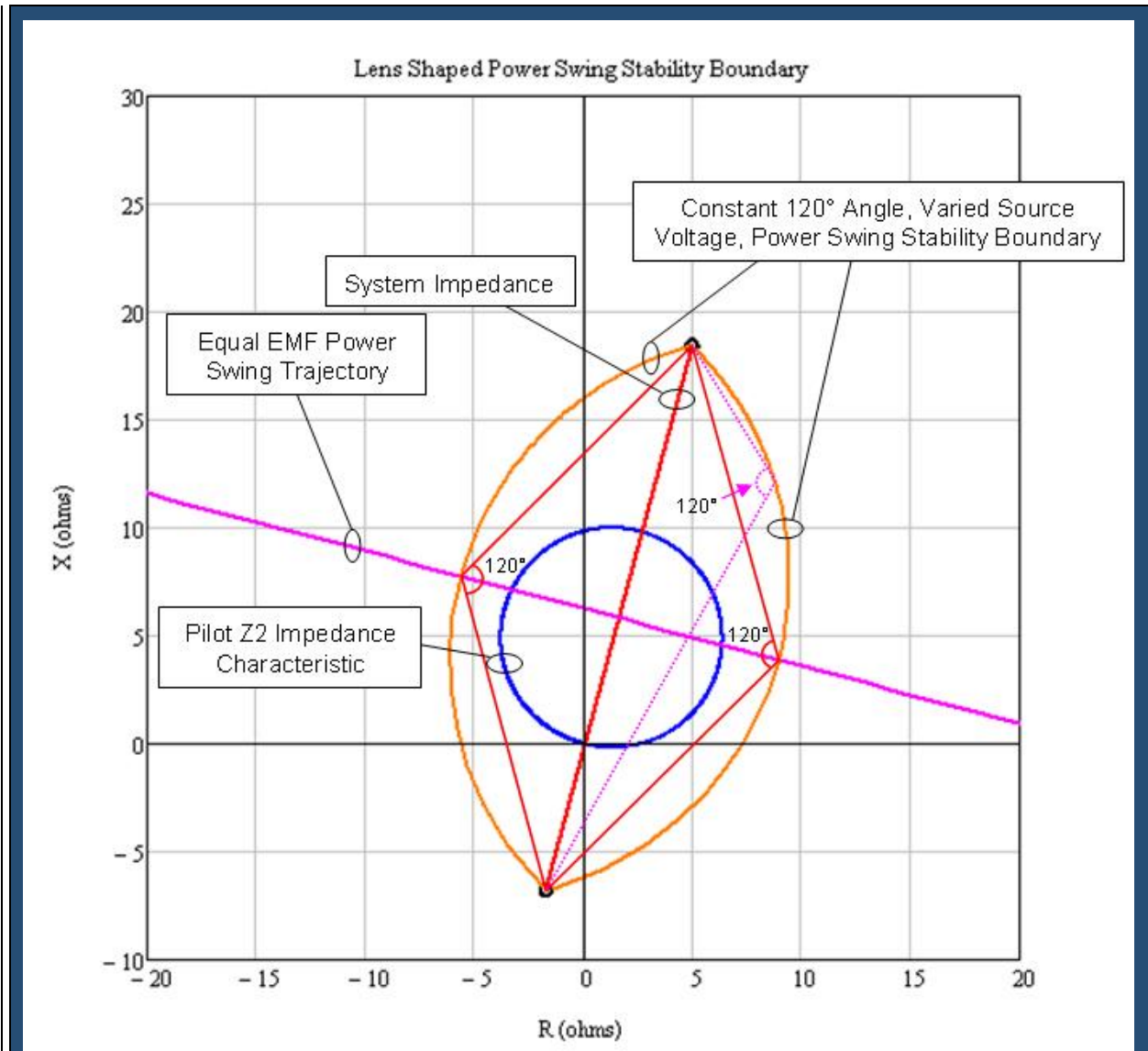




**Table 4. Example Calculation (Lens Point 3)**

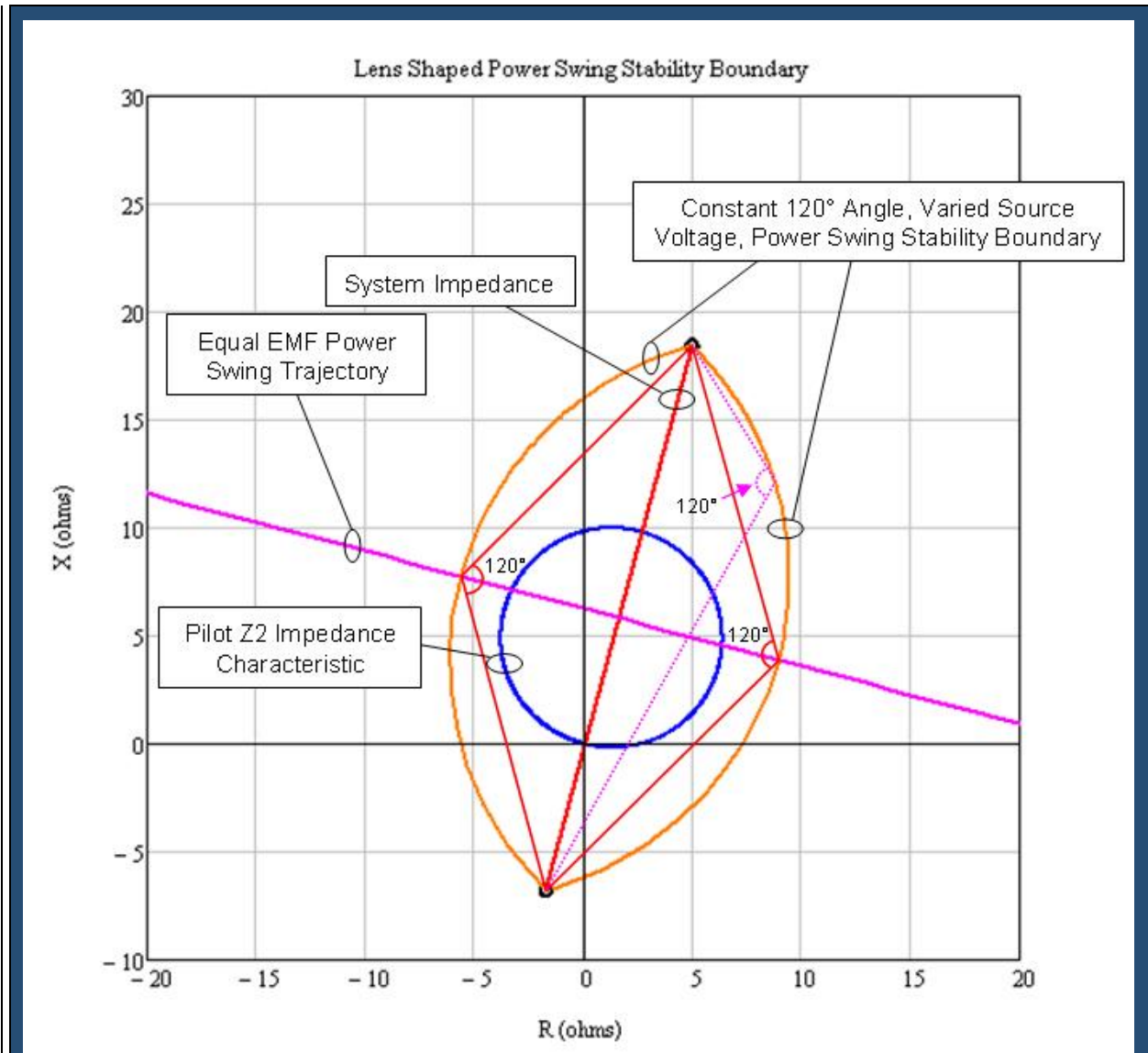
**Figure 6.** The pilot zone 2 element (blue) is completely contained within the power swing stability boundary (orange). This Element passes the Requirement R3 evaluation. This example is for calculating the impedance third point of the lens characteristic. Unequal source voltages are used for the 230 kV (base) line with the receiving voltage ( $E_R$ ) at 70% of the sending voltage ( $E_S$ ) and the sending voltage leading the receiving voltage by 120 degrees. See Figures 4 and 5.

Eq. (22)	$E_S = \frac{V_{LL} \angle 120^\circ}{\sqrt{3}}$
	$E_S = \frac{230,000 \angle 120^\circ V}{\sqrt{3}}$



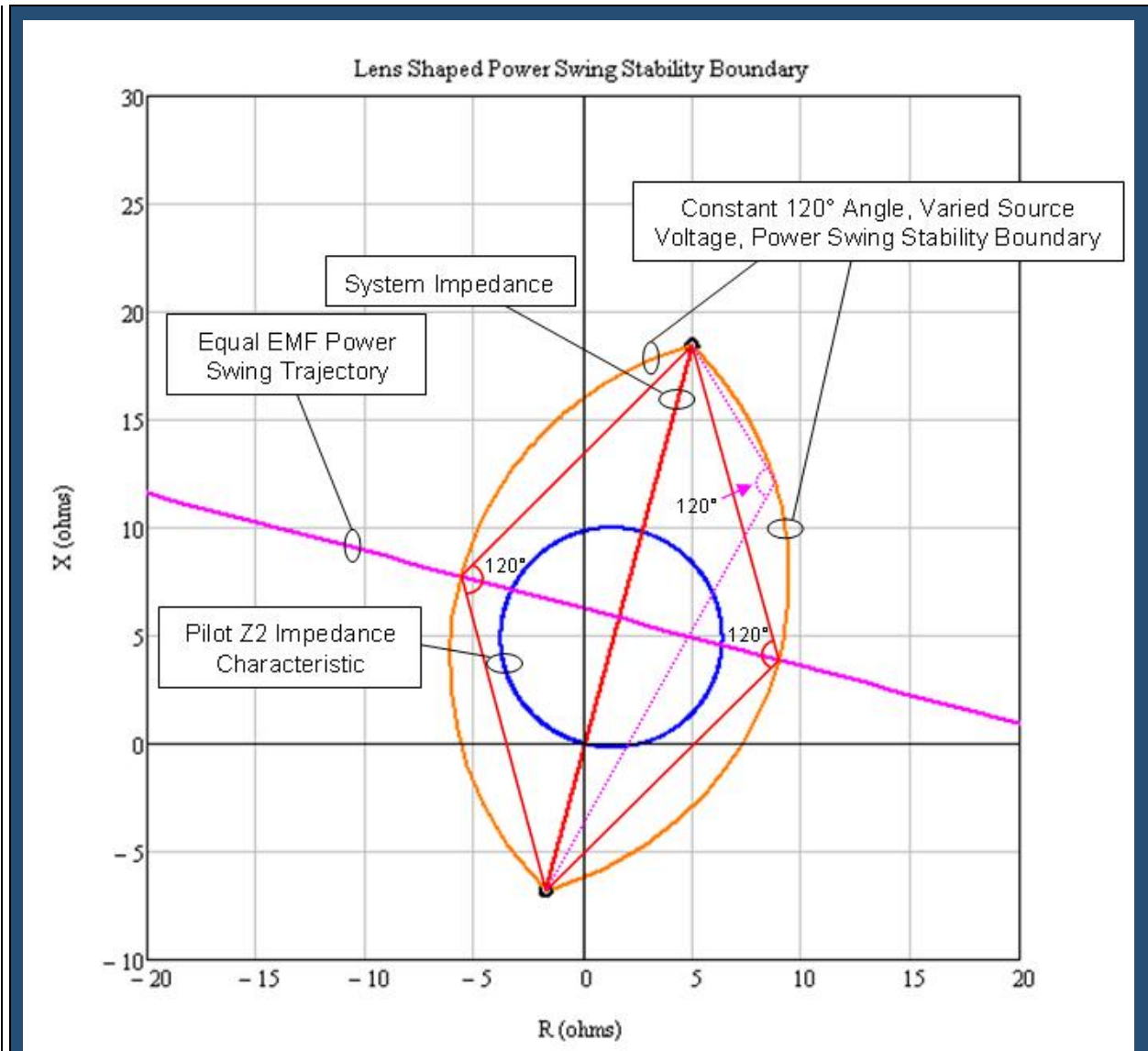
**Table 4. Example Calculation (Lens Point 3)**

	$E_S = 132,791 \angle 120^\circ V$		
<u>Eq. (23)</u>	$E_R = \frac{V_{LL} \angle 0^\circ}{\sqrt{3}} \times 70\%$		
	$E_R = \frac{230,000 \angle 0^\circ V}{\sqrt{3}} \times 0.70$		
	$E_R = 92,953.7 \angle 0^\circ V$		
<u>Given positive sequence impedance data (The transfer impedance <math>Z_{TR}</math> is set to infinity).</u>			
<u>Given:</u>	$Z_S = 2 + j10 \Omega$	$Z_L = 4 + j20 \Omega$	$Z_R = 4 + j20 \Omega$



**Table 4. Example Calculation (Lens Point 3)**

<b>Given:</b>	$Z_{TR} = Z_L \times 10^{10} \Omega$
<b>Total impedance between generators.</b>	
<b>Eq. (24)</b>	$Z_{total} = \frac{(Z_L \times Z_{TR})}{(Z_L + Z_{TR})}$
	$Z_{total} = \frac{((4 + j20) \Omega \times (4 + j20)^{10} \Omega)}{((4 + j20) \Omega + (4 + j20)^{10} \Omega)}$
	$Z_{total} = 4 + j20 \Omega$



**Table 4. Example Calculation (Lens Point 3)**

Total system impedance.

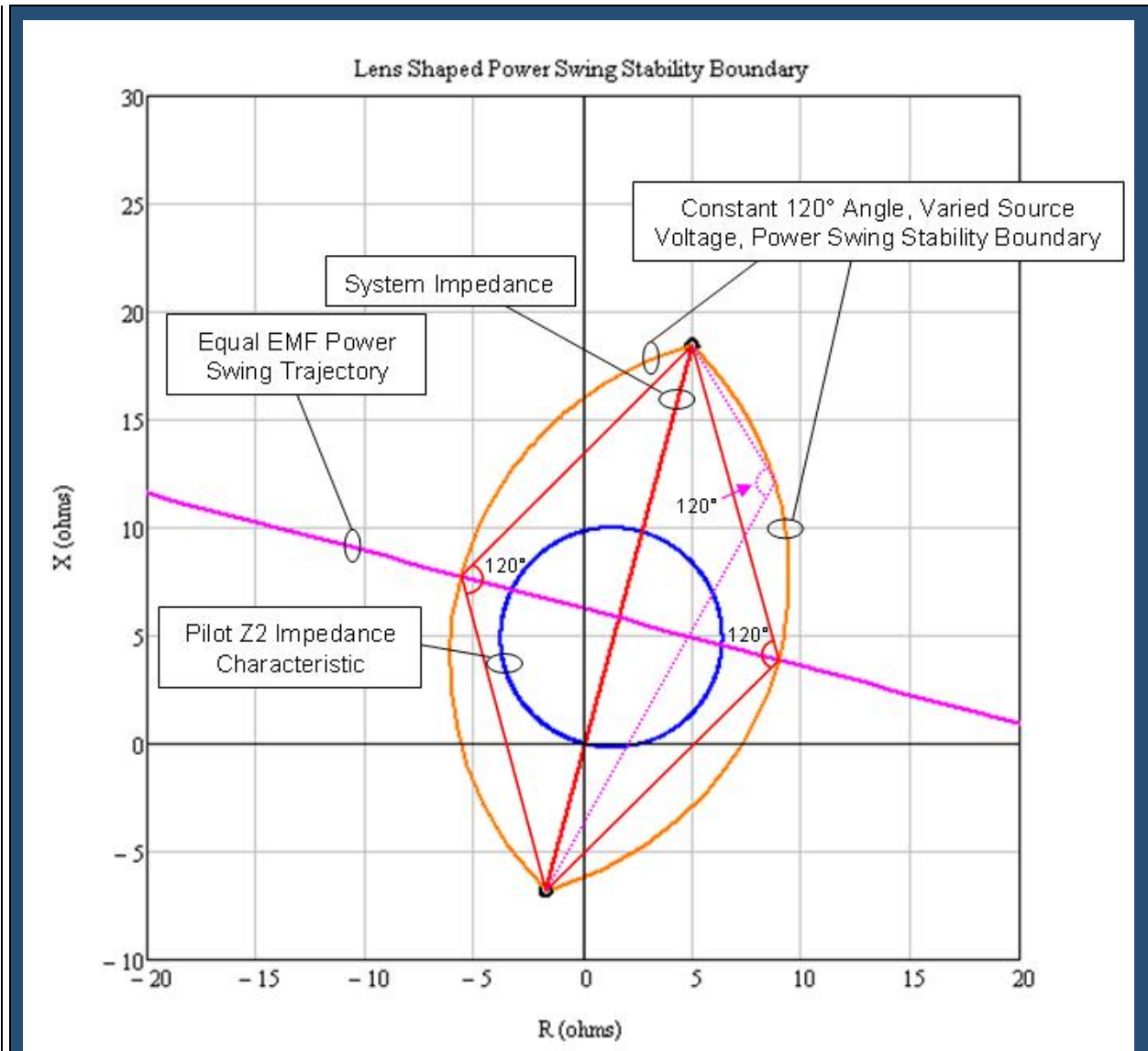
Eq. (25)  $Z_{sys} = Z_S + Z_{total} + Z_R$

$$Z_{sys} = (2 + j10) \Omega + (4 + j20) \Omega + (4 + j20) \Omega$$

$$Z_{sys} = 10 + j50 \Omega$$

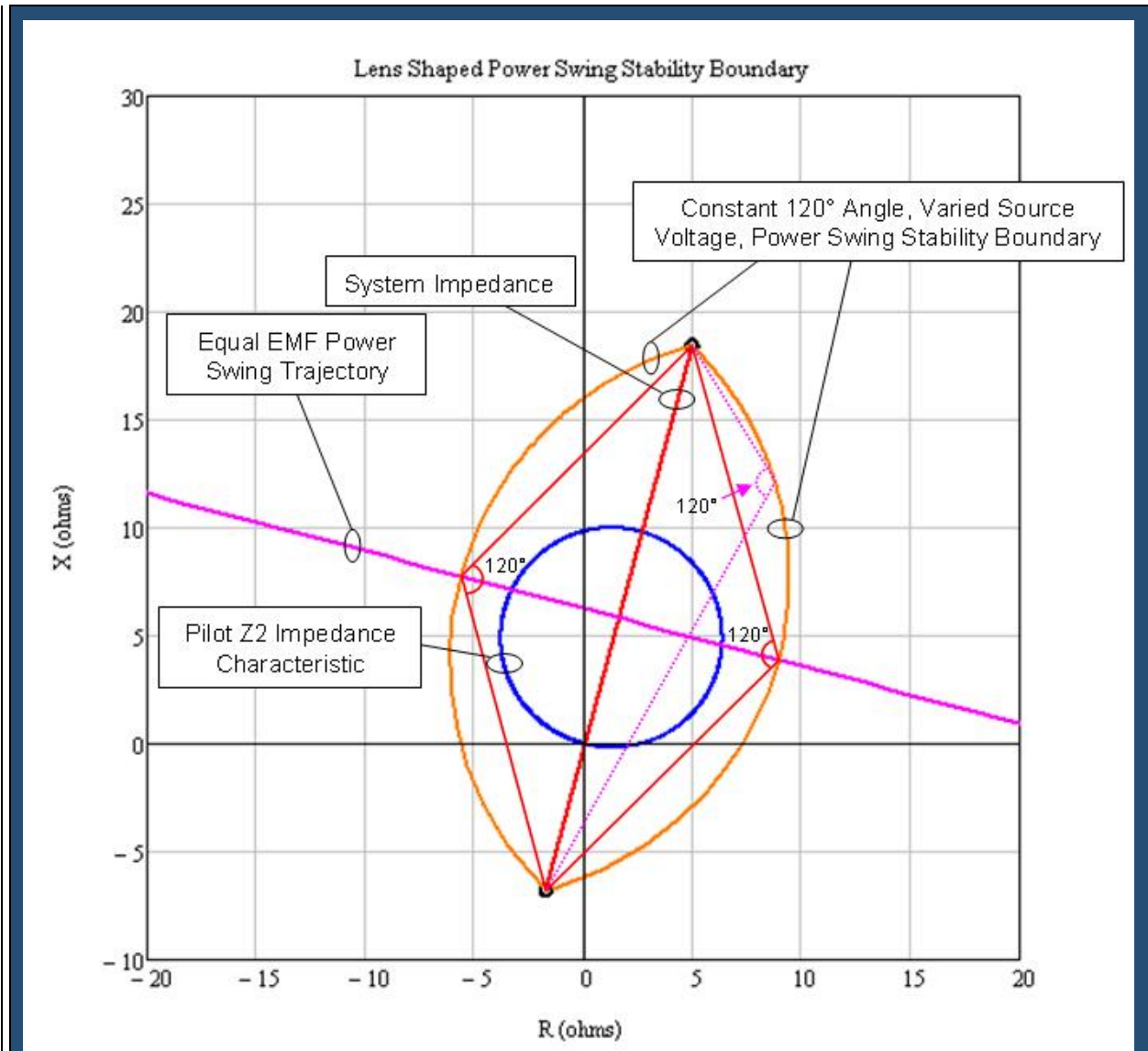
Total system current from sending source.

Eq. (26)  $I_{sys} = \frac{E_S - E_R}{Z_{sys}}$



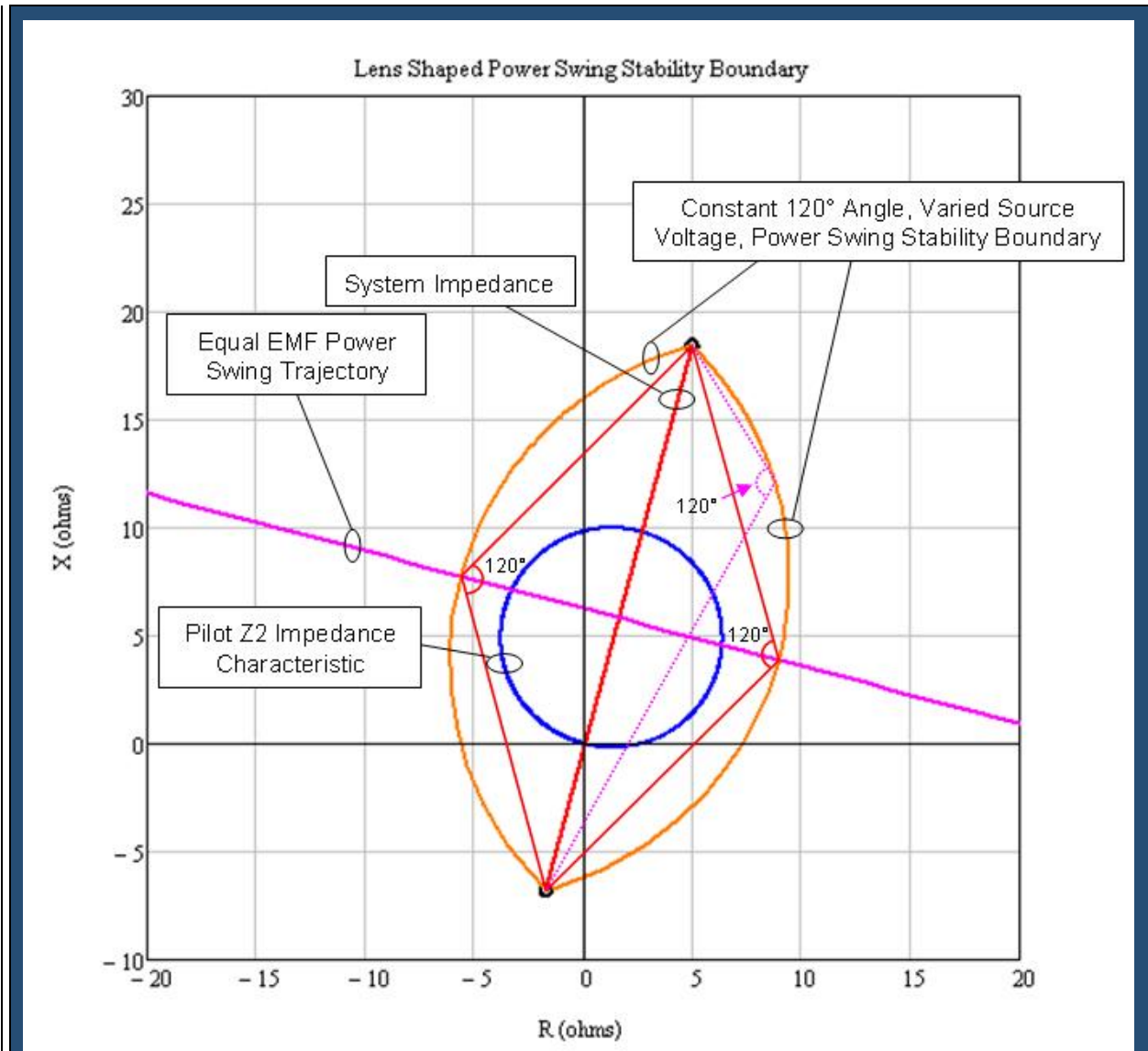
**Table 4. Example Calculation (Lens Point 3)**

	$I_{sys} = \frac{132,791 \angle 120^\circ V - 92,953.7 \angle 0^\circ V}{(10 + j50) \Omega}$
	$I_{sys} = 3,854 \angle 65.5^\circ A$
<p><u>The current as measured by the relay on ZL is only the current flowing through that line as determined by using the current divider equation.</u></p>	
Eq. (27)	$I_L = I_{sys} \times \frac{Z_{TR}}{Z_L + Z_{TR}}$
	$I_L = 3,854 \angle 65.5^\circ A \times \frac{(4 + j20)^{10} \Omega}{(4 + j20) \Omega + (4 + j20)^{10} \Omega}$



**Table 4. Example Calculation (Lens Point 3)**

	$I_L = 3,854 \angle 65.5^\circ A$
<u>The voltage as measured by the relay on <math>Z_L</math> is the voltage drop from the sending source through the sending source impedance.</u>	
Eq. (28)	$V_S = E_S - (Z_S \times I_L)$
	$V_S = 132,791 \angle 120^\circ V - [(2 + j10) \Omega \times 3,854 \angle 65.5^\circ A]$
	$V_S = 98,265 \angle 110.6^\circ V$



**Table 4. Example Calculation (Lens Point 3)**

The impedance seen by the relay on  $Z_L$ .

Eq. (29)	$Z_{L-Relay} = \frac{V_S}{I_L}$
	$Z_{L-Relay} = \frac{98,265 \angle 110.6^\circ V}{3,854 \angle 65.5^\circ A}$
	$Z_{L-Relay} = 18.005 + j18.054 \Omega$

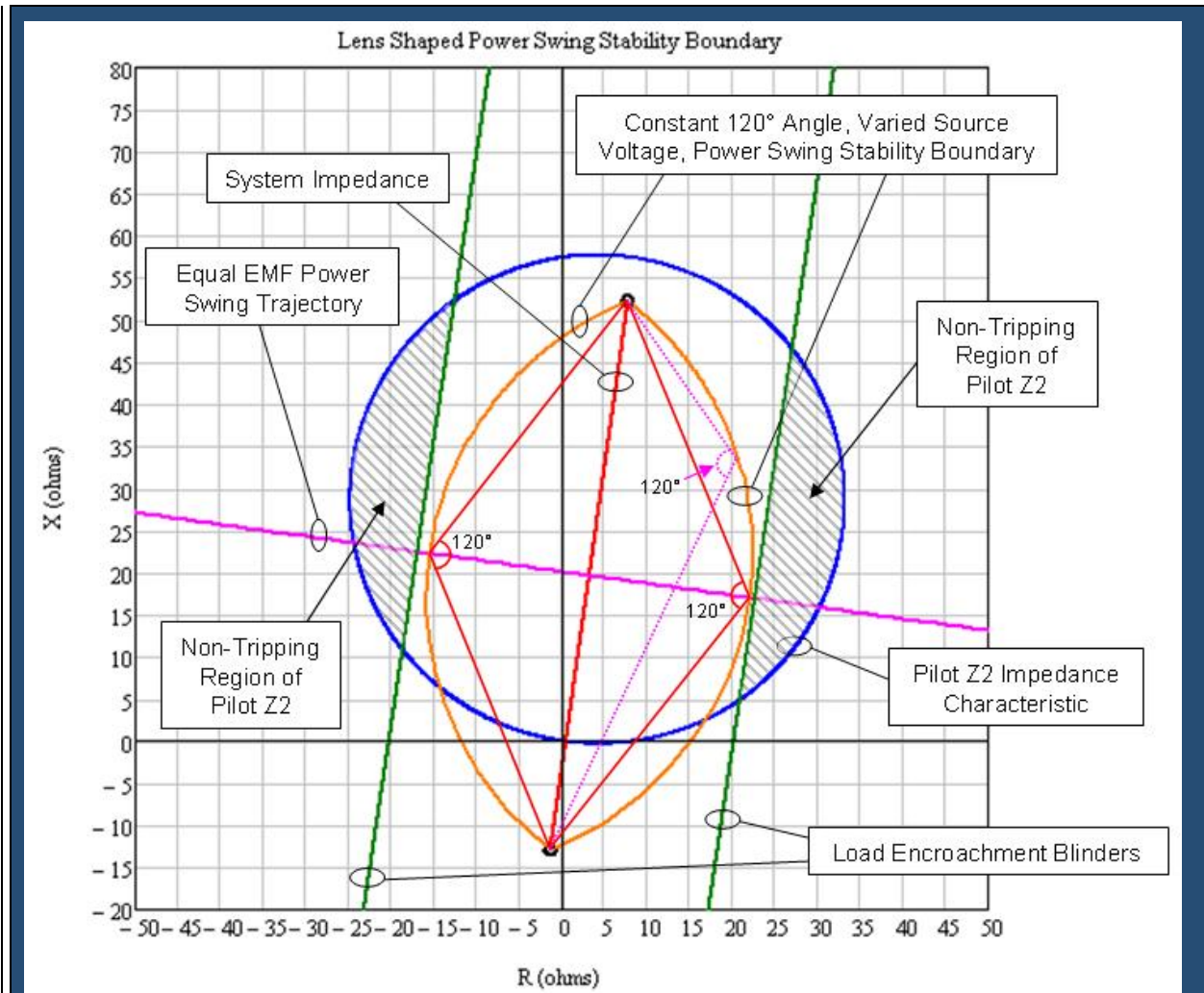


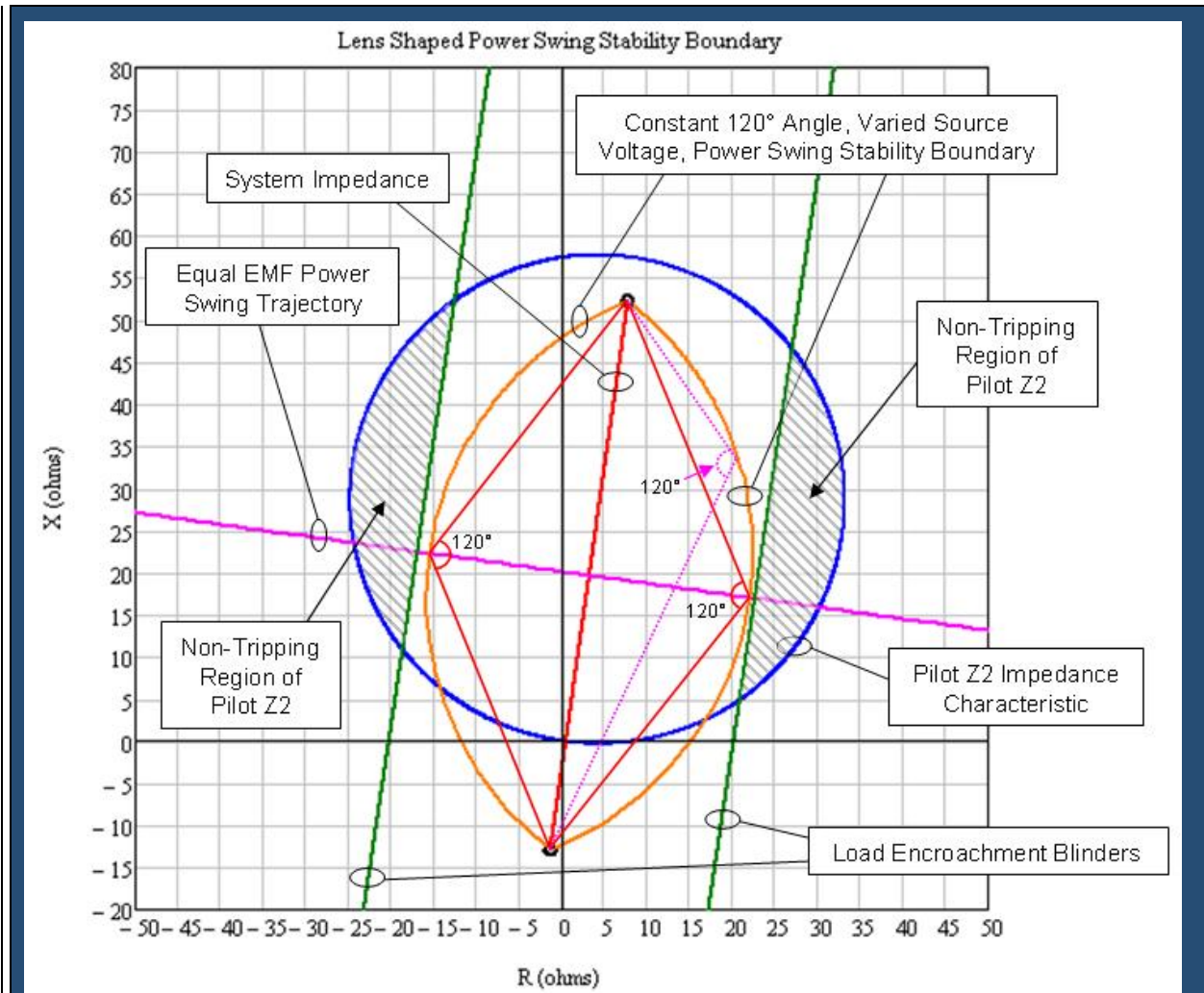
Table 5. Example Calculation (Lens Point 4)

**Figure 7.** The tripping portion (not blocked by load encroachment) of the pilot zone 2 element (blue) is not completely contained within the power swing stability boundary (orange). This Element does not pass the Requirement R3 evaluation. This example is for calculating the impedance fourth point of the lens characteristic. Equal source voltages are used for the 230 kV (base) line with the sending voltage (ES) leading the receiving voltage (ER) by 240 degrees. See Figures 4 and 5.

Eq. (30)	$E_S = \frac{V_{LL} \angle 240^\circ}{\sqrt{3}}$
	$E_S = \frac{230,000 \angle 240^\circ V}{\sqrt{3}}$
	$E_S = 132,791 \angle 240^\circ V$



## Application Guidelines



**Table 5. Example Calculation (Lens Point 4)**

Eq. (31)	$E_R = \frac{V_{LL} \angle 0^\circ}{\sqrt{3}}$		
	$E_R = \frac{230,000 \angle 0^\circ V}{\sqrt{3}}$		
	$E_R = 132,791 \angle 0^\circ V$		
Given positive sequence impedance data (The transfer impedance $Z_{TR}$ is set to infinity).			
Given:	$Z_S = 2 + j10 \Omega$	$Z_L = 4 + j20 \Omega$	$Z_R = 4 + j20 \Omega$
Given:	$Z_{TR} = Z_L \times 10^{10} \Omega$		

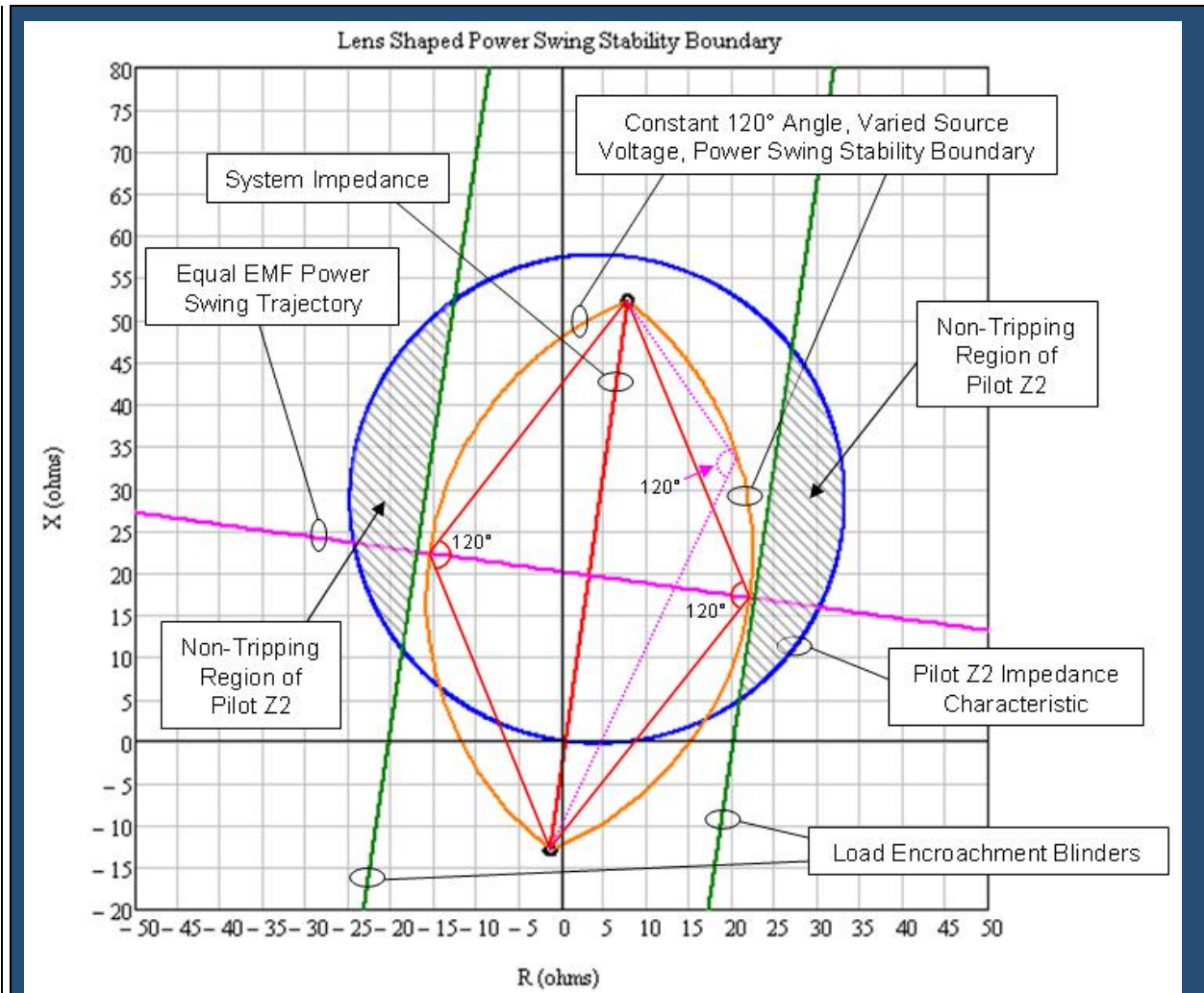


Table 5. Example Calculation (Lens Point 4)

Total impedance between generators.

Eq. (32)

$$Z_{total} = \frac{Z_L \times Z_{TR}}{Z_L + Z_{TR}}$$

$$Z_{total} = \frac{(4 + j20) \Omega \times (4 + j20)^{10} \Omega}{(4 + j20) \Omega + (4 + j20)^{10} \Omega}$$

$$Z_{total} = 4 + j20 \Omega$$

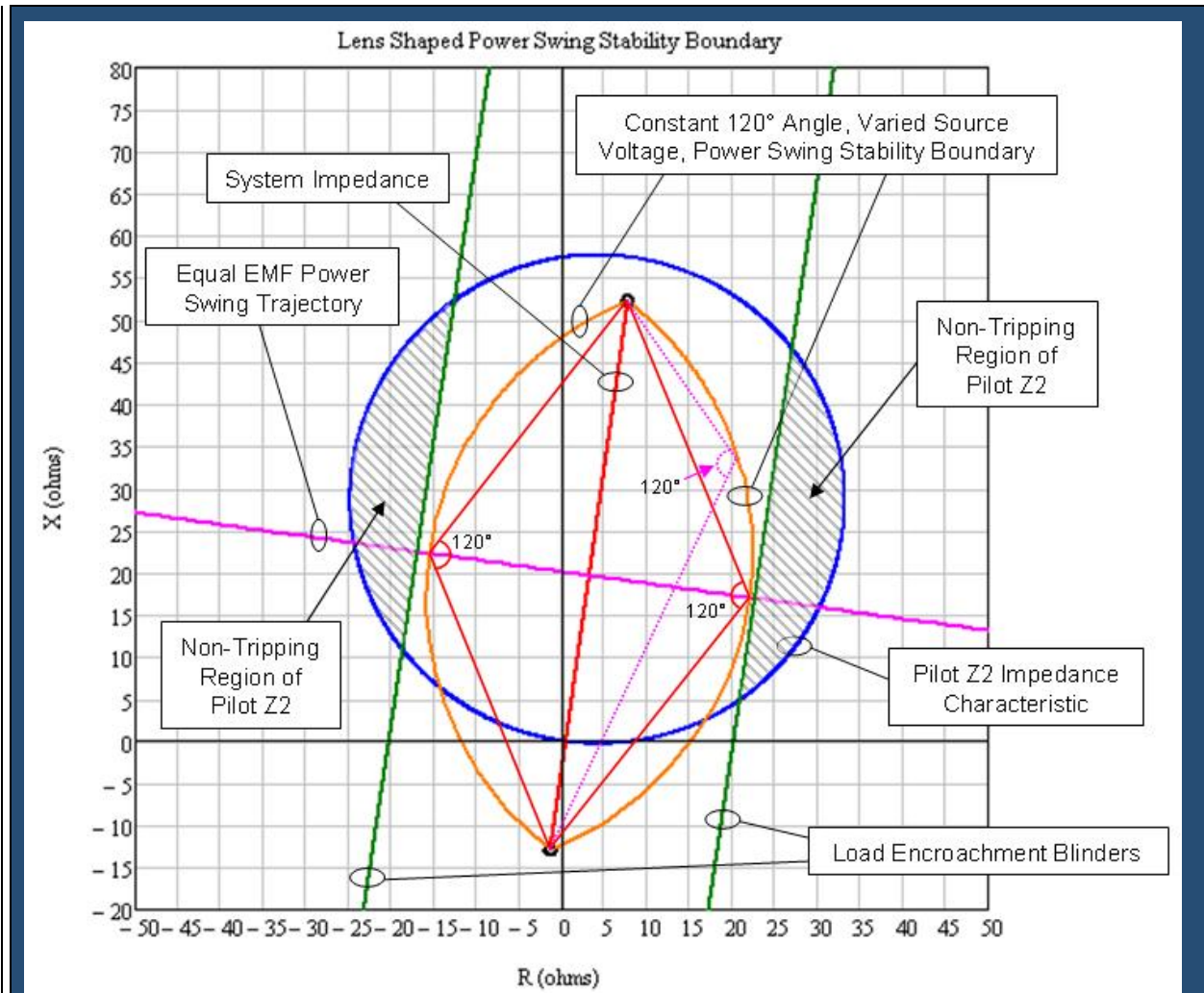
Total system impedance.

Eq. (33)

$$Z_{sys} = Z_S + Z_{total} + Z_R$$

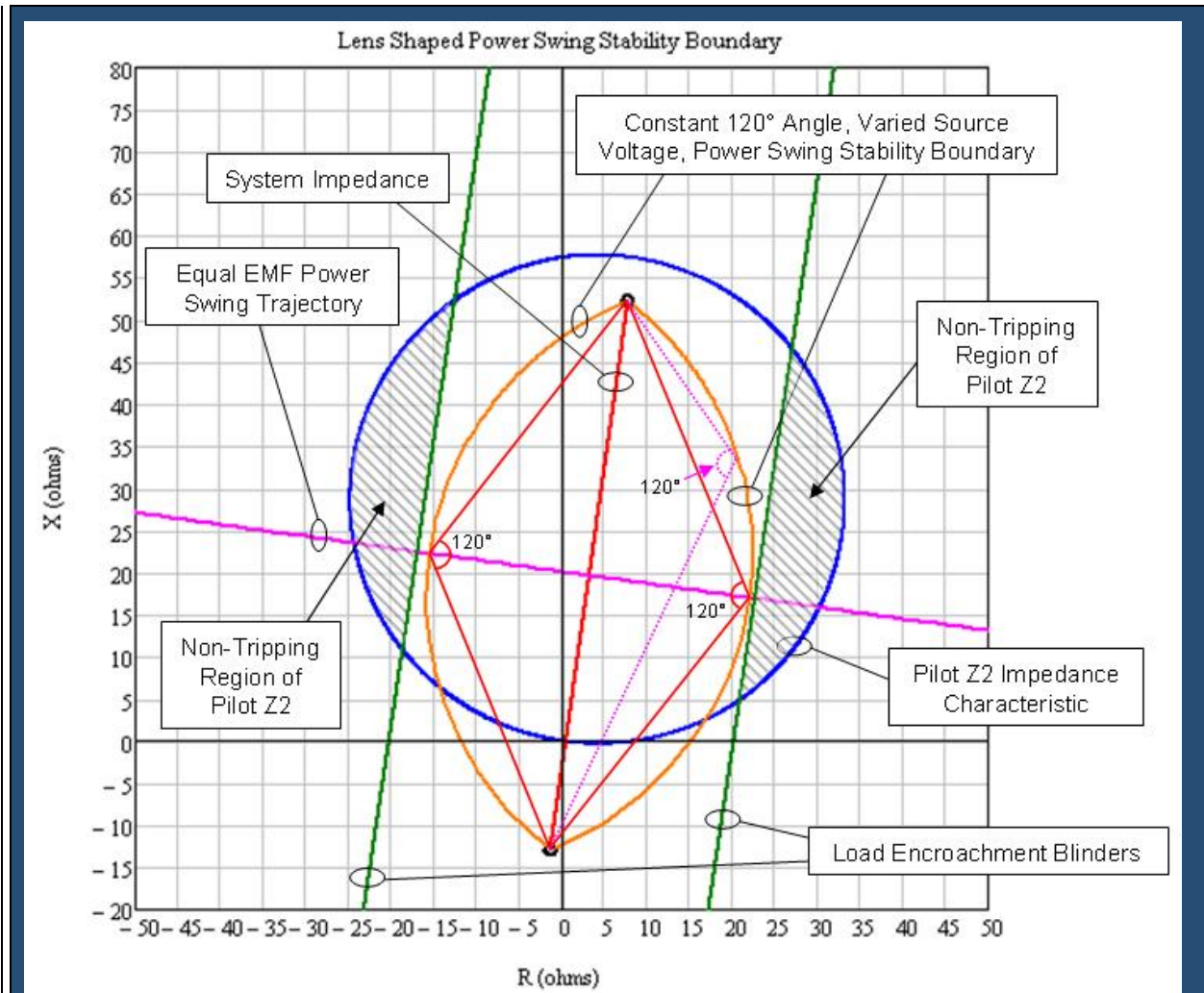
$$Z_{sys} = (2 + j10) \Omega + (4 + j20) \Omega + (4 + j20) \Omega$$

## Application Guidelines



**Table 5. Example Calculation (Lens Point 4)**

	$Z_{sys} = 10 + j50 \Omega$
<u>Total system current from sending source.</u>	
Eq. (34)	$I_{sys} = \frac{E_S - E_R}{Z_{sys}}$
	$I_{sys} = \frac{132,791 \angle 240^\circ V - 132,791 \angle 0^\circ V}{(10 + j50) \Omega}$
	$I_{sys} = 4,510 \angle 131.3^\circ A$



**Table 5. Example Calculation (Lens Point 4)**

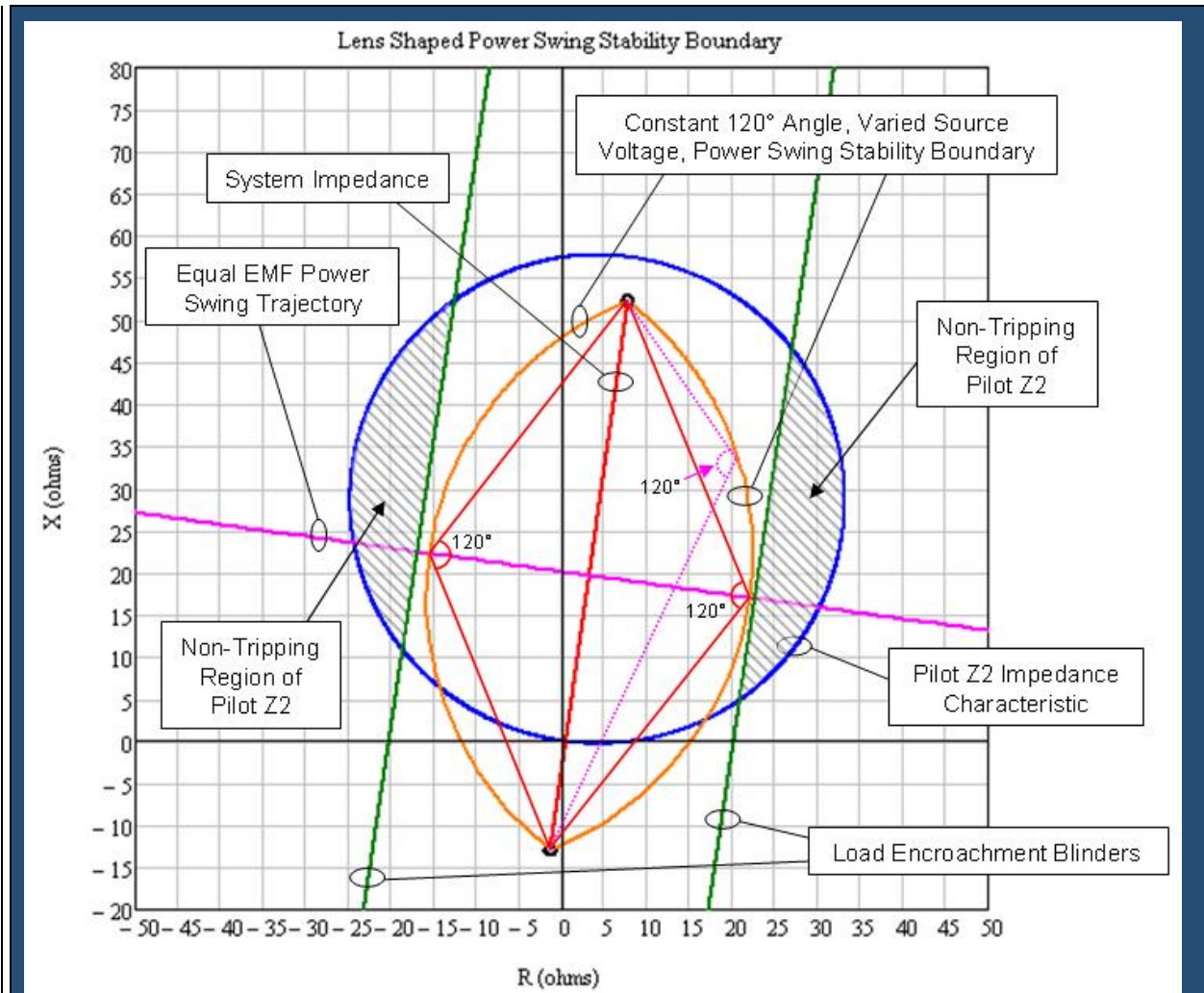
The current as measured by the relay on Z<sub>L</sub> is only the current flowing through that line as determined by using the current divider equation.

Eq. (35)	$I_L = I_{sys} \times \frac{Z_{TR}}{Z_L + Z_{TR}}$
	$I_L = 4,510 \angle 131.1^\circ A \times \frac{(4 + j20)^{10} \Omega}{(4 + j20) \Omega + (4 + j20)^{10} \Omega}$
	$I_L = 4,510 \angle 131.1^\circ A$

The voltage as measured by the relay on Z<sub>L</sub> is the voltage drop from the sending source through the sending source impedance.

Eq. (36)	$V_S = E_S - (Z_S \times I_L)$
----------	--------------------------------

## Application Guidelines



**Table 5. Example Calculation (Lens Point 4)**

	$V_S = 132,791 \angle 240^\circ V - [(2 + j10) \Omega \times 4,510 \angle 131.1^\circ A]$
	$V_S = 95,756 \angle -106.1^\circ V$
<u>The impedance seen by the relay on <math>Z_{L-}</math>.</u>	
Eq. (37)	$Z_{L-Relay} = \frac{V_S}{I_L}$
	$Z_{L-Relay} = \frac{95,756 \angle -106.1^\circ V}{4,510 \angle 131.1^\circ A}$
	$Z_{L-Relay} = -11.434 + j17.887 \Omega$

## Application Guidelines

### *Application to Generator Owners*

Generators have a variety of load responsive protection relays that protect the generator from abnormal operation and are subject to incorrect operation caused by stable power swings. They include protective relays that operate on current or an impedance function. Specific relays are time overcurrent, voltage controlled/restrained overcurrent, loss of field, and distance relays.

### *Impedance Type Relays*

The

**Table 6. Example Calculation (Lens Point 5)**

This example is for calculating the impedance fifth point of the lens characteristic. Unequal source voltages are used for the 230 kV (base) line with the sending voltage ( $E_S$ ) at 70% of the receiving voltage ( $E_R$ ) and leading the receiving voltage by 240 degrees. See Figures 4 and 5.

Eq. (38)	$E_S = \frac{V_{LL} \angle 240^\circ}{\sqrt{3}} \times 70\%$		
	$E_S = \frac{230,000 \angle 240^\circ V}{\sqrt{3}} \times 0.70$		
	$E_S = 92,953.7 \angle 240^\circ V$		
Eq. (39)	$E_R = \frac{V_{LL} \angle 0^\circ}{\sqrt{3}}$		
	$E_R = \frac{230,000 \angle 0^\circ V}{\sqrt{3}}$		
	$E_R = 132,791 \angle 0^\circ V$		
Given positive sequence impedance data (The transfer impedance $Z_{TR}$ is set to infinity).			
Given:	$Z_S = 2 + j10 \Omega$	$Z_L = 4 + j20 \Omega$	$Z_R = 4 + j20 \Omega$
Given:	$Z_{TR} = Z_L \times 10^{10} \Omega$		
Total impedance between generators.			
Eq. (40)	$Z_{total} = \frac{(Z_L \times Z_{TR})}{(Z_L + Z_{TR})}$		
	$Z_{total} = \frac{((4 + j20) \Omega \times (4 + j20)^{10} \Omega)}{((4 + j20) \Omega + (4 + j20)^{10} \Omega)}$		

## Application Guidelines

<b>Table 6. Example Calculation (Lens Point 5)</b>	
	$Z_{total} = 4 + j20 \Omega$
<u>Total system impedance.</u>	
<u>Eq. (41)</u>	$Z_{sys} = Z_S + Z_{total} + Z_R$
	$Z_{sys} = (2 + j10 \Omega) + (4 + j20 \Omega) + (4 + j20 \Omega)$
	$Z_{sys} = 10 + j50 \Omega$
<u>Total system current from sending source.</u>	
<u>Eq. (42)</u>	$I_{sys} = \frac{E_S - E_R}{Z_{sys}}$
	$I_{sys} = \frac{92,953.7 \angle 240^\circ V - 132,791 \angle 0^\circ V}{10 + j50 \Omega}$
	$I_{sys} = 3,854 \angle 125.5^\circ A$
<u>The current as measured by the relay on <math>Z_L</math> is only the current flowing through that line as determined by using the current divider equation.</u>	
<u>Eq. (43)</u>	$I_L = I_{sys} \times \frac{Z_{TR}}{Z_L + Z_{TR}}$
	$I_L = 3,854 \angle 125.5^\circ A \times \frac{(4 + j20)^{10} \Omega}{(4 + j20) \Omega + (4 + j20)^{10} \Omega}$
	$I_L = 3,854 \angle 125.5^\circ A$
<u>The voltage as measured by the relay on <math>Z_L</math> is the voltage drop from the sending source through the sending source impedance.</u>	
<u>Eq. (44)</u>	$V_S = E_S - (Z_S \times I_L)$
	$V_S = 92,953.7 \angle 240^\circ V - [(2 + j10) \Omega \times 3,854 \angle 125.5^\circ A]$
	$V_S = 65,270.5 \angle -99.4^\circ V$
<u>The impedance seen by the relay on <math>Z_L</math>.</u>	
<u>Eq. (45)</u>	$Z_{L-Relay} = \frac{V_S}{I_L}$

## Application Guidelines

**Table 6. Example Calculation (Lens Point 5)**

	$Z_{L-Relay} = \frac{65,270.5 \angle -99.4^\circ V}{3,854 \angle 125.5^\circ A}$
	$Z_{L-Relay} = -12.005 + j11.946 \Omega$

**Table 7. Example Calculation (Lens Point 6)**

This example is for calculating the impedance sixth point of the lens characteristic. Unequal source voltages are used for the 230 kV (base) line with the receiving voltage ( $E_R$ ) at 70% of the sending voltage ( $E_S$ ) and the sending voltage leading the receiving voltage by 240 degrees. See Figures 4 and 5.

Eq. (46)	$E_S = \frac{V_{LL} \angle 240^\circ}{\sqrt{3}}$
	$E_S = \frac{230,000 \angle 240^\circ V}{\sqrt{3}}$
	$E_S = 132,791 \angle 240^\circ V$
Eq. (47)	$E_R = \frac{V_{LL} \angle 0^\circ}{\sqrt{3}} \times 70\%$
	$E_R = \frac{230,000 \angle 0^\circ V}{\sqrt{3}} \times 0.70$
	$E_R = 92,953.7 \angle 0^\circ V$

Given positive sequence impedance data (The transfer impedance  $Z_{TR}$  is set to infinity).

Given:	$Z_S = 2 + j10 \Omega$	$Z_L = 4 + j20 \Omega$	$Z_R = 4 + j20 \Omega$
Given:	$Z_{TR} = Z_L \times 10^{10} \Omega$		

Total impedance between generators.

Eq. (48)	$Z_{total} = \frac{(Z_L \times Z_{TR})}{(Z_L + Z_{TR})}$
----------	----------------------------------------------------------



## Application Guidelines

<u>Table 7. Example Calculation (Lens Point 6)</u>	
	$Z_{total} = \frac{(4 + j20) \Omega \times (4 + j20)^{10} \Omega}{(4 + j20) \Omega + (4 + j20)^{10} \Omega}$
	$Z_{total} = 4 + j20 \Omega$
<u>Total system impedance.</u>	
<u>Eq. (49)</u>	$Z_{sys} = Z_S + Z_{total} + Z_R$
	$Z_{sys} = (2 + j10) \Omega + (4 + j20) \Omega + (4 + j20) \Omega$
	$Z_{sys} = 10 + j50 \Omega$
<u>Total system current from sending source.</u>	
<u>Eq. (50)</u>	$I_{sys} = \frac{E_S - E_R}{Z_{sys}}$
	$I_{sys} = \frac{132,791 \angle 240^\circ V - 92,953.7 \angle 0^\circ V}{10 + j50 \Omega}$
	$I_{sys} = 3,854 \angle 137.1^\circ A$
<u>The current as measured by the relay on <math>Z_L</math> is only the current flowing through that line as determined by using the current divider equation.</u>	
<u>Eq. (51)</u>	$I_L = I_{sys} \times \frac{Z_{TR}}{Z_L + Z_{TR}}$
	$I_L = 3,854 \angle 137.1^\circ A \times \frac{(4 + j20)^{10} \Omega}{(4 + j20) \Omega + (4 + j20)^{10} \Omega}$
	$I_L = 3,854 \angle 137.1^\circ A$
<u>The voltage as measured by the relay on <math>Z_L</math> is the voltage drop from the sending source through the sending source impedance.</u>	
<u>Eq. (52)</u>	$V_S = E_S - (Z_S \times I_L)$
	$V_S = 132,791 \angle 240^\circ V - [(2 + j10) \Omega \times 3,854 \angle 137.1^\circ A]$
	$V_S = 98,265 \angle -110.6^\circ V$

**Table 7. Example Calculation (Lens Point 6)**

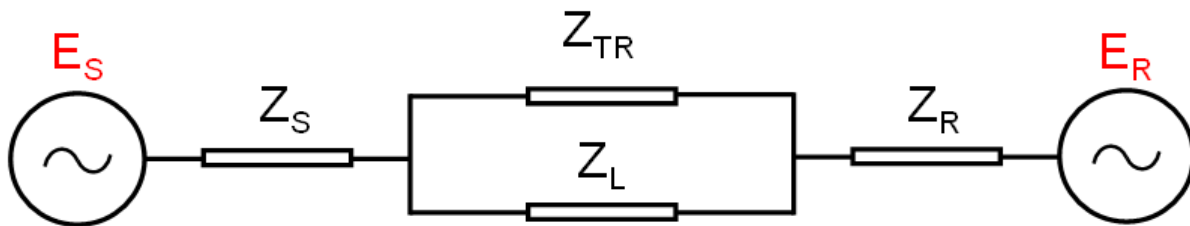
The impedance seen by the relay on  $Z_L$ .

Eq. (53)

$$Z_{L-Relay} = \frac{V_S}{I_L}$$

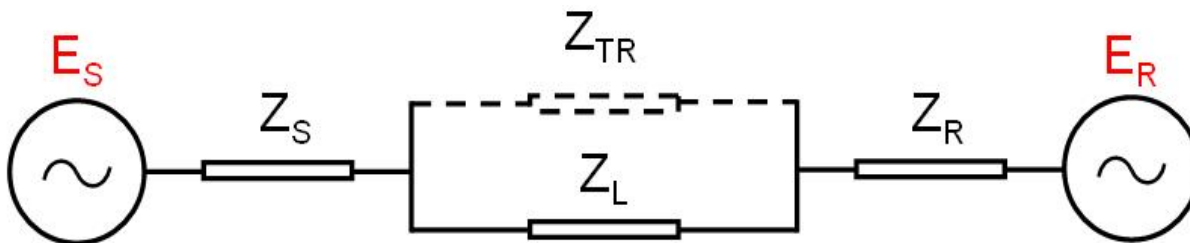
$$Z_{L-Relay} = \frac{98,265 \angle -110.6^\circ V}{3,854 \angle 137.1^\circ A}$$

$$Z_{L-Relay} = -9.676 + j23.59 \Omega$$



$$Z_{Total} = Z_S + \frac{Z_L \cdot Z_{TR}}{Z_L + Z_{TR}} + Z_R$$

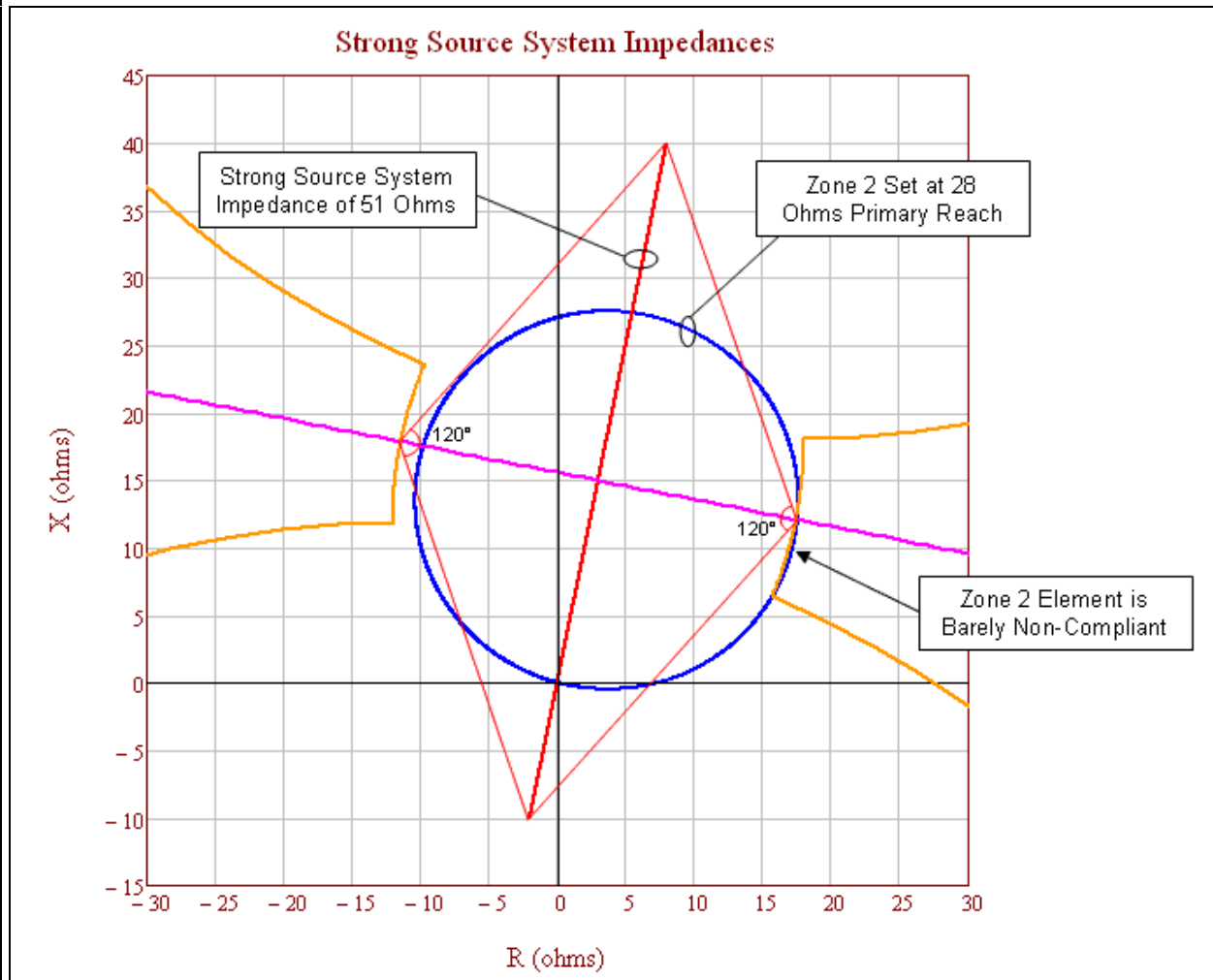
**Figure 6.** Reduced two bus system with sending-end source impedance  $Z_S$ , receiving-end source impedance  $Z_R$ , line impedance  $Z_L$ , and transfer impedance  $Z_{TR}$ .



$$Z_{sys} = Z_S + Z_L + Z_R$$

**Figure 7.** Reduced two bus system with sending-end source impedance  $Z_S$ , receiving-end source

impedance  $Z_R$ , line impedance  $Z_L$ , and transfer impedance  $Z_{TR}$  removed.

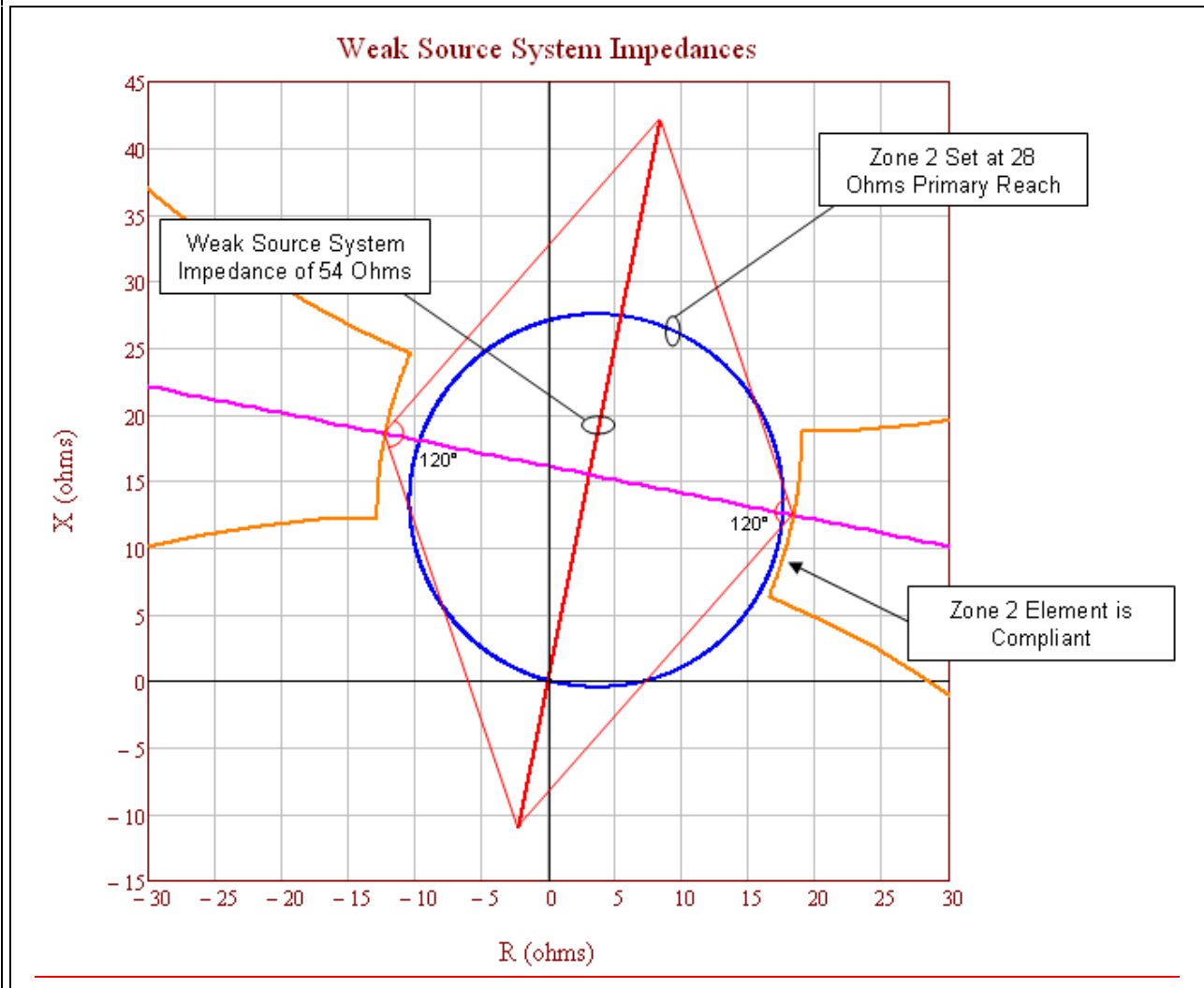


**Figure 8.** A strong-source system with a line impedance of  $Z_L = 20.4$  ohms (i.e., the thicker red line). This relay element (i.e., the blue circle) does not meet the PRC-026-1 – Attachment B, Criteria A because it is not completely contained within the power swing stability boundary (i.e., the orange lens characteristic).

The figure above represents a heavily loaded system using a maximum generation profile. The zone 2 mho circle (set at 137% of  $Z_L$ ) extends into the power swing stability boundary (i.e., the orange partial lens characteristic). Using the strongest source system is more conservative because it shrinks the power swing stability boundary, bringing it closer to the mho circle. This figure also graphically represents the effect of a system strengthening over time and this is the reason for re-evaluation if the relay has not been evaluated in the last three calendar years. Figure 9 below depicts a relay that meets the, PRC-026-1 – Attachment B, Criteria A. Figure 8 depicts

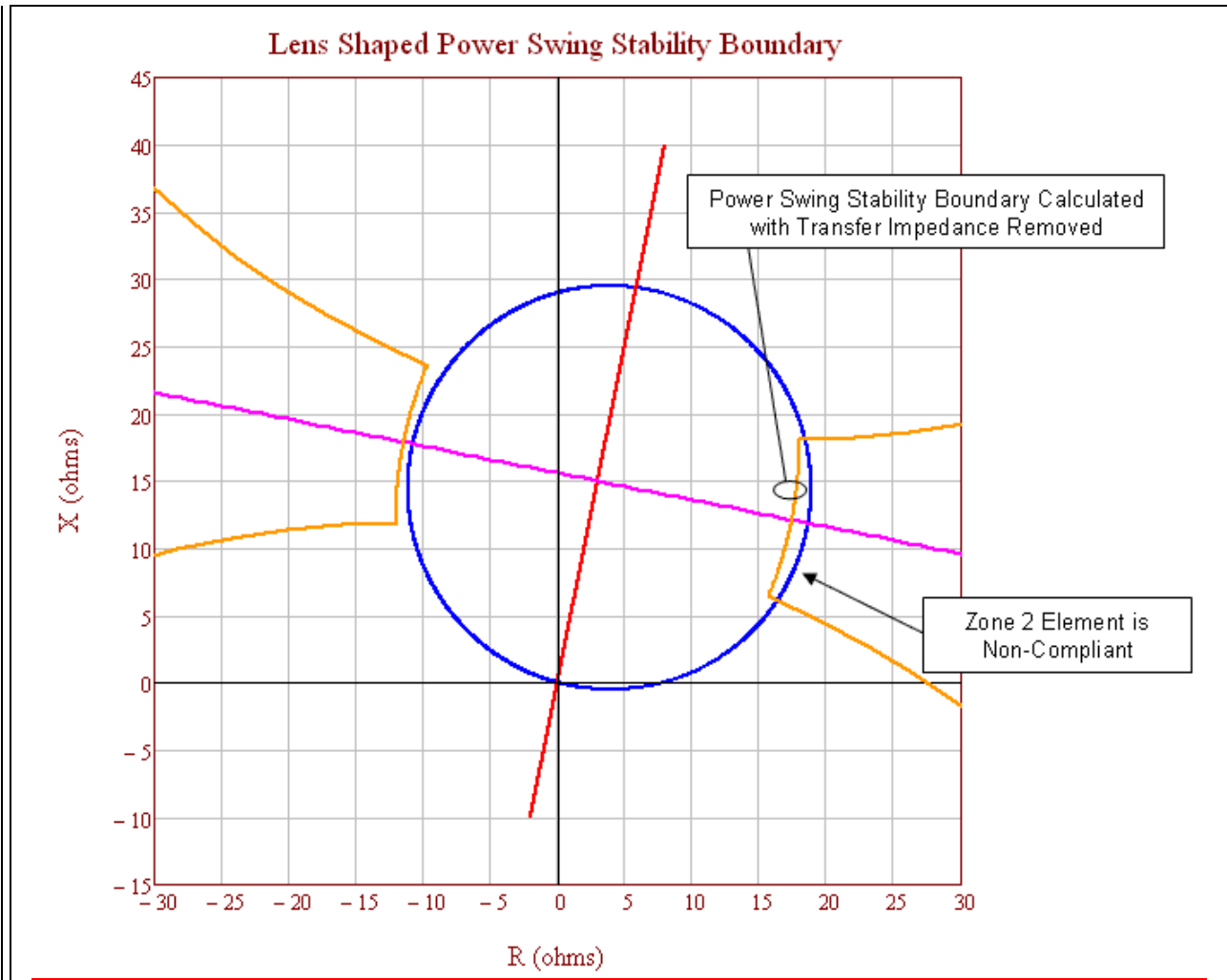
## Application Guidelines

the same relay with the same setting three years later, where each source has strengthened by about 10% and now the same zone 2 element does not meet Criteria A.



**Figure 9.** A weak-source system with a line impedance of  $Z_L = 20.4$  ohms (i.e., the thicker red line). This zone 2 element (i.e., the blue circle) meets the PRC-026-1 – Attachment B, Criteria A because it is completely contained within the power swing stability boundary (i.e., the orange lens characteristic).

The figure above represents a lightly loaded system, using a minimum generation profile. The zone 2 mho circle (set at 137% of  $Z_L$ ) does not extend into the power swing stability boundary (i.e., the orange lens characteristic). Using a weaker source system expands the power swing stability boundary away from the mho circle.



**Figure 10.** This is an example of a power swing stability boundary (i.e., the orange lens characteristic) with the transfer impedance removed. This relay zone 2 element (i.e., the blue circle) does not meet PRC-026-1 – Attachment B, Criteria A because it is not completely contained within the power swing stability boundary.

**Table 8. Example Calculation (Transfer Impedance Removed)**

Calculations for the point at 120 degrees with equal source impedances. The total system current equals the line current. See Figure 10.

Eq. (54)	$E_S = \frac{V_{LL} \angle 120^\circ}{\sqrt{3}}$
	$E_S = \frac{230,000 \angle 120^\circ V}{\sqrt{3}}$

## Application Guidelines

<u>Table 8. Example Calculation (Transfer Impedance Removed)</u>			
	$E_S = 132,791 \angle 120^\circ V$		
<u>Eq. (55)</u>	$E_R = \frac{V_{LL} \angle 0^\circ}{\sqrt{3}}$		
	$E_R = \frac{230,000 \angle 0^\circ V}{\sqrt{3}}$		
	$E_R = 132,791 \angle 0^\circ V$		
<u>Given impedance data.</u>			
<u>Given:</u>	$Z_S = 2 + j10 \Omega$	$Z_L = 4 + j20 \Omega$	$Z_R = 4 + j20 \Omega$
<u>Given:</u>	$Z_{TR} = Z_L \times 10^{10} \Omega$		
<u>Total impedance between generators.</u>			
<u>Eq. (56)</u>	$Z_{total} = \frac{(Z_L \times Z_{TR})}{(Z_L + Z_{TR})}$		
	$Z_{total} = \frac{((4 + j20) \Omega \times (4 + j20)^{10} \Omega)}{((4 + j20) \Omega + (4 + j20)^{10} \Omega)}$		
	$Z_{total} = 4 + j20 \Omega$		
<u>Total system impedance.</u>			
<u>Eq. (57)</u>	$Z_{sys} = Z_S + Z_{total} + Z_R$		
	$Z_{sys} = (2 + j10) \Omega + (4 + j20) \Omega + (4 + j20) \Omega$		
	$Z_{sys} = 10 + j50 \Omega$		
<u>Total system current from sending source.</u>			
<u>Eq. (58)</u>	$I_{sys} = \frac{E_S - E_R}{Z_{sys}}$		
	$I_{sys} = \frac{132,791 \angle 120^\circ V - 132,791 \angle 0^\circ V}{10 + j50 \Omega}$		
	$I_{sys} = 4,511 \angle 71.3^\circ A$		

**Table 8. Example Calculation (Transfer Impedance Removed)**

The current as measured by the relay on  $Z_L$  is only the current flowing through that line as determined by using the current divider equation.

Eq. (59) 
$$I_L = I_{sys} \times \frac{Z_{TR}}{Z_L + Z_{TR}}$$

$$I_L = 4,511 \angle 71.3^\circ A \times \frac{(4 + j20)^{10} \Omega}{(4 + j20) \Omega + (4 + j20)^{10} \Omega}$$

$$I_L = 4,511 \angle 71.3^\circ A$$

The voltage as measured by the relay on  $Z_L$  is the voltage drop from the sending source through the sending source impedance.

Eq. (60) 
$$V_S = E_S - (Z_S \times I_{sys})$$

$$V_S = 132,791 \angle 120^\circ V - [(2 + j10 \Omega) \times 4,511 \angle 71.3^\circ A]$$

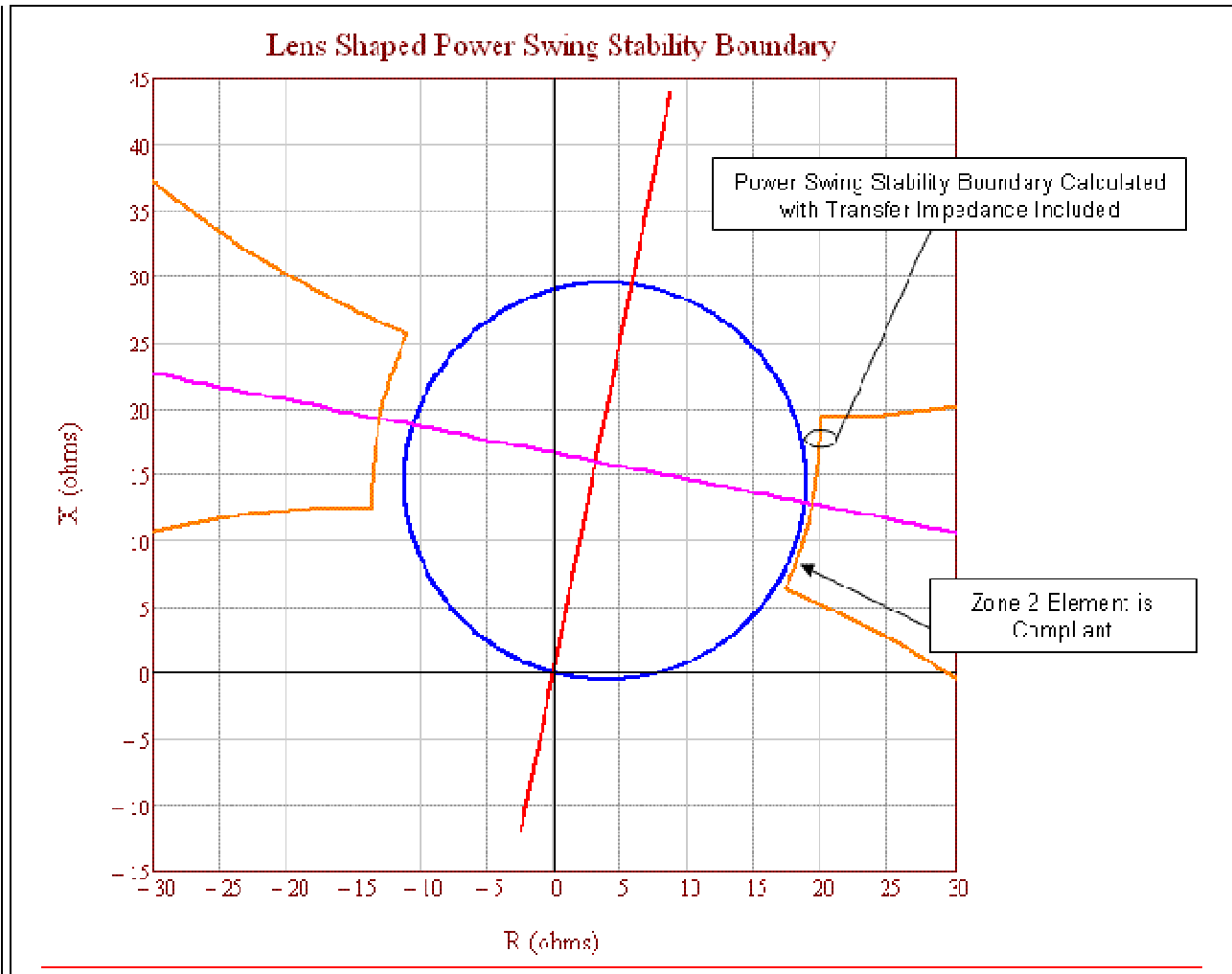
$$V_S = 95,757 \angle 106.1^\circ V$$

The impedance seen by the relay on  $Z_L$ .

Eq. (61) 
$$Z_{L-Relay} = \frac{V_S}{I_L}$$

$$Z_{L-Relay} = \frac{95,757 \angle 106.1^\circ V}{4,511 \angle 71.3^\circ A}$$

$$Z_{L-Relay} = 17.434 + j12.113 \Omega$$



**Figure 11.** This is an example of a power swing stability boundary (i.e., the orange lens characteristic) with the transfer impedance included. The zone 2 element (i.e., the blue circle) meets the PRC-026-1 – Attachment B, Criteria A because it is completely contained within the power swing stability boundary.

In the figure above, the transfer impedance is 5 times the line impedance. The lens characteristic has expanded out beyond the zone 2 element due to the infeed effect from the parallel current through the transfer impedance, thus allowing the zone 2 element to meet PRC-026-1 – Attachment B, Criteria A.



## Application Guidelines

<u>Table 9. Example Calculation (Transfer Impedance Included)</u>			
<u>Calculations for the point at 120 degrees with equal source impedances. The total system current does not equal the line current. See Figure 11.</u>			
<u>Eq. (62)</u>	$E_S = \frac{V_{LL} \angle 120^\circ}{\sqrt{3}}$		
	$E_S = \frac{230,000 \angle 120^\circ V}{\sqrt{3}}$		
	$E_S = 132,791 \angle 120^\circ V$		
<u>Eq. (63)</u>	$E_R = \frac{V_{LL} \angle 0^\circ}{\sqrt{3}}$		
	$E_R = \frac{230,000 \angle 0^\circ V}{\sqrt{3}}$		
	$E_R = 132,791 \angle 0^\circ V$		
<u>Given impedance data.</u>			
<u>Given:</u>	$Z_S = 2 + j10 \Omega$	$Z_L = 4 + j20 \Omega$	$Z_R = 4 + j20 \Omega$
<u>Given:</u>	$Z_{TR} = Z_L \times 5$		
	$Z_{TR} = (4 + j20) \Omega \times 5$		
	$Z_{TR} = 20 + j100 \Omega$		
<u>Total impedance between generators.</u>			
<u>Eq. (64)</u>	$Z_{total} = \frac{(Z_L \times Z_{TR})}{(Z_L + Z_{TR})}$		
	$Z_{total} = \frac{(4 + j20) \Omega \times (20 + j100) \Omega}{(4 + j20) \Omega + (20 + j100) \Omega}$		
	$Z_{total} = 3.333 + j16.667 \Omega$		
<u>Total system impedance.</u>			
<u>Eq. (65)</u>	$Z_{sys} = Z_S + Z_{total} + Z_R$		
	$Z_{sys} = (2 + j10) \Omega + (3.333 + j16.667) \Omega + (4 + j20) \Omega$		

## Application Guidelines

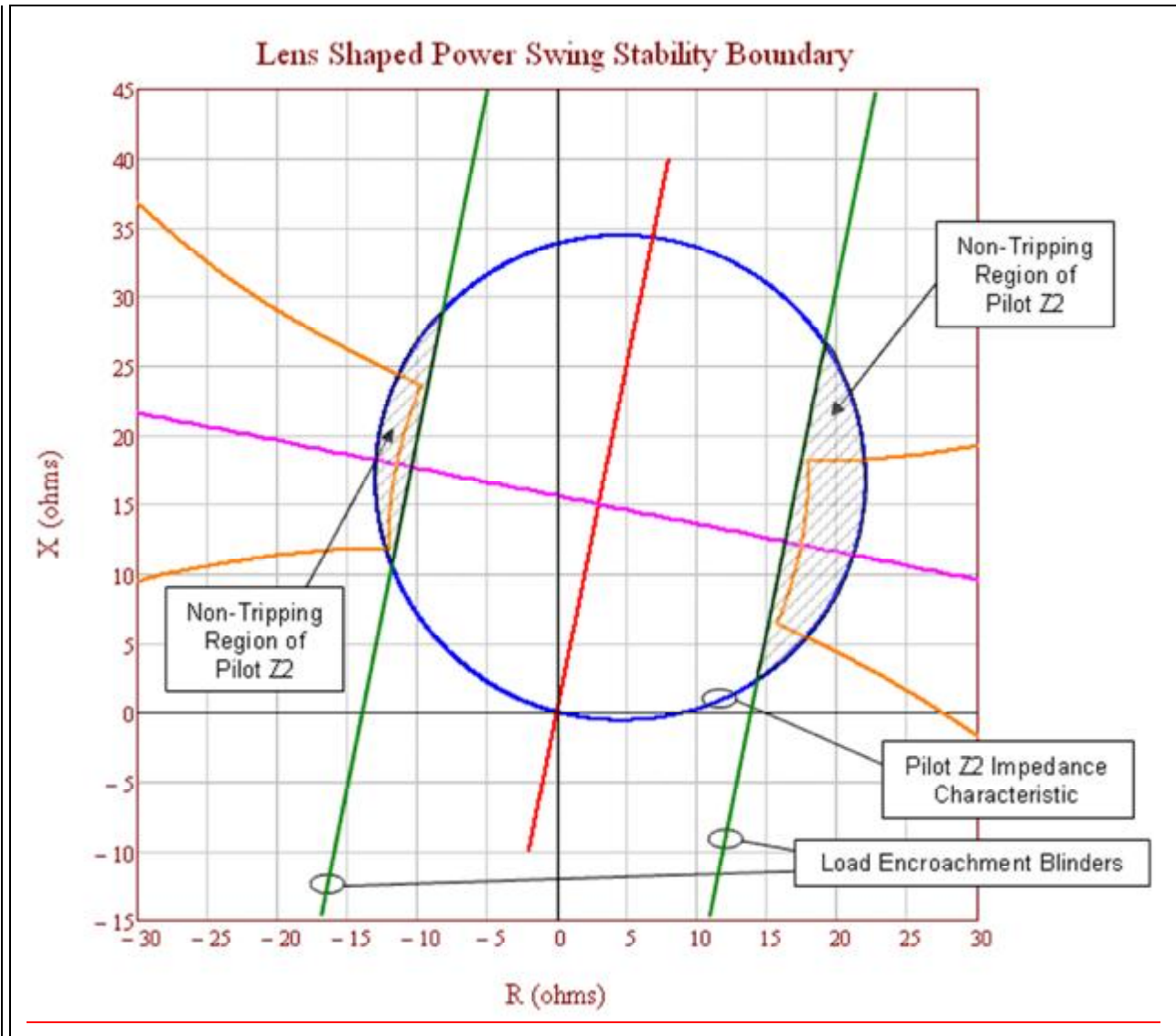
<b>Table 9. Example Calculation (Transfer Impedance Included)</b>	
	$Z_{sys} = 9.333 + j46.667 \Omega$
<u>Total system current from sending source.</u>	
<u>Eq. (66)</u>	$I_{sys} = \frac{E_S - E_R}{Z_{sys}}$
	$I_{sys} = \frac{132,791 \angle 120^\circ V - 132,791 \angle 0^\circ V}{9.333 + j46.667 \Omega}$
	$I_{sys} = 4,832 \angle 71.3^\circ A$
<u>The current as measured by the relay on <math>Z_L</math> is only the current flowing through that line as determined by using the current divider equation.</u>	
<u>Eq. (67)</u>	$I_L = I_{sys} \times \frac{Z_{TR}}{Z_L + Z_{TR}}$
	$I_L = 4,832 \angle 71.3^\circ A \times \frac{(20 + j100) \Omega}{(9.333 + j46.667) \Omega + (20 + j100) \Omega}$
	$I_L = 4,027.4 \angle 71.3^\circ A$
<u>The voltage as measured by the relay on <math>Z_L</math> is the voltage drop from the sending source through the sending source impedance.</u>	
<u>Eq. (68)</u>	$V_S = E_S - (Z_S \times I_{sys})$
	$V_S = 132,791 \angle 120^\circ V - [(2 + j10 \Omega) \times 4,027 \angle 71.3^\circ A]$
	$V_S = 93,417 \angle 104.7^\circ V$
<u>The impedance seen by the relay on <math>Z_L</math>.</u>	
<u>Eq. (69)</u>	$Z_{L-Relay} = \frac{V_S}{I_L}$
	$Z_{L-Relay} = \frac{93,417 \angle 104.7^\circ V}{4,027 \angle 71.3^\circ A}$
	$Z_{L-Relay} = 19.366 + j12.767 \Omega$

## Application Guidelines

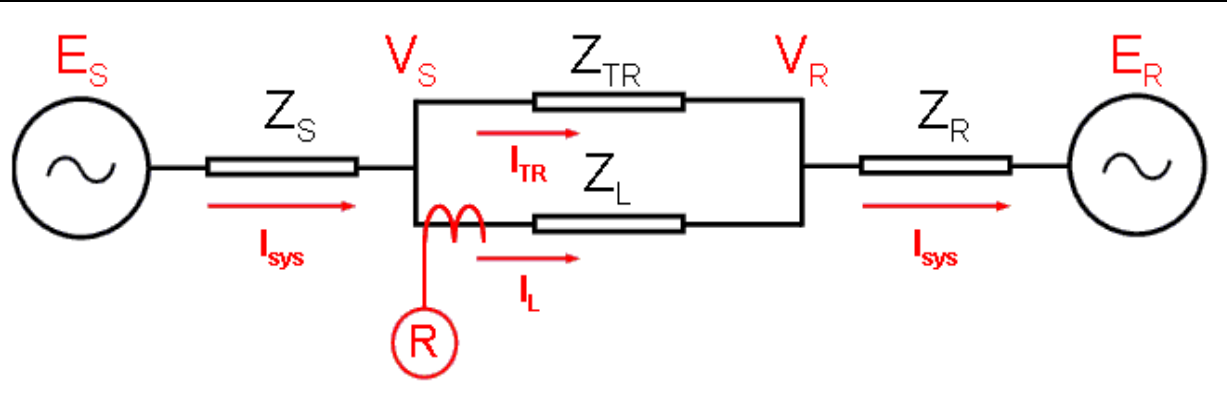
**Table 10. Percent Increase of a Lens Due To Parallel Transfer Impedance.**

The following demonstrates the percent size increase of the lens characteristic for  $Z_{TR}$  in multiples of  $Z_L$  with the transfer impedance included.

<u><math>Z_{TR}</math> in multiples of <math>Z_L</math></u>	<u>Percent increase of lens with equal EMF sources (Infinite source as reference)</u>
<u>Infinite</u>	<u>N/A</u>
<u>1000</u>	<u>0.05%</u>
<u>100</u>	<u>0.46%</u>
<u>10</u>	<u>4.63%</u>
<u>5</u>	<u>9.27%</u>
<u>2</u>	<u>23.26%</u>
<u>1</u>	<u>46.76%</u>
<u>0.5</u>	<u>94.14%</u>
<u>0.25</u>	<u>189.56%</u>



**Figure 12.** The tripping portion not blocked by load encroachment (i.e., the parallel green lines) of the pilot zone 2 element (i.e., the blue circle) is completely contained within the power swing stability boundary (i.e., the orange lens characteristic). Therefore, the zone 2 element meets the [PRC-026-1 – Attachment B, Criteria A](#).



**Figure 13:** The infeed diagram shows the impedance in front of the relay R with the parallel transfer impedance included. As the parallel transfer impedance approaches infinity, the impedances seen by the relay R in the forward direction becomes  $Z_L + Z_R$ .

**Table 11. Calculations (System Apparent Impedance in the forward direction)**

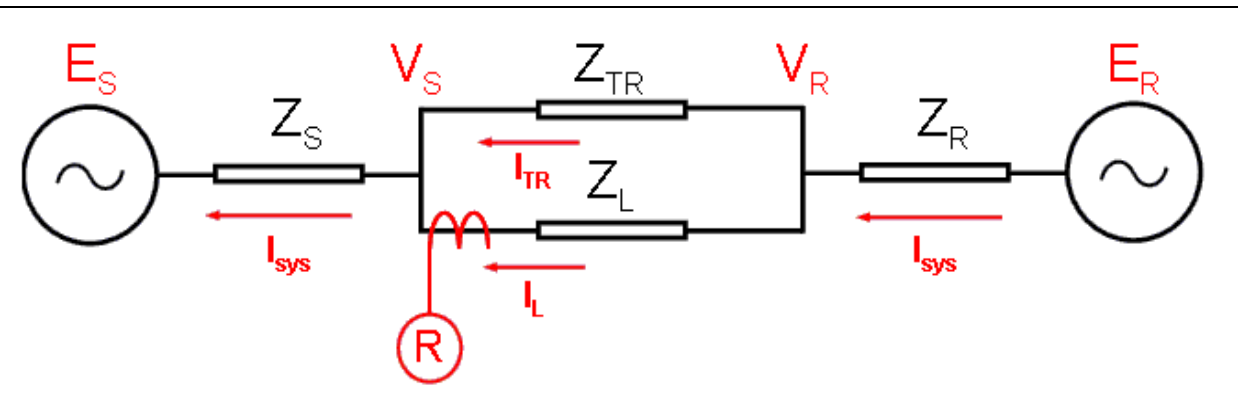
The following equations are provided for calculating the apparent impedance back to the  $E_R$  source voltage as seen by relay R. Infeed equations from  $V_S$  to source  $E_R$  where  $E_R = 0$ . See Figure 13.

Eq. (70)	$I_L = \frac{V_S - V_R}{Z_L}$			
Eq. (71)	$I_{sys} = \frac{V_R - E_R}{Z_R}$			
Eq. (72)	$I_{sys} = I_L + I_{TR}$			
Eq. (73)	$I_{sys} = \frac{V_R}{Z_R}$	Since $E_R = 0$	Rearranged:	$V_R = I_{sys} \times Z_R$
Eq. (74)	$I_L = \frac{V_S - I_{sys} \times Z_R}{Z_L}$			
Eq. (75)	$I_L = \frac{V_S - [(I_L + I_{TR}) \times Z_R]}{Z_L}$			
Eq. (76)	$V_S = (I_L \times Z_L) + (I_L \times Z_R) + (I_{TR} \times Z_R)$			
Eq. (77)	$Z_{Relay} = \frac{V_S}{I_L} = Z_L + Z_R + \frac{I_{TR} \times Z_R}{I_L} = Z_L + Z_R \times \left(1 + \frac{I_{TR}}{I_L}\right)$			

## Application Guidelines

**Table 11. Calculations (System Apparent Impedance in the forward direction)**

Eq. (78)	$I_{TR} = I_{sys} \times \frac{Z_L}{Z_L + Z_{TR}}$
Eq. (79)	$I_L = I_{sys} \times \frac{Z_{TR}}{Z_L + Z_{TR}}$
Eq. (80)	$\frac{I_{TR}}{I_L} = \frac{Z_L}{Z_{TR}}$
<p>The infeed equations shows the impedance in front of the relay R with the parallel transfer impedance included. As the parallel transfer impedance approaches infinity, the impedances seen by the relay R in the forward direction becomes <math>Z_L + Z_R</math>.</p>	
Eq. (81)	$Z_{Relay} = Z_L + Z_R \times \left(1 + \frac{Z_L}{Z_{TR}}\right)$



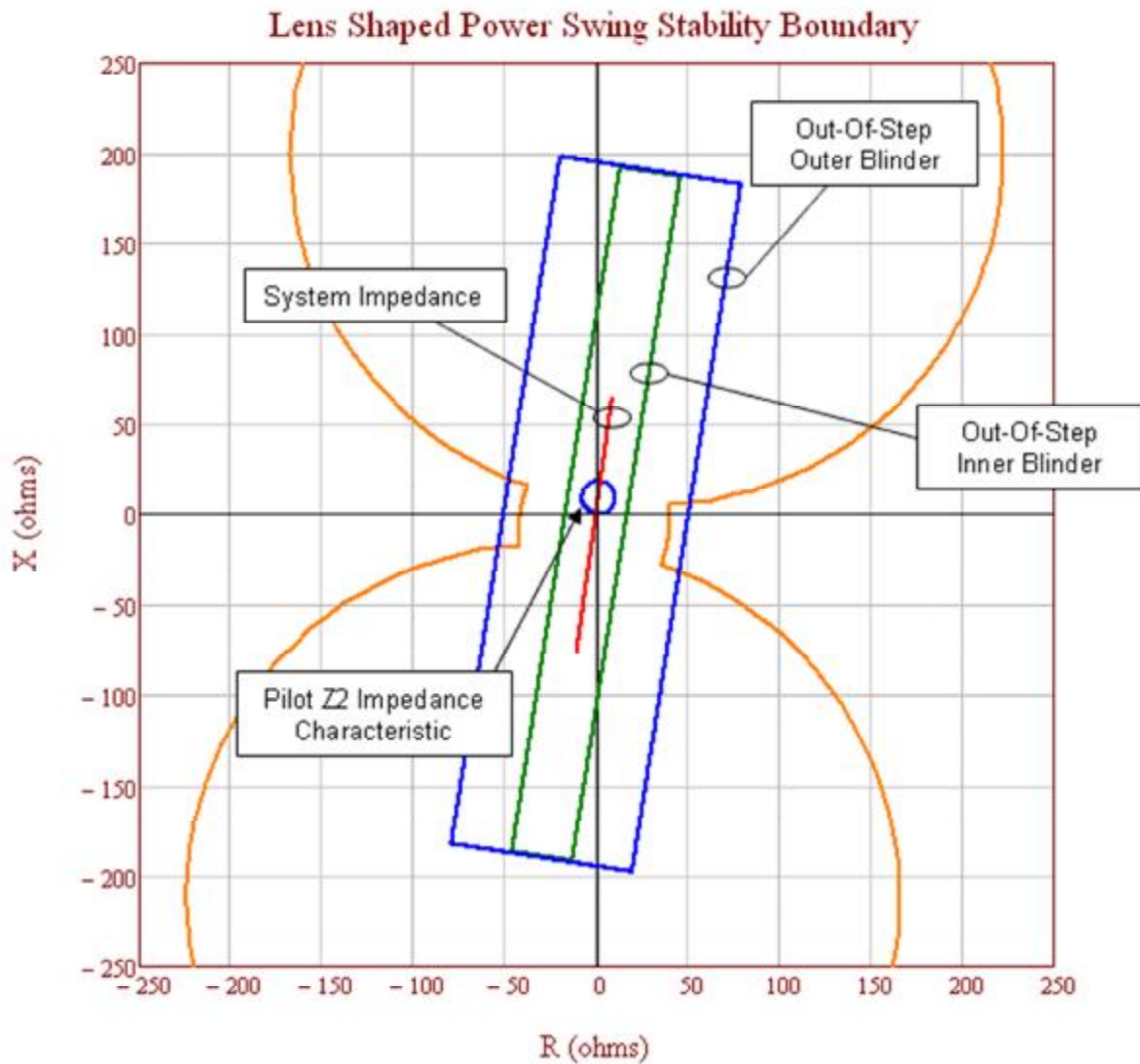
**Figure 14:** The infeed diagram shows the impedance behind relay R with the parallel transfer impedance included. As the parallel transfer impedance approaches infinity, the impedances seen by the relay R in the reverse direction becomes  $Z_S$ .

**Table 12. Calculations (System Apparent Impedance in the reverse direction)**

The following equations are provided for calculating the apparent impedance back to the  $E_S$  source voltage as seen by relay R. Infeed equations from  $V_R$  back to source  $E_S$  where  $E_S \neq 0$ . See Figure 14.

Eq. (82)	$I_L = \frac{V_R - V_S}{Z_L}$
----------	-------------------------------

<b>Table 12. Calculations (System Apparent Impedance in the reverse direction)</b>				
<u>Eq. (83)</u>	$I_{sys} = \frac{V_S - E_S}{Z_S}$			
<u>Eq. (84)</u>	$I_{sys} = I_L + I_{TR}$			
<u>Eq. (85)</u>	$I_{sys} = \frac{V_S}{Z_S}$	<u>Since</u> $E_S = 0$	<u>Rearranged:</u>	$V_S = I_{sys} \times Z_S$
<u>Eq. (86)</u>	$I_L = \frac{V_R - I_{sys} \times Z_S}{Z_L}$			
<u>Eq. (87)</u>	$I_L = \frac{V_R - [(I_L + I_{TR}) \times Z_S]}{Z_L}$			
<u>Eq. (88)</u>	$V_R = (I_L \times Z_L) + (I_L \times Z_S) + (I_{TR} \times Z_{RS})$			
<u>Eq. (89)</u>	$Z_{Relay} = \frac{V_R}{I_L} = Z_L + Z_S + \frac{I_{TR} \times Z_S}{I_L} = Z_L + Z_S \times \left(1 + \frac{I_{TR}}{I_L}\right)$			
<u>Eq. (90)</u>	$I_{TR} = I_{sys} \times \frac{Z_L}{Z_L + Z_{TR}}$			
<u>Eq. (91)</u>	$I_L = I_{sys} \times \frac{Z_{TR}}{Z_L + Z_{TR}}$			
<u>Eq. (92)</u>	$\frac{I_{TR}}{I_L} = \frac{Z_L}{Z_{TR}}$			
<p>The infeed equations shows the impedance behind relay R with the parallel transfer impedance included. As the parallel transfer impedance approaches infinity, the impedances seen by the relay R in the reverse direction becomes <math>Z_S</math>.</p>				
<u>Eq. (93)</u>	$Z_{Relay} = Z_L + Z_S \times \left(1 + \frac{Z_L}{Z_{TR}}\right)$	<u>As seen by relay R at the receiving-end of the line.</u>		
<u>Eq. (94)</u>	$Z_{Relay} = Z_S \times \left(1 + \frac{Z_L}{Z_{TR}}\right)$	<u>Subtract <math>Z_L</math> for relay R impedance as seen at sending-end of the line.</u>		



**Figure 15.** Out-of-step trip (OST) inner blinder (i.e., the parallel green lines) meets the PRC-026-1 – Attachment B, Criteria A because the inner OST blinder initiates tripping either On-The-Way-In or On-The-Way-Out. Since the inner blinder is completely contained within the portion of the power swing stability boundary (i.e., the orange lens characteristic), the zone 2 element (i.e., the blue circle) meets the PRC-026-1 – Attachment B, Criteria A.



## Application Guidelines

**Table 13. Example Calculation (Voltage Ratios)**

These calculations are based on the loss of synchronism characteristics for the cases of  $N < 1$  and  $N > 1$  as found in the *Application of Out-of-Step Blocking and Tripping Relays*, GER-3180, p. 12, Figure 3.<sup>12</sup> The GE illustration shows the formulae used to calculate the radius and center of the circles that make up the ends of the portion of the lens.

Voltage ratio equations, source impedance equation with infeed formulae applied, and circle equations.

<u>Given:</u>	$E_S = 0.7$	$E_R = 1.0$
---------------	-------------	-------------

<u>Eq. (95)</u>	$N_a = \frac{ E_S }{ E_R } = \frac{0.7}{1.0} = 0.7$
-----------------	-----------------------------------------------------

<u>Eq. (96)</u>	$N_b = \frac{ E_R }{ E_S } = \frac{1.0}{0.7} = 1.43$
-----------------	------------------------------------------------------

The total system impedance as seen by the relay with infeed formulae applied.

<u>Given:</u>	$Z_S = 2 + j10 \Omega$	$Z_L = 4 + j20 \Omega$	$Z_R = 4 + j20 \Omega$
---------------	------------------------	------------------------	------------------------

<u>Given:</u>	$Z_{TR} = Z_L \times 10^{10} \Omega$
---------------	--------------------------------------

	$Z_{TR} = (4 + j20)^{10} \Omega$
--	----------------------------------

<u>Eq. (97)</u>	$Z_{sys} = Z_S \times \left(1 + \frac{Z_L}{Z_{TR}}\right) + \left[Z_L + Z_R \times \left(1 + \frac{Z_L}{Z_{TR}}\right)\right]$
-----------------	--------------------------------------------------------------------------------------------------------------------------------

	$Z_{sys} = 10 + j50 \Omega$
--	-----------------------------

The calculated coordinates of the lower circle center.

<u>Eq. (98)</u>	$Z_{C1} = - \left[ Z_S \times \left(1 + \frac{Z_L}{Z_{TR}}\right) \right] - \left[ \frac{N_a^2 \times Z_{sys}}{1 - N_a^2} \right]$
-----------------	------------------------------------------------------------------------------------------------------------------------------------

	$Z_{C1} = - \left[ (2 + j10) \Omega \times \left(1 + \frac{(4 + j20) \Omega}{(4 + j20)^{10} \Omega}\right) \right] - \left[ \frac{0.7^2 \times (10 + j50) \Omega}{1 - 0.7^2} \right]$
--	---------------------------------------------------------------------------------------------------------------------------------------------------------------------------------------

	$Z_{C1} = -11.608 - j58.039 \Omega$
--	-------------------------------------

<sup>12</sup> <http://store.gedigitalenergy.com/faq/Documents/Alps/GER-3180.pdf>

**Table 13. Example Calculation (Voltage Ratios)**

<u>The calculated radius of the lower circle.</u>	
<u>Eq. (99)</u>	$r_a = \left[ \frac{N_a \times Z_{sys}}{1 - N_a^2} \right]$
	$r_a = \left[ \frac{0.7 \times (10 + j50) \Omega}{1 - 0.7^2} \right]$
	$r_a = 69.987 \Omega$
<u>The calculated coordinates of the upper circle center.</u>	
<u>Eq. (100)</u>	$Z_{C2} = Z_L + \left[ Z_R \times \left( 1 + \frac{Z_L}{Z_{TR}} \right) \right] + \left[ \frac{Z_{sys}}{N_b^2 - 1} \right]$
	$Z_{C2} = - \left[ (4 + j20) \Omega \times \left( 1 + \frac{(4 + j20) \Omega}{(4 + j20)^{10} \Omega} \right) \right] + \left[ \frac{(10 + j50) \Omega}{1.43^2 - 1} \right]$
	$Z_{C2} = 17.608 + j88.039 \Omega$
<u>The calculated radius of the upper circle.</u>	
<u>Eq. (101)</u>	$r_b = \left[ \frac{N_b \times Z_{sys}}{N_b^2 - 1} \right]$
	$r_b = \left[ \frac{1.43 \times (10 + j50) \Omega}{1.43^2 - 1} \right]$
	$r_b = 69.987 \Omega$

**Application Specific to Criteria B**

The PRC-026-1 – Attachment B, Criteria B evaluates overcurrent elements used for tripping. The same criteria as PRC-026-1 – Attachment B, Criteria A is used except for an additional criteria (No. 4) that calculates a current magnitude based upon generator terminal voltages of 1.05 per unit. The formula used to calculate the current is as follows:

**Table 14. Example Calculation (Overcurrent)**

This example is for a 230 kV line terminal with a directional instantaneous phase overcurrent element set to 50 amps secondary times a CT ratio of 160:1 that equals 8000 amps on the primary. The following calculation is where  $V_S$  equals the base line-to-ground sending-end generator source voltage times 1.05 at an angle of 120 degrees,  $V_R$  equals the base line-to-ground receiving-end generator terminal voltage times 1.05 at an angle of 0 degrees, and  $Z_{sys}$  equals the sum of the sending-end, line, and receiving-end source impedances in ohms.

Eq. (102)	$V_S = \frac{V_{LL} \angle 120^\circ}{\sqrt{3}} \times 1.05$		
	$V_S = \frac{230,000 \angle 120^\circ V}{\sqrt{3}} \times 1.05$		
	$V_S = 139,430 \angle 120^\circ V$		
<u>Receiving-end generator terminal voltage.</u>			
Eq. (103)	$V_R = \frac{V_{LL} \angle 0^\circ}{\sqrt{3}} \times 1.05$		
	$V_R = \frac{230,000 \angle 0^\circ V}{\sqrt{3}} \times 1.05$		
	$V_R = 139,430 \angle 0^\circ V$		
<u>The total impedance of the system (<math>Z_{sys}</math>) equals the sum of the sending-end source impedance (<math>Z_S</math>), the impedance of the line (<math>Z_L</math>), and receiving-end impedance (<math>Z_R</math>) in ohms.</u>			
Given:	$Z_S = 3 + j26 \Omega$	$Z_L = 1.3 + j8.7 \Omega$	$Z_R = 0.3 + j7.3 \Omega$
Eq. (104)	$Z_{sys} = Z_S + Z_L + Z_R$		
	$Z_{sys} = (3 + j26) \Omega + (1.3 + j8.7) \Omega + (0.3 + j7.3) \Omega$		
	$Z_{sys} = 4.6 + j42 \Omega$		
<u>Total system current from sending source.</u>			
Eq. (105)	$I_{sys} = \frac{(V_S - V_R)}{Z_{sys}}$		
	$I_{sys} = \frac{(139,430 \angle 120^\circ V - 139,430 \angle 0^\circ V)}{(4.6 + j42) \Omega}$		

**Table 14. Example Calculation (Overcurrent)**

$$I_{sys} = 5,715.82 \angle 66.25^\circ A$$

This example is for a 230 kV line terminal with a directional instantaneous phase overcurrent element set to 50 amps-secondary times a CT ratio of 160:1 that equals 8,000 amps-primary. Here, the phase instantaneous setting of 8,000 amps is greater than the calculated system current of 5,716 amps, therefore it is compliant with PRC-026-1 – Attachment B, Criteria B.

### Application to Generation Elements

~~As with Transmission Elements, the determination of the apparent impedance seen at the generator terminals an Element located at, or near, a generation Facility is complex, especially for cases where there are multiple generators connected power swings due to a high-voltage bus. There are various quantities that are interdependent as the disturbance progresses through the time domain whether it is a stable or unstable power swing quantities. These variances include in quantities are caused by changes in machine internal voltage, speed governor action, voltage regulator action, the reaction of other local generators, and the reaction of other interconnected transmission Elements. A as the event progresses through the time domain. Though transient stability program simulations may be used to determine the apparent impedance for best results, especially verifying load-responsive relay settings,<sup>13,14</sup> Requirement R4, PRC-026-1 – Attachment B, Criteria A and B provides a simplified method for relays that are used for transmission line backup protection. Distance and out-of-step relays that are subject evaluating the load-responsive protective relay's susceptibility to tripping in response to a stable power swings are connected at generator terminals and/or on the high-voltage side of the generator step-up (GSU) transformer. The loss of field relay(s) is connected at the generator terminals swing without requiring stability simulations.~~

~~The In general, the electrical center will be in the transmission system for cases where the generator is connected through a weak transmission system (high external system source impedance). Other cases where the generator is connected through a strong transmission system, the electrical center will could be inside the unit connected zone.<sup>15</sup> In either case, impedance load-responsive protective relays connected at the generator terminals or at the high-voltage side of the generator step-up (GSU) transformer may be subject to operation in response to stable challenged by power swings. Impedance relays used to back-up transmission protection usually have as determined by the Planning Coordinator in Requirement R1 or a time delay trip and are coordinated with local transmission line distance relay protection. Out-of-step relaying subject to a stable power swing may not operate correctly if the settings are not properly applied. If it is anticipated that the electrical center will be in the unit connected zone or the apparent~~

<sup>13</sup> Donald Reimert, *Protective Relaying for Power Generation Systems*, Boca Raton, FL, CRC Press, 2006.

<sup>14</sup> Prabha Kundar, *Power System Stability and Control*, EPRI, McGraw Hill, Inc., 1994.

<sup>15</sup> Ibid, Kundar.

~~impedance would challenge the relay operation, the Transmission Planner must perform transient stability studies to validate the existence of a power swing condition that a generator may experience. The Generator Owner uses the apparent impedance plot in a time domain to verify correct settings~~event documented by an actual Disturbance in Requirement R2 and R3.

~~The simplified method used in the Application to Transmission Owners section is also used here to provide a helpful understanding of a stable power swing on load-responsive protective relays for those cases where the generator is connected to the transmission system and there are no infeed effects to be considered. For cases where infeed affects the apparent impedance (multiple unit connected generators connected to a transmission switchyard), the Generator Owner will provide the unit and relay data to the Transmission Planner for analysis. The quantities used to determine the apparent impedance characteristics are the generator unsaturated generator  $X''_d$ , GSU impedance, transmission line impedance, and the system equivalent. A voltage range of 0.65 to 1.5 should be considered to cover the delay of internal voltage for generators under manual or automatic voltage control.~~

### **Requirement R4**

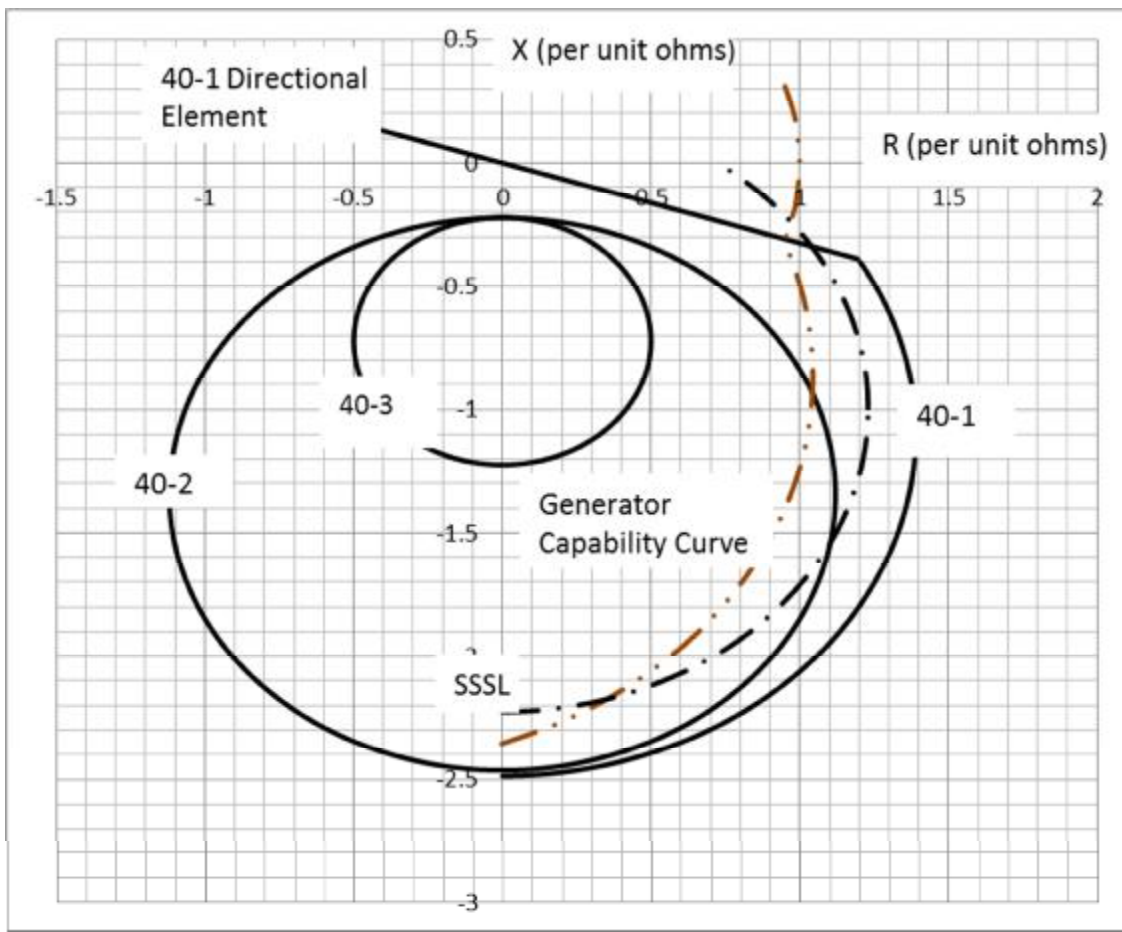
Load-responsive protective relays such as time over-current, voltage controlled time-overcurrent or voltage-restrained time-overcurrent relays are excluded from this standard since they are set based on equipment permissible overload capability. Their operating time is much greater than 15 cycles for the current levels observed during a power swing.

Instantaneous overcurrent and definite-time overcurrent relays with a time delay of less than 15 cycles are included and are required to be evaluated.

The generator loss-of-field protective function is provided by impedance relay(s) connected at the generator terminals. The settings are applied to protect the generator from a partial or complete loss of excitation under all generator loading conditions and, at the same time, be immune to tripping on stable power swings. It is more likely that the relay would operate during a power swing when the automatic voltage regulator (AVR) is in manual mode rather than when in automatic mode.<sup>16</sup> Figure 16 illustrates in the R-X plot, the loss-of-field relays typically include up to three zones of protection.

---

<sup>16</sup> John Burdy, *Loss-of-excitation Protection for Synchronous Generators GER-3183*, General Electric Company.



**Figure 16.** An R-X graph of typical impedance settings for loss-of-field relays.

Loss-of-field characteristic 40-1 has a wider impedance characteristic (positive offset) than characteristic 40-2 or characteristic 40-3 and provides additional generator protection for a partial loss of field or a loss of field under low load (less than 10% of rated). The tripping logic of this protection scheme is established by a directional contact, a voltage setpoint, and a time delay. The voltage and time delay add security to the relay operation for stable power swings. Characteristic 40-3 is less sensitive to power swings than characteristic 40-2 and is set outside the generator capability curve in the leading direction. Regardless of the relay impedance setting, PRC-019 requires that the “in-service limiters operate before Protection Systems to avoid unnecessary trip” and “in-service Protection System devices are set to isolate or de-energize equipment in order to limit the extent of damage when operating conditions exceed equipment capabilities or stability limits.” Time delays for tripping associated with loss-of-field relays<sup>17,18</sup>

<sup>17</sup> Ibid, Burdy.

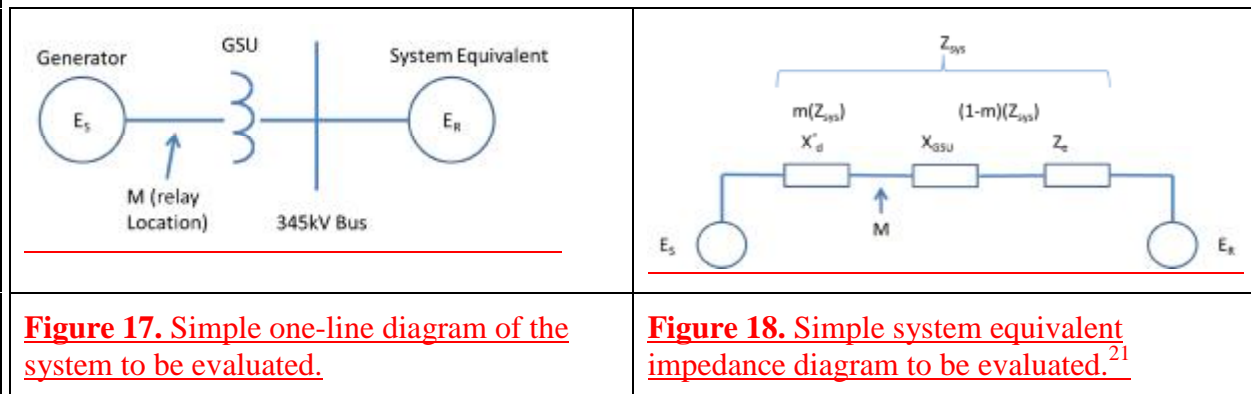
<sup>18</sup> *Applied Protective Relaying*, Westinghouse Electric Corporation, 1979.

## Application Guidelines

have a range from 15 cycles for characteristic 40-2 to 60 cycles for characteristic 40-1 to minimize tripping during stable power swings. In the standard, 15 cycles establishes a threshold for applicability; however, it is the responsibility of the Generator Owner to establish settings that provide security against stable power swings and, at the same time, dependable protection for the generator.

The simple two-machine system circuit (method also used in Transmission Element section) is used to analyze the effect of a power swing at a generator facility for load-responsive relays pursuant to Requirement R4. In this section, the calculation method is used for calculating the impedance seen by the relay connected at a point in the circuit.<sup>19</sup> The electrical quantities used to determine the apparent impedance plot using this method are generator saturated transient reactance ( $X'_d$ ), GSU transformer impedance ( $X_{GSU}$ ), transmission line impedance ( $Z_L$ ), and the system equivalent ( $Z_e$ ) at the point of interconnection. All impedance values are known to the Generator Owner except for the system equivalent. The system equivalent is available from the Transmission Owner. The sending- and receiving-end source voltages are varied from 0.7 to 1.0 per unit to form a portion of a lens characteristic instead of varying the voltages from 0 to 1.0 per unit which would form a full lens characteristic. The voltage range of 0.7 – 1.0 results in a ratio range from 0.7 to 1.43. This ratio range is used in determining the portion of the lens. A system separation angle of 120 degrees is also used in each load-responsive protective relay evaluation.

Below is an example calculation of the apparent impedance locus method based on Figures 18 and 19.<sup>20</sup> In this example, the generator is connected to the 345 kV transmission system through the GSU transformer and has the ratings listed. The load-responsive protective relay responsibilities below are divided between the Generator Owner and Transmission Owner.



<sup>19</sup> Edward Wilson Kimbark, *Power System Stability, Volume II: Power Circuit Breakers and Protective Relays*, Published by John Wiley and Sons, 1950.

<sup>20</sup> Ibid, Kimbark.

<sup>21</sup> Ibid, Kimbark.

## Application Guidelines

<b><u>Table 15. Example Data (Generator)</u></b>	
<b><u>Input Descriptions</u></b>	<b><u>Input Values</u></b>
<u>Synchronous Generator nameplate (MVA)</u>	<b>940 MVA</b>
<u>Sub-transient reactance (940MVA base – per unit)</u>	<b><math>X''_d = 0.3845</math></b>
<u>Generator rated voltage (Line-to-Line)</u>	<b>20 kV</b>
<u>Generator step-up (GSU) transformer rating</u>	<b>880 MVA</b>
<u>GSU transformer reactance (880 MVA base)</u>	<b><math>X_{GSU} = 16.05\%</math></b>
<u>System Equivalent (100 MVA base)</u>	<b><math>Z_e = 0.00723 \angle 86^\circ</math> ohms</b>
<b><u>Generator Owner Load-Responsive Protective Relays</u></b>	
<u>40-1</u>	<b>Positive Offset Impedance</b>
	<b>Offset = 0.294 per unit ohms</b>
	<b>Diameter = 0.294 per unit ohms</b>
<u>40-2</u>	<b>Negative Offset Impedance</b>
	<b>Offset = 0.22 per unit ohms</b>
	<b>Diameter = 2.24 per unit ohms</b>
<u>40-3</u>	<b>Negative Offset Impedance</b>
	<b>Offset = 0.22 per unit ohms</b>
	<b>Diameter = 1.00 per unit ohms</b>
<u>21-1</u>	<b>Diameter = 0.643 per unit ohms</b>
	<b>MTA = 85°</b>
<u>50</u>	<b>I (pickup) = 5.0 per unit</b>
<b><u>Transmission Owned Load-Responsive Protective Relays</u></b>	
<u>21-2</u>	<b>Diameter = 0.55 per unit ohms</b>
	<b>MTA = 85°</b>



## Application Guidelines

Calculations shown for a 120 degree angle and  $E_S/E_R = 1$ . The equation for calculating  $Z_R$  is:<sup>22</sup>

$$\text{Eq. (106)} \quad Z_R = \left( \frac{(1 - m)(E_S \angle \delta) + (m)(E_R)}{E_S \angle \delta - E_R} \right) \times Z_{sys}$$

Where  $m$  is the relay location as a function of the total impedance (real number less than 1)

$E_S$  and  $E_R$  is the sending- and receiving-end voltages

$Z_{sys}$  is the total system impedance

$Z_R$  is the complex impedance at the relay location and plotted on an R-X diagram

All of the above are constants (940 MVA base) while the angle  $\delta$  is varied. Table 16 below contains calculations for a generator using the data listed in Table 15.

**Table 16. Example Calculations (Generator)**

<u>Given:</u>	$X_d'' = j0.3845 \Omega$	$X_{GSU} = j0.171 \Omega$	$Z_e = 0.06796 \Omega$
<u>Eq. (107)</u>	$Z_{sys} = X_d'' + X_{GSU} + Z_e$		
	$Z_{sys} = j0.3845 \Omega + j0.171 \Omega + 0.06796 \Omega$		
	$Z_{sys} = 0.6239 \angle 90^\circ \Omega$		
<u>Eq. (108)</u>	$m = \frac{X_d''}{Z_{sys}} = \frac{0.3845}{0.6239} = 0.61633$		
<u>Eq. (109)</u>	$Z_R = \left( \frac{(1 - m)(E_S \angle \delta) + (m)(E_R)}{E_S \angle \delta - E_R} \right) \times Z_{sys}$		
	$Z_R = \left( \frac{(1 - 0.61633) \times (1 \angle 120^\circ) + (0.61633)(1 \angle 0^\circ)}{1 \angle 120^\circ - 1 \angle 0^\circ} \right) \times (0.6234 \angle 90^\circ) \Omega$		
	$Z_R = \left( \frac{0.4244 + j0.3323}{-1.5 + j 0.866} \right) \times (0.6234 \angle 90^\circ) \Omega$		
	$Z_R = (0.3112 \angle -111.94^\circ) \times (0.6234 \angle 90^\circ) \Omega$		
	$Z_R = 0.194 \angle -21.94^\circ \Omega$		

<sup>22</sup> Ibid, Kimbark.

**Table 16. Example Calculations (Generator)**

$$Z_R = -0.18 - j0.073 \Omega$$

Table 17 lists the swing impedance values at other angles and at  $E_S/E_R = 1, 1.43,$  and  $0.7$ . The impedance values are plotted on an R-X graph with the center being at the generator terminals for use in evaluating impedance relay settings.

**Table 17: Sample calculations for a swing impedance chart for varying voltages at the sending- and receiving-end.**

Angle ( $\delta$ ) (Degrees)	$E_S/E_R=1$		$E_S/E_R=1.43$		$E_S/E_R=0.7$	
	$Z_R$		$Z_R$		$Z_R$	
	Magnitude (PU Ohms)	Angle (Degrees)	Magnitude (PU Ohms)	Angle (Degrees)	Magnitude (PU Ohms)	Angle (Degrees)
90	0.320	-13.1	0.296	6.3	0.344	-31.5
120	0.194	-21.9	0.173	-0.4	0.227	-40.1
150	0.111	-41.0	0.082	-10.3	0.154	-58.4
210	0.111	-25.9	0.082	190.3	0.154	238.4
240	0.111	221.0	0.173	180.4	0.225	220.1
270	0.320	193.1	0.296	173.7	0.344	211.5

**Requirement R4 Generator Examples**

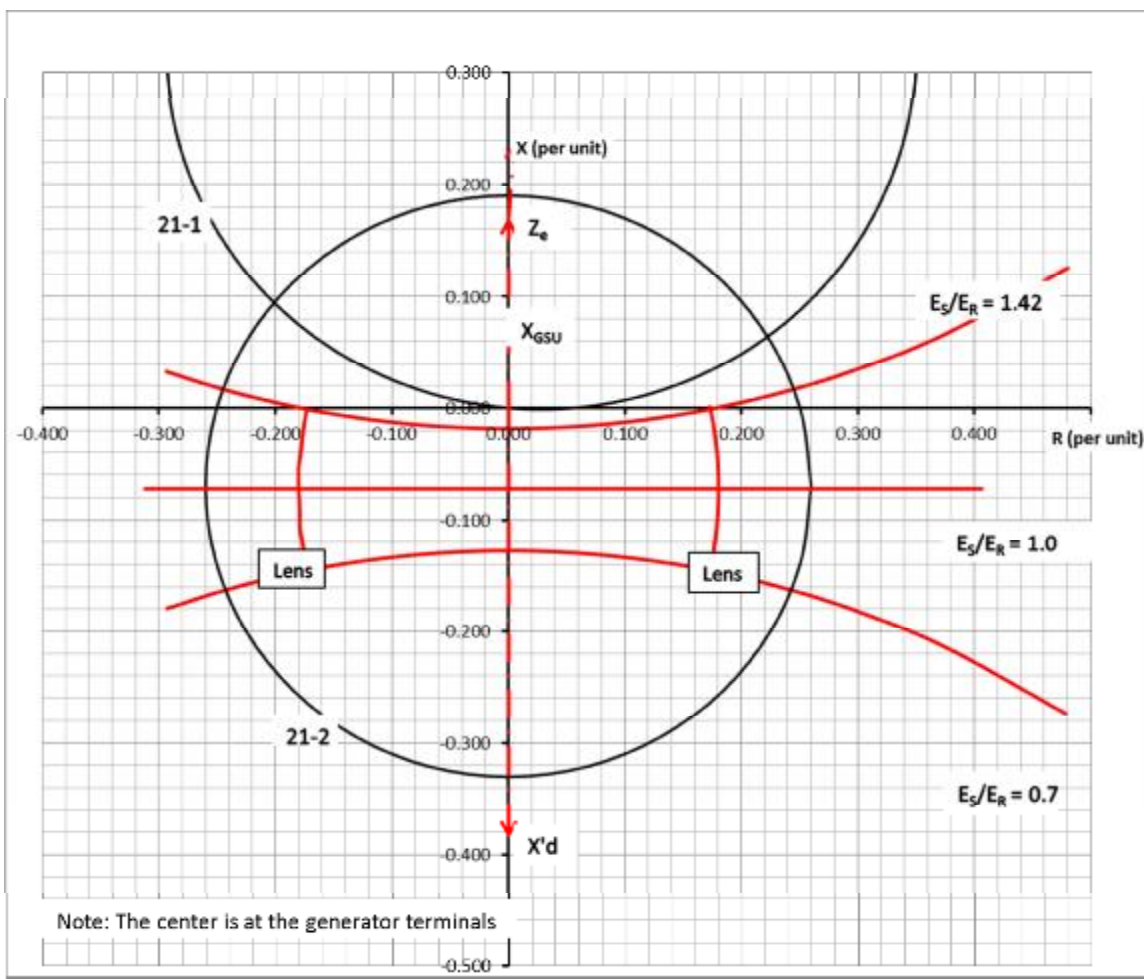
**Distance Relay Application**

Based on PRC-026-1 – Attachment B, Criteria A, the distance relay (21-1) (owned by the generation entity) characteristic is in the region where a stable power swing would not occur as shown in Figure 19. There is no further obligation to the owner in this standard for this load-responsive protective relay.

The distance relay (21-2) (owned by the transmission entity) is connected at the high-voltage side of the GSU transformer and its impedance characteristic is in the region where a stable power swing could occur causing the relay to operate. In this example, if the intentional time delay of this relay is less than 15 cycles, the Transmission Owner is required to create a CAP (Requirement R5) to meet PRC-026 – Attachment B, Criteria B. Some of the options include, but are not limited to, changing the relay setting (i.e. impedance reach, angle, time delay), modify the scheme (i.e. add power swing blocking), or replace the Protection System. Note that the relay

## Application Guidelines

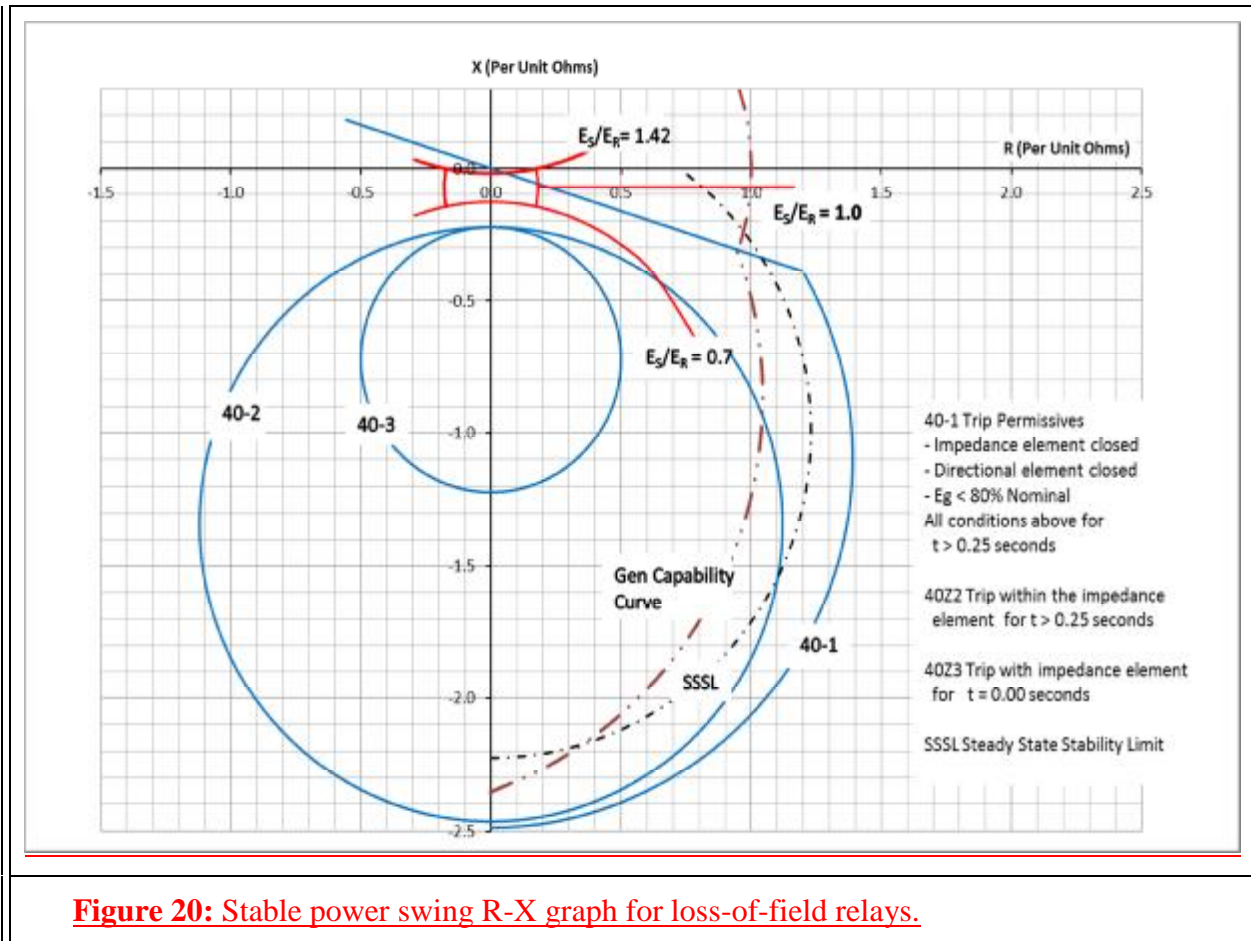
may be excluded from this standard if it has an intentional time delay equal to or greater than 15 cycles.



**Figure 19.** Swing impedance graph for impedance relays at a generating facility.

### **Loss-of-Field Relay Application**

In Figure 20, the R-X diagram shows the loss-of-field relay (40-1 and 40-2) characteristics are in the region where a stable power swing can cause a relay operation. Protective relay 40-1 would be excluded if it has an intentional time delay equal to or greater than 15 cycles. Similarly, 40-2 would be excluded if its intentional time delay is equal to or greater than 15 cycles. For example, if 40-1 has a time delay of 1 second and 40-2 has a time delay of 0.25 seconds, they are excluded and there is no further obligation to the owner in this standard for these relays. The loss-of-field relay characteristic 40-3 is outside the region where a stable power swing can cause a relay operation. In this case, the owner may select high speed tripping on operation of the 40-3 impedance element.



**Instantaneous Overcurrent Relay**

In similar fashion to the transmission overcurrent example calculation in Table 14, the instantaneous overcurrent relay minimum setting is established by PRC-026-1 – Attachment B, Criteria B. The solution is found by:

Eq. (110) 
$$I_{sys} = \frac{E_S - E_R}{Z_{sys}}$$

As stated in the relay settings in Table 15, the relay is installed on the high-voltage side of the GSU transformer with a pickup of 5.0 per unit current. The maximum allowable current is calculated below.

$$I_{sys} = \frac{(1.05 \angle 120^\circ - 1.05 \angle 0^\circ)}{0.6234 \angle 90^\circ} A$$

$$I_{sys} = \frac{1.775 \angle 150^\circ V}{0.6234 \angle 90^\circ \Omega} A$$

$$I_{sys} = 2.84 \angle 60^\circ A$$

## Application Guidelines

---

The phase instantaneous setting of 5.0 per unit amps is greater than the calculated system current of 2.84 per unit amps; therefore it is compliant with PRC-026-1 – Attachment B, Criteria B.

### **Requirement R5**

This requirement ensures that all actions associated with any Corrective Action Plan (CAP) developed in the previous requirement ~~is implemented through completion. Having such are completed. The~~ requirement allows also permits the ~~entity's work toward making protection scheme adjustments measurable given~~ entity to modify a CAP as necessary, while in the variability process of fulfilling the timetable purpose of ~~each CAP~~ the standard.

To achieve the stated purpose of this standard, which is to ensure that relays ~~do are expected to not operate~~ trip in response to stable power swings during non-fault conditions, ~~the responsible entity is required to implement and complete a CAP that addresses the relays that are at risk of tripping during a stable power swing for the~~ Fault conditions, the applicable ~~Elements on~~ entity is required to develop and complete a CAP that reduces the risk of relays tripping during a stable power swing that may occur on any applicable Element of the BES. Protection System owners are required ~~in, during~~ the implementation of a CAP, to update it when actions any action or timetable change, changes until the CAP is completed. Accomplishing this objective is intended to reduce the risk of the relays unnecessarily tripping during stable power swings, thereby improving reliability and reducing risk to the BES.

The following are examples of actions taken to complete CAPs for a relay ~~responding that could be exposed~~ to a stable power swing where and a setting change was determined to be acceptable (without diminishing the ability of the relay to protect for faults within its zone of protection).

**Example R4aR5a:** Actions: Settings were issued on 6/02/~~2014~~2015 to reduce the zone ~~32~~ reach of the ~~KD-10 relay impedance relay used in the permissive overreaching transfer trip (POTT) scheme~~ from 30 ohms to 25 ohms so that the relay characteristic is completely contained within the lens characteristic identified by the criterion. The settings were applied to the relay on 6/25/~~2014~~2015. CAP completed on 06/25/~~2014~~2015.

**Example R4bR5b:** Actions: Settings were issued on 6/02/~~2014~~2015 to enable out-of-step blocking on the ~~SEL-321 existing microprocessor-based~~ relay to prevent tripping in response to stable power swings. The setting changes were applied to the relay on 6/25/~~2014~~2015. CAP completed on 06/25/~~2014~~2015.

## Application Guidelines

---

The following is an example of actions taken to complete a CAP for a relay responding to a stable power swing that required the addition of an ~~out-of-step~~electromechanical power swing blocking relay.

**Example R4eR5c:** Actions: A project for the addition of an ~~out-of-step~~electromechanical power swing blocking relay (~~KS~~) to supervise the zone ~~3-(KD-10)2 impedance~~ relay was initiated on 6/5/~~2014~~2015 to prevent tripping in response to stable power swings. The relay installation was completed on 9/25/~~2014~~2015. CAP completed on 9/25/~~2014~~2015.

The following is an example of actions taken to complete a CAP with a timetable that required updating for the replacement of the relay.

**Example R4dR5d:** Actions: A project for the replacement of the ~~KD-10~~impedance relays at both terminals of line X with ~~GE-L90~~line current differential relays was initiated on 6/5/~~2014~~2015 to prevent tripping in response to stable power swings. The completion of the project was postponed due to line outage rescheduling from 11/15/~~2014~~2015 to 3/15/~~2015~~2016. Following the timetable change, the ~~KD-10~~impedance relay replacement was completed on 3/18/~~2015~~2016. CAP completed on 3/18/~~2015~~2016.

The CAP is complete when all the documented actions to resolve the specific problem (i.e., unnecessary tripping during stable power swings) are completed.

### Requirement R6

To achieve the stated purpose of this standard, which is to ensure that load-responsive protective relays are expected to not trip in response to stable power swings during non-Fault conditions, the applicable entity is required to fully implement any CAP developed pursuant to Requirement R5 that modifies the Protection System to meet PRC-026-1 – Attachment B, Criteria A and B. Protection System owners are required in the implementation of a CAP to update it when actions or timetable change, until all actions are complete. Accomplishing this objective is intended to reduce the occurrence of Protection System tripping during a stable power swing, thereby improving reliability and minimizing risk to the BES.

# Implementation Plan

## Project 2010-13.3 – Relay Loadability: Stable Power Swings

### Requested Approvals

PRC-026-1 – Relay Performance During Stable Power Swings

### Requested Retirements

None.

### Prerequisite Approvals

None.

### General Considerations

There are a number of factors that influence the determination of an implementation period for the new proposed standard. The following factors may be specific to one or more of the applicable entities listed below.

1. The effort and resources for all applicable entities to develop or modify internal processes and/or procedures.
2. The effort and resources for the Planning Coordinator to identify the Element(s) according to the criterion in Requirement R1.
3. The need for the Generator Owner or Transmission Owner to secure resources (e.g., availability of consultants, if needed) to evaluate each load-responsive protective relay's response to a stable power swing for identified Elements.
4. The period of time for a Generator Owner or Transmission Owner to develop a Corrective Action Plan to modify its Protection System.<sup>1</sup>

### Applicable Entities

Generator Owner  
Planning Coordinator  
Transmission Owner

---

<sup>1</sup> The period of time that may be required for a Generator Owner or Transmission Owner to take an Element outage, if necessary, to modify the Protection System is driven through the Corrective Action Plan (CAP) and is independent of the standard's implementation period. The CAP includes its own timetable which is at the discretion of the entity.

**Effective Date****Requirements R1-R3, R5, and R6**

First day of the first full calendar year that is 12 months after the date that the standard is approved by an applicable governmental authority or as otherwise provided for in a jurisdiction where approval by an applicable governmental authority is required for a standard to go into effect. Where approval by an applicable governmental authority is not required, the standard shall become effective on the first day of the first full calendar year that is 12 months after the date the standard is adopted by the NERC Board of Trustees or as otherwise provided for in that jurisdiction.

**Requirement R4**

First day of the first full calendar year that is 36 months after the date that the standard is approved by an applicable governmental authority or as otherwise provided for in a jurisdiction where approval by an applicable governmental authority is required for a standard to go into effect. Where approval by an applicable governmental authority is not required, the standard shall become effective on the first day of the first full calendar year that is 36 months after the date the standard is adopted by the NERC Board of Trustees or as otherwise provided for in that jurisdiction.

**Notifications Prior to the Effective Date of R4**

During the implementation of the standard, notifications are likely to occur prior to Requirement R4 becoming effective. Where notification under R1 or identification under Requirement R2 or R3 occurs prior to the Effective Date of Requirement R4, the 12 month time period in Requirement R4 will begin from the Effective Date of Requirement R4. Thereafter, entities will follow the 12 month time period in R4. The intention of the additional time for R4 to become effective is to handle the initial influx of notifications and identifications.

**Justification**

The implementation plan is based on the general considerations above and provides sufficient time for the Generator Owner, Planning Coordinator, and Transmission Owner to begin becoming compliant with the standard. The Effective date is constructed such that once the standard is adopted or approved it would become effective in the first whole calendar year after approvals that is 12 months for Requirements R1-R3, R5, and R6, and 36 months for Requirement R4.

Requirement R1 – The Planning Coordinator will have at least one full calendar year to prepare itself to identify any Elements that meet the criteria and notify the respective Generator Owner and Transmission Owner of any identified Elements within the allotted timeframe.

Requirement R2 – The Transmission Owner will have at least one year to prepare itself with identifying any Element that trips due to a stable or unstable power swing during an actual system Disturbance due to the operation of its load-responsive protective relays, or any Element that forms the boundary of an island during an actual system Disturbance due to the



operation of its protective relays. This includes providing the applicable notifications to the Planning Coordinator within the allotted timeframe.

Requirement R3 – The Generator Owner will have at least one year to prepare itself with identifying any Element that trips due to a stable or unstable power swing during an actual system Disturbance due to the operation of its load-responsive protective relays. This includes providing the applicable notifications to the Planning Coordinator within the allotted timeframe.

Requirement R4 – The Generator Owner and Transmission Owner will have at least three years to develop internal processes and procedures for evaluating its load-responsive protective relays for an identified Element pursuant to Requirements R1, R2, and R3. Also, both entities are provided an implementation that will allow the entity to conduct initial evaluations of its load-responsive protective relays for an identified Element during the first 36 calendar months of approval.

Requirement R5 – The Generator Owner and Transmission Owner will have at least one year to develop internal processes and procedures for developing a Corrective Action Plan (CAP) for addressing any Protection System for an identified Element that requires modification to meet PRC-206-1 – Attachment B, Criteria A and B.

Requirement R6 – The Generator Owner and Transmission Owner will have at least one year to develop internal processes and procedures for implementing any CAPs developed in Requirement R5.

# Implementation Plan

## Project 2010-13.3 – Relay Loadability: Stable Power Swings

### Requested Approvals

PRC-026-1 – Relay Performance During Stable Power Swings

### Requested Retirements

None.

### Prerequisite Approvals

None.

### General Considerations

There are a number of factors that influence the determination of an implementation period for the new proposed standard. The following factors may be specific to one or more of the applicable entities listed below.

1. The effort and resources for all applicable entities to develop or modify internal processes and/or procedures.
2. The effort and resources for ~~all applicable entities~~ the Planning Coordinator to identify the Element(s) according to the criterion in ~~the Requirements~~ Requirement R1.
3. The need for the Generator Owner or Transmission Owner to secure resources (e.g., availability of consultants, if needed) to evaluate each load-responsive protective relay's response to a stable power swing for identified Elements.
- ~~4. The need for the Generator Owner or Transmission Owner to obtain agreement from the Planning Coordinator, Reliability Coordinator, and Transmission Planner where necessary.~~
- ~~5. The amount of work that the Generator Owner or Transmission Owner will need from a Planning Coordinator or Transmission Planner to perform simulations.~~
- ~~6.4. \_\_\_\_\_ The period of time for a Generator Owner or Transmission Owner to take an Element outage, if necessary, to modify the Protection System is driven through the develop a Corrective Action Plan (CAP) and is independent of the standard's implementation period. The CAP includes to modify its own timetable which is at the discretion of the entity. Protection System.<sup>1</sup>~~

<sup>1</sup> The period of time that may be required for a Generator Owner or Transmission Owner to take an Element outage, if necessary, to modify the Protection System is driven through the Corrective Action Plan (CAP) and is independent of the standard's implementation period. The CAP includes its own timetable which is at the discretion of the entity.

**Applicable Entities**

Generator Owner

Planning Coordinator

~~Reliability Coordinator~~

Transmission Owner

~~Transmission Planner~~**Effective Date****Requirements R1-R3, R5, and R6**

First day of the first full calendar year that is ~~twelve~~12 months ~~beyond~~after the date that ~~this~~the standard is approved by ~~an~~ applicable ~~regulatory authorities, or governmental authority or as otherwise provided for in those jurisdictions~~a jurisdiction where regulatory approval by an applicable governmental authority is required for a standard to go into effect. Where approval by an applicable governmental authority is not required, the standard becomes~~shall become~~ effective on the first day of the first full calendar year that is ~~twelve~~12 months ~~beyond~~after the date ~~this~~the standard is ~~approved~~adopted by the NERC Board of Trustees, ~~or as otherwise made~~provided for in that jurisdiction.

**Requirement R4**

First day of the first full calendar year that is 36 months after the date that the standard is approved by an applicable governmental authority or as otherwise provided for in a jurisdiction where approval by an applicable governmental authority is required for a standard to go into effect. Where approval by an applicable governmental authority is not required, the standard shall become effective pursuant on the first day of the first full calendar year that is 36 months after the date the standard is adopted by the NERC Board of Trustees or as otherwise provided for in that jurisdiction.

**Notifications Prior to the** ~~laws applicable~~ **Effective Date of R4**

During the implementation of the standard, notifications are likely to such ERO governmental authorities occur prior to Requirement R4 becoming effective. Where notification under R1 or identification under Requirement R2 or R3 occurs prior to the Effective Date of Requirement R4, the 12 month time period in Requirement R4 will begin from the Effective Date of Requirement R4. Thereafter, entities will follow the 12 month time period in R4. The intention of the additional time for R4 to become effective is to handle the initial influx of notifications and identifications.

**Justification**

The implementation plan is based on the general considerations above and provides ~~a minimum of one full calendar year sufficient time~~ for the Generator Owner, Planning Coordinator, ~~Reliability Coordinator, and~~ Transmission Owner, ~~and Transmission Planner~~ to begin ~~the annual cycle of~~ becoming compliant with the standard ~~regardless of the approval timing by the applicable NERC Board of~~

Trustees or ERO governmental authorities. For example, if. The Effective date is constructed such that once the standard is adopted or approved on September 1, 2015, the standard would become effective on January 1, 2017 in the first whole calendar year after approvals that is 12 months for Requirements R1-R3, R5, and R6, and 36 months for Requirement R4.

Requirement R1 – The Planning Coordinator will have at least one full calendar year to prepare itself to identify any Elements that meet the criteria and notify the respective Generator Owner and Transmission Owner of any identified Elements within the allotted timeframe.

Requirement R2 – The Transmission Owner will have at least one year to prepare itself with identifying any Element that trips due to a stable or unstable power swing during an actual system Disturbance due to the operation of its load-responsive protective relays, or any Element that forms the boundary of an island during an actual system Disturbance due to the operation of its protective relays. This includes providing the applicable notifications to the Planning Coordinator within the allotted timeframe.

Requirement R3 – The Generator Owner will have at least one year to prepare itself with identifying any Element that trips due to a stable or unstable power swing during an actual system Disturbance due to the operation of its load-responsive protective relays. This includes providing the applicable notifications to the Planning Coordinator within the allotted timeframe.

Requirement R4 – The Generator Owner and Transmission Owner will have at least three years to develop internal processes and procedures for evaluating its load-responsive protective relays for an identified Element pursuant to Requirements R1, R2, and R3. Also, both entities are provided an implementation that will allow the entity to conduct initial evaluations of its load-responsive protective relays for an identified Element during the first 36 calendar months of approval.

Requirement R5 – The Generator Owner and Transmission Owner will have at least one year to develop internal processes and procedures for developing a Corrective Action Plan (CAP) for addressing any Protection System for an identified Element that requires modification to meet PRC-206-1 – Attachment B, Criteria A and B.

Requirement R6 – The Generator Owner and Transmission Owner will have at least one year to develop internal processes and procedures for implementing any CAPs developed in Requirement R5.

## Unofficial Comment Form

### Project 2010-13.3 – Relay Loadability: Stable Power Swings

Please **DO NOT** use this form for submitting comments. Please use the electronic form [electronic form](#) to submit comments on the Standard. The electronic comment form must be completed by **8:00 p.m. EST Monday October 6, 2014**.

If you have questions please contact Scott Barfield-McGinnis, Standards Developer at [scott.barfield@nerc.net](mailto:scott.barfield@nerc.net) or by telephone at 404-446-9689.

<http://www.nerc.com/pa/Stand/Pages/Project2010133Phase3of-RelayLoadabilityStablePowerSwings.aspx>

#### Background Information

This posting is soliciting formal comment.

This is Phase 3 of a three-phased standard development that is focused on developing a new Reliability Standard, PRC-026-1 – Relay Performance During Stable Power Swings, to address protective relay operations due to stable power swings. The March 18, 2010, FERC Order No. 733, approved Reliability Standard PRC-023-1 – Transmission Relay Loadability. In this Order, FERC directed NERC to address three areas of relay loadability that include modifications to the approved PRC-023-1, development of a new Reliability Standard to address generator protective relay loadability, and a new Reliability Standard to address the operation of protective relays due to stable power swings. This project's SAR addresses these directives with a three-phased approach to standard development.

Phase 1 focused on making the specific modifications to PRC-023-1 and was completed in the approved Reliability Standard PRC-023-2, which became mandatory on July 1, 2012. Phase 2 focused on developing a new Reliability Standard, PRC-025-1 – Generator Relay Loadability, to address generator protective relay loadability; Phase 2 is currently awaiting regulatory approval. This Phase 3 of the project focuses on developing a new Reliability Standard, PRC-026-1 – Relay Performance During Stable Power Swings, to address protective relay operations due to stable power swings. This Reliability Standard will establish requirements aimed at preventing protective relays from tripping unnecessarily due to stable power swings by requiring the Transmission Owners and Generator Owners to assess the security of protective relay systems that are susceptible to operation during power swings, and take actions to improve security for stable power swings where such actions would not compromise dependable operation for faults and unstable power swings.

You do not have to answer all questions. Enter comments in simple text format. Bullets, numbers, and special formatting will not be retained.

## Summary of revisions from Draft 1 to Draft 2

### Purpose Statement

The standard's purpose was revised from ensuring "relays do not trip" to "relays are expected to not trip" ... in response to stable power swings during non-Fault conditions.

### Applicability

The Reliability Coordinator and Transmission Planner were removed from the standard to address concerns about overlap and potential gaps when identifying Elements.

Applicability for the Generator Owner and Transmission Owner was augmented to refer to an appended "Attachment A" which describes load-responsive protective relays that are included in the standard and associated exclusions.

### Requirements

Requirement R1 was revised substantively to remove the Reliability Coordinator and Transmission Planner functions. The drafting team concurred that having the Planning Coordinator as the single source for identifying Elements prevents potential duplication of work and a possible gap should an entity believe another is making the identification and notification. The Requirement now allows a full calendar year to notify the respective Generator Owner and Transmission Owner of an identified Element. This was done to eliminate the burden of providing notification each January. The following are changes to each of the original four criteria and the addition of a fifth criterion.

1. Added "angular" to clarify that this is not referring to other constraints such as voltage. Also replaced "Special Protection System (SPS)" with "Remedial Action Scheme (RAS)" to comport with expected changes to these NERC defined terms.
2. Clarified that criterion 2 applies only to "monitored" Elements of a System Operating Limit (SOL). Also, added "angular" to clarify that this is not referring to other constraints such as voltage.
3. Revised the "islanding" criterion to remove ambiguity about islands that formed during planning assessments. Islanding is now associated with an Element that forms the boundary of an island due to angular instability within an underfrequency load shedding (UFLS) assessment. Also, added "angular" to clarify that this is not referring to other constraints such as voltage.
4. Replaced the term "Disturbance," because it generally refers to an actual and not simulated event, with the phrase "simulated disturbance." The lowercase term "disturbance" was considered to be consistent with the new TPL-001-4 standard, but it was determined that its usage would continue

to create questions so “simulated” was added. The phrase “stable or unstable” was inserted to clarify that both are applicable to power swings because the goal of the standard is to identify Elements susceptible to either.

5. This criterion was added as a mechanism to require the Planning Coordinator to continue identifying any Element previously reported by a Generator Owner due to a stable or unstable power swing during an actual system Disturbance or the Transmission Owner due to a stable or unstable power swing during an actual system Disturbance or islanding event. Reported Elements will continue to be identified by the Planning Coordinator until the Planning Coordinator determines the Element is no longer susceptible to power swings.

Requirement R2 was revised to remove the Generator Owner performance because the Generator Owner does not “island.” Also, the January 1, 2003 date was removed due to industry confusion and concern about compliance with such a date and how enforcement would be handled should an entity not have good records. In order to maintain continuity of actual Disturbances and to raise awareness of power swing and islanding events, the Transmission Owner is required to report the affected Element to its Planning Coordinator. The only timeframe assigned to the Requirement is following the identification of the Disturbance which was due to a stable or unstable power swing for reporting to the Planning Coordinator. There is no requirement to review the Protection System operation as such activities are addressed by other NERC Reliability Standards.

Requirement R3 is a new requirement created from the previous Requirement R2 specifically for the Generator Owner. In order to maintain continuity of actual Disturbances and to raise awareness of power swing events, the Generator Owner is required to report the affected Element to its Planning Coordinator. The only timeframe assigned to the Requirement is following the identification of the Disturbance which was due to a stable or unstable power swing for reporting to the Planning Coordinator. There is no requirement to review the Protection System operation as such activities are addressed by other NERC Reliability Standards.

Requirement R4 (previously R3) has been rewritten substantially to eliminate multiple and varying activities such as, demonstrate, develop, and obtain agreement. The Requirement was further simplified to reference PRC-026-1 – Attachment B which contains the criteria for evaluating load-responsive protective relays by the Generator Owner and Transmission Owner. The timing for evaluating load-responsive protective relays, initially, is 12 full calendar month. As identified Elements are reported year after year, the Generator Owner and Transmission Owner are only required to re-evaluate its load-responsive protective relays applied on the terminals of the identified Element where the previous evaluation had not been performed in the last three calendar years. This reduced the burden to the entities over Draft 1.

Requirement R5 was added to address the requirement for developing a Corrective Action Plan (CAP) that was contained in the previous Draft 1, Requirement R3.

Requirement R6 was previously R4 and only received comportsing updates to references due to numbering changes.

### PRC-026-1 – Attachment A

The PRC-026-1 – Attachment A was added to the standard due to stakeholder confusion about load-responsive protective relays and to provide specific exclusions. The attachment is referenced in the Applicability section of the standard.

### PRC-026-1 – Attachment B

The PRC-026-1 – Attachment B was added to the standard to remove the “Criteria” for evaluating load-responsive protective relays from within Requirement R4 and provide it in a self-contained place for referencing by Requirement R4. Among other things, the criteria found in the attachment received these modifications:

1. The sending and receiving voltages were changed to 0.7 to 1.0 from 0 to 1.0 per unit. This increases the lens characteristic that the impedance characteristic (e.g., zone 2) must be completely contained within. It was determined that using the 0.7 per unit is not in conflict with other NERC Reliability Standards or accepted industry practice for setting protective relays.
2. In developing the lens characteristic formed in the impedance (R-X) plane that connects the endpoints of the total system impedance, the criteria now requires the “parallel transfer impedance” to be removed.
3. Although previously addressed within the standards’ Application Guidelines, criteria as to whether the transient or sub-transient may be used are now specified. The criteria are further defined as the “saturated (transient or sub-transient) reactance. The option to use either transient or sub-transient is provided to entities because either will provide a lens characteristic that is sufficiently conservative to determine the relay’s susceptibility to tripping in response to a stable power swing. Also, providing this option reduces the burden on entities from changing which value it uses when it is already using one or the other preset in software applications. Saturated reactances are specified since they result in lower system impedances. Most notable, the criteria now requires the “parallel transfer impedance” to be removed when using the criteria to determine the relay’s susceptibility to tripping in response to a stable power swing.
4. The attachment now includes an additional Criteria B which provides criteria for overcurrent-based protective relays. Like the original criteria for impedance-based relays, it uses the 120 degree system separation angle, all Elements in service, and saturated (transient or sub-transient) reactance. This criteria also requires the “parallel transfer impedance” to be removed.

### **You do not have to answer all questions. Enter All Comments in Simple Text Format.**

Please note that the official comment form **does not** retain formatting (even if it appears to transfer formatting when you copy from the unofficial Word version of the form into the official electronic



comment form). If you enter extra carriage returns, bullets, automated numbering, symbols, bolding, italics, or any other formatting, that formatting will not be retained when you submit your comments.

- Separate discrete comments by idea, e.g., preface with (1), (2), etc.
- Use brackets [] to call attention to suggested inserted or deleted text.
- Insert a “check” mark in the appropriate boxes by double-clicking the gray areas.
- **Do not use** formatting such as extra carriage returns, bullets, automated numbering, bolding, or italics.
- **Please do not repeat other entity’s comments.** Select the appropriate item to support another entity’s comments. An opportunity to enter additional or exception comments will be available.
- If supporting other’s comments, be sure the other party submits comments.

## Questions

1. Do you agree with the Applicability changes to PRC-026-1 (e.g., removal of the Reliability Coordinator and Transmission Planner)? If not, please explain why an entity is not appropriate and/or suggest an alternative that should identify the Elements according to the criteria.

Yes

No

Comments:

2. Do you agree that the revisions to Requirement R1 improved clarity while remaining consistent with the focused approach of using the Criteria which came from recommendations in the PSRPS technical document<sup>1</sup> (pg. 21 of 61)? If not, please explain why and provide an alternative, if any.

Yes

No

Comments:

3. The previous Requirement R2 was split into Requirement R2 for the Transmission Owner and Requirement R3 for the Generator Owner in order to clarify the performance for identifying Elements that trip. Did this revision improve the understanding of what is required? If not, please explain why the Requirement(s) need additional clarification.

Yes

No

Comments:

---

<sup>1</sup> NERC System Protection and Control Subcommittee, *Protection System Response to Power Swings*, August 2013, “PSRPS Report,” [http://www.nerc.com/comm/PC/System%20Protection%20and%20Control%20Subcommittee%20SPCS%2020/SPCS%20Power%20Swing%20Report\\_Final\\_20131015.pdf](http://www.nerc.com/comm/PC/System%20Protection%20and%20Control%20Subcommittee%20SPCS%2020/SPCS%20Power%20Swing%20Report_Final_20131015.pdf)

4. Requirement R4 (previously R3) contained multiple activities (e.g., demonstrate, develop a Corrective Action Plan, obtain agreement) and was ambiguous. Do you agree that the revision to Requirement R4 now provides a clearer understanding of what is required by the Generator Owner and Transmission Owner for an identified Element? Note: The Criterion is now found in PRC-026-1 – Attachment B, Criteria A and B. If not, please explain why the Requirement is not clear.

Yes

No

Comments:

5. The new Requirement R5 (previously R4) and the new Requirement R6 address Corrective Action Plans (CAP), if any. Do you agree this is an improvement over having the development of the CAP comingled with other Requirement? If not, please explain.

Yes

No

Comments:

6. Does the “Application Guidelines and Technical Basis” provide sufficient guidance, basis for approach, and examples to support performance of the requirements? If not, please provide specific detail that would improve the Guidelines and Technical Basis.

Yes

No

Comments:

7. The Implementation Plan for the proposed standard has been revised, based on comments, to account for factors such as the initial influx of identified Elements and ongoing burden of entities to identify Elements and re-evaluate Protection Systems. Does the implementation plan provide sufficient time for implementing the standard? If not, please provide a justification for changing the proposed implementation period and for which Requirement.

Yes

No

Comments:

8. If you have any other comments on PRC-026-1 that have not been stated above, please provide them here:

Comments:

# Violation Risk Factors and Violation Severity Level Justifications

Project 2010-13.3 – Relay Loadability: Stable Power Swings  
(PRC-026-1 – Relay Performance During Stable Power Swings)

## Violation Risk Factor and Violation Severity Level Justifications

This document provides the drafting team's justification for assignment of violation risk factors (VRFs) and violation severity levels (VSLs) for each requirement in: PRC-026-1 – Relay Performance During Stable Power Swings.

Each primary requirement is assigned a VRF and a set of one or more VSLs. These elements support the determination of an initial value range for the Base Penalty Amount regarding violations of requirements in FERC-approved Reliability Standards, as defined in the ERO Sanction Guidelines.

The Protection System Response to Power Swings Standard Drafting Team applied the following NERC criteria and FERC Guidelines when proposing VRFs and VSLs for the requirements under this project.

### NERC Criteria - Violation Risk Factors

#### *High Risk Requirement*

A requirement that, if violated, could directly cause or contribute to bulk electric system instability, separation, or a cascading sequence of failures, or could place the bulk electric system at an unacceptable risk of instability, separation, or cascading failures; or, a requirement in a planning time frame that, if violated, could, under emergency, abnormal, or restorative conditions anticipated by the preparations, directly cause or contribute to bulk electric system instability, separation, or a cascading sequence of failures, or could place the bulk electric system at an unacceptable risk of instability, separation, or cascading failures, or could hinder restoration to a normal condition.

#### *Medium Risk Requirement*

A requirement that, if violated, could directly affect the electrical state or the capability of the bulk electric system, or the ability to effectively monitor and control the bulk electric system. However, violation of a medium risk requirement is unlikely to lead to bulk electric system instability, separation, or cascading failures; or, a requirement in a planning time frame that, if violated, could, under emergency, abnormal, or restorative conditions anticipated by the preparations, directly and adversely affect the electrical state or capability of the bulk electric system, or the ability to effectively monitor, control, or restore the bulk electric system.

However, violation of a medium risk requirement is unlikely, under emergency, abnormal, or restoration conditions anticipated by the preparations, to lead to bulk electric system instability, separation, or cascading failures, nor to hinder restoration to a normal condition.

### ***Lower Risk Requirement***

A requirement that is administrative in nature and a requirement that, if violated, would not be expected to adversely affect the electrical state or capability of the bulk electric system, or the ability to effectively monitor and control the bulk electric system; or, a requirement that is administrative in nature and a requirement in a planning time frame that, if violated, would not, under the emergency, abnormal, or restorative conditions anticipated by the preparations, be expected to adversely affect the electrical state or capability of the bulk electric system, or the ability to effectively monitor, control, or restore the bulk electric system. A planning requirement that is administrative in nature.

### **FERC Violation Risk Factor Guidelines**

The standard drafting team (SDT) also considered consistency with the FERC Violation Risk Factor Guidelines for setting VRFs:<sup>1</sup>

#### **Guideline (1) — Consistency with the Conclusions of the Final Blackout Report**

The Commission seeks to ensure that Violation Risk Factors assigned to Requirements of Reliability Standards in these identified areas appropriately reflect their historical critical impact on the reliability of the Bulk-Power System.

In the VSL Order, FERC listed critical areas (from the Final Blackout Report) where violations could severely affect the reliability of the Bulk-Power System:<sup>2</sup>

- Emergency operations
- Vegetation management
- Operator personnel training
- Protection systems and their coordination
- Operating tools and backup facilities
- Reactive power and voltage control
- System modeling and data exchange
- Communication protocol and facilities
- Requirements to determine equipment ratings
- Synchronized data recorders
- Clearer criteria for operationally critical facilities
- Appropriate use of transmission loading relief

#### **Guideline (2) — Consistency within a Reliability Standard**

<sup>1</sup> North American Electric Reliability Corp., 119 FERC ¶ 61,145, order on reh'g and compliance filing, 120 FERC ¶ 61,145 (2007) (“VRF Rehearing Order”).

<sup>2</sup> Id. at footnote 15.

The Commission expects a rational connection between the sub-Requirement Violation Risk Factor assignments and the main Requirement Violation Risk Factor assignment.

**Guideline (3) – Consistency among Reliability Standards**

The Commission expects the assignment of Violation Risk Factors corresponding to Requirements that address similar reliability goals in different Reliability Standards would be treated comparably.

**Guideline (4) – Consistency with NERC’s Definition of the Violation Risk Factor Level**

Guideline (4) was developed to evaluate whether the assignment of a particular Violation Risk Factor level conforms to NERC’s definition of that risk level.

**Guideline (5) – Treatment of Requirements that Co-mingle More Than One Obligation**

Where a single Requirement co-mingles a higher risk reliability objective and a lesser risk reliability objective, the VRF assignment for such Requirements must not be watered down to reflect the lower risk level associated with the less important objective of the Reliability Standard.

**NERC Criteria - Violation Severity Levels**

Violation Severity Levels (VSLs) define the degree to which compliance with a requirement was not achieved. Each requirement must have at least one VSL. While it is preferable to have four VSLs for each requirement, some requirements do not have multiple “degrees” of noncompliant performance and may have only one, two, or three VSLs.

Violation severity levels should be based on the guidelines shown in the table below:

Lower	Moderate	High	Severe
Missing a minor element (or a small percentage) of the required performance The performance or product measured has significant value as it almost meets the full intent of the requirement.	Missing at least one significant element (or a moderate percentage) of the required performance. The performance or product measured still has significant value in meeting the intent of the requirement.	Missing more than one significant element (or is missing a high percentage) of the required performance or is missing a single vital component. The performance or product has limited value in meeting the intent of the requirement.	Missing most or all of the significant elements (or a significant percentage) of the required performance. The performance measured does not meet the intent of the requirement or the product delivered cannot be used in meeting the intent of the requirement.

***FERC Order on Violation Severity Levels***

In its June 19, 2008 Order on Violation Severity Levels, FERC indicated it would use the following four guidelines for determining whether to approve VSLs:

***Guideline 1: Violation Severity Level Assignments Should Not Have the Unintended Consequence of Lowering the Current Level of Compliance***

Compare the VSLs to any prior Levels of Non-compliance and avoid significant changes that may encourage a lower level of compliance than was required when Levels of Non-compliance were used.

***Guideline 2: Violation Severity Level Assignments Should Ensure Uniformity and Consistency in the Determination of Penalties***

Guideline 2a: A violation of a “binary” type requirement must be a “Severe” VSL.

Guideline 2b: Do not use ambiguous terms such as “minor” and “significant” to describe noncompliant performance.

***Guideline 3: Violation Severity Level Assignment Should Be Consistent with the Corresponding Requirement***

VSLs should not expand on what is required in the requirement.

***Guideline 4: Violation Severity Level Assignment Should Be Based on A Single Violation, Not on A Cumulative Number of Violations***

. . . unless otherwise stated in the requirement, each instance of non-compliance with a requirement is a separate violation. Section 4 of the Sanction Guidelines states that assessing penalties on a per violation per day basis is the “default” for penalty calculations.

VRF and VSL Justifications – PRC-026-1, R1

Proposed VRF	Medium
NERC VRF Discussion	<p>A Violation Risk Factor of Medium is consistent with the NERC VRF Guidelines:                      A failure to identify an Element meeting the criteria prohibits further evaluation of any load-responsive protective relay applied at the terminal of the Element. A load-responsive protective relay that goes without evaluation may not be secure for a stable power swing and could in the planning time frame, under emergency, abnormal, or restorative conditions anticipated by the preparations, directly and adversely affect the electrical state or capability of the bulk electric system, or the ability to effectively monitor, control, or restore the bulk electric system.</p> <p>Identifying an Element that is expected to encounter stable power swings based on prescribed criteria is the first step in ensuring the reliable operation of the BES and in preventing the future severity of Disturbances from affecting a wider area.</p>
FERC VRF G1 Discussion	<p>Guideline 1- Consistency w/ Blackout Report:                      The blackout report and subsequent technical analysis identified that two BPS transmission lines tripped due to protective relay operation in response to stable power swings. The protection system operations on these lines did not contribute significantly to the overall outcome of the August 14, 2003 system disturbance; however, protection system operation during stable powers swings could negatively impact system reliability under different operating conditions. Identifying Elements prone to power swings and the subsequent mitigation of load-responsive protective relays applied at the terminals of these Elements will reduce the likelihood of reoccurrence. This Requirement is consistent with the intent of Recommendation 8: Improve System Protection to Slow or Limit the Spread of Future Cascading Outages. While the actions associated with this recommendation did not focus specifically on this issue, the recommendation does note that “power system protection devices should be set to address the specific condition of concern, such as a fault, out-of-step condition, etc., and should not compromise a power system’s inherent physical capability to slow down or stop a cascading event.”</p>
FERC VRF G2 Discussion	<p>Guideline 2- Consistency within a Reliability Standard:                      The Requirement has a single reliability activity associated with the reliability objective and no sub-Requirement(s) which allows a single VRF to be assigned; therefore no conflict(s) exist.</p>
FERC VRF G3 Discussion	<p>Guideline 3- Consistency among Reliability Standards:</p>



**VRF and VSL Justifications – PRC-026-1, R1**

	The Requirement is consistent with NERC Reliability Standards FAC-014-2, R6 (“...Planning Authority shall identify the subset of multiple contingencies...”) which has a VRF of Medium.
FERC VRF G4 Discussion	<p>Guideline 4- Consistency with NERC Definitions of VRFs:            A failure to identify an Element meeting the criteria prohibits further evaluation of any load-responsive protective relay applied at the terminal of the Element. A load-responsive protective relay that goes without evaluation may not be secure for a stable power swing and could in the planning time frame, under emergency, abnormal, or restorative conditions anticipated by the preparations, directly and adversely affect the electrical state or capability of the bulk electric system, or the ability to effectively monitor, control, or restore the bulk electric system.            Identifying an Element that is expected to encounter stable power swings based on prescribed criteria is the first step in ensuring the reliable operation of the BES and in preventing the future severity of Disturbances from affecting a wider area.</p>
FERC VRF G5 Discussion	<p>Guideline 5- Treatment of Requirements that Co-mingle More than One Obligation:            This Requirement does not co-mingle reliability objectives of differing risk; therefore, the assigned VRF of Medium is consistent.</p>

**Proposed VSL**

Lower	Moderate	High	Severe
The Planning Coordinator identified an Element and provided notification in accordance with Requirement R1, but was less than or equal to 30 calendar days late.	The Planning Coordinator identified an Element and provided notification in accordance with Requirement R1, but was more than 30 calendar days and less than or equal to 60 calendar days late.	The Planning Coordinator identified an Element and provided notification in accordance with Requirement R1, but was more than 60 calendar days and less than or equal to 90 calendar days late.	<p>The Planning Coordinator identified an Element and provided notification in accordance with Requirement R1, but was more than 90 calendar days late.</p> <p>OR</p> <p>The Planning Coordinator failed to identify an Element in accordance with Requirement R1.</p>

VRF and VSL Justifications – PRC-026-1, R1

			OR The Planning Coordinator failed to provide notification in accordance with Requirement R1.
NERC VSL Guidelines	Meets NERC’s VSL Guidelines—There is an incremental aspect to the VSL for tardiness and a binary aspect for failure. The VSL is entity size-neutral because performance is Element-driven and not by the total assets which an entity may have awareness over.		
FERC VSL G1 Violation Severity Level Assignments Should Not Have the Unintended Consequence of Lowering the Current Level of Compliance	The proposed VSL does not lower the current level of compliance because the Requirement is new.		
FERC VSL G2 Violation Severity Level Assignments Should Ensure Uniformity and Consistency in the Determination of Penalties Guideline 2a: The Single Violation Severity Level Assignment Category for "Binary" Requirements Is Not Consistent Guideline 2b: Violation Severity Level Assignments that Contain Ambiguous Language	<p>Guideline 2a: This Requirement is not binary; therefore, this criterion does not apply.</p> <p>Guideline 2b: The proposed VSL does not use any ambiguous terminology, thereby supporting uniformity and consistency in the determination of similar penalties for similar violations.</p>		

**VRF and VSL Justifications – PRC-026-1, R1**

<p>FERC VSL G3 Violation Severity Level Assignment Should Be Consistent with the Corresponding Requirement</p>	<p>The proposed VSL uses similar terminology to that used in the corresponding Requirement, and is therefore consistent with the Requirement.</p>
<p>FERC VSL G4 Violation Severity Level Assignment Should Be Based on A Single Violation, Not on A Cumulative Number of Violations</p>	<p>The VSL is based on a single violation and not cumulative violations.</p>

**VRF and VSL Justifications – PRC-026-1, R2 and R3**

<p><b>Proposed VRF</b></p>	<p><b>Medium</b></p>
<p>NERC VRF Discussion</p>	<p>A Violation Risk Factor of Medium is consistent with the NERC VRF Guidelines: A failure to identify an Element meeting the criteria prohibits further evaluation of any load-responsive protective relay applied at the terminal of the Element. A load-responsive protective relay that goes without evaluation may not be secure for a stable power swing and could in the planning time frame, under emergency, abnormal, or restorative conditions anticipated by the preparations, directly and adversely affect the electrical state or capability of the bulk electric system, or the ability to effectively monitor, control, or restore the bulk electric system. Identifying an Element that is expected to encounter stable power swings based on prescribed criteria is the first step in ensuring the reliable operation of the BES and in preventing the future severity of Disturbances from affecting a wider area.</p>
<p>FERC VRF G1 Discussion</p>	<p>Guideline 1- Consistency w/ Blackout Report: The blackout report and subsequent technical analysis identified that two BPS transmission lines tripped due to protective relay operation in response to stable power swings. The protection system operations</p>

VRF and VSL Justifications – PRC-026-1, R2 and R3

	<p>on these lines did not contribute significantly to the overall outcome of the August 14, 2003 system disturbance; however, protection system operation during stable powers swings could negatively impact system reliability under different operating conditions. Identifying Elements prone to power swings and the subsequent mitigation of load-responsive protective relays applied at the terminals of these Elements will reduce the likelihood of reoccurrence. This Requirement is consistent with the intent of Recommendation 8: Improve System Protection to Slow or Limit the Spread of Future Cascading Outages. While the actions associated with this recommendation did not focus specifically on this issue, the recommendation does note that “power system protection devices should be set to address the specific condition of concern, such as a fault, out-of-step condition, etc., and should not compromise a power system’s inherent physical capability to slow down or stop a cascading event.”</p>
<p>FERC VRF G2 Discussion</p>	<p>Guideline 2- Consistency within a Reliability Standard: The Requirement has a single reliability activity associated with the reliability objective and no sub-Requirement(s) which allows a single VRF to be assigned; therefore no conflict(s) exist.</p>
<p>FERC VRF G3 Discussion</p>	<p>Guideline 3- Consistency among Reliability Standards:</p>
<p>FERC VRF G4 Discussion</p>	<p>Guideline 4- Consistency with NERC Definitions of VRFs: A failure to identify an Element meeting the criteria prohibits further evaluation of any load-responsive protective relay applied at the terminal of the Element. A load-responsive protective relay that goes without evaluation may not be secure for a stable power swing and could in the planning time frame, under emergency, abnormal, or restorative conditions anticipated by the preparations, directly and adversely affect the electrical state or capability of the bulk electric system, or the ability to effectively monitor, control, or restore the bulk electric system. Identifying an Element that is expected to encounter stable power swings based on prescribed criteria is the first step in ensuring the reliable operation of the BES and in preventing the future severity of Disturbances from affecting a wider area.</p>
<p>FERC VRF G5 Discussion</p>	<p>Guideline 5- Treatment of Requirements that Co-mingle More than One Obligation: This Requirement does not co-mingle reliability objectives of differing risk; therefore, the assigned VRF of Medium is consistent.</p>

VRF and VSL Justifications – PRC-026-1, R2 and R3

Proposed VSL			
Lower	Moderate	High	Severe
The Transmission Owner identified an Element and provided notification in accordance with Requirement R2, but was less than or equal to 10 calendar days late.	The Transmission Owner identified an Element and provided notification in accordance with Requirement R2, but was more than 10 calendar days and less than or equal to 20 calendar days late.	The Transmission Owner identified an Element and provided notification in accordance with Requirement R2, but was more than 20 calendar days and less than or equal to 30 calendar days late.	The Transmission Owner identified an Element and provided notification in accordance with Requirement R2, but was more than 30 calendar days late. OR The Transmission Owner failed to identify an Element in accordance with Requirement R2. OR The Transmission Owner failed to provide notification in accordance with Requirement R2.
NERC VSL Guidelines	Meets NERC’s VSL Guidelines—There is an incremental aspect to the VSL for tardiness and a binary aspect for failure. The VSL is entity size-neutral because performance is Element-driven and not by the total assets which an entity may have awareness over.		
FERC VSL G1 Violation Severity Level Assignments Should Not Have the Unintended Consequence of Lowering the Current Level of Compliance	The proposed VSL does not lower the current level of compliance because the Requirement is new.		
FERC VSL G2	Guideline 2a:		

VRF and VSL Justifications – PRC-026-1, R2 and R3

<p>Violation Severity Level Assignments Should Ensure Uniformity and Consistency in the Determination of Penalties          Guideline 2a: The Single Violation Severity Level Assignment Category for "Binary" Requirements Is Not Consistent          Guideline 2b: Violation Severity Level Assignments that Contain Ambiguous Language</p>	<p>This Requirement is not binary; therefore, this criterion does not apply.</p> <p>Guideline 2b:          The proposed VSL does not use any ambiguous terminology, thereby supporting uniformity and consistency in the determination of similar penalties for similar violations.</p>
<p>FERC VSL G3          Violation Severity Level Assignment Should Be Consistent with the Corresponding Requirement</p>	<p>The proposed VSL uses similar terminology to that used in the corresponding Requirement, and is therefore consistent with the Requirement.</p>
<p>FERC VSL G4          Violation Severity Level Assignment Should Be Based on A Single Violation, Not on A Cumulative Number of Violations</p>	<p>The VSL is based on a single violation and not cumulative violations.</p>

VRF and VSL Justifications – PRC-026-1, R4

Proposed VRF	High
NERC VRF Discussion	<p>A Violation Risk Factor of High is consistent with the NERC VRF Guidelines:                      A failure to evaluate that the Protection System is expected to not trip for a stable power swing for an identified Element could, under emergency, abnormal, or restorative conditions anticipated by the preparations, directly cause or contribute to bulk electric system instability, separation, or a cascading sequence of failures, or could place the bulk electric system at an unacceptable risk of instability, separation, or cascading failures, or could hinder restoration to a normal condition.                      If a Protection System is less secure during stable power swings, it increases the risk of tripping should the Protection System be challenged by a power swing.</p>
FERC VRF G1 Discussion	<p>Guideline 1- Consistency w/ Blackout Report:                      The blackout report and subsequent technical analysis identified that two BPS transmission lines tripped due to protective relay operation in response to stable power swings. The protection system operations on these lines did not contribute significantly to the overall outcome of the August 14, 2003 system disturbance. Identifying Elements prone to power swings and the subsequent mitigation of load-responsive protective relays applied at the terminals of these Elements will reduce the likelihood of reoccurrence. This Requirement is consistent with the intent of Recommendation 8: Improve System Protection to Slow or Limit the Spread of Future Cascading Outages. While the actions associated with this recommendation did not focus specifically on this issue, the recommendation does note that “power system protection devices should be set to address the specific condition of concern, such as a fault, out-of-step condition, etc., and should not compromise a power system’s inherent physical capability to slow down or stop a cascading event.”</p>
FERC VRF G2 Discussion	<p>Guideline 2- Consistency within a Reliability Standard:                      The Requirement has a single reliability activity associated with the reliability objective and no sub-Requirement(s) which allows a single VRF to be assigned; therefore no conflict(s) exist.</p>
FERC VRF G3 Discussion	<p>Guideline 3- Consistency among Reliability Standards:                      The Requirement is consistent with NERC Reliability Standard PRC-023-3, R1 “...Each Transmission Owner, Generator Owner, and Distribution Provider shall evaluate relay loadability at 0.85 per unit voltage and a power factor angle of 30 degrees”) which has a VRF of High.</p>

VRF and VSL Justifications – PRC-026-1, R4

<p>FERC VRF G4 Discussion</p>	<p>Guideline 4- Consistency with NERC Definitions of VRFs:                  A failure to ensure the Protection System will not trip in response to a stable power swing for an identified Element could, under emergency, abnormal, or restorative conditions anticipated by the preparations, directly cause or contribute to bulk electric system instability, separation, or a cascading sequence of failures, or could place the bulk electric system at an unacceptable risk of instability, separation, or cascading failures, or could hinder restoration to a normal condition.                  If a Protection System is less secure during stable power swings, it increases the risk of tripping should the Protection System be challenged by a power swing.</p>		
<p>FERC VRF G5 Discussion</p>	<p>Guideline 5- Treatment of Requirements that Co-mingle More than One Obligation:                  This Requirement does not co-mingle reliability objectives of differing risk; therefore, the assigned VRF of Medium is consistent.</p>		
<p>Proposed VSL</p>			
<p>Lower</p>	<p>Moderate</p>	<p>High</p>	<p>Severe</p>
<p>The Generator Owner identified an Element and provided notification in accordance with Requirement R3, but was less than or equal to 10 calendar days late.</p>	<p>The Generator Owner identified an Element and provided notification in accordance with Requirement R3, but was more than 10 calendar days and less than or equal to 20 calendar days late.</p>	<p>The Generator Owner identified an Element and provided notification in accordance with Requirement R3, but was more than 20 calendar days and less than or equal to 30 calendar days late.</p>	<p>The Generator Owner identified an Element and provided notification in accordance with Requirement R3, but was more than 30 calendar days late.                  OR                  The Generator Owner failed to identify an Element in accordance with Requirement R3.                  OR                  The Generator Owner failed to provide notification in accordance with Requirement R3.</p>



VRF and VSL Justifications – PRC-026-1, R4

<p>NERC VSL Guidelines</p>	<p>Meets NERC’s VSL Guidelines—There is an incremental aspect to the VSL for tardiness and a binary aspect for failure. The VSL is entity size-neutral because performance is driven by exception. For example, each identified Element must be evaluated.</p>
<p>FERC VSL G1 Violation Severity Level Assignments Should Not Have the Unintended Consequence of Lowering the Current Level of Compliance</p>	<p>The proposed VSL does not lower the current level of compliance because the Requirement is new.</p>
<p>FERC VSL G2 Violation Severity Level Assignments Should Ensure Uniformity and Consistency in the Determination of Penalties Guideline 2a: The Single Violation Severity Level Assignment Category for "Binary" Requirements Is Not Consistent Guideline 2b: Violation Severity Level Assignments that Contain Ambiguous Language</p>	<p>Guideline 2a: This Requirement is not binary; therefore, this criterion does not apply.</p> <p>Guideline 2b: The proposed VSL does not use any ambiguous terminology, thereby supporting uniformity and consistency in the determination of similar penalties for similar violations.</p>
<p>FERC VSL G3 Violation Severity Level Assignment Should Be Consistent with the Corresponding Requirement</p>	<p>The proposed VSL uses similar terminology to that used in the corresponding Requirement, and is therefore consistent with the Requirement.</p>

**VRF and VSL Justifications – PRC-026-1, R4**

<p>FERC VSL G4 Violation Severity Level Assignment Should Be Based on A Single Violation, Not on A Cumulative Number of Violations</p>	<p>The VSL is based on a single violation and not cumulative violations.</p>
------------------------------------------------------------------------------------------------------------------------------------------------------------	------------------------------------------------------------------------------

**VRF and VSL Justifications – PRC-004-3, R5**

<p><b>Proposed VRF</b></p>	<p><b>Medium</b></p>
<p>NERC VRF Discussion</p>	<p>A Violation Risk Factor of Medium is consistent with the NERC VRF Guidelines: Failure to develop a Corrective Action Plan to modify a Protection System of an identified Element that does not meet the criteria could in the planning time frame, under emergency, abnormal, or restorative conditions anticipated by the preparations, directly and adversely affect the electrical state or capability of the bulk electric system, or the ability to effectively monitor, control, or restore the bulk electric system. An unmitigated Protection System could affect the electrical state or capability of the bulk electric system, or the ability to effectively monitor, control, or restore the bulk electric system.</p>
<p>FERC VRF G1 Discussion</p>	<p>Guideline 1- Consistency w/ Blackout Report: The blackout report and subsequent technical analysis identified that two BPS transmission lines tripped due to protective relay operation in response to stable power swings. The protection system operations on these lines did not contribute significantly to the overall outcome of the August 14, 2003 system disturbance; however, protection system operation during stable powers swings could negatively impact system reliability under different operating conditions. Identifying Elements prone to power swings and the subsequent mitigation of load-responsive protective relays applied at the terminals of these Elements will reduce the likelihood of reoccurrence. This Requirement is consistent with the intent of Recommendation 8: Improve System Protection to Slow or Limit the Spread of Future Cascading Outages. While the actions associated with this recommendation did not focus specifically on this issue, the</p>

VRF and VSL Justifications – PRC-004-3, R5	
	recommendation does note that “power system protection devices should be set to address the specific condition of concern, such as a fault, out-of-step condition, etc., and should not compromise a power system’s inherent physical capability to slow down or stop a cascading event.”
FERC VRF G2 Discussion	Guideline 2- Consistency within a Reliability Standard: This Requirement has a single reliability activity associated with the reliability objective and no sub-Requirement(s) which allows a single VRF to be assigned; therefore no conflict(s) exist.
FERC VRF G3 Discussion	Guideline 3- Consistency among Reliability Standards: This Requirement is consistent with the following Reliability Standards which requiring corrective actions or Corrective Action Plans; PRC-016-0.1, R2 (“...shall take corrective actions to avoid future Misoperations”), PRC-022-1, R1.5 (“For any Misoperation, a Corrective Action Plan...”), and FAC-003, R5 (“...Transmission Owner or applicable Generator Owner shall take corrective action to ensure continued vegetation management”) all three of which have a VRF of Medium.
FERC VRF G4 Discussion	Guideline 4- Consistency with NERC Definitions of VRFs: A Violation Risk Factor of Medium is consistent with the NERC VRF Guidelines: A failure to implement the Corrective Action Plan for a Protection System of an identified Element could in the planning time frame, under emergency, abnormal, or restorative conditions anticipated by the preparations, directly and adversely affect the electrical state or capability of the bulk electric system, or the ability to effectively monitor, control, or restore the bulk electric system. An unmitigated Protection System could contribute to the severity of future disturbances affecting a wider area, or potential equipment damage.
FERC VRF G5 Discussion	Guideline 5- Treatment of Requirements that Co-mingle More than One Obligation: This requirement does not co-mingle reliability objectives of differing risk; therefore, the assigned VRF of Medium is consistent.

VRF and VSL Justifications – PRC-004-3, R5

Proposed VSL			
Lower	Moderate	High	Severe
The Generator Owner or Transmission Owner developed a CAP in accordance with Requirement R5, but in more than 60 calendar days and less than or equal to 70 calendar days.	The Generator Owner or Transmission Owner developed a CAP in accordance with Requirement R5, but in more than 70 calendar days and less than or equal to 80 calendar days.	The Generator Owner or Transmission Owner developed a CAP in accordance with Requirement R5, but in more than 80 calendar days and less than or equal to 90 calendar days.	The Generator Owner or Transmission Owner developed a CAP in accordance with Requirement R5, but in more than 90 calendar days.  OR The Generator Owner or Transmission Owner failed to develop a CAP in accordance with Requirement R5.
NERC VSL Guidelines	Meets NERC’s VSL Guidelines—There is an incremental aspect to the VSL for failing to develop the Corrective Action Plan in a timely fashion and a binary aspect for a complete failure. The VSL is entity size-neutral because performance is driven by the need to mitigate the Protection System so that it is expected to not trip on a stable power swing.		
FERC VSL G1 Violation Severity Level Assignments Should Not Have the Unintended Consequence of Lowering the Current Level	The proposed VSL does not lower the current level of compliance because the Requirement is new.		

VRF and VSL Justifications – PRC-004-3, R5

<p>of Compliance</p>	
<p>FERC VSL G2 Violation Severity Level Assignments Should Ensure Uniformity and Consistency in the Determination of Penalties  Guideline 2a: The Single Violation Severity Level Assignment Category for "Binary" Requirements Is Not Consistent  Guideline 2b: Violation Severity Level Assignments that Contain Ambiguous Language</p>	<p>Guideline 2a: This Requirement is not binary; therefore, this criterion does not apply.  Guideline 2b: This proposed VSL does not use any ambiguous terminology, thereby supporting uniformity and consistency in the determination of similar penalties for similar violations.</p>
<p>FERC VSL G3 Violation Severity Level Assignment Should Be Consistent with the Corresponding Requirement</p>	<p>This proposed VSL uses similar terminology to that used in the corresponding Requirement, and is therefore consistent with this Requirement.</p>
<p>FERC VSL G4 Violation Severity Level Assignment Should Be Based on</p>	<p>The VSL is based on a single violation and not cumulative violations.</p>

VRF and VSL Justifications – PRC-004-3, R5

A Single Violation, Not on A Cumulative Number of Violations

VRF and VSL Justifications – PRC-026-1, R6

Proposed VRF	Medium
NERC VRF Discussion	<p>A Violation Risk Factor of Medium is consistent with the NERC VRF Guidelines:</p> <p>A failure to implement the Corrective Action Plan for modifying a Protection System of an identified Element could in the planning time frame, under emergency, abnormal, or restorative conditions anticipated by the preparations, directly and adversely affect the electrical state or capability of the bulk electric system, or the ability to effectively monitor, control, or restore the bulk electric system.</p> <p>An unmitigated Protection System could affect the electrical state or capability of the bulk electric system, or the ability to effectively monitor, control, or restore the bulk electric system.</p>
FERC VRF G1 Discussion	<p>Guideline 1- Consistency w/ Blackout Report:</p> <p>The blackout report and subsequent technical analysis identified that two BPS transmission lines tripped due to protective relay operation in response to stable power swings. The protection system operations on these lines did not contribute significantly to the overall outcome of the August 14, 2003 system disturbance; however, protection system operation during stable powers swings could negatively impact system reliability under different operating conditions. Identifying Elements prone to power swings and the subsequent mitigation of load-responsive protective relays applied at the terminals of these Elements will reduce the likelihood of reoccurrence. This Requirement is consistent with the intent of Recommendation 8: Improve System Protection to Slow or Limit the Spread of Future Cascading Outages. While the actions associated with this recommendation did not focus specifically on this issue, the</p>

**VRF and VSL Justifications – PRC-026-1, R6**

	recommendation does note that “power system protection devices should be set to address the specific condition of concern, such as a fault, out-of-step condition, etc., and should not compromise a power system’s inherent physical capability to slow down or stop a cascading event.”
FERC VRF G2 Discussion	Guideline 2- Consistency within a Reliability Standard: The Requirement has a single reliability activity associated with the reliability objective and no sub-Requirement(s) which allows a single VRF to be assigned; therefore no conflict(s) exist.
FERC VRF G3 Discussion	Guideline 3- Consistency among Reliability Standards: This Requirement is consistent with the following Reliability Standards which requiring corrective actions or Corrective Action Plans: PRC-016-0.1, R2 (“...shall take corrective actions to avoid future Misoperations”), PRC-022-1, R1.5 (“For any Misoperation, a Corrective Action Plan...”), and FAC-003, R5 (“...Transmission Owner or applicable Generator Owner shall take corrective action to ensure continued vegetation management”) all of which have a VRF of Medium.
FERC VRF G4 Discussion	A Violation Risk Factor of Medium is consistent with the NERC VRF Guidelines: A failure to implement the Corrective Action Plan for a Protection System of an identified Element could in the planning time frame, under emergency, abnormal, or restorative conditions anticipated by the preparations, directly and adversely affect the electrical state or capability of the bulk electric system, or the ability to effectively monitor, control, or restore the bulk electric system. An unmitigated Protection System could contribute to the severity of future disturbances affecting a wider area, or potential equipment damage.
FERC VRF G5 Discussion	Guideline 5- Treatment of Requirements that Co-mingle More than One Obligation: This Requirement does not co-mingle reliability objectives of differing risk; therefore, the assigned VRF of Medium is consistent.

**Proposed VSL**

Lower	Moderate	High	Severe
The responsible entity implemented, but failed to update a CAP, when actions or	N/A	N/A	The responsible entity failed to implement a CAP in accordance with Requirement R4.

VRF and VSL Justifications – PRC-026-1, R6

<p>timetables changed, in accordance with Requirement R4.</p>			
<p>NERC VSL Guidelines</p>	<p>Meets NERC’s VSL Guidelines—There is an incremental aspect to the VSL for failing to update the Corrective Action Plan and a binary aspect for failure to implement. The VSL is entity size-neutral because performance is driven by the need to mitigate the Protection System so that it is expected to not trip on a stable power swing.</p>		
<p>FERC VSL G1 Violation Severity Level Assignments Should Not Have the Unintended Consequence of Lowering the Current Level of Compliance</p>	<p>The proposed VSL does not lower the current level of compliance because the Requirement is new.</p>		
<p>FERC VSL G2 Violation Severity Level Assignments Should Ensure Uniformity and Consistency in the Determination of Penalties Guideline 2a: The Single Violation Severity Level Assignment Category for "Binary" Requirements Is Not Consistent Guideline 2b: Violation Severity Level Assignments that Contain Ambiguous Language</p>	<p>Guideline 2a: This Requirement is not binary; therefore, this criterion does not apply.</p> <p>Guideline 2b: The proposed VSL does not use any ambiguous terminology, thereby supporting uniformity and consistency in the determination of similar penalties for similar violations.</p>		
<p>FERC VSL G3</p>	<p>The proposed VSL uses similar terminology to that used in the corresponding Requirement, and is</p>		



## VRF and VSL Justifications – PRC-026-1, R6

Violation Severity Level Assignment Should Be Consistent with the Corresponding Requirement	therefore consistent with the Requirement.
FERC VSL G4 Violation Severity Level Assignment Should Be Based on A Single Violation, Not on A Cumulative Number of Violations	The VSL is based on a single violation and not cumulative violations.

# Violation Risk Factors and Violation Severity Level Justifications

Project 2010-13.3 – Relay Loadability: Stable Power Swings  
(PRC-026-1 – Relay Performance During Stable Power Swings)

## Violation Risk Factor and Violation Severity Level Justifications

This document provides the drafting team's justification for assignment of violation risk factors (VRFs) and violation severity levels (VSLs) for each requirement in: [PRC-004-3—Protection System Misoperations](#) [026-1 – Relay Performance During Stable Power Swings](#).

Each primary requirement is assigned a VRF and a set of one or more VSLs. These elements support the determination of an initial value range for the Base Penalty Amount regarding violations of requirements in FERC-approved Reliability Standards, as defined in the ERO Sanction Guidelines.

The Protection System [Misoperations](#) [Response to Power Swings](#) Standard Drafting Team applied the following NERC criteria and FERC Guidelines when proposing VRFs and VSLs for the requirements under this project.

### NERC Criteria - Violation Risk Factors

#### *High Risk Requirement*

A requirement that, if violated, could directly cause or contribute to bulk electric system instability, separation, or a cascading sequence of failures, or could place the bulk electric system at an unacceptable risk of instability, separation, or cascading failures; or, a requirement in a planning time frame that, if violated, could, under emergency, abnormal, or restorative conditions anticipated by the preparations, directly cause or contribute to bulk electric system instability, separation, or a cascading sequence of failures, or could place the bulk electric system at an unacceptable risk of instability, separation, or cascading failures, or could hinder restoration to a normal condition.

#### *Medium Risk Requirement*

A requirement that, if violated, could directly affect the electrical state or the capability of the bulk electric system, or the ability to effectively monitor and control the bulk electric system. However, violation of a medium risk requirement is unlikely to lead to bulk electric system instability, separation, or cascading failures; or, a requirement in a planning time frame that, if violated, could, under emergency, abnormal, or restorative conditions anticipated by the preparations, directly and adversely affect the electrical state or capability of the bulk electric system, or the ability to effectively monitor, control, or restore the bulk electric system.

However, violation of a medium risk requirement is unlikely, under emergency, abnormal, or restoration conditions anticipated by the preparations, to lead to bulk electric system instability, separation, or cascading failures, nor to hinder restoration to a normal condition.

### ***Lower Risk Requirement***

A requirement that is administrative in nature and a requirement that, if violated, would not be expected to adversely affect the electrical state or capability of the bulk electric system, or the ability to effectively monitor and control the bulk electric system; or, a requirement that is administrative in nature and a requirement in a planning time frame that, if violated, would not, under the emergency, abnormal, or restorative conditions anticipated by the preparations, be expected to adversely affect the electrical state or capability of the bulk electric system, or the ability to effectively monitor, control, or restore the bulk electric system. A planning requirement that is administrative in nature.

### **FERC Violation Risk Factor Guidelines**

The standard drafting team (SDT) also considered consistency with the FERC Violation Risk Factor Guidelines for setting VRFs:<sup>1</sup>

#### **Guideline (1) — Consistency with the Conclusions of the Final Blackout Report**

The Commission seeks to ensure that Violation Risk Factors assigned to Requirements of Reliability Standards in these identified areas appropriately reflect their historical critical impact on the reliability of the Bulk-Power System.

In the VSL Order, FERC listed critical areas (from the Final Blackout Report) where violations could severely affect the reliability of the Bulk-Power System:<sup>2</sup>

- Emergency operations
- Vegetation management
- Operator personnel training
- Protection systems and their coordination
- Operating tools and backup facilities
- Reactive power and voltage control
- System modeling and data exchange
- Communication protocol and facilities
- Requirements to determine equipment ratings
- Synchronized data recorders
- Clearer criteria for operationally critical facilities
- Appropriate use of transmission loading relief

#### **Guideline (2) — Consistency within a Reliability Standard**

<sup>1</sup> North American Electric Reliability Corp., 119 FERC ¶ 61,145, order on reh'g and compliance filing, 120 FERC ¶ 61,145 (2007) ("VRF Rehearing Order").

<sup>2</sup> Id. at footnote 15.

The Commission expects a rational connection between the sub-Requirement Violation Risk Factor assignments and the main Requirement Violation Risk Factor assignment.

**Guideline (3) – Consistency among Reliability Standards**

The Commission expects the assignment of Violation Risk Factors corresponding to Requirements that address similar reliability goals in different Reliability Standards would be treated comparably.

**Guideline (4) – Consistency with NERC’s Definition of the Violation Risk Factor Level**

Guideline (4) was developed to evaluate whether the assignment of a particular Violation Risk Factor level conforms to NERC’s definition of that risk level.

**Guideline (5) – Treatment of Requirements that Co-mingle More Than One Obligation**

Where a single Requirement co-mingles a higher risk reliability objective and a lesser risk reliability objective, the VRF assignment for such Requirements must not be watered down to reflect the lower risk level associated with the less important objective of the Reliability Standard.

**NERC Criteria - Violation Severity Levels**

Violation Severity Levels (VSLs) define the degree to which compliance with a requirement was not achieved. Each requirement must have at least one VSL. While it is preferable to have four VSLs for each requirement, some requirements do not have multiple “degrees” of noncompliant performance and may have only one, two, or three VSLs.

Violation severity levels should be based on the guidelines shown in the table below:

Lower	Moderate	High	Severe
Missing a minor element (or a small percentage) of the required performance The performance or product measured has significant value as it almost meets the full intent of the requirement.	Missing at least one significant element (or a moderate percentage) of the required performance. The performance or product measured still has significant value in meeting the intent of the requirement.	Missing more than one significant element (or is missing a high percentage) of the required performance or is missing a single vital component. The performance or product has limited value in meeting the intent of the requirement.	Missing most or all of the significant elements (or a significant percentage) of the required performance. The performance measured does not meet the intent of the requirement or the product delivered cannot be used in meeting the intent of the requirement.

***FERC Order on Violation Severity Levels***

In its June 19, 2008 Order on Violation Severity Levels, FERC indicated it would use the following four guidelines for determining whether to approve VSLs:

***Guideline 1: Violation Severity Level Assignments Should Not Have the Unintended Consequence of Lowering the Current Level of Compliance***

Compare the VSLs to any prior Levels of Non-compliance and avoid significant changes that may encourage a lower level of compliance than was required when Levels of Non-compliance were used.

***Guideline 2: Violation Severity Level Assignments Should Ensure Uniformity and Consistency in the Determination of Penalties***

Guideline 2a: A violation of a “binary” type requirement must be a “Severe” VSL.

Guideline 2b: Do not use ambiguous terms such as “minor” and “significant” to describe noncompliant performance.

***Guideline 3: Violation Severity Level Assignment Should Be Consistent with the Corresponding Requirement***

VSLs should not expand on what is required in the requirement.

***Guideline 4: Violation Severity Level Assignment Should Be Based on A Single Violation, Not on A Cumulative Number of Violations***

. . . unless otherwise stated in the requirement, each instance of non-compliance with a requirement is a separate violation. Section 4 of the Sanction Guidelines states that assessing penalties on a per violation per day basis is the “default” for penalty calculations.

VRF and VSL Justifications – PRC-026-1, R1

Proposed VRF	Medium
<p>NERC VRF Discussion</p>	<p>A Violation Risk Factor of Medium is consistent with the NERC VRF Guidelines:            A failure to identify an Element meeting the criteria prohibits further evaluation of any load-responsive protective relay applied at the terminal of the Element. A load-responsive protective relay that goes without evaluation may not be secure for a stable power swing and could in the planning time frame, under emergency, abnormal, or restorative conditions anticipated by the preparations, directly and adversely affect the electrical state or capability of the bulk electric system, or the ability to effectively monitor, control, or restore the bulk electric system. <del>However, violation of a medium risk requirement is unlikely, under emergency, abnormal, or restoration conditions anticipated by the preparations, to lead to bulk electric system instability, separation, or cascading failures, nor to hinder restoration to a normal condition.</del></p> <p>Identifying an Element that is expected to encounter stable power swings based on prescribed criteria is the first step in ensuring the reliable operation of the BES and in preventing the future severity of Disturbances from affecting a wider area. <del>However, violation of this requirement is unlikely to under emergency, abnormal, or restorative conditions anticipated by the preparations, directly cause or contribute to bulk electric system instability, separation, or a cascading sequence of failures, or could place the bulk electric system at an unacceptable risk of instability, separation, or cascading failures, or could hinder restoration to a normal condition.</del></p>
<p>FERC VRF G1 Discussion</p>	<p>Guideline 1- Consistency w/ Blackout Report:            The blackout report and subsequent technical analysis identified that two BPS transmission lines tripped due to protective relay operation in response to stable power swings. The protection system operations on these lines did not contribute significantly to the overall outcome of the August 14, 2003 system disturbance; however, protection system operation during stable powers swings could negatively impact system reliability under different operating conditions. Identifying Elements prone to power swings and the subsequent mitigation of load-responsive protective relays applied at the terminals of these Elements will reduce the likelihood of reoccurrence. This <del>requirement</del><u>Requirement</u> is consistent with the intent of Recommendation 8: Improve System Protection to Slow or Limit the Spread of Future Cascading Outages. While the actions associated with this recommendation did not focus specifically on this issue, the recommendation does note that “power system protection devices should be set to address the specific</p>

VRF and VSL Justifications – PRC-026-1, R1

	condition of concern, such as a fault, out-of-step condition, etc., and should not compromise a power system's inherent physical capability to slow down or stop a cascading event."
FERC VRF G2 Discussion	Guideline 2- Consistency within a Reliability Standard: The <del>requirement</del> <a href="#">Requirement</a> has a single reliability activity associated with the reliability objective and no sub-Requirement(s) which allows a single VRF to be assigned; therefore no conflict(s) exist.
FERC VRF G3 Discussion	Guideline 3- Consistency among Reliability Standards: The <del>requirement</del> <a href="#">Requirement</a> is consistent with <a href="#">NERC</a> Reliability Standards FAC-014-2, R6 ("...Planning Authority shall identify the subset of multiple contingencies...") which has a VRF of Medium.
FERC VRF G4 Discussion	Guideline 4- Consistency with NERC Definitions of VRFs: A failure to identify an Element meeting the criteria prohibits further evaluation of any load-responsive protective relay applied at the terminal of the Element. A load-responsive protective relay that goes without evaluation may not be secure for a stable power swing and could in the planning time frame, under emergency, abnormal, or restorative conditions anticipated by the preparations, directly and adversely affect the electrical state or capability of the bulk electric system, or the ability to effectively monitor, control, or restore the bulk electric system. <del>However, violation of a medium risk requirement is unlikely, under emergency, abnormal, or restoration conditions anticipated by the preparations, to lead to bulk electric system instability, separation, or cascading failures, nor to hinder restoration to a normal condition.</del> Identifying an Element that is expected to encounter stable power swings based on prescribed criteria is the first step in ensuring the reliable operation of the BES and in preventing the future severity of Disturbances from affecting a wider area. <del>However, violation of this requirement is unlikely to under emergency, abnormal, or restorative conditions anticipated by the preparations, directly cause or contribute to bulk electric system instability, separation, or a cascading sequence of failures, or could place the bulk electric system at an unacceptable risk of instability, separation, or cascading failures, or could hinder restoration to a normal condition.</del>
FERC VRF G5 Discussion	Guideline 5- Treatment of Requirements that Co-mingle More than One Obligation: This <del>requirement</del> <a href="#">Requirement</a> does not co-mingle reliability objectives of differing risk; therefore, the assigned VRF of Medium is consistent.

VRF and VSL Justifications – PRC-026-1, R1

Proposed VSL

Lower	Moderate	High	Severe
<p>The <del>responsible entity</del> <a href="#">Planning Coordinator</a> identified an Element and provided notification in accordance with Requirement R1, but was less than or equal to 30 calendar days late.</p>	<p>The <del>responsible entity</del> <a href="#">Planning Coordinator</a> identified an Element and provided notification in accordance with Requirement R1, but was more than 30 calendar days and less than or equal to 60 calendar days late.</p>	<p>The <del>responsible entity</del> <a href="#">Planning Coordinator</a> identified an Element and provided notification in accordance with Requirement R1, but was more than 60 calendar days and less than or equal to 90 calendar days late.</p>	<p>The <del>responsible entity</del> <a href="#">Planning Coordinator</a> identified an Element and provided notification in accordance with Requirement R1, but was more than 90 calendar days late.</p> <p>OR</p> <p>The <del>responsible entity</del> <a href="#">Planning Coordinator</a> failed to identify an Element <del>or</del> <a href="#">in accordance with Requirement R1.</a></p> <p>OR</p> <p><a href="#">The Planning Coordinator failed</a> to provide notification in accordance with Requirement R1.</p>

<p>NERC VSL Guidelines</p>	<p>Meets NERC’s VSL Guidelines—There is an incremental aspect to the VSL for tardiness and a binary aspect for failure. The VSL is entity size-neutral because performance is Element-driven and not by the total assets which an entity may have awareness over.</p>		
<p>FERC VSL G1 Violation Severity Level Assignments Should Not Have the Unintended Consequence of Lowering the Current Level</p>	<p>The proposed VSL does not lower the current level of compliance because the <del>requirement</del> <a href="#">Requirement</a> is new.</p>		



VRF and VSL Justifications – PRC-026-1, R1

<p>of Compliance</p>	
<p>FERC VSL G2 Violation Severity Level Assignments Should Ensure Uniformity and Consistency in the Determination of Penalties Guideline 2a: The Single Violation Severity Level Assignment Category for "Binary" Requirements Is Not Consistent Guideline 2b: Violation Severity Level Assignments that Contain Ambiguous Language</p>	<p>Guideline 2a: This <del>requirement</del><a href="#">Requirement</a> is not binary; therefore, this criterion does not apply.</p> <p>Guideline 2b: The proposed VSL does not use any ambiguous terminology, thereby supporting uniformity and consistency in the determination of similar penalties for similar violations.</p>
<p>FERC VSL G3 Violation Severity Level Assignment Should Be Consistent with the Corresponding Requirement</p>	<p>The proposed VSL uses similar terminology to that used in the corresponding <del>requirement</del><a href="#">Requirement</a>, and is therefore consistent with the <del>requirement</del><a href="#">Requirement</a>.</p>
<p>FERC VSL G4 Violation Severity Level Assignment Should Be Based on A Single Violation, Not on A Cumulative Number of Violations</p>	<p>The VSL is based on a single violation and not cumulative violations.</p>

VRF and VSL Justifications – PRC-026-1, R2 and R3

Proposed VRF	Medium
<p>NERC VRF Discussion</p>	<p>A Violation Risk Factor of Medium is consistent with the NERC VRF Guidelines: A failure to identify an Element meeting the criteria prohibits further evaluation of any load-responsive protective relay applied at the terminal of the Element. A load-responsive protective relay that goes without evaluation may not be secure for a stable power swing and could in the planning time frame, under emergency, abnormal, or restorative conditions anticipated by the preparations, directly and adversely affect the electrical state or capability of the bulk electric system, or the ability to effectively monitor, control, or restore the bulk electric system. <del>However, violation of a medium risk requirement is unlikely, under emergency, abnormal, or restoration conditions anticipated by the preparations, to lead to bulk electric system instability, separation, or cascading failures, nor to hinder restoration to a normal condition.</del></p> <p>Identifying an Element that is expected to encounter stable power swings based on prescribed criteria is the first step in ensuring the reliable operation of the BES and in preventing the future severity of Disturbances from affecting a wider area. <del>However, violation of this requirement is unlikely to under emergency, abnormal, or restorative conditions anticipated by the preparations, directly cause or contribute to bulk electric system instability, separation, or a cascading sequence of failures, or could place the bulk electric system at an unacceptable risk of instability, separation, or cascading failures, or could hinder restoration to a normal condition.</del></p>
<p>FERC VRF G1 Discussion</p>	<p>Guideline 1- Consistency w/ Blackout Report:                      The blackout report and subsequent technical analysis identified that two BPS transmission lines tripped due to protective relay operation in response to stable power swings. The protection system operations on these lines did not contribute significantly to the overall outcome of the August 14, 2003 system disturbance; however, protection system operation during stable powers swings could negatively impact system reliability under different operating conditions. Identifying Elements prone to power swings and the subsequent mitigation of load-responsive protective relays applied at the terminals of these Elements will reduce the likelihood of reoccurrence. This <del>requirement</del><u>Requirement</u> is consistent with the intent of Recommendation 8: Improve System Protection to Slow or Limit the Spread of Future Cascading Outages. While the actions associated with this recommendation did not focus specifically on this issue, the recommendation does note that “power system protection devices should be set to address the specific</p>

VRF and VSL Justifications – PRC-026-1, R2 and R3	
	condition of concern, such as a fault, out-of-step condition, etc., and should not compromise a power system's inherent physical capability to slow down or stop a cascading event."
FERC VRF G2 Discussion	Guideline 2- Consistency within a Reliability Standard: The <del>requirement</del> <u>Requirement</u> has a single reliability activity associated with the reliability objective and no sub-Requirement(s) which allows a single VRF to be assigned; therefore no conflict(s) exist.
FERC VRF G3 Discussion	Guideline 3- Consistency among Reliability Standards: <del>The requirement is consistent with Reliability Standards FAC-014-2, R6 ("...Planning Authority shall identify the subset of multiple contingencies...") which has a VRF of Medium.</del>
FERC VRF G4 Discussion	Guideline 4- Consistency with NERC Definitions of VRFs: A failure to identify an Element meeting the criteria prohibits further evaluation of any load-responsive protective relay applied at the terminal of the Element. A load-responsive protective relay that goes without evaluation may not be secure for a stable power swing and could in the planning time frame, under emergency, abnormal, or restorative conditions anticipated by the preparations, directly and adversely affect the electrical state or capability of the bulk electric system, or the ability to effectively monitor, control, or restore the bulk electric system. <del>However, violation of a medium risk requirement is unlikely, under emergency, abnormal, or restoration conditions anticipated by the preparations, to lead to bulk electric system instability, separation, or cascading failures, nor to hinder restoration to a normal condition.</del> Identifying an Element that is expected to encounter stable power swings based on prescribed criteria is the first step in ensuring the reliable operation of the BES and in preventing the future severity of Disturbances from affecting a wider area. <del>However, violation of this requirement is unlikely to under emergency, abnormal, or restorative conditions anticipated by the preparations, directly cause or contribute to bulk electric system instability, separation, or a cascading sequence of failures, or could place the bulk electric system at an unacceptable risk of instability, separation, or cascading failures, or could hinder restoration to a normal condition.</del>
FERC VRF G5 Discussion	Guideline 5- Treatment of Requirements that Co-mingle More than One Obligation: This <del>requirement</del> <u>Requirement</u> does not co-mingle reliability objectives of differing risk; therefore, the assigned VRF of Medium is consistent.

VRF and VSL Justifications – PRC-026-1, R2 and R3

Proposed VSL

Lower	Moderate	High	Severe
<p>The <u>responsible entity</u> Transmission Owner identified <u>an Element</u> and <u>provided notification</u> in accordance with Requirement R2, but was less than or equal to <del>30</del><u>10</u> calendar days late.</p>	<p>The <u>responsible entity</u> Transmission Owner identified <u>an Element</u> and <u>provided notification</u> in accordance with Requirement R2, but was more than <del>30</del><u>10</u> calendar days and less than or equal to <del>60</del><u>20</u> calendar days late.</p>	<p>The <u>responsible entity</u> Transmission Owner identified <u>an Element</u> and <u>provided notification</u> in accordance with Requirement R2, but was more than <del>60</del><u>20</u> calendar days and less than or equal to <del>90</del><u>30</u> calendar days late.</p>	<p>The <u>responsible entity</u> Transmission Owner identified <u>an Element</u> and <u>provided notification</u> in accordance with Requirement R2, but was more than <del>90</del><u>30</u> calendar days late.</p> <p>OR</p> <p>The <u>responsible entity</u> Transmission Owner failed to identify an Element in accordance with Requirement R2.</p> <p><u>OR</u></p> <p><u>The Transmission Owner failed to provide notification in accordance with Requirement R2.</u></p>

<p>NERC VSL Guidelines</p>	<p>Meets NERC’s VSL Guidelines—There is an incremental aspect to the VSL for tardiness and a binary aspect for failure. The VSL is entity size-neutral because performance is Element-driven and not by the total assets which an entity may have awareness over.</p>
----------------------------	-----------------------------------------------------------------------------------------------------------------------------------------------------------------------------------------------------------------------------------------------------------------------

<p>FERC VSL G1 Violation Severity Level Assignments Should Not Have the Unintended Consequence</p>	<p>The proposed VSL does not lower the current level of compliance because the <del>requirement</del><u>Requirement</u> is new.</p>
----------------------------------------------------------------------------------------------------	-------------------------------------------------------------------------------------------------------------------------------------

VRF and VSL Justifications – PRC-026-1, R2 and R3

<p>of Lowering the Current Level of Compliance</p>	
<p>FERC VSL G2 Violation Severity Level Assignments Should Ensure Uniformity and Consistency in the Determination of Penalties Guideline 2a: The Single Violation Severity Level Assignment Category for "Binary" Requirements Is Not Consistent Guideline 2b: Violation Severity Level Assignments that Contain Ambiguous Language</p>	<p>Guideline 2a: This <del>requirement</del><a href="#">Requirement</a> is not binary; therefore, this criterion does not apply.</p> <p>Guideline 2b: The proposed VSL does not use any ambiguous terminology, thereby supporting uniformity and consistency in the determination of similar penalties for similar violations.</p>
<p>FERC VSL G3 Violation Severity Level Assignment Should Be Consistent with the Corresponding Requirement</p>	<p>The proposed VSL uses similar terminology to that used in the corresponding <del>requirement</del><a href="#">Requirement</a>, and is therefore consistent with the <del>requirement</del><a href="#">Requirement</a>.</p>
<p>FERC VSL G4 Violation Severity Level Assignment Should Be Based on A Single Violation, Not on A Cumulative Number of Violations</p>	<p>The VSL is based on a single violation and not cumulative violations.</p>

VRF and VSL Justifications – PRC-026-1, R3R4	
Proposed VRF	<u>MediumHigh</u>
NERC VRF Discussion	<p>A Violation Risk Factor of <u>MediumHigh</u> is consistent with the NERC VRF Guidelines: A failure to <del>ensure</del><u>evaluate that</u> the Protection System <del>will is expected to</del> not trip <del>in response to</del> for a stable power swing for an identified Element could <del>in the planning time frame</del>, under emergency, abnormal, or restorative conditions anticipated by the preparations, directly <del>and adversely affect the electrical state</del><u>cause</u> or <del>capability of the bulk electric system, or the ability to effectively monitor, control, or restore the bulk electric system. However, violation of a medium risk requirement is unlikely, under emergency, abnormal, or restoration conditions anticipated by the preparations, to lead</del><u>contribute</u> to bulk electric system instability, separation, or <u>a cascading sequence of failures, nor to</u> could place the bulk electric system at an unacceptable risk of instability, separation, or cascading failures, or could hinder restoration to a normal condition.</p> <p>If a Protection System is less secure during stable power swings, it increases the risk of tripping should the Protection System be challenged by a power swing; <del>However, violation of this requirement is unlikely to lead to bulk electric system instability, separation, or cascading failures.</del></p>
FERC VRF G1 Discussion	<p>Guideline 1- Consistency w/ Blackout Report:                      The blackout report and subsequent technical analysis identified that two BPS transmission lines tripped due to protective relay operation in response to stable power swings. The protection system operations on these lines did not contribute significantly to the overall outcome of the August 14, 2003 system disturbance; <del>however, protection system operation during stable powers swings could negatively impact system reliability under different operating conditions.</del> Identifying Elements prone to power swings and the subsequent mitigation of load-responsive protective relays applied at the terminals of these Elements will reduce the likelihood of reoccurrence. This <del>requirement</del><u>Requirement</u> is consistent with the intent of Recommendation 8: Improve System Protection to Slow or Limit the Spread of Future Cascading Outages. While the actions associated with this recommendation did not focus specifically on this issue, the recommendation does note that “power system protection devices should be set to address the specific condition of concern, such as a fault, out-of-step condition, etc., and should not compromise a power system’s inherent physical capability to slow down or stop a cascading event.”</p>
FERC VRF G2 Discussion	Guideline 2- Consistency within a Reliability Standard:

VRF and VSL Justifications – PRC-026-1, R3R1			
	The <del>requirement</del> <u>Requirement</u> has a single reliability activity associated with the reliability objective and no sub-Requirement(s) which allows a single VRF to be assigned; therefore no conflict(s) exist.		
FERC VRF G3 Discussion	Guideline 3- Consistency among Reliability Standards: <del>This requirement</del> <u>The Requirement</u> is consistent with NERC Reliability Standard <del>FAC-002-1</del> <u>PRC-023-3</u> , R1.3 (“... <u>Evidence that the parties involved in the assessment have coordinated “...Each Transmission Owner, Generator Owner, and cooperated on...”</u> ) <u>Distribution Provider shall evaluate relay loadability at 0.85 per unit voltage and a power factor angle of 30 degrees”</u> ) which has a VRF of <del>Medium</del> <u>High</u> .		
FERC VRF G4 Discussion	Guideline 4- Consistency with NERC Definitions of VRFs: A failure to ensure the Protection System will not trip in response to a stable power swing for an identified Element could <del>in the planning time frame</del> , under emergency, abnormal, or restorative conditions anticipated by the preparations, directly <del>and adversely affect the electrical state</del> <u>cause or capability of the bulk electric system, or the ability to effectively monitor, control, or restore the bulk electric system. However, violation of a medium risk requirement is unlikely, under emergency, abnormal, or restoration conditions anticipated by the preparations, to lead</u> <u>contribute</u> to bulk electric system instability, separation, or <u>a cascading sequence of failures, nor to or could place the bulk electric system at an unacceptable risk of instability, separation, or cascading failures, or could</u> hinder restoration to a normal condition. If a Protection System is less secure during stable power swings, it increases the risk of tripping should the Protection System be challenged by a power swing; <del>However, violation of this requirement is unlikely to lead to bulk electric system instability, separation, or cascading failures.</del>		
FERC VRF G5 Discussion	Guideline 5- Treatment of Requirements that Co-mingle More than One Obligation: This <del>requirement</del> <u>Requirement</u> does not co-mingle reliability objectives of differing risk; therefore, the assigned VRF of Medium is consistent.		
Proposed VSL			
Lower	Moderate	High	Severe
The <del>responsible entity performed one of the options</del> <u>Generator Owner</u>	The <del>responsible entity performed one of the options</del> <u>Generator Owner</u>	The <del>responsible entity performed one of the options</del> <u>Generator Owner identified an Element and</u>	The <del>responsible entity performed one of the options</del> <u>Generator Owner identified an Element and</u>

VRF and VSL Justifications – PRC-026-1, ~~R3R1~~

<p><u>identified an Element and provided notification</u> in accordance with Requirement R3, but was less than or equal to <del>3010</del> calendar days late.</p>	<p><u>identified an Element and provided notification</u> in accordance with Requirement R3, but was more than <del>3010</del> calendar days and less than or equal to <del>6020</del> calendar days late.</p>	<p><u>provided notification</u> in accordance with Requirement R3, but was more than <del>6020</del> calendar days and less than or equal to <del>9030</del> calendar days late.</p>	<p><u>provided notification</u> in accordance with Requirement R3, but was more than <del>9030</del> calendar days late.</p> <p>OR</p> <p>The <del>responsible entity</del><u>Generator Owner</u> failed to <del>perform one of the options</del><u>identify an Element</u> in accordance with Requirement R3.</p> <p>OR</p> <p><u>The Generator Owner failed to provide notification in accordance with Requirement R3.</u></p>
<p>NERC VSL Guidelines</p>	<p>Meets NERC’s VSL Guidelines—There is an incremental aspect to the VSL for tardiness and a binary aspect for failure. The VSL is entity size-neutral because performance is driven by exception. For example, each <u>identified</u> Element <del>that requires further review</del> must be <del>provided to the Transmission Planner for simulation to determine the apparent impedance characteristics</del><u>evaluated</u>.</p>		
<p>FERC VSL G1 Violation Severity Level Assignments Should Not Have the Unintended Consequence of Lowering the Current Level of Compliance</p>	<p>The proposed VSL does not lower the current level of compliance because the <del>requirement</del><u>Requirement</u> is new.</p>		
<p>FERC VSL G2 Violation Severity Level</p>	<p>Guideline 2a: This <del>requirement</del><u>Requirement</u> is not binary; therefore, this criterion does not apply.</p>		



VRF and VSL Justifications – PRC-026-1, [R3R1](#)

<p>Assignments Should Ensure Uniformity and Consistency in the Determination of Penalties          Guideline 2a: The Single Violation Severity Level Assignment Category for "Binary" Requirements Is Not Consistent          Guideline 2b: Violation Severity Level Assignments that Contain Ambiguous Language</p>	<p>Guideline 2b:          The proposed VSL does not use any ambiguous terminology, thereby supporting uniformity and consistency in the determination of similar penalties for similar violations.</p>
<p>FERC VSL G3 Violation Severity Level Assignment Should Be Consistent with the Corresponding Requirement</p>	<p>The proposed VSL uses similar terminology to that used in the corresponding <del>requirement</del><a href="#">Requirement</a>, and is therefore consistent with the <del>requirement</del><a href="#">Requirement</a>.</p>
<p>FERC VSL G4 Violation Severity Level Assignment Should Be Based on A Single Violation, Not on A Cumulative Number of Violations</p>	<p>The VSL is based on a single violation and not cumulative violations.</p>

VRF and VSL Justifications – PRC-026-1, R4004-3, R5

Proposed VRF	Medium
NERC VRF Discussion	<p>A Violation Risk Factor of Medium is consistent with the NERC VRF Guidelines: <del>A failure</del><u>Failure</u> to <del>implement the</del><u>develop a</u> Corrective Action Plan <del>for</del><u>to modify</u> a Protection System of an identified Element <u>that does not meet the criteria</u> could in the planning time frame, under emergency, abnormal, or restorative conditions anticipated by the preparations, directly and adversely affect the electrical state or capability of the bulk electric system, or the ability to effectively monitor, control, or restore the bulk electric system. <del>However, violation of a medium risk requirement is unlikely, under emergency, abnormal, or restoration conditions anticipated by the preparations, to lead to bulk electric system instability, separation, or cascading failures, nor to hinder restoration to a normal condition.</del> An unmitigated Protection System could <del>contribute to affect</del> <u>the severity</u><del>electrical state or capability of future disturbances affecting a wider area, or potential equipment damage. However, violation of this requirement is unlikely to lead to</del> <u>the</u> bulk electric system <del>instability, separation, or cascading failures</del><u>the ability to effectively monitor, control, or restore the bulk electric system.</u></p>
FERC VRF G1 Discussion	<p>Guideline 1- Consistency w/ Blackout Report:            The blackout report and subsequent technical analysis identified that two BPS transmission lines tripped due to protective relay operation in response to stable power swings. The protection system operations on these lines did not contribute significantly to the overall outcome of the August 14, 2003 system disturbance; however, protection system operation during stable powers swings could negatively impact system reliability under different operating conditions. Identifying Elements prone to power swings and the subsequent mitigation of load-responsive protective relays applied at the terminals of these Elements will reduce the likelihood of reoccurrence. This <del>requirement</del><u>Requirement</u> is consistent with the intent of Recommendation 8: Improve System Protection to Slow or Limit the Spread of Future Cascading Outages. While the actions associated with this recommendation did not focus specifically on this issue, the recommendation does note that “power system protection devices should be set to address the specific condition of concern, such as a fault, out-of-step condition, etc., and should not compromise a power system’s inherent physical capability to slow down or stop a cascading event.”</p>

VRF and VSL Justifications – PRC-026-1, R-004-3, R5	
FERC VRF G2 Discussion	<p>Guideline 2- Consistency within a Reliability Standard:  <a href="#">The requirement This Requirement</a> has a single reliability activity associated with the reliability objective and no sub-Requirement(s) which allows a single VRF to be assigned; therefore no conflict(s) exist.</p>
FERC VRF G3 Discussion	<p>Guideline 3- Consistency among Reliability Standards:  <a href="#">The requirement This Requirement</a> is consistent with <a href="#">the following</a> Reliability Standards <a href="#">which requiring corrective actions or Corrective Action Plans</a>; PRC-016-0.1, R2 (“...shall take corrective actions to avoid future Misoperations”), PRC-022-1, R1.5 (“For any Misoperation, a Corrective Action Plan...”), <a href="#">and</a> FAC-003, R5 (“...Transmission Owner or applicable Generator Owner shall take corrective action to ensure continued vegetation management”) all <a href="#">three</a> of which have a VRF of Medium.</p>
FERC VRF G4 Discussion	<p><a href="#">Guideline 4- Consistency with NERC Definitions of VRFs:</a>            A Violation Risk Factor of Medium is consistent with the NERC VRF Guidelines:            A failure to implement the Corrective Action Plan for a Protection System of an identified Element could in the planning time frame, under emergency, abnormal, or restorative conditions anticipated by the preparations, directly and adversely affect the electrical state or capability of the bulk electric system, or the ability to effectively monitor, control, or restore the bulk electric system. <del>However, violation of a medium risk requirement is unlikely, under emergency, abnormal, or restoration conditions anticipated by the preparations, to lead to bulk electric system instability, separation, or cascading failures, nor to hinder restoration to a normal condition.</del>            An unmitigated Protection System could contribute to the severity of future disturbances affecting a wider area, or potential equipment damage. <del>However, violation of this requirement is unlikely to lead to bulk electric system instability, separation, or cascading failures.</del></p>
FERC VRF G5 Discussion	<p>Guideline 5- Treatment of Requirements that Co-mingle More than One Obligation:            This requirement does not co-mingle reliability objectives of differing risk; therefore, the assigned VRF of Medium is consistent.</p>

VRF and VSL Justifications – PRC-026-1, R4004-3, R5

Proposed VSL			
Lower	Moderate	High	Severe
<p><u>The Generator Owner or Transmission Owner developed a CAP in accordance with Requirement R5, but in more than 60 calendar days and less than or equal to 70 calendar days.</u></p>	<p><u>The Generator Owner or Transmission Owner developed a CAP in accordance with Requirement R5, but in more than 70 calendar days and less than or equal to 80 calendar days.</u></p>	<p><u>The Generator Owner or Transmission Owner developed a CAP in accordance with Requirement R5, but in more than 80 calendar days and less than or equal to 90 calendar days.</u></p>	<p><u>The Generator Owner or Transmission Owner developed a CAP in accordance with Requirement R5, but in more than 90 calendar days.</u></p> <p><u>OR</u></p> <p><u>The Generator Owner or Transmission Owner failed to develop a CAP in accordance with Requirement R5.</u></p>
<p><u>NERC VSL Guidelines</u></p>	<p><u>Meets NERC’s VSL Guidelines—There is an incremental aspect to the VSL for failing to develop the Corrective Action Plan in a timely fashion and a binary aspect for a complete failure. The VSL is entity size-neutral because performance is driven by the need to mitigate the Protection System so that it is expected to not trip on a stable power swing.</u></p>		
<p><u>FERC VSL G1</u></p> <p><u>Violation Severity Level Assignments Should Not Have the Unintended Consequence of Lowering the Current Level</u></p>	<p><u>The proposed VSL does not lower the current level of compliance because the Requirement is new.</u></p>		

VRF and VSL Justifications – PRC-026-1, R4004-3, R5

<p><u>of Compliance</u></p>	
<p><u>FERC VSL G2</u>  <u>Violation Severity Level</u>  <u>Assignments Should Ensure</u>  <u>Uniformity and Consistency in</u>  <u>the Determination of Penalties</u></p> <p><u>Guideline 2a: The Single</u>  <u>Violation Severity Level</u>  <u>Assignment Category for</u>  <u>"Binary" Requirements Is Not</u>  <u>Consistent</u></p> <p><u>Guideline 2b: Violation Severity</u>  <u>Level Assignments that Contain</u>  <u>Ambiguous Language</u></p>	<p><u>Guideline 2a:</u>  <u>This Requirement is not binary; therefore, this criterion does not apply.</u></p> <p><u>Guideline 2b:</u>  <u>This proposed VSL does not use any ambiguous terminology, thereby supporting uniformity and</u>  <u>consistency in the determination of similar penalties for similar violations.</u></p>
<p><u>FERC VSL G3</u>  <u>Violation Severity Level</u>  <u>Assignment Should Be</u>  <u>Consistent with the</u>  <u>Corresponding Requirement</u></p>	<p><u>This proposed VSL uses similar terminology to that used in the corresponding Requirement, and is</u>  <u>therefore consistent with this Requirement.</u></p>
<p><u>FERC VSL G4</u>  <u>Violation Severity Level</u>  <u>Assignment Should Be Based on</u></p>	<p><u>The VSL is based on a single violation and not cumulative violations.</u></p>

VRF and VSL Justifications – PRC-026-1, R4004-3, R5

A Single Violation, Not on A Cumulative Number of Violations

VRF and VSL Justifications – PRC-026-1, R6

Proposed VRF

Medium

NERC VRF Discussion

A Violation Risk Factor of Medium is consistent with the NERC VRF Guidelines:  
A failure to implement the Corrective Action Plan for modifying a Protection System of an identified Element could in the planning time frame, under emergency, abnormal, or restorative conditions anticipated by the preparations, directly and adversely affect the electrical state or capability of the bulk electric system, or the ability to effectively monitor, control, or restore the bulk electric system.  
An unmitigated Protection System could affect the electrical state or capability of the bulk electric system, or the ability to effectively monitor, control, or restore the bulk electric system.

FERC VRF G1 Discussion

Guideline 1- Consistency w/ Blackout Report:  
The blackout report and subsequent technical analysis identified that two BPS transmission lines tripped due to protective relay operation in response to stable power swings. The protection system operations on these lines did not contribute significantly to the overall outcome of the August 14, 2003 system disturbance; however, protection system operation during stable powers swings could negatively impact system reliability under different operating conditions. Identifying Elements prone to power swings and the subsequent mitigation of load-responsive protective relays applied at the terminals of these Elements will reduce the likelihood of reoccurrence. This Requirement is consistent with the intent of Recommendation 8: Improve System Protection to Slow or Limit the Spread of Future Cascading Outages. While the actions associated with this recommendation did not focus specifically on this issue, the

<u>VRF and VSL Justifications – PRC-026-1, R6</u>			
	<p><u>recommendation does note that “power system protection devices should be set to address the specific condition of concern, such as a fault, out-of-step condition, etc., and should not compromise a power system’s inherent physical capability to slow down or stop a cascading event.”</u></p>		
<u>FERC VRF G2 Discussion</u>	<p><u>Guideline 2- Consistency within a Reliability Standard:</u>  <u>The Requirement has a single reliability activity associated with the reliability objective and no sub-Requirement(s) which allows a single VRF to be assigned; therefore no conflict(s) exist.</u></p>		
<u>FERC VRF G3 Discussion</u>	<p><u>Guideline 3- Consistency among Reliability Standards:</u>  <u>This Requirement is consistent with the following Reliability Standards which requiring corrective actions or Corrective Action Plans: PRC-016-0.1, R2 (“...shall take corrective actions to avoid future Misoperations”), PRC-022-1, R1.5 (“For any Misoperation, a Corrective Action Plan...”), and FAC-003, R5 (“...Transmission Owner or applicable Generator Owner shall take corrective action to ensure continued vegetation management”) all of which have a VRF of Medium.</u></p>		
<u>FERC VRF G4 Discussion</u>	<p><u>A Violation Risk Factor of Medium is consistent with the NERC VRF Guidelines:</u>  <u>A failure to implement the Corrective Action Plan for a Protection System of an identified Element could in the planning time frame, under emergency, abnormal, or restorative conditions anticipated by the preparations, directly and adversely affect the electrical state or capability of the bulk electric system, or the ability to effectively monitor, control, or restore the bulk electric system.</u>  <u>An unmitigated Protection System could contribute to the severity of future disturbances affecting a wider area, or potential equipment damage.</u></p>		
<u>FERC VRF G5 Discussion</u>	<p><u>Guideline 5- Treatment of Requirements that Co-mingle More than One Obligation:</u>  <u>This Requirement does not co-mingle reliability objectives of differing risk; therefore, the assigned VRF of Medium is consistent.</u></p>		
<u>Proposed VSL</u>			
<u>Lower</u>	<u>Moderate</u>	<u>High</u>	<u>Severe</u>
The responsible entity implemented, but failed to update a CAP, when actions or	N/A	N/A	The responsible entity failed to implement a CAP in accordance with Requirement R4.

VRF and VSL Justifications – PRC-026-1, R6

<p>timetables changed, in accordance with Requirement R4.</p>			
<p>NERC VSL Guidelines</p>	<p>Meets NERC’s VSL Guidelines—There is an incremental aspect to the VSL for <del>tardiness</del><u>failing to update the Corrective Action Plan</u> and a binary aspect for failure-<u>to implement</u>. The VSL is entity size-neutral because performance is driven by <del>exception. For example, each Element</del><u>the need to mitigate the Protection System so that requires further review must be provided to the Transmission Planner for simulation to determine the apparent impedance characteristics</u>it is expected to not trip on a stable power swing.</p>		
<p>FERC VSL G1 Violation Severity Level Assignments Should Not Have the Unintended Consequence of Lowering the Current Level of Compliance</p>	<p>The proposed VSL does not lower the current level of compliance because the <del>requirement</del><u>Requirement</u> is new.</p>		
<p>FERC VSL G2 Violation Severity Level Assignments Should Ensure Uniformity and Consistency in the Determination of Penalties Guideline 2a: The Single Violation Severity Level Assignment Category for "Binary" Requirements Is Not Consistent Guideline 2b: Violation Severity Level Assignments that Contain Ambiguous Language</p>	<p>Guideline 2a: This <del>requirement</del><u>Requirement</u> is not binary; therefore, this criterion does not apply.</p> <p>Guideline 2b: The proposed VSL does not use any ambiguous terminology, thereby supporting uniformity and consistency in the determination of similar penalties for similar violations.</p>		



VRF and VSL Justifications – PRC-026-1, R6

FERC VSL G3 Violation Severity Level Assignment Should Be Consistent with the Corresponding Requirement	The proposed VSL uses similar terminology to that used in the corresponding <del>requirement</del> <u>Requirement</u> , and is therefore consistent with the <del>requirement</del> <u>Requirement</u> .
FERC VSL G4 Violation Severity Level Assignment Should Be Based on A Single Violation, Not on A Cumulative Number of Violations	The VSL is based on a single violation and not cumulative violations.

## Table of Issues and Directives

### Project 2010-13.3 – Relay Loadability: Stable Power Swings

Table of Issues and Directives Associated with PRC-026-1

Source	Issue or Directive Language (including Para. #)	Section and/or Requirement(s)	Consideration of Issue or Directive
FERC Order 733	150. We will not direct the ERO to modify PRC-023-1 to address stable power swings. However, because both NERC and the Task Force have identified undesirable relay operation due to stable power swings as a reliability issue, we direct the ERO to develop a Reliability Standard that requires the use of protective relay systems that can differentiate between faults and stable power swings and, when necessary, phases out protective relay systems that cannot meet this	All requirements	<p>The PRC-026-1 standard is responsive to this directive because it applies a focused approach for the Planning Coordinator to identify BES Elements according to the Requirement R1, Criteria. The criterion used to identify a BES Element is based on the NERC System Protection and Control Subcommittee technical document, <i>Protection System Response to Power Swings</i> ("PSRPS Report").<sup>1</sup> Specific criterion is based on where power swings are most likely.</p> <p>These include (1) Generator(s) where an angular stability constraint exists which is addressed by an operating limit or a Remedial Action Scheme (RAS)</p>

<sup>1</sup> NERC System Protection and Control Subcommittee technical document, *Protection System Response to Power Swings*, August 2013: [http://www.nerc.com/comm/PC/System%20Protection%20and%20Control%20Subcommittee%20SPCS%2020/SPCS%20Power%20Swing%20Report\\_Final\\_20131015.pdf](http://www.nerc.com/comm/PC/System%20Protection%20and%20Control%20Subcommittee%20SPCS%2020/SPCS%20Power%20Swing%20Report_Final_20131015.pdf)

Table of Issues and Directives Associated with PRC-026-1

Source	Issue or Directive Language (including Para. #)	Section and/or Requirement(s)	Consideration of Issue or Directive
	<p>requirement.</p> <p>We also direct the ERO to file a report no later than 120 days of this Final Rule addressing the issue of protective relay operation due to power swings. The report should include an action plan and timeline that explains how and when the ERO intends to address this issue through its Reliability Standards development process.</p> <p>AND</p> <p>153. While we recognize that addressing stable power swings is a complex issue, we note that more than six years have passed since the August 2003 blackout and there is still no Reliability Standard that addresses relays tripping due to stable power swings. Additionally, NERC has long identified undesirable relay operation due to stable power swings as a</p>		<p>and those Elements terminating at the transmission switching station associated with the generator(s); (2) An Element that is monitored as part of a System Operating Limit (SOL) that has been established based on angular stability constraints identified in system planning or operating studies; (3) An Element that forms the boundary of an island due to angular instability within the most recent underfrequency load shedding (UFLS) assessment; (4) An Element identified in the most recent Planning Assessment where relay tripping occurs due to a stable or unstable power swing during a simulated disturbance; and (5) An Element reported by the Generator Owner or Transmission Owner, until the Planning Coordinator determines the Element is no longer susceptible to power swings.</p> <p>Requirement R2 is responsive to the directive by requiring the Transmission Owner to identify any BES Elements that trip due to a stable or unstable power swing during an actual system Disturbance and any Element that forms the boundary of an island during an actual system Disturbance due to the</p>

Table of Issues and Directives Associated with PRC-026-1

Source	Issue or Directive Language (including Para. #)	Section and/or Requirement(s)	Consideration of Issue or Directive
	<p>reliability issue. Consequently, pursuant to section 215(d)(5) of the FPA, we find that undesirable relay operation due to stable power swings is a specific matter that the ERO must address to carry out the goals of section 215, and we direct the ERO to develop a Reliability Standard addressing undesirable relay operation due to stable power swings.</p>		<p>operation of its load-responsive protective relays. This insures that any Elements that trip due to actual system Disturbances are identified, reported to the Planning Coordinator for awareness, and evaluated using PRC-026-1 – Attachment B, Criteria A and B.</p> <p>Requirement R3 is responsive to the directive by requiring the Generator Owner to identify any BES Elements that trip due to a stable or unstable power swing during an actual system Disturbance and due to the operation of its load-responsive protective relays. This insures that any Elements that trip due to actual system Disturbances are identified, reported to the Planning Coordinator for awareness, and evaluated using PRC-026-1 – Attachment B, Criteria A and B.</p> <p>Requirement R5 requires Generator Owners and Transmission Owners to evaluate its load-responsive protective relays that are applied at all of the terminals of each Element identified by Requirements R1, R2, and R3. The evaluation initially and periodically according to the Requirement, ensures that either the load-responsive protective</p>

Table of Issues and Directives Associated with PRC-026-1

Source	Issue or Directive Language (including Para. #)	Section and/or Requirement(s)	Consideration of Issue or Directive
			<p>relay meets the PRC-026-1 – Attachment B, Criteria A and B, or that when it is found not to meet the criteria that the entity develop a Corrective Action Plan (CAP) in Requirement R5.</p> <p>Requirement R5 ensures a CAP is developed to modify the Protection System or apply power swing blocking so that the Protection System is not expected to trip in response to a stable power swing.</p> <p>Requirement R6 requires the entity to implement each developed CAP to modify its Protection System to achieve the PRC-026-1 – Attachment B, Criteria A and B.</p>
	<p>162. The PSEG Companies also assert that the Commission’s approach to stable power swings should be inclusive and include “islanding” strategies in conjunction with out-of-step blocking or tripping requirements. We agree with the PSEG Companies and direct the ERO to consider “islanding” strategies that achieve the fundamental</p>	<p>Requirement R1, Criterion 3 and Requirement R2, Criterion 2.</p>	<p>Islanding strategies were considered during the development of the proposed standard. It was determined that consideration of islanding strategies does not comport with the purpose and approach of the proposed standard. The proposed standard’s purpose is to ensure that load-responsive protective relays are expected to not trip in response to stable power swings during non-Fault conditions, not to determine where the transmission system Elements</p>

Table of Issues and Directives Associated with PRC-026-1

Source	Issue or Directive Language (including Para. #)	Section and/or Requirement(s)	Consideration of Issue or Directive
	performance for all islands in developing the new Reliability Standard addressing stable power swings.		<p>should form island boundaries.</p> <p>With respect to considering the islanding concern, the proposed standard does require that an Element that was part of a boundary that formed an island since January 1, 2003 be identified as an that is within the scope of the proposed standard.</p> <p>Any identified Element(s) require the Generator Owner and Transmission Owner entities to determine whether its load-responsive protective relays applied at the terminal of such an Element, if any, are susceptible to tripping in response to a stable power swing. If so, the Generator Owner and Transmission Owner is required to take specific action according to the requirements to reduce the risk that its load-responsive protective relays would trip in response to stable power swings during non-Fault conditions.</p>

# Standards Announcement **Reminder**

## Project 2010-13.3 Phase 3 of Relay Loadability: Stable Power Swings

### PRC-026-1

Additional Ballot Now Open through October 6, 2014

#### [Now Available](#)

An additional ballot for **PRC-026-1 – Relay Performance During Stable Power Swings** and non-binding poll of the associated Violation Risk Factors (VRFs) and Violation Severity Levels (VSLs) are open through **8 p.m. Eastern on Monday, October 6, 2014**.

#### **Instructions for Balloting**

Members of the ballot pools associated with this project may log in and submit their vote for the standard and associated VRFs and VSLs by clicking [here](#).

**Note:** If a member cast a vote in the initial ballot, that vote will not carry over to the additional ballot. It is the responsibility of the registered voter in the ballot pool to cast a vote again in the additional ballot. To ensure a quorum is reached, if you do not want to vote affirmative or negative, please cast an abstention.

#### **Next Steps**

The ballot results will be announced and posted on the project page. The drafting team will consider all comments received during the formal comment period and, if needed, make revisions to the standard and post it for an additional ballot. If the comments do not show the need for significant revisions, the standard will proceed to a final ballot.

For information on the **Standards Development Process**, please refer to the [Standard Processes Manual](#).

*For more information or assistance, please contact [Scott Barfield-McGinnis](#)  
Standards Developer, or at 404-446-9689.*

North American Electric Reliability Corporation  
3353 Peachtree Rd, NE

Suite 600, North Tower  
Atlanta, GA 30326  
404-446-2560 | [www.nerc.com](http://www.nerc.com)



## Standards Announcement

### Project 2010-13.3 Phase 3 of Relay Loadability: Stable Power Swings

#### PRC-026-1

Formal Comment Period Now Open through October 6, 2014

#### [Now Available](#)

A 45-day formal comment period for **PRC-026-1 – Relay Performance During Stable Power Swings** is open through **8 p.m. Eastern on Monday, October 6, 2014.**

#### Instructions for Commenting

Please use the [electronic form](#) to submit comments on the standard. If you experience any difficulties in using the electronic form, please contact [Arielle Cunningham](#). An off-line, unofficial copy of the comment form is posted on the [project page](#).

#### Next Steps

An additional ballot and non-binding poll of the associated Violation Risk Factor and Violation Severity Levels will be conducted **September 26 through October 6, 2014.**

For information on the **Standards Development Process**, please refer to the [Standard Processes Manual](#).

*For more information or assistance, please contact [Scott Barfield-McGinnis](#)  
Standards Developer, or at 404-446-9689.*

North American Electric Reliability Corporation

3353 Peachtree Rd, NE

Suite 600, North Tower

Atlanta, GA 30326

404-446-2560 | [www.nerc.com](http://www.nerc.com)

# Standards Announcement

## Project 2010-13.3 Phase 3 of Relay Loadability: Stable Power Swings

### PRC-026-1

Formal Comment Period Now Open through October 6, 2014

#### [Now Available](#)

A 45-day formal comment period for **PRC-026-1 – Relay Performance During Stable Power Swings** is open through **8 p.m. Eastern on Monday, October 6, 2014.**

#### Instructions for Commenting

Please use the [electronic form](#) to submit comments on the standard. If you experience any difficulties in using the electronic form, please contact [Arielle Cunningham](#). An off-line, unofficial copy of the comment form is posted on the [project page](#).

#### Next Steps

An additional ballot and non-binding poll of the associated Violation Risk Factor and Violation Severity Levels will be conducted **September 26 through October 6, 2014.**

For information on the **Standards Development Process**, please refer to the [Standard Processes Manual](#).

*For more information or assistance, please contact [Scott Barfield-McGinnis](#)  
Standards Developer, or at 404-446-9689.*

North American Electric Reliability Corporation

3353 Peachtree Rd, NE

Suite 600, North Tower

Atlanta, GA 30326

404-446-2560 | [www.nerc.com](http://www.nerc.com)

# Standards Announcement

## Project 2010-13.3 Phase 3 of Relay Loadability: Stable Power Swings PRC-026-1

### Additional Ballot and Non-Binding Poll Results

#### [Now Available](#)

An additional ballot for **PRC-026-1 – Relay Performance During Stable Power Swings** and a non-binding poll of the associated Violation Risk Factors and Violation Severity Levels concluded at **8 p.m. Eastern on Monday, October 6, 2014**.

The standard achieved a quorum but did not receive sufficient affirmative votes for approval. Voting statistics are listed below, and the [Ballot Results](#) page provides a link to the detailed results for the ballot.

Ballot	Non-Binding Poll
Quorum /Approval	Quorum/Supportive Opinions
79.01% / 53.02%	77.71% / 51.71%

Background information for this project can be found on the [project page](#).

#### Next Steps

The drafting team will consider all comments received during the formal comment period to determine the next steps.

For more information on the **Standards Development Process**, please refer to the [Standard Processes Manual](#).

*For more information or assistance, please contact [Scott Barfield](#).*

North American Electric Reliability Corporation  
3353 Peachtree Rd, NE  
Suite 600, North Tower  
Atlanta, GA 30326  
404-446-2560 | [www.nerc.com](http://www.nerc.com)

Log In

- Ballot Pools
- Current Ballots
- Ballot Results
- Registered Ballot Body
- Proxy Voters
- Register

[Home Page](#)

Ballot Results	
<b>Ballot Name:</b>	Project 2010-13.3 Relay Loadability Stable Power Swings PRC-026- 1
<b>Ballot Period:</b>	9/26/2014 - 10/6/2014
<b>Ballot Type:</b>	Additional
<b>Total # Votes:</b>	286
<b>Total Ballot Pool:</b>	362
<b>Quorum:</b>	<b>79.01 % The Quorum has been reached</b>
<b>Weighted Segment Vote:</b>	53.02 %
<b>Ballot Results:</b>	<b>The Ballot has Closed</b>

Summary of Ballot Results										
Segment	Ballot Pool	Segment Weight	Affirmative		Negative		Negative Vote without a Comment	Abstain	No Vote	
			# Votes	Fraction	# Votes	Fraction				
1 - Segment 1	104	1	32	0.478	35	0.522	0	6	31	
2 - Segment 2	9	0.7	2	0.2	5	0.5	0	0	2	
3 - Segment 3	76	1	25	0.41	36	0.59	0	3	12	
4 - Segment 4	25	1	8	0.471	9	0.529	0	3	5	
5 - Segment 5	79	1	23	0.397	35	0.603	0	5	16	
6 - Segment 6	52	1	20	0.455	24	0.545	0	1	7	
7 - Segment 7	2	0	0	0	0	0	0	0	2	
8 - Segment 8	4	0.4	4	0.4	0	0	0	0	0	
9 - Segment	2	0.1	1	0.1	0	0	0	0	1	

9										
10 - Segment 10	9	0.8	8	0.8	0	0	0	1	0	
<b>Totals</b>	<b>362</b>	<b>7</b>	<b>123</b>	<b>3.711</b>	<b>144</b>	<b>3.289</b>	<b>0</b>	<b>19</b>	<b>76</b>	

Individual Ballot Pool Results				
Segment	Organization	Member	Ballot	NERC Notes
1	Ameren Services	Eric Scott	Negative	SUPPORTS THIRD PARTY COMMENTS - (Ameren)
1	American Electric Power	Paul B Johnson	Affirmative	
1	American Transmission Company, LLC	Andrew Z Pusztai	Affirmative	
1	Arizona Public Service Co.	Robert Smith		
1	Associated Electric Cooperative, Inc.	John Bussman	Negative	SUPPORTS THIRD PARTY COMMENTS - (AECI)
1	ATCO Electric	Glen Sutton	Negative	SUPPORTS THIRD PARTY COMMENTS - (PSEG)
1	Austin Energy	James Armke	Negative	SUPPORTS THIRD PARTY COMMENTS - (Luminant Generation Company, LLC)
1	Avista Utilities	Heather Rosentrater		
1	Balancing Authority of Northern California	Kevin Smith	Affirmative	
1	Baltimore Gas & Electric Company	Christopher J Scanlon	Affirmative	
1	BC Hydro and Power Authority	Patricia Robertson	Negative	SUPPORTS THIRD PARTY COMMENTS - (Public Service Enterprise Group)
1	Black Hills Corp	Wes Wingen	Abstain	
1	Brazos Electric Power Cooperative, Inc.	Tony Kroskey		
1	Bryan Texas Utilities	John C Fontenot	Affirmative	
1	CenterPoint Energy Houston Electric, LLC	John Brockhan	Negative	COMMENT RECEIVED
1	Central Electric Power Cooperative	Michael B Bax	Negative	SUPPORTS THIRD PARTY COMMENTS - (AECI)
1	Central Iowa Power Cooperative	Kevin J Lyons	Affirmative	
1	City of Tacoma, Department of Public Utilities, Light Division, dba Tacoma Power	Chang G Choi	Affirmative	
1	City of Tallahassee	Daniel S Langston	Negative	SUPPORTS THIRD PARTY COMMENTS - (PSEG)
1	Clark Public Utilities	Jack Stamper	Negative	SUPPORTS THIRD PARTY COMMENTS - (PSEG)
1	Colorado Springs Utilities	Shawna Speer		
1	Consolidated Edison Co. of New York	Christopher L de Graffenried	Affirmative	
1	CPS Energy	Glenn Pressler	Negative	COMMENT RECEIVED
1	Dairyland Power Coop.	Robert W. Roddy		
1	Deseret Power	James Tucker	Negative	SUPPORTS THIRD PARTY COMMENTS - (PSEG)
1	Dominion Virginia Power	Larry Nash	Negative	SUPPORTS THIRD PARTY COMMENTS -

				(Dominion)
1	Duke Energy Carolina	Doug E Hills	Negative	SUPPORTS THIRD PARTY COMMENTS - (Duke Energy)
1	Empire District Electric Co.	Ralph F Meyer		
1	Encari	Steven E Hamburg		
1	Entergy Transmission	Oliver A Burke	Negative	COMMENT RECEIVED
1	FirstEnergy Corp.	William J Smith	Affirmative	
1	Florida Keys Electric Cooperative Assoc.	Dennis Minton	Negative	SUPPORTS THIRD PARTY COMMENTS - (PSEG)
1	Florida Power & Light Co.	Mike O'Neil		
1	Gainesville Regional Utilities	Richard Bachmeier		
1	Georgia Transmission Corporation	Jason Snodgrass	Affirmative	
1	Great River Energy	Gordon Pietsch	Affirmative	
1	Hydro One Networks, Inc.	Muhammed Ali	Affirmative	
1	Hydro-Quebec TransEnergie	Martin Boisvert	Affirmative	
1	Idaho Power Company	Molly Devine	Affirmative	
1	International Transmission Company Holdings Corp	Michael Moltane	Negative	COMMENT RECEIVED
1	JDRJC Associates	Jim D Cyrulewski		
1	JEA	Ted E Hobson		
1	KAMO Electric Cooperative	Walter Kenyon	Negative	SUPPORTS THIRD PARTY COMMENTS - (AECI)
1	Kansas City Power & Light Co.	Daniel Gibson		
1	Keys Energy Services	Stanley T Rzad		
1	Lakeland Electric	Larry E Watt	Negative	SUPPORTS THIRD PARTY COMMENTS - (FMPA)
1	Lee County Electric Cooperative	John Chin		
1	Los Angeles Department of Water & Power	faranak sarbaz	Abstain	
1	Lower Colorado River Authority	Martyn Turner	Negative	SUPPORTS THIRD PARTY COMMENTS - (Lower Colorado River Authority)
1	Manitoba Hydro	Jo-Anne M Ross	Affirmative	
1	MEAG Power	Danny Dees	Affirmative	
1	MidAmerican Energy Co.	Terry Harbour		
1	Minnkota Power Coop. Inc.	Daniel L Inman	Abstain	
1	N.W. Electric Power Cooperative, Inc.	Mark Ramsey	Negative	SUPPORTS THIRD PARTY COMMENTS - (AECI)
1	National Grid USA	Michael Jones	Affirmative	
1	NB Power Corporation	Alan MacNaughton	Abstain	
1	Nebraska Public Power District	Jamison Cawley	Negative	COMMENT RECEIVED
1	New York Power Authority	Bruce Metruck	Affirmative	
1	Northeast Missouri Electric Power Cooperative	Kevin White	Negative	SUPPORTS THIRD PARTY COMMENTS - (AECI)
1	Northeast Utilities	William Temple		
1	Northern Indiana Public Service Co.	Julaine Dyke	Negative	SUPPORTS THIRD PARTY COMMENTS - (Joe O'Brien NIPSCO)
1	NorthWestern Energy	John Canavan		
1	Ohio Valley Electric Corp.	Scott R Cunningham	Affirmative	
1	Oklahoma Gas and Electric Co.	Terri Pyle		
1	Omaha Public Power District	Doug Peterchuck	Affirmative	
1	Oncor Electric Delivery	Jen Fiegel	Affirmative	
1	Otter Tail Power Company	Daryl Hanson		
1	Pacific Gas and Electric Company	Bangalore Vijayraghavan		

1	Peak Reliability	Jared Shakespeare		
1	Platte River Power Authority	John C. Collins	Negative	SUPPORTS THIRD PARTY COMMENTS - (Public Service Enterprise Group (PSEG))
1	Portland General Electric Co.	John T Walker	Affirmative	
1	Potomac Electric Power Co.	David Thorne	Negative	COMMENT RECEIVED
1	PPL Electric Utilities Corp.	Brenda L Truhe		
1	Public Service Company of New Mexico	Laurie Williams	Abstain	
1	Public Service Electric and Gas Co.	Kenneth D. Brown	Negative	COMMENT RECEIVED
1	Public Utility District No. 1 of Okanogan County	Dale Dunckel	Abstain	
1	Puget Sound Energy, Inc.	Denise M Lietz	Negative	SUPPORTS THIRD PARTY COMMENTS - (Eleanor Ewry, Puget Sound Energy)
1	Rochester Gas and Electric Corp.	John C. Allen	Affirmative	
1	Sacramento Municipal Utility District	Tim Kelley	Affirmative	
1	Salt River Project	Robert Kondziolka	Affirmative	
1	SaskPower	Wayne Guttormson		
1	Seattle City Light	Pawel Krupa	Negative	SUPPORTS THIRD PARTY COMMENTS - (Seattle City Light Paul Haase's comment)
1	Seminole Electric Cooperative, Inc.	Glenn Spurlock	Negative	SUPPORTS THIRD PARTY COMMENTS - (Seminole Corporate Compliance)
1	Sho-Me Power Electric Cooperative	Denise Stevens	Negative	SUPPORTS THIRD PARTY COMMENTS - (AECI)
1	Snohomish County PUD No. 1	Long T Duong		
1	South Carolina Electric & Gas Co.	Tom Hanzlik		
1	South Carolina Public Service Authority	Shawn T Abrams	Negative	COMMENT RECEIVED
1	Southern California Edison Company	Steven Mavis	Affirmative	
1	Southern Company Services, Inc.	Robert A. Schaffeld	Negative	SUPPORTS THIRD PARTY COMMENTS - (Southern Company)
1	Southern Illinois Power Coop.	William Hutchison	Affirmative	
1	Southwest Transmission Cooperative, Inc.	John Shaver	Affirmative	
1	Sunflower Electric Power Corporation	Noman Lee Williams	Affirmative	
1	Tampa Electric Co.	Beth Young		
1	Tennessee Valley Authority	Howell D Scott	Negative	COMMENT RECEIVED
1	Trans Bay Cable LLC	Steven Powell		
1	Tri-State Generation & Transmission Association, Inc.	Tracy Sliaman	Affirmative	
1	Tucson Electric Power Co.	John Tolo		
1	U.S. Bureau of Reclamation	Richard T Jackson		
1	United Illuminating Co.	Jonathan Appelbaum	Affirmative	
1	Vermont Electric Power Company, Inc.	Kim Moulton		
1	Westar Energy	Allen Klassen	Negative	SUPPORTS THIRD PARTY COMMENTS - (SPP Standards Group)
1	Western Area Power Administration	Lloyd A Linke	Affirmative	
1	Wolverine Power Supply Coop., Inc.	Michelle Clements		

1	Xcel Energy, Inc.	Gregory L Pieper	Negative	SUPPORTS THIRD PARTY COMMENTS - (Amy Casusceli, Xcel Energy)
2	BC Hydro	Venkataramakrishnan Vinnakota	Negative	SUPPORTS THIRD PARTY COMMENTS - (Public Service Enterprise Group) - (Patricia Robertson)
2	California ISO	Rich Vine		
2	Electric Reliability Council of Texas, Inc.	Cheryl Moseley	Affirmative	
2	Independent Electricity System Operator	Leonard Kula	Negative	COMMENT RECEIVED
2	ISO New England, Inc.	Matthew F Goldberg	Negative	COMMENT RECEIVED
2	MISO	Marie Knox	Negative	SUPPORTS THIRD PARTY COMMENTS - (ISO/RTO SRC)
2	New York Independent System Operator	Gregory Campoli		
2	PJM Interconnection, L.L.C.	stephanie monzon	Affirmative	
2	Southwest Power Pool, Inc.	Charles H. Yeung	Negative	COMMENT RECEIVED
3	AEP	Michael E DeLoach	Affirmative	
3	Alabama Power Company	Robert S Moore	Negative	SUPPORTS THIRD PARTY COMMENTS - (Southern Company)
3	Ameren Corp.	David J Jendras	Negative	COMMENT RECEIVED
3	APS	Sarah Kist	Affirmative	
3	Associated Electric Cooperative, Inc.	Todd Bennett	Negative	SUPPORTS THIRD PARTY COMMENTS - (AECI)
3	Atlantic City Electric Company	NICOLE BUCKMAN	Negative	SUPPORTS THIRD PARTY COMMENTS - (Pepco Holdings Inc.)
3	Avista Corp.	Scott J Kinney		
3	BC Hydro and Power Authority	Pat G. Harrington	Negative	SUPPORTS THIRD PARTY COMMENTS - (Public Service Enterprise Group)
3	Central Electric Power Cooperative	Adam M Weber	Negative	SUPPORTS THIRD PARTY COMMENTS - (AECI)
3	City of Austin dba Austin Energy	Andrew Gallo	Negative	SUPPORTS THIRD PARTY COMMENTS - (Luminant Generation Company, LLC)
3	City of Clewiston	Lynne Mila	Negative	SUPPORTS THIRD PARTY COMMENTS - (FMPA)
3	City of Farmington	Linda R Jacobson	Abstain	
3	City of Green Cove Springs	Mark Schultz	Negative	SUPPORTS THIRD PARTY COMMENTS - (FMPA)
3	City of Redding	Bill Hughes	Affirmative	
				SUPPORTS THIRD PARTY



3	City of Tallahassee	Bill R Fowler	Negative	COMMENTS - (PSEG)
3	Colorado Springs Utilities	Jean Mueller	Negative	SUPPORTS THIRD PARTY COMMENTS - (Kaleb Brimhall, CSU)
3	ComEd	John Bee	Affirmative	
3	Consolidated Edison Co. of New York	Peter T Yost	Affirmative	
3	Consumers Energy Company	Gerald G Farringer	Negative	COMMENT RECEIVED
3	Cowlitz County PUD	Russell A Noble	Affirmative	
3	CPS Energy	Jose Escamilla	Negative	SUPPORTS THIRD PARTY COMMENTS - (Glenn Pressler's comments submitted on behalf of CPS Energy)
3	Delmarva Power & Light Co.	Michael R. Mayer	Negative	SUPPORTS THIRD PARTY COMMENTS - (Pepco Holdings Inc.)
3	Dominion Resources, Inc.	Connie B Lowe	Negative	SUPPORTS THIRD PARTY COMMENTS - (Dominion's)
3	DTE Electric	Kent Kujala	Negative	COMMENT RECEIVED
3	FirstEnergy Corp.	Cindy E Stewart	Affirmative	
3	Florida Keys Electric Cooperative	Tom B Anthony	Affirmative	
3	Florida Municipal Power Agency	Joe McKinney	Negative	COMMENT RECEIVED
3	Florida Power & Light Co.	Summer C. Esquerre		
3	Florida Power Corporation	Lee Schuster	Negative	SUPPORTS THIRD PARTY COMMENTS - (Duke Energy)
3	Georgia System Operations Corporation	Scott McGough	Affirmative	
3	Great River Energy	Brian Glover	Affirmative	
3	Hydro One Networks, Inc.	Ayesha Sabouba	Affirmative	
3	JEA	Garry Baker		
3	Kansas City Power & Light Co.	Joshua D Bach	Negative	COMMENT RECEIVED
3	Lakeland Electric	Mace D Hunter	Negative	SUPPORTS THIRD PARTY COMMENTS - (Public Service Enterprise Group)
3	Lee County Electric Cooperative	David A Hadzima		
3	Lincoln Electric System	Jason Fortik	Negative	COMMENT RECEIVED
3	Los Angeles Department of Water & Power	Mike Anctil		
3	Louisville Gas and Electric Co.	Charles A. Freibert	Negative	SUPPORTS THIRD PARTY COMMENTS - (PPL NERC Registered Affiliates)
3	Manitoba Hydro	Greg C. Parent	Affirmative	
3	MEAG Power	Roger Brand	Affirmative	
3	MidAmerican Energy Co.	Thomas C. Mielnik		
3	Modesto Irrigation District	Jack W Savage	Affirmative	
3	Muscatine Power & Water	John S Bos	Affirmative	
3	National Grid USA	Brian E Shanahan		
3	Nebraska Public Power District	Tony Eddleman	Negative	SUPPORTS THIRD PARTY COMMENTS - (I support comments by Nebraska

				Public Power District and Southwest Power Pool.)
3	New York Power Authority	David R Rivera	Affirmative	
3	Northern Indiana Public Service Co.	Ramon J Barany	Negative	SUPPORTS THIRD PARTY COMMENTS - (See Joe O'Brien's Comments)
3	NW Electric Power Cooperative, Inc.	David McDowell	Negative	SUPPORTS THIRD PARTY COMMENTS - (AECI)
3	Ocala Utility Services	Randy Hahn	Negative	SUPPORTS THIRD PARTY COMMENTS - (FMPPA)
3	Oklahoma Gas and Electric Co.	Donald Hargrove		
3	Omaha Public Power District	Blaine R. Dinwiddie	Affirmative	
3	Orlando Utilities Commission	Ballard K Mutters		
3	Owensboro Municipal Utilities	Thomas T Lyons	Affirmative	
3	Pacific Gas and Electric Company	John H Hagen	Affirmative	
3	Platte River Power Authority	Terry L Baker	Negative	SUPPORTS THIRD PARTY COMMENTS - (PSEG)
3	PNM Resources	Michael Mertz	Abstain	
3	Portland General Electric Co.	Thomas G Ward	Affirmative	
3	Potomac Electric Power Co.	Mark Yerger	Negative	SUPPORTS THIRD PARTY COMMENTS - (Pepco Holdings Inc.)
3	Public Service Electric and Gas Co.	Jeffrey Mueller	Negative	SUPPORTS THIRD PARTY COMMENTS - (Public Service Enterprise Group)
3	Puget Sound Energy, Inc.	Mariah R Kennedy	Negative	COMMENT RECEIVED
3	Sacramento Municipal Utility District	James Leigh-Kendall	Affirmative	
3	Salt River Project	John T. Underhill	Affirmative	
3	Santee Cooper	James M Poston	Negative	COMMENT RECEIVED
3	Seattle City Light	Dana Wheelock	Negative	SUPPORTS THIRD PARTY COMMENTS - (Seattle City Light Paul Haase's comment)
3	Seminole Electric Cooperative, Inc.	James R Frauen	Negative	SUPPORTS THIRD PARTY COMMENTS - (Seminole Electric Cooperative)
3	Sho-Me Power Electric Cooperative	Jeff L Neas	Negative	SUPPORTS THIRD PARTY COMMENTS - (AECI)
3	Snohomish County PUD No. 1	Mark Oens		
3	South Carolina Electric & Gas Co.	Hubert C Young		
3	Southern California Edison Company	Lujuanna Medina	Affirmative	
3	Tacoma Power	Marc Donaldson	Affirmative	
3	Tampa Electric Co.	Ronald L. Donahey		
3	Tennessee Valley Authority	Ian S Grant	Abstain	
3	Tri-State Generation & Transmission Association, Inc.	Janelle Marriott	Affirmative	
3	Westar Energy	Bo Jones	Negative	SUPPORTS THIRD PARTY COMMENTS - (SPP)

				Standards Group)
3	Xcel Energy, Inc.	Michael Ibold	Negative	SUPPORTS THIRD PARTY COMMENTS - (Xcel Energy)
4	Alliant Energy Corp. Services, Inc.	Kenneth Goldsmith		
4	Blue Ridge Power Agency	Duane S Dahlquist	Affirmative	
4	City of Austin dba Austin Energy	Reza Ebrahimian	Negative	SUPPORTS THIRD PARTY COMMENTS - (Luminant Generation Company, LLC)
4	City of Redding	Nicholas Zettel	Affirmative	
4	City Utilities of Springfield, Missouri	John Allen	Negative	SUPPORTS THIRD PARTY COMMENTS - (SPP Standards Review Group)
4	Consumers Energy Company	Tracy Goble	Negative	SUPPORTS THIRD PARTY COMMENTS - (Kurt LaFrance)
4	Cowlitz County PUD	Rick Syring	Affirmative	
4	DTE Electric	Daniel Herring	Negative	COMMENT RECEIVED
4	Florida Municipal Power Agency	Frank Gaffney	Negative	COMMENT RECEIVED
4	Georgia System Operations Corporation	Guy Andrews	Affirmative	
4	Herb Schrayshuen	Herb Schrayshuen	Affirmative	
4	Illinois Municipal Electric Agency	Bob C. Thomas	Abstain	
4	Indiana Municipal Power Agency	Jack Alvey	Negative	SUPPORTS THIRD PARTY COMMENTS - (Public Service Enterprise Group)
4	Madison Gas and Electric Co.	Joseph DePoorter	Abstain	
4	Modesto Irrigation District	Spencer Tacke		
4	Ohio Edison Company	Douglas Hohlbauh	Affirmative	
4	Oklahoma Municipal Power Authority	Ashley Stringer	Negative	SUPPORTS THIRD PARTY COMMENTS - (Southwest Power Pool)
4	Old Dominion Electric Coop.	Mark Ringhausen		
4	Public Utility District No. 1 of Snohomish County	John D Martinsen		
4	Sacramento Municipal Utility District	Mike Ramirez	Affirmative	
4	Seattle City Light	Hao Li	Negative	SUPPORTS THIRD PARTY COMMENTS - (Seattle City Light Paul Haase's comment)
4	Seminole Electric Cooperative, Inc.	Steven R Wallace	Negative	SUPPORTS THIRD PARTY COMMENTS - (Seminole Electric Cooperative Comments submitted by Maryclaire Yatsko.)
4	South Mississippi Electric Power Association	Steve McElhaney		
4	Tacoma Public Utilities	Keith Morisette	Affirmative	
4	Utility Services, Inc.	Brian Evans-Mongeon	Abstain	
5	Amerenue	Sam Dwyer	Negative	SUPPORTS THIRD PARTY COMMENTS -

				(Ameren's comments)
5	American Electric Power	Thomas Foltz	Affirmative	
5	Arizona Public Service Co.	Scott Takinen	Affirmative	
5	Associated Electric Cooperative, Inc.	Matthew Pacobit	Negative	SUPPORTS THIRD PARTY COMMENTS - (AECI)
5	BC Hydro and Power Authority	Clement Ma	Negative	SUPPORTS THIRD PARTY COMMENTS - (Public Service Enterprise Group)
5	Boise-Kuna Irrigation District/dba Lucky peak power plant project	Mike D Kukla	Negative	SUPPORTS THIRD PARTY COMMENTS - (SCL comments)
5	Bonneville Power Administration	Francis J. Halpin	Affirmative	
5	Brazos Electric Power Cooperative, Inc.	Shari Heino	Negative	SUPPORTS THIRD PARTY COMMENTS - (ACES)
5	City and County of San Francisco	Daniel Mason	Abstain	
5	City of Austin dba Austin Energy	Jeanie Doty	Negative	SUPPORTS THIRD PARTY COMMENTS - (Luminant Generation Company, LLC)
5	City of Redding	Paul A. Cummings	Affirmative	
5	City of Tallahassee	Karen Webb	Negative	SUPPORTS THIRD PARTY COMMENTS - (PSEG)
5	City Water, Light & Power of Springfield	Steve Rose		
5	Cleco Power	Stephanie Huffman	Negative	SUPPORTS THIRD PARTY COMMENTS - (See PSEG comments)
5	Cogentrix Energy Power Management, LLC	Mike D Hirst		
5	Colorado Springs Utilities	Kaleb Brimhall	Negative	SUPPORTS THIRD PARTY COMMENTS - (Colorado Springs Utilities)
5	Con Edison Company of New York	Brian O'Boyle	Affirmative	
5	Consumers Energy Company	David C Greyerbiehl	Negative	SUPPORTS THIRD PARTY COMMENTS - (Kurt LaFrance)
5	Cowlitz County PUD	Bob Essex	Affirmative	
5	Dairyland Power Coop.	Tommy Drea		
5	Dominion Resources, Inc.	Mike Garton	Negative	SUPPORTS THIRD PARTY COMMENTS - (Dominion)
5	DTE Electric	Mark Stefaniak	Negative	SUPPORTS THIRD PARTY COMMENTS - (DTE Electric)
5	Duke Energy	Dale Q Goodwine	Negative	SUPPORTS THIRD PARTY COMMENTS - (Duke Energy)
5	Dynegy Inc.	Dan Roethemeyer	Negative	SUPPORTS THIRD PARTY COMMENTS - (PSEG)
5	E.ON Climate & Renewables North America, LLC	Dana Showalter		
				SUPPORTS

5	Entergy Services, Inc.	Tracey Stubbs	Negative	THIRD PARTY COMMENTS - (Entergy Transmission)
5	Exelon Nuclear	Mark F Draper	Affirmative	
5	First Wind	John Robertson		
5	FirstEnergy Solutions	Kenneth Dresner	Affirmative	
5	Florida Municipal Power Agency	David Schumann	Negative	COMMENT RECEIVED
5	Great River Energy	Preston L Walsh	Affirmative	
5	Hydro-Québec Production	Roger Dufresne	Affirmative	
5	Ingleside Cogeneration LP	Michelle R DAntuono	Abstain	
5	JEA	John J Babik		
5	Kansas City Power & Light Co.	Brett Holland	Negative	COMMENT RECEIVED
5	Kissimmee Utility Authority	Mike Blough	Negative	SUPPORTS THIRD PARTY COMMENTS - (Florida Municipal Power Agency)
5	Lakeland Electric	James M Howard	Negative	SUPPORTS THIRD PARTY COMMENTS - (Florida Municipal Power Agency)
5	Liberty Electric Power LLC	Daniel Duff		
5	Lincoln Electric System	Dennis Florom	Negative	COMMENT RECEIVED
5	Los Angeles Department of Water & Power	Kenneth Silver		
5	Lower Colorado River Authority	Dixie Wells	Negative	COMMENT RECEIVED
5	Luminant Generation Company LLC	Rick Terrill	Negative	SUPPORTS THIRD PARTY COMMENTS - (Luminant Generation comments submitted by Alshare Hughes)
5	Manitoba Hydro	Chris Mazur	Affirmative	
5	Massachusetts Municipal Wholesale Electric Company	David Gordon	Abstain	
5	MEAG Power	Steven Grego	Affirmative	
5	Muscatine Power & Water	Mike Avesing	Affirmative	
5	Nebraska Public Power District	Don Schmit	Negative	SUPPORTS THIRD PARTY COMMENTS - (NPPD)
5	New York Power Authority	Wayne Sipperly	Affirmative	
5	NextEra Energy	Allen D Schriver	Affirmative	
5	North Carolina Electric Membership Corp.	Jeffrey S Brame	Affirmative	
5	Northern Indiana Public Service Co.	Michael D Melvin	Negative	SUPPORTS THIRD PARTY COMMENTS - (See Joe O'Brien NIPSCO comments.)
5	Oglethorpe Power Corporation	Bernard Johnson	Affirmative	
5	Oklahoma Gas and Electric Co.	Henry L Staples		
5	Omaha Public Power District	Mahmood Z. Safi	Affirmative	
5	Pacific Gas and Electric Company	Alex Chua		
5	Platte River Power Authority	Christopher R Wood	Negative	SUPPORTS THIRD PARTY COMMENTS - (PSEG)
5	Portland General Electric Co.	Matt E. Jastram		
5	PPL Generation LLC	Annette M Bannon	Negative	SUPPORTS THIRD PARTY COMMENTS - (PPL NERC Registered)

				Affiliates)
5	PSEG Fossil LLC	Tim Kucey	Negative	SUPPORTS THIRD PARTY COMMENTS - (PSEG (John Seelke))
5	Public Utility District No. 1 of Lewis County	Steven Grega	Negative	SUPPORTS THIRD PARTY COMMENTS - (PSEG comments)
5	Public Utility District No. 2 of Grant County, Washington	Michiko Sell	Abstain	
5	Puget Sound Energy, Inc.	Lynda Kupfer	Negative	SUPPORTS THIRD PARTY COMMENTS - (Ewry, Eleanor)
5	Sacramento Municipal Utility District	Susan Gill-Zobitz	Affirmative	
5	Salt River Project	William Alkema	Affirmative	
5	Santee Cooper	Lewis P Pierce	Negative	COMMENT RECEIVED
5	Seattle City Light	Michael J. Haynes	Negative	SUPPORTS THIRD PARTY COMMENTS - (Haase, Seattle)
5	Snohomish County PUD No. 1	Sam Nietfeld		
5	South Carolina Electric & Gas Co.	Edward Magic		
5	Southern California Edison Company	Denise Yaffe	Affirmative	
5	Southern Company Generation	William D Shultz	Negative	SUPPORTS THIRD PARTY COMMENTS - (Southern Company)
5	Tacoma Power	Chris Mattson	Affirmative	
5	Tampa Electric Co.	RJames Rocha	Abstain	
5	Tenaska, Inc.	Scott M. Helyer		
5	Tennessee Valley Authority	David Thompson	Negative	COMMENT RECEIVED
5	Tri-State Generation & Transmission Association, Inc.	Mark Stein	Affirmative	
5	U.S. Army Corps of Engineers	Melissa Kurtz		
5	USDI Bureau of Reclamation	Erika Doot		
5	Westar Energy	Bryan Taggart	Negative	SUPPORTS THIRD PARTY COMMENTS - (SPP's)
5	Xcel Energy, Inc.	Mark A Castagneri	Negative	COMMENT RECEIVED
6	AEP Marketing	Edward P. Cox	Affirmative	
6	Ameren Missouri	Robert Quinlivan	Negative	SUPPORTS THIRD PARTY COMMENTS - (Ameren)
6	APS	Randy A. Young	Affirmative	
6	Associated Electric Cooperative, Inc.	Brian Ackermann	Negative	SUPPORTS THIRD PARTY COMMENTS - (AECI)
6	Bonneville Power Administration	Brenda S. Anderson	Affirmative	
6	City of Austin dba Austin Energy	Lisa Martin	Negative	SUPPORTS THIRD PARTY COMMENTS - (Luminant Generation Company, LLC)
6	City of Redding	Marvin Briggs	Affirmative	
6	Cleco Power LLC	Robert Hirschak	Negative	SUPPORTS THIRD PARTY COMMENTS - (See PSEG comments)
				SUPPORTS THIRD PARTY

6	Colorado Springs Utilities	Shannon Fair	Negative	COMMENTS - (Colorado Springs Utilities)
6	Con Edison Company of New York	David Balban	Affirmative	
6	Constellation Energy Commodities Group	David J Carlson	Affirmative	
6	Dominion Resources, Inc.	Louis S. Slade	Negative	SUPPORTS THIRD PARTY COMMENTS - (Dominion)
6	Duke Energy	Greg Cecil	Negative	SUPPORTS THIRD PARTY COMMENTS - (Duke Energy)
6	FirstEnergy Solutions	Kevin Querry	Affirmative	
6	Florida Municipal Power Agency	Richard L. Montgomery	Negative	COMMENT RECEIVED
6	Florida Municipal Power Pool	Thomas Washburn		
6	Florida Power & Light Co.	Silvia P Mitchell	Affirmative	
6	Great River Energy	Donna Stephenson	Affirmative	
6	Kansas City Power & Light Co.	Jessica L Klinghoffer	Negative	COMMENT RECEIVED
6	Lakeland Electric	Paul Shipps	Negative	SUPPORTS THIRD PARTY COMMENTS - (FMPA)
6	Lincoln Electric System	Eric Ruskamp	Negative	COMMENT RECEIVED
6	Lower Colorado River Authority	Michael Shaw	Negative	SUPPORTS THIRD PARTY COMMENTS - (Dixie Wells)
6	Luminant Energy	Brenda Hampton	Negative	SUPPORTS THIRD PARTY COMMENTS - (Luminant Generation Company, LLC)
6	Manitoba Hydro	Blair Mukanik	Affirmative	
6	Modesto Irrigation District	James McFall	Affirmative	
6	New York Power Authority	Shivaz Chopra	Affirmative	
6	Northern Indiana Public Service Co.	Joseph O'Brien	Negative	COMMENT RECEIVED
6	Oglethorpe Power Corporation	Donna Johnson	Affirmative	
6	Oklahoma Gas and Electric Co.	Jerry Nottnagel		
6	Omaha Public Power District	Douglas Collins	Affirmative	
6	PacifiCorp	Sandra L Shaffer	Affirmative	
6	Platte River Power Authority	Carol Ballantine	Negative	SUPPORTS THIRD PARTY COMMENTS - (PSEG)
6	Portland General Electric Co.	Shawn P Davis	Affirmative	
6	Power Generation Services, Inc.	Stephen C Knapp		
6	Powerex Corp.	Gordon Dobson-Mack		
6	PPL EnergyPlus LLC	Elizabeth Davis	Negative	SUPPORTS THIRD PARTY COMMENTS - (PPL NERC Registered Affiliates)
6	PSEG Energy Resources & Trade LLC	Peter Dolan	Negative	SUPPORTS THIRD PARTY COMMENTS - (Public Service Enterprise Group)
6	Public Utility District No. 1 of Chelan County	Hugh A. Owen	Abstain	
6	Sacramento Municipal Utility District	Diane Enderby	Affirmative	
6	Salt River Project	William Abraham	Affirmative	
6	Santee Cooper	Michael Brown	Negative	COMMENT RECEIVED
6	Seattle City Light	Dennis Sismaet	Negative	SUPPORTS THIRD PARTY COMMENTS -

				(Paul Haase)
6	Seminole Electric Cooperative, Inc.	Trudy S. Novak	Negative	SUPPORTS THIRD PARTY COMMENTS - (Seminole Electric Cooperative's Corporate Compliance department)
6	Snohomish County PUD No. 1	Kenn Backholm		
6	Southern California Edison Company	Joseph T Marone	Affirmative	
6	Southern Company Generation and Energy Marketing	John J. Ciza	Negative	SUPPORTS THIRD PARTY COMMENTS - (Southern Company)
6	Tacoma Public Utilities	Michael C Hill	Affirmative	
6	Tampa Electric Co.	Benjamin F Smith II		
6	Tennessee Valley Authority	Marjorie S. Parsons	Negative	COMMENT RECEIVED
6	Westar Energy	Grant L Wilkerson	Negative	SUPPORTS THIRD PARTY COMMENTS - (SPP Standards Group)
6	Western Area Power Administration - UGP Marketing	Peter H Kinney		
6	Xcel Energy, Inc.	Peter Colussy	Negative	COMMENT RECEIVED
7	Occidental Chemical	Venona Greaff		
7	Siemens Energy, Inc.	Frank R. McElvain		
8		David L Kiguel	Affirmative	
8		Roger C Zaklukiewicz	Affirmative	
8	Massachusetts Attorney General	Frederick R Plett	Affirmative	
8	Volkman Consulting, Inc.	Terry Volkman	Affirmative	
9	Commonwealth of Massachusetts Department of Public Utilities	Donald Nelson	Affirmative	
9	New York State Public Service Commission	Diane J Barney		
10	Florida Reliability Coordinating Council	Linda C Campbell	Affirmative	
10	Midwest Reliability Organization	Russel Mountjoy	Affirmative	
10	New York State Reliability Council	Alan Adamson	Affirmative	
10	Northeast Power Coordinating Council	Guy V. Zito	Affirmative	
10	ReliabilityFirst	Anthony E Jablonski	Affirmative	
10	SERC Reliability Corporation	Joseph W Spencer	Affirmative	
10	Southwest Power Pool RE	Bob Reynolds	Affirmative	
10	Texas Reliability Entity, Inc.	Karin Schweitzer	Affirmative	
10	Western Electricity Coordinating Council	Steven L. Rueckert	Abstain	

Legal and Privacy : 404.446.2560 voice : 404.467.0474 fax : 3353 Peachtree Road, N.E. : Suite 600, North Tower : Atlanta, GA 30326  
Washington Office: 1325 G Street, N.W. : Suite 600 : Washington, DC 20005-3801

 [Account Log-In/Register](#)

Copyright © 2014 by the North American Electric Reliability Corporation. : All rights reserved.  
A New Jersey Nonprofit Corporation



## Non-Binding Poll Results

### Project 2010-13.3 Phase 3 of Relay Loadability: Stable Power Swings PRC-026-1

Non-Binding Poll Results	
<b>Non-Binding Poll Name:</b>	Project 2010-13.3 Relay Loadability Stable Power Swings PRC-026-1
<b>Poll Period:</b>	9/26/2014 - 10/6/2014
<b>Total # Opinions:</b>	258
<b>Total Ballot Pool:</b>	332
<b>Summary Results:</b>	77.71% of those who registered to participate provided an opinion or an abstention; 51.71% of those who provided an opinion indicated support for the VRFs and VSLs.

Individual Ballot Pool Results				
Segment	Organization	Member	Opinions	NERC Notes
1	Ameren Services	Eric Scott	Abstain	
1	American Electric Power	Paul B Johnson	Abstain	
1	Arizona Public Service Co.	Robert Smith		
1	Associated Electric Cooperative, Inc.	John Bussman	Negative	SUPPORTS THIRD PARTY COMMENTS - (AECI)
1	ATCO Electric	Glen Sutton	Negative	SUPPORTS THIRD PARTY COMMENTS - (PSEG)
1	Austin Energy	James Armke	Negative	SUPPORTS THIRD PARTY COMMENTS - (Luminant Generation Company, LLC)
1	Avista Utilities	Heather Rosentrater		
1	Balancing Authority of Northern California	Kevin Smith	Affirmative	
1	BC Hydro and Power Authority	Patricia Robertson	Abstain	

1	Brazos Electric Power Cooperative, Inc.	Tony Kroskey		
1	Bryan Texas Utilities	John C Fontenot	Affirmative	
1	CenterPoint Energy Houston Electric, LLC	John Brockhan	Abstain	
1	Central Electric Power Cooperative	Michael B Bax	Negative	SUPPORTS THIRD PARTY COMMENTS - (AECI)
1	Central Iowa Power Cooperative	Kevin J Lyons	Negative	SUPPORTS THIRD PARTY COMMENTS - (ACES)
1	City of Tacoma, Department of Public Utilities, Light Division, dba Tacoma Power	Chang G Choi	Affirmative	
1	City of Tallahassee	Daniel S Langston	Negative	SUPPORTS THIRD PARTY COMMENTS - (PSEG)
1	Clark Public Utilities	Jack Stamper	Negative	SUPPORTS THIRD PARTY COMMENTS - (PSEG)
1	Colorado Springs Utilities	Shawna Speer		
1	Consolidated Edison Co. of New York	Christopher L de Graffenried	Affirmative	
1	CPS Energy	Glenn Pressler	Negative	COMMENT RECEIVED
1	Dairyland Power Coop.	Robert W. Roddy		
1	Deseret Power	James Tucker	Negative	SUPPORTS THIRD PARTY COMMENTS - (PSEG)
1	Dominion Virginia Power	Larry Nash	Abstain	
1	Duke Energy Carolina	Doug E Hils	Negative	SUPPORTS THIRD PARTY COMMENTS - (Duke Energy)
1	Empire District Electric Co.	Ralph F Meyer		
1	Encari	Steven E Hamburg		
1	Entergy Transmission	Oliver A Burke	Negative	COMMENT RECEIVED
1	FirstEnergy Corp.	William J Smith	Affirmative	
1	Florida Keys Electric Cooperative Assoc.	Dennis Minton	Negative	SUPPORTS THIRD PARTY COMMENTS - (PSEG)
1	Florida Power & Light Co.	Mike O'Neil		
1	Gainesville Regional Utilities	Richard Bachmeier		
1	Georgia Transmission Corporation	Jason Snodgrass	Affirmative	
1	Great River Energy	Gordon Pietsch	Affirmative	

1	Hydro One Networks, Inc.	Muhammed Ali	Affirmative	
1	Hydro-Quebec TransEnergie	Martin Boisvert	Affirmative	
1	Idaho Power Company	Molly Devine	Affirmative	
1	International Transmission Company Holdings Corp	Michael Moltane		
1	JDRJC Associates	Jim D Cyrulewski		
1	JEA	Ted E Hobson		
1	KAMO Electric Cooperative	Walter Kenyon	Negative	SUPPORTS THIRD PARTY COMMENTS - (AECI)
1	Kansas City Power & Light Co.	Daniel Gibson		
1	Lakeland Electric	Larry E Watt	Negative	SUPPORTS THIRD PARTY COMMENTS - (FMFA)
1	Lee County Electric Cooperative	John Chin		
1	Los Angeles Department of Water & Power	faranak sarbaz	Abstain	
1	Lower Colorado River Authority	Martyn Turner	Negative	SUPPORTS THIRD PARTY COMMENTS - (Lower Colorado River Authority)
1	Manitoba Hydro	Jo-Anne M Ross	Affirmative	
1	MEAG Power	Danny Dees	Affirmative	
1	MidAmerican Energy Co.	Terry Harbour		
1	Minnkota Power Coop. Inc.	Daniel L Inman	Abstain	
1	N.W. Electric Power Cooperative, Inc.	Mark Ramsey	Negative	SUPPORTS THIRD PARTY COMMENTS - (AECI)
1	National Grid USA	Michael Jones	Affirmative	
1	NB Power Corporation	Alan MacNaughton	Abstain	
1	Nebraska Public Power District	Jamison Cawley	Abstain	
1	New York Power Authority	Bruce Metruck	Affirmative	
1	Northeast Missouri Electric Power Cooperative	Kevin White	Negative	SUPPORTS THIRD PARTY COMMENTS - (AECI)
1	Northeast Utilities	William Temple		
1	Northern Indiana Public Service Co.	Julaine Dyke	Negative	SUPPORTS THIRD PARTY COMMENTS - (Joe O'Brien NIPSCO)
1	NorthWestern Energy	John Canavan		
1	Ohio Valley Electric Corp.	Scott R Cunningham	Abstain	

1	Oklahoma Gas and Electric Co.	Terri Pyle		
1	Omaha Public Power District	Doug Peterchuck	Affirmative	
1	Oncor Electric Delivery	Jen Fiegel	Affirmative	
1	Otter Tail Power Company	Daryl Hanson		
1	Pacific Gas and Electric Company	Bangalore Vijayraghavan		
1	Peak Reliability	Jared Shakespeare		
1	Platte River Power Authority	John C. Collins	Abstain	
1	Portland General Electric Co.	John T Walker	Affirmative	
1	PPL Electric Utilities Corp.	Brenda L Truhe		
1	Public Service Company of New Mexico	Laurie Williams	Abstain	
1	Public Service Electric and Gas Co.	Kenneth D. Brown	Abstain	
1	Public Utility District No. 1 of Okanogan County	Dale Dunckel	Abstain	
1	Puget Sound Energy, Inc.	Denise M Lietz	Negative	SUPPORTS THIRD PARTY COMMENTS - (Eleanor Ewry, Puget Sound Energy)
1	Rochester Gas and Electric Corp.	John C. Allen	Affirmative	
1	Sacramento Municipal Utility District	Tim Kelley	Affirmative	
1	Salt River Project	Robert Kondziolka	Affirmative	
1	SaskPower	Wayne Guttormson		
1	Seminole Electric Cooperative, Inc.	Glenn Spurlock	Abstain	
1	Sho-Me Power Electric Cooperative	Denise Stevens	Negative	SUPPORTS THIRD PARTY COMMENTS - (AECI)
1	Snohomish County PUD No. 1	Long T Duong		
1	South Carolina Electric & Gas Co.	Tom Hanzlik		
1	South Carolina Public Service Authority	Shawn T Abrams	Negative	COMMENT RECEIVED
1	Southern California Edison Company	Steven Mavis	Affirmative	
1	Southern Company Services, Inc.	Robert A. Schaffeld	Negative	SUPPORTS THIRD PARTY COMMENTS - (Southern Company)
1	Southern Illinois Power Coop.	William Hutchison	Affirmative	
1	Southwest Transmission Cooperative, Inc.	John Shaver	Negative	SUPPORTS THIRD PARTY COMMENTS - (ACES)
1	Sunflower Electric Power Corporation	Noman Lee Williams	Negative	SUPPORTS THIRD PARTY COMMENTS - (ACES)
1	Tampa Electric Co.	Beth Young		

1	Tennessee Valley Authority	Howell D Scott	Abstain	
1	Trans Bay Cable LLC	Steven Powell		
1	Tri-State Generation & Transmission Association, Inc.	Tracy Sliman	Affirmative	
1	Tucson Electric Power Co.	John Tolo		
1	U.S. Bureau of Reclamation	Richard T Jackson		
1	United Illuminating Co.	Jonathan Appelbaum	Affirmative	
1	Vermont Electric Power Company, Inc.	Kim Moulton		
1	Westar Energy	Allen Klassen	Negative	SUPPORTS THIRD PARTY COMMENTS - (SPP Standards Group)
1	Western Area Power Administration	Lloyd A Linke	Affirmative	
1	Wolverine Power Supply Coop., Inc.	Michelle Clements		
2	BC Hydro	Venkataramakrishnan Vinnakota	Negative	SUPPORTS THIRD PARTY COMMENTS - (Patricia Robertson)
2	California ISO	Rich Vine	Negative	COMMENT RECEIVED
2	Electric Reliability Council of Texas, Inc.	Cheryl Moseley	Affirmative	
2	Independent Electricity System Operator	Leonard Kula	Affirmative	
2	ISO New England, Inc.	Matthew F Goldberg	Negative	COMMENT RECEIVED
2	MISO	Marie Knox	Negative	SUPPORTS THIRD PARTY COMMENTS - (ISO/RTO SRC)
2	New York Independent System Operator	Gregory Campoli		
2	PJM Interconnection, L.L.C.	stephanie monzon	Affirmative	
2	Southwest Power Pool, Inc.	Charles H. Yeung	Abstain	
3	AEP	Michael E DeLoach	Abstain	
3	Alabama Power Company	Robert S Moore	Negative	SUPPORTS THIRD PARTY COMMENTS - (Southern Company)
3	Ameren Corp.	David J Jendras	Abstain	
3	APS	Sarah Kist	Affirmative	
3	Associated Electric Cooperative, Inc.	Todd Bennett	Negative	SUPPORTS THIRD PARTY COMMENTS - (AECI)
3	Avista Corp.	Scott J Kinney		
3	BC Hydro and Power Authority	Pat G. Harrington	Abstain	

3	Central Electric Power Cooperative	Adam M Weber	Negative	SUPPORTS THIRD PARTY COMMENTS - (AECI)
3	City of Austin dba Austin Energy	Andrew Gallo	Negative	SUPPORTS THIRD PARTY COMMENTS - (Luminant Generation Company, LLC)
3	City of Clewiston	Lynne Mila	Negative	SUPPORTS THIRD PARTY COMMENTS - (FMPA)
3	City of Farmington	Linda R Jacobson	Abstain	
3	City of Green Cove Springs	Mark Schultz	Negative	SUPPORTS THIRD PARTY COMMENTS - (FMPA)
3	City of Tallahassee	Bill R Fowler	Negative	SUPPORTS THIRD PARTY COMMENTS - (PSEG)
3	Colorado Springs Utilities	Jean Mueller	Negative	SUPPORTS THIRD PARTY COMMENTS - (Kaleb Brimhall, CSU)
3	Consolidated Edison Co. of New York	Peter T Yost	Affirmative	
3	Consumers Energy Company	Gerald G Farringer	Negative	COMMENT RECEIVED
3	Cowlitz County PUD	Russell A Noble	Affirmative	
3	CPS Energy	Jose Escamilla	Negative	SUPPORTS THIRD PARTY COMMENTS - (Glenn Pressler's comments submitted on behalf of CPS Energy)
3	Dominion Resources, Inc.	Connie B Lowe	Abstain	
3	DTE Electric	Kent Kujala	Negative	COMMENT RECEIVED
3	FirstEnergy Corp.	Cindy E Stewart	Affirmative	
3	Florida Keys Electric Cooperative	Tom B Anthony	Affirmative	
3	Florida Municipal Power Agency	Joe McKinney	Negative	COMMENT RECEIVED
3	Florida Power & Light Co.	Summer C. Esquerre		

3	Florida Power Corporation	Lee Schuster	Negative	SUPPORTS THIRD PARTY COMMENTS - (Duke Energy)
3	Georgia System Operations Corporation	Scott McGough	Affirmative	
3	Great River Energy	Brian Glover	Affirmative	
3	Hydro One Networks, Inc.	Ayesha Sabouba	Affirmative	
3	JEA	Garry Baker		
3	Kansas City Power & Light Co.	Joshua D Bach	Negative	COMMENT RECEIVED
3	Lakeland Electric	Mace D Hunter	Negative	SUPPORTS THIRD PARTY COMMENTS - (Public Service Enterprise Group)
3	Lee County Electric Cooperative	David A Hadzima		
3	Lincoln Electric System	Jason Fortik	Abstain	
3	Los Angeles Department of Water & Power	Mike Anctil		
3	Louisville Gas and Electric Co.	Charles A. Freibert		
3	Manitoba Hydro	Greg C. Parent	Affirmative	
3	MEAG Power	Roger Brand	Affirmative	
3	MidAmerican Energy Co.	Thomas C. Mielnik		
3	Modesto Irrigation District	Jack W Savage	Affirmative	
3	Muscatine Power & Water	John S Bos	Affirmative	
3	National Grid USA	Brian E Shanahan		
3	Nebraska Public Power District	Tony Eddleman	Abstain	
3	New York Power Authority	David R Rivera	Affirmative	
3	Northern Indiana Public Service Co.	Ramon J Barany	Negative	SUPPORTS THIRD PARTY COMMENTS - (See Joe O'Brien's Comments)
3	NW Electric Power Cooperative, Inc.	David McDowell	Negative	SUPPORTS THIRD PARTY COMMENTS - (AECI)
3	Ocala Utility Services	Randy Hahn	Negative	SUPPORTS THIRD PARTY COMMENTS - (FMPA)
3	Oklahoma Gas and Electric Co.	Donald Hargrove		
3	Omaha Public Power District	Blaine R. Dinwiddie	Affirmative	
3	Orlando Utilities Commission	Ballard K Mutters		
3	Owensboro Municipal Utilities	Thomas T Lyons	Affirmative	
3	Pacific Gas and Electric Company	John H Hagen	Affirmative	

3	Platte River Power Authority	Terry L Baker	Abstain	
3	PNM Resources	Michael Mertz	Abstain	
3	Portland General Electric Co.	Thomas G Ward	Affirmative	
3	Public Service Electric and Gas Co.	Jeffrey Mueller	Abstain	
3	Puget Sound Energy, Inc.	Mariah R Kennedy	Negative	COMMENT RECEIVED
3	Sacramento Municipal Utility District	James Leigh-Kendall	Affirmative	
3	Salt River Project	John T. Underhill	Affirmative	
3	Santee Cooper	James M Poston	Negative	COMMENT RECEIVED
3	Seminole Electric Cooperative, Inc.	James R Frauen	Abstain	
3	Sho-Me Power Electric Cooperative	Jeff L Neas	Negative	SUPPORTS THIRD PARTY COMMENTS - (AECI)
3	Snohomish County PUD No. 1	Mark Oens		
3	South Carolina Electric & Gas Co.	Hubert C Young		
3	Southern California Edison Company	Lujuanna Medina	Affirmative	
3	Tacoma Power	Marc Donaldson	Affirmative	
3	Tampa Electric Co.	Ronald L. Donahey		
3	Tennessee Valley Authority	Ian S Grant	Negative	SUPPORTS THIRD PARTY COMMENTS - (TVA)
3	Tri-State Generation & Transmission Association, Inc.	Janelle Marriott	Affirmative	
3	Westar Energy	Bo Jones	Negative	SUPPORTS THIRD PARTY COMMENTS - (SPP Standards Group)
3	Xcel Energy, Inc.	Michael Ibold	Abstain	
4	Alliant Energy Corp. Services, Inc.	Kenneth Goldsmith		
4	Blue Ridge Power Agency	Duane S Dahlquist	Affirmative	
4	City of Austin dba Austin Energy	Reza Ebrahimian	Negative	SUPPORTS THIRD PARTY COMMENTS - (Luminant Generation Company, LLC)
4	City Utilities of Springfield, Missouri	John Allen	Negative	SUPPORTS THIRD PARTY COMMENTS - (SPP Standards Review Group)



4	Consumers Energy Company	Tracy Goble	Negative	SUPPORTS THIRD PARTY COMMENTS - (Kurt LaFrance)
4	Cowlitz County PUD	Rick Syring	Affirmative	
4	DTE Electric	Daniel Herring	Negative	COMMENT RECEIVED
4	Florida Municipal Power Agency	Frank Gaffney	Negative	COMMENT RECEIVED
4	Georgia System Operations Corporation	Guy Andrews	Affirmative	
4	Herb Schrayshuen	Herb Schrayshuen	Affirmative	
4	Illinois Municipal Electric Agency	Bob C. Thomas	Abstain	
4	Indiana Municipal Power Agency	Jack Alvey	Negative	SUPPORTS THIRD PARTY COMMENTS - (Public Service Enterprise Group)
4	Madison Gas and Electric Co.	Joseph DePoorter		
4	Modesto Irrigation District	Spencer Tacke		
4	Ohio Edison Company	Douglas Hohlbaugh	Affirmative	
4	Public Utility District No. 1 of Snohomish County	John D Martinsen		
4	Sacramento Municipal Utility District	Mike Ramirez	Affirmative	
4	Seminole Electric Cooperative, Inc.	Steven R Wallace	Abstain	
4	South Mississippi Electric Power Association	Steve McElhane		
4	Tacoma Public Utilities	Keith Morisette	Affirmative	
4	Utility Services, Inc.	Brian Evans-Mongeon	Abstain	
5	Amerenue	Sam Dwyer	Abstain	
5	American Electric Power	Thomas Foltz	Abstain	
5	Arizona Public Service Co.	Scott Takinen	Affirmative	
5	BC Hydro and Power Authority	Clement Ma	Abstain	
5	Boise-Kuna Irrigation District/dba Lucky peak power plant project	Mike D Kukla	Negative	SUPPORTS THIRD PARTY COMMENTS - (SCL comments)
5	Bonneville Power Administration	Francis J. Halpin	Affirmative	
5	Brazos Electric Power Cooperative, Inc.	Shari Heino	Negative	SUPPORTS THIRD PARTY COMMENTS - (ACES)
5	City and County of San Francisco	Daniel Mason	Abstain	
5	City of Austin dba Austin Energy	Jeanie Doty	Negative	SUPPORTS THIRD PARTY COMMENTS - (Luminant)

				Generation Company, LLC)
5	City of Tallahassee	Karen Webb	Negative	SUPPORTS THIRD PARTY COMMENTS - (PSEG)
5	City Water, Light & Power of Springfield	Steve Rose		
5	Cleco Power	Stephanie Huffman	Negative	SUPPORTS THIRD PARTY COMMENTS - (See PSEG comments)
5	Cogentrix Energy Power Management, LLC	Mike D Hirst		
5	Colorado Springs Utilities	Kaleb Brimhall	Negative	SUPPORTS THIRD PARTY COMMENTS - (Colorado Springs Utilities)
5	Con Edison Company of New York	Brian O'Boyle	Affirmative	
5	Consumers Energy Company	David C Greyerbiehl	Negative	SUPPORTS THIRD PARTY COMMENTS - (Kurt LaFrance)
5	Cowlitz County PUD	Bob Essex	Affirmative	
5	Dairyland Power Coop.	Tommy Drea		
5	Dominion Resources, Inc.	Mike Garton	Abstain	
5	DTE Electric	Mark Stefaniak	Negative	SUPPORTS THIRD PARTY COMMENTS - (DTE Electric)
5	Duke Energy	Dale Q Goodwine	Negative	SUPPORTS THIRD PARTY COMMENTS - (Duke Energy)
5	Dynegy Inc.	Dan Roethemeyer	Negative	SUPPORTS THIRD PARTY COMMENTS - (PSEG)
5	E.ON Climate & Renewables North America, LLC	Dana Showalter		
5	Entergy Services, Inc.	Tracey Stubbs	Negative	SUPPORTS THIRD PARTY COMMENTS - (Entergy Transmission)
5	First Wind	John Robertson		
5	FirstEnergy Solutions	Kenneth Dresner	Affirmative	

5	Florida Municipal Power Agency	David Schumann	Negative	COMMENT RECEIVED
5	Great River Energy	Preston L Walsh	Affirmative	
5	Hydro-Québec Production	Roger Dufresne	Affirmative	
5	Ingleside Cogeneration LP	Michelle R DAntuono	Abstain	
5	JEA	John J Babik		
5	Kansas City Power & Light Co.	Brett Holland	Negative	COMMENT RECEIVED
5	Kissimmee Utility Authority	Mike Blough	Negative	SUPPORTS THIRD PARTY COMMENTS - (Florida Municipal Power Agency)
5	Liberty Electric Power LLC	Daniel Duff		
5	Lincoln Electric System	Dennis Florom	Abstain	
5	Los Angeles Department of Water & Power	Kenneth Silver		
5	Lower Colorado River Authority	Dixie Wells	Negative	COMMENT RECEIVED
5	Luminant Generation Company LLC	Rick Terrill	Negative	SUPPORTS THIRD PARTY COMMENTS - (Luminant Generation comments submitted by Alshare Hughes)
5	Manitoba Hydro	Chris Mazur	Affirmative	
5	Massachusetts Municipal Wholesale Electric Company	David Gordon	Abstain	
5	MEAG Power	Steven Grego	Affirmative	
5	Muscatine Power & Water	Mike Avesing	Affirmative	
5	Nebraska Public Power District	Don Schmit	Abstain	
5	New York Power Authority	Wayne Sipperly	Affirmative	
5	NextEra Energy	Allen D Schriver	Affirmative	
5	North Carolina Electric Membership Corp.	Jeffrey S Brame	Affirmative	
5	Northern Indiana Public Service Co.	Michael D Melvin	Negative	SUPPORTS THIRD PARTY COMMENTS - (See Joe O'Brien NIPSCO comments.)
5	Oglethorpe Power Corporation	Bernard Johnson	Affirmative	
5	Oklahoma Gas and Electric Co.	Henry L Staples		
5	Omaha Public Power District	Mahmood Z. Safi	Affirmative	
5	Pacific Gas and Electric Company	Alex Chua		

5	Platte River Power Authority	Christopher R Wood	Negative	SUPPORTS THIRD PARTY COMMENTS - (PSEG)
5	Portland General Electric Co.	Matt E. Jastram		
5	PPL Generation LLC	Annette M Bannon	Negative	SUPPORTS THIRD PARTY COMMENTS - (PPL NERC Registered Affiliates)
5	PSEG Fossil LLC	Tim Kucey	Abstain	
5	Public Utility District No. 1 of Lewis County	Steven Grega	Negative	SUPPORTS THIRD PARTY COMMENTS - (PSEG comments)
5	Public Utility District No. 2 of Grant County, Washington	Michiko Sell	Abstain	
5	Puget Sound Energy, Inc.	Lynda Kupfer	Negative	SUPPORTS THIRD PARTY COMMENTS - (Ewry, Eleanor)
5	Sacramento Municipal Utility District	Susan Gill-Zobitz	Affirmative	
5	Salt River Project	William Alkema	Affirmative	
5	Santee Cooper	Lewis P Pierce	Negative	COMMENT RECEIVED
5	Seattle City Light	Michael J. Haynes	Negative	SUPPORTS THIRD PARTY COMMENTS - (Haase, Seattle.)
5	Snohomish County PUD No. 1	Sam Nietfeld		
5	South Carolina Electric & Gas Co.	Edward Magic		
5	Southern California Edison Company	Denise Yaffe	Affirmative	
5	Southern Company Generation	William D Shultz	Negative	SUPPORTS THIRD PARTY COMMENTS - (Southern Company)
5	Tacoma Power	Chris Mattson	Affirmative	
5	Tampa Electric Co.	RJames Rocha	Abstain	
5	Tenaska, Inc.	Scott M. Helyer		
5	Tennessee Valley Authority	David Thompson	Negative	COMMENT RECEIVED
5	Tri-State Generation & Transmission Association, Inc.	Mark Stein	Affirmative	
5	U.S. Army Corps of Engineers	Melissa Kurtz		
5	USDI Bureau of Reclamation	Erika Doot		

5	Xcel Energy, Inc.	Mark A Castagneri	Negative	COMMENT RECEIVED
6	AEP Marketing	Edward P. Cox	Abstain	
6	Ameren Missouri	Robert Quinlivan	Abstain	
6	APS	Randy A. Young	Affirmative	
6	Associated Electric Cooperative, Inc.	Brian Ackermann	Negative	SUPPORTS THIRD PARTY COMMENTS - (AECI)
6	Bonneville Power Administration	Brenda S. Anderson	Affirmative	
6	City of Austin dba Austin Energy	Lisa Martin	Negative	SUPPORTS THIRD PARTY COMMENTS - (Luminant Generation Company, LLC)
6	Cleco Power LLC	Robert Hirschak	Negative	SUPPORTS THIRD PARTY COMMENTS - (See PSEG comments)
6	Colorado Springs Utilities	Shannon Fair	Negative	SUPPORTS THIRD PARTY COMMENTS - (Colorado Springs Utilities)
6	Con Edison Company of New York	David Balban	Affirmative	
6	Duke Energy	Greg Cecil	Negative	SUPPORTS THIRD PARTY COMMENTS - (Duke Energy)
6	FirstEnergy Solutions	Kevin Query	Affirmative	
6	Florida Municipal Power Agency	Richard L. Montgomery	Negative	COMMENT RECEIVED
6	Florida Municipal Power Pool	Thomas Washburn		
6	Florida Power & Light Co.	Silvia P Mitchell	Affirmative	
6	Great River Energy	Donna Stephenson	Affirmative	
6	Kansas City Power & Light Co.	Jessica L Klinghoffer	Negative	COMMENT RECEIVED
6	Lakeland Electric	Paul Shipps	Negative	SUPPORTS THIRD PARTY COMMENTS - (FMPPA)
6	Lincoln Electric System	Eric Ruskamp	Abstain	
6	Lower Colorado River Authority	Michael Shaw	Negative	SUPPORTS THIRD PARTY COMMENTS - (Dixie Wells)

6	Luminant Energy	Brenda Hampton	Negative	SUPPORTS THIRD PARTY COMMENTS - (Luminant Generation Company, LLC)
6	Manitoba Hydro	Blair Mukanik	Affirmative	
6	Modesto Irrigation District	James McFall	Affirmative	
6	New York Power Authority	Shivaz Chopra	Affirmative	
6	Northern Indiana Public Service Co.	Joseph O'Brien	Negative	COMMENT RECEIVED
6	Oglethorpe Power Corporation	Donna Johnson	Affirmative	
6	Oklahoma Gas and Electric Co.	Jerry Nottnagel		
6	Omaha Public Power District	Douglas Collins	Affirmative	
6	PacifiCorp	Sandra L Shaffer	Abstain	
6	Platte River Power Authority	Carol Ballantine	Abstain	
6	Portland General Electric Co.	Shawn P Davis	Affirmative	
6	Power Generation Services, Inc.	Stephen C Knapp		
6	Powerex Corp.	Gordon Dobson-Mack		
6	PPL EnergyPlus LLC	Elizabeth Davis	Negative	SUPPORTS THIRD PARTY COMMENTS - (PPL NERC Registered Affiliates)
6	PSEG Energy Resources & Trade LLC	Peter Dolan	Abstain	
6	Sacramento Municipal Utility District	Diane Enderby	Affirmative	
6	Salt River Project	William Abraham	Affirmative	
6	Santee Cooper	Michael Brown	Negative	COMMENT RECEIVED
6	Seattle City Light	Dennis Sismaet	Negative	SUPPORTS THIRD PARTY COMMENTS - (Paul Haase)
6	Seminole Electric Cooperative, Inc.	Trudy S. Novak	Abstain	
6	Snohomish County PUD No. 1	Kenn Backholm		
6	Southern California Edison Company	Joseph T Marone	Affirmative	
6	Southern Company Generation and Energy Marketing	John J. Ciza	Negative	SUPPORTS THIRD PARTY COMMENTS - (Southern Company)
6	Tacoma Public Utilities	Michael C Hill	Affirmative	
6	Tampa Electric Co.	Benjamin F Smith II		
6	Tennessee Valley Authority	Marjorie S. Parsons	Abstain	
6	Western Area Power Administration - UGP Marketing	Peter H Kinney		
7	Occidental Chemical	Venona Greaff		

8		David L Kiguel	Affirmative	
8		Roger C Zaklukiewicz	Affirmative	
8	Massachusetts Attorney General	Frederick R Plett	Affirmative	
8	Volkman Consulting, Inc.	Terry Volkman	Affirmative	
9	Commonwealth of Massachusetts Department of Public Utilities	Donald Nelson	Affirmative	
10	Florida Reliability Coordinating Council	Linda C Campbell	Affirmative	
10	Midwest Reliability Organization	Russel Mountjoy	Affirmative	
10	New York State Reliability Council	Alan Adamson	Affirmative	
10	Northeast Power Coordinating Council	Guy V. Zito	Affirmative	
10	ReliabilityFirst	Anthony E Jablonski	Affirmative	
10	SERC Reliability Corporation	Joseph W Spencer	Affirmative	
10	Southwest Power Pool RE	Bob Reynolds	Affirmative	
10	Texas Reliability Entity, Inc.	Karin Schweitzer	Affirmative	
10	Western Electricity Coordinating Council	Steven L. Rueckert	Abstain	

**Individual or group. (53 Responses)**  
**Name (33 Responses)**  
**Organization (33 Responses)**  
**Group Name (20 Responses)**  
**Lead Contact (20 Responses)**  
**Question 1 (47 Responses)**  
**Question 1 Comments (53 Responses)**  
**Question 2 (44 Responses)**  
**Question 2 Comments (53 Responses)**  
**Question 3 (44 Responses)**  
**Question 3 Comments (53 Responses)**  
**Question 4 (46 Responses)**  
**Question 4 Comments (53 Responses)**  
**Question 5 (46 Responses)**  
**Question 5 Comments (53 Responses)**  
**Question 6 (37 Responses)**  
**Question 6 Comments (53 Responses)**  
**Question 7 (40 Responses)**  
**Question 7 Comments (53 Responses)**  
**Question 8 (33 Responses)**  
**Question 8 Comments (53 Responses)**

Group
Northeast Power Coordinating Council
Guy Zito
Yes
Yes
Comments regarding requirement R1 can be found in the response to Question 8. Additionally, suggest clarifying requirement R1 by adding the wording "for all design criteria events" so as to make it read: R1. Each Planning Coordinator shall, for all design criteria events, at least once each calendar year, identify each Element in its area that meets one or more of the following criteria and provide notification to the respective Generator Owner and Transmission Owner, if any:
Yes
Comments regarding requirements R2 and R3 can be found in the response to Question 8. Splitting requirement R2 into two requirements adds clarity.
Yes
Requirement R4 continues to be a combined TO/GO requirement. For clarity, R4 should also be split into two requirements--one to address the GO obligations by applicable requirement, another to address the TO obligations by applicable requirement.
No
A CAP is developed to correct a problem after the requirements of a standard are implemented. The Implementation Plan should address meeting the obligations of the standard's requirements. The Implementation Plan would also address the annual identification of Elements. This would allow for the removal of requirements R5 and R6. Generator Owners and Transmission Owners need more time subsequent to the identification of load-responsive protective relays to perform a thorough evaluation. The requirement should provide at least 180 days to perform the evaluation. This will allow for a more complete response than can be obtained in 60 days. If the CAP is kept, the Generator or Transmission Owner should provide a copy of the initial Corrective Action Plan and status updates to the Planning Coordinator. The length of time an entity has to complete corrective actions should be specified. 180 calendar days is a realistic length of time.
No



Twelve months is not adequate to prepare for this standard as written. The Drafting Team should change the Implementation Plan to 24 months. The implementation could be improved by adding when the performance of requirement R1 is due. Is the PC supposed to complete its R1 analysis based on the effective date of the Standard 12 months after FERC approval, or 12 months after FERC approves the Standard then the PC has to complete the study for the calendar year? This can be difficult depending on when FERC approves the Standard. We suggest the revision to 24 months and stating that the PC is expected to complete the identification required by R1 in the calendar year that the requirement becomes effective. This removes the concern of what month FERC approves the Standard.

Yes

The wording of the Purpose should not have been changed. The existing wording "do not trip" is definitive; the proposed wording "...are expected to..." leaves room for questioning. If the proposed wording is kept, suggest that the Purpose read: To ensure that load-responsive protective relays are not expected to trip in response to stable power swings during non-Fault conditions. Regarding requirements R1, R2 and R3, to be consistent with the format of other NERC standards, the Criteria/Criterion listings should be made Parts of requirements R1, R2 and R3. Requirement R1 has the Planning Coordinator notifying the respective Generator Owner and Transmission Owner but a specific time period to complete the notification following the identification of an Element is not specified. This may appear as a gap in the process. The Planning Coordinator should have 30 days to notify the TO and GO. PRC-026 leaves out the use of transfer limits to correct for stable power swings. Transfer limits are an important tool for use in power system operations, and should be mentioned in a Rationale Box. Entities should not be exempted from the standard because of the linkage to Attachment A. Attachment A should not exclude Relay elements supervised by power swing blocking. Entities may install out of step blocking in order to be exempted from the standard. An entity may install Out of Step Blocking equipment without validating that it is set correctly because PRC-026 would not apply. Measure M3 is missing the word "meet". Measure M3 should read: M3. Each Generator Owner shall have dated evidence that demonstrates identification of the Element(s), if any, which meet the criterion in Requirement R3. Evidence may include, but is not limited to, the following documentation: emails, facsimiles, records, reports, transmittals, lists, or spreadsheets.

Group

Arizona Public Service Co

Janet Smith

Yes

Yes

Yes

Yes

Yes

Yes

Yes

Yes

The 30 days notification requirements for R2 and R3 is unnecessarily too stringent. We suggest 90 days.

Group

Puget Sound Energy

Eleanor Ewry

Yes

Yes

No

In general, we agree with the comments submitted by PSEG. R2 and R3 require TOs and GOs, respectively, to notify their Planning Coordinator within 30 days of identifying any Element that trips due to a power swing during a system disturbance due to the operation of load-responsive protective relays. PRC-026-1, as drafted, will have consequences with respect to an entity's implementation of a different standard: PRC-004-3 - Protection System Misoperation Identification and Correction – see <http://www.nerc.com/pa/Stand/Reliability%20Standards/PRC-004-3.pdf>. NERC has filed PRC-004-3 with FERC for approval. In summary, PRC-004-3 requires each operation of an interrupting device to be evaluated to determine whether a Misoperation occurred. If such a determination is made, the Protection System owner must investigate the occurrence and either (a) provide a declaration that a cause could not be determined or (b) if a cause is determined, develop and implement a Corrective Action Plan (CAP) or explain why corrective actions are beyond its control or would not improve reliability. PRC-004-3 does not require any action with regard to Element trips that are not Misoperations, i.e., "correct operations." We understand that a Protection System owner would need some documentation to make the distinction between a correct operation and a Misoperation. However, in order to be fully compliant with PRC-026-1 R2 and R3, every Element that trips due to the operation of a load-responsive relay must be evaluated by the entity to determine whether or not the trip was due to a power swing. As discussed on the September 18 webinar on PRC-026-1, the phrase "system Disturbance" has same meaning as the NERC Glossary term for "Disturbance." In other words, "system" is unnecessary. In addition, a "Fault" was stated to be a "Disturbance." Therefore, every operation of a load-responsive relay due to a Fault must be examined under PRC-026-1 to identify whether or not the Element tripped due to a power swing. • If an Elements trips due to a Misoperation, the Misoperation would be investigated under PRC-004-3, and if it was caused by a power swing that could easily be reported under PRC-026-1 as a result of the Protection System owner's compliance with PRC-004-3. Requiring all correct operations be affirmatively evaluated by the Element owner to determine whether they are attributable to a power swing would only "make work" for both the Element owners and their auditors, and the added effort would not improve reliability. Therefore, we propose that the scope of R2 and R3 for correct operations be reduced to a subset of events that are reported to NERC under EOP-004-2 – Event Reporting – see <http://www.nerc.com/pa/Stand/Reliability%20Standards/EOP-004-2.pdf>. For example, the Disturbances evaluated in PRC-026-1 for correct operations could be limited to some of the events and associated thresholds listed in EOP-004 - Attachment 1. We believe reasonable events would include: • Automatic firm load shedding on p. 9 • Loss of firm load (preferably limited to non-weather related load loss) on p. 10 • System separation (islanding) on p.10 • Generation loss on p.10, • Complete loss of off-site power to a nuclear plant on p. 10, and • Transmission loss on p.11. To couple the two standards together, NERC, which receives event reports under EOP-004-2, would need to notify the applicable TOs and GOs under PRC-026-1 of the time frame of each event. This would allow the Element owners to evaluate whether any Element trips that occurred during the event and which were correct operations were associated with a power swing. Without this notification, Events that happen outside of the Planning Coordinator's PC Area may not be properly identified by the affected PC. If this is not the intent of the standard, there needs to be a distinction made between whether relays should be evaluated against local disturbances (disturbances within the PC Area) and system-wide disturbances that would be communicated throughout the region.

Yes

No

It should be recognized in the requirement that the appropriate response to a trip due to a stable power swing might be to take no action. The requirement should be amended to allow the Element owner to make a declaration that corrective action would not improve BES reliability, therefore action will not be taken, consistent with PRC-004-3, R5.

Yes

Yes
No
Individual
Gul Khan
Oncor Electric Delivery LLC
Yes
Yes
Yes
Yes
Yes
Yes
Yes
Yes
No
Individual
John Seelke
Public Service Enterprise Group
Yes
No
The Planning Coordinator should be obligated in R1 to provide system impedance data as described in the Attachment B Criteria for each Element identified in R1 to the TO or GO that owns the Element. PCs maintain the models that contain this data, and having them provide it will result in consistency for relays set within the PC's area.
This question is a duplicate of the prior question. The response below answers Q3 in the unofficial comment form. R2 and R3 require TOs and GOs, respectively, to notify their Planning Coordinator within 30 days of identifying any Element that trips due to a power swing during a system disturbance due to the operation of load-responsive protective relays. PRC-026-1, as drafted, will have consequences with respect to an entity's implementation of a different standard: PRC-004-3 - Protection System Misoperation Identification and Correction – see <a href="http://www.nerc.com/pa/Stand/Reliability%20Standards/PRC-004-3.pdf">http://www.nerc.com/pa/Stand/Reliability%20Standards/PRC-004-3.pdf</a> . NERC has filed PRC-004-3 with FEREC for approval. In summary, PRC-004-3 requires each operation of an interrupting device to be evaluated to determine whether a Misoperation occurred. If such a determination is made, the Protection System owner must investigate the occurrence and either (a) provide a declaration that a cause could not be determined or (b) if a cause is determined, develop and implement a Corrective Action Plan (CAP) or explain why corrective actions are beyond its control or would not improve reliability. PRC-004-3 does not require any action with regard to Element trips that are not Misoperations, i.e., "correct operations." We understand that a Protection System owner would need some documentation to make the distinction between a correct operation and a Misoperation. However, in order to be fully compliant with PRC-026-1 R2 and R3, every Element that trips due to the operation of a load-responsive relay must be evaluated by the entity to determine whether or not the trip was due to a power swing. As discussed on the September 18 webinar on PRC-026-1, the phrase "system Disturbance" has same meaning as the NERC Glossary term for "Disturbance."

In other words, "system" is unnecessary. In addition, a "Fault" was stated to be a "Disturbance." Therefore, every operation of a load-responsive relay due to a Fault must be examined under PRC-026-1 to identify whether or not the Element tripped due to a power swing. • If an Elements trips due to a Misoperation, the Misoperation would be investigated under PRC-004-3, and if it was caused by a power swing that could easily be reported under PRC-026-1 as a result of the Protection System owner's compliance with PRC-004-3. Requiring all correct operations be affirmatively evaluated by the Element owner to determine whether they are attributable to a power swing would only "make work" for both the Element owners and their auditors, and the added effort would not improve reliability. Therefore, we propose that the scope of R2 and R3 for correct operations be reduced to a subset of events that are reported to NERC under EOP-004-2 – Event Reporting – see <http://www.nerc.com/pa/Stand/Reliability%20Standards/EOP-004-2.pdf> . For example, the Disturbances evaluated in PRC-026-1 for correct operations could be limited to some of the events and associated thresholds listed in EOP-004 - Attachment 1. We believe reasonable events would include: • Automatic firm load shedding on p. 9 • Loss of firm load (preferably limited to non-weather related load loss) on p. 10 • System separation (islanding) on p.10 • Generation loss on p.10, • Complete loss of off-site power to a nuclear plant on p. 10, and • Transmission loss on p.11 To couple the two standards together, NERC, which receives event reports under EOP-004-2, would need to notify the applicable TOs and GOs under PRC-026-1 of the time frame of each event. This would allow the Element owners to evaluate whether any Element trips that occurred during the event and which were correct operations were associated with a power swing.

Yes

No

The requirement to develop a CAP in R5 should be amended to allow the Element owner, in lieu of a developing a CAP, to make a declaration that corrective actions would not improve BES reliability and therefore will not be taken. This is consistent with PRC-004-3, R5.

Yes

No

Individual

Oliver Burke

Entergy Services, Inc.

Yes

Yes

Yes

Yes

Yes

Yes

Yes

Yes

Based on the information contained in the SPCS Power Swing Report Dated August 2013, there is insufficient evidence in the historical study case identified, to warrant implementation of the proposed PRC-026-1 standard.

Individual
Thomas Foltz
American Electric Power
Yes
Yes
Yes
Yes
Yes
Yes
No
Individual
Maryclaire Yatsko
Seminole Electric Cooperative, Inc.
Yes
No
Requirements R2 and R3 appear to require the reporting of trips due to UNSTABLE power swings. Seminole feels that a better mechanism for collecting information on unstable power swings is through NERC Section 1600 data requests, not via a Standard. Requirements R2 and R3 utilize the term "identifying." Can the SDT add language in the application guidelines that clarifies that "identifying" means "making a determination," as the term identifying is somewhat unclear to Seminole.
No
Requirement R5 requires the development of a CAP. Seminole requests that the ability to submit a notification to the Entity's RRO, stating why a CAP cannot or should not be implemented, be added to R5. Seminole reasons that there may be instances where a CAP is not possible, somewhat akin to a TFE in the CIP-world. The SDT could make the CAP exception contingent on the RRO's approval.
Individual
Kayleigh Wilkerson
Lincoln Electric System

Yes
Although aware of the forces driving the development of PRC-026-1, LES cannot support the standard. LES agrees with the statement in the NERC System Protection and Control Subcommittee's technical report titled "Protection System Response to Power Swings" that recommends against this standard. Reliability Standards PRC-023-3 and PRC-025-1 adequately ensure that load-responsive protective relays will not trip in response to stable power swings during non-Fault conditions. Additionally, as stated in this same report, consideration should be given to potential adverse impacts to Bulk Power System reliability as a result of the standard.
Individual
Mark Wilson
Independent Electricity System Operator
Yes
Yes
Yes
Yes
No
The scope of the proposed standard is directed at blocking the trip for stable power swings only. However, since existing distance schemes have the ability to trip for both stable and unstable swings, the standard can be interpreted as permitting a Transmission Owner to remove both trip abilities in order to comply with this standard. Removing the trip abilities for unstable power swings may have unintended consequences, such as preventing successful self-generating islands to form, making the restoration process much more difficult. In order to prevent any unintended consequence, we suggest that Requirement 5 is modified to have the Transmission Owner consult with the Planning Coordinator for whether out-of-step protection is needed, and if so, whether out of step tripping or power swing blocking should be applied: R5. Each Generator Owner and Transmission Owner shall, within 60 calendar days of an evaluation that identifies load-responsive protective relays that do not meet the PRC-026-1 – Attachment B Criteria pursuant to Requirement R4, develop a Corrective Action Plan (CAP) to modify the Protection System to meet the PRC-026-1 – Attachment B Criteria while maintaining dependable fault detection and dependable out-of-step tripping. (Each Generator Owner and Transmission Owner shall consult with their applicable Planning Coordinator if out of-step tripping should be applied at the terminal of the Element).
Yes
Yes
Individual
Amy Casuscelli
Xcel Energy
Yes
No
Criteria 1 uses the term "operating limit" and Criteria 2 uses the term "System Operating Limit;" although both are identified by the existence of angular stability constraints, thus seemingly defining the same type of operating constraint, i.e. operating limit. Xcel Energy would suggest either explaining the difference between the terms "operating limit" and "System Operating Limit", or eliminating the potentially duplicative criterion, since a "Generator" can be an "Element". In our

opinion, Requirement R1 is organized and written in a manner that makes interpretation difficult. Xcel Energy suggests that the drafting team consider re-organizing this requirement as suggested below. R1 could be split so that R1 requires the PC to perform the following at least once per year; R1.1 would require the PC to identify Elements meeting the bulleted list of criteria; R1.2 would require notification to the respective Generator Owner and Transmission owner of each Element identified in R1.1. Regardless of whether this Requirement R1 is re-organized as suggested above or not, we suggest the following rewrite of of Criteria 1 to minimize ambiguity. Criteria 1 can be split either at the "or" (as in "...addressed by an operating limit or a Remedial Action Scheme (RAS) and those Elements...") or at the "and" (as in "...addressed by an operating limit or a Remedial Action Scheme (RAS) and those Elements..."). To provide additional clarity, Criteria 1 could be rewritten as: "Generator(s) and Elements Terminating at associated transmission stations where angular stability constraint exists that is addressed by an operating limit or a Remedial Action Scheme (RAS)." These potential modifications would improve the readability of the requirement and provide for easier alignment with the associated Measures and VSLs. In addition, M1 could be rephrased to state "Each Planning Coordinator shall have dated evidence that demonstrates identification of Elements meeting the R1 criteria was performed on a calendar year basis and dated evidence that demonstrates the respective owners of the identified Elements were notified on a calendar year basis". The existing M1 phrasing of "identification and respective notification of the Elements" reads as if the Elements are being notified rather than the owners of the Elements.

No

The Measures M2 & M3 do not match the R2 & R3 requirements. The measures only require that the TO and GO have evidence of the identification of elements, but do not require evidence of notification of identified Elements to the PC. The VSLs for R2 & R3 classify it as a Severe VSL if the TO or GO fails to identify an Element in accordance with R2 & R3. However, the way R2 & R3 are written, there is no requirement for the TO or GO to identify anything. As the requirements are currently written, the only requirement is that the PC is notified within 30 calendar days of identification of an Element meeting the criteria. If a TO or GO does not identify an Element, they can never be in violation of R2 or R3 as written. Further, if there is no requirement for identification of Elements meeting R2 or R3 criteria, it is not clear what the starting point is for determining the 30 day notification period. How is the official date of identification of an Element pursuant to R2 & R3 determined? And how is it officially documented for use in establishing PC notification due date in determining the severity of the violation? It is unclear what action the PC is going to take, upon notification of the identification of an Element meeting R2 & R3 criteria, beyond adding the Element to the R1 list for future years that will be provided to the TO and GO. If that is the only resulting action, the 30 day notification of the PC or the <10 day overdue Lower VSL, <20 day overdue Moderate VSL, <30 day overdue High VSL or >30 day overdue Severe VSL do not seem to align. R4 directs the TO and GO to analyze the Elements within 12 calendar months of identifying the Element pursuant to R2 or R3. If the only action taken by the PC is to add the Element to the R1 list for future years, is would seem to be just as effective from a reliability perspective to give the TO and GO up to the next calendar year to notify the PC about R2 7 R3 identified elements and to align the R2 & R3 VSL notification timeframes with those allowed for the PC to TO/GO notifications in R1.

No

We are generally supportive of the revisions to R4 but offer the following observation. We believe that the way R4 is currently written, an Entity would be allowed to not evaluate an Element's load responsive relays if they had been evaluated in the past three calendar years even if the Element was identified within the last 12 calendar months per R2 or R3 to have tripped in response to a stable power swing. For example, if an element tripped in January 2015 due to a stable power swing, the R4 analysis is performed and corrective action taken per R5 and R6. If the device trips again in 2016 due to a stable power swing, it would appear that there was a problem with the 2015 analysis. But the way R4 is written, the entity would be exempt from performing any analysis or taking any further action until 2018. We do not believe this is the drafting team's intent.

Yes

The VSLs for R4 and R5 seem inconsistent. Entities are given 12 calendar months to perform an analysis with VSLs of increasing severity for being <30, <60, <90, and > 90 days past due. They are given 60 days to develop a CAP following completion of an evaluation that determines the need for a protection system modification to meet PRC-026-1 Attachment B criteria, and with an R5 VSL of increasing severity for being <10, <20, <30 or >30 days past due in the development of a CAP.

Given the 12 month leeway on the completion of analysis following identification of the Element and the only 60 day leeway on CAP development, why would an entity sign off an R4 analysis as complete for an element requiring a protection system modification prior to the 12 month deadline, essentially starting the 60 day clock on the CAP development R5 requirement? We recommend that all R4 analysis completion and R5 CAP development timeframes be based on the calendar months from the original date of identification of the susceptible Element and that the same <30 day, <60 day, <90 day and >90 day increments be used both R4 and R5 VSLs. This approach would eliminate any potential benefit from delaying the officially acknowledged date of completion of the R4 analysis and not have any effect on the final R5 max CAP development timeframe (ie. months since initial Element identification) allowable by the standard.

No

In the Application Guidelines, Criteria 1 uses the term "operating limit" and Criteria 2 uses the term "System Operating Limit" although both are identified by the existence of angular stability constraints, seemingly defining the same type of operating constraint, i.e. operating limit. Xcel Energy would suggest either explaining the difference between the terms "operating limit" and "System Operating Limit", or eliminating the potentially duplicative criterion, since a "Generator" can be an "Element". The lens calculation tool is not validated or authorized for use. Due to the hypothetical nature of the calculations, a standardized tool should be provided so that industry can achieve consistent results. There is no requirement that the TO provide the System Equivalent to the GO. This Standard should provide communication requirements between the GO and TO, similar to the MOD series standards effective in 2014. While this may not be necessary due to the typically amenable working relationships in a vertically integrated utility, it may be required in areas that are served by several companies.

Yes

We believe there is insufficient technical basis to make this a viable standard for industry to properly apply, and provide the following comments for consideration: We concur with the NERC concern noted in #133 of FERC order 733 that careful study and analysis of the relationship between stable power swings and protective relays is needed and consultation with IEEE and other organizations should be completed before developing a Reliability Standard addressing stable power swings. The need basis for this standard is 2003 blackout event data. Since that time, many improvements to protection systems have occurred, voltage control and frequency control requirements have either been implemented, are on a staged implementation plan, or are planned in the immediate future. The need basis data set has changed and should be based on current information, rather than past uncontrolled system reliability program data. Many improvements over the last 11 years have changed the probability of this particular need occurring, including: • Use of Generator AVR and PSS systems • Improved facility equipment ratings • Automatic voltage and frequency ride-through standards for wind turbines • Coordinated protection system settings amongst all players • Better system modeling and transmission planning These concerns would be addressed by a carefully planned study as described. We are aware of FERC's concerns around undesirable operations due to stable power swings, per Orders 733, 733A and 733B. The directive in #150 states "...we direct the ERO to develop a Reliability Standard that requires the use of protective relay systems that can differentiate between faults and stable power swings and, when necessary, phases out protective relay systems that cannot meet this requirement." We are also aware that this requirement was reinforced on September 4th, in the applicable FERC staff meeting. Due to the real or perceived urgency in completing this standard, we have offered some proposed wording intended to expedite the acceptance of the regulation. As written, we believe this draft holds potential opportunities for improvements towards readability and cohesiveness.

Individual

Alshare Hughes

Luminant Generation Company, LLC

Yes

No

Requirement R1 provides additional clarity of which Elements (including transformers, generators) are included in a notification by the Transmission Planner. In light of the fact that the purpose of this



standard is "To ensure that load-responsive protective relays are expected to not trip in response to stable power swings during non-Fault conditions" which is in agreement with the FERC Order 733 (Section 150 of the FERC Order: "requires the use of protective relay systems that can differentiate between faults and stable power swings and, when necessary, phases out protective relay systems that cannot meet this requirement"), it is an unnecessary extension of the Order to include unstable power swings. The Standard Drafting Team stated "The phrase "stable or unstable" was inserted to clarify that both are applicable to power swings because the goal of the standard is to identify Elements susceptible to either" overreaches the FERC Order. Luminant recommends that unstable power swings be removed. Additionally, R1 should be modified so that notifications are not required for elements and relays that were previously identified and are currently in a Corrective Action Plan. The Planning Assessment referenced in R1, Criteria 4 should be limited to the contingencies in TPL-001-0.1 "Table 1 Transmission System Standards – Normal and Emergency Conditions" Category A, B, C and D to focus the power swing evaluations and corrective action development on activities that support the reliability of the BES.

Yes

No

Luminant agrees that Criteria A (Attachment B) provides a method for determining a relay setting to minimize unnecessary trips due to a stable power swing; however, Luminant recommends that the generation application section include an out-of-step relay example for stable power swings. Luminant also recommends removal of unstable power swings from the requirement based on the same comments in question 2.

Yes

No

Luminant recommends that in the Generator Application section, an example of a generator out-of-step relay application for stable power swings should be provided.

Yes

No

Individual

Barbara Kedrowski

Wisconsin Electric

Yes

Yes

No

: We take issue with this requirement. First, it will be difficult or impossible for the Generator Owner (GO) to comply with. The requirement in R3 is to notify the Planning Coordinator of an Element that trips due to a stable or unstable power swing during an actual system Disturbance due to the operation of its load-responsive protective relays. Without dynamic disturbance recording (DDR), it may not be possible to determine that the relay tripped due to a power swing. The GO is not required to have (DDR) capability for every generator. Note that DDR will only be required by the future PRC-002 standard for a subset of generators, not all of them. The most that a GO may be able to do is to say that a generator relay may have operated for a power swing, especially when the Generator Owner does not own or operate the connected transmission system. Second, if an unstable power swing passes through the generator or generator step-up transformer, the generator SHOULD trip in order to prevent or limit possible damage. The generator out-of-step relay is used for this purpose, and it does not appear that this standard will allow the necessary settings on the Device 78 element to properly protect the generator. Common industry settings for the 78 out-of-step function do not appear to be possible based on the Application Guidelines in the draft standard. For these reasons, we believe that this requirement should be removed. If it is retained, then the

scope of the applicability to generators should be limited to those generators where DDR will be required per the future PRC-002.
No
The limitations imposed in the Application Guidelines will not allow a Generator Owner to set an out-of-step relay to properly protect the generator, using commonly applied settings such as for single blinder schemes, and possibly other out-of-step schemes. The settings must be able to detect a power swing in the generator or GSU transformer, which appears to violate the setting limits as in the example of Figure 20.
No
Similar to PRC-004-3 R5, the entity should be allowed to explain in a declaration why corrective actions would not improve BES reliability and that no further corrective actions will be taken. For overall BES reliability, It must be left to the equipment Owners to determine when relay settings which do not meet the Application Guidelines must still be used for proper equipment protection.
No
For generators, the Application Guidelines make reference to using the generator transient reactance $X'd$ . However, Tables 15 and 16 show the sub-transient reactance $X''d$ in the calculations. This appears to be a discrepancy. See also Question 3 above.
Group
Southern Company: Southern Company Services, Inc.; Alabama Power Company; Georgia Power Company; Gulf Power Company; Mississippi Power Company; Southern Company Generation; Southern Company Generation and Energy Marketing
Wayne Johnson
Yes
Simplifying the requirement to a single entity clarified the responsibilities.
Yes
Simplifying the requirement to a single entity clarified the responsibilities.
Yes
Since the criteria is not completely the same for the TO and GO, splitting the previous R2 into a new R2 and new R3 was a good move.
No
Is the Criteria a single page (page 17) or is it pages 17-73? The text in the rationale should be included in the Criteria paragraph so that there is no doubt what the evaluation is supposed to demonstrate. The previous draft (R3) presentation of the demonstration, CAP development, and PC/TP/RC communication was easier to understand just what was expected of the GO and TO.
No
Already discuss in Q4 comment - the requirement to develop a CAP was clear either way. The addition of the 60 day due date added more detail.
No
The calculations, requiring the extent of material provided in the application guide to explain, appear to be quite complex and difficult. Is the SDT open to considering an alternative method of evaluation? It is proposed that GO or TO give relay settings to the entity with the transient analysis modeling tool (TP/PC), and that entity determine if the GO/TO relay settings need to be modified based on the power swing characteristics and simulation results for the area being reviewed.
Yes
Yes
Comments for Application Guidelines 1. Page 1 – “The development of this standard implements the majority of the approaches suggested by the report.” 2. Page 6 – “The standard does not included any requirement for the entities to provide information that is already being shared or exchanged between entities for operating needs.” 3. Page 8 – “In order to establish a time delay that strikes a

line between a high-risk..." What is meant by "strikes"? 4. Page 8 – "For a relay impedance characteristic that has the swing entering and leaving beginning at 90 degrees with a termination at 120 degrees before exiting the zone..." "Add degrees" 5. Page 9 – Title of "Application to Transmission Elements", should be "Application Specific to Criteria A". 6. Page 9 – reference Fig 13 and 14 when discussing "infeed effect" 7. Figure 3 – Update text box "Constant Angle...Boundary (120 degrees)". 8. Table 2 through 7 – Do not need to calculate each point, does not provide added value to the document. 9. There are many tables and figures not referenced in the written portion of the document which makes the guideline difficult to read and follow. This is the case for Figure 13, 14, 15, and almost all the tables.

Individual

Bill Fowler

City of Tallahassee

Yes

No

The Planning Coordinator should be obligated in R1 to provide system impedance data as described in the Attachment B Criteria for each Element identified in R1 to the TO or GO that owns the Element. PCs maintain the models that contain this data, and having them provide it will result in consistency for relays set within the PC's area.

No

R2 and R3 require TOs and GOs, respectively, to notify their Planning Coordinator within 30 days of identifying any Element that trips due to a power swing during a system disturbance due to the operation of load-responsive protective relays. PRC-026-1, as drafted, will have consequences with respect to an entity's implementation of a different standard: PRC-004-3 - Protection System Misoperation Identification and Correction – see <http://www.nerc.com/pa/Stand/Reliability%20Standards/PRC-004-3.pdf>. NERC has filed PRC-004-3 with FERC for approval. In summary, PRC-004-3 requires each operation of an interrupting device to be evaluated to determine whether a Misoperation occurred. If such a determination is made, the Protection System owner must investigate the occurrence and either (a) provide a declaration that a cause could not be determined or (b) if a cause is determined, develop and implement a Corrective Action Plan (CAP) or explain why corrective actions are beyond its control or would not improve reliability. PRC-004-3 does not require any action with regard to Element trips that are not Misoperations, i.e., "correct operations." We understand that a Protection System owner would need some documentation to make the distinction between a correct operation and a Misoperation. However, in order to be fully compliant with PRC-026-1 R2 and R3, every Element that trips due to the operation of a load-responsive relay must be evaluated by the entity to determine whether or not the trip was due to a power swing. As discussed on the September 18 webinar on PRC-026-1, the phrase "system Disturbance" has same meaning as the NERC Glossary term for "Disturbance." In other words, "system" is unnecessary. In addition, a "Fault" was stated to be a "Disturbance." Therefore, every operation of a load-responsive relay due to a Fault must be examined under PRC-026-1 to identify whether or not the Element tripped due to a power swing. • If an Elements trips due to a Misoperation, the Misoperation would be investigated under PRC-004-3, and if it was caused by a power swing that could easily be reported under PRC-026-1 as a result of the Protection System owner's compliance with PRC-004-3. Requiring all correct operations be affirmatively evaluated by the Element owner to determine whether they are attributable to a power swing would only "make work" for both the Element owners and their auditors, and the added effort would not improve reliability. Therefore, we propose that the scope of R2 and R3 for correct operations be reduced to a subset of events that are reported to NERC under EOP-004-2 – Event Reporting – see <http://www.nerc.com/pa/Stand/Reliability%20Standards/EOP-004-2.pdf>. For example, the Disturbances evaluated in PRC-026-1 for correct operations could be limited to some of the events and associated thresholds listed in EOP-004 - Attachment 1. We believe reasonable events would include: • Automatic firm load shedding on p. 9 • Loss of firm load (preferably limited to non-weather related load loss) on p. 10 • System separation (islanding) on p.10 • Generation loss on p.10, • Complete loss of off-site power to a nuclear plant on p. 10, and • Transmission loss on p.11. To couple the two standards together, NERC, which receives event reports under EOP-004-2, would need to notify the applicable TOs and GOs under PRC-026-1 of the time frame of each event. This

would allow the Element owners to evaluate whether any Element trips that occurred during the event and which were correct operations were associated with a power swing.
Yes
No
The requirement to develop a CAP in R5 should be amended to allow the Element owner, in lieu of a developing a CAP, to make a declaration that corrective actions would not improve BES reliability and therefore will not be taken. This is consistent with PRC-004-3, R5
Yes
This standard will cause a large increase in workload for entities with a small trade off of system reliability.
Group
Associated Electric Cooperative, Inc. - JRO00088
Phil Hart
Yes
AECI agrees with SPP Comments
No
AECI agrees with SPP Comments
No
AECI agrees with SPP Comments
No
AECI agrees with SPP Comments
No
AECI agrees with SPP Comments
AECI agrees with SPP Comments
Individual
Jonathan Meyer
Idaho Power
Yes
Yes
Yes
Yes
Yes
Yes
Yes
Yes
The 30 day time requirement for notification of swing tripping events in R2 and R3 seems a little short. I think 45 to 60 days would be more appropriate.

Individual
John Pearson/Matt Goldberg
ISO New England
No
While we agree with the removal of the Reliability Coordinator and Transmission Planner, we don't believe that entities should be exempted from the standard by the linkage to Attachment A. Attachment A excludes Relay elements supervised by power swing blocking. An entity could just install Out of Step Blocking equipment with nothing to ensure that it is set correctly and the standard would not apply through the exclusion in Attachment A.
No
R1 should be changed to read: R1. Each Planning Coordinator shall, for all design criteria events at least once each calendar year, identify each Element in its area that meets one or more of the following criteria and provide notification to the respective Generator Owner and Transmission Owner, if any:
No
Although splitting the requirement into two adds clarity, what was the underlying uncertainty that this is intended to address? R4 continues to be a combined TO/GO requirement that was not split. We ask whether the same uncertainty exists for R4 (previously R3) and should it also be split?
Yes
No
For R5, Generator and Transmission Owners need more time develop a Corrective Action Plan. The requirement should provide at least 180 days to develop the Corrective Action Plan. This will allow for a more complete and thoughtful response than can be obtained in 60 days. Also under R5, the Generator or Transmission Owner should provide a copy of the initial Corrective Action Plan and status updates to the Planning Coordinator. Right now, the requirement is open ended without the provision of Corrective Action Plan information.
Yes
No
Twelve months is not adequate to prepare for this standard as written. The drafting team should change the implementation plan to twenty four months.
Yes
PRC-026 leaves out the use of transfer limits to correct for stable power swings. Transfer limits are an important tool for use in power system operations. Furthermore, Attachment A should not exclude Relay elements supervised by power swing blocking. Entities might simply install out of step blocking in order to be effectively exempted from the standard. An entity could just install Out of Step Blocking equipment with nothing to ensure that it is set correctly and the standard would not apply through the exclusion in Attachment A. This will not improve power system reliability.
Group
Colorado Springs Utilities
Kaleb Brimhall
Yes
No Comments
No
We agree with the Public Service Electric and Gas Company comments. Additional Comments: 1.) Please define a "transmission switching station," is that the same thing as a sub-station? 2.) Please clarify "angular" stability limit versus just a stability limit. 3.) How are people modeling the relay settings for R1.4? Our facility ratings take into account relay setting limitations and the facility ratings are used in the models. Is that sufficient modeling or is there some specific modeling expected for R1.4?
No

We agree with the Public Service Electric and Gas Company comments.
Yes
No
We agree with the Public Service Electric and Gas Company comments.
No Comments
Yes
No
Individual
Chris Scanlon
Exelon Companies
In the guidelines and technical basis section of the standard, a method for evaluating whether a distance element is susceptible or not is given. In the previous guidelines and technical basis, a simpler method of plotting the relay characteristic within the lens drawn at the 120 degree critical angle was also described. This method seems to have been removed from the current draft standard. This method works often for our protection schemes and requires no calculations (it is simpler and less work). The drafting team should consider putting this section back in the guidelines section to show that this method may also be used.
We agree with the drafting teams' decision that only those elements that trip in less than 15 cycles need to be evaluated for susceptibility to tripping during stable power swings. This follows from actual event experience that shows that the vast majority of relays that trip during power swings are zone 1s.
Individual
Brett Holland
Kansas City Power & Light
Yes
No
A yearly notification is too often for this requirement since this information will rarely change. We suggest a yearly notification for any change from the previous year, with a five year notification of all identified Elements.
No
A trip during a stable power swing is a mis-operation and is covered in PRC-004. A trip during an unstable power swing is an intended result and not applicable to this standard. We suggest removing these two requirements.
No
Attachment A includes Out-of-step tripping. This condition is an unstable power swing and should not be included in the standard. The standard should allow protection relays and philosophies to protect the equipment first and foremost. The requirement not to trip during a stable power swing should be reviewed and considered, but not mandatory if deemed that protection will be sacrificed.
No
Out-of-step tripping and tripping for unstable power swings are intended results. Corrective Action Plans are not needed for these events.

No
The graphs seem not to match the calculations.
Yes
No
Group
Duke Energy
Colby Bellville
Yes
Yes
Yes
Yes
Yes
Duke Energy agrees that this an improvement from the previous draft. However, we seek guidance or clarification on the boundaries between PRC-026-1 and PRC-004-3. When Misoperations occur due to a stable power swing, a CAP is required to be developed pursuant to R5 of PRC-004-3. Would the evaluation and, if needed, Corrective Action Plan from PRC-026-1 R4 through R6 be acceptable as use for the CAP required in PRC-004-3 R5?
Yes
Duke Energy agrees in part with the revisions made by the SDT on this project. However, due to the amount of technical information provided in the Application and Guidelines portion of this standard, more time is needed for our SME(s) to thoroughly review this section before submitting an "Affirmative" vote.
Individual
David Thorne
Pepco Holdings Inc.
Yes
Yes
No
The 30 day time line provided for Requirement R2 in the standard to determine if an element operated due to either of the Criteria provided seems aggressive. The shortest amount of time we have to determine if a protective relaying scheme mis-operated under current quarterly reporting requirements for PRC-004 is 60 days. It would make sense if the timeline for this standard was adjusted to match. In addition, the requirement as written does not seem to differentiate if this level of analysis is required for the operation of all in-scope protective relaying schemes or just those that were determined to mis-operated. Requiring this level of study for all in-scope protective relaying schemes would seem to provide a tremendous compliance burden to the Transmission Owners.
Yes
The requirement as written in the latest draft version of the standard is clear on what actions must be taken. The 12 month timeline is reasonable.
Yes

The requirement as written in the latest draft version of the standard is clear on what actions must be taken. The 12 month timeline is reasonable.
Yes
Yes
The 36 month time line is sufficient
No
Individual
Glenn Pressler
CPS Energy
Yes
No
In general, support Luminant comments.
No
In general, support PSEG comments.
No
In general, support Luminant comments.
No
In general, support PSEG comments.
No
In general, support Luminant comments.
Yes
No
Group
ISO RTO Council Standards Review Committee
Greg Campoli
Yes
The Standards Review Committee (SRC) agrees with the removal of the Reliability Coordinator and Transmission Planner; however, there remains concern that that entities could be exempted from the standard by the linkage to Attachment A as it excludes Relay elements supervised by power swing blocking. The SRC, therefore, recommends that the SDT assure all Applicability is explicit in the Applicability Section of the standard and that exemptions or other criteria are not embedded in Attachment A. (note CAISO does not support the response to Question 1)
Yes
The SRC agrees that the revisions improved the clarity of Requirement R1. However, to ensure consistency with the other requirements within the Standard, the SDT recommends that Requirement R1 also be broken into two (2) requirements, one addressing identification and one addressing notification. Additionally, Requirement R1 should be changed to read: R1. Each Planning Coordinator shall, for all design criteria events at least once each calendar year, identify each Element in its area that meets one or more of the following criteria and provide notification to the respective Generator Owner and Transmission Owner, if any: Finally, the SRC recommends the following revision to Criterion 1 of Requirement R1 to streamline and ensure that the focus remains on Remedial Action Schemes: 1. Generator(s) where an angular stability constraint exists that is addressed by a Remedial Action Scheme (RAS) and those Elements terminating at the transmission switching station associated with the generator(s).
No



The SRC notes that Requirements R2 and R3 are about notification if an element meeting specified criteria is identified. However, the measures are primarily focused on identification. Accordingly, the measures should be revised for consistency with the associated Requirements R2 and R3.

Yes

The SRC agrees that the revisions have provided clarity; however, notes the inconsistency within the standard regarding describing GO and TO requirements separately in Requirements R2 and R3.

No

We agree with consolidating the Corrective Action Plan obligations into Requirements R5 and R6. However, the SRC recommends that, for R5, Generator and Transmission Owners need more time to develop a thorough CAP that addresses identified issues with load-responsive protective relays. The requirement should provide at least 180 days to develop the Corrective Action Plan, which would allow for a more complete and thoughtful response than can be obtained in 60 days. Also under R5, the Generator or Transmission Owner should provide a copy of the initial Corrective Action Plan and status updates to the Planning Coordinator. Right now, the requirement is open ended without the provision of Corrective Action Plan information.

No

The SRC notes that twelve (12) months is not adequate to prepare for this standard as written. Accordingly, it is recommended that the drafting team revise the implementation plan to allow twenty four months for implementation.

Yes

The SRC respectfully submits that the Purpose statement is unclear and inconsistent with the requirements in the standard. More specifically, the requirements often refer to stable and unstable power swings, but such are not addressed in the Purpose statement. This should be clarified. The following revision is proposed. To protect against tripping by load-responsive protective relays in response to stable and unstable power swings during non-Fault conditions. The SRC has concerns with potential inconsistency between the Purpose statement and the time horizons. Specifically, Requirements R2 and R3 have a time horizon defined as Long Term Planning while the Purpose of the standard is about expected / forecasted responses. However, the verbiage of Requirements R2 and R3 requires action by the responsible entities within 30 days, which implies that the Time Horizon should be, at most, the Operations Planning time frame. The SRC requests that the SDT to review these requirements to assure they are consistent with the purpose of the standard, the Time Horizons and any changes necessary to the Applicability section.

Group

Dominion

Connie Lowe

Yes

Yes

No

M3 seems to be missing the word 'meet'; suggest M3 read as; M3. Each Generator Owner shall have dated evidence that demonstrates identification of the Element(s), if any, which 'meet' the criterion in Requirement R3. Evidence may include, but is not limited to, the following documentation: emails, facsimiles, records, reports, transmittals, lists, or spreadsheets. Dominion agrees with the split of R2, however, elements could have their load-responsive protective relays operate prior to the formation of an island. In the Application Guide, a section should be included to better define methods used for boundary detection, if we are required to determine if the element was in-fact the boundary to an island. Otherwise, power swings could cause relays to operate without internal detection algorithms picking up the swing.

Yes

No

No date is given for CAP implementation. Is it acceptable to work the CAP in with projects regardless of project execution date? (3-7 years, if no project is in place at the specific location; is it acceptable to implement the CAP once a project arises?)

No

Under Criterion R4, 'Exclusion of Time Based Load-Responsive Protective Relays,' the calculations here are ambiguous. PRC-026-1 Attachment A explicitly states we are to evaluate protective functions listed with a delay of 15 cycles or less; however, there is small section outlining the need to calculate what sort of delays should be evaluated under different slip frequencies. Adding the 'Exclusion of Time Based Load-Responsive Protective Relays' section is counter-productive in its current context. Dominion suggests that the SDT revise the section to make it more understandable or remove it. No section discusses slip frequencies ranges. The WECC experiences 0.25-0.28 Hz north-south oscillations, ERCOT experiences 0.6 Hz north-south and 0.3 Hz east-west, Tennessee to Maine experiences 0.2 Hz oscillations, but Tennessee to Missouri experiences 0.7 Hz oscillations. Roughly 0.01 to 0.8 Hz oscillations are associated with wide area oscillations, but 3.0 to 10 Hz oscillations are associated with FACTS devices that may cause wide or local. What is the acceptable range of oscillations this standard is meant to cover?

Yes

If R4 is a precursor for R5 and R6, R4-R6 should be included in the 36 month implementation plan.

Yes

No part of the standard discusses reasonable slip frequencies that should be used to detect power swings. If we identify a relay that is susceptible to tripping for stable power swings (based on the mho impedance characteristic overlapping a portion of the lens), apply a form of power swing blocking, and then the relay operates again for a different frequency. Are we to go off the most recent analysis? Slip frequency is an integral part to power swing detection and determination between a swing and loading can be difficult. There should be some discussion about this topic in conjunction with loading. Should a section discuss the correlation with PRC-023-2 requirement R2? PRC-023-2 R2. Each Transmission Owner, Generator Owner, and Distribution Provider shall set its out-of-step blocking elements to allow tripping of phase protective relays for faults that occur during the loading conditions used to verify transmission line relay loadability per Requirement R1.

Group

JEA

Tom McElhinney

Yes

Yes

Yes

Yes

No

This standard is not necessary and we agree with the analysis of the NERC SPCS that it may have unintended consequences which could decrease the reliability of the BES.

Group

PPL NERC Registered Affiliates

Brent Ingebrigtsen

These comments are submitted on behalf of the following PPL NERC Registered Affiliates: LG&E and KU Energy, LLC; PPL Electric Utilities Corporation, PPL EnergyPlus, LLC; PPL Generation, LLC; PPL Susquehanna, LLC; and PPL Montana, LLC. The PPL NERC Registered Affiliates are registered in six

regions (MRO, NPCC, RFC, SERC, SPP, and WECC) for one or more of the following NERC functions: BA, DP, GO, GOP, IA, LSE, PA, PSE, RP, TO, TOP, TP, and TSP.
No
The process of PCs annually performing an analysis and notifying TO/GOs of applicable Elements per R1, and of TO/GOs then evaluating these Elements per R4, should be clarified to note that where relays meeting criteria 1-3 of R1 are on the PC's list year after year a new evaluation is not required each time unless conditions have materially changed (threshold TBD by the SDT).
No
R4 should state that the 12-month clock for GOs begins when the TO provides the system impedance data necessary to perform studies, if the GO requests this information from the TO. Also, the reference to, "full calendar months," in R4 and Att. B should be changed to just, "calendar months," to prevent confusion.
No
: The deadline of 60 calendar days for development of a Corrective Action Plan should be changed to six months. Many GOs do not have Protection System design expertise, and the process of making a business case for the expenditure of hiring a contractor, getting this request approved, exploring alternatives, making a technical selection and again obtaining management approval can take far more than sixty days.
Individual
Jamison Cawley
Nebraska Public Power District (NPPD)
Yes
No
The PSRPS Recommendations Section states that the SPCS determined a Reliability Standard is not needed.
No
Both R2 and R3 requirements appear to take a "wait and see" approach rather than a proactive approach. This doesn't seem practical when maintaining the reliable operation of the BES. We recommend elimination of both R2 and R3. Additionally, R2 states that the TO would need to identify "an Element that forms the boundary of an island during an actual system Disturbance due to the operation of its load-responsive protective relays." This type of event would be very complex and would likely include many contingencies. Thus the statement seems too general and all-encompassing. We feel this reliability function might be better served by the Planning Coordinator(s) or Reliability Entity facilitating an event analysis where better decisions and recommendations can be made, given their wide-area view and awareness of reliability issues. If a relay did trip on OOS for a stable power swing, the likelihood of it being part of a larger event or a misoperation is high. If it were a misoperation, it would then be addressed in another standard or event analysis process. As noted above it seems R2 and R3 are better served by existing processes or standards.
Yes
Yes
We agree that separation of the CAP requirement is an improvement; however, we feel there should be a caveat to this requirement. The standard as written could result in reduced sensitivity of fault detection settings, which would interfere with "maintaining dependable fault detection". We believe there should be an option to maintain our ability to operate the BES in a reliable manner and still remain in compliance with R5. This requirement seems like double-jeopardy.
Yes

Yes
Yes
We are curious why the PC is allowed 1 year to identify elements while the industry is allowed 30 days after a disturbance to identify elements. This does not seem practical in comparison with the timelines used with other reporting requirements. For example, PRC-004 has quarterly submissions with 2 additional months after the quarter end; the new PRC-004-3 allows 120 days just to identify if an operation was a misoperation, root cause determination is not included in that timeframe. In fact, PRC-004-3 includes no set timeline to determine cause, simply a requirement to actively investigate by indicating active investigation every two calendar quarters until a cause is determined or no cause can be found. An out-of-step analysis is more complex, so it would be logical to allow longer time horizons for this type of investigation and identification, perhaps no less than an annual interval which would match the PC. Additional clarification on two items is requested: 1) If a relay has out of step tripping and blocking enabled, does this mean it is excluded from the standard? 2) If a relay has out of step blocking enabled, does this mean it is excluded from the standard? In addition to these comments, we support the comments provided by SPP.
Individual
John Merrell
Tacoma Power
Yes
Yes
Yes
Yes
Yes
No
In the Application Guidelines, in the discussion of Figure 11, suggest changing "...thus allowing the zone 2 element to meet PRC-026-1 – Attachment B, Criteria A" to something like the following: "...thus allowing the zone 2 element to meet PRC-026-1 – Attachment B, Criterion A. However, including the transfer impedance in the calculation of the lens characteristic is not compliant with Requirement R4." Similarly, update the Figure 11 caption to indicate that the calculation is not compliant with Requirement R4. In the Application Guidelines, in the discussion of Requirement R5, the statement "that all actions associated with any Corrective Action Plan (CAP) developed in the previous requirement [Requirement R4]..." is incorrect. Requirement R4 does not have anything to do with a CAP.
Yes
Yes
For Requirement R2, consider defining 'island' or adding a footnote clarifying the intent of the word. This requirement should not apply to portions of the system containing both generation and load that become isolated from the BES but that are not intended to operate apart from the BES. For example, perhaps there are parallel lines that interconnect one or more remote generation plants and some load to the rest of the system. It is doubtful that the drafting team intended to include these types of scenarios as 'islands'. Should POTT and DCB schemes be specifically called out in Attachment A as being applicable to PRC-026-1? Attachment B Criterion B may yield current that is above the phase time overcurrent pickup but, at this level of current, the phase time overcurrent element may take longer than 15 cycles to operate. Therefore, the approach in Attachment B Criterion B is potentially conservative. The Response to Issues and Directives still mentions that

"...the proposed standard does require that an Element that was part of a boundary that formed an island since January 1, 2003 be identified as an that is within the scope of the proposed standard."

Individual

David Jendras

Ameren

Yes

Yes

No

Ameren adopts the following comment submitted by PSEG. R2 and R3 require TOs and GOs, respectively, to notify their Planning Coordinator within 30 days of identifying any Element that trips due to a power swing during a system disturbance due to the operation of load-responsive protective relays. PRC-026-1, as drafted, will have consequences with respect to an entity's implementation of a different standard: PRC-004-3 - Protection System Misoperation Identification and Correction – see <http://www.nerc.com/pa/Stand/Reliability%20Standards/PRC-004-3.pdf>. NERC has filed PRC-004-3 with FERC for approval. In summary, PRC-004-3 requires each operation of an interrupting device to be evaluated to determine whether a Misoperation occurred. If such a determination is made, the Protection System owner must investigate the occurrence and either (a) provide a declaration that a cause could not be determined or (b) if a cause is determined, develop and implement a Corrective Action Plan (CAP) or explain why corrective actions are beyond its control or would not improve reliability. PRC-004-3 does not require any action with regard to Element trips that are not Misoperations, i.e., "correct operations." We understand that a Protection System owner would need some documentation to make the distinction between a correct operation and a Misoperation. However, in order to be fully compliant with PRC-026-1 R2 and R3, every Element that trips due to the operation of a load-responsive relay must be evaluated by the entity to determine whether or not the trip was due to a power swing. As discussed on the September 18 webinar on PRC-026-1, the phrase "system Disturbance" has same meaning as the NERC Glossary term for "Disturbance." In other words, "system" is unnecessary. In addition, a "Fault" was stated to be a "Disturbance." Therefore, every operation of a load-responsive relay due to a Fault must be examined under PRC-026-1 to identify whether or not the Element tripped due to a power swing. • If an Elements trips due to a Misoperation, the Misoperation would be investigated under PRC-004-3, and if it was caused by a power swing that could easily be reported under PRC-026-1 as a result of the Protection System owner's compliance with PRC-004-3. Requiring all correct operations be affirmatively evaluated by the Element owner to determine whether they are attributable to a power swing would only "make work" for both the Element owners and their auditors, and the added effort would not improve reliability. Therefore, we propose that the scope of R2 and R3 for correct operations be reduced to a subset of events that are reported to NERC under EOP-004-2 – Event Reporting – see <http://www.nerc.com/pa/Stand/Reliability%20Standards/EOP-004-2.pdf>. For example, the Disturbances evaluated in PRC-026-1 for correct operations could be limited to some of the events and associated thresholds listed in EOP-004 - Attachment 1. We believe reasonable events would include: • Automatic firm load shedding on p. 9 • Loss of firm load (preferably limited to non-weather related load loss) on p. 10 • System separation (islanding) on p.10 • Generation loss on p.10, • Complete loss of off-site power to a nuclear plant on p. 10, and • Transmission loss on p.11. To couple the two standards together, NERC, which receives event reports under EOP-004-2, would need to notify the applicable TOs and GOs under PRC-026-1 of the time frame of each event. This would allow the Element owners to evaluate whether any Element trips that occurred during the event and which were correct operations were associated with a power swing.

Yes

No

Ameren adopts the following comment submitted by PSEG. The requirement to develop a CAP in R5 should be amended to allow the Element owner, in lieu of a developing a CAP, to make a declaration that corrective actions would not improve BES reliability and therefore will not be taken. This is consistent with PRC-004-3, R5.

Yes
Yes
Yes
We appreciate the SDT's significant improvements in this draft 2. Our response to question 3 above captures our primary reason for voting negative.
Individual
Joe O'Brien
NIPSCO
No
We would prefer that the 12 month implementation plan for R1-R3, R5, R6 be set to 24 months; this is based on the related burden of implementing PRC-025-1.
Individual
Michael Moltane
ITC
Yes
Yes
Yes
Yes
Yes
No
A "no CAP declaration" should be added to R5. This option is necessary when enabling power swing blocking affects the BES reliability. An example is for a Slow Trip – During Fault, in which the high-speed protection scheme has been identified to meet the dynamic stability performance requirements of the TPL standards. As ITC stated in Draft 1, we are concerned about load/swings with subsequent phase faults which result in time-delayed tripping when power swing blocking is enabled.
No
The R2 example of an island forming is insufficient. Suppose a line includes tapped load and a tapped generator, does this form an island if the line ends trip for a phase fault? R2 Criteria 2 does not exclude this example, therefore it should be discussed in Application Guidelines and Technical Basis.
Yes
Yes
In R2, add reference to Attachment A when describing the load-responsive protective relays. R2 Criteria 2 adds no value and should be removed. All Elements which trip due to swings will be captured under Criteria 1. Criteria 2 only includes islands formed due to phase faults and adds no value. If you intend to capture boundaries of all islands formed, then remove the "due to the

operation of its load-responsive protective relays" qualifier. If you intend to capture boundaries of all islands formed due to protective relay operations, then remove the "load-responsive" qualifier. Application Guidelines, page 63, Application to Generation Elements, change the language to include generator relays, if they are set based on equipment permissible overload capability. "Load-responsive protective relays such as time over-current, voltage controlled time-overcurrent or voltage-restrained time-overcurrent relays are excluded from this standard [if] they are set based on equipment permissible overload capability." Application Guidelines, page 72, the first paragraph under Requirement R5 is more appropriate under Requirement R6.

Individual

Karin Schweitzer

Texas Reliability Entity

No

Texas Reliability Entity, Inc. (Texas RE) has concerns regarding the removal of the Reliability Coordinator (RC) from the applicability, particularly for Criteria 1 and 2 of R1. The time horizons that the Planning Coordinator (PC) and RC evaluate are different, with the Planning horizon being > 1 year and the Operations horizon being real-time to < 1 year. When the SDT removed the RC from the applicability, the Operations Planning time horizon was also removed; however, there is still language within Criteria 1 and 2 of R1 addressing angular stability constraints as monitored as part of a System Operating Limit identified in operating studies. Operating studies are not typically conducted by the PC but are conducted by the RC. Based on the language in the Criteria, it is unclear to Texas RE whether the intent of the standard is to only identify elements at risk in the Long-term Planning horizon or to identify elements at risk in both the Operations horizon and the Long-term Planning horizon. Texas RE requests clarification on this issue from the SDT. Please also see our comments to Questions 2 and 3 regarding time horizon concerns.

Yes

While Texas RE agrees with the approach of using criteria from the PSRPS technical document, we have concerns about the stated time horizon. Requirement R1 Criterion 2 states that the PC should include elements identified in operating studies, but the time horizon for this requirement is Long-term Planning. Texas RE suggests that either the Operations Planning time horizon needs to be added to this requirement or the reference to operating studies needs to be removed, whichever is in line with the intent of the SDT.

Yes

While Texas RE agrees with splitting the previous Requirement R2 into Requirement R2 for the Transmission Owner (TO) and Requirement R3 for the Generator Owner (GO) for clarity, we have concerns regarding the stated time horizon. Requirement R2 states that the TO shall notify the PC within 30 calendar days of elements that trip due to an actual disturbance, but the time horizon for this requirement is Long-term Planning (which is a planning horizon of one year or longer.) Texas RE suggests that the time horizon should be Operations Planning. Requirement R3 states that the GO shall notify the PC within 30 calendar days of elements that trip due to an actual disturbance, but the time horizon for this requirement is Long-term Planning (which is a planning horizon of one year or longer.) Texas RE suggests that the time horizon should be Operations Planning.

Yes

No comments.

Yes

No comments.

Yes

No comments.

Yes

No comments.

Yes

Texas RE suggests that the PRC-026-1 SDT refer this standard to the Project 2014-01 SDT (if not done already) for consideration regarding the applicability of BES generators to include dispersed generation resources so the requirements of the standard pertain primarily to the point of connection where the resources aggregate to 75 MVA or more, and not to the individual resources.

Since this is a new standard it is not currently included in "Appendix B: List of Standards Recommended for Further Review" from the draft white paper entitled "Proposed Revisions to the Applicability of NERC Reliability Standards NERC Standards Applicability to Dispersed Generation Resources."
Group
Florida Municipal Power Agency
Carol Chinn
No
FMPA is comfortable with the removal of the Reliability Coordinator and Transmission Planner, subject to comments we are making on R2, R3 and in response to question 8.
Yes
No
Requirements R2 and R3 need further clarification. FMPA agrees that splitting the Requirement was beneficial. However, FMPA finds the following issues left requiring resolution, which point to the need to better coordinate this standard with PRC-004: 1. The language is crafted as if a typical TO or GO would easily be able to determine that an element tripped due to a power swing. This only makes sense for large vertically integrated utilities in which staff with a variety of knowledge bases and skill sets may be working together. In reality, for smaller utilities that may be only a TO/DP or GO, this determination will require some involvement from a TP, PC, TOP, or RC, with staff that have a) access to real time information, event records, and other information beyond what any single TO or GO may have and b) an understanding of the expected regional stability performance which TO/GO staff may not have. Realistically it should only be presumed the TO or GO staff will be able to conclude that their relays did not trip for a fault. 2. The standard sets a 30 day clock which starts with a piece of information that isn't required or driven from anywhere – namely, the point in time at which at TO or GO discovers that any relay operated (either correctly or incorrectly) due to a power swing. Since there is currently no place where it is required that correct/proper relay operation be documented, it is not clear what sort of documentation the TO/GO will have and what process, performed by what staff, would drive the TO/GO to "initially discover" that the relay operated due to a power swing. The point being- in a normal PRC-004 investigation, at such time as it is discovered that a relay properly operated, there is no requirement for any formal report, on any formal schedule, to include that information. At what point does the "official" starting point of this 30 day clock occur? This points to the need for further/better coordination with PRC-004.
No
See comments in response to Question 8 related to Applicability and responsibility for various requirements.
No
FMPA agrees with the separation of R5 and R6. However, R5 pre-supposes and furthermore directs that the only acceptable Corrective Action Plan is one which involves modifying the Protection System. There are a number of other ways to improve stability performance which are therefore ruled out. In fact, improving the performance to, and reducing the severity of power swings that result from a given event should be a preferential solution as it has a much wider impact on the stability and the reliability of the system. It may be true that modifications to microprocessor relay settings or even replacement of relays might be the least cost or the fastest and simplest solution, that in no way should dictate that the standard should mandate this be the only corrective action employed.
No
FMPA commends the drafting team on the amount of material that has been developed to support the Application of this standard. The various examples used in the Application Guide are generally good example scenarios. However, the focus of the Guide seems to be more on repetitive demonstration of basic equations and less on the SDT's expected interpretation of various scenarios. One full sample of all the calculations in one scenario is all that is required. Each time the equations are repeated it takes roughly 11 pages. In general there are a lot of pages of basic equations and very little "guidance" within the examples. Furthermore, the examples seem to have been developed to make a supporting case for the Criteria of Attachment B but there is no true discussion of how



these examples should be interpreted to support the Criteria. An easy example of this is Table 10, where the impact of the system transfer impedance on the lens characteristic is tabulated, but there is no use of that data to explain why all transfer impedances, no matter what the magnitude, should be completely ignored. The data is there, but the expectations regarding interpretation of the data are more important, and these are missing. A couple of additional issues that FMPA believes should be cleaned up. • The first full paragraph of Page 28 of the Application Guidelines describes the modeling of generator reactances in stability models, but there is no segue regarding why this information was presented. Please clarify that the intent of the paragraph is to make it clear that the reactances that are used by TP's/PCs (unsaturated reactances) may not be the same reactances as the ones that are being recommended for use in the application of the criteria (saturated reactances). • The Application Guide makes frequent reference to "pilot zone 2 element" in the figures. Strictly speaking the figures show an example of a "distance" or "impedance" mho relay characteristic curve. The term "pilot" refers colloquially in protection to a communication assisted scheme, which may be used in conjunction with a mho characteristic or may not. The use of this term introduces confusion because Attachment A specifically excludes "pilot wire relays", which are a specific sub-set of transmission relay that does not use a mho characteristic.

No

The Implementation Plan does not offer compelling evidence that the implementation date for R5 and R6, which are driven exclusively by R4, should be set at 12 months from approval while R4 is at 36 months from approval. Setting R5 and R6 earlier than R4 instead of allowing them to be parallel to R4 introduces circuitous logic as now the language of these Requirements appears to require R4 to be completed early...There does not appear to be any value in setting R5 and R6 at 12 months when there is nothing to measure compliance with them against – the implementation plan explains the 12 months to is to allow entities to develop "internal processes and procedures", but the Requirements do not require such procedures nor are these listed in the measures.

FMPA would like to commend the SDT for developing an overall process that is generally reasonable and does not, in our opinion, add an excessive compliance burden, since the number of identified circuits and generators should be small. However, we believe more work is required to make the concept the SDT has come up with successful. 1. First, as mentioned in earlier sections, the standard is in general written with the perspective of large vertically integrated utilities in mind, and does not consider the impact on non-vertically integrated TOs and GOs. As such, we believe there is further coordination that needs to be developed between this standard and PRC-004, that will a) facilitate communication between PCs, TPs, TOPs, the RC, and respective investigating TOs and GOs and b) will establish a clear timeline that can cleanly be audited for R2 and R3. As stated in our comments above on R2, the requirements for keeping records for "correct" relay operations are effectively non-existent in current standards. FMPA believes it makes sense for all "investigations" and associated records to occur within PRC-004 and then for "power swing" related activities to occur in PRC-026. Currently power swings are only discussed in PRC-004 as they relate to failure to trip or slow trip conditions (and not where operation for a power swing was correct). Furthermore there is presently no acknowledgment that GOs and TOs may need assistance and information from their TPs, PCs, associated TOP, or even RC. 2. The Applicability section refers to GO's and TO's that apply load responsive relays to Generators, Transformers, and Transmission Lines. FMPA sees three issues related to this. a. First, all language in the standard Requirements refers to Elements instead of Facilities – based on previous comments and the SDT's response to those comments, the standard Requirements should be referring to Facilities to draw focus to the BES distinction, which does not exist for Elements. b. Second, the identification of issues and tracking of issues from entity to entity is based on Elements. This works from the perspective of identification of risks to the system but falls short when it comes time to evaluate and modify the Protection Systems, because no Requirement refers back to the Owner of the Protection Systems applied on the Elements identified in R1. Instead, Requirements 2 and 3 are directed at the Owner of the Element itself which may or may not own the Protection System that is actually at risk of operating (or misoperating). The Requirements need to consider this relationship similar to PRC-004-3. c. Third, it is quite possible for protective relays applied on a substation bus section or on FACTS devices to be susceptible to power swings, and in fact, in cases of intentional system separation schemes, this may be an intentional design (e.g splitting a substation bus when one or a group of transmission lines exceed a measured condition). The Facilities section does not include such Elements. 3. FMPA is concerned the conditions under which Criteria A is being calculated may be excessively conservative. Item 3 of the

Criteria states "Saturated (transient or sub-transient) reactance is used for all machines." Note the term "all", which could be confusing if an entity is not considering the context. The documentation presented does not discuss terms such as "maximum generation dispatch" or any other term that would relate back to a realistic number of generators being in service. The requirement should be "all machines that are in service in short circuit model", and in the Application Guide there should be some discussion on using maximum reasonable generation dispatches in short circuit cases. Similarly, but of less consequence, it is not clear that the Transfer Impedance should always be completely neglected. While this is certainly numerically convenient, FMPA wonders if this does not produce overly conservative results in cases of well-networked transmission. Would it not be more prudent to remove other transmission circuits which have significant transfer distribution factors relative to the line in question, and then re-calculate the transfer impedance, rather than assuming some exceedingly large number of transmission outages has occurred? This relates to the comment above that some discussion should be offered surrounding Table 10 in the Application Guide. 4. As written, the combination of Requirement R4 (which instructs the TO/GO to "evaluate" its relays against the "Criteria" in Attachment B) and the Criteria in Attachment B, make no definitive statements about what relays "meet" anything, or "are deficient and require corrective action plans" etc. Requirements and Criteria should be very clear and straight forward. The "Criteria" is really just a description. There is no information in the Requirement or in the Attachment that actually involves making a "judgment" which is the most important part of the definition of the term Criteria. FMPA is well aware of the intent of these two items and only wishes to point out that the intent is really only made clear in the Application Guidelines.

Group

DTE Electric Co.

Kathleen Black

Yes

Yes

Yes

No

R4 is clearer in general terms, however, the Criterion and related Guidelines and Technical Basis do not cover all the various relay scheme configurations that may apply. Since specific criteria must be evaluated, the concern is that relay scheme configurations not discussed may result in an incorrect evaluation.

Yes

No

While considerable discussion and examples have been provided, there are variations in relay types and schemes that are not specifically covered. Perhaps these variations could be submitted at some point for review and application guidance.

Yes

No comment

Yes

Will this Standard result in any conflicts with PRC-019 or PRC-025 while meeting protection goals in setting generator relays?

Individual

Muhammed Ali

Hydro One

Yes

Yes



No
Group
FirstEnergy Corp.
Richard Hoag
Yes
Yes
FirstEnergy suggests a slight modification to the wording of R1 Criteria 5 for clarity, as follows: "An Element reported by the Transmission Owner pursuant to Requirement R2 or Generator Owner pursuant to R3, unless ...".
Yes
Regarding R3, as a Generator Owner in a deregulated / competitive environment, we still have a concern about being held accountable for events for which we are unaware – power swings or Disturbances on the system (Criteria 1) – due to FERC Code of Conduct separation with the regulated system. We are not aware of system events. We realize, however, that R3 says, "... within 30 calendar days of identifying ..."; the concern simply relates to the level of responsibility placed on the GO to "identify" tripping of load-responsive relays caused by "... a stable or unstable power swing during an actual system Disturbance ...".
No
Attachment B, Criteria A and B might be clearer to a Protection Design Engineer, but are not likely clear to typical compliance personnel.
Yes
Assuming a situation results in the need for a CAP, what is the purpose of stating that dependable fault detection (and out-of-step tripping if applied) shall be maintained while developing the CAP? Maintenance and testing of protection is covered in PRC-005, and any failure of existing protection is addressed by PRC-004. Why is there further need to address maintaining existing protection, and how is such a requirement measured in the context of PRC-026-1? Also, what is the anticipated mechanism for tracking and reporting progress on a CAP?
Yes
Yes
No
Individual
Dixie Wells
Lower Colorado River Authority
Yes
Yes
Yes
The splitting of requirement for GO and TO was good. It would be more clear if R2&R3 can directly refer to the protective elements being addressed in Attachment A are the elements to look into when power swings (stable/unstable) occurs. Also, listing some particular in events that power swings would happen can be helpful.
No
see comments for R4 under application guidelines.
No

R5(part of the previously R3), missed the alternative options in previously R3 which allows entities owner to obtain agreement from planning coordinator, if a dependable fault detection or out of step tripping cannot be achieved. R5 in application guideline asks to "develop" and "complete" the CAP, while R5 in the standard only ask to "develop" within 60 cal day time period. It's ambiguous with R6 in the standard which asks to "implement" the CAP without any specific time period . And i assume this is to allow the "implementation" to be occur during next available plant outage.

No

see comments for application guidelines. It would be helpful to include out of step examples for the GO and TO.

Yes

No

Individual

Andrew Z. Pusztai

American Transmission Company, LLC

Yes

Yes

Yes

Yes

Yes

Yes

Group

Tennessee Valley Authority

Dennis Chastain

Yes

Yes

The addition of criteria 5 seems circular in that the PC is notifying the GO or TO about Elements they already know about. If the PC's analysis applying criteria 1-4 does not identify these Elements initially, why should the same PC criteria be entrusted to determine that "the Element is no longer susceptible to power swings"?

Yes

No

While an improvement over the previous draft, we believe the time interval for consideration of previous evaluations should be extended to the prior five calendar years. We also would prefer to see more flexibility in the standard to allow entities to use their preferred methods (not strictly adhering to Attachment B criteria) for determining if a line is likely to trip during a stable power swing.

Yes

Group
Santee Cooper
S. Tom Abrams
No
There seems to be some overlap between PRC-004 and R2 and R3 of this standard (PRC-026). For compliance with PRC-004, entities have to analyze all operations in order to prove that all misoperations are identified. To identify an Element that (according to R2 and R3 of PRC-026) "trips due to a stable or unstable power swing during an actual system Disturbance due to the operation of its load-responsive protective relays," a similar proof could be required, that all trips of load responsive relays were evaluated under a criteria to rule out operation due to stable or unstable power swings. The listed Rationale for R2 gives mention to the review of relay tripping is addressed in other NERC Reliability Standards, so there seems to be a nod given to PRC-004, but it should be clearer as to the interrelationship between these standards. Significant confusion could result if the interrelationship or dividing line (whichever is more appropriate) between these two standards is defined further. Will compliance with R2 and R3 of PRC-026 only involve having the data for the operations determined to be caused by power swings, or will it require data that entities provide documentation of the evaluation each operation for power swing implications?
Individual
Jason Snodgrass
Georgia Transmission Corporation
Yes
No
Recommend further clarity and a revision to R1 criteria 1 such as: From this: Generator(s) where an angular stability constraint exists that is addressed by an operating limit or a Remedial Action Scheme (RAS) and those Elements terminating at the transmission switching station associated with the generator(s). To this: Generator(s) and those interconnecting Elements terminating at the transmission switching station associated with the generator(s), where an angular stability constraint exists that is addressed by an operating limit or a Remedial Action Scheme (RAS).
Yes
Yes
Yes
Yes
Group
SPP Standards Review Group

Shannon V. Mickens
Yes
Thank you for removing the Reliability Coordinator function. The Reliability Coordinator has no place in this standard.
No
In light of the fact that the purpose of this standard is "To ensure that load-responsive protective relays are expected to not trip in response to stable power swings during non-Fault conditions" which is in agreement with the FERC Order 733 (Section 150 of the FERC Order: "requires the use of protective relay systems that can differentiate between faults and stable power swings and, when necessary, phases out protective relay systems that cannot meet this requirement"), it is an unnecessary extension of the Order to include unstable power swings. The Standard Drafting Team stated "The phrase "stable or unstable" was inserted to clarify that both are applicable to power swings because the goal of the standard is to identify Elements susceptible to either" overreaches the FERC Order. We recommend that the term 'Unstable Power Swing' be removed from the standard.
No
What is the difference between '12 full calendar months' and '12-calendar months'? Delete the 'full' in Requirement R4. In the 3rd line of Requirement R4, change 'Requirement' to 'Requirements'. Refer to our comments in Question #2 as to why we don't agree with the revisions.
No
Insert a 'to' between 'pursuant' and 'Criterion' in the 3rd line up from the bottom of the paragraph on Criterion 1. In the 9th line in the 1st paragraph under Criterion 4, capitalize 'Criterion'. In Figures 1 and 2, change 'Criterion five' to 'Criterion 5'. In the 7th line of the paragraph following Figures 1 and 2, change 'included' to 'include'. In the 8th line of the paragraph under Requirement R4, delete 'full' and hyphenate '12-calendar'. In the 5th line of the 2nd paragraph under Exclusion of Time Based Load-Responsive Protective Relays, insert 'degrees' between '120' and 'before'. In the 3rd line of the paragraph immediately following Table 1, capitalize 'Zone'. In the 15th line of the same paragraph, delete the same phrase in the parenthetical. In the 4th line of the paragraph following Equation (3), replace 'plus and minus' with '±'. Capitalize 'Zone 2' in the captions of Figures 10, 11, 12, and 15. In that same paragraph, capitalize 'Zone 2'. In the last line of the 2nd paragraph under Application to Generation Elements, replace 'Requirement' with 'Requirements'. Capitalize 'Zone 2' in the 1st line of Example R5a. Capitalize 'Zone 2' in the 1st line of Example R5c.
No
We have a concern that the Implementation Plan doesn't reflect the changes mentioned by the drafting team in their response to our comments on Question 4 in the previous posting. That response states 'The drafting team increased the Implementation Plan to three years to provide for the initial influx of identified Elements under Requirement R1. The evaluation of relays under Requirement R4 previously R3) is to be performed "within 12 full calendar months of receiving notification of an Element... where the evaluation has not been performed in the last three calendar years." Change made'. We request clarification on why this change doesn't appear in the current proposed standard and Implementation Plan.
Delete the reference to PRC-026-1 in 4.1.1 and 4.1.3 in the Applicability section. Leave the references simply as Attachment A. Delete 'This' in the 1st line of the 4th paragraph under 5. Background: . At the end of the 6th line and beginning of the 7th line in the same paragraph, delete 'of security'. Hyphenate 30-, 60-, 90-calendar days and similar construction with calendar months throughout the standard. At the end of each of the first three bullets in 1.2 Evidence Retention the phrase 'following the completion of each Requirement' appears. Since each bullet only refers to one requirement what does this phrase mean when applied to Requirements R1, R2 and R3 individually? Why is the timing for notification in the VSLs for the Transmission Owner in Requirement R2 and the Generation Owner in Requirement R3 different from that for the Planning Coordinator in Requirement R1? Shouldn't they be the same? We recommend that all changes made to the standard be reflected in the RSAW as well.
Individual

John Brockhan
CenterPoint Energy
Yes
No
CenterPoint Energy recommends additional clarification be provided for identifying and the reporting, or not reporting, of Elements that trip from power swings during system disturbances. We believe certain tripping should be excluded, such as, when reconnecting islands and during black start restoration. We suggest the following sentence be added to Requirement R1, Criterion 1: "Notification shall not be provided if an Element trips from a power swing that occurs during operator-initiated switching to reconnect islands, to restore load during Black Start activities, or to synchronize a generating unit to the system". In addition, it may be needed to clarify that tripping of Elements from voltage or frequency oscillations due to power system stabilizer issues are not to be reported.
No
CenterPoint Energy recommends that requirements for Corrective Action Plans (CAP) be removed in the draft PRC-026-1 standard. The operation of a Protection System during a non-fault condition due to a stable power swing would be a reportable Misoperation under PRC-004. Both the current enforceable version of PRC-004 and the one under development require a CAP for a Misoperation. Consistent with one of the recommendations from the NERC Industry Experts initiative, CenterPoint Energy believes that there should not be duplicative requirements in NERC Reliability Standards.
Yes
CenterPoint Energy recommends removing references to "unstable" power swings in the draft PRC-026-1 standard, as we believe tripping from unstable power swings is random and not indicative of an Element being more susceptible to a stable power swing. Where tripping actually occurs for an unstable power swing is dependent on the location and nature of the event, system conditions, and where additional Element outages occur during a disturbance. We are not aware of any available technical information or analysis to justify that an Element is more susceptible to a stable power swing if it has tripped from an unstable power swing.
Group
Seattle City Light
Paul Haase
No
Seattle City Light is not convinced that this Standard is warranted, and does not find comfort in the tortured process associated with developing the recommendations of the PSRPS document. The changes, as far as they go, do add some clarity to R1.
Yes
Yes
Seattle appreciates the effort of the drafting team to separate auditable activities into an individual requirement or subrequirement rather than blending them together.
Yes
Seattle appreciates the effort of the drafting team to separate auditable activities into an individual requirement or subrequirement rather than blending them together.
No
Seattle appreciates the efforts of the drafting team to provide application guidance and technical basis information and welcomes the trend towards such implementation documentation throughout



the standards development process. For PRC-026, this material has improved somewhat compared to the original draft, but application of the standard remains insufficiently clear for Seattle to recommend an affirmative ballot at this time. More examples and/or a flow chart or something similar to fully delineate the steps in the process are wanted.

Individual

Sergio Banuelos

Tri-State Generation and Transmission Association, Inc.

Yes

Yes

Yes

Yes

Yes

The requirement to develop a CAP in R5 should be edited to allow the owner to make a declaration that corrective actions would not improve BES reliability if that is the case and therefore action will not be taken. This is consistent with PRC-004-3, R5.

No

The "Exclusion of Time Based Load-Responsive Protective Relays" on p 25 indicates that time delayed Zone 2 and Zone 3 relays are intended to be excluded from this standard. However, many of the figures reference Zone 2 relay compliance or non-compliance; in particular, see Figure 10. That seems to imply that the Zone 2 relays in the example do need to comply with this standard. If we are told that time-delayed relay elements are to be excluded, does this imply that the Zone 2 relay is being used in a directional comparison blocking (DCB) scheme? If so, should that not be clearly identified? (Only Figures 3 and 12 identify the element in question as being a pilot Zone 2, and pilot could refer to many schemes that would not be impacted by extending beyond the defined impedance boundary). Similar to that example would be the use of Zone 2 relay elements to assert permission in a permissive overreaching transfer trip (POTT) scheme. It is likely that Zone 2 relay elements in a POTT scheme could extend beyond the impedance characteristic defined in Attachment B, but the only regions that would result in tripping in less than 15 cycles are the overlapping Zone 2 regions that result in POTT scheme activation, which would most likely be fully contained in the region defined in Attachment B. Tri-State believes that a statement or example clarifying that such a protection system is compliant would be beneficial to applicable entities as well as the compliance monitoring entities.

Yes

No

Group

ACES Standards Collaborators

Jason Marshall

Yes

(1) We largely agree with the applicability changes. We thank the drafting team for removing Transmission Planner and avoiding the confusion that has occurred in so many other standards from joint responsibility to meet the same requirements as the PC. (2) We are concerned with the removal of the RC. Per the SDT's response to our comments regarding which SOLs (planning horizon is covered FAC-010 and operating horizon is covered in FAC-011), the SDT indicated that they intended for both to apply. Since the SOL methodology that applies in the operating time horizon is written by the RC, the PC may not be familiar enough with the RC's methodology to determine which

operating horizon SOLs are due to angular stability. Wouldn't it be easier for the RC to notify the PC of those operating SOLs caused by angular stability?

No

(1) We agree that the clarity of Requirement R1 is improved but we still have a couple of concerns. (2) Why is the PC required to notify the GO and TO of Elements that were involved in actual events when the GO and TO are the entities that notify the PC in the first place? Doesn't the PC just need to notify the GO and TO when those Elements are no longer susceptible to tripping from stable power swings? (3) In Criterion 4, why are unstable power swings included? Elements should trip due to unstable power swings. Why does the GO and TO need to modify relaying for unstable power swings? Since PRC-006 only requires the PC to simulate the UFLS Program every five years, it seems that requiring the PC to identify the same Elements that form a UFLS island boundary every year is unnecessary. Criterion 3 should be modified to clarify that this notification is only necessary once every five years when the UFLS study is completed.

Yes

(1) We agree with splitting the requirements because the GO simply is not privy to the same information as the TO to identify island boundaries. However, it is reasonable for the GO to work with the TO and TOP to determine the cause of the relay operations to be from a stable power swing. (2) We believe the time horizons for both requirements R2 and R3 need to be modified. Both are currently long-term planning which is one year or longer into the future. Since this is an evaluation of actual events, we believe the Operations Assessment time horizon is more accurate. (3) Why is tripping from unstable power swings included in these two requirements? Relays should trip due to unstable power swings. The FERC directive compelled NERC to develop a standard that requires protection systems to be able to differentiate between stable power swings and faults. The directive did not require NERC to specifically address unstable powers swings. We recommend removing unstable power swings from both R2 and R3.

Yes

We agree the requirement is much clearer.

No

We agree splitting the requirement into two requirements where one deals with assessing the Protection System and the other deals with developing a CAP is an improvement. However, we continue to believe the Requirement R6 is an administrative requirement that meets P81 criteria and should be removed. The only way the R6 will ever be violated is if an entity fails to update their paperwork on the CAP. How does failing to update documentation not administrative? How does ensuring the documentation is updated by enforcing penalties serve reliability? How is this consistent with RAI which is intended to refocus compliance and enforcement on those risks most important to reliability and not on documentation issues?

No

(1) The "Application Guidelines and Technical Basis" are quite helpful and definitely do provide additional insight into the meaning of the requirements. However, we believe additional modifications are necessary. (2) On page 18 in the second paragraph, we do not believe the paragraph captures all of the reasons for changing the applicability of the standard. We believe that changing the applicability makes that standard consistent with the other relay loadability standards and makes the standard consistent with the functional model. These reasons are important to capture as they are more substantial than those listed. (3) In the Requirement R1 paragraph on page 20, please change "and other NERC Reliability Standards" to PRC-006. There are two main standards (or five depending on which version of TPL are used) that drive identification of Elements susceptible to stable power swings. They are the UFLS standards and TPL standard(s). As written, this paragraph is too open ended and could lead to confusion. (4) We suggest that a diagram should be developed depicting the example in the second paragraph on page 24. (5) In the "lens characteristic" examples, we suggest that annotating the figure with the actual lens point would be helpful in understanding the "lens characteristic".

No

We do believe the 36-month period of implementation for R4 is sufficient. However, we do not understand why R5 and R6 do not have the same effective date as R4. They are dependent on R4 with the "pursuant to Requirement R4" and "pursuant to Requirement R5" clauses in the requirements. To avoid the confusion associated with monitoring compliance to R5 and R6 when

they cannot technically be violated, please align the effective date for R5 and R6 to R4 to avoid this confusion.
Yes
(1) We believe the data retention section is inconsistent with the RAI. RAI is intended to refocus the ERO's compliance monitoring and enforcement efforts on those matters that pose the greatest risk to the reliability to the BES. This involves making compliance monitoring and enforcement forward looking to provide reasonable assurance of future compliance and reliability. How does a three-year data retention requirement support this forward looking vision of RAI? We suggest that the data retention should be no more than one year, based on the annual cycle established in this standard. (2) Why is 36 calendar months in bullet 4 instead of 3 calendar years that is used in the first three bullets? It seems they should be the same to avoid confusion. Notwithstanding our earlier comments regarding making the data retention period no longer than one year, we suggest using consistent language throughout the data retention section. Thus, use either 36 calendar months or three calendar years, but not both.
Group
Bonneville Power Administration
Andrea Jessup
Yes
Yes
BPA requests a revision to R1 to separate customer notifications from technical analysis. R1.1 Each Planning Coordinator shall, at least once each calendar year, identify each Element in its area that meets one or more of the following criteria.... R1.2 Each Planning Coordinator shall provide notification to each respective Generator Owner or Transmission Owner that owns an Element identified in R1.1.
Yes
Yes
BPA agrees that Attachment B is an improvement; however, it could be better. It appears that the only way to verify compliance is through a graphical comparison of the relay characteristic and a lens characteristic that is described in the Application Guidelines. The Application Guidelines give one example of calculating six sample points on the lens characteristic. BPA was able to work our way through the example, but it was somewhat difficult and required lots of reading between the lines. BPA requests more explicit explanations of what is expected to show compliance and how to develop the lens characteristic.
Yes
No
BPA agrees that Attachment B is an improvement; however, it could be better. It appears that the only way to verify compliance is through a graphical comparison of the relay characteristic and a lens characteristic that is described in the Application Guidelines. The Application Guidelines give one example of calculating six sample points on the lens characteristic. BPA was able to work our way through the example, but it was somewhat difficult and required lots of reading between the lines. BPA requests more explicit explanations of what is expected to show compliance and how to develop the lens characteristic.
BPA cannot estimate if the implementation plan provides sufficient time until BPA determines how many elements that R1 applies to.
Yes
BPA suggests re-ordering the requirements for continuity because the standard is working/designing the system to prevent trips by load-responsive relays unnecessarily. R1 (PC identify criteria influenced Elements ANNUALLY) R4 (GO/TO evaluate elements identified by the PC's identifier of Gen restraint, line part of SOL angular, UFLS line boundary ) R5 (GO/TO develop a CAP for at risk protection on R4 elements) R6 (GO/TO implement the CAP) R2 (TO notify PC within 30 days if an element trips by load-responsive protection due to swings or forms a boundary during a actual

system Disturbance) R3 (GO notifies PC within 30 days if element trips by load-responsive protection during a swing)

Individual

Kurt LaFrance

Consumers Energy Company

No

The Transmission Owner and Generator Owner on their own do not have the capability to determine if a trip was caused due to a swing. In most cases the Generator Owner has no knowledge of events on the transmission system, and in many cases the Transmission Owner may only own one terminal of a transmission line. Given the available data for a single terminal, there is no reliable way for an Owner to determine if a trip was due to a fault or a swing. The Transmission Planner and/or Reliability Coordinator have the broad system perspective to track how a swing moves through the transmission system and impacts each element and should determine whether any given event was involved a swing through a specific Element.

Yes

No

R2 and R3 require modification to provide clarity in how the Owner will determine if any given trip is due to a swing. Without specific guidance on how to identify and document when a swing occurs and whether that swing caused a trip, we do not believe we are able to comply with R2 or R3. For instance, if an Owner only has electromechanical relays on a terminal, and does not own the other terminal(s) of that element, how is it to determine the impedance trajectory and whether or not that trajectory was a swing or a fault?

Yes

Yes

No

The revised application guidelines are very helpful, but need to be expanded to include guidance on how to comply with R2 and R3, specifically how Generator Owners and Transmission Owners are expected to determine whether a trip was due to a swing. Given the lack of guidance we have at this point, we feel we are unable to comply with R2 or R3.

Yes

No

Individual

Richard Vine

California ISO

No

The California ISO does not agree with the change to remove the Transmission Planner in the Applicability section and in Requirement R1. The California ISO supports continuing to include the Transmission Planner in Requirement R1 as suggested by the PSRPS Report.

No

The California ISO does not agree with the change to remove the Transmission Planner in the Applicability section and in Requirement R1. The California ISO supports continuing to include the Transmission Planner in Requirement R1 as suggested by the PSRPS Report.

## Additional Comments

Oncor  
Gul Khan

2. Do you agree that the revisions to Requirement R1 improved clarity while remaining consistent with the focused approach of using the Criteria which came from recommendations in the PSRPS technical document<sup>1</sup> (pg. 21 of 61)? If not, please explain why and provide an alternative, if any.

Yes

No

Comments:

3. The previous Requirement R2 was split into Requirement R2 for the Transmission Owner and Requirement R3 for the Generator Owner in order to clarify the performance for identifying Elements that trip. Did this revision improve the understanding of what is required? If not, please explain why the Requirement(s) need additional clarification.

Yes

No

Comments:

Arizona Public Service  
Donna Turner

---

2. Do you agree that the revisions to Requirement R1 improved clarity while remaining consistent with the focused approach of using the Criteria which came from recommendations in the PSRPS technical document<sup>2</sup> (pg. 21 of 61)? If not, please explain why and provide an alternative, if any.

Yes

No

Comments:

3. The previous Requirement R2 was split into Requirement R2 for the Transmission Owner and Requirement R3 for the Generator Owner in order to clarify the performance for identifying Elements that trip. Did this revision improve the understanding of what is required? If not, please explain why the Requirement(s) need additional clarification.

Yes

No

Comments:

---

# Consideration of Comments

## Project 2010-13.3 Phase 3 of Relay Loadability: Stable Power Swings

The Project 2010-13.3 Drafting Team thanks all commenters who submitted comments on the standard. These standards were posted for a 45-day public comment period from August 22, 2014 through October 6, 2014. Stakeholders were asked to provide feedback on the standards and associated documents through a special electronic comment form. There were 53 sets of comments, including comments from approximately 147 different people from approximately 102 companies representing all 10 Industry Segments as shown in the table on the following pages.

All comments submitted may be reviewed in their original format on the standard's [project page](#).

If you feel that your comment has been overlooked, please let us know immediately. Our goal is to give every comment serious consideration in this process. If you feel there has been an error or omission, you can contact the Director of Standards, Valerie Agnew, at 404-446-2566 or at [valerie.agnew@nerc.net](mailto:valerie.agnew@nerc.net). In addition, there is a NERC Reliability Standards Appeals Process.<sup>1</sup>

## Summary of Changes to the Standard

The following is a summary of the change made to the proposed PRC-026-1 NERC Reliability Standard.

### Applicability

Section 4.2, Facilities was revised from “The following Bulk Electric System Elements” to “The following Elements that are part of the Bulk Electric System (BES)” to clarify that the listed items are the items being addressed in the Requirements as the “Elements.”

### Requirement R1

The Elements from the Applicability 4.2 (i.e., generator, transformer, and transmission line BES Elements) was added for clarity. Also, the Requirement was modified to specifically require “notification” rather than “identify and provide notification.” Identification of Elements based on the criteria is implied and necessary as a part of the Requirement.

### Requirement R1, Criterion 1

The term “operating limit” was clarified to be “System Operating Limit (SOL)” to remove ambiguity between the operating and planning time frame. Also, “transmission switching station” was revised to

---

<sup>1</sup> The appeals process is in the Standard Processes Manual: [http://www.nerc.com/comm/SC/Documents/Appendix\\_3A\\_StandardsProcessesManual.pdf](http://www.nerc.com/comm/SC/Documents/Appendix_3A_StandardsProcessesManual.pdf)

be “Transmission station.” The word “switching” did not add any additional clarity and the capitalized term “Transmission” references the *Glossary of Terms Used in NERC Reliability Standards*.

#### **Requirement R1, Criterion 2**

The phrase “constraints identified in system planning or operating studies” was modified to be “...a SOL identified by the Planning Coordinator’s methodology.” This allows the Standard to draw a connection between the FAC-010<sup>2</sup> NERC Reliability Standard applicable to the Planning Coordinator in the planning horizon.

#### **Requirement R1, Criterion 3**

This criterion originally identified Elements that formed the boundary of an island which in many cases would include Elements that were selected as arbitrary separation points and are not intended to be included within the scope of the Standard. Therefore, Criterion 3 was rewritten to reflect it is the Element which tripped on angular stability thus forming the island. Also, the criterion was updated to reflect the most recent “design assessment” by the Planning Coordinator (i.e., PRC-006) and when the Planning Coordinator uses angular stability as a design criteria for identifying islands.

#### **Requirement R1, Criterion 4**

The term “annual” was added to provide clarity.

#### **Requirement R1, Criterion 5**

Criterion 5 was removed from Requirement R1 because Requirements R2 and R3 in Draft 2 were eliminated. Those Requirements directed the Transmission Owner and Generator Owner to notify the Planning Coordinator of Elements that actually tripped due to a stable or unstable power swing. Criterion 5 created a loopback to the Generator Owner and Transmission Owner to ensure that load-responsive protective relays on identified Elements were evaluated on a periodic basis. Actual tripping events are now included in Requirement R2 (previously Requirement R4) and do not require periodic review, unless the Element trips due to a stable or unstable power swing.

#### **Measure M1**

Measure M1 was updated to reflect changes to Requirement R1 and to clarify that the focus is on notification and not identification of Elements.

#### **Requirements R2 and R3**

These Requirements were removed due to structural changes in Requirement R4 (now Requirement R2). The evaluation Requirement (now R2) was restructured to have two conditions for performance; 1) upon notification of an Element pursuant to Requirement R1, and 2) an actual event due to a stable or unstable power swing.

---

<sup>2</sup> System Operating Limits Methodology for the Planning Horizon



### **Requirement R4**

This Requirement became Requirement R2 due to the removal of Requirements R2 and R3. Most significantly, the Requirement was restructured to incorporate the removal of Requirements R2 and R3. It was determined that Elements that tripped due to a stable or unstable power swing (R2/R3) would be infrequent and more than likely a significantly large event which the Planning Coordinator would be aware of through an event analysis. The new structure of the Requirement causes an evaluation; however, it would not be necessary for the Planning Coordinator to be notified and then to continue notifying the Generator Owner and Transmission Owner. Elements that actually tripped due to stable or unstable power swings are not typical and requiring the Generator Owner and Transmission Owner to do a one-time analysis is sufficient to address the risk.

### **Requirements R5 and R6**

These Requirements became Requirements R3 and R4 due to the removal of Requirements R2 and R3. Requirement R3 to develop the Corrective Action Plan (CAP) was inflexible as it only allowed the modification of a Protection System that did not meet the PRC-026-1 – Attachment B criteria. To correct this issue, Requirement R3 was modified to meet the purpose of the standard which is to ensure that load-responsive protective relays are expected to not trip in response to stable power swings during non-Fault conditions. First, the Requirement was revised to include two conditions. The first condition requires a CAP to be developed such that the Protection System will meet the PRC-026-1 – Attachment B criteria. For example, this may include a Protection System modification or a system configuration change which causes the Protection System to meet the criteria. Second, the CAP allows power swing block to be applied such that the Protection System may be excluded from the Standard.

Also, the development period of the CAP was extended from 90 calendar days to six calendar months due to the complexities that might be involved with determining appropriate remediation of a Protection System that did not meet PRC-026-1 – Attachment B criteria.

### **Compliance Section**

Section C1.1.2 was modified to conform evidence retention to the Reliability Assurance Initiative (RAI). Retention periods were set to 12 calendar months.

### **Violation Severity Levels**

The Violation Severity Levels (VSL) were modified to align them with the revisions made to the Requirements.

### **PRC-026-1 – Attachments A and B**

Attachment A received editorial changes and Attachment B, Criteria A was rewritten to clarify that a relay characteristic that is completely contained within the unstable power swing region meets the criteria. The unstable power swing region is formed by the union of three shapes in the impedance (R-X) plane.

**Guidelines and Technical Basis**

This section was revised substantively in response to comments and due to the removal of Requirements R2 and R3. Revisions are too numerous to list here effectively. Please see the Guidelines and Technical Basis redline document for changes.

**Implementation Plan**

The period for implementing the standard did not change substantively. Based on comments, the implementation time frame for Requirements R5 and R6 (now Requirements R3 and R4) were increased from 12 calendar months to 36 calendar months to align them with Requirement R4 (now Requirement R2).

1. Do you agree with the Applicability changes to PRC-026-1 (e.g., removal of the Reliability Coordinator and Transmission Planner)? If not, please explain why an entity is not appropriate and/or suggest an alternative that should identify the Elements according to the criteria..... 17
2. Do you agree that the revisions to Requirement R1 improved clarity while remaining consistent with the focused approach of using the Criteria which came from recommendations in the PSRPS technical document (pg. 21 of 61)? If not, please explain why and provide an alternative, if any. .... 28
3. The previous Requirement R2 was split into Requirement R2 for the Transmission Owner and Requirement R3 for the Generator Owner in order to clarify the performance for identifying Elements that trip. Did this revision improve the understanding of what is required? If not, please explain why the Requirement(s) need additional clarification. .... 46
4. Requirement R4 (previously R3) contained multiple activities (e.g., demonstrate, develop a Corrective Action Plan, obtain agreement) and was ambiguous. Do you agree that the revision to Requirement R4 now provides a clearer understanding of what is required by the Generator Owner and Transmission Owner for an identified Element? Note: The Criterion is now found in PRC-026-1 – Attachment B, Criteria A and B. If not, please explain why the Requirement is not clear. .... 75
5. The new Requirement R5 (previously R4) and the new Requirement R6 address Corrective Action Plans (CAP), if any. Do you agree this is an improvement over having the development of the CAP comingled with other Requirement? If not, please explain..... 87
6. Does the “Application Guidelines and Technical Basis” provide sufficient guidance, basis for approach, and examples to support performance of the requirements? If not, please provide specific detail that would improve the Guidelines and Technical Basis. ....104
7. The Implementation Plan for the proposed standard has been revised, based on comments, to account for factors such as the initial influx of identified Elements and ongoing burden of entities to identify Elements and re-evaluate Protection Systems. Does the implementation plan provide sufficient time for implementing the standard? If not, please provide a justification for changing the proposed implementation period and for which Requirement.....119
8. If you have any other comments on PRC-026-1 that have not been stated above, please provide them here: .....127

**The Industry Segments are:**

- 1 — Transmission Owners
- 2 — RTOs, ISOs
- 3 — Load-serving Entities
- 4 — Transmission-dependent Utilities
- 5 — Electric Generators
- 6 — Electricity Brokers, Aggregators, and Marketers
- 7 — Large Electricity End Users
- 8 — Small Electricity End Users
- 9 — Federal, State, Provincial Regulatory or other Government Entities
- 10 — Regional Reliability Organizations, Regional Entities

Group/Individual		Commenter	Organization	Registered Ballot Body Segment											
				1	2	3	4	5	6	7	8	9	10		
1.	Group	Guy Zito	Northeast Power Coordinating Council												X
Additional Member		Additional Organization		Region	Segment Selection										
1.	Alan Adamson	New York State Reliability Council, LLC		NPCC	10										
2.	David Burke	Orange and Rockland Utilities Inc.		NPCC	3										
3.	Greg Campoli	New York Independent System Operator		NPCC	2										
4.	Sylvain Clermont	Hydro-Quebec TransEnergie		NPCC	1										
5.	Kelly Dash	Consolidated Edison Co. of New York, Inc.		NPCC	1										
6.	Gerry Dunbar	Northeast Power Coordinating Council		NPCC	10										
7.	Peter Yost	Consolidated Edison Co. of New York, Inc.		NPCC	3										
8.	Kathleen Goodman	ISO - New England		NPCC	2										
9.	Michael Jones	National Grid		NPCC	1										
10.	Mark Kenny	Northeast Utilities		NPCC	1										
11.	Helen Lainis	Independent Electricity System Operator		NPCC	2										
12.	Alan MacNaughton	New Brunswick Power Corporation		NPCC	9										

Group/Individual	Commenter	Organization	Registered Ballot Body Segment											
			1	2	3	4	5	6	7	8	9	10		
13. Bruce Metruck	New York Power Authority	NPCC 6												
14. Silvia Parada Mitchell	NextEra Energy, LLC	NPCC 5												
15. Lee Pedowicz	Northeast Power Coordinating Council	NPCC 10												
16. Robert Pellegrini	The United Illuminating Company	NPCC 1												
17. Si Truc Phan	Hydro-Quebec TransEnergie	NPCC 1												
18. David Ramkalawan	Ontario Power Generation, Inc.	NPCC 5												
19. Brian Robinson	Utility Services	NPCC 8												
20. Ayesha Sabouba	Hydro One Networks Inc.	NPCC 1												
21. Brian Shanahan	National Grid	NPCC 1												
22. Wayne Sipperly	New York Power Authority	NPCC 5												
23. Ben Wu	Orange and Rockland Utilities Inc.	NPCC 1												
2. Group	Janet Smith	Arizona Public Service Co	X		X		X	X						
N/A														
3. Group	Eleanor Ewry	Puget Sound Energy	X		X		X							
N/A														
4. Group	Wayne Johnson	Southern Company: Southern Company Services, Inc.; Alabama Power Company; Georgia Power Company; Gulf Power Company; Mississippi Power Company; Southern Company Generation; Southern Company Generation and Energy Marketing	X		X		X	X						
N/A														
5. Group	Phil Hart	Associated Electric Cooperative, Inc. - JRO00088	X		X		X	X						
<b>Additional Member</b>		<b>Additional Organization</b>	<b>Region</b>	<b>Segment Selection</b>										
1.	Central Electric Power Cooperative		SERC	1, 3										
2.	KAMO Electric Cooperative		SERC	1, 3										
3.	M & A Electric Power Cooperative		SERC	1, 3										
4.	Northeast Missouri Electric Power Cooperative		SERC	1, 3										

Group/Individual	Commenter	Organization	Registered Ballot Body Segment												
			1	2	3	4	5	6	7	8	9	10			
5.	N.W. Electric Power Cooperative, Inc.	SERC	1, 3												
6.	Sho-Me Power Electric Cooperative	SERC	1, 3												
6.	Group	Kaleb Brimhall	Colorado Springs Utilities	X		X		X	X						
N/A															
7.	Group	Colby Bellville	Duke Energy	X		X		X	X						
	<b>Additional Member</b>	<b>Additional Organization</b>	<b>Region</b>	<b>Segment Selection</b>											
1.	Doug Hils	Duke Energy	RFC	1											
2.	Lee Schuster	Duke Energy	FRCC	3											
3.	Dale Goodwine	Duke Energy	SERC	5											
4.	Greg Cecil	Duke Energy	RFC	6											
8.	Group	Greg Campoli	ISO RTO Council Standards Review Committee		X										
	<b>Additional Member</b>	<b>Additional Organization</b>	<b>Region</b>	<b>Segment Selection</b>											
1.	Charles Yeung	SPP	SPP	2											
2.	Ben Li	IESO	NPCC	2											
3.	Matt Goldberg	ISONE	NPCC	2											
4.	Mark Holman	PJM	RFC	2											
5.	Lori Spence	MISO	MRO	2											
6.	Cheryl Moseley	ERCOT	ERCOT	2											
7.	Ali Miremadi	CAISO	WECC	2											
9.	Group	Connie Lowe	Dominion	X		X		X	X						

Group/Individual		Commenter	Organization	Registered Ballot Body Segment									
				1	2	3	4	5	6	7	8	9	10
		<b>Additional Member</b>	<b>Additional Organization</b>	<b>Region</b>	<b>Segment Selection</b>								
1.	Larry Nash	Electric Transmission	SERC	1, 3									
2.	Mike Garton	NERC Compliance Policy	NPCC	5, 6									
3.	Louis Slade	NERC Compliance Policy	RFC	5, 6									
4.	Randi Heise	NERC Compliance Policy	SERC	1, 3, 5, 6									
5.	Christopher Mertz	Electric Transmission	SERC	1, 3									
10.	Group	Tom McElhinney	JEA	X		X		X					
		<b>Additional Member</b>	<b>Additional Organization</b>	<b>Region</b>	<b>Segment Selection</b>								
1.	Ted Hobson		FRCC	1									
2.	Garry Baker		FRCC	3									
3.	John Babik		FRCC	5									
11.	Group	Brent Ingebrigtsen	PPL NERC Registered Affiliates	X		X		X	X				
		<b>Additional Member</b>	<b>Additional Organization</b>	<b>Region</b>	<b>Segment Selection</b>								
1.	Charlie Freibert	LG&E and KU Energy, LLC	SERC	3									
2.	Annette Bannon	PPL Generation, LLC	RFC	5									
3.		PPL Susquehanna, LLC	RFC	5									
4.		PPL Montana, LLC	WECC	5									
5.	Brenda Truhe	PPL Electric Utilities Corporation	RFC	1									
6.	Elizabeth Davis	PPL EnergyPlus, LLC	MRO	6									
7.			NPCC	6									
8.			RFC	6									
9.			SERC	6									

Group/Individual	Commenter	Organization	Registered Ballot Body Segment																																																																																					
			1	2	3	4	5	6	7	8	9	10																																																																												
10.		SPP	6																																																																																					
11.		WECC	6																																																																																					
12.	Group	Carol Chinn	Florida Municipal Power Agency	X		X	X	X	X																																																																															
				<table border="1"> <thead> <tr> <th>Additional Member</th> <th>Additional Organization</th> <th>Region</th> <th>Segment Selection</th> </tr> </thead> <tbody> <tr><td>1.</td><td>Tim Beyrle</td><td>City of New Smyrna Beach</td><td>FRCC</td><td>4</td></tr> <tr><td>2.</td><td>Jim Howard</td><td>Lakeland Electric</td><td>FRCC</td><td>3</td></tr> <tr><td>3.</td><td>Greg Woessner</td><td>Kissimmee Utility Authority</td><td>FRCC</td><td>3</td></tr> <tr><td>4.</td><td>Lynne Mila</td><td>City of Clewiston</td><td>FRCC</td><td>3</td></tr> <tr><td>5.</td><td>Cairo Vanegas</td><td>Fort Pierce Utility Authority</td><td>FRCC</td><td>4</td></tr> <tr><td>6.</td><td>Randy Hahn</td><td>Ocala Utility Services</td><td>FRCC</td><td>3</td></tr> <tr><td>7.</td><td>Don Cuevas</td><td>Beaches Energy Services</td><td>FRCC</td><td>1</td></tr> <tr><td>8.</td><td>Stanley Rzad</td><td>Keys Energy Services</td><td>FRCC</td><td>4</td></tr> <tr><td>9.</td><td>Mark Schultz</td><td>City of Green Cove Springs</td><td>FRCC</td><td>3</td></tr> <tr><td>10.</td><td>Tom Reedy</td><td>Florida Municipal Power Pool</td><td>FRCC</td><td>6</td></tr> <tr><td>11.</td><td>Steven Lancaster</td><td>Beaches Energy Services</td><td>FRCC</td><td>3</td></tr> <tr><td>12.</td><td>Richard Bachmeier</td><td>Gainesville Regional Utilities</td><td>FRCC</td><td>1</td></tr> <tr><td>13.</td><td>Mike Blough</td><td>Kissimmee Utility Authority</td><td>FRCC</td><td>5</td></tr> </tbody> </table>																Additional Member	Additional Organization	Region	Segment Selection	1.	Tim Beyrle	City of New Smyrna Beach	FRCC	4	2.	Jim Howard	Lakeland Electric	FRCC	3	3.	Greg Woessner	Kissimmee Utility Authority	FRCC	3	4.	Lynne Mila	City of Clewiston	FRCC	3	5.	Cairo Vanegas	Fort Pierce Utility Authority	FRCC	4	6.	Randy Hahn	Ocala Utility Services	FRCC	3	7.	Don Cuevas	Beaches Energy Services	FRCC	1	8.	Stanley Rzad	Keys Energy Services	FRCC	4	9.	Mark Schultz	City of Green Cove Springs	FRCC	3	10.	Tom Reedy	Florida Municipal Power Pool	FRCC	6	11.	Steven Lancaster	Beaches Energy Services	FRCC	3	12.	Richard Bachmeier	Gainesville Regional Utilities	FRCC	1	13.	Mike Blough	Kissimmee Utility Authority	FRCC	5
Additional Member	Additional Organization	Region	Segment Selection																																																																																					
1.	Tim Beyrle	City of New Smyrna Beach	FRCC	4																																																																																				
2.	Jim Howard	Lakeland Electric	FRCC	3																																																																																				
3.	Greg Woessner	Kissimmee Utility Authority	FRCC	3																																																																																				
4.	Lynne Mila	City of Clewiston	FRCC	3																																																																																				
5.	Cairo Vanegas	Fort Pierce Utility Authority	FRCC	4																																																																																				
6.	Randy Hahn	Ocala Utility Services	FRCC	3																																																																																				
7.	Don Cuevas	Beaches Energy Services	FRCC	1																																																																																				
8.	Stanley Rzad	Keys Energy Services	FRCC	4																																																																																				
9.	Mark Schultz	City of Green Cove Springs	FRCC	3																																																																																				
10.	Tom Reedy	Florida Municipal Power Pool	FRCC	6																																																																																				
11.	Steven Lancaster	Beaches Energy Services	FRCC	3																																																																																				
12.	Richard Bachmeier	Gainesville Regional Utilities	FRCC	1																																																																																				
13.	Mike Blough	Kissimmee Utility Authority	FRCC	5																																																																																				
13.	Group	Kathleen Black	DTE Electric Co.			X	X	X																																																																																
				<table border="1"> <thead> <tr> <th>Additional Member</th> <th>Additional Organization</th> <th>Region</th> <th>Segment Selection</th> </tr> </thead> <tbody> <tr><td>1.</td><td>Kent Kujala</td><td>NERC Compliance</td><td>RFC</td><td>3</td></tr> <tr><td>2.</td><td>Daniel Herring</td><td>NERC Training &amp; Standards Development</td><td>RFC</td><td>4</td></tr> <tr><td>3.</td><td>Mark Stefaniak</td><td>Merchant Operations</td><td>RFC</td><td>5</td></tr> <tr><td>4.</td><td>Dave Szulczewski</td><td>DE-EE Relay Eng Supv</td><td>RFC</td><td></td></tr> </tbody> </table>																Additional Member	Additional Organization	Region	Segment Selection	1.	Kent Kujala	NERC Compliance	RFC	3	2.	Daniel Herring	NERC Training & Standards Development	RFC	4	3.	Mark Stefaniak	Merchant Operations	RFC	5	4.	Dave Szulczewski	DE-EE Relay Eng Supv	RFC																																														
Additional Member	Additional Organization	Region	Segment Selection																																																																																					
1.	Kent Kujala	NERC Compliance	RFC	3																																																																																				
2.	Daniel Herring	NERC Training & Standards Development	RFC	4																																																																																				
3.	Mark Stefaniak	Merchant Operations	RFC	5																																																																																				
4.	Dave Szulczewski	DE-EE Relay Eng Supv	RFC																																																																																					



Group/Individual	Commenter	Organization	Registered Ballot Body Segment											
			1	2	3	4	5	6	7	8	9	10		
14.	Group	Richard Hoag	FirstEnergy Corp.	X		X	X	X	X					
<b>Additional Member</b>		<b>Additional Organization</b>		<b>Region</b>	<b>Segment Selection</b>									
1.	Wiliam Smith	First Energy Corp	RFC	1										
2.	Cindy Stewart	FirstEnergycorp.com	RFC	3										
3.	Doug Hohlbaugh	Ohio Edison	RFC	4										
4.	Ken Dresner	FirstEnergy Solutions	RFC	5										
5.	Kevin Querry	FirstEnergy Solutions	RFC	6										
6.	Richard Hoag	First Energy Corp	RFC	NA										
15.	Group	Dennis Chastain	Tennessee Valley Authority	X		X		X	X					
<b>Additional Member</b>		<b>Additional Organization</b>		<b>Region</b>	<b>Segment Selection</b>									
1.	DeWayne Scott		SERC	1										
2.	Ian Grant		SERC	3										
3.	Brandy Spraker		SERC	5										
4.	Marjorie Parsons		SERC	6										
16.	Group	S. Tom Abrams	Santee Cooper	X		X		X	X					
<b>Additional Member</b>		<b>Additional Organization</b>		<b>Region</b>	<b>Segment Selection</b>									
1.	Tom Abrams	Santee Cooper	SERC	1, 3, 5, 6										
2.	Rene Free	Santee Cooper	SERC	1, 3, 5, 6										
3.	Bridget Coffman	Santee Cooper	SERC	1, 3, 5, 6										
17.	Group	Shannon V. Mickens	SPP Standards Review Group		X									
<b>Additional Member</b>		<b>Additional Organization</b>		<b>Region</b>	<b>Segment Selection</b>									

Group/Individual	Commenter	Organization	Registered Ballot Body Segment																	
			1	2	3	4	5	6	7	8	9	10								
1.	John Allen	City Utilities of Springfield	SPP	1, 4																
2.	Jamison Cawley	Nebraska Power Review Board	SPP	1, 3, 5																
3.	Michael Jacobs	Camstex	NA - Not Applicable	NA																
4.	Stephanie Johnson	Westar Energy	SPP	1, 3, 5, 6																
5.	Bo Jones	Westar Energy	SPP	1, 3, 5, 6																
6.	Tiffany Lake	Westar Energy	SPP	1, 3, 5, 6																
7.	Derek Brown	Westar Energy	SPP	1, 3, 5, 6																
8.	Lynn Schroeder	Westar Energy	SPP	1, 3, 5, 6																
9.	Charles Lee	Kansas City Power & Light	SPP	1, 3, 5, 6																
10.	Mike Kidwell	Empire District Electric	SPP	1, 3, 5																
11.	James Nail	City of Independence, MO	SPP	3, 5																
12.	Ashley Stringer	Oklahoma Municipal Power Authority	SPP	4																
13.	Jonathan Hayes	Southwest Power Pool	SPP	2																
14.	Robert Rhodes	Southwest Power Pool	SPP	2																
15.	Shannon Mickens	Southwest Power Pool	SPP	2																
18.	Group	Paul Haase	Seattle City Light		X			X	X	X	X									
				<b>Additional Member</b>	<b>Additional Organization</b>	<b>Region</b>	<b>Segment Selection</b>													
1.	Pawel Krupa	Seattle City Light	WECC	1																
2.	Dana Wheelock	Seattle City Light	WECC	3																
3.	Hao Li	Seattle City Light	WECC	4																
4.	Mike Haynes	Seattle City Light	WECC	5																
5.	Dennis Sismaet	Seattle City Light	WECC	6																
19.	Group	Jason Marshall	ACES Standards Collaborators													X				
				<b>Additional Member</b>	<b>Additional Organization</b>	<b>Region</b>	<b>Segment Selection</b>													
1.	Bob Solomon	Hoosier Energy	RFC	1																

Group/Individual	Commenter	Organization	Registered Ballot Body Segment																	
			1	2	3	4	5	6	7	8	9	10								
2.	John Shaver	Arizona Electric Power Cooperative	WECC	4, 5																
3.	John Shaver	Southwest Transmission Cooperative	WECC	1																
4.	Shari Heino	Brazos Electric Power Cooperative	ERCOT	1, 5																
5.	Kevin Lyons	Central Iowa Power Cooperative	MRO	1																
6.	Ellen Watkins	Sunflower Electric Power Cooperative	SPP	1																
7.	Ginger Mercier	Prairie Power	SERC	3																
8.	Scott Brame	North Carolina Electric Membership Corporation	SERC	3, 4, 5																
9.	Paul Jackson	Buckeye Power	RFC	3, 4, 5																
20.	Group	Andrea Jessup	Bonneville Power Administration		X			X		X	X									
		<b>Additional Member</b>	<b>Additional Organization</b>	<b>Region</b>	<b>Segment Selection</b>															
1.	Jim Burns	Technical Operations	WECC	1																
2.	Dean Bender	System Control Engineering	WECC	1																
3.	Chuck Matthews	Transmission Planning	WECC	1																
4.	Jim Gronquist	Transmission Planning	WECC	1																
21.	Individual	Gul Khan	Oncor Electric Delivery LLC		X															
22.	Individual	John Seelke	Public Service Enterprise Group		X		X		X	X										
23.	Individual	Oliver Burke	Entergy Services, Inc.		X															
24.	Individual	Thomas Foltz	American Electric Power		X		X		X	X										
25.	Individual	Maryclaire Yatsko	Seminole Electric Cooperative, Inc.		X		X	X	X	X										
26.	Individual	Kayleigh Wilkerson	Lincoln Electric System		X		X		X	X										
27.	Individual	Mark Wilson	Independent Electricity System Operator			X														
28.	Individual	Amy Casuscelli	Xcel Energy		X		X		X	X										
29.	Individual	Alshare Hughes	Luminant Generation Company, LLC						X	X	X									

Group/Individual		Commenter	Organization	Registered Ballot Body Segment										
				1	2	3	4	5	6	7	8	9	10	
30.	Individual	Barbara Kedrowski	Wisconsin Electric			X	X	X						
31.	Individual	Bill Fowler	City of Tallahassee			X								
32.	Individual	Jonathan Meyer	Idaho Power	X										
33.	Individual	John Pearson/Matt Goldberg	ISO New England		X									
34.	Individual	Chris Scanlon	Exelon Companies	X		X		X	X					
35.	Individual	Brett Holland	Kansas City Power & Light	X		X		X	X					
36.	Individual	David Thorne	Pepco Holdings Inc.	X		X								
37.	Individual	Glenn Pressler	CPS Energy	X		X		X						
38.	Individual	Jamison Cawley	Nebraska Public Power District (NPPD)	X		X		X						
39.	Individual	John Merrell	Tacoma Power	X										
40.	Individual	David Jendras	Ameren	X		X		X	X					
41.	Individual	Joe O'Brien	NIPSCO	X		X		X	X					
42.	Individual	Michael Moltane	ITC	X										
43.	Individual	Karin Schweitzer	Texas Reliability Entity											X
44.	Individual	Muhammed Ali	Hydro One	X		X								
45.	Individual	Ayesha Sabouba	Hydro One	X		X								
46.	Individual	Jo-Anne Ross	Manitoba Hydro	X		X		X	X					
47.	Individual	Dixie Wells	Lower Colorado River Authority					X						
48.	Individual	Andrew Z. Pusztai	American Transmission Company, LLC	X										
49.	Individual	Jason Snodgrass	Georgia Transmission Corporation	X										
50.	Individual	John Brockhan	CenterPoint Energy	X										
51.	Individual	Sergio Banuelos	Tri-State Generation and Transmission Association, Inc.	X		X		X						
52.	Individual	Kurt LaFrance	Consumers Energy Company			X	X	X						
53.	Individual	Richard Vine	California ISO		X									



If you support the comments submitted by another entity and would like to indicate you agree with their comments, please select "agree" below and enter the entity's name in the comment section (please provide the name of the organization, trade association, group, or committee, rather than the name of the individual submitter).

**Summary Consideration:** The drafting team appreciates entities that support the comments of others. Having single sets of comments with documented support greatly improves the efficiency of the standard drafting team. This format also ensures the drafting team has a clearer picture of the number of stakeholders supporting the same concerns or suggestions as the case may be. Please see the responses to the entity's comments that are being supported here.

Organization	Agree	Supporting Comments of "Entity Name"
Associated Electric Cooperative, Inc. - JRO00088	Yes	AECl agrees with SPP Comments <b>Response:</b> The standard drafting team thanks you for participating, please see the responses to SPP Standard Review Group.

1. **Do you agree with the Applicability changes to PRC-026-1 (e.g., removal of the Reliability Coordinator and Transmission Planner)? If not, please explain why an entity is not appropriate and/or suggest an alternative that should identify the Elements according to the criteria.**

**Summary Consideration:** About 87 percent of commenters agree with the Applicability change in Requirement R1 of the Standard to remove the Reliability Coordinator and Transmission Planner. The following summary discusses the major concerns that resulted in revisions to the Standard and one minor concern that did not result in a change to the Standard.

There were three significant themes of comments that resulted in a revision to the Standard.

First, there were five comments supported by 35 individuals (includes Questions 1-8) that were concerned that an applicable Generator Owner or Transmission Owner would be exempted from the proposed PRC-026-1 Standard if the entity applies out-step-blocking. The standard drafting team agrees and when entities implement power swing blocking (PSB) relays, do so using engineering judgment and accepted industry practices, the reliability purpose of the Standard is met. Draft 3, Requirement R3 (previously Draft 2, Requirement R5) for developing a Corrective Action Plan (CAP) clarifies this as an option to meeting the Purpose Statement of the Standard.

Second, two comments represented by 11 individuals raised questions about the use of “operating” in conjunction with the “planning” time horizon in the Requirement R1 criteria. The standard drafting team revised Requirement R1, Criterion 1 that is applicable to the Planning Coordinator to replace the phrase “an operating limit” with “System Operating Limit (SOL).” Further, the standard drafting team reworded Requirement R1, Criterion 2 to remove the phrase “identified in system planning or operating studies” and clarify that the SOL is identified based on the Planning Coordinator’s methodology in the “planning” horizon. This revision aligns the *Glossary of Terms Used in NERC Reliability Standards* defined term, “System Operating Limit” or “SOL” with its use in the Standard. Also, this revision aligns the use of “SOL” with the Planning Coordinator’s methodology of how SOLs are developed according to the NERC Reliability Standard, FAC-10 (i.e., System Operating Limits Methodology for the Planning Horizon).

Last, there were two comments supported by five individuals that commented about the overlap between the proposed PRC-026-1, Requirements R2 and R3 and NERC Reliability Standard PRC-004.<sup>3</sup> The concern stemmed from the perception of having to perform Protection System reviews in both standards. The standard drafting team addressed this concern by removing Requirements R2 and R3 (notification to the Planning Coordinator) and incorporating a revision to the Draft 3, Requirement R2 (previously Draft 2,

---

<sup>3</sup> Protection System Misoperation Identification and Correction.

Requirement R4). The revision clarified that the Generator Owner and Transmission Owner must perform an evaluation of its load-responsive protective relays according to the Requirement upon becoming aware of a stable or unstable power swing.

The following summarizes a comment that did not result in a change to the Standard. Two comments supported by nine individuals did not want the Transmission Planner removed from the applicability of the Standard. The standard drafting team removed the Transmission Planner (and Reliability Coordinator) as applicable entities in the last draft (Draft 2) of the proposed standard in response to comments to address concerns about overlap and potential gaps when identifying Elements in Requirement R1 according to the criteria. Although the PSRPS Report<sup>4</sup> suggested the Transmission Planner and Reliability Coordinator entities along with the Planning Coordinator for inclusion in the Standard’s Applicability, the standard drafting team agreed with comments received on Draft 1 that the Planning Coordinator is in the best position to identify Elements to avoid duplication and potential gaps.

Organization	Yes or No	Question 1 Comment
Florida Municipal Power Agency	No	FMPA is comfortable with the removal of the Reliability Coordinator and Transmission Planner, subject to comments we are making on R2, R3 and in response to question 8.  <b>Response:</b> Please see comments in Question 8.
Santee Cooper	No	There seems to be some overlap between PRC-004 and R2 and R3 of this standard (PRC-026). For compliance with PRC-004, entities have to analyze all operations in order to prove that all misoperations are identified. To identify an Element that (according to R2 and R3 of PRC-026) “trips due to a stable or unstable power swing during an actual system Disturbance due to the operation of its load-responsive protective relays,” a similar proof could be required, that all trips of load responsive

<sup>4</sup> NERC System Protection and Control Subcommittee, *Protection System Response to Power Swings*, August 2013: [http://www.nerc.com/comm/PC/System%20Protection%20and%20Control%20Subcommittee%20SPCS%2020/SPCS%20Power%20Swing%20Report\\_Final\\_20131015.pdf](http://www.nerc.com/comm/PC/System%20Protection%20and%20Control%20Subcommittee%20SPCS%2020/SPCS%20Power%20Swing%20Report_Final_20131015.pdf)



Organization	Yes or No	Question 1 Comment
		<p>relays were evaluated under a criteria to rule out operation due to stable or unstable power swings.</p> <p>The listed Rationale for R2 gives mention to the review of relay tripping is addressed in other NERC Reliability Standards, so there seems to be a nod given to PRC-004, but it should be clearer as to the interrelationship between these standards. Significant confusion could result if the interrelationship or dividing line (whichever is more appropriate) between these two standards is defined further. Will compliance with R2 and R3 of PRC-026 only involve having the data for the operations determined to be caused by power swings, or will it require data that entities provide documentation of the evaluation each operation for power swing implications?</p> <p><b>Response:</b> The standard drafting team has removed the previous Requirements R2 and R3 (Transmission Owner and Generator Owner) that required notification to the Planning Coordinator, in Requirement R1, of Element trips due to stable or unstable power swings. In deleting Requirements R2 and R3, the standard drafting team revised Requirement R4 (now Requirement R2) for load-responsive relays to be evaluated under two conditions:</p> <p>Notification of an Element pursuant to Requirement R1 where the evaluation of the Element has not been performed in the last five calendar years, or</p> <p>Becoming aware of an Element that tripped in response to a stable or unstable power swing.</p> <p>The standard drafting team has provided supporting detail on the second bullet in the Guidelines and Technical Basis under the heading “Becoming Aware of an Element That Tripped in Response to a Power Swing” on how an entity would “become aware.” Changes made.</p>
ISO New England	No	<p>While we agree with the removal of the Reliability Coordinator and Transmission Planner, we don’t believe that entities should be exempted from the standard by the linkage to Attachment A. Attachment A excludes Relay elements supervised by power</p>

Organization	Yes or No	Question 1 Comment
		<p>swing blocking. An entity could just install Out of Step Blocking equipment with nothing to ensure that it is set correctly and the standard would not apply through the exclusion in Attachment A.</p> <p><b>Response:</b> The standard drafting team contends that the installation of power swing blocking relays is an effective means to prevent tripping for stable power swings. The drafting team contends that entities that implement power swing blocking (PSB) relays would do so using engineering judgment and accepted industry practices. A discussion of PSB is in the Application Guidelines. No change made.</p>
Texas Reliability Entity	No	<p>Texas Reliability Entity, Inc. (Texas RE) has concerns regarding the removal of the Reliability Coordinator (RC) from the applicability, particularly for Criteria 1 and 2 of R1. The time horizons that the Planning Coordinator (PC) and RC evaluate are different, with the Planning horizon being &gt; 1 year and the Operations horizon being real-time to &lt; 1 year.</p> <p>When the SDT removed the RC from the applicability, the Operations Planning time horizon was also removed; however, there is still language within Criteria 1 and 2 of R1 addressing angular stability constraints as monitored as part of a System Operating Limit identified in operating studies. Operating studies are not typically conducted by the PC but are conducted by the RC.</p> <p>Based on the language in the Criteria, it is unclear to Texas RE whether the intent of the standard is to only identify elements at risk in the Long-term Planning horizon or to identify elements at risk in both the Operations horizon and the Long-term Planning horizon. Texas RE requests clarification on this issue from the SDT. Please also see our comments to Questions 2 and 3 regarding time horizon concerns.</p> <p><b>Response:</b> The standard drafting team revised Requirement R1, Criterion 1 to replace the phrase “an operating limit” with “System Operating Limit (SOL).” Further, the standard drafting team reworded Requirement R1, Criterion 2 to remove the phrase “identified in system planning or operating studies” and clarify that the SOL is identified based on the Planning Coordinator’s methodology in the planning horizon.</p>

Organization	Yes or No	Question 1 Comment
		<p>This revision aligns use of the term in the standard with the <i>Glossary of Terms Used in NERC Reliability Standards</i> defined term, “System Operating Limit” or “SOL.” Also, this revision aligns the use of “SOL” with the Planning Coordinator’s methodology of how SOLs are developed according to FAC-10 (System Operating Limits Methodology for the Planning Horizon). Change made.</p>
<p>Consumers Energy Company</p>	<p>No</p>	<p>The Transmission Owner and Generator Owner on their own do not have the capability to determine if a trip was caused due to a swing. In most cases the Generator Owner has no knowledge of events on the transmission system, and in many cases the Transmission Owner may only own one terminal of a transmission line. Given the available data for a single terminal, there is no reliable way for an Owner to determine if a trip was due to a fault or a swing. The Transmission Planner and/or Reliability Coordinator have the broad system perspective to track how a swing moves through the transmission system and impacts each element and should determine whether any given event was involved a swing through a specific Element.</p> <p><b>Response:</b> The standard drafting team has removed the previous Requirements R2 and R3 (Transmission Owner and Generator Owner) that required notification to the Planning Coordinator, in Requirement R1, of Element trips due to stable or unstable power swings. In deleting Requirements R2 and R3, the standard drafting team revised Requirement R4 (now Requirement R2) for load-responsive relays to be evaluated under two conditions:</p> <p>Notification of an Element pursuant to Requirement R1 where the evaluation of the Element has not been performed in the last five calendar years, or</p> <p>Becoming aware of an Element that tripped in response to a stable or unstable power swing.</p> <p>The standard drafting team has provided supporting detail on the second bullet in the Guidelines and Technical Basis under the heading “Becoming Aware of an Element</p>

Organization	Yes or No	Question 1 Comment
		That Tripped in Response to a Power Swing” on how an entity would “become aware.” Changes made.
California ISO	No	<p>The California ISO does not agree with the change to remove the Transmission Planner in the Applicability section and in Requirement R1. The California ISO supports continuing to include the Transmission Planner in Requirement R1 as suggested by the PSRPS Report.</p> <p><b>Response:</b> The standard drafting team removed the Reliability Coordinator and Transmission Planner as applicable entities in Draft 2 of the proposed standard in response to comments to address concerns about overlap and potential gaps when identifying Elements in Requirement R1. Although the PSRPS Report<sup>5</sup> suggested entities for applicability, the standard drafting team agreed with comments received on Draft 1 and that the Planning Coordinator is in the best position to identify Elements to avoid duplication and potential gaps. No change made.</p>
Northeast Power Coordinating Council	Yes	
Arizona Public Service Co	Yes	
Puget Sound Energy	Yes	
Southern Company: Southern Company Services, Inc.; Alabama Power Company; Georgia Power Company; Gulf Power Company;	Yes	<p>Simplifying the requirement to a single entity clarified the responsibilities.</p> <p><b>Response:</b> The standard drafting team thanks you for your comment.</p>

<sup>5</sup> NERC System Protection and Control Subcommittee, *Protection System Response to Power Swings*, August 2013: [http://www.nerc.com/comm/PC/System%20Protection%20and%20Control%20Subcommittee%20SPCS%202020/SPCS%20Power%20Swing%20Report\\_Final\\_20131015.pdf](http://www.nerc.com/comm/PC/System%20Protection%20and%20Control%20Subcommittee%20SPCS%202020/SPCS%20Power%20Swing%20Report_Final_20131015.pdf)

Organization	Yes or No	Question 1 Comment
Mississippi Power Company; Southern Company Generation; Southern Company Generation and Energy Marketing		
Colorado Springs Utilities	Yes	No Comments
Duke Energy	Yes	
ISO RTO Council Standards Review Committee	Yes	<p>The Standards Review Committee (SRC) agrees with the removal of the Reliability Coordinator and Transmission Planner; however, there remains concern that that entities could be exempted from the standard by the linkage to Attachment A as it excludes Relay elements supervised by power swing blocking. The SRC, therefore, recommends that the SDT assure all Applicability is explicit in the Applicability Section of the standard and that exemptions or other criteria are not embedded in Attachment A. (note CAISO does not support the response to Question 1)</p> <p><b>Response:</b> The standard drafting team contends that the installation of power swing blocking relays is an effective means to prevent tripping for stable power swings. The drafting team contends that entities that implement power swing blocking (PSB) relays would do so using engineering judgment and accepted industry practices. A discussion of PSB is in the Application Guidelines. No change made.</p>
Dominion	Yes	
JEA	Yes	
DTE Electric Co.	Yes	

Organization	Yes or No	Question 1 Comment
FirstEnergy Corp.	Yes	
Tennessee Valley Authority	Yes	
SPP Standards Review Group	Yes	<p>Thank you for removing the Reliability Coordinator function. The Reliability Coordinator has no place in this standard.</p> <p><b>Response:</b> The standard drafting team thanks you for your comment.</p>
ACES Standards Collaborators	Yes	<p>(1) We largely agree with the applicability changes. We thank the drafting team for removing Transmission Planner and avoiding the confusion that has occurred in so many other standards from joint responsibility to meet the same requirements as the PC.</p> <p><b>Response:</b> The standard drafting team thanks you for your comment.</p> <p>(2) We are concerned with the removal of the RC. Per the SDT’s response to our comments regarding which SOLs (planning horizon is covered FAC-010 and operating horizon is covered in FAC-011), the SDT indicated that they intended for both to apply. Since the SOL methodology that applies in the operating time horizon is written by the RC, the PC may not be familiar enough with the RC’s methodology to determine which operating horizon SOLs are due to angular stability. Wouldn’t it be easier for the RC to notify the PC of those operating SOLs caused by angular stability?</p> <p><b>Response:</b> The standard drafting team revised Requirement R1, Criterion 1 to replace the phrase “an operating limit” with “System Operating Limit (SOL).” Further, the standard drafting team reworded Requirement R1, Criterion 2 to remove the phrase “identified in system planning or operating studies” and clarify that the SOL is identified based on the Planning Coordinator’s methodology in the planning horizon. This revision aligns use of the term in the standard with the <i>Glossary of Terms Used in NERC Reliability Standards</i> defined term, “System Operating Limit” or “SOL.” Also, this revision aligns the use of “SOL” with the Planning Coordinator’s methodology of how</p>

Organization	Yes or No	Question 1 Comment
		SOLs are developed according to FAC-10 (System Operating Limits Methodology for the Planning Horizon). Change made.
Bonneville Power Administration	Yes	
Oncor Electric Delivery LLC	Yes	
Public Service Enterprise Group	Yes	
Entergy Services, Inc.	Yes	
American Electric Power	Yes	
Seminole Electric Cooperative, Inc.	Yes	
Independent Electricity System Operator	Yes	
Xcel Energy	Yes	
Luminant Generation Company, LLC	Yes	
Wisconsin Electric	Yes	
City of Tallahassee	Yes	

Organization	Yes or No	Question 1 Comment
Idaho Power	Yes	
Kansas City Power & Light	Yes	
Pepco Holdings Inc.	Yes	
CPS Energy	Yes	
Nebraska Public Power District (NPPD)	Yes	
Tacoma Power	Yes	
Ameren	Yes	
ITC	Yes	
Hydro One	Yes	
Hydro One	Yes	
Manitoba Hydro	Yes	
Lower Colorado River Authority	Yes	
Georgia Transmission Corporation	Yes	
CenterPoint Energy	Yes	



Organization	Yes or No	Question 1 Comment
Tri-State Generation and Transmission Association, Inc.	Yes	
PPL NERC Registered Affiliates		<p>These comments are submitted on behalf of the following PPL NERC Registered Affiliates: LG&amp;E and KU Energy, LLC; PPL Electric Utilities Corporation, PPL EnergyPlus, LLC; PPL Generation, LLC; PPL Susquehanna, LLC; and PPL Montana, LLC. The PPL NERC Registered Affiliates are registered in six regions (MRO, NPCC, RFC, SERC, SPP, and WECC) for one or more of the following NERC functions: BA, DP, GO, GOP, IA, LSE, PA, PSE, RP, TO, TOP, TP, and TSP.</p> <p><b>Response:</b> The standard drafting team thanks you for your comment.</p>

2. Do you agree that the revisions to Requirement R1 improved clarity while remaining consistent with the focused approach of using the Criteria which came from recommendations in the PSRPS technical document (pg. 21 of 61)? If not, please explain why and provide an alternative, if any.

**Summary Consideration:** Two-thirds of commenters agreed that the revisions improved clarity while remaining consistent with the focused approach of using the Requirement R1 criteria which is supported by the recommendation in the PSRPS Report<sup>6</sup> (pg. 21 of 61). The following summary discusses the most significant concerns that resulted in a revision to the Standard and one minor concern that did not result in a change to the Standard.

There were only three significant themes of comments that resulted in a revision to the Standard. First, two comments supported by 13 individuals requested that Requirement R1 be split into two Requirements, one for identifying BES Elements and one for notifying the Generator Owner and Transmission Owner. The drafting team did not agree and alternatively modified Requirement R1 to place the performance on notification of the Element(s) based on the criteria. Notifying the Generator Owner and Transmission any Elements that meet the criteria infers that the identification is being performed in order to determine what BES Elements must be provided in a notification, if any. Second, two comments each from an individual requested clarity between the lowercase phrase “operating limit” and the NERC defined term, “System Operating Limit” or SOL. The standard drafting team revised the Standard to use “SOL” exclusively for clarity since the methodology for determining of SOLs is addressed by the NERC Reliability Standard FAC-010.<sup>7</sup> Third, only one comment provided minor editorial corrections to the Standard which the standard drafting team implemented.

The following summarizes comment themes that did not result in a change to the Standard. First, nine comments supported by 46 individuals (including Questions 1-8) commented that the Standard is going beyond the intent of the Federal Energy Regulatory Commission (FERC) Order No. 733. The standard drafting team responded that it is important to note that this Standard does not require that entities assess Protection System performance during unstable swings and does not require entities to prevent tripping in response to unstable swings. Therefore, the Standard focuses on the identification of Elements by the Planning Coordinator (Requirement R1) and Elements where the Generator Owner or Transmission Owner becomes aware of an Element that tripped in response to either a stable or unstable power swing (Draft 3, Requirement R2, 2nd bullet). Requirements R1 and R2 (2nd bullet) is a screen to identify Elements that are subject to the Requirements of the Standard, and not require that entities assess Protection System performance during unstable swings.

<sup>6</sup> NERC System Protection and Control Subcommittee, *Protection System Response to Power Swings*, August 2013: [http://www.nerc.com/comm/PC/System%20Protection%20and%20Control%20Subcommittee%20SPCS%2020/SPCS%20Power%20Swing%20Report\\_Final\\_20131015.pdf](http://www.nerc.com/comm/PC/System%20Protection%20and%20Control%20Subcommittee%20SPCS%2020/SPCS%20Power%20Swing%20Report_Final_20131015.pdf)

<sup>7</sup> System Operating Limits Methodology for the Planning Horizon

The FERC Order No. 733 directive is perceived as broad and overreaching and could require all relays to be capable of differentiating between stable power swings and faults. This standard's focused approach is based on the PSRPS Report, recommending "...lines that have tripped due to power swings during system disturbances..." as one of the ways to focus the evaluation. Based on feedback from the contributors to the PSRPS Report, that recommendation does not exclude "unstable" power swings. Furthermore, it is reasonable to assume that an Element that experiences an unstable swing (in either a simulation or reality) is likely to experience large stable power swings for less severe disturbances (that are probably more likely to occur). Thus, the standard drafting team concluded that addressing Protection Systems for Elements that tripped due to "unstable" power swings provides a reliability benefit.

Second, eight comments supported by 32 individuals noted that the entities are not persuaded that a Standard is needed, primarily because of the PSRPS Report. The standard drafting team addressed entity concerns about not pursuing a standard in the previous posting of the Consideration of Comments to Draft 1.<sup>8</sup>

Third, six comments represented by 36 individuals submitted general questions and comments about the Standard, which did not result in a revision based on the comments. For example, why is the Planning Coordinator required to notify the Generator Owner and Transmission Owner each calendar year of the BES Element(s) that tripped based on Requirement R1, Criterion 3 concerning underfrequency load shedding (UFLS).<sup>9</sup> Since Draft 3, Requirement R2 has a re-evaluation component driven by the BES Element notification by the Planning Coordinator and a point in time of the last evaluation, the standard drafting team concluded that not including additional language for varying assessments done by the Planning Coordinator reduces complexity and does not result in a significant burden. Another comment questioned why the Standard required the Generator Owner and Transmission Owner to notify the Planning Coordinator. The reason was to create a loopback for the re-evaluation; however, the standard drafting team based on other comments later removed Requirement R1, Criterion 5 and Requirements R2 and R3 due to determining a better way to address actual events due to stable or unstable power swings. One comment wanted additional work to align the Standard with TPL-001-4 and another to add back in the Transmission Planner to the Standard's Applicability.

Fourth, four comments supported by 17 individuals (including Questions 1-8) wanted the Standard to provide a Requirement for the exchange of information (e.g., system impedance data); however, the standard drafting team concluded that a Requirement for the information exchange would be administrative and have limited reliability benefit for activities that entities are already performing.

---

<sup>8</sup> [http://www.nerc.com/pa/Stand/Project%202010133%20Phase%203%20of%20Relay%20Loadability%20stabl/Project\\_2010\\_13.3\\_Consideration\\_of\\_Comments\\_2014\\_08\\_22\\_to\\_Draft\\_1.pdf](http://www.nerc.com/pa/Stand/Project%202010133%20Phase%203%20of%20Relay%20Loadability%20stabl/Project_2010_13.3_Consideration_of_Comments_2014_08_22_to_Draft_1.pdf)

<sup>9</sup> NERC Reliability Standard PRC-006-1 – *Automatic Underfrequency Load Shedding* has a five year periodicity.

Last, two comments represented by 32 individuals suggested rewording Requirement R1 to include the phrase “...for all design criteria events...” The standard drafting team agreed that the suggestion did not add clarity to Requirement R1.

Organization	Yes or No	Question 2 Comment
Colorado Springs Utilities	No	<p>We agree with the Public Service Electric and Gas Company comments.</p> <p><b>Response:</b> The standard drafting team thanks you for participating, please see the responses to Public Service Enterprise Group.</p> <p>Additional Comments:</p> <p>1.) Please define a "transmission switching station," is that the same thing as a sub-station?</p> <p><b>Response:</b> The standard drafting team revised the phrase “transmission switching station” to be “Transmission station” to refer to the <i>Glossary of Terms Used in NERC Reliability Standards</i>. Change made.</p> <p>2.) Please clarify "angular" stability limit versus just a stability limit.</p> <p><b>Response:</b> The descriptor “angular” was added in Draft 2 to clarify that the “stability limit” pertains to an angular stability limit and not a voltage stability limit, for example. No change made.</p> <p>3.) How are people modeling the relay settings for R1.4? Our facility ratings take into account relay setting limitations and the facility ratings are used in the models. Is that sufficient modeling or is there some specific modeling expected for R1.4?</p> <p><b>Response:</b> The standard drafting team notes that Requirement R1, Criterion 4 provides a mechanism for the Planning Coordinator to identify Element in the most recent annual Planning Assessment where relay tripping occurs due to a stable or unstable power swing during a simulated disturbance. As discussed in the Guidelines and Technical Basis, the soon-to-be enforceable TPL-001-4 Reliability Standard calls for the use generic or actual relay models. It will be through a Planning Coordinator’s compliance with TPL-001-4 that Elements will be identified where relay tripping occurs</p>

Organization	Yes or No	Question 2 Comment
		<p>due to a stable or unstable power swing during a simulated disturbance. PRC-026-1 does not require modeling of relays in planning studies. No change made.</p>
<p>PPL NERC Registered Affiliates</p>	<p>No</p>	<p>The process of PCs annually performing an analysis and notifying TO/GOs of applicable Elements per R1, and of TO/GOs then evaluating these Elements per R4, should be clarified to note that where relays meeting criteria 1-3 of R1 are on the PC’s list year after year a new evaluation is not required each time unless conditions have materially changed (threshold TBD by the SDT).</p> <p><b>Response:</b> The standard drafting team intends that the Planning Coordinator will notify the respective Generator Owner and Transmission Owners annually and that Elements will, from time to time, be added or removed accordingly. In doing so, Requirement R1 supports the re-evaluation in Requirement R4 (now Requirement R2) every five (previously three) calendar years should the Element remain on the list.</p>
<p>SPP Standards Review Group</p>	<p>No</p>	<p>In light of the fact that the purpose of this standard is “To ensure that load-responsive protective relays are expected to not trip in response to stable power swings during non-Fault conditions” which is in agreement with the FERC Order 733 (Section 150 of the FERC Order: “requires the use of protective relay systems that can differentiate between faults and stable power swings and, when necessary, phases out protective relay systems that cannot meet this requirement”), it is an unnecessary extension of the Order to include unstable power swings.</p> <p>The Standard Drafting Team stated “The phrase “stable or unstable” was inserted to clarify that both are applicable to power swings because the goal of the standard is to identify Elements susceptible to either” overreaches the FERC Order.</p> <p>We recommend that the term ‘Unstable Power Swing’ be removed from the standard.</p> <p><b>Response:</b> It is important to note that this standard does not require that entities assess Protection System performance during unstable swings and does not require entities to prevent tripping in response to unstable swings. Such requirements would exceed the directive stated in the Federal Energy Regulatory Commission (FERC) Order</p>

Organization	Yes or No	Question 2 Comment
		<p>No. 733. This standard focuses on the identification of Elements by the Planning Coordinator (Requirement R1) and Elements where the Generator Owner or Transmission Owner becomes aware of an Element that tripped in response to a stable or unstable power swing (Draft 3, Requirement R2, 2<sup>nd</sup> bullet). Requirements R1 and R2 (2<sup>nd</sup> bullet) is a screen to identify Elements that are subject to the Requirements of the standard.</p> <p>The FERC Order No. 733 directive is perceived as broad and overreaching and could require all relays to be capable of differentiating between stable power swings and faults. This standard’s focused approach is based on the PSRPS Report,<sup>10</sup> recommending “...lines that have tripped due to power swings during system disturbances...” as one of the ways to focus the evaluation. Based on feedback from the contributors to the PSRPS Report, that recommendation does not exclude unstable power swings. Furthermore, it is reasonable to assume that an Element that experiences an unstable swing (in either a simulation or reality) is likely to experience large stable power swings for less severe disturbances (that are probably more likely to occur). Thus, the standard drafting team concluded that addressing Protection Systems for Elements that tripped due to unstable power swings provides a reliability benefit. No change made.</p>
Seattle City Light	No	<p>Seattle City Light is not convinced that this Standard is warranted, and does not find comfort in the tortured process associated with developing the recommendations of the PSRPS document. The changes, as far as they go, do add some clarity to R1.</p> <p><b>Response:</b> The standard drafting team thanks you for your comment.</p>
ACES Standards Collaborators	No	<p>(1) We agree that the clarity of Requirement R1 is improved but we still have a couple of concerns.</p>

<sup>10</sup> NERC System Protection and Control Subcommittee, *Protection System Response to Power Swings*, August 2013: [http://www.nerc.com/comm/PC/System%20Protection%20and%20Control%20Subcommittee%20SPCS%2020/SPCS%20Power%20Swing%20Report\\_Final\\_20131015.pdf](http://www.nerc.com/comm/PC/System%20Protection%20and%20Control%20Subcommittee%20SPCS%2020/SPCS%20Power%20Swing%20Report_Final_20131015.pdf)

Organization	Yes or No	Question 2 Comment
		<p><b>Response:</b> The standard drafting team thanks you for your comment.</p> <p>(2) Why is the PC required to notify the GO and TO of Elements that were involved in actual events when the GO and TO are the entities that notify the PC in the first place? Doesn't the PC just need to notify the GO and TO when those Elements are no longer susceptible to tripping from stable power swings?</p> <p><b>Response:</b> The standard drafting team included Criterion 5 in Requirement R1 as a mechanism to (1) create awareness for the Planning Coordinator that has wide-area awareness; and (2) to close the loop back to the Generator Owner or Transmission Owner to continue to re-evaluate its load-responsive protective relays associated with the identified Element; and (3) should the electric system topology change where the Element is no longer susceptible to a power swing as determined by the Planning Coordinator, the Element is no longer required to be identified pursuant to Requirement R1. However, the standard drafting team has revised the standard such that Requirement R1, Criterion 5 has been eliminated, along with Requirements R2 and R3.</p> <p>(3) In Criterion 4, why are unstable power swings included? Elements should trip due to unstable power swings. Why does the GO and TO need to modify relaying for unstable power swings?</p> <p><b>Response:</b> It is important to note that this standard does not require that entities assess Protection System performance during unstable swings and does not require entities to prevent tripping in response to unstable swings. Such requirements would exceed the directive stated in the Federal Energy Regulatory Commission (FERC) Order No. 733. This standard focuses on the identification of Elements by the Planning Coordinator (Requirement R1) and Elements where the Generator Owner or Transmission Owner becomes aware of an Element that tripped in response to a stable or unstable power swing (Draft 3, Requirement R2, 2<sup>nd</sup> bullet). Requirement R1 and R2 (2<sup>nd</sup> bullet) is a screen to identify Elements that are subject to the Requirements of the standard.</p>

Organization	Yes or No	Question 2 Comment
		<p>The FERC Order No. 733 directive is perceived as broad and overreaching and could require all relays to be capable of differentiating between stable power swings and faults. This standard’s focused approach is based on the PSRPS Report,<sup>11</sup> recommending “...lines that have tripped due to power swings during system disturbances...” as one of the ways to focus the evaluation. Based on feedback from the contributors to the PSRPS Report, that recommendation does not exclude unstable power swings. Furthermore, it is reasonable to assume that an Element that experiences an unstable swing (in either a simulation or reality) is likely to experience large stable power swings for less severe disturbances (that are probably more likely to occur). Thus, the standard drafting team concluded that addressing Protection Systems for Elements that tripped due to unstable power swings provides a reliability benefit. No change made.</p> <p>Since PRC-006 only requires the PC to simulate the UFLS Program every five years, it seems that requiring the PC to identify the same Elements that form a UFLS island boundary every year is unnecessary. Criterion 3 should be modified to clarify that this notification is only necessary once every five years when the UFLS study is completed.</p> <p><b>Response:</b> The standard drafting team contends that the Planning Coordinator must notify the Generator Owner and Transmission Owner of the identified Elements annually, even if the specified criteria in Requirement R1 is performed less frequently. The periodicity is reasonable and practical to ensure timely notification of identified Elements to the Generator Owner and Transmission Owner. No change made.</p> <p>The standard drafting team provided additional dialogue about this in the Guidelines and Technical Basis under the heading “Requirement R1.” Change made.</p>

<sup>11</sup> NERC System Protection and Control Subcommittee, *Protection System Response to Power Swings*, August 2013: [http://www.nerc.com/comm/PC/System%20Protection%20and%20Control%20Subcommittee%20SPCS%2020/SPCS%20Power%20Swing%20Report\\_Final\\_20131015.pdf](http://www.nerc.com/comm/PC/System%20Protection%20and%20Control%20Subcommittee%20SPCS%2020/SPCS%20Power%20Swing%20Report_Final_20131015.pdf)



Organization	Yes or No	Question 2 Comment
Public Service Enterprise Group	No	<p>The Planning Coordinator should be obligated in R1 to provide system impedance data as described in the Attachment B Criteria for each Element identified in R1 to the TO or GO that owns the Element. PCs maintain the models that contain this data, and having them provide it will result in consistency for relays set within the PC's area.</p> <p><b>Response:</b> The standard drafting team contends that Generator Owners and Transmission Owners already obtain this information periodically for other purposes and for performance under other NERC Reliability Standards. No change made.</p>
Xcel Energy	No	<p>Criteria 1 uses the term “operating limit” and Criteria 2 uses the term “System Operating Limit;” although both are identified by the existence of angular stability constraints, thus seemingly defining the same type of operating constraint, i.e. operating limit. Xcel Energy would suggest either explaining the difference between the terms “operating limit” and “System Operating Limit”, or eliminating the potentially duplicative criterion, since a “Generator” can be an “Element”.</p> <p><b>Response:</b> The standard drafting team replaced the term “operating limit” with “System Operating Limit (SOL)” in Criterion 1 to be consistent with Criterion 2. Criterion 1 identifies generators and Elements terminating at the Transmission station associated with the generator(s), while Criterion 2 identifies transmission Elements that are monitored as part of an SOL. Change made.</p> <p>In our opinion, Requirement R1 is organized and written in a manner that makes interpretation difficult. Xcel Energy suggests that the drafting team consider re-organizing this requirement as suggested below.</p> <p>R1 could be split so that R1 requires the PC to perform the following at least once per year;</p> <p>R1.1 would require the PC to identify Elements meeting the bulleted list of criteria;</p> <p>R1.2 would require notification to the respective Generator Owner and Transmission owner of each Element identified in R1.1.</p>

Organization	Yes or No	Question 2 Comment
		<p>Regardless of whether this Requirement R1 is re-organized as suggested above or not, we suggest the following rewrite of of Criteria 1 to minimize ambiguity. Criteria 1 can be split either at the “or” (as in “...addressed by an operating limit or a Remedial Action Scheme (RAS) and those Elements...”) or at the “and” (as in “...addressed by an operating limit or a Remedial Action Scheme (RAS) and those Elements...”). To provide additional clarity, Criteria 1 could be rewritten as:</p> <p>”Generator(s) and Elements Terminating at associated transmission stations where angular stability constraint exists that is addressed by an operating limit or a Remedial Action Scheme (RAS).”</p> <p>These potential modifications would improve the readability of the requirement and provide for easier alignment with the associated Measures and VSLs.</p> <p><b>Response:</b> The standard drafting team thanks you for providing suggestions to improve clarity; however, the standard drafting team declines to implement the suggestion to avoid a loss in the intended purpose. No change made.</p> <p>In addition, M1 could be rephrased to state</p> <p>“Each Planning Coordinator shall have dated evidence that demonstrates identification of Elements meeting the R1 criteria was performed on a calendar year basis and dated evidence that demonstrates the respective owners of the identified Elements were notified on a calendar year basis”.</p> <p><b>Response:</b> The standard drafting team declines to make the modification since Requirement R1 was not modified according to the previous comment.</p> <p>The existing M1 phrasing of “identification and respective notification of the Elements” reads as if the Elements are being notified rather than the owners of the Elements.</p> <p><b>Response:</b> The standard drafting team made an editorial revision to Measure M1 to address the issue raised in the comment. Change made.</p>

Organization	Yes or No	Question 2 Comment
Luminant Generation Company, LLC	No	<p>Requirement R1 provides additional clarity of which Elements (including transformers, generators) are included in a notification by the Transmission Planner. In light of the fact that the purpose of this standard is “To ensure that load-responsive protective relays are expected to not trip in response to stable power swings during non-Fault conditions” which is in agreement with the FERC Order 733 (Section 150 of the FERC Order: “requires the use of protective relay systems that can differentiate between faults and stable power swings and, when necessary, phases out protective relay systems that cannot meet this requirement”), it is an unnecessary extension of the Order to include unstable power swings. The Standard Drafting Team stated “The phrase “stable or unstable” was inserted to clarify that both are applicable to power swings because the goal of the standard is to identify Elements susceptible to either” overreaches the FERC Order. Luminant recommends that unstable power swings be removed.</p> <p><b>Response:</b> It is important to note that this standard does not require that entities assess Protection System performance during unstable swings and does not require entities to prevent tripping in response to unstable swings. Such requirements would exceed the directive stated in the Federal Energy Regulatory Commission (FERC) Order No. 733. This standard focuses on the identification of Elements by the Planning Coordinator (Requirement R1) and Elements where the Generator Owner or Transmission Owner becomes aware of an Element that tripped in response to a stable or unstable power swing (Draft 3, Requirement R2, 2<sup>nd</sup> bullet). Requirement R1 and R2 (2<sup>nd</sup> bullet) is a screen to identify Elements that are subject to the Requirements of the standard.</p> <p>The FERC Order No. 733 directive is perceived as broad and overreaching and could require all relays to be capable of differentiating between stable power swings and faults. This standard’s focused approach is based on the PSRPS Report,<sup>12</sup></p>

<sup>12</sup> NERC System Protection and Control Subcommittee, *Protection System Response to Power Swings*, August 2013: [http://www.nerc.com/comm/PC/System%20Protection%20and%20Control%20Subcommittee%20SPCS%2020/SPCS%20Power%20Swing%20Report\\_Final\\_20131015.pdf](http://www.nerc.com/comm/PC/System%20Protection%20and%20Control%20Subcommittee%20SPCS%2020/SPCS%20Power%20Swing%20Report_Final_20131015.pdf)

Organization	Yes or No	Question 2 Comment
		<p>recommending “...lines that have tripped due to power swings during system disturbances...” as one of the ways to focus the evaluation. Based on feedback from the contributors to the PSRPS Report, that recommendation does not exclude unstable power swings. Furthermore, it is reasonable to assume that an Element that experiences an unstable swing (in either a simulation or reality) is likely to experience large stable power swings for less severe disturbances (that are probably more likely to occur). Thus, the standard drafting team concluded that addressing Protection Systems for Elements that tripped due to unstable power swings provides a reliability benefit. No change made.</p> <p>Additionally, R1 should be modified so that notifications are not required for elements and relays that were previously identified and are currently in a Corrective Action Plan.</p> <p><b>Response:</b> The standard drafting team contends that providing additional caveats and stipulations in the requirements does not provide a reliability benefit and only complicates the clarity and intent of the Requirements. No change made.</p> <p>The Planning Assessment referenced in R1, Criteria 4 should be limited to the contingencies in TPL-001-0.1 “Table 1 Transmission System Standards - Normal and Emergency Conditions” Category A, B, C and D to focus the power swing evaluations and corrective action development on activities that support the reliability of the BES.</p> <p><b>Response:</b> The standard drafting team contends that the proposed standard is in alignment with the TPL-001-4 Reliability Standard, which becomes effective on January 1, 2015. Furthermore, the contingencies to which the Planning Coordinator will consider have not been specified in the Requirement R1 criteria because there is no certainty to what system conditions may produce a stable or unstable power swing on a particular Element within the study. The criterion do not require the Planning Coordinator to specifically evaluate for a power swing, only identify the Element if observed as tripping during a simulated Disturbance. No change made.</p>
City of Tallahassee	No	The Planning Coordinator should be obligated in R1 to provide system impedance data as described in the Attachment B Criteria for each Element identified in R1 to the TO

Organization	Yes or No	Question 2 Comment
		<p>or GO that owns the Element. PCs maintain the models that contain this data, and having them provide it will result in consistency for relays set within the PC's area.</p> <p><b>Response:</b> The standard drafting team contends that Generator Owners and Transmission Owners already obtain this information periodically for other purposes and for performance under other NERC Reliability Standards. No change made.</p>
ISO New England	No	<p>R1 should be changed to read:</p> <p>R1. Each Planning Coordinator shall, for all design criteria events at least once each calendar year, identify each Element in its area that meets one or more of the following criteria and provide notification to the respective Generator Owner and Transmission Owner, if any:</p> <p><b>Response:</b> The standard drafting team contends that the provided suggestion "...for all design criteria events..." does not add clarity to Requirement R1. No change made.</p>
Kansas City Power & Light	No	<p>A yearly notification is too often for this requirement since this information will rarely change. We suggest a yearly notification for any change from the previous year, with a five year notification of all identified Elements.</p> <p><b>Response:</b> The standard drafting team contends that the Planning Coordinator must notify the Generator Owner and Transmission Owner of the identified Elements annually, even if the specified criteria in Requirement R1 is performed less frequently. The periodicity is reasonable and practical to ensure timely notification of identified Elements to the Generator Owner and Transmission Owner. No change made.</p>
CPS Energy	No	<p>In general, support Luminant comments.</p> <p><b>Response:</b> The standard drafting team thanks you for your comment.</p>
Nebraska Public Power District (NPPD)	No	<p>The PSRPS Recommendations Section states that the SPCS determined a Reliability Standard is not needed.</p>

Organization	Yes or No	Question 2 Comment
		<p><b>Response:</b> The standard drafting team thanks you for your comment and provided a detailed explanation in the previous Consideration of Comments<sup>13</sup> in the introductory remarks regarding the need for a standard to meet regulatory directives.</p>
Georgia Transmission Corporation	No	<p>Recommend further clarity and a revision to R1 criteria 1 such as:</p> <p>From this:</p> <p>Generator(s) where an angular stability constraint exists that is addressed by an operating limit or a Remedial Action Scheme (RAS) and those Elements terminating at the transmission switching station associated with the generator(s).</p> <p>To this:</p> <p>Generator(s) and those interconnecting Elements terminating at the transmission switching station associated with the generator(s), where an angular stability constraint exists that is addressed by an operating limit or a Remedial Action Scheme (RAS).</p> <p><b>Response:</b> The standard drafting team thanks you for providing suggestions to improve clarity; however, the standard drafting team declines to implement the suggestion to avoid a loss in the intended purpose. No change made.</p>
California ISO	No	<p>The California ISO does not agree with the change to remove the Transmission Planner in the Applicability section and in Requirement R1. The California ISO supports continuing to include the Transmission Planner in Requirement R1 as suggested by the PSRPS Report.</p> <p><b>Response:</b> The standard drafting team removed the Reliability Coordinator and Transmission Planning as applicable entities in Draft 2 of the proposed standard in response to comments to address concerns about overlap and potential gaps when</p>

<sup>13</sup> [http://www.nerc.com/pa/Stand/Project%202010133%20Phase%203%20of%20Relay%20Loadability%20stabl/Project\\_2010\\_13.3\\_Consideration\\_of\\_Comments\\_2014\\_08\\_22\\_to\\_Draft\\_1.pdf](http://www.nerc.com/pa/Stand/Project%202010133%20Phase%203%20of%20Relay%20Loadability%20stabl/Project_2010_13.3_Consideration_of_Comments_2014_08_22_to_Draft_1.pdf)

Organization	Yes or No	Question 2 Comment
		identifying Elements in Requirement R1. Although the v suggested entities for applicability, the standard drafting team agreed with comments on Draft 2 and that the Planning Coordinator is in the best position to identify Elements to avoid duplication and potential gaps. No change made.
Northeast Power Coordinating Council	Yes	<p>Comments regarding requirement R1 can be found in the response to Question 8.</p> <p>Additionally, suggest clarifying requirement R1 by adding the wording “for all design criteria events” so as to make it read: R1. Each Planning Coordinator shall, for all design criteria events, at least once each calendar year, identify each Element in its area that meets one or more of the following criteria and provide notification to the respective Generator Owner and Transmission Owner, if any:</p> <p><b>Response:</b> The standard drafting team contends that the provided suggestion “...for all design criteria events...” does not add clarity to Requirement R1. No change made.</p>
Arizona Public Service Co	Yes	
Puget Sound Energy	Yes	
Southern Company: Southern Company Services, Inc.; Alabama Power Company; Georgia Power Company; Gulf Power Company; Mississippi Power Company; Southern Company Generation; Southern Company Generation and Energy Marketing	Yes	<p>Simplifying the requirement to a single entity clarified the responsibilities.</p> <p><b>Response:</b> The standard drafting team thanks you for your comment.</p>

Organization	Yes or No	Question 2 Comment
Duke Energy	Yes	
ISO RTO Council Standards Review Committee	Yes	<p>The SRC agrees that the revisions improved the clarity of Requirement R1. However, to ensure consistency with the other requirements within the Standard, the SDT recommends that Requirement R1 also be broken into two (2) requirements, one addressing identification and one addressing notification.</p> <p><b>Response:</b> The standard drafting team revised Requirement R1 to focus on the notification of Elements to the Generator Owner and Transmission Owner that meet one or more of the criteria, not on the identification of the Elements which are identified by other studies. Change made.</p> <p>Additionally, Requirement R1 should be changed to read:</p> <p>R1. Each Planning Coordinator shall, for all design criteria events at least once each calendar year, identify each Element in its area that meets one or more of the following criteria and provide notification to the respective Generator Owner and Transmission Owner, if any:</p> <p><b>Response:</b> The standard drafting team contends that the provided suggestion “...for all design criteria events...” does not add clarity to Requirement R1. No change made.</p> <p>Finally, the SRC recommends the following revision to Criterion 1 of Requirement R1 to streamline and ensure that the focus remains on Remedial Action Schemes:</p> <p>1. Generator(s) where an angular stability constraint exists that is addressed by a Remedial Action Scheme (RAS) and those Elements terminating at the transmission switching station associated with the generator(s).</p> <p><b>Response:</b> The standard drafting team thanks you for providing suggestions to improve clarity; however, the standard drafting team declines to implement the suggestion to avoid a loss in the intended purpose. No change made.</p>
Dominion	Yes	



Organization	Yes or No	Question 2 Comment
Florida Municipal Power Agency	Yes	
DTE Electric Co.	Yes	
FirstEnergy Corp.	Yes	<p>FirstEnergy suggests a slight modification to the wording of R1 Criteria 5 for clarity, as follows: “An Element reported by the Transmission Owner pursuant to Requirement R2 or Generator Owner pursuant to R3, unless ...”.</p> <p><b>Response:</b> The standard drafting team has revised the standard such that Requirement R1, Criterion 5 has been eliminated, along with Requirements R2 and R3.</p>
Tennessee Valley Authority	Yes	<p>The addition of criteria 5 seems circular in that the PC is notifying the GO or TO about Elements they already know about. If the PC’s analysis applying criteria 1-4 does not identify these Elements initially, why should the same PC criteria be entrusted to determine that “the Element is no longer susceptible to power swings”?</p> <p><b>Response:</b> The standard drafting team has revised the standard such that Requirement R1, Criterion 5 has been eliminated, along with Requirements R2 and R3.</p>
Bonneville Power Administration	Yes	<p>BPA requests a revision to R1 to separate <b>customer notifications</b> from <b>technical analysis</b>.</p> <p>R1.1 Each Planning Coordinator shall, at least once each calendar year, identify each Element in its area that meets one or more of the following criteria</p> <p>R1.2 Each Planning Coordinator shall provide notification to each respective Generator Owner or Transmission Owner that owns an Element identified in R1.1.</p> <p><b>Response:</b> The standard drafting team revised Requirement R1 to focus on the notification of Elements to the Generator Owner and Transmission Owner that meet one or more of the criteria, not on the identification of the Elements which are identified by other studies. Change made.</p>

Organization	Yes or No	Question 2 Comment
Oncor Electric Delivery LLC	Yes	
Entergy Services, Inc.	Yes	
American Electric Power	Yes	
Independent Electricity System Operator	Yes	
Wisconsin Electric	Yes	
Idaho Power	Yes	
Pepco Holdings Inc.	Yes	
Tacoma Power	Yes	
Ameren	Yes	
ITC	Yes	
Texas Reliability Entity	Yes	<p>While Texas RE agrees with the approach of using criteria from the PSRPS technical document, we have concerns about the stated time horizon. Requirement R1 Criterion 2 states that the PC should include elements identified in operating studies, but the time horizon for this requirement is Long-term Planning. Texas RE suggests that either the Operations Planning time horizon needs to be added to this requirement or the reference to operating studies needs to be removed, whichever is in line with the intent of the SDT.</p> <p><b>Response:</b> The standard drafting team revised Requirement R1, Criterion 1 to replace the phrase “an operating limit” with “System Operating Limit (SOL).” Further, the</p>

Organization	Yes or No	Question 2 Comment
		<p>standard drafting team reworded Requirement R1, Criterion 2 to remove the phrase “identified in system planning or operating studies” and clarify that the SOL is identified based on the Planning Coordinator’s methodology in the planning horizon. This revision aligns use of the term in the standard with the <i>Glossary of Terms Used in NERC Reliability Standards</i> defined term, “System Operating Limit” or “SOL.” Also, this revision aligns the use of “SOL” with the Planning Coordinator’s methodology of how SOLs are developed according to FAC-10 (System Operating Limits Methodology for the Planning Horizon). Change made.</p>
Manitoba Hydro	Yes	
Lower Colorado River Authority	Yes	
American Transmission Company, LLC	Yes	
Tri-State Generation and Transmission Association, Inc.	Yes	
Consumers Energy Company	Yes	
Arizona Public Service	Yes	

3. The previous Requirement R2 was split into Requirement R2 for the Transmission Owner and Requirement R3 for the Generator Owner in order to clarify the performance for identifying Elements that trip. Did this revision improve the understanding of what is required? If not, please explain why the Requirement(s) need additional clarification.

**Summary Consideration:** Almost two-thirds of entities providing comment agree that Requirements R2 and R3 provided clarity over the previous Draft 2. Below is a summary of the comments received about the two Requirements that required the Transmission Owner (Requirement R2) and the Generator Owner (Requirement R3) to provide notification of any BES Element that tripped due to a stable or unstable power swing.

There were two significant themes of comments that resulted in a revision to the Standard. First, fifteen comments supported by 55 individuals expressed concerns about a number of issues regarding Requirements R2 and R3. These concerns included, but are not limited to: 1) the 30 day notification time frame by the Generator Owner and Transmission Owner to the Planning Coordinator was too short; 2) the Measures (M2 and M3) focused on identification of the BES Elements whereas the Requirements only addressed notification; 3) additional detail about BES Elements that form a boundary of an island; 4) the ability to “identify a stable or unstable power swing;” 5) the review of a Protection System within PRC-026-1 and potential conflicts or overlaps with NERC Reliability Standard PRC-004<sup>14</sup> that addresses identification of Misoperations of Protection Systems; 6) how is the starting point established for the purpose of measuring performance of the Requirement; 7) inconsistency with the Violation Severity Levels (VSL); and 8) more information needed on how to identify powers swings.

To address these concerns, the standard drafting team removed the previous Requirements R2 (Transmission Owner) and R3 (Generator Owner) that required notification to the Planning Coordinator, in Requirement R1, of Element that tripped due to stable or unstable power swings. In deleting Requirements R2 and R3, the standard drafting team revised Draft 3, Requirement R2 (previously Draft 2, Requirement R4) for load-responsive relays to be evaluated under two conditions:

- Notification of an Element pursuant to Requirement R1 where the evaluation of the Element has not been performed in the last five calendar years, or
- Becoming aware of an Element that tripped in response to a stable or unstable power swing.

The standard drafting team provided supporting detail on the second bullet (above) in the Guidelines and Technical Basis under the heading “Becoming Aware of an Element That Tripped in Response to a Power Swing” on how an entity would “become aware.”

---

<sup>14</sup> Protection System Misoperation Identification and Correction.

Second, six comments supported by 19 individuals commented that the Standard should not require the Generator Owner and Transmission Owners to identify “unstable” power swings. Comments stemmed from concerns over the ability to identify (e.g., needing digital fault recording), overstepping the Federal Energy Regulatory Commission (FERC) Order No. 733 directive to address only stable, and that the Standard seems to require that entities track every BES Element trip to prove that the entity reviewed it for stable and unstable power swing. To address this concern, the standard drafting team removed Requirements R2 and R3 and incorporated a change to Requirement R2 (previously R4) for when an entity “becomes aware” of a stable or unstable power swing that tripped its BES Element. Performance is required when the entity “becomes aware” of a generator, transformer, or transmission line BES Element that tripped in response to a stable or unstable power swing due to the operation of its protective relay(s).

The following summarizes comments did not result in a change to the Standard. First, two comments each from an individual concerned that the Standard is limiting an entity’s ability to trip for “unstable” power swings. The Draft 3, Requirement R2 (previously Draft 2, Requirement R4) ensures that the Protection System will be evaluated after tripping for an “unstable” power swing to ensure that the Protection System is expected to not trip for a “stable” power swing. The Protection System is not precluded from tripping in response to an unstable power swing. The standard drafting team contends that any out-of-step tripping requirements would be identified independent of this standard and, if required, would need to remain in service.

Last, an individual commented that the Standard should exclude trips during black-starting and system restoration. The standard drafting team disagreed because trips that occur during these circumstances should be evaluated to ensure that load-responsive protective relays are expected to not trip in response to a stable power swing during non-Fault conditions.

Organization	Yes or No	Question 3 Comment
Puget Sound Energy	No	<p>In general, we agree with the comments submitted by PSEG.</p> <p>R2 and R3 require TOs and GOs, respectively, to notify their Planning Coordinator within 30 days of identifying any Element that trips due to a power swing during a system disturbance due to the operation of load-responsive protective relays. PRC-026-1, as drafted, will have consequences with respect to an entity’s implementation of a different standard: PRC-004-3 - Protection System Misoperation Identification and Correction - see <a href="http://www.nerc.com/pa/Stand/Reliability%20Standards/PRC-004-3.pdf">http://www.nerc.com/pa/Stand/Reliability%20Standards/PRC-004-3.pdf</a>. NERC has filed PRC-004-3 with FERC for approval.</p>

Organization	Yes or No	Question 3 Comment
		<p>In summary, PRC-004-3 requires each operation of an interrupting device to be evaluated to determine whether a Misoperation occurred. If such a determination is made, the Protection System owner must investigate the occurrence and either</p> <p>(a) provide a declaration that a cause could not be determined or</p> <p>(b) if a cause is determined, develop and implement a Corrective Action Plan (CAP) or explain why corrective actions are beyond its control or would not improve reliability.</p> <p>PRC-004-3 does not require any action with regard to Element trips that are not Misoperations, i.e., “correct operations.” We understand that a Protection System owner would need some documentation to make the distinction between a correct operation and a Misoperation. However, in order to be fully compliant with PRC-026-1 R2 and R3, every Element that trips due to the operation of a load-responsive relay must be evaluated by the entity to determine whether or not the trip was due to a power swing.</p> <p>As discussed on the September 18 webinar on PRC-026-1, the phrase “system Disturbance” has same meaning as the NERC Glossary term for “Disturbance.” In other words, “system” is unnecessary. In addition, a “Fault” was stated to be a “Disturbance.” Therefore, every operation of a load-responsive relay due to a Fault must be examined under PRC-026-1 to identify whether or not the Element tripped due to a power swing.</p> <p>o If an Elements trips due to a Misoperation, the Misoperation would be investigated under PRC-004-3, and if it was caused by a power swing that could easily be reported under PRC-026-1 as a result of the Protection System owner’s compliance with PRC-004-3.</p> <p>Requiring all correct operations be affirmatively evaluated by the Element owner to determine whether they are attributable to a power swing would only “make work” for both the Element owners and their auditors, and the added effort would not improve reliability. Therefore, we propose that the scope of R2 and R3 for correct operations be reduced to a subset of events that are reported to NERC under EOP-004-2 - Event Reporting - see <a href="http://www.nerc.com/pa/Stand/Reliability%20Standards/EOP-004-">http://www.nerc.com/pa/Stand/Reliability%20Standards/EOP-004-</a></p>

Organization	Yes or No	Question 3 Comment
		<p><a href="#">2.pdf</a>. For example, the Disturbances evaluated in PRC-026-1 for correct operations could be limited to some of the events and associated thresholds listed in EOP-004 - Attachment 1. We believe reasonable events would include:</p> <ul style="list-style-type: none"> <li>o Automatic firm load shedding on p. 9</li> <li>o Loss of firm load (preferably limited to non-weather related load loss) on p. 10</li> <li>o System separation (islanding) on p.10</li> <li>o Generation loss on p.10,</li> <li>o Complete loss of off-site power to a nuclear plant on p. 10, and</li> <li>o Transmission loss on p.11.</li> </ul> <p>To couple the two standards together, NERC, which receives event reports under EOP-004-2, would need to notify the applicable TOs and GOs under PRC-026-1 of the time frame of each event. This would allow the Element owners to evaluate whether any Element trips that occurred during the event and which were correct operations were associated with a power swing.</p> <p>Without this notification, Events that happen outside of the Planning Coordinator’s PC Area may not be properly identified by the affected PC. If this is not the intent of the standard, there needs to be a distinction made between whether relays should be evaluated against local disturbances (disturbances within the PC Area) and system-wide disturbances that would be communicated throughout the region.</p> <p><b>Response:</b> The standard drafting team has removed the previous Requirements R2 and R3 (Transmission Owner and Generator Owner) that required notification to the Planning Coordinator, in Requirement R1, of Element trips due to stable or unstable power swings. In deleting Requirements R2 and R3, the standard drafting team revised Requirement R4 (now Requirement R2) for load-responsive relays to be evaluated under two conditions:</p>

Organization	Yes or No	Question 3 Comment
		<p>Notification of an Element pursuant to Requirement R1 where the evaluation of the Element has not been performed in the last five calendar years, or</p> <p>Becoming aware of an Element that tripped in response to a stable or unstable power swing.</p> <p>The standard drafting team has provided supporting detail on the second bullet in the Guidelines and Technical Basis under the heading “Becoming Aware of an Element That Tripped in Response to a Power Swing” on how an entity would “become aware.” Changes made.</p> <p>The standard drafting team made revisions to the standard which eliminated the term “Disturbance” as defined by the <i>Glossary of Terms Used in NERC Reliability Standards</i>.</p>
Colorado Springs Utilities	No	<p>We agree with the Public Service Electric and Gas Company comments.</p> <p><b>Response:</b> The standard drafting team thanks you for participating, please see the responses to Public Service Enterprise Group.</p>
ISO RTO Council Standards Review Committee	No	<p>The SRC notes that Requirements R2 and R3 are about notification if an element meeting specified criteria is identified. However, the measures are primarily focused on identification. Accordingly, the measures should be revised for consistency with the associated Requirements R2 and R3.</p> <p><b>Response:</b> The standard drafting team removed Requirements R2 and R3; therefore, the conflict is no longer present. Change made.</p>
Dominion	No	<p>M3 seems to be missing the word ‘meet’; suggest M3 read as; M3. Each Generator Owner shall have dated evidence that demonstrates identification of the Element(s), if any, which ‘meet’ the criterion in Requirement R3. Evidence may include, but is not limited to, the following documentation: emails, facsimiles, records, reports, transmittals, lists, or spreadsheets.</p>



Organization	Yes or No	Question 3 Comment
		<p><b>Response:</b> The standard drafting team removed Requirements R2 and R3; therefore, the issue is no longer present. Change made.</p> <p>Dominion agrees with the split of R2, however, elements could have their load-responsive protective relays operate prior to the formation of an island. In the Application Guide, a section should be included to better define methods used for boundary detection, if we are required to determine if the element was in-fact the boundary to an island. Otherwise, power swings could cause relays to operate without internal detection algorithms picking up the swing.</p> <p><b>Response:</b> The standard drafting team removed Requirements R2 and R3; therefore, the issue is no longer present. Change made.</p>
Florida Municipal Power Agency	No	<p>Requirements R2 and R3 need further clarification. FMPA agrees that splitting the Requirement was beneficial. However, FMPA finds the following issues left requiring resolution, which point to the need to better coordinate this standard with PRC-004:</p> <p>1. The language is crafted as if a typical TO or GO would easily be able to determine that an element tripped due to a power swing. This only makes sense for large vertically integrated utilities in which staff with a variety of knowledge bases and skill sets may be working together. In reality, for smaller utilities that may be only a TO/DP or GO, this determination will require some involvement from a TP, PC, TOP, or RC, with staff that have a) access to real time information, event records, and other information beyond what any single TO or GO may have and b) an understanding of the expected regional stability performance which TO/GO staff may not have. Realistically it should only be presumed the TO or GO staff will be able to conclude that their relays did not trip for a fault.</p> <p><b>Response:</b> The standard drafting team contends that PRC-026-1 does not require an entity to determine whether an Element tripped due to a power swing. This is accomplished in the revision to Requirement R2 (previously Requirement R4) that when an entity “becomes aware” it would evaluate the relay(s). The identification of a power swing that causes a BES Element trip could be determined through an entity’s</p>

Organization	Yes or No	Question 3 Comment
		<p>Protection System analysis process (e.g., PRC-004<sup>15</sup>), event analysis review by the entity, region, or NERC.</p> <p>2. The standard sets a 30 day clock which starts with a piece of information that isn't required or driven from anywhere - namely, the point in time at which at TO or GO discovers that any relay operated (either correctly or incorrectly) due to a power swing. Since there is currently no place where it is required that correct/proper relay operation be documented, it is not clear what sort of documentation the TO/GO will have and what process, performed by what staff, would drive the TO/GO to "initially discover" that the relay operated due to a power swing. The point being- in a normal PRC-004 investigation, at such time as it is discovered that a relay properly operated, there is no requirement for any formal report, on any formal schedule, to include that information. At what point does the "official" starting point of this 30 day clock occur? This points to the need for further/better coordination with PRC-004.</p> <p><b>Response:</b> The standard drafting team removed Requirements R2 and R3 and notes it is up to the entity to determine when it becomes aware of the condition upon which performance is measured. Change made.</p>
Seminole Electric Cooperative, Inc.	No	<p>Requirements R2 and R3 appear to require the reporting of trips due to UNSTABLE power swings. Seminole feels that a better mechanism for collecting information on unstable power swings is through NERC Section 1600 data requests, not via a Standard. Requirements R2 and R3 utilize the term "identifying." Can the SDT add language in the application guidelines that clarifies that "identifying" means "making a determination," as the term identifying is somewhat unclear to Seminole.</p> <p><b>Response:</b> The standard drafting team has removed the previous Requirements R2 and R3 (Transmission Owner and Generator Owner) that required notification to the Planning Coordinator in, Requirement R1, of Element trips due to stable or unstable power swings. In deleting Requirements R2 and R3, the standard drafting team revised</p>

<sup>15</sup> Protection System Misoperation Identification and Correction.

Organization	Yes or No	Question 3 Comment
		<p>Requirement R4 (now Requirement R2) for load-responsive relays to be evaluated under two conditions:</p> <ul style="list-style-type: none"> <li>Notification of an Element pursuant to Requirement R1 where the evaluation of the Element has not been performed in the last five calendar years, or</li> <li>Becoming aware of an Element that tripped in response to a stable or unstable power swing.</li> </ul> <p>The standard drafting team has provided supporting detail on the second bullet in the Guidelines and Technical Basis under the heading “Becoming Aware of an Element That Tripped in Response to a Power Swing” on how an entity would “become aware.” Changes made.</p>
Xcel Energy	No	<p>The Measures M2 &amp; M3 do not match the R2 &amp; R3 requirements. The measures only require that the TO and GO have evidence of the identification of elements, but do not require evidence of notification of identified Elements to the PC.</p> <p>The VSLs for R2 &amp; R3 classify it as a Severe VSL if the TO or GO fails to identify an Element in accordance with R2 &amp; R3. However, the way R2 &amp; R3 are written, there is no requirement for the TO or GO to identify anything. As the requirements are currently written, the only requirement is that the PC is notified within 30 calendar days of identification of an Element meeting the criteria. If a TO or GO does not identify an Element, they can never be in violation of R2 or R3 as written. Further, if there is no requirement for identification of Elements meeting R2 or R3 criteria, it is not clear what the starting point is for determining the 30 day notification period. How is the official date of identification of an Element pursuant to R2 &amp; R3 determined? And how is it officially documented for use in establishing PC notification due date in determining the severity of the violation?</p> <p>It is unclear what action the PC is going to take, upon notification of the identification of an Element meeting R2 &amp; R3 criteria, beyond adding the Element to the R1 list for future years that will be provided to the TO and GO. If that is the only resulting action,</p>

Organization	Yes or No	Question 3 Comment
		<p>the 30 day notification of the PC or the &lt;10 day overdue Lower VSL, &lt;20 day overdue Moderate VSL, &lt;30 day overdue High VSL or &gt;30 day overdue Severe VSL do not seem to align. R4 directs the TO and GO to analyze the Elements within 12 calendar months of identifying the Element pursuant to R2 or R3. If the only action taken by the PC is to add the Element to the R1 list for future years, it would seem to be just as effective from a reliability perspective to give the TO and GO up to the next calendar year to notify the PC about R2 &amp; R3 identified elements and to align the R2 &amp; R3 VSL notification timeframes with those allowed for the PC to TO/GO notifications in R1.</p> <p><b>Response:</b> The standard drafting team has removed the previous Requirements R2 and R3 (Transmission Owner and Generator Owner) that required notification to the Planning Coordinator, in Requirement R1, of Element trips due to stable or unstable power swings, thus eliminating the connection with PRC-004.<sup>16</sup> In deleting Requirements R2 and R3, the standard drafting team revised Requirement R4 (now Requirement R2) for load-responsive relays to be evaluated under two conditions:</p> <p>Notification of an Element pursuant to Requirement R1 where the evaluation of the Element has not been performed in the last five calendar years, or</p> <p>Becoming aware of an Element that tripped in response to a stable or unstable power swing.</p> <p>The standard drafting team has provided supporting detail on the second bullet in the Guidelines and Technical Basis under the heading “Becoming Aware of an Element That Tripped in Response to a Power Swing” on how an entity would “become aware.” Changes made.</p> <p>The standard drafting team has revised the standard such that Requirement R1, Criterion 5 has been eliminated, along with Requirements R2 and R3. Change made.</p>

<sup>16</sup> Protection System Misoperation Identification and Correction.

Organization	Yes or No	Question 3 Comment
		<p>The standard drafting team removed Requirements R2 and R3 and notes it is up to the entity to determine when it becomes aware of the condition upon which performance is measured. Change made.</p>
Wisconsin Electric	No	<p>: We take issue with this requirement.</p> <p>First, it will be difficult or impossible for the Generator Owner (GO) to comply with. The requirement in R3 is to notify the Planning Coordinator of an Element that trips due to a stable or unstable power swing during an actual system Disturbance due to the operation of its load-responsive protective relays. Without dynamic disturbance recording (DDR), it may not be possible to determine that the relay tripped due to a power swing. The GO is not required to have (DDR) capability for every generator. Note that DDR will only be required by the future PRC-002 standard for a subset of generators, not all of them. The most that a GO may be able to do is to say that a generator relay may have operated for a power swing, especially when the Generator Owner does not own or operate the connected transmission system.</p> <p><b>Response:</b> The standard drafting team contends that PRC-026-1 does not require an entity to determine whether an Element tripped due to a power swing. This is accomplished in the revision to Requirement R2 (previously Requirement R4) that when an entity “becomes aware” it would evaluate the relay(s). The identification of a power swing that causes a BES Element trip could be determined through an entity’s Protection System analysis process (e.g., PRC-004<sup>17</sup>), event analysis review by the entity, region, or NERC.</p> <p>The standard drafting team removed Requirements R2 and R3 and notes it is up to the entity to determine when it becomes aware of the condition upon which performance is measured. Change made.</p> <p>Second, if an unstable power swing passes through the generator or generator step-up transformer, the generator SHOULD trip in order to prevent or limit possible damage.</p>

<sup>17</sup> Protection System Misoperation Identification and Correction.

Organization	Yes or No	Question 3 Comment
		<p>The generator out-of-step relay is used for this purpose, and it does not appear that this standard will allow the necessary settings on the Device 78 element to properly protect the generator. Common industry settings for the 78 out-of-step function do not appear to be possible based on the Application Guidelines in the draft standard. For these reasons, we believe that this requirement should be removed. If it is retained, then the scope of the applicability to generators should be limited to those generators where DDR will be required per the future PRC-002.</p> <p><b>Response:</b> Requirement R2 (previously R4) ensures that the Protection System will be evaluated after tripping for an unstable power swing to ensure that the Protection System is expected to not trip for a stable power swing. The Protection System is not precluded from tripping in response to an unstable power swing. The standard drafting team contends that any out-of-step tripping requirements would be identified independent of this standard and, if required, would need to remain in service. Examples have been added to the Guidelines and Technical Basis to illustrate an entity complying with the standard while using out-of-step trip relaying.</p>
City of Tallahassee	No	<p>R2 and R3 require TOs and GOs, respectively, to notify their Planning Coordinator within 30 days of identifying any Element that trips due to a power swing during a system disturbance due to the operation of load-responsive protective relays. PRC-026-1, as drafted, will have consequences with respect to an entity's implementation of a different standard: PRC-004-3 - Protection System Misoperation Identification and Correction - see <a href="http://www.nerc.com/pa/Stand/Reliability%20Standards/PRC-004-3.pdf">http://www.nerc.com/pa/Stand/Reliability%20Standards/PRC-004-3.pdf</a>. NERC has filed PRC-004-3 with FERC for approval.</p> <p>In summary, PRC-004-3 requires each operation of an interrupting device to be evaluated to determine whether a Misoperation occurred. If such a determination is made, the Protection System owner must investigate the occurrence and either</p> <p>(a) provide a declaration that a cause could not be determined or</p> <p>(b) if a cause is determined, develop and implement a Corrective Action Plan (CAP) or explain why corrective actions are beyond its control or would not improve</p>

Organization	Yes or No	Question 3 Comment
		<p>reliability.PRC-004-3 does not require any action with regard to Element trips that are not Misoperations, i.e., “correct operations.” We understand that a Protection System owner would need some documentation to make the distinction between a correct operation and a Misoperation. However, in order to be fully compliant with PRC-026-1 R2 and R3, every Element that trips due to the operation of a load-responsive relay must be evaluated by the entity to determine whether or not the trip was due to a power swing.</p> <p>As discussed on the September 18 webinar on PRC-026-1, the phrase “system Disturbance” has same meaning as the NERC Glossary term for “Disturbance.” In other words, “system” is unnecessary. In addition, a “Fault” was stated to be a “Disturbance.” Therefore, every operation of a load-responsive relay due to a Fault must be examined under PRC-026-1 to identify whether or not the Element tripped due to a power swing.</p> <ul style="list-style-type: none"> <li>o If an Elements trips due to a Misoperation, the Misoperation would be investigated under PRC-004-3, and if it was caused by a power swing that could easily be reported under PRC-026-1 as a result of the Protection System owner’s compliance with PRC-004-3.</li> </ul> <p>Requiring all correct operations be affirmatively evaluated by the Element owner to determine whether they are attributable to a power swing would only “make work” for both the Element owners and their auditors, and the added effort would not improve reliability. Therefore, we propose that the scope of R2 and R3 for correct operations be reduced to a subset of events that are reported to NERC under EOP-004-2 - Event Reporting - see <a href="http://www.nerc.com/pa/Stand/Reliability%20Standards/EOP-004-2.pdf">http://www.nerc.com/pa/Stand/Reliability%20Standards/EOP-004-2.pdf</a>. For example, the Disturbances evaluated in PRC-026-1 for correct operations could be limited to some of the events and associated thresholds listed in EOP-004 - Attachment 1. We believe reasonable events would include:</p> <ul style="list-style-type: none"> <li>o Automatic firm load shedding on p. 9</li> <li>o Loss of firm load (preferably limited to non-weather related load loss) on p. 10</li> <li>o System separation (islanding) on p.10</li> </ul>

Organization	Yes or No	Question 3 Comment
		<p>o Generation loss on p.10,</p> <p>o Complete loss of off-site power to a nuclear plant on p. 10, and</p> <p>o Transmission loss on p.11.</p> <p>To couple the two standards together, NERC, which receives event reports under EOP-004-2, would need to notify the applicable TOs and GOs under PRC-026-1 of the time frame of each event. This would allow the Element owners to evaluate whether any Element trips that occurred during the event and which were correct operations were associated with a power swing.</p> <p><b>Response:</b> The standard drafting team has removed the previous Requirements R2 and R3 (Transmission Owner and Generator Owner) that required notification to the Planning Coordinator, in Requirement R1, of Element trips due to stable or unstable power swings. In deleting Requirements R2 and R3, the standard drafting team revised Requirement R4 (now Requirement R2) for load-responsive relays to be evaluated under two conditions:</p> <p>Notification of an Element pursuant to Requirement R1 where the evaluation of the Element has not been performed in the last five calendar years, or</p> <p>Becoming aware of an Element that tripped in response to a stable or unstable power swing.</p> <p>The standard drafting team has provided supporting detail on the second bullet in the Guidelines and Technical Basis under the heading “Becoming Aware of an Element That Tripped in Response to a Power Swing” on how an entity would “become aware.” Changes made.</p> <p>The standard drafting team made revisions to the standard which eliminated the term “Disturbance” as defined by the <i>Glossary of Terms Used in NERC Reliability Standards</i>.</p>
ISO New England	No	Although splitting the requirement into two adds clarity, what was the underlying uncertainty that this is intended to address? R4 continues to be a combined TO/GO



Organization	Yes or No	Question 3 Comment
		<p>requirement that was not split. We ask whether the same uncertainty exists for R4 (previously R3) and should it also be split?</p> <p><b>Response:</b> The standard drafting team notes that the previous splitting of the Draft 1 Requirement into the Draft 2, Requirements R2 and R3 was intended for clarifying that the “islanding” criteria was only related to the Transmission Owner. The evaluation of load-responsive protective relays under the new Requirement R2 (previously Requirement R4) applies to both the Generator Owner and Transmission Owner in evaluating the 120 degree separation angle.</p>
Kansas City Power & Light	No	<p>A trip during a stable power swing is a mis-operation and is covered in PRC-004. A trip during an unstable power swing is an intended result and not applicable to this standard. We suggest removing these two requirements.</p> <p><b>Response:</b> The standard drafting team thanks you for your comment and notes that Requirements R2 and R3 have been removed and changes were made to the previous R4 (now Requirement R2) to address other comments and concerns. Change made.</p> <p>This Requirement ensures that the Protection System will be evaluated after tripping for an unstable power swing to ensure that the Protection System is expected to not trip for a stable power swing. The Protection System is not precluded from tripping in response to an unstable power swing.</p>
Pepco Holdings Inc.	No	<p>The 30 day time line provided for Requirement R2 in the standard to determine if an element operated due to either of the Criteria provided seems aggressive. The shortest amount of time we have to determine if a protective relaying scheme mis-operated under current quarterly reporting requirements for PRC-004 is 60 days. It would make sense if the timeline for this standard was adjusted to match.</p> <p>In addition, the requirement as written does not seem to differentiate if this level of analysis is required for the operation of all in-scope protective relaying schemes or just those that were determined to mis-operated. Requiring this level of study for all in-</p>

Organization	Yes or No	Question 3 Comment
		<p>scope protective relaying schemes would seem to provide a tremendous compliance burden to the Transmission Owners.</p> <p><b>Response:</b> The standard drafting team has removed the previous Requirements R2 and R3 (Transmission Owner and Generator Owner) that required notification to the Planning Coordinator, in Requirement R1, of Element trips due to stable or unstable power swings. In deleting Requirements R2 and R3, the standard drafting team revised Requirement R4 (now Requirement R2) for load-responsive relays to be evaluated under two conditions:</p> <p>Notification of an Element pursuant to Requirement R1 where the evaluation of the Element has not been performed in the last five calendar years, or</p> <p>Becoming aware of an Element that tripped in response to a stable or unstable power swing.</p> <p>The standard drafting team has provided supporting detail on the second bullet in the Guidelines and Technical Basis under the heading “Becoming Aware of an Element That Tripped in Response to a Power Swing” on how an entity would “become aware.” Changes made.</p>
CPS Energy	No	<p>In general, support PSEG comments.</p> <p><b>Response:</b> The standard drafting team thanks you for participating, please see the responses to Public Service Enterprise Group.</p>
Nebraska Public Power District (NPPD)	No	<p>Both R2 and R3 requirements appear to take a “wait and see” approach rather than a proactive approach. This doesn’t seem practical when maintaining the reliable operation of the BES. We recommend elimination of both R2 and R3. Additionally, R2 states that the TO would need to identify “an Element that forms the boundary of an island during an actual system Disturbance due to the operation of its load-responsive protective relays.” This type of event would be very complex and would likely include many contingencies. Thus the statement seems too general and all-encompassing. We feel this reliability function might be better served by the Planning Coordinator(s) or</p>

Organization	Yes or No	Question 3 Comment
		<p>Reliability Entity facilitating an event analysis where better decisions and recommendations can be made, given their wide-area view and awareness of reliability issues. If a relay did trip on OOS for a stable power swing, the likelihood of it being part of a larger event or a misoperation is high. If it were a misoperation, it would then be addressed in another standard or event analysis process. As noted above it seems R2 and R3 are better served by existing processes or standards.</p> <p><b>Response:</b> The standard drafting team has removed the previous Requirements R2 and R3 (Transmission Owner and Generator Owner) that required notification to the Planning Coordinator, in Requirement R1, of Element trips due to stable or unstable power swings. In deleting Requirements R2 and R3, the standard drafting team revised Requirement R4 (now Requirement R2) for load-responsive relays to be evaluated under two conditions:</p> <p>Notification of an Element pursuant to Requirement R1 where the evaluation of the Element has not been performed in the last five calendar years, or</p> <p>Becoming aware of an Element that tripped in response to a stable or unstable power swing.</p> <p>The standard drafting team has provided supporting detail on the second bullet in the Guidelines and Technical Basis under the heading “Becoming Aware of an Element That Tripped in Response to a Power Swing” on how an entity would “become aware.” Changes made.</p>
Ameren	No	<p>Ameren adopts the following comment submitted by PSEG.</p> <p>R2 and R3 require TOs and GOs, respectively, to notify their Planning Coordinator within 30 days of identifying any Element that trips due to a power swing during a system disturbance due to the operation of load-responsive protective relays. PRC-026-1, as drafted, will have consequences with respect to an entity’s implementation of a different standard: PRC-004-3 - Protection System Misoperation Identification and</p>

Organization	Yes or No	Question 3 Comment
		<p>Correction - see <a href="http://www.nerc.com/pa/Stand/Reliability%20Standards/PRC-004-3.pdf">http://www.nerc.com/pa/Stand/Reliability%20Standards/PRC-004-3.pdf</a>. NERC has filed PRC-004-3 with FERC for approval.</p> <p>In summary, PRC-004-3 requires each operation of an interrupting device to be evaluated to determine whether a Misoperation occurred. If such a determination is made, the Protection System owner must investigate the occurrence and either</p> <p>(a) provide a declaration that a cause could not be determined or</p> <p>(b) if a cause is determined, develop and implement a Corrective Action Plan (CAP) or explain why corrective actions are beyond its control or would not improve reliability.</p> <p>PRC-004-3 does not require any action with regard to Element trips that are not Misoperations, i.e., “correct operations.” We understand that a Protection System owner would need some documentation to make the distinction between a correct operation and a Misoperation. However, in order to be fully compliant with PRC-026-1 R2 and R3, every Element that trips due to the operation of a load-responsive relay must be evaluated by the entity to determine whether or not the trip was due to a power swing.</p> <p>As discussed on the September 18 webinar on PRC-026-1, the phrase “system Disturbance” has same meaning as the NERC Glossary term for “Disturbance.” In other words, “system” is unnecessary. In addition, a “Fault” was stated to be a “Disturbance.” Therefore, every operation of a load-responsive relay due to a Fault must be examined under PRC-026-1 to identify whether or not the Element tripped due to a power swing.</p> <p>o If an Elements trips due to a Misoperation, the Misoperation would be investigated under PRC-004-3, and if it was caused by a power swing that could easily be reported under PRC-026-1 as a result of the Protection System owner’s compliance with PRC-004-3.</p> <p>Requiring all correct operations be affirmatively evaluated by the Element owner to determine whether they are attributable to a power swing would only “make work” for both the Element owners and their auditors, and the added effort would not improve reliability. Therefore, we propose that the scope of R2 and R3 for correct operations be</p>

Organization	Yes or No	Question 3 Comment
		<p>reduced to a subset of events that are reported to NERC under EOP-004-2 - Event Reporting - see <a href="http://www.nerc.com/pa/Stand/Reliability%20Standards/EOP-004-2.pdf">http://www.nerc.com/pa/Stand/Reliability%20Standards/EOP-004-2.pdf</a>. For example, the Disturbances evaluated in PRC-026-1 for correct operations could be limited to some of the events and associated thresholds listed in EOP-004 - Attachment 1. We believe reasonable events would include:</p> <ul style="list-style-type: none"> <li>o Automatic firm load shedding on p. 9</li> <li>o Loss of firm load (preferably limited to non-weather related load loss) on p. 10</li> <li>o System separation (islanding) on p.10</li> <li>o Generation loss on p.10,</li> <li>o Complete loss of off-site power to a nuclear plant on p. 10, and</li> <li>o Transmission loss on p.11.</li> </ul> <p>To couple the two standards together, NERC, which receives event reports under EOP-004-2, would need to notify the applicable TOs and GOs under PRC-026-1 of the time frame of each event. This would allow the Element owners to evaluate whether any Element trips that occurred during the event and which were correct operations were associated with a power swing.</p> <p><b>Response:</b> The standard drafting team has removed the previous Requirements R2 and R3 (Transmission Owner and Generator Owner) that required notification to the Planning Coordinator, in Requirement R1, of Element trips due to stable or unstable power swings. In deleting Requirements R2 and R3, the standard drafting team revised Requirement R4 (now Requirement R2) for load-responsive relays to be evaluated under two conditions:</p> <p>Notification of an Element pursuant to Requirement R1 where the evaluation of the Element has not been performed in the last five calendar years, or</p> <p>Becoming aware of an Element that tripped in response to a stable or unstable power swing.</p>

Organization	Yes or No	Question 3 Comment
		<p>The standard drafting team has provided supporting detail on the second bullet in the Guidelines and Technical Basis under the heading “Becoming Aware of an Element That Tripped in Response to a Power Swing” on how an entity would “become aware.” Changes made.</p> <p>The standard drafting team made revisions to the standard which eliminated the term “Disturbance” as defined by the <i>Glossary of Terms Used in NERC Reliability Standards</i>.</p>
CenterPoint Energy	No	<p>CenterPoint Energy recommends additional clarification be provided for identifying and the reporting, or not reporting, of Elements that trip from power swings during system disturbances. We believe certain tripping should be excluded, such as, when reconnecting islands and during black start restoration. We suggest the following sentence be added to Requirement R1, Criterion 1: “Notification shall not be provided if an Element trips from a power swing that occurs during operator-initiated switching to reconnect islands, to restore load during Black Start activities, or to synchronize a generating unit to the system”. In addition, it may be needed to clarify that tripping of Elements from voltage or frequency oscillations due to power system stabilizer issues are not to be reported.</p> <p><b>Response:</b> The standard drafting team has revised Requirement R4 (now Requirement R2) to require the Generator Owner and Transmission Owner to evaluate its load-responsive protective relays applied at the terminals of an Element that trips upon “becoming aware of an Element that tripped in response to a stable or unstable power swing.” The standard drafting team has provided supporting detail on the second bullet in the Guidelines and Technical Basis on how an entity would “become aware.”</p> <p>The standard drafting team concluded exclusions for system restoration or black-starting should not be provided because it could be detrimental to reliability. Any Element that tripped in response to a stable or unstable power swing must be addressed, especially involving restoration and black-starting because those are conditions where power swings would be expected and it is critical that load-responsive protective relays are secure for stable power swings.</p>

Organization	Yes or No	Question 3 Comment
Consumers Energy Company	No	<p>R2 and R3 require modification to provide clarity in how the Owner will determine if any given trip is due to a swing. Without specific guidance on how to identify and document when a swing occurs and whether that swing caused a trip, we do not believe we are able to comply with R2 or R3. For instance, if an Owner only has electromechanical relays on a terminal, and does not own the other terminal(s) of that element, how is it to determine the impedance trajectory and whether or not that trajectory was a swing or a fault?</p> <p><b>Response:</b> The standard drafting team has removed the previous Requirements R2 and R3 (Transmission Owner and Generator Owner) that required notification to the Planning Coordinator, in Requirement R1, of Element trips due to stable or unstable power swings. In deleting Requirements R2 and R3, the standard drafting team revised Requirement R4 (now Requirement R2) for load-responsive relays to be evaluated under two conditions:</p> <p>Notification of an Element pursuant to Requirement R1 where the evaluation of the Element has not been performed in the last five calendar years, or</p> <p>Becoming aware of an Element that tripped in response to a stable or unstable power swing.</p> <p>The standard drafting team has provided supporting detail on the second bullet in the Guidelines and Technical Basis under the heading “Becoming Aware of an Element That Tripped in Response to a Power Swing” on how an entity would “become aware.” Changes made.</p>
Northeast Power Coordinating Council	Yes	<p>Comments regarding requirements R2 and R3 can be found in the response to Question 8.</p> <p><b>Response:</b> The standard drafting team thanks you for your comment, please see response in Question 8.</p> <p>Splitting requirement R2 into two requirements adds clarity.</p>

Organization	Yes or No	Question 3 Comment
		<p><b>Response:</b> The standard drafting team thanks you for your comment and notes that Requirements R2 and R3 have been removed and changes were made to the previous R4 (now Requirement R2) to address other comments and concerns. Change made.</p>
Arizona Public Service Co	Yes	
Southern Company: Southern Company Services, Inc.; Alabama Power Company; Georgia Power Company; Gulf Power Company; Mississippi Power Company; Southern Company Generation; Southern Company Generation and Energy Marketing	Yes	<p>Since the criteria is not completely the same for the TO and GO, splitting the previous R2 into a new R2 and new R3 was a good move.</p> <p><b>Response:</b> The standard drafting team thanks you for your comment and notes that Requirements R2 and R3 have been removed and changes were made to the previous R4 (now Requirement R2) to address other comments and concerns. Change made.</p>
Duke Energy	Yes	
JEA	Yes	
DTE Electric Co.	Yes	
FirstEnergy Corp.	Yes	<p>Regarding R3, as a Generator Owner in a deregulated / competitive environment, we still have a concern about being held accountable for events for which we are unaware - power swings or Disturbances on the system (Criteria 1) - due to FERC Code of Conduct separation with the regulated system. We are not aware of system events. We realize, however, that R3 says, "... within 30 calendar days of identifying ..."; the concern simply</p>



Organization	Yes or No	Question 3 Comment
		<p>relates to the level of responsibility placed on the GO to “identify” tripping of load-responsive relays caused by “... a stable or unstable power swing during an actual system Disturbance ...”.</p> <p><b>Response:</b> The standard drafting team has removed the previous Requirements R2 and R3 (Transmission Owner and Generator Owner) that required notification to the Planning Coordinator, in Requirement R1, of Element trips due to stable or unstable power swings. In deleting Requirements R2 and R3, the standard drafting team revised Requirement R4 (now Requirement R2) for load-responsive relays to be evaluated under two conditions:</p> <p>Notification of an Element pursuant to Requirement R1 where the evaluation of the Element has not been performed in the last five calendar years, or</p> <p>Becoming aware of an Element that tripped in response to a stable or unstable power swing.</p> <p>The standard drafting team has provided supporting detail on the second bullet in the Guidelines and Technical Basis under the heading “Becoming Aware of an Element That Tripped in Response to a Power Swing” on how an entity would “become aware.” Changes made.</p>
Tennessee Valley Authority	Yes	
Seattle City Light	Yes	
ACES Standards Collaborators	Yes	<p>(1) We agree with splitting the requirements because the GO simply is not privy to the same information as the TO to identify island boundaries. However, it is reasonable for the GO to work with the TO and TOP to determine the cause of the relay operations to be from a stable power swing.</p>

Organization	Yes or No	Question 3 Comment
		<p><b>Response:</b> The standard drafting team thanks you for your comment and notes that Requirements R2 and R3 have been removed and changes were made to the previous R4 (now Requirement R2) to address other comments and concerns. Change made.</p> <p>(2) We believe the time horizons for both requirements R2 and R3 need to be modified. Both are currently long-term planning which is one year or longer into the future. Since this is an evaluation of actual events, we believe the Operations Assessment time horizon is more accurate.</p> <p><b>Response:</b> The standard drafting team removed Requirements R2 and R3; therefore, the issue is no longer present. Change made.</p> <p>(3) Why is tripping from unstable power swings included in these two requirements? Relays should trip due to unstable power swings. The FERC directive compelled NERC to develop a standard that requires protection systems to be able to differentiate between stable power swings and faults. The directive did not require NERC to specifically address unstable powers swings. We recommend removing unstable power swings from both R2 and R3.</p> <p><b>Response:</b> It is important to note that this standard does not require that entities assess Protection System performance during unstable swings and does not require entities to prevent tripping in response to unstable swings. Such requirements would exceed the directive stated in the Federal Energy Regulatory Commission (FERC) Order No. 733. This standard focuses on the identification of Elements by the Planning Coordinator (Requirement R1) and Elements where the Generator Owner or Transmission Owner becomes aware of an Element that tripped in response to a stable or unstable power swing (Draft 3, Requirement R2, 2<sup>nd</sup> bullet). Requirement R1 and R2 (2<sup>nd</sup> bullet) is a screen to identify Elements that are subject to the Requirements of the standard.</p> <p>The FERC Order No. 733 directive is perceived as broad and overreaching and could require all relays to be capable of differentiating between stable power swings and</p>

Organization	Yes or No	Question 3 Comment
		<p>faults. This standard’s focused approach is based on the PSRPS Report,<sup>18</sup> recommending “...lines that have tripped due to power swings during system disturbances...” as one of the ways to focus the evaluation. Based on feedback from the contributors to the PSRPS Report, that recommendation does not exclude unstable power swings. Furthermore, it is reasonable to assume that an Element that experiences an unstable swing (in either a simulation or reality) is likely to experience large stable power swings for less severe disturbances (that are probably more likely to occur). Thus, the standard drafting team concluded that addressing Protection Systems for Elements that tripped due to unstable power swings provides a reliability benefit. No change made.</p>
Bonneville Power Administration	Yes	
Oncor Electric Delivery LLC	Yes	
Entergy Services, Inc.	Yes	
American Electric Power	Yes	
Independent Electricity System Operator	Yes	
Luminant Generation Company, LLC	Yes	
Idaho Power	Yes	

<sup>18</sup> NERC System Protection and Control Subcommittee, *Protection System Response to Power Swings*, August 2013: [http://www.nerc.com/comm/PC/System%20Protection%20and%20Control%20Subcommittee%20SPCS%2020/SPCS%20Power%20Swing%20Report\\_Final\\_20131015.pdf](http://www.nerc.com/comm/PC/System%20Protection%20and%20Control%20Subcommittee%20SPCS%2020/SPCS%20Power%20Swing%20Report_Final_20131015.pdf)

Organization	Yes or No	Question 3 Comment
Tacoma Power	Yes	
ITC	Yes	
Texas Reliability Entity	Yes	<p>While Texas RE agrees with splitting the previous Requirement R2 into Requirement R2 for the Transmission Owner (TO) and Requirement R3 for the Generator Owner (GO) for clarity, we have concerns regarding the stated time horizon. Requirement R2 states that the TO shall notify the PC within 30 calendar days of elements that trip due to an actual disturbance, but the time horizon for this requirement is Long-term Planning (which is a planning horizon of one year or longer.) Texas RE suggests that the time horizon should be Operations Planning. Requirement R3 states that the GO shall notify the PC within 30 calendar days of elements that trip due to an actual disturbance, but the time horizon for this requirement is Long-term Planning (which is a planning horizon of one year or longer.) Texas RE suggests that the time horizon should be Operations Planning.</p> <p><b>Response:</b> The standard drafting team removed Requirements R2 and R3; therefore, the issue is no longer present. Change made.</p>
Hydro One	Yes	
Hydro One	Yes	
Manitoba Hydro	Yes	
Lower Colorado River Authority	Yes	<p>The splitting of requirement for GO and TO was good. It would be more clear if R2 &amp; R3 can directly refer to the protective elements being addressed in Attachment A are the elements to look into when power swings (stable/unstable) occurs. Also, listing some particular in events that power swings would happen can be helpful.</p> <p><b>Response:</b> The standard drafting team has removed the previous Requirements R2 and R3 (Transmission Owner and Generator Owner) that required notification to the</p>

Organization	Yes or No	Question 3 Comment
		<p>Planning Coordinator, in Requirement R1, of Element trips due to stable or unstable power swings. In deleting Requirements R2 and R3, the standard drafting team revised Requirement R4 (now Requirement R2) for load-responsive relays to be evaluated under two conditions:</p> <p>Notification of an Element pursuant to Requirement R1 where the evaluation of the Element has not been performed in the last five calendar years, or</p> <p>Becoming aware of an Element that tripped in response to a stable or unstable power swing.</p> <p>The standard drafting team has provided supporting detail on the second bullet in the Guidelines and Technical Basis under the heading “Becoming Aware of an Element That Tripped in Response to a Power Swing” on how an entity would “become aware.” Changes made.</p> <p>Additionally, the 2<sup>nd</sup> bullet is not intended to provide the entity specific exclusions to having to evaluate load-responsive protective relays in PRC-026-1 – Attachment A.</p>
American Transmission Company, LLC	Yes	
Georgia Transmission Corporation	Yes	
Tri-State Generation and Transmission Association, Inc.	Yes	
Public Service Enterprise Group		<p>This question is a duplicate of the prior question. The response below answers Q3 in the unofficial comment form.</p> <p>R2 and R3 require TOs and GOs, respectively, to notify their Planning Coordinator within 30 days of identifying any Element that trips due to a power swing during a system</p>

Organization	Yes or No	Question 3 Comment
		<p>disturbance due to the operation of load-responsive protective relays. PRC-026-1, as drafted, will have consequences with respect to an entity’s implementation of a different standard: PRC-004-3 - Protection System Misoperation Identification and Correction - see <a href="http://www.nerc.com/pa/Stand/Reliability%20Standards/PRC-004-3.pdf">http://www.nerc.com/pa/Stand/Reliability%20Standards/PRC-004-3.pdf</a>. NERC has filed PRC-004-3 with FERC for approval.</p> <p>In summary, PRC-004-3 requires each operation of an interrupting device to be evaluated to determine whether a Misoperation occurred. If such a determination is made, the Protection System owner must investigate the occurrence and either</p> <p>(a) provide a declaration that a cause could not be determined or</p> <p>(b) if a cause is determined, develop and implement a Corrective Action Plan (CAP) or explain why corrective actions are beyond its control or would not improve reliability.</p> <p>PRC-004-3 does not require any action with regard to Element trips that are not Misoperations, i.e., “correct operations.” We understand that a Protection System owner would need some documentation to make the distinction between a correct operation and a Misoperation. However, in order to be fully compliant with PRC-026-1 R2 and R3, every Element that trips due to the operation of a load-responsive relay must be evaluated by the entity to determine whether or not the trip was due to a power swing.</p> <p>As discussed on the September 18 webinar on PRC-026-1, the phrase “system Disturbance” has same meaning as the NERC Glossary term for “Disturbance.” In other words, “system” is unnecessary. In addition, a “Fault” was stated to be a “Disturbance.” Therefore, every operation of a load-responsive relay due to a Fault must be examined under PRC-026-1 to identify whether or not the Element tripped due to a power swing.</p> <p>o If an Elements trips due to a Misoperation, the Misoperation would be investigated under PRC-004-3, and if it was caused by a power swing that could easily be reported under PRC-026-1 as a result of the Protection System owner’s compliance with PRC-004-3.</p>

Organization	Yes or No	Question 3 Comment
		<p>Requiring all correct operations be affirmatively evaluated by the Element owner to determine whether they are attributable to a power swing would only “make work” for both the Element owners and their auditors, and the added effort would not improve reliability. Therefore, we propose that the scope of R2 and R3 for correct operations be reduced to a subset of events that are reported to NERC under EOP-004-2 - Event Reporting - see <a href="http://www.nerc.com/pa/Stand/Reliability%20Standards/EOP-004-2.pdf">http://www.nerc.com/pa/Stand/Reliability%20Standards/EOP-004-2.pdf</a>. For example, the Disturbances evaluated in PRC-026-1 for correct operations could be limited to some of the events and associated thresholds listed in EOP-004 - Attachment 1. We believe reasonable events would include:</p> <ul style="list-style-type: none"> <li>o Automatic firm load shedding on p. 9</li> <li>o Loss of firm load (preferably limited to non-weather related load loss) on p. 10</li> <li>o System separation (islanding) on p.10</li> <li>o Generation loss on p.10,</li> <li>o Complete loss of off-site power to a nuclear plant on p. 10, and</li> <li>o Transmission loss on p.11</li> </ul> <p>To couple the two standards together, NERC, which receives event reports under EOP-004-2, would need to notify the applicable TOs and GOs under PRC-026-1 of the time frame of each event. This would allow the Element owners to evaluate whether any Element trips that occurred during the event and which were correct operations were associated with a power swing.</p> <p><b>Response:</b> The standard drafting team has removed the previous Requirements R2 and R3 (Transmission Owner and Generator Owner) that required notification to the Planning Coordinator, in Requirement R1, of Element trips due to stable or unstable power swings. In deleting Requirements R2 and R3, the standard drafting team revised Requirement R4 (now Requirement R2) for load-responsive relays to be evaluated under two conditions:</p>

Organization	Yes or No	Question 3 Comment
		<p>Notification of an Element pursuant to Requirement R1 where the evaluation of the Element has not been performed in the last five calendar years, or</p> <p>Becoming aware of an Element that tripped in response to a stable or unstable power swing.</p> <p>The standard drafting team has provided supporting detail on the second bullet in the Guidelines and Technical Basis under the heading “Becoming Aware of an Element That Tripped in Response to a Power Swing” on how an entity would “become aware.” Changes made.</p> <p>The standard drafting team made revisions to the standard which eliminated the term “Disturbance” as defined by the <i>Glossary of Terms Used in NERC Reliability Standards</i>.</p>
Arizona Public Service	Yes	



4. **Requirement R4 (previously R3) contained multiple activities (e.g., demonstrate, develop a Corrective Action Plan, obtain agreement) and was ambiguous. Do you agree that the revision to Requirement R4 now provides a clearer understanding of what is required by the Generator Owner and Transmission Owner for an identified Element? Note: The Criterion is now found in PRC-026-1 – Attachment B, Criteria A and B. If not, please explain why the Requirement is not clear.**

**Summary Consideration:** Seventy percent of entities commenting agree that the revision to Draft 2, Requirement R4 (now Draft 3, Requirement R2) provides a clearer understanding of what is required by the Generator Owner and Transmission Owner for an identified Element.

There were five minor themes of comments that resulted in a revision to the Standard. First, One comment supported by eight individuals noted that the PRC-026-1 – Attachment B criteria appeared to be part of the Application Guidelines due to the page header. This was an editorial error and has been corrected to correctly include the criteria within the Standard itself. Second, three comments each from individuals requested the Standard Guidelines and Technical Basis include generator based out-of-step protection example for stable power swings. The standard drafting team provided an example. Third, one comment supported by five individuals requested that the re-evaluation period checking load-responsive protective relays against the PRC-026-1 – Attachment B criteria be extended from three to five years. The standard drafting team agreed that the BES would not be expected to change significantly during five years and revised the Requirement to allow a five-year re-evaluation period. Fourth, one comment supported by five individuals were concerned that the Guidelines and Technical Basis was not adequate. The standard drafting team added additional information to improve clarity on applying the PRC-026-1 – Attachment B criteria. Fifth, two comments each from individuals revealed that Draft 2 had an unintended circumstance in that an entity could skip the re-evaluation for an actual event if it had previously evaluated its load-responsive protective relays for a BES Element within the re-evaluation time frame. The standard drafting team agreed that it was important to re-evaluate the load-responsive protective relays for a BES Element for every actual BES Element trip due to stable or unstable power swings regardless of the frequency. The revisions made to Draft 3, Requirement R2 (previously Draft 2, Requirement R4) based on other comments have addressed these problems.

The following summarizes four comment themes that did not result in a change to the Standard. First, four comments represented by 40 individuals commented (includes Questions 1-8) that they would like more flexibility over the criteria in PRC-026-1 – Attachment B. The standard drafting team maintains that the method provided in the PRC-026-1 – Attachment B criteria is well documented, easily implemented, and provides a consistent method for determining a relay's susceptibility to tripping for stable power swings. Requiring Planning Coordinators and possibly Transmission Planners to run additional stability studies to determine a relay's susceptibility to tripping for a stable power swing will be more time consuming than applying the PRC-026-1 – Attachment B criteria. Further, the selected contingency study cases for stability analysis may not produce results to adequately ascertain a relay's susceptibility to tripping for a stable power swing.

Second, three comments represented by 35 individuals suggested removing “full” from the phrase “full calendar months.” The standard drafting team disagreed because comments to Draft 1 requested clarification on calendar months and using full make it clear that partial months are not considered in the time frame.

Third, one comment supported by 12 individuals requested that the evaluation time period begin upon receipt of the system impedance data from other entities. The standard drafting team did not agree because the Draft 3, Requirement R2 provides sufficient time to obtain such information, if not already on hand.

Fourth, one comment supported by an individual commented that the Guidelines and Technical Basis does not cover all the load-responsive protective relays in PRC-026-1 protection schemes and configurations. The standard drafting team responded that PRC-026-1 – Attachment B criteria applies to load-responsive protective relays irrespective of the type of protective scheme to which they are applied.

Organization	Yes or No	Question 4 Comment
Southern Company; Southern Company Services, Inc.; Alabama Power Company; Georgia Power Company; Gulf Power Company; Mississippi Power Company; Southern Company Generation; Southern Company Generation and Energy Marketing	No	<p>Is the Criteria a single page (page 17) or is it pages 17-73?</p> <p><b>Response:</b> The standard drafting team corrected the page headers to correctly associate the Attachments A and B with the standard and not the Guidelines and Technical Basis. Change made.</p> <p>The text in the rationale should be included in the Criteria paragraph so that there is no doubt what the evaluation is supposed to demonstrate.</p> <p><b>Response:</b> The standard drafting team revised the Criteria A paragraph to provide additional clarity on what the entity must achieve. Change made.</p> <p>The previous draft (R3) presentation of the demonstration, CAP development, and PC/TP/RC communication was easier to understand just what was expected of the GO and TO.</p> <p><b>Response:</b> The standard drafting team made revisions to the standard based on previous comments and identified problems with the approach in Requirement R3 (Draft 1). The standard drafting team believes that Draft 3 will provide additional clarity over both Drafts 1 and 2. No change made.</p>

Organization	Yes or No	Question 4 Comment
PPL NERC Registered Affiliates	No	<p>R4 should state that the 12-month clock for GOs begins when the TO provides the system impedance data necessary to perform studies, if the GO requests this information from the TO.</p> <p><b>Response:</b> The standard drafting team contends that 12 months is sufficient for evaluating relays (and obtaining other data) based on the conditions that start the time period for the Requirement which are when the entity is notified of an Element or becomes aware of a stable or unstable power swing. No change made.</p> <p>Also, the reference to, “full calendar months,” in R4 and Att. B should be changed to just, “calendar months,” to prevent confusion.</p> <p><b>Response:</b> The standard drafting team uses the clarifier “full” to be clear that partial months are not counted. For example, if the starting point is in the middle of a calendar month, the entity will have until the end of the last month of the stated period.</p>
Florida Municipal Power Agency	No	<p>See comments in response to Question 8 related to Applicability and responsibility for various requirements.</p> <p><b>Response:</b> The standard drafting team thanks you for your comment, please see response in Question 8.</p>
DTE Electric Co.	No	<p>R4 is clearer in general terms, however, the Criterion and related Guidelines and Technical Basis do not cover all the various relay scheme configurations that may apply. Since specific criteria must be evaluated, the concern is that relay scheme configurations not discussed may result in an incorrect evaluation.</p> <p><b>Response:</b> The standard drafting team notes that Attachment B applies to load-responsive protective relays irrespective of the type of protective scheme to which they are applied. No change made.</p>
FirstEnergy Corp.	No	<p>Attachment B, Criteria A and B might be clearer to a Protection Design Engineer, but are not likely clear to typical compliance personnel.</p>

Organization	Yes or No	Question 4 Comment
		<p><b>Response:</b> The standard drafting team contends the standard is written so that the performance under the requirements are clear to protection engineering staff that have the expertise to understand the application. Based upon the Measures provided in the Requirements, compliance staff should be able collaborate with their subject matter experts to determine correct and appropriate evidence for compliance. No change made.</p>
Tennessee Valley Authority	No	<p>While an improvement over the previous draft, we believe the time interval for consideration of previous evaluations should be extended to the prior five calendar years.</p> <p><b>Response:</b> Requirement R2 (formerly R4) requires the Generator Owner and Transmission Owner evaluate its load-responsive protective relays on an identified Element by the Planning Coordinator pursuant to Requirement R1, initially and thereafter, where the evaluation has not been performed in the last five (previously three) calendar years. Change made.</p> <p>We also would prefer to see more flexibility in the standard to allow entities to use their preferred methods (not strictly adhering to Attachment B criteria) for determining if a line is likely to trip during a stable power swing.</p> <p><b>Response:</b> The standard drafting team maintains that the method provided in the Criteria of Attachment B is well documented and easily implemented. Additionally, it provides a consistent method for determining a relay’s susceptibility to tripping for stable power swings. Requiring Planning Coordinators or Transmission Planners to run additional stability studies to determine a relay’s susceptibility to tripping for a stable power swing will be more time consuming than applying the Criteria in Attachment B. Further, the contingencies assessed may not be severe enough to adequately ascertain a relay’s susceptibility to tripping for a stable power swing. No change made.</p>
SPP Standards Review Group	No	<p>What is the difference between ‘12 full calendar months’ and ‘12-calendar months’? Delete the ‘full’ in Requirement R4.</p>

Organization	Yes or No	Question 4 Comment
		<p><b>Response:</b> The standard drafting team uses the clarifier “full” to be clear that partial months are not counted. For example, if the starting point is in the middle of a calendar month, the entity will have until the end of the last month of the stated period.</p> <p>In the 3rd line of Requirement R4, change ‘Requirement’ to ‘Requirements’.</p> <p><b>Response:</b> The standard drafting team has revised Requirement R4 (now Requirement R2) such that this issue is resolved. Change made.</p> <p>Refer to our comments in Question #2 as to why we don’t agree with the revisions.</p> <p><b>Response:</b> The standard drafting team thanks you for your comment, please see response in Question 2.</p>
Xcel Energy	No	<p>We are generally supportive of the revisions to R4 but offer the following observation.</p> <p>We believe that the way R4 is currently written, an Entity would be allowed to not evaluate an Element’s load responsive relays if they had been evaluated in the past three calendar years even if the Element was identified within the last 12 calendar months per R2 or R3 to have tripped in response to a stable power swing. For example, if an element tripped in January 2015 due to a stable power swing, the R4 analysis is performed and corrective action taken per R5 and R6. If the device trips again in 2016 due to a stable power swing, it would appear that there was a problem with the 2015 analysis. But the way R4 is written, the entity would be exempt from performing any analysis or taking any further action until 2018. We do not believe this is the drafting team’s intent.</p> <p><b>Response:</b> The standard drafting team thanks you for this keen observation and believes that the revisions made to Requirement R4 (now Requirement R2) address this and other concerns raised in comments. The restructuring of Requirement R4 (now Requirement R2) will require the Generator Owner and Transmission Owner to re-evaluate the load-responsive protective relay should another event occur.</p>
Luminant Generation Company, LLC	No	Luminant agrees that Criteria A (Attachment B) provides a method for determining a relay setting to minimize unnecessary trips due to a stable power swing; however,

Organization	Yes or No	Question 4 Comment
		<p>Luminant recommends that the generation application section include an out-of-step relay example for stable power swings.</p> <p><b>Response:</b> The standard drafting team has provided an out-of-step example in the Guidelines and Technical Basis. Change made.</p> <p>Luminant also recommends removal of unstable power swings from the requirement based on the same comments in question 2.</p> <p><b>Response:</b> It is important to note that this standard does not require that entities assess Protection System performance during unstable swings and does not require entities to prevent tripping in response to unstable swings. Such requirements would exceed the directive stated in the Federal Energy Regulatory Commission (FERC) Order No. 733. This standard focuses on the identification of Elements by the Planning Coordinator (Requirement R1) and Elements where the Generator Owner or Transmission Owner becomes aware of an Element that tripped in response to a stable or unstable power swing (Draft 3, Requirement R2, 2<sup>nd</sup> bullet). Requirement R1 and R2 (2<sup>nd</sup> bullet) is a screen to identify Elements that are subject to the Requirements of the standard.</p> <p>The FERC Order No. 733 directive is perceived as broad and overreaching and could require all relays to be capable of differentiating between stable power swings and faults. This standard’s focused approach is based on the PSRPS Report,<sup>19</sup> recommending “...lines that have tripped due to power swings during system disturbances...” as one of the ways to focus the evaluation. Based on feedback from the contributors to the PSRPS Report, that recommendation does not exclude unstable power swings. Furthermore, it is reasonable to assume that an Element that experiences an unstable swing (in either a simulation or reality) is likely to experience large stable power swings for less severe disturbances (that are probably more likely to occur). Thus, the standard drafting team</p>

<sup>19</sup> NERC System Protection and Control Subcommittee, *Protection System Response to Power Swings*, August 2013: [http://www.nerc.com/comm/PC/System%20Protection%20and%20Control%20Subcommittee%20SPCS%2020/SPCS%20Power%20Swing%20Report\\_Final\\_20131015.pdf](http://www.nerc.com/comm/PC/System%20Protection%20and%20Control%20Subcommittee%20SPCS%2020/SPCS%20Power%20Swing%20Report_Final_20131015.pdf)

Organization	Yes or No	Question 4 Comment
		concluded that addressing Protection Systems for Elements that tripped due to unstable power swings provides a reliability benefit. No change made.
Wisconsin Electric	No	<p>The limitations imposed in the Application Guidelines will not allow a Generator Owner to set an out-of-step relay to properly protect the generator, using commonly applied settings such as for single blinder schemes, and possibly other out-of-step schemes. The settings must be able to detect a power swing in the generator or GSU transformer, which appears to violate the setting limits as in the example of Figure 20.</p> <p><b>Response:</b> The standard drafting team has provided an out-of-step example in the Guidelines and Technical Basis. Change made.</p>
Kansas City Power & Light	No	<p>Attachment A includes Out-of-step tripping. This condition is an unstable power swing and should not be included in the standard. The standard should allow protection relays and philosophies to protect the equipment first and foremost. The requirement not to trip during a stable power swing should be reviewed and considered, but not mandatory if deemed that protection will be sacrificed.</p> <p><b>Response:</b> It is important to note that this standard does not require that entities assess Protection System performance during unstable swings and does not require entities to prevent tripping in response to unstable swings. Such requirements would exceed the directive stated in the Federal Energy Regulatory Commission (FERC) Order No. 733. This standard focuses on the identification of Elements by the Planning Coordinator (Requirement R1) and Elements where the Generator Owner or Transmission Owner becomes aware of an Element that tripped in response to a stable or unstable power swing (Draft 3, Requirement R2, 2<sup>nd</sup> bullet). Requirement R1 and R2 (2<sup>nd</sup> bullet) is a screen to identify Elements that are subject to the Requirements of the standard.</p> <p>The FERC Order No. 733 directive is perceived as broad and overreaching and could require all relays to be capable of differentiating between stable power swings and</p>

Organization	Yes or No	Question 4 Comment
		<p>faults. This standard’s focused approach is based on the PSRPS Report,<sup>20</sup> recommending “...lines that have tripped due to power swings during system disturbances...” as one of the ways to focus the evaluation. Based on feedback from the contributors to the PSRPS Report, that recommendation does not exclude unstable power swings. Furthermore, it is reasonable to assume that an Element that experiences an unstable swing (in either a simulation or reality) is likely to experience large stable power swings for less severe disturbances (that are probably more likely to occur). Thus, the standard drafting team concluded that addressing Protection Systems for Elements that tripped due to unstable power swings provides a reliability benefit. No change made.</p>
CPS Energy	No	<p>In general, support Luminant comments.</p> <p><b>Response:</b> The standard drafting team thanks you for your comment, please see response to Luminant.</p>
Lower Colorado River Authority	No	<p>see comments for R4 under application guidelines.</p> <p><b>Response:</b> The standard drafting team thanks you for your comment, please see response in Question 6 concerning the Application Guidelines.</p>
Northeast Power Coordinating Council	Yes	<p>Requirement R4 continues to be a combined TO/GO requirement. For clarity, R4 should also be split into two requirements--one to address the GO obligations by applicable requirement, another to address the TO obligations by applicable requirement.</p> <p><b>Response:</b> The standard drafting team notes that the previous splitting of the Draft 1 Requirement into the Draft 2, Requirements R2 and R3 was intended for clarifying that the “islanding” criteria was only related to the Transmission Owner. The evaluation of load-responsive protective relays under the new Requirement R2 (previously</p>

<sup>20</sup> NERC System Protection and Control Subcommittee, *Protection System Response to Power Swings*, August 2013: [http://www.nerc.com/comm/PC/System%20Protection%20and%20Control%20Subcommittee%20SPCS%2020/SPCS%20Power%20Swing%20Report\\_Final\\_20131015.pdf](http://www.nerc.com/comm/PC/System%20Protection%20and%20Control%20Subcommittee%20SPCS%2020/SPCS%20Power%20Swing%20Report_Final_20131015.pdf)



Organization	Yes or No	Question 4 Comment
		Requirement R4) applies to both the Generator Owner and Transmission Owner in evaluating the 120 degree separation angle.
Arizona Public Service Co	Yes	
Puget Sound Energy	Yes	
Colorado Springs Utilities	Yes	
Duke Energy	Yes	
ISO RTO Council Standards Review Committee	Yes	<p>The SRC agrees that the revisions have provided clarity; however, notes the inconsistency within the standard regarding describing GO and TO requirements separately in Requirements R2 and R3.</p> <p><b>Response:</b> The standard drafting team notes that the previous splitting of the Draft 1 Requirement into the Draft 2, Requirements R2 and R3 was intended for clarifying that the “islanding” criteria was only related to the Transmission Owner. The evaluation of load-responsive protective relays under the new Requirement R2 (previously Requirement R4) applies to both the Generator Owner and Transmission Owner in evaluating the 120 degree separation angle.</p>
Dominion	Yes	
JEA	Yes	
Seattle City Light	Yes	<p>Seattle appreciates the effort of the drafting team to separate auditable activities into an individual requirement or subrequirement rather than blending them together.</p> <p><b>Response:</b> The standard drafting team thanks you for your comment.</p>

Organization	Yes or No	Question 4 Comment
ACES Standards Collaborators	Yes	We agree the requirement is much clearer. <b>Response:</b> The standard drafting team thanks you for your comment.
Bonneville Power Administration	Yes	BPA agrees that Attachment B is an improvement; however, it could be better. It appears that the only way to verify compliance is through a graphical comparison of the relay characteristic and a lens characteristic that is described in the Application Guidelines. The Application Guidelines give one example of calculating six sample points on the lens characteristic. BPA was able to work our way through the example, but it was somewhat difficult and required lots of reading between the lines. BPA requests more explicit explanations of what is expected to show compliance and how to develop the lens characteristic. <b>Response:</b> More detailed point calculations have been added to the Application Guidelines to show more point-by-point calculations of the lens (see Figures 5a, 15d, 15h, and 15i). Change made.
Oncor Electric Delivery LLC	Yes	
Public Service Enterprise Group	Yes	
Entergy Services, Inc.	Yes	
American Electric Power	Yes	
Independent Electricity System Operator	Yes	
City of Tallahassee	Yes	

Organization	Yes or No	Question 4 Comment
Idaho Power	Yes	
ISO New England	Yes	
Pepco Holdings Inc.	Yes	The requirement as written in the latest draft version of the standard is clear on what actions must be taken. The 12 month timeline is reasonable.  <b>Response:</b> The standard drafting team thanks you for your comment.
Nebraska Public Power District (NPPD)	Yes	
Tacoma Power	Yes	
Ameren	Yes	
ITC	Yes	
Texas Reliability Entity	Yes	No comments.
Hydro One	Yes	Please refer to comments for 6.  <b>Response:</b> The standard drafting team thanks you for your comment, please see response in Question 6.
Hydro One	Yes	Refer to 6.  <b>Response:</b> The standard drafting team thanks you for your comment, please see response in Question 6.
Manitoba Hydro	Yes	

Organization	Yes or No	Question 4 Comment
American Transmission Company, LLC	Yes	
Georgia Transmission Corporation	Yes	
Tri-State Generation and Transmission Association, Inc.	Yes	
Consumers Energy Company	Yes	

5. **The new Requirement R5 (previously R4) and the new Requirement R6 address Corrective Action Plans (CAP), if any. Do you agree this is an improvement over having the development of the CAP comingled with another Requirement? If not, please explain.**

**Summary Consideration:** More than half of the entities that commented agree that Draft 2, Requirements R5 and R6 were an improvement over the previous Draft 1. The following summarizes the comments received starting with the comments that resulted in a change to the Standard and followed by a summary of comments that did not result in a change to the Standard.

There were three significant themes of comments that resulted in a revision to the Standard. First, twelve comments represented by 25 individuals were concerned that the Corrective Action Plan (CAP) was limited to only modifying the Protection System and did not provide an alternative. The standard drafting team modified the Draft 2, Requirement R5 (now Draft 3, Requirement R3) to make it clear that the development of a CAP may include; 1) modifications to the Protection System to meet the PRC-026-1 – Attachment B criteria, 2) modifications to the system configuration (e.g., splitting a bus such that the Protection System meets the PRC-026-1 – Attachment B criteria), and 3) modifications so that the Protection System is excluded under the PRC-026-1 – Attachment A criteria (e.g., modifying the Protection System so that relay functions are supervised by power swing blocking or using relay systems that are immune to power swings), while maintaining dependable fault detection and dependable out-of-step tripping (if out-of-step tripping is applied at the terminal of the BES Element).

Second, five comments supported by 35 individuals were concerned that 90 calendar days was insufficient for determining corrective actions for inclusion in a CAP. Entities are concerned that development of the necessary modifications could be very complex and take longer than 90 calendar days. The standard drafting team agreed and extended the time period for developing the CAP to six full calendar months.

Third, one comment supported by ten individuals requested that evidence retention periods be set to 12 calendar months to be consistent with the Reliability Assurance Initiative (RAI). The standard drafting team consulted with NERC staff and made the revisions.

The following summarizes four comments that did not result in a change to the standard. First, two comments represented by 25 individuals requested that the Generator Owner and Transmission Owner have a Requirement to provide notification of the status of its CAP to the Planning Coordinator. The standard drafting team disagreed because such notification is administrative and has limited reliability benefit for something entities may request on their own outside of the Standard.

Second, two comments supported by 11 individuals believed that the Draft 3, Requirement R4 (previously Draft 2, Requirement R6) to implement the CAP is administrative due to updating actions and timetables to demonstrate compliance. The standard drafting team disagreed that updating paperwork is not the intent and is not the sole source for having evidence of implementation. Updating actions and timetables are an essential part of the CAP for when the actions (i.e., tasks) that are required to remedy the problem change. Implementation may be demonstrated by providing work order showing a particular action (i.e., task) was completed, but the work order was not necessarily updated as “complete” in the CAP or tracking system.

Third, two comments supported by six individuals were concerned that a CAP could be required under both PRC-004<sup>21</sup> and this PRC-026 Standard. The standard drafting team agrees that in rare cases, the entity may be doing a CAP in both Standards. An entity may use a single CAP to demonstrate compliance with both Standards or create separate CAPs. In some cases, an entity’s CAP for resolving a Misoperation could be different from a longer term CAP for meeting the reliability purpose of PRC-026-1.

Fourth, two comments each from individuals believe that a CAP would prevent the Protection System from tripping for unstable power swings. The standard drafting team noted that the Standard does not preclude tripping for unstable power swings.

Organization	Yes or No	Question 5 Comment
Northeast Power Coordinating Council	No	A CAP is developed to correct a problem after the requirements of a standard are implemented. The Implementation Plan should address meeting the obligations of the standard’s requirements. The Implementation Plan would also address the annual identification of Elements. This would allow for the removal of requirements R5 and R6. Generator Owners and Transmission Owners need more time subsequent to the identification of load-responsive protective relays to perform a thorough evaluation. The requirement should provide at least 180 days to perform the evaluation. This will allow for a more complete response than can be obtained in 60 days. If the CAP is kept, the Generator or Transmission Owner should provide a copy of the initial Corrective Action Plan and status updates to the Planning Coordinator. The length of time an entity has to complete corrective actions should be specified. 180 calendar days is a realistic length of time.

<sup>21</sup>

Organization	Yes or No	Question 5 Comment
		<p><b>Response:</b> Thank you for your comment. The standard drafting team has extended the time for the Corrective Action Plan (CAP) development to six calendar months. The length of time to implement the CAP is included in the CAP. Change made.</p> <p>Response: The standard drafting team contends notification of the CAP has no reliability benefit and would only add to the compliance burden as an administrative function.</p>
Puget Sound Energy	No	<p>It should be recognized in the requirement that the appropriate response to a trip due to a stable power swing might be to take no action. The requirement should be amended to allow the Element owner to make a declaration that corrective action would not improve BES reliability, therefore action will not be taken, consistent with PRC-004-3, R5.</p> <p><b>Response:</b> The standard drafting team contends that all trips in response to stable power swings require the relays to be evaluated and, if required, a Corrective Action Plan (CAP) be developed so that the Protection System meets the PRC-026-1 – Attachment B criteria while maintaining dependable fault detection and dependable out-of-step tripping (if out-of-step tripping is applied at the terminal of the Element). Eliminating unnecessary future tripping of Elements in response stable power swings does improve BES reliability.</p>
Southern Company: Southern Company Services, Inc.; Alabama Power Company; Georgia Power Company; Gulf Power Company; Mississippi Power Company; Southern Company Generation; Southern	No	<p>Already discuss in Q4 comment - the requirement to develop a CAP was clear either way. The addition of the 60 day due date added more detail.</p> <p><b>Response:</b> Thank you for your comment.</p>

Organization	Yes or No	Question 5 Comment
Company Generation and Energy Marketing		
Colorado Springs Utilities	No	<p>We agree with the Public Service Electric and Gas Company comments.</p> <p><b>Response:</b> The standard drafting team thanks you for participating, please see the responses to Public Service Enterprise Group.</p>
ISO RTO Council Standards Review Committee	No	<p>We agree with consolidating the Corrective Action Plan obligations into Requirements R5 and R6. However, the SRC recommends that, for R5, Generator and Transmission Owners need more time to develop a thorough CAP that addresses identified issues with load-responsive protective relays. The requirement should provide at least 180 days to develop the Corrective Action Plan, which would will allow for a more complete and thoughtful response than can be obtained in 60 days.</p> <p><b>Response:</b> Thank you for your comment. The standard drafting team has extended the time for the Corrective Action Plan (CAP) development to six calendar months. The length of time to implement the CAP is included in the CAP. Change made.</p> <p>Also under R5, the Generator or Transmission Owner should provide a copy of the initial Corrective Action Plan and status updates to the Planning Coordinator. Right now, the requirement is open ended without the provision of Corrective Action Plan information.</p> <p><b>Response:</b> The SDT contends notification of the CAP has no reliability benefit and would only add to the compliance burden as an administrative function.</p>
Dominion	No	<p>No date is given for CAP implementation. Is it acceptable to work the CAP in with projects regardless of project execution date? (3-7 years, if no project is in place at the specific location; is it acceptable to implement the CAP once a project arises?)</p> <p><b>Response:</b> In the event that a Corrective Action Plan (CAP) is necessary based on future system conditions, the CAP can specify a time frame that does not enact changes until the actual system modifications will be made. No change made.</p>



Organization	Yes or No	Question 5 Comment
PPL NERC Registered Affiliates	No	<p>: The deadline of 60 calendar days for development of a Corrective Action Plan should be changed to six months. Many GOs do not have Protection System design expertise, and the process of making a business case for the expenditure of hiring a contractor, getting this request approved, exploring alternatives, making a technical selection and again obtaining management approval can take far more than sixty days.</p> <p><b>Response:</b> Thank you for your comment. The standard drafting team has extended the time for the Corrective Action Plan (CAP) development to six calendar months. The length of time to implement the CAP is included in the CAP. Change made.</p>
Florida Municipal Power Agency	No	<p>FMPA agrees with the separation of R5 and R6. However, R5 pre-supposes and furthermore directs that the only acceptable Corrective Action Plan is one which involves modifying the Protection System. There are a number of other ways to improve stability performance which are therefore ruled out. In fact, improving the performance to, and reducing the severity of power swings that result from a given event should be a preferential solution as it has a much wider impact on the stability and the reliability of the system. It may be true that modifications to microprocessor relay settings or even replacement of relays might be the least cost or the fastest and simplest solution, that in no way should dictate that the standard should mandate this be the only corrective action employed.</p> <p><b>Response:</b> Thank you for your comment. The standard drafting team has modified the requirement so that a Corrective Action Plan (CAP) can include any modifications that ensure that the Protection Systems meet the criteria in Attachment B. Change made.</p>
ACES Standards Collaborators	No	<p>We agree splitting the requirement into two requirements where one deals with assessing the Protection System and the other deals with developing a CAP is an improvement. However, we continue to believe the Requirement R6 is an administrative requirement that meets P81 criteria and should be removed. The only way the R6 will ever be violated is if an entity fails to update their paperwork on the CAP. How does failing to update documentation not administrative?</p>

Organization	Yes or No	Question 5 Comment
		<p><b>Response:</b> The standard drafting team intends the entity to be capable of demonstrating implementation of a Corrective Action Plan (CAP) based on evidence specified in the Measure. For example, evidence showing completion of the various actions of the CAP would demonstrate the entity’s effort toward remedying the specific problem. The updating of actions and timetables in Requirement R4 (previously Requirement R6) is not intended to specify an administrative exercise to show compliance with implementation. The updating of actions and timetables refers to the entity revising the CAP during the implementation as needed following its initial development. The standard drafting team has suggested to NERC Compliance modifications to the Reliability Standard Audit Worksheet (RSAW) in the approach section to Requirement R4 (previously Requirement R6) concerning the implementation of the CAP.</p> <p>How does ensuring the documentation is updated by enforcing penalties serve reliability? How is this consistent with RAI which is intended to refocus compliance and enforcement on those risks most important to reliability and not on documentation issues?</p> <p><b>Response:</b> The standard drafting team has revised the minimum periods to retain evidence to 12 calendar months in the Evidence Retention section to address Risk Assurance Initiative (RAI) concerns. Change made.</p>
Public Service Enterprise Group	No	<p>The requirement to develop a CAP in R5 should be amended to allow the Element owner, in lieu of a developing a CAP, to make a declaration that corrective actions would not improve BES reliability and therefore will not be taken. This is consistent with PRC-004-3, R5.</p> <p><b>Response:</b> The standard drafting team contends that all trips in response to stable power swings require the relays to be evaluated and, if required, a Corrective Action Plan (CAP) be developed so that the Protection System meets the PRC-026-1 – Attachment B criteria while maintaining dependable fault detection and dependable out-of-step tripping (if out-of-step tripping is applied at the terminal of the Element).</p>

Organization	Yes or No	Question 5 Comment
		Eliminating unnecessary future tripping of Elements in response stable power swings does improve BES reliability.
Seminole Electric Cooperative, Inc.	No	<p>Requirement R5 requires the development of a CAP. Seminole requests that the ability to submit a notification to the Entity’s RRO, stating why a CAP cannot or should not be implemented, be added to R5. Seminole reasons that there may be instances where a CAP is not possible, somewhat akin to a TFE in the CIP-world. The SDT could make the CAP exception contingent on the RRO’s approval.</p> <p><b>Response:</b> The standard drafting team contends that all trips in response to stable power swings require the relays to be evaluated and, if required, a Corrective Action Plan (CAP) be developed so that the Protection System meets the PRC-026-1 – Attachment B criteria while maintaining dependable fault detection and dependable out-of-step tripping (if out-of-step tripping is applied at the terminal of the Element). Eliminating unnecessary future tripping of Elements in response stable power swings does improve BES reliability.</p>
Independent Electricity System Operator	No	<p>The scope of the proposed standard is directed at blocking the trip for stable power swings only. However, since existing distance schemes have the ability to trip for both stable and unstable swings, the standard can be interpreted as permitting a Transmission Owner to remove both trip abilities in order to comply with this standard. Removing the trip abilities for unstable power swings may have unintended consequences, such as preventing successful self-generating islands to form, making the restoration process much more difficult. In order to prevent any unintended consequence, we suggest that Requirement 5 is modified to have the Transmission Owner consult with the Planning Coordinator for whether out-of-step protection is needed, and if so, whether out of step tripping or power swing blocking should be applied:</p> <p>R5. Each Generator Owner and Transmission Owner shall, within 60 calendar days of an evaluation that identifies load-responsive protective relays that do not meet the PRC-026-1 - Attachment B Criteria pursuant to Requirement R4, develop a Corrective Action</p>

Organization	Yes or No	Question 5 Comment
		<p>Plan (CAP) to modify the Protection System to meet the PRC-026-1 - Attachment B Criteria while maintaining dependable fault detection and dependable out-of-step tripping. (Each Generator Owner and Transmission Owner shall consult with their applicable Planning Coordinator if out of-step tripping should be applied at the terminal of the Element).</p> <p><b>Response:</b> A Corrective Action Plan (CAP), when implemented, does not preclude the relay from tripping in response to an unstable power swing. The standard drafting team contends that any out-of-step tripping requirements would be identified independent of this standard and, if required, would need to remain in service. This standard is not intended to create a requirement to prevent out-of-step tripping for unstable power swings nor to evaluate where out-of-step tripping should be applied.</p> <p>It is important to note that this standard does not require that entities assess Protection System performance during unstable swings and does not require entities to prevent tripping in response to unstable swings. Such requirements would exceed the concern stated in Order No. 733. This standard focuses on the identification of Elements by the Planning Coordinator (Requirement R1) and Elements where the Generator Owner or Transmission Owner becomes aware of an Element that tripped in response to a stable or unstable power swing (Draft 3, Requirement R2, 2<sup>nd</sup> bullet). Identification of Elements is a screen to identify Elements with load-responsive protective relays that are subject to the Requirements of the standard. No change made.</p>
Wisconsin Electric	No	<p>Similar to PRC-004-3 R5, the entity should be allowed to explain in a declaration why corrective actions would not improve BES reliability and that no further corrective actions will be taken. For overall BES reliability, It must be left to the equipment Owners to determine when relay settings which do not meet the Application Guidelines must still be used for proper equipment protection.</p> <p><b>Response:</b> The standard drafting team contends that all trips in response to stable power swings require the relays to be evaluated and, if required, a Corrective Action Plan (CAP) be developed so that the Protection System meets the PRC-026-1 –</p>

Organization	Yes or No	Question 5 Comment
		Attachment B criteria while maintaining dependable fault detection and dependable out-of-step tripping (if out-of-step tripping is applied at the terminal of the Element). Eliminating unnecessary future tripping of Elements in response stable power swings does improve BES reliability.
City of Tallahassee	No	<p>The requirement to develop a CAP in R5 should be amended to allow the Element owner, in lieu of a developing a CAP, to make a declaration that corrective actions would not improve BES reliability and therefore will not be taken. This is consistent with PRC-004-3, R5.</p> <p><b>Response:</b> The standard drafting team contends that all trips in response to stable power swings require the relays to be evaluated and, if required, a Corrective Action Plan (CAP) be developed so that the Protection System meets the PRC-026-1 – Attachment B criteria while maintaining dependable fault detection and dependable out-of-step tripping (if out-of-step tripping is applied at the terminal of the Element). Eliminating unnecessary future tripping of Elements in response stable power swings does improve BES reliability.</p>
ISO New England	No	<p>For R5, Generator and Transmission Owners need more time develop a Corrective Action Plan. The requirement should provide at least 180 days to develop the Corrective Action Plan. This will allow for a more complete and thoughtful response than can be obtained in 60 days.</p> <p><b>Response:</b> Thank you for your comment. The standard drafting team has extended the time for the Corrective Action Plan (CAP) development to six calendar months. The length of time to implement the CAP is included in the CAP. Change made.</p> <p>Also under R5, the Generator or Transmission Owner should provide a copy of the initial Corrective Action Plan and status updates to the Planning Coordinator. Right now, the requirement is open ended without the provision of Corrective Action Plan information.</p>

Organization	Yes or No	Question 5 Comment
		<p><b>Response:</b> The standard drafting team contends notification of the Corrective Action Plan (CAP) has limited reliability benefit, if any, and would only add to the compliance burden as an administrative function. No change made.</p>
Kansas City Power & Light	No	<p>Out-of-step tripping and tripping for unstable power swings are intended results. Corrective Action Plans are not needed for these events.</p> <p><b>Response:</b> A Corrective Action Plan (CAP), when implemented, does not preclude the relay from tripping in response to an unstable power swing. The standard drafting team contends that any out-of-step tripping requirements would be identified independent of this standard and, if required, would need to remain in service. There is no requirement to create a CAP to prevent tripping for unstable power swings.</p> <p>It is important to note that this standard does not require that entities assess Protection System performance during unstable swings and does not require entities to prevent tripping in response to unstable swings. Such requirements would exceed the concern stated in Order No. 733. This standard focuses on the identification of Elements by the Planning Coordinator (Requirement R1) and Elements where the Generator Owner or Transmission Owner becomes aware of an Element that tripped in response to a stable or unstable power swing (Draft 3, Requirement R2, 2<sup>nd</sup> bullet). Identification of Elements is a screen to identify Elements with load-responsive protective relays that are subject to the Requirements of the standard. No change made.</p>
CPS Energy	No	<p>In general, support PSEG comments.</p> <p><b>Response:</b> The standard drafting team thanks you for participating, please see the responses to the Public Service Enterprise Group.</p>
Ameren	No	<p>Ameren adopts the following comment submitted by PSEG.</p> <p>The requirement to develop a CAP in R5 should be amended to allow the Element owner, in lieu of a developing a CAP, to make a declaration that corrective actions would not</p>

Organization	Yes or No	Question 5 Comment
		<p>improve BES reliability and therefore will not be taken. This is consistent with PRC-004-3, R5.</p> <p><b>Response:</b> The standard drafting team contends that all trips in response to stable power swings require the relays to be evaluated and, if required, a Corrective Action Plan (CAP) be developed so that the Protection System meets the PRC-026-1 – Attachment B criteria while maintaining dependable fault detection and dependable out-of-step tripping (if out-of-step tripping is applied at the terminal of the Element). Eliminating unnecessary future tripping of Elements in response stable power swings does improve BES reliability.</p>
ITC	No	<p>A “no CAP declaration” should be added to R5. This option is necessary when enabling power swing blocking affects the BES reliability. An example is for a Slow Trip - During Fault, in which the high-speed protection scheme has been identified to meet the dynamic stability performance requirements of the TPL standards. As ITC stated in Draft 1, we are concerned about load/swings with subsequent phase faults which result in time-delayed tripping when power swing blocking is enabled.</p> <p><b>Response:</b> The standard drafting team contends that all trips in response to stable power swings require the relays to be evaluated and, if required, a Corrective Action Plan (CAP) be developed so that the Protection System meets the PRC-026-1 – Attachment B criteria while maintaining dependable fault detection and dependable out-of-step tripping (if out-of-step tripping is applied at the terminal of the Element). Eliminating unnecessary future tripping of Elements in response stable power swings does improve BES reliability. In cases where tripping for a fault that occurs while out-of-step blocking is enabled is a concern, then other methods may need to be considered in order to meet the criteria of Attachment B.</p>
Lower Colorado River Authority	No	<p>R5(part of the previously R3), missed the alternative options in previously R3 which allows entities owner to obtain agreement from planning coordinator, if a dependable fault detection or out of step tripping cannot be achieved.</p>

Organization	Yes or No	Question 5 Comment
		<p><b>Response:</b> The standard drafting team contends that relays that do not meet Attachment B criteria can be modified by changing relay settings or changing the Protection System to meet the criteria. Attachment B includes an alternative method to meet the criteria at a system separation angle less than 120 degrees. No change made.</p> <p>R5 in application guideline asks to “develop” and “complete” the CAP, while R5 in the standard only ask to “develop” within 60 cal day time period.</p> <p><b>Response:</b> The standard drafting team deleted the “complete” from the Guidelines and Technical Basis. Note that Requirement R5 is now Requirement R3. Change made.</p> <p>It’s ambiguous with R6 in the standard which asks to “implement” the CAP without any specific time period. And i assume this is to allow the “implementation” to be occur during next available plant outage.</p> <p><b>Response:</b> The Corrective Action Plan (CAP) has its own timetable and set of actions that are determined by the entity. The work necessary under the CAP may vary greatly depending on the work being performed; therefore, the standard drafting team has not specified any time frames. No change made.</p>
CenterPoint Energy	No	<p>CenterPoint Energy recommends that requirements for Corrective Action Plans (CAP) be removed in the draft PRC-026-1 standard. The operation of a Protection System during a non-fault condition due to a stable power swing would be a reportable Misoperation under PRC-004. Both the current enforceable version of PRC-004 and the one under development require a CAP for a Misoperation. Consistent with one of the recommendations from the NERC Industry Experts initiative, CenterPoint Energy believes that there should not be duplicative requirements in NERC Reliability Standards.</p> <p><b>Response:</b> The Corrective Action Plan (CAP) would be required under PRC-004<sup>22</sup> for an identified Misoperation; however, for an Element that trips due to a stable or unstable power swing whether or not it was a Misoperation, a CAP would be required under PRC-</p>

<sup>22</sup> Protection System Misoperation Identification and Correction.



Organization	Yes or No	Question 5 Comment
		026-1 if the entity determined that its load-responsive protective relays did not meet PRC-026-1 – Attachment B criteria. No change made.
Arizona Public Service Co	Yes	
Duke Energy	Yes	<p>Duke Energy agrees that this an improvement from the previous draft. However, we seek guidance or clarification on the boundaries between PRC-026-1 and PRC-004-3. When Misoperations occur due to a stable power swing, a CAP is required to be developed pursuant to R5 of PRC-004-3. Would the evaluation and, if needed, Corrective Action Plan from PRC-026-1 R4 through R6 be acceptable as use for the CAP required in PRC-004-3 R5?</p> <p><b>Response:</b> A Corrective Action Plan (CAP) would be required pursuant to PRC-004<sup>23</sup> if a Misoperation has occurred. If the CAP is developed so that the Protection System meets the PRC-026-1 – Attachment B criteria while maintaining dependable fault detection and dependable out-of-step tripping (if out-of-step tripping is applied at the terminal of the Element), then it could also be used for PRC-026-1. It is up to the discretion of the entity as to how it demonstrates compliance with the CAP requirements in each standard.</p>
JEA	Yes	
DTE Electric Co.	Yes	
FirstEnergy Corp.	Yes	<p>Assuming a situation results in the need for a CAP, what is the purpose of stating that dependable fault detection (and out-of-step tripping if applied) shall be maintained while developing the CAP?</p> <p>Maintenance and testing of protection is covered in PRC-005, and any failure of existing protection is addressed by PRC-004. Why is there further need to address maintaining</p>

<sup>23</sup> Protection System Misoperation Identification and Correction.

Organization	Yes or No	Question 5 Comment
		<p>existing protection, and how is such a requirement measured in the context of PRC-026-1?</p> <p>Also, what is the anticipated mechanism for tracking and reporting progress on a CAP?</p> <p><b>Response:</b> The standard drafting team included the clause “dependable fault detection (and out-of-step tripping if applied)” to express that certain protection may not simply be disabled to comply with this standard.</p> <p>The standard requires the development and implementation of a Corrective Action Plan (CAP) to, by definition, which is “[a] list of actions and an associated timetable for implementation to remedy a specific problem.” In this case, to ensure that the Protection System meets the PRC-026-1 – Attachment B criteria while maintaining dependable fault detection and dependable out-of-step tripping (if out-of-step tripping is applied at the terminal of the Element).</p> <p>There is no tracking and reporting of a Corrective Action Plan (CAP) progress to other parties. The entity must demonstrate implementation of its CAP(s). No change made.</p>
Tennessee Valley Authority	Yes	
Seattle City Light	Yes	<p>Seattle appreciates the effort of the drafting team to separate auditable activities into an individual requirement or subrequirement rather than blending them together.</p> <p><b>Response:</b> Thank you for your support.</p>
Bonneville Power Administration	Yes	
Oncor Electric Delivery LLC	Yes	
Entergy Services, Inc.	Yes	

Organization	Yes or No	Question 5 Comment
American Electric Power	Yes	
Xcel Energy	Yes	<p>The VSLs for R4 and R5 seem inconsistent. Entities are given 12 calendar months to perform an analysis with VSLs of increasing severity for being &lt;30, &lt;60, &lt;90, and &gt; 90 days past due. They are given 60 days to develop a CAP following completion of an evaluation that determines the need for a protection system modification to meet PRC-026-1 Attachment B criteria, and with an R5 VSL of increasing severity for being &lt;10, &lt;20, &lt;30 or &gt;30 days past due in the development of a CAP. Given the 12 month leeway on the completion of analysis following identification of the Element and the only 60 day leeway on CAP development, why would an entity sign off an R4 analysis as complete for an element requiring a protection system modification prior to the 12 month deadline, essentially starting the 60 day clock on the CAP development R5 requirement? We recommend that all R4 analysis completion and R5 CAP development timeframes be based on the calendar months from the original date of identification of the susceptible Element and that the same &lt;30 day, &lt;60 day, &lt;90 day and &gt;90 day increments be used both R4 and R5 VSLs. This approach would eliminate any potential benefit from delaying the officially acknowledged date of completion of the R4 analysis and not have any effect on the final R5 max CAP development timeframe (ie. months since initial Element identification) allowable by the standard.</p> <p><b>Response:</b> Thank you for your comment. The standard drafting team considered your suggested approach, but contends that the current approach is more concise.</p> <p>The standard drafting team has extended the time for the Corrective Action Plan (CAP) development to six calendar months. The length of time to implement the CAP is included in the CAP. Change made.</p>
Luminant Generation Company, LLC	Yes	
Idaho Power	Yes	

Organization	Yes or No	Question 5 Comment
Pepco Holdings Inc.	Yes	<p>The requirement as written in the latest draft version of the standard is clear on what actions must be taken. The 12 month timeline is reasonable.</p> <p><b>Response:</b> The SDT thanks you for your support.</p>
Nebraska Public Power District (NPPD)	Yes	<p>We agree that separation of the CAP requirement is an improvement; however, we feel there should be a caveat to this requirement. The standard as written could result in reduced sensitivity of fault detection settings, which would interfere with “maintaining dependable fault detection”. We believe there should be an option to maintain our ability to operate the BES in a reliable manner and still remain in compliance with R5. This requirement seems like double-jeopardy.</p> <p><b>Response:</b> The standard drafting team contends that all trips in response to stable power swings require the relays to be evaluated and, if required, a Corrective Action Plan (CAP) be developed so that the Protection System meets the PRC-026-1 – Attachment B criteria while maintaining dependable fault detection and dependable out-of-step tripping (if out-of-step tripping is applied at the terminal of the Element). Eliminating unnecessary future tripping of Elements in response stable power swings does improve BES reliability.</p>
Tacoma Power	Yes	
Texas Reliability Entity	Yes	No comments.
Hydro One	Yes	
Hydro One	Yes	
Manitoba Hydro	Yes	
American Transmission Company, LLC	Yes	

Organization	Yes or No	Question 5 Comment
Georgia Transmission Corporation	Yes	
Tri-State Generation and Transmission Association, Inc.	Yes	<p>The requirement to develop a CAP in R5 should be edited to allow the owner to make a declaration that corrective actions would not improve BES reliability if that is the case and therefore action will not be taken. This is consistent with PRC-004-3, R5.</p> <p><b>Response:</b> The standard drafting team contends that all trips in response to stable power swings require the relays to be evaluated and, if required, a Corrective Action Plan (CAP) be developed so that the Protection System meets the PRC-026-1 – Attachment B criteria while maintaining dependable fault detection and dependable out-of-step tripping (if out-of-step tripping is applied at the terminal of the Element). Eliminating unnecessary future tripping of Elements in response stable power swings does improve BES reliability.</p>

- 6. Does the “Application Guidelines and Technical Basis” provide sufficient guidance, basis for approach, and examples to support performance of the requirements? If not, please provide specific detail that would improve the Guidelines and Technical Basis.

**Summary Consideration:** Slightly less than half of the entities that commented agreed that the Application Guidelines and Technical Basis” provide sufficient guidance, basis for approach, and examples to support performance of the Requirements. The following summarizes the comments received starting with the comments that resulted in a change to the Standard and followed by a summary of comments that did not result in a change to the Standard.

There were two significant themes of comments that resulted in a revision to the Standard. First, twelve comments supported by 38 individuals requested clarifications in Guidelines and Technical Basis. The standard drafting team provided additional discussion, figures, and tables. Second, three comments represented by 24 individuals suggested a number of editorial, formatting, and style edits for the Guidelines and Technical Basis. The standard drafting team implemented corrections those items that were errors and consistent with the NERC style guide for writing.

There were two minor themes of comments that did not result in a revision to the Standard. First, one comment supported by six individuals questioned the Standard’s exclusion of relays with a time delay greater than 15 cycles with regard to slip rates. The standard drafting team noted that a time delay of 15 cycles was chosen because it equates to a conservatively low, stable power swing slip rate of 0.67 Hz. As a consequence of using this slip rate and corresponding time delay, most zone 2 relays are excluded. Second, one comment represented by five individuals had general questions or observations. The standard drafting team provided informative feedback to questions and observations.

Organization	Yes or No	Question 6 Comment
Southern Company; Southern Company Services, Inc.; Alabama Power Company; Georgia Power Company; Gulf Power Company; Mississippi	No	The calculations, requiring the extent of material provided in the application guide to explain, appear to be quite complex and difficult.  Is the SDT open to considering an alternative method of evaluation? It is proposed that GO or TO give relay settings to the entity with the transient analysis modeling tool (TP/PC), and that entity determine if the GO/TO relay settings need to be modified

Organization	Yes or No	Question 6 Comment
Power Company; Southern Company Generation; Southern Company Generation and Energy Marketing		based on the power swing characteristics and simulation results for the area being reviewed.  <b>Response:</b> The standard drafting team maintains that the method provided in the Criteria of Attachment B is well documented and easily implemented. Additionally, it provides a consistent method for determining a relay’s susceptibility to tripping for stable power swings. Requiring Planning Coordinators or Transmission Planners to run additional stability studies to determine a relay’s susceptibility to tripping for a stable power swing will be more time consuming than applying the Criteria in Attachment B. Further, the contingencies assessed may not be severe enough to adequately ascertain a relay’s susceptibility to tripping for a stable power swing. Also, additional “communication” Requirements would have to be added to the Standard requiring the Generator Owner or Transmission Owner to provide relay settings to the Planning Coordinator or Transmission Planner and requiring the Planning Coordinator or Transmission Planner to provide the results of their studies back to the Generator Owner or Transmission Owner. Each of these new Requirements would need time horizons giving each applicable entity a limited amount of time to communicate the pertinent data. These new Requirements would add additional compliance burden to the Applicable Entities. No change made.
Dominion	No	Under Criterion R4, ‘Exclusion of Time Based Load-Responsive Protective Relays,’ the calculations here are ambiguous. PRC-026-1 Attachment A explicitly states we are to evaluate protective functions listed with a delay of 15 cycles or less; however, there is small section outlining the need to calculate what sort of delays should be evaluated under different slip frequencies. Adding the ‘Exclusion of Time Based Load-Responsive Protective Relays’ section is counter-productive in its current context. Dominion suggests that the SDT revise the section to make it more understandable or remove it.  No section discusses slip frequencies ranges. The WECC experiences 0.25-0.28 Hz north-south oscillations, ERCOT experiences 0.6 Hz north-south and 0.3 Hz east-west, Tennessee to Maine experiences 0.2 Hz oscillations, but Tennessee to Missouri experiences 0.7 Hz oscillations. Roughly 0.01 to 0.8 Hz oscillations are associated with

Organization	Yes or No	Question 6 Comment
		<p>wide area oscillations, but 3.0 to 10 Hz oscillations are associated with FACTS devices that may cause wide or local. What is the acceptable range of oscillations this standard is meant to cover?</p> <p><b>Response:</b> The “Exclusion of Time Based Load-Responsive Protective Relays” section in the Application Guidelines is a technical justification for excluding load-responsive protective relays that have a time delay of 15 cycles or greater. It does not require an Entity to evaluate relay time delays for varying system slip rates. Various relay time delays were evaluated for an expected worst case stable power swing that enters a mho characteristic at a system angle of 90 degrees and turns back around 120 degrees. The total traversal time (relay time delay) was then converted to a system slip rate for comparison purposes. The time delay of 15 cycles was chosen because it equates to a conservatively low, stable power swing slip rate of 0.67 Hz. As a consequence of using this slip rate and corresponding time delay, most zone 2 relays are excluded. The slip rate analysis was done to validate a minimum time delay that could be used to exclude certain load-responsive relay elements (e.g., zone 3 mho, zone 4 mho, phase time overcurrent, etc.), that are set with larger reaches and longer time delays. The Standard is not establishing minimum or maximum slip rate criteria that must be adhered to. The chosen time delay is not intended to cover all possible slip rates.</p>
JEA	No	<p>This standard is not necessary and we agree with the analysis of the NERC SPCS that it may have unintended consequences which could decrease the reliability of the BES.</p> <p><b>Response:</b> The standard drafting team thanks you for your comment and provided a detailed explanation in the previous Consideration of Comments<sup>24</sup> in the introductory remarks regarding the need for a standard to meet regulatory directives.</p>
Florida Municipal Power Agency	No	<p>FMPA commends the drafting team on the amount of material that has been developed to support the Application of this standard. The various examples used in the</p>

<sup>24</sup> [http://www.nerc.com/pa/Stand/Project%202010133%20Phase%203%20of%20Relay%20Loadability%20stabl/Project\\_2010\\_13.3\\_Consideration\\_of\\_Comments\\_2014\\_08\\_22\\_to\\_Draft\\_1.pdf](http://www.nerc.com/pa/Stand/Project%202010133%20Phase%203%20of%20Relay%20Loadability%20stabl/Project_2010_13.3_Consideration_of_Comments_2014_08_22_to_Draft_1.pdf)



Organization	Yes or No	Question 6 Comment
		<p>Application Guide are generally good example scenarios. However, the focus of the Guide seems to be more on repetitive demonstration of basic equations and less on the SDT's expected interpretation of various scenarios. One full sample of all the calculations in one scenario is all that is required. Each time the equations are repeated it takes roughly 11 pages.</p> <p><b>Response:</b> The standard drafting team has left the detailed calculations for the six critical points of the lens characteristic. No change made.</p> <p>In general there are a lot of pages of basic equations and very little "guidance" within the examples. Furthermore, the examples seem to have been developed to make a supporting case for the Criteria of Attachment B but there is no true discussion of how these examples should be interpreted to support the Criteria. An easy example of this is Table 10, where the impact of the system transfer impedance on the lens characteristic is tabulated, but there is no use of that data to explain why all transfer impedances, no matter what the magnitude, should be completely ignored. The data is there, but the expectations regarding interpretation of the data are more important, and these are missing.</p> <p><b>Response:</b> More detail has been added to the Application Guidelines to better clarify the equations. Additionally, a clarifying paragraph has been added with a discussion of the data in Table 10. Change made.</p> <p>A couple of additional issues that FMPA believes should be cleaned up.</p> <ul style="list-style-type: none"> <li>o The first full paragraph of Page 28 of the Application Guidelines describes the modeling of generator reactances in stability models, but there is no segue regarding why this information was presented. Please clarify that the intent of the paragraph is to make it clear that the reactances that are used by TP's/PCs (unsaturated reactances) may not be the same reactances as the ones that are being recommended for use in the application of the criteria (saturated reactances).</li> </ul> <p><b>Response:</b> A clarifying paragraph has been added to the Application Guidelines after the paragraph mentioned above. Change made.</p>

Organization	Yes or No	Question 6 Comment
		<p>o The Application Guide makes frequent reference to “pilot zone 2 element” in the figures. Strictly speaking the figures show an example of a “distance” or “impedance” mho relay characteristic curve. The term “pilot” refers colloquially in protection to a communication assisted scheme, which may be used in conjunction with a mho characteristic or may not. The use of this term introduces confusion because Attachment A specifically excludes “pilot wire relays”, which are a specific sub-set of transmission relay that does not use a mho characteristic.</p> <p><b>Response:</b> The figures have been updated to generically refer to Pilot Zone 2 and Zone 2 impedance characteristics as “mho element characteristics.” A clarifying paragraph has also been added discussing the types of “pilot” or communications relay schemes that need to be considered. Change made.</p>
DTE Electric Co.	No	<p>While considerable discussion and examples have been provided, there are variations in relay types and schemes that are not specifically covered. Perhaps these variations could be submitted at some point for review and application guidance.</p> <p><b>Response:</b> The standard drafting team agrees that there are various relay types (e.g., mho, quadrilateral, lens, loss of field, out-of-step, over current, etc.) that must meet the criteria of this Standard. The standard drafting team attempted to illustrate the application of the criteria in PRC-026-1 – Attachment B using only the most common relay types for brevity. There are other types of relays not specifically discussed in the Application Guidelines, but the criteria in PRC-026-1 – Attachment B can be applied to them similarly.</p>
SPP Standards Review Group	No	<p>Insert a ‘to’ between ‘pursuant’ and Criterion’ in the 3rd line up from the bottom of the paragraph on Criterion 1. In the 9th line in the 1st paragraph under Criterion 4, capitalize ‘Criterion’.</p> <p>In Figures 1 and 2, change ‘Criterion five’ to ‘Criterion 5’. In the 7th line of the paragraph following Figures 1 and 2, change ‘included’ to ‘include’.</p> <p><b>Response:</b> Changes made.</p>

Organization	Yes or No	Question 6 Comment
		<p>In the 8th line of the paragraph under Requirement R4, delete 'full' and hyphenate '12-calendar'.</p> <p><b>Response:</b> The SDT is retaining the word "full." Change not made.</p> <p>In the 5th line of the 2nd paragraph under Exclusion of Time Based Load-Responsive Protective Relays, insert 'degrees' between '120' and 'before'.</p> <p><b>Response:</b> Change made.</p> <p>In the 3rd line of the paragraph immediately following Table 1, capitalize 'Zone'.</p> <p><b>Response:</b> Changes made.</p> <p>In the 15th line of the same paragraph, delete the same phrase in the parenthetical.</p> <p><b>Response:</b> The standard drafting team could not locate the source of the comment.</p> <p>In the 4th line of the paragraph following Equation (3), replace 'plus and minus' with a '+/-'.</p> <p><b>Response:</b> Change made.</p> <p>Capitalize 'Zone 2' in the captions of Figures 10, 11, 12, and 15.</p> <p><b>Response:</b> Changes made.</p> <p>In that same paragraph, capitalize 'Zone 2'.</p> <p><b>Response:</b> Change made.</p> <p>In the last line of the 2nd paragraph under Application to Generation Elements, replace 'Requirement' with 'Requirements'.</p> <p><b>Response:</b> Change made.</p> <p>Capitalize 'Zone 2' in the 1st line of Example R5a.</p> <p><b>Response:</b> Change made.</p> <p>Capitalize 'Zone 2' in the 1st line of Example R5c.</p>

Organization	Yes or No	Question 6 Comment
		<p><b>Response:</b> Changes made.</p>
Seattle City Light	No	<p>Seattle appreciates the efforts of the drafting team to provide application guidance and technical basis information and welcomes the trend towards such implementation documentation throughout the standards development process. For PRC-026, this material has improved somewhat compared to the original draft, but application of the standard remains insufficiently clear for Seattle to recommend an affirmative ballot at this time. More examples and/or a flow chart or something similar to fully delineate the steps in the process are wanted.</p> <p><b>Response:</b> Thank you for your comments. The standard drafting team has made changes to the Standard to clarify industry issues. We don't believe that the Requirements of the Standard require a flow chart. More clarifying examples have been added to the Application Guidelines.</p>
ACES Standards Collaborators	No	<p>(1) The "Application Guidelines and Technical Basis" are quite helpful and definitely do provide additional insight into the meaning of the requirements. However, we believe additional modifications are necessary.</p> <p>(2) On page 18 in the second paragraph, we do not believe the paragraph captures all of the reasons for changing the applicability of the standard. We believe that changing the applicability makes that standard consistent with the other relay loadability standards and makes the standard consistent with the functional model. These reasons are important to capture as they are more substantial than those listed.</p> <p><b>Response:</b> The standard drafting team agrees and has incorporated the change in the Introduction section. Change made.</p> <p>(3) In the Requirement R1 paragraph on page 20, please change "and other NERC Reliability Standards" to PRC-006. There are two main standards (or five depending on which version of TPL are used) that drive identification of Elements susceptible to stable power swings. They are the UFLS standards and TPL standard(s). As written, this paragraph is too open ended and could lead to confusion.</p>

Organization	Yes or No	Question 6 Comment
		<p><b>Response:</b> The standard drafting team has added a reference to PRC-006 and left the reference to “other NERC Reliability Standards” to capture future Standards that may be developed or existing Standards that may be modified. Change made.</p> <p>(4) We suggest that a diagram should be developed depicting the example in the second paragraph on page 24.</p> <p><b>Response:</b> Requirements R2 and R3 were removed and their intent (actual events) is now captured in Requirement R2 (previously Requirement R4). The paragraph referring to the formation of an island in the R2 section of the Application Guidelines has been removed. Change made.</p> <p>(5) In the “lens characteristic” examples, we suggest that annotating the figure with the actual lens point would be helpful in understanding the “lens characteristic”.</p> <p><b>Response:</b> More detailed point calculations have been added to the Application Guidelines to show more point-by-point calculations of the lens (see Figures 5a, 15d, 15h, and 15i). Change made.</p>
Bonneville Power Administration	No	<p>BPA agrees that Attachment B is an improvement; however, it could be better. It appears that the only way to verify compliance is through a graphical comparison of the relay characteristic and a lens characteristic that is described in the Application Guidelines. The Application Guidelines give one example of calculating six sample points on the lens characteristic. BPA was able to work our way through the example, but it was somewhat difficult and required lots of reading between the lines. BPA requests more explicit explanations of what is expected to show compliance and how to develop the lens characteristic.</p> <p><b>Response:</b> More detailed point calculations have been added to the Application Guidelines to show more point-by-point calculations of the lens (see Figures 5a, 15d, 15h, and 15i). Change made.</p>
Xcel Energy	No	<p>In the Application Guidelines, Criteria 1 uses the term “operating limit” and Criteria 2 uses the term “System Operating Limit” although both are identified by the existence</p>

Organization	Yes or No	Question 6 Comment
		<p>of angular stability constraints, seemingly defining the same type of operating constraint, i.e. operating limit. Xcel Energy would suggest either explaining the difference between the terms “operating limit” and “System Operating Limit”, or eliminating the potentially duplicative criterion, since a “Generator” can be an “Element”.</p> <p><b>Response:</b> The standard drafting team replaced the term “operating limit” with “System Operating Limit (SOL)” in Criterion 1 to be consistent with Criterion 2. Criterion 1 identifies generators and Elements terminating at the Transmission station associated with the generator(s), while Criterion 2 identifies transmission Elements that are monitored as part of an SOL. Change made.</p> <p>The lens calculation tool is not validated or authorized for use. Due to the hypothetical nature of the calculations, a standardized tool should be provided so that industry can achieve consistent results.</p> <p><b>Response:</b> It is each Entity’s responsibility to obtain or create necessary tools to prove compliance with NERC Standards. The Application Guidelines sufficiently document and detail the necessary calculations to prove compliance. Additionally, a sample tool has been made available on the PRC-026-1 project page to help guide entities. No change made.</p> <p>There is no requirement that the TO provide the System Equivalent to the GO. This Standard should provide communication requirements between the GO and TO, similar to the MOD series standards effective inn 2014. While this may not be necessary due to the typically amenable working relationships in a vertically integrated utility, it may be required in areas that are served by several companies.</p> <p><b>Response:</b> The standard drafting team chose not to include communication requirements between the Generator Owner and TO for the exchange of source impedance data at a given transmission interconnection point, because the standard drafting team is confident this exchange of source impedance data is already occurring outside of Reliability Standard requirements. A communication Requirement for the</p>

Organization	Yes or No	Question 6 Comment
		exchange of source impedance data would be administrative in nature, and would create additional compliance tracking burdens for both entities. No change made.
Luminant Generation Company, LLC	No	Luminant recommends that in the Generator Application section, an example of a generator out-of-step relay application for stable power swings should be provided. <b>Response:</b> A generation out-of-step relay example has been added to the Application Guidelines. Change made.
Wisconsin Electric	No	For generators, the Application Guidelines make reference to using the generator transient reactance $X'd$ . However, Tables 15 and 16 show the sub-transient reactance $X''d$ in the calculations. This appears to be a discrepancy. See also Question 3 above. <b>Response:</b> The discrepancies in Tables 15 and 16 have been corrected. Change made. See response to Question 3 above.
Kansas City Power & Light	No	The graphs seem not to match the calculations. <b>Response:</b> The detailed point calculations for all graphs have been re-checked, and one error was found in Table 17 ( $E_S/E_R = 1$ ; magnitude should be 0.194 at 201.9 degrees rather than 0.111 at 201.9 degrees.) Change made.
CPS Energy	No	In general, support Luminant comments. <b>Response:</b> A generation out-of-step relay example has been added to the Application Guidelines. Change made.
Tacoma Power	No	In the Application Guidelines, in the discussion of Figure 11, suggest changing "...thus allowing the zone 2 element to meet PRC-026-1 - Attachment B, Criteria A" to something like the following: "...thus allowing the zone 2 element to meet PRC-026-1 - Attachment B, Criterion A. However, including the transfer impedance in the calculation of the lens characteristic is not compliant with Requirement R4." Similarly,

Organization	Yes or No	Question 6 Comment
		<p>update the Figure 11 caption to indicate that the calculation is not compliant with Requirement R4.</p> <p><b>Response:</b> The suggested changes have been made. Please note that Requirement R4 is now Requirement R2.</p> <p>In the Application Guidelines, in the discussion of Requirement R5, the statement “that all actions associated with any Corrective Action Plan (CAP) developed in the previous requirement [Requirement R4]...” is incorrect. Requirement R4 does not have anything to do with a CAP.</p> <p><b>Response:</b> The lead paragraph was a leftover duplicate from a prior version of the Application Guidelines. This lead paragraph has been removed. Change made.</p>
ITC	No	<p>The R2 example of an island forming is insufficient. Suppose a line includes tapped load and a tapped generator, does this form an island if the line ends trip for a phase fault? R2 Criteria 2 does not exclude this example, therefore it should be discussed in Application Guidelines and Technical Basis.</p> <p><b>Response:</b> Requirements R2 and R3 were removed and their intent (actual events) is now captured in Requirement R2 (previously Requirement R4). The paragraph referring to the formation of an island in the R2 section of the Application Guidelines has been removed. Change made.</p>
Hydro One	No	<p>This section now provides clarity for each of the requirements in the standard. However, for Requirement 4, the “Application Guidelines and Technical Basis,” section does not provide direction on how to treat multi-terminal configurations (specifically 3-terminal). Providing guidance on how to approach multi-terminal configuration would be helpful.</p> <p><b>Response:</b> A 3-terminal line example has been added to the Application Guidelines. Change made.</p>



Organization	Yes or No	Question 6 Comment
Lower Colorado River Authority	No	<p>see comments for application guidelines. It would be helpful to include out of step examples for the GO and TO.</p> <p><b>Response:</b> A generation out-of-step relay example has been added to the generation section of the Application Guidelines. A transmission out-of-step trip example is shown in Figure 15 of the Application Guidelines. Change made.</p>
Tri-State Generation and Transmission Association, Inc.	No	<p>The “Exclusion of Time Based Load-Responsive Protective Relays” on p 25 indicates that time delayed Zone 2 and Zone 3 relays are intended to be excluded from this standard. However, many of the figures reference Zone 2 relay compliance or non-compliance; in particular, see Figure 10. That seems to imply that the Zone 2 relays in the example do need to comply with this standard. If we are told that time-delayed relay elements are to be excluded, does this imply that the Zone 2 relay is being used in a directional comparison blocking (DCB) scheme? If so, should that not be clearly identified? (Only Figures 3 and 12 identify the element in question as being a pilot Zone 2, and pilot could refer to may schemes that would not be impacted by extending beyond the defined impedance boundary). Similar to that example would be the use of Zone 2 relay elements to assert permission in a permissive overreaching transfer trip (POTT) scheme. It is likely that Zone 2 relay elements in a POTT scheme could extend beyond the impedance characteristic defined in Attachment B, but the only regions that would result in tripping in less than 15 cycles are the overlapping Zone 2 regions that result in POTT scheme activation, which would most likely be fully contained in the region defined in Attachment B. Tri-State believes that a statement or example clarifying that such a protection system is compliant would be beneficial to applicable entities as well as the compliance monitoring entities.</p> <p><b>Response:</b> The figures have been updated to generically refer to Pilot Zone 2 and Zone 2 impedance characteristics as “mho element characteristics.” A clarifying paragraph has also been added discussing the types of “pilot” or communications relay schemes that need to be considered. Change made.</p>

Organization	Yes or No	Question 6 Comment
Consumers Energy Company	No	<p>The revised application guidelines are very helpful, but need to be expanded to include guidance on how to comply with R2 and R3, specifically how Generator Owners and Transmission Owners are expected to determine whether a trip was due to a swing. Given the lack of guidance we have at this point, we feel we are unable to comply with R2 or R3.</p> <p><b>Response:</b> The standard drafting team contends that PRC-026-1 does not require an entity to determine whether an Element tripped due to a power swing. This is accomplished in the revision to Requirement R2 (previously Requirement R4) that when an entity “becomes aware” it would evaluate the relay(s). The identification of a power swing that causes a BES Element trip could be determined through an entity’s Protection System analysis process (e.g., PRC-004<sup>25</sup>), event analysis review by the entity, region, or NERC.</p>
Arizona Public Service Co	Yes	
Puget Sound Energy	Yes	
FirstEnergy Corp.	Yes	
Oncor Electric Delivery LLC	Yes	
Entergy Services, Inc.	Yes	
American Electric Power	Yes	

<sup>25</sup> Protection System Misoperation Identification and Correction.

Organization	Yes or No	Question 6 Comment
Independent Electricity System Operator	Yes	
Idaho Power	Yes	
ISO New England	Yes	
Pepco Holdings Inc.	Yes	
Nebraska Public Power District (NPPD)	Yes	
Ameren	Yes	
Texas Reliability Entity	Yes	No comments.
Hydro One	Yes	<p>This section now provides clarity for each of the requirements in the standard. However, for Requirement 4, the “Application Guidelines and Technical Basis,” section does not provide direction on how to treat multi-terminal configurations (specifically 3-terminal). Providing guidance on how to approach multi-terminal configuration would be helpful.</p> <p><b>Response:</b> A 3-terminal line example has been added to the Application Guidelines. Change made.</p>
Manitoba Hydro	Yes	
American Transmission Company, LLC	Yes	

Organization	Yes or No	Question 6 Comment
Colorado Springs Utilities		No Comments
Exelon Companies		<p>In the guidelines and technical basis section of the standard, a method for evaluating whether a distance element is susceptible or not is given. In the previous guidelines and technical basis, a simpler method of plotting the relay characteristic within the lens drawn at the 120 degree critical angle was also described. This method seems to have been removed from the current draft standard. This method works often for our protection schemes and requires no calculations (it is simpler and less work). The drafting team should consider putting this section back in the guidelines section to show that this method may also be used.</p> <p><b>Response:</b> A method for evaluating distance elements is provided in the Application Guidelines as shown in Figure 5 and Tables 2 – 7. It is a modified, more realistic method than the one presented in Draft 1. The illustration of the lens calculation is now only for a portion of a lens and the interior intersection with the un-equal EMF power swing trajectories. This approach is more realistic, because it accounts for the fact that the generator voltages won't be zero during a power swing. The generator voltages are varied from 0.7 to 1.0 per unit to create a realistic and adequately conservative portion of a lens against which the circle distance elements are compared to determine their susceptibility to tripping for stable power swings. The evaluation using the portion of a lens is not more work once an application tool has been developed using the formulae in the Application Guidelines. Additional clarifying examples have been included to the Application Guidelines.</p>

- 7. **The Implementation Plan for the proposed standard has been revised, based on comments, to account for factors such as the initial influx of identified Elements and ongoing burden of entities to identify Elements and re-evaluate Protection Systems. Does the implementation plan provide sufficient time for implementing the standard? If not, please provide a justification for changing the proposed implementation period and for which Requirement.**

**Summary Consideration:** Over 80 percent of the entities that commented agreed that the Implementation Plan provides sufficient time for implementing the Standard. Several commenters that disagreed with the Implementation Plan noted that 12 months is not sufficient to prepare studies under Requirement R1. The standard drafting team noted that PRC-026-1 is not requiring the preparation of any studies and only requires the use of the most recent assessments according to the Requirements. The following summarizes the comments received starting with the comments that resulted in a change to the Standard and followed by a summary of comments that did not result in a change to the Standard.

There was one significant theme that resulted in a revision to the Standard. Four comments supported by 31 individuals commented that development and implementation of the Corrective Action Plan (CAP) in Draft 2, Requirements R5 and R6 (now Draft 3, Requirements R3 and R4) should have the same implementation time frame as Draft 2, Requirement R4 (now Draft 3, Requirement R2). This is because the development and implementation of the CAP cannot be enforceable when the Requirement that causes the CAP to be developed has yet to be enforceable. The standard drafting team modified the Implementation Plan so that Draft 3, Requirements R2, R3, and R4 (previously Draft 2, Requirements R4, R5, and R6) have the same implementation period.

There one significant and one minor comment did not result in a revision to the Standard. Most significantly, two comments supported by 32 individuals believe the implementation period should be longer due to having to prepare studies. The standard drafting team noted that the preparation of new studies are not required and the Requirements use the most recent assessments. A minor theme, two comments represented by six individuals requested that Requirement R1 be increased from 12 to 24 calendar months. The standard drafting team disagreed because the Requirement relies on the most recent assessment and not the preparation of new studies.

Organization	Yes or No	Question 7 Comment
Northeast Power Coordinating Council	No	Twelve months is not adequate to prepare for this standard as written. The Drafting Team should change the Implementation Plan to 24 months.

Organization	Yes or No	Question 7 Comment
		<p>The implementation could be improved by adding when the performance of requirement R1 is due.</p> <p>Is the PC supposed to complete its R1 analysis based on the effective date of the Standard 12 months after FERC approval, or 12 months after FERC approves the Standard then the PC has to complete the study for the calendar year?</p> <p>This can be difficult depending on when FERC approves the Standard. We suggest the revision to 24 months and stating that the PC is expected to complete the identification required by R1 in the calendar year that the requirement becomes effective. This removes the concern of what month FERC approves the Standard.</p> <p><b>Response:</b> The Implementation Plan provides sufficient justification for the implementation periods and allows for 12 calendar months for the Planning Coordinator and 36 calendar months for the Generator Owner and Transmission Owner. Requirement R1 must be performed each calendar year (January-December); therefore, the Planning Coordinator must complete its notification of BES generators, transformers, and transmission line Elements to the respective Generator Owner and Transmission Owner by December 31 of each calendar year. The Implementation Plan states that the Planning Coordinator will begin its performance on the first day of a calendar year 12 calendar months following adoption or approval of the standard. For example, if the standard is approved on September 17, 2015 the 12 calendar month clock starts on the first of the following year (2016); therefore, the year in which the Planning Coordinator must be compliant with the standard will be January 1, 2017. No change made.</p>
ISO RTO Council Standards Review Committee	No	<p>The SRC notes that twelve (12) months is not adequate to prepare for this standard as written. Accordingly, it is recommended that the drafting team revise the implementation plan to allow twenty four months for implementation.</p> <p><b>Response:</b> The standard drafting team has provided additional information in the Implementation Plan document to clarify when certain activities must be implemented. Change made.</p>

Organization	Yes or No	Question 7 Comment
Florida Municipal Power Agency	No	<p>The Implementation Plan does not offer compelling evidence that the implementation date for R5 and R6, which are driven exclusively by R4, should be set at 12 months from approval while R4 is at 36 months from approval. Setting R5 and R6 earlier than R4 instead of allowing them to be parallel to R4 introduces circuitous logic as now the language of these Requirements appears to require R4 to be completed early...There does not appear to be any value in setting R5 and R6 at 12 months when there is nothing to measure compliance with them against - the implementation plan explains the 12 months to is to allow entities to develop “internal processes and procedures”, but the Requirements do not require such procedures nor are these listed in the measures.</p> <p><b>Response:</b> The standard drafting team has modified the Implementation Plan so that Requirements R3 and R4 (previously Requirements R5 and R6) have the same implementation period of R2 (previously Requirement R4). Change made.</p>
SPP Standards Review Group	No	<p>We have a concern that the Implementation Plan doesn’t reflect the changes mentioned by the drafting team in their response to our comments on Question 4 in the previous posting.</p> <p>That response states ‘The drafting team increased the Implementation Plan to three years to provide for the initial influx of identified Elements under Requirement R1. The evaluation of relays under Requirement R4 previously R3) is to be performed “within 12 full calendar months of receiving notification of an Element... where the evaluation has not been performed in the last three calendar years.” Change made’.</p> <p>We request clarification on why this change doesn’t appear in the current proposed standard and Implementation Plan.</p> <p><b>Response:</b> The standard drafting team notes that the reference to “changes made” in the previous posting related to the changes made to the Implementation Plan. In response to additional time for Requirement R1, the standard drafting team notes that studies are not required by the standard (i.e., Requirement R1). The criteria in Requirement R1 are based on existing studies (i.e., annual Planning Assessments) and that the Planning Coordinator will have minimal effort to notify the respective Generator</p>

Organization	Yes or No	Question 7 Comment
		Owner and Transmission Owner of Elements that meet the Requirement R1 criteria. No change made.
ACES Standards Collaborators	No	<p>We do believe the 36-month period of implementation for R4 is sufficient. However, we do not understand why R5 and R6 do not have the same effective date as R4. They are dependent on R4 with the “pursuant to Requirement R4” and “pursuant to Requirement R5” clauses in the requirements. To avoid the confusion associated with monitoring compliance to R5 and R6 when they cannot technically be violated, please align the effective date for R5 and R6 to R4 to avoid this confusion.</p> <p><b>Response:</b> The standard drafting team has modified the Implementation Plan so that Requirements R3 and R4 (previously Requirements R5 and R6) have the same implementation period of R2 (previously Requirement R4). Change made.</p>
ISO New England	No	<p>Twelve months is not adequate to prepare for this standard as written. The drafting team should change the implementation plan to twenty four months.</p> <p><b>Response:</b> The standard drafting team contends that a 36 calendar month implementation of Requirement R4 (now Requirement R2) provides ample time for entities to address the initial influx of identified Elements, if any. Entities should keep in mind that, for example, that Requirement R4 (now Requirement R2) allows a 12 calendar month period to evaluate load-responsive protective relays on the Element which means the entity will have nearly 48 months for completion depending on identification of the Element. No change made.</p>
NIPSCO	No	<p>We would prefer that the 12 month implementation plan for R1-R3, R5, R6 be set to 24 months; this is based on the related burden of implementing PRC-025-1.</p> <p><b>Response:</b> The standard drafting team has modified the Implementation Plan so that Requirements R3 and R4 (previously Requirements R5 and R6) have the same implementation period of R2 (previously Requirement R4). Change made.</p>



Organization	Yes or No	Question 7 Comment
Arizona Public Service Co	Yes	
Puget Sound Energy	Yes	
Southern Company: Southern Company Services, Inc.; Alabama Power Company; Georgia Power Company; Gulf Power Company; Mississippi Power Company; Southern Company Generation; Southern Company Generation and Energy Marketing	Yes	
Colorado Springs Utilities	Yes	
Duke Energy	Yes	
Dominion	Yes	<p>If R4 is a precursor for R5 and R6, R4-R6 should be included in the 36 month implementation plan.</p> <p><b>Response:</b> The standard drafting team has modified the Implementation Plan so that Requirements R3 and R4 (previously Requirements R5 and R6) have the same implementation period of R2 (previously Requirement R4). Change made.</p>
DTE Electric Co.	Yes	No comment

Organization	Yes or No	Question 7 Comment
FirstEnergy Corp.	Yes	
Oncor Electric Delivery LLC	Yes	
Public Service Enterprise Group	Yes	
Entergy Services, Inc.	Yes	
American Electric Power	Yes	
Independent Electricity System Operator	Yes	
Luminant Generation Company, LLC	Yes	
City of Tallahassee	Yes	
Idaho Power	Yes	
Kansas City Power & Light	Yes	
Pepco Holdings Inc.	Yes	The 36 month time line is sufficient <b>Response:</b> The standard drafting team thanks you for your comment.
CPS Energy	Yes	

Organization	Yes or No	Question 7 Comment
Nebraska Public Power District (NPPD)	Yes	
Tacoma Power	Yes	
Ameren	Yes	
ITC	Yes	
Texas Reliability Entity	Yes	No comments.
Hydro One	Yes	
Hydro One	Yes	
Manitoba Hydro	Yes	
Lower Colorado River Authority	Yes	
American Transmission Company, LLC	Yes	
Georgia Transmission Corporation	Yes	
Tri-State Generation and Transmission Association, Inc.	Yes	

Organization	Yes or No	Question 7 Comment
Consumers Energy Company	Yes	
Bonneville Power Administration		<p>BPA cannot estimate if the implementation plan provides sufficient time until BPA determines how many elements that R1 applies to.</p> <p><b>Response:</b> The standard drafting team contends that a 36 calendar month implementation of Requirement R4 (now Requirement R2) provides ample time for entities to address the initial influx of identified Elements, if any. Entities should keep in mind that, for example, that Requirement R4 (now Requirement R2) allows a 12 calendar month period to evaluate load-responsive protective relays on the Element which means the entity will have nearly 48 months for completion depending on identification of the Element. No change made.</p>

8. If you have any other comments on PRC-026-1 that have not been stated above, please provide them here:

**Summary Consideration:** The following summarizes all other comments received starting with the comments that resulted in a change to the Standard and followed by a summary of comments that did not result in a change to the Standard. Comments summarized in Questions 1-7 are not summarized in this section. See the summaries to the first seven questions.

There were two minor themes of comments that resulted in a revision to the Standard. First, one comment supported by 14 individuals expressed concern about the use of “Elements” rather than “Facilities.” The standard drafting team modified the language in the Applicability section and Draft 3, Requirements R1 and R2 to more clearly note “generator, transformer, and transmission line BES Elements to resolve the concern between the two terms defined in the *Glossary of Terms Used in NERC Reliability Standards*. Also, one comment supported by 14 individuals revealed that Draft 2, Requirement R4 (now Draft 3, Requirement R2) was not clear as to what “meets” the PRC-026-1 – Attachment B criteria. The standard drafting team revised the text in PRC-026-1 – Attachment B, Criterion A to clarify that an impedance-based relay used for tripping is expected to not trip for a stable power swing, when the relay characteristic is completely contained within the unstable power swing region. Draft 3, Requirement R2 (previously Draft 2, Requirement R4) was revised to evaluate and “to determine whether” relays meet the criteria.

There was one significant and two minor themes of comments that did not result in a revision to the Standard. The significant theme included three comments represented by 47 individuals which suggested changes that are inconsistent with the NERC style for writing; therefore, the suggested changes were not implemented.

The first minor theme included one comment supported by 24 individuals that pointed out that PRC-026-1 leaves out the use of transfer limits to correct for stable power swings. The standard drafting team notes that transfer limits are an important tool in the operation of the BES and are a form of operating limits, but not applicable to the Standard. The PRC-026-1 standard is addressing the risk from a planning standpoint regarding System Operating Limits (SOL) and actual events where the Generator Owner and Transmission Owner becomes aware of a generator, transformer, or transmission line BES Element that tripped in response to a stable or unstable power swing due to the operation of its protective relay(s).

Second, one comment represented by 14 individuals commented that it is possible for protective relays applied on a substation bus section or on a FACTS<sup>26</sup> device to be susceptible to power swings, and in fact, in cases of intentional system separation schemes, this may be an intentional design (e.g., splitting a substation bus when one or a group of transmission lines exceed a measured condition). The standard drafting team investigated this concern with a few entities and determined there was not a concern that

---

<sup>26</sup> Flexible AC Transmission System

would lead to these Elements being added to the Standard’s Applicability. Also, these devices were not suggested as applicable Elements in the PSRPS Report,<sup>27</sup> which recommended an approach to a Reliability Standard.

Organization	Question 8 Comment
<p>Northeast Power Coordinating Council</p>	<p>The wording of the Purpose should not have been changed. The existing wording” do not trip” is definitive; the proposed wording “...are expected to...” leaves room for questioning. If the proposed wording is kept, suggest that the Purpose read:</p> <p>To ensure that load-responsive protective relays are not expected to trip in response to stable power swings during non-Fault conditions.</p> <p><b>Response:</b> The standard drafting team phrased the purpose statement to “expected to ‘not’ trip” because the expectation is that relays “not trip” in response to a power swing. No change made.</p> <p>Regarding requirements R1, R2 and R3, to be consistent with the format of other NERC standards, the Criteria/Criterion listings should be made Parts of requirements R1, R2 and R3.</p> <p><b>Response:</b> The standard drafting team contends that Requirement R1 is written in a clear manner to provide the criterion for which the Planning Coordinator must identify certain Elements to be notified to the respective Generator Owner and Transmission Owner. No change made.</p> <p>The standard drafting team removed Requirements R2 and R3. Change made.</p> <p>Requirement R1 has the Planning Coordinator notifying the respective Generator Owner and Transmission Owner but a specific time period to complete the notification following the identification of an Element is not specified. This may appear as a gap in the process. The Planning Coordinator should have 30 days to notify the TO and GO.</p> <p><b>Response:</b> The standard drafting team contends that it is sufficient for the Planning Coordinator to notify the respective Generator Owner and Transmission Owner on a calendar-year basis. Notification</p>


<sup>27</sup> NERC System Protection and Control Subcommittee, *Protection System Response to Power Swings*, August 2013: [http://www.nerc.com/comm/PC/System%20Protection%20and%20Control%20Subcommittee%20SPCS%2020/SPCS%20Power%20Swing%20Report\\_Final\\_20131015.pdf](http://www.nerc.com/comm/PC/System%20Protection%20and%20Control%20Subcommittee%20SPCS%2020/SPCS%20Power%20Swing%20Report_Final_20131015.pdf)

Organization	Question 8 Comment
	<p>is at the discretion of the PC based on when it identifies Elements, if any, according to the most recent annual Planning Assessment. Based on the time horizons of the Requirements and the objectives of the standard, adding a specified time frame to complete the notification adds no reliability benefit. No change made.</p> <p>PRC-026 leaves out the use of transfer limits to correct for stable power swings. Transfer limits are an important tool for use in power system operations, and should be mentioned in a Rationale Box.</p> <p><b>Response:</b> The standard drafting team notes that transfer limits are an important tool in the operation of the Bulk Electric System and are a form of operating limits. The PRC-026-1 standard is addressing the risk from a planning standpoint regarding System Operating Limits (SOL) and actual events where the Generator Owner and Transmission Owner become aware of a stable or unstable power swing that trips an Element.</p> <p>Entities should not be exempted from the standard because of the linkage to Attachment A. Attachment A should not exclude Relay elements supervised by power swing blocking. Entities may install out of step blocking in order to be exempted from the standard. An entity may install Out of Step Blocking equipment without validating that it is set correctly because PRC-026 would not apply.</p> <p><b>Response:</b> The standard drafting team contends that the installation of power swing blocking relays is an effective means to prevent tripping for stable power swings. The drafting team contends that entities that implement power swing blocking (PSB) relays would do so using engineering judgment and accepted industry practices. A discussion of PSB is in the Application Guidelines. No change made.</p> <p>Measure M3 is missing the word “meet”. Measure M3 should read: M3. Each Generator Owner shall have dated evidence that demonstrates identification of the Element(s), if any, which meet the criterion in Requirement R3. Evidence may include, but is not limited to, the following documentation: emails, facsimiles, records, reports, transmittals, lists, or spreadsheets.</p> <p><b>Response:</b> This Measure was deleted; therefore, eliminated the error. Change made.</p>
Arizona Public Service Co	The 30 days notification requirements for R2 and R3 is unnecessarily too stringent. We suggest 90 days.

Organization	Question 8 Comment
	<p><b>Response:</b> The standard drafting team removed Requirements R2 and R3; therefore, the issue is no longer present. Change made.</p>
<p>Southern Company; Southern Company Services, Inc.; Alabama Power Company; Georgia Power Company; Gulf Power Company; Mississippi Power Company; Southern Company Generation; Southern Company Generation and Energy Marketing</p>	<p>The NERC SPCS report, Protection System Response to Power Swings (dated August 2013), recommended that NERC reliability standard to address relay performance during stable swings is not needed, and could result in unintended adverse impacts to Bulk-Power System reliability. This report also noted that relay tripping on stable power swings were not casual or contributory in any of the historical events reviewed. According to report it appears that SPCS team did get an input from SAMS team and other industry experts before arriving to the conclusion. So, there is no need of this standard.</p> <p><b>Response:</b> The standard drafting team thanks you for your comment and provided a detailed explanation in the previous Consideration of Comments<sup>28</sup> in the introductory remarks regarding the need for a standard to meet regulatory directives.</p> <p>The calculation criteria in Attachment B, reduces the probability of relay tripping for stable swings but is not completely fool proof. The swing characteristics vary a lot based on system conditions, such as, system load, topology, generation status and amount of generation etc. So, it is proposed that the relay settings are reviewed and modified as needed by PC or TP based on transient stability analysis instead of setting them based on criteria in attachment B.</p> <p><b>Response:</b> The Attachment B criteria provides a consistent and conservative method for determining a relay’s susceptibility to tripping for stable power swings. Requiring Planning Coordinators or Transmission Planners to run additional stability studies to determine a relay’s susceptibility to tripping for a stable power swing will be more time consuming than applying the Criteria in Attachment B. Further, the contingencies assessed may not be severe enough to adequately ascertain a relay’s susceptibility to tripping for a stable power swing.</p> <p>The option to use an angle less than 120 degrees where a documented transient stability analysis demonstrates the expected maximum stable separation angle is less than 120 degrees is intended to</p>

<sup>28</sup> [http://www.nerc.com/pa/Stand/Project%202010133%20Phase%203%20of%20Relay%20Loadability%20stabl/Project\\_2010\\_13.3\\_Consideration\\_of\\_Comments\\_2014\\_08\\_22\\_to\\_Draft\\_1.pdf](http://www.nerc.com/pa/Stand/Project%202010133%20Phase%203%20of%20Relay%20Loadability%20stabl/Project_2010_13.3_Consideration_of_Comments_2014_08_22_to_Draft_1.pdf)



Organization	Question 8 Comment
	<p>allow entities to reduce the separation angle where it is supported by a transient stability analysis. No change made.</p> <p>Editorial comments:</p> <p>Comments for PRC-026-1</p> <ol style="list-style-type: none"> <li>Page 5 – Background Section<sup>29</sup> <p>This Phase 3 of the project establishes requirements aimed at preventing protective relays from tripping unnecessarily due to stable power swings by requiring the identification of Elements on which a power swing may affect Protection System operation, and to develop requirements to assess the security of load-responsive protective relays to tripping in response to a stable power swing. Last, to require entities to implement Corrective Action Plans, where necessary, to improve security of <b>security of</b> load-responsive protective relays for stable power swings so they are expected to not trip in response to stable power swings during non-Fault conditions while maintaining dependable fault detection and dependable out-of-step tripping.</p>  <p><b>Response:</b> Correction made.</p> <p>Comments for Application Guidelines</p> <ol style="list-style-type: none"> <li>Page 1 - “The development of this standard implements the majority of the approaches suggested by the report.” <p><b>Response:</b> Correction made, added “es” to approach.</p> </li> <li>Page 6 - “The standard does not included any requirement for the entities to provide information that is already being shared or exchanged between entities for operating needs.” <p><b>Response:</b> The standard drafting team chose not to include communication requirements between the Generator Owner and Transmission Owner for the exchange of source impedance data at a given transmission interconnection point, because the standard drafting team is confident this exchange of</p> </li> </ol> </li> </ol>

<sup>29</sup> The graphic and the text above the graph were appended to the stakeholder’s comment original comment due to a technical problem with the electronic submittal.

Organization	Question 8 Comment
	<p>source impedance data is already occurring outside of Reliability Standard requirements. A communication Requirement for the exchange of source impedance data would be administrative in nature, and would create additional compliance tracking burdens for both entities. No change made.</p> <p>3. Page 8 - “In order to establish a time delay that strikes a line between a high-risk...” What is meant by “strikes”?</p> <p><b>Response:</b> The SDT revised the language in this sentence removing the word “strikes”. It now reads “In order to establish a time delay that distinguishes a high-risk load-responsive protective relay from one that has a time delay for tripping (lower-risk), a sample of swing rates were calculated based on a stable power swing entering and leaving the impedance characteristic as shown in Table 1.” Change made.</p> <p>4. Page 8 - “For a relay impedance characteristic that has the swing entering and leaving beginning at 90 degrees with a termination at 120 degrees before exiting the zone...” “Add degrees”</p> <p><b>Response:</b> Addition made.</p> <p>5. Page 9 - Title of “Application to Transmission Elements”, should be “Application Specific to Criteria A”.</p> <p><b>Response:</b> Thank you for suggestion; however, the standard drafting team prefers to leave the heading as is.</p> <p>6. Page 9 - reference Fig 13 and 14 when discussing “infeed effect”</p> <p><b>Response:</b> Added reference to Figures 13 and 14 at the end of the “infeed-effect” text under “Application to Transmission Elements.”</p> <p>7. Figure 3 - Update text box “Constant Angle...Boundary (120 degrees)”.</p> <p><b>Response:</b> The standard drafting team was unable to determine the change needed.</p> <p>8. Table 2 through 7 - Do not need to calculate each point, does not provide added value to the document.</p> <p><b>Response:</b> Thank you for comment. The standard drafting team considered other approaches to reduce the redundancy of the calculations. For example, having the six points in a six column table, but the</p>

Organization	Question 8 Comment
	<p>font became too small for readability. Six points are considered the critical points to which an entity would need to calculate the lens characteristic.</p> <p>9. There are many tables and figures not referenced in the written portion of the document which makes the guideline difficult to read and follow. This is the case for Figure 13, 14, 15, and almost all the tables.</p> <p><b>Response:</b> Several of the Tables and Figures are standalone by design and where a figure is used in discussion, it is referenced.</p>
<p>ISO RTO Council Standards Review Committee</p>	<p>The SRC respectfully submits that the Purpose statement is unclear and inconsistent with the requirements in the standard. More specifically, the requirements often refer to stable and unstable power swings, but such are not addressed in the Purpose statement. This should be clarified. The following revision is proposed. To protect against tripping by load-responsive protective relays in response to stable and unstable power swings during non-Fault conditions.</p> <p><b>Response:</b> The standard drafting team believes the Purpose Statement appropriately captures the intent of the standard according to the directives the standard is responding to in the FERC Order No. 733.</p> <p>It is important to note that this standard does not require that entities assess Protection System performance during unstable swings and does not require entities to prevent tripping in response to unstable swings. Such requirements would exceed the directive stated in the Federal Energy Regulatory Commission (FERC) Order No. 733. This standard focuses on the identification of Elements by the Planning Coordinator (Requirement R1) and Elements where the Generator Owner or Transmission Owner becomes aware of an Element that tripped in response to a stable or unstable power swing (Draft 3, Requirement R2, 2<sup>nd</sup> bullet). Requirement R1 and R2 (2<sup>nd</sup> bullet) is a screen to identify Elements that are subject to the Requirements of the standard.</p> <p>The FERC Order No. 733 directive is perceived as broad and overreaching and could require all relays to be capable of differentiating between stable power swings and faults. This standard's focused</p>

Organization	Question 8 Comment
	<p>approach is based on the PSRPS Report,<sup>30</sup> recommending “...lines that have tripped due to power swings during system disturbances...” as one of the ways to focus the evaluation. Based on feedback from the contributors to the PSRPS Report, that recommendation does not exclude unstable power swings. Furthermore, it is reasonable to assume that an Element that experiences an unstable swing (in either a simulation or reality) is likely to experience large stable power swings for less severe disturbances (that are probably more likely to occur). Thus, the standard drafting team concluded that addressing Protection Systems for Elements that tripped due to unstable power swings provides a reliability benefit. No change made.</p> <p>The SRC has concerns with potential inconsistency between the Purpose statement and the time horizons. Specifically, Requirements R2 and R3 have a time horizon defined as Long Term Planning while the Purpose of the standard is about expected / forecasted responses. However, the verbiage of Requirements R2 and R3 requires action by the responsible entities within 30 days, which implies that the Time Horizon should be, at most, the Operations Planning time frame. The SRC requests that the SDT to review these requirements to assure they are consistent with the purpose of the standard, the Time Horizons and any changes necessary to the Applicability section.</p> <p><b>Response:</b> The standard drafting team removed Requirements R2 and R3; therefore, the issue is no longer present. Change made.</p>
Dominion	<p>No part of the standard discusses reasonable slip frequencies that should be used to detect power swings. If we identify a relay that is susceptible to tripping for stable power swings (based on the mho impedance characteristic overlapping a portion of the lens), apply a form of power swing blocking, and then the relay operates again for a different frequency. Are we to go off the most recent analysis?</p> <p>Slip frequency is an integral part to power swing detection and determination between a swing and loading can be difficult. There should be some discussion about this topic in conjunction with loading. Should a section discuss the correlation with PRC-023-2 requirement R2?</p>

<sup>30</sup> NERC System Protection and Control Subcommittee, *Protection System Response to Power Swings*, August 2013: [http://www.nerc.com/comm/PC/System%20Protection%20and%20Control%20Subcommittee%20SPCS%2020/SPCS%20Power%20Swing%20Report\\_Final\\_20131015.pdf](http://www.nerc.com/comm/PC/System%20Protection%20and%20Control%20Subcommittee%20SPCS%2020/SPCS%20Power%20Swing%20Report_Final_20131015.pdf)

Organization	Question 8 Comment
	<p>PRC-023-2 R2. Each Transmission Owner, Generator Owner, and Distribution Provider shall set its out-of-step blocking elements to allow tripping of phase protective relays for faults that occur during the loading conditions used to verify transmission line relay loadability per Requirement R1.</p> <p><b>Response:</b> The standard drafting team notes that the use of slip frequencies in the setting of power swing blocking relay(s) is outside the scope of the standard. No change made.</p>
DTE Electric Co.	<p>Will this Standard result in any conflicts with PRC-019 or PRC-025 while meeting protection goals in setting generator relays?</p> <p><b>Response:</b> The standard drafting team is unaware of any conflicts.</p>
ACES Standards Collaborators	<p>(1) We believe the data retention section is inconsistent with the RAI. RAI is intended to refocus the ERO’s compliance monitoring and enforcement efforts on those matters that pose the greatest risk to the reliability to the BES. This involves making compliance monitoring and enforcement forward looking to provide reasonable assurance of future compliance and reliability. How does a three-year data retention requirement support this forward looking vision of RAI? We suggest that the data retention should be no more than one year, based on the annual cycle established in this standard.</p> <p><b>Response:</b> The standard drafting team has revised the minimum periods to retain evidence to 12 calendar months in the Evidence Retention section to address Risk Assurance Initiative (RAI) concerns. Change made.</p> <p>(2) Why is 36 calendar months in bullet 4 instead of 3 calendar years that is used in the first three bullets? It seems they should be the same to avoid confusion. Notwithstanding our earlier comments regarding making the data retention period no longer than one year, we suggest using consistent language throughout the data retention section. Thus, use either 36 calendar months or three calendar years, but not both.</p> <p><b>Response:</b> The standard drafting team has revised the minimum periods to retain evidence to 12 calendar months in the Evidence Retention section to address Risk Assurance Initiative (RAI) concerns. Change made.</p>

Organization	Question 8 Comment
<p>Bonneville Power Administration</p>	<p>BPA suggests re-ordering the requirements for continuity because the standard is working/designing the system to prevent trips by load-responsive relays unnecessarily.</p> <p>R1 (PC identify criteria influenced Elements ANNUALLY)</p> <p>R4 (GO/TO evaluate elements identified by the PC’s identifier of Gen restraint, line part of SOL angular, UFLS line boundary )R5 (GO/TO develop a CAP for at risk protection on R4 elements)</p> <p>R6 (GO/TO implement the CAP)</p> <p>R2 (TO notify PC within 30 days if an element trips by load-responsive protection due to swings or forms a boundary during a actual system Disturbance)</p> <p>R3 (GO notifies PC within 30 days if element trips by load-responsive protection during a swing)</p> <p><b>Response:</b> The standard drafting team thanks you for your comment and notes that Requirements R2 and R3 have been removed and changes were made to the previous R4 (now Requirement R2) to address other comments and concerns. Change made.</p>
<p>Entergy Services, Inc.</p>	<p>Based on the information contained in the SPCS Power Swing Report Dated August 2013, there is insufficient evidence in the historical study case identified, to warrant implementation of the proposed PRC-026-1 standard.</p> <p><b>Response:</b> The standard drafting team thanks you for your comment and provided a detailed explanation in the previous Consideration of Comments<sup>31</sup> in the introductory remarks regarding the need for a standard to meet regulatory directives.</p>
<p>Lincoln Electric System</p>	<p>Although aware of the forces driving the development of PRC-026-1, LES cannot support the standard. LES agrees with the statement in the NERC System Protection and Control Subcommittee’s technical report titled “Protection System Response to Power Swings” that recommends against this standard. Reliability Standards PRC-023-3 and PRC-025-1 adequately ensure that load-responsive protective</p>

<sup>31</sup> [http://www.nerc.com/pa/Stand/Project%202010133%20Phase%203%20of%20Relay%20Loadability%20stabl/Project\\_2010\\_13.3\\_Consideration\\_of\\_Comments\\_2014\\_08\\_22\\_to\\_Draft\\_1.pdf](http://www.nerc.com/pa/Stand/Project%202010133%20Phase%203%20of%20Relay%20Loadability%20stabl/Project_2010_13.3_Consideration_of_Comments_2014_08_22_to_Draft_1.pdf)

Organization	Question 8 Comment
	<p>relays will not trip in response to stable power swings during non-Fault conditions. Additionally, as stated in this same report, consideration should be given to potential adverse impacts to Bulk Power System reliability as a result of the standard.</p> <p><b>Response:</b> The standard drafting team thanks you for your comment and provided a detailed explanation in the previous Consideration of Comments<sup>32</sup> in the introductory remarks regarding the need for a standard to meet regulatory directives.</p>
<p>Xcel Energy</p>	<p>We believe there is insufficient technical basis to make this a viable standard for industry to properly apply, and provide the following comments for consideration:</p> <p>We concur with the NERC concern noted in #133 of FERC order 733 that careful study and analysis of the relationship between stable power swings and protective relays is needed and consultation with IEEE and other organizations should be completed before developing a Reliability Standard addressing stable power swings. The need basis for this standard is 2003 blackout event data. Since that time, many improvements to protection systems have occurred, voltage control and frequency control requirements have either been implemented, are on a staged implementation plan, or are planned in the immediate future. The need basis data set has changed and should be based on current information, rather than past uncontrolled system reliability program data. Many improvements over the last 11 years have changed the probability of this particular need occurring, including:</p> <ul style="list-style-type: none"> <li>o Use of Generator AVR and PSS systems</li> <li>o Improved facility equipment ratings</li> <li>o Automatic voltage and frequency ride-through standards for wind turbines</li> <li>o Coordinated protection system settings amongst all players</li> <li>o Better system modeling and transmission planning</li> </ul> <p>These concerns would be addressed by a carefully planned study as described.</p>

<sup>32</sup> [http://www.nerc.com/pa/Stand/Project%202010133%20Phase%203%20of%20Relay%20Loadability%20stabl/Project\\_2010\\_13.3\\_Consideration\\_of\\_Comments\\_2014\\_08\\_22\\_to\\_Draft\\_1.pdf](http://www.nerc.com/pa/Stand/Project%202010133%20Phase%203%20of%20Relay%20Loadability%20stabl/Project_2010_13.3_Consideration_of_Comments_2014_08_22_to_Draft_1.pdf)

Organization	Question 8 Comment
	<p>We are aware of FERC’s concerns around undesirable operations due to stable power swings, per Orders 733, 733A and 733B. The directive in #150 states “...we direct the ERO to develop a Reliability Standard that requires the use of protective relay systems that can differentiate between faults and stable power swings and, when necessary, phases out protective relay systems that cannot meet this requirement.” We are also aware that this requirement was reinforced on September 4th, in the applicable FERC staff meeting. Due to the real or perceived urgency in completing this standard, we have offered some proposed wording intended to expedite the acceptance of the regulation.</p> <p>As written, we believe this draft holds potential opportunities for improvements towards readability and cohesiveness.</p> <p><b>Response:</b> The standard drafting team thanks you for your comment and provided a detailed explanation in the previous Consideration of Comments<sup>33</sup> in the introductory remarks regarding the need for a standard to meet regulatory directives.</p>
Idaho Power	<p>The 30 day time requirement for notification of swing tripping events in R2 and R3 seems a little short. I think 45 to 60 days would be more appropriate.</p> <p><b>Response:</b> The standard drafting team thanks you for your comment and notes that Requirements R2 and R3 have been removed and changes were made to the previous R4 (now Requirement R2) to address other comments and concerns. Change made.</p>
ISO New England	<p>PRC-026 leaves out the use of transfer limits to correct for stable power swings. Transfer limits are an important tool for use in power system operations.</p> <p><b>Response:</b> The standard drafting team notes that transfer limits are an important tool in the operation of the Bulk Electric System and are a form of operating limits. The PRC-026-1 standard is addressing the risk from a planning standpoint regarding System Operating Limits (SOL) and actual events where the Generator Owner and Transmission Owner become aware of a stable or unstable power swing that trips an Element.</p>

<sup>33</sup> [http://www.nerc.com/pa/Stand/Project%202010133%20Phase%203%20of%20Relay%20Loadability%20stabl/Project\\_2010\\_13.3\\_Consideration\\_of\\_Comments\\_2014\\_08\\_22\\_to\\_Draft\\_1.pdf](http://www.nerc.com/pa/Stand/Project%202010133%20Phase%203%20of%20Relay%20Loadability%20stabl/Project_2010_13.3_Consideration_of_Comments_2014_08_22_to_Draft_1.pdf)



Organization	Question 8 Comment
	<p>Furthermore, Attachment A should not exclude Relay elements supervised by power swing blocking. Entities might simply install out of step blocking in order to be effectively exempted from the standard. An entity could just install Out of Step Blocking equipment with nothing to ensure that it is set correctly and the standard would not apply through the exclusion in Attachment A. This will not improve power system reliability.</p> <p><b>Response:</b> The standard drafting team contends that the installation of power swing blocking relays is an effective means to prevent tripping for stable power swings. The drafting team contends that entities that implement power swing blocking (PSB) relays would do so using engineering judgment and accepted industry practices. A discussion of PSB is in the Application Guidelines. No change made.</p>
<p>Nebraska Public Power District (NPPD)</p>	<p>We are curious why the PC is allowed 1 year to identify elements while the industry is allowed 30 days after a disturbance to identify elements. This does not seem practical in comparison with the timelines used with other reporting requirements. For example, PRC-004 has quarterly submissions with 2 additional months after the quarter end; the new PRC-004-3 allows 120 days just to identify if an operation was a misoperation, root cause determination is not included in that timeframe. In fact, PRC-004-3 includes no set timeline to determine cause, simply a requirement to actively investigate by indicating active investigation every two calendar quarters until a cause is determined or no cause can be found. An out-of-step analysis is more complex, so it would be logical to allow longer time horizons for this type of investigation and identification, perhaps no less than an annual interval which would match the PC.</p> <p><b>Response:</b> The standard drafting team contends that PRC-026-1 does not require an entity to determine whether an Element tripped due to a power swing. This is accomplished in the revision to Requirement R2 (previously Requirement R4) that when an entity “becomes aware” it would evaluate the relay(s). The identification of a power swing that causes a BES Element trip could be determined through an entity’s Protection System analysis process (e.g., PRC-004<sup>34</sup>), event analysis review by the entity, region, or NERC.</p> <p>Additional clarification on two items is requested:</p>

<sup>34</sup> Protection System Misoperation Identification and Correction.

Organization	Question 8 Comment
	<p>1) If a relay has out of step tripping and blocking enabled, does this mean it is excluded from the standard?</p> <p><b>Response:</b> The standard drafting team notes that out-of-step trip relaying must still comply with the criteria in Attachment B of the standard.</p> <p>2) If a relay has out of step blocking enabled, does this mean it is excluded from the standard?</p> <p><b>Response:</b> The standard drafting team notes that relay elements that are supervised by power swing blocking are excluded from the Requirements of this standard based on Attachment A.</p> <p>In addition to these comments, we support the comments provided by SPP.</p> <p><b>Response:</b> The standard drafting team thanks you for your comments, please see response to SPP Standards Review Group.</p>
Tacoma Power	<p>For Requirement R2, consider defining ‘island’ or adding a footnote clarifying the intent of the word. This requirement should not apply to portions of the system containing both generation and load that become isolated from the BES but that are not intended to operate apart from the BES. For example, perhaps there are parallel lines that interconnect one or more remote generation plants and some load to the rest of the system. It is doubtful that the drafting team intended to include these types of scenarios as ‘islands’.</p> <p><b>Response:</b> The standard drafting team removed Requirements R2 and R3; therefore, the issue is no longer present. Change made.</p> <p>Should POTT and DCB schemes be specifically called out in Attachment A as being applicable to PRC-026-1?</p> <p><b>Response:</b> The figures have been updated to generically refer to Pilot Zone 2 and Zone 2 impedance characteristics as “mho element characteristics.” A clarifying paragraph has also been added to the Guidelines and Technical Basis under the Requirement R2 heading which discusses the types of “pilot” or communications relay schemes that need to be considered. Change made.</p>

Organization	Question 8 Comment
	<p>Attachment B Criterion B may yield current that is above the phase time overcurrent pickup but, at this level of current, the phase time overcurrent element may take longer than 15 cycles to operate. Therefore, the approach in Attachment B Criterion B is potentially conservative.</p> <p><b>Response:</b> The standard drafting team thanks you for your comment.</p> <p>The Response to Issues and Directives still mentions that “...the proposed standard does require that an Element that was part of a boundary that formed an island since January 1, 2003 be identified as an that is within the scope of the proposed standard.”</p>
Ameren	<p>We appreciate the SDT’s significant improvements in this draft 2. Our response to question 3 above captures our primary reason for voting negative.</p> <p><b>Response:</b> Correction made.</p>
ITC	<p>In R2, add reference to Attachment A when describing the load-responsive protective relays. R2 Criteria 2 adds no value and should be removed. All Elements which trip due to swings will be captured under Criteria 1. Criteria 2 only includes islands formed due to phase faults and adds no value. If you intend to capture boundaries of all islands formed, then remove the “due to the operation of its load-responsive protective relays” qualifier. If you intend to capture boundaries of all islands formed due to protective relay operations, then remove the “load-responsive” qualifier.</p> <p><b>Response:</b> The standard drafting team removed Requirements R2 and R3; therefore, the issue is no longer present. Change made.</p> <p>Application Guidelines, page 63, Application to Generation Elements, change the language to include generator relays, if they are set based on equipment permissible overload capability. “Load-responsive protective relays such as time over-current, voltage controlled time-overcurrent or voltage-restrained time-overcurrent relays are excluded from this standard [if] they are set based on equipment permissible overload capability.”</p> <p><b>Response:</b> Correction made.</p>

Organization	Question 8 Comment
	<p>Application Guidelines, page 72, the first paragraph under Requirement R5 is more appropriate under Requirement R6.</p> <p><b>Response:</b> The standard drafting team eliminated the text.</p>
Texas Reliability Entity	<p>Texas RE suggests that the PRC-026-1 SDT refer this standard to the Project 2014-01 SDT (if not done already) for consideration regarding the applicability of BES generators to include dispersed generation resources so the requirements of the standard pertain primarily to the point of connection where the resources aggregate to 75 MVA or more, and not to the individual resources. Since this is a new standard it is not currently included in “Appendix B: List of Standards Recommended for Further Review” from the draft white paper entitled “Proposed Revisions to the Applicability of NERC Reliability Standards NERC Standards Applicability to Dispersed Generation Resources.”</p> <p><b>Response:</b> The standard drafting team has been coordinating with the dispersed generation resources project team. No conflicts have been identifies.</p>
CenterPoint Energy	<p>CenterPoint Energy recommends removing references to “unstable” power swings in the draft PRC-026-1 standard, as we believe tripping from unstable power swings is random and not indicative of an Element being more susceptible to a stable power swing. Where tripping actually occurs for an unstable power swing is dependent on the location and nature of the event, system conditions, and where additional Element outages occur during a disturbance. We are not aware of any available technical information or analysis to justify that an Element is more susceptible to a stable power swing if it has tripped from an unstable power swing.</p> <p><b>Response:</b> It is important to note that this standard does not require that entities assess Protection System performance during unstable swings and does not require entities to prevent tripping in response to unstable swings. Such requirements would exceed the directive stated in the Federal Energy Regulatory Commission (FERC) Order No. 733. This standard focuses on the identification of Elements by the Planning Coordinator (Requirement R1) and Elements where the Generator Owner or Transmission Owner becomes aware of an Element that tripped in response to a stable or unstable power swing (Draft 3, Requirement R2, 2<sup>nd</sup> bullet). Requirement R1 and R2 (2<sup>nd</sup> bullet) is a screen to identify Elements that are subject to the Requirements of the standard.</p>

Organization	Question 8 Comment
	<p>The FERC Order No. 733 directive is perceived as broad and overreaching and could require all relays to be capable of differentiating between stable power swings and faults. This standard’s focused approach is based on the PSRPS Report,<sup>35</sup> recommending “...lines that have tripped due to power swings during system disturbances...” as one of the ways to focus the evaluation. Based on feedback from the contributors to the PSRPS Report, that recommendation does not exclude unstable power swings. Furthermore, it is reasonable to assume that an Element that experiences an unstable swing (in either a simulation or reality) is likely to experience large stable power swings for less severe disturbances (that are probably more likely to occur). Thus, the standard drafting team concluded that addressing Protection Systems for Elements that tripped due to unstable power swings provides a reliability benefit. No change made.</p>
<p>Duke Energy</p>	<p>Duke Energy agrees in part with the revisions made by the SDT on this project. However, due to the amount of technical information provided in the Application and Guidelines portion of this standard, more time is needed for our SME(s) to thoroughly review this section before submitting an “Affirmative” vote.</p> <p><b>Response:</b> The standard drafting team thanks you for your comment.</p>
<p>Florida Municipal Power Agency</p>	<p>FMPA would like to commend the SDT for developing an overall process that is generally reasonable and does not, in our opinion, add an excessive compliance burden, since the number of identified circuits and generators should be small. However, we believe more work is required to make the concept the SDT has come up with successful.</p> <p>1. First, as mentioned in earlier sections, the standard is in general written with the perspective of large vertically integrated utilities in mind, and does not consider the impact on non-vertically integrated TOs and GOs. As such, we believe there is further coordination that needs to be developed between this standard and PRC-004, that will</p>

<sup>35</sup> NERC System Protection and Control Subcommittee, *Protection System Response to Power Swings*, August 2013: [http://www.nerc.com/comm/PC/System%20Protection%20and%20Control%20Subcommittee%20SPCS%2020/SPCS%20Power%20Swing%20Report\\_Final\\_20131015.pdf](http://www.nerc.com/comm/PC/System%20Protection%20and%20Control%20Subcommittee%20SPCS%2020/SPCS%20Power%20Swing%20Report_Final_20131015.pdf)

Organization	Question 8 Comment
	<p>a) facilitate communication between PCs, TPs, TOPs, the RC, and respective investigating TOs and GOs and</p> <p>b) will establish a clear timeline that can cleanly be audited for R2 and R3. As stated in our comments above on R2, the requirements for keeping records for “correct” relay operations are effectively non-existent in current standards.</p> <p>FMPA believes it makes sense for all “investigations” and associated records to occur within PRC-004 and then for “power swing” related activities to occur in PRC-026. Currently power swings are only discussed in PRC-004 as they relate to failure to trip or slow trip conditions (and not where operation for a power swing was correct). Furthermore there is presently no acknowledgment that GOs and TOs may need assistance and information from their TPs, PCs, associated TOP, or even RC.</p> <p><b>Response:</b> The standard drafting team contends that PRC-026-1 does not require an entity to determine whether an Element tripped due to a power swing. This is accomplished in the revision to Requirement R2 (previously Requirement R4) that when an entity “becomes aware” it would evaluate the relay(s). The identification of a power swing that causes a BES Element trip could be determined through an entity’s Protection System analysis process (e.g., PRC-004<sup>36</sup>), event analysis review by the entity, region, or NERC.</p> <p>There is no requirement to track “correct” operations now that Requirement R2 (previously Requirement R4) is triggered on becoming aware of a trip that is due to a power swing. The entity would maintain records demonstrating compliance with the Requirement upon becoming aware of the trip.</p> <p>The standard drafting team chose not to include communication requirements between the Generator Owner and Transmission Owner for the exchange of source impedance data at a given transmission interconnection point, because the standard drafting team is confident this exchange of source impedance data is already occurring outside of Reliability Standard requirements. A communication Requirement for the exchange of source impedance data would be administrative in nature, and would create additional compliance tracking burdens for both entities. No change made.</p>

<sup>36</sup> Protection System Misoperation Identification and Correction.

Organization	Question 8 Comment
	<p>2. The Applicability section refers to GO’s and TO’s that apply load responsive relays to Generators, Transformers, and Transmission Lines. FMPA sees three issues related to this.</p> <p>a. First, all language in the standard Requirements refers to Elements instead of Facilities - based on previous comments and the SDT’s response to those comments, the standard Requirements should be referring to Facilities to draw focus to the BES distinction, which does not exist for Elements.</p> <p><b>Response:</b> The standard drafting team has modified the language in the Applicability section and Requirements R1 and R2 (previously Requirement R4) to more clearly note “BES generator, transformer, and transmission line Elements. Change made.</p> <p>b. Second, the identification of issues and tracking of issues from entity to entity is based on Elements. This works from the perspective of identification of risks to the system but falls short when it comes time to evaluate and modify the Protection Systems, because no Requirement refers back to the Owner of the Protection Systems applied on the Elements identified in R1. Instead, Requirements 2 and 3 are directed at the Owner of the Element itself which may or may not own the Protection System that is actually at risk of operating (or misoperating). The Requirements need to consider this relationship similar to PRC-004-3.</p> <p><b>Response:</b> The standard drafting team removed Requirements R2 and R3; therefore, the issue is no longer present. Change made.</p> <p>c. Third, it is quite possible for protective relays applied on a substation bus section or on FACTS devices to be susceptible to power swings, and in fact, in cases of intentional system separation schemes, this may be an intentional design (e.g splitting a substation bus when one or a group of transmission lines exceed a measured condition). The Facilities section does not include such Elements.</p> <p><b>Response:</b> The standard drafting team notes that these devices are not suggested as applicable Elements in the PSRPS Report<sup>37</sup> which recommended an approach to a Reliability Standard. No change made.</p>

<sup>37</sup> NERC System Protection and Control Subcommittee, *Protection System Response to Power Swings*, August 2013: [http://www.nerc.com/comm/PC/System%20Protection%20and%20Control%20Subcommittee%20SPCS%2020/SPCS%20Power%20Swing%20Report\\_Final\\_20131015.pdf](http://www.nerc.com/comm/PC/System%20Protection%20and%20Control%20Subcommittee%20SPCS%2020/SPCS%20Power%20Swing%20Report_Final_20131015.pdf)

Organization	Question 8 Comment
	<p>3. FMPA is concerned the conditions under which Criteria A is being calculated may be excessively conservative. Item 3 of the Criteria states “Saturated (transient or sub-transient) reactance is used for all machines.” Note the term “all”, which could be confusing if an entity is not considering the context. The documentation presented does not discuss terms such as “maximum generation dispatch” or any other term that would relate back to a realistic number of generators being in service. The requirement should be “all machines that are in service in short circuit model”, and in the Application Guide there should be some discussion on using maximum reasonable generation dispatches in short circuit cases. Similarly, but of less consequence, it is not clear that the Transfer Impedance should always be completely neglected. While this is certainly numerically convenient, FMPA wonders if this does not produce overly conservative results in cases of well-networked transmission. Would it not be more prudent to remove other transmission circuits which have significant transfer distribution factors relative to the line in question, and then re-calculate the transfer impedance, rather than assuming some exceedingly large number of transmission outages has occurred? This relates to the comment above that some discussion should be offered surrounding Table 10 in the Application Guide.</p> <p><b>Response:</b> The standard drafting team contends that the Attachment B criteria provides a consistent and conservative approach to achieving the intent of the standard. The Guidelines and Technical Basis have additional text regarding the transfer impedance and Table 10.</p> <p>4. As written, the combination of Requirement R4 (which instructs the TO/GO to “evaluate” its relays against the “Criteria” in Attachment B) and the Criteria in Attachment B, make no definitive statements about what relays “meet” anything, or “are deficient and require corrective action plans” etc. Requirements and Criteria should be very clear and straight forward. The “Criteria” is really just a description. There is no information in the Requirement or in the Attachment that actually involves making a “judgment” which is the most important part of the definition of the term Criteria. FMPA is well aware of the intent of these two items and only wishes to point out that the intent is really only made clear in the Application Guidelines.</p> <p><b>Response:</b> The standard drafting team has revised the text in Attachment B, Criterion A to clarify that an impedance-based relay used for tripping is expected to not trip for a stable power swing, when the relay characteristic is completely contained within the unstable power swing region. Requirement R2</p>



Organization	Question 8 Comment
	(previously Requirement R4) was revised to evaluate and “to determine whether” relays meet the criteria. Change made.
SPP Standards Review Group	<p>Delete the reference to PRC-026-1 in 4.1.1 and 4.1.3 in the Applicability section. Leave the references simply as Attachment A.</p> <p><b>Response:</b> The standard drafting team prefers to leave the reference in because it maintains consistency with the other two relay loadability standards (i.e., PRC-023 and PRC-025) and provides an appropriate reference to the attachment is separated from the standard itself. No change made.</p> <p>Delete ‘This’ in the 1st line of the 4th paragraph under 5. Background:.</p> <p><b>Response:</b> The standard drafting team correction made.</p> <p>At the end of the 6th line and beginning of the 7th line in the same paragraph, delete ‘of security’.</p> <p><b>Response:</b> The standard drafting team correction made.</p> <p>Hyphenate 30-, 60-, 90-calendar days and similar construction with calendar months throughout the standard.</p> <p><b>Response:</b> The standard drafting team notes that the current formatting of days noted above is consistent with the NERC document style guide. No change made.</p> <p>At the end of each of the first three bullets in 1.2 Evidence Retention the phrase ‘following the completion of each Requirement’ appears. Since each bullet only refers to one requirement what does this phrase mean when applied to Requirements R1, R2 and R3 individually?</p> <p><b>Response:</b> The standard drafting team has replaced “each” with “the” for clarity. Change made.</p> <p>Why is the timing for notification in the VSLs for the Transmission Owner in Requirement R2 and the Generation Owner in Requirement R3 different from that for the Planning Coordinator in Requirement R1? Shouldn’t they be the same?</p> <p><b>Response:</b> The standard drafting team removed Requirements R2 and R3; therefore, the issue is no longer present. Change made.</p>

Organization	Question 8 Comment
	<p>We recommend that all changes made to the standard be reflected in the RSAW as well.</p> <p><b>Response:</b> The standard drafting team will provide input to NERC Compliance regarding the RSAW.</p>
City of Tallahassee	<p>This standard will cause a large increase in workload for entities with a small trade off of system reliability.</p> <p><b>Response:</b> The standard drafting team notes that the standard is presenting an equally effective and efficient approach to the Federal Energy Regulatory Commission (FERC) Order No. 733 directive, and is narrowly focused on specific Elements, and reduces the burden to entities when compared to the directive in Order No. 733. See the “Table of Issues and Directives” document in the posting for FERC’s original directive. NERC is obligated to respond to FERC’s directive.</p>
Exelon Companies	<p>We agree with the drafting teams’ decision that only those elements that trip in less than 15 cycles need to be evaluated for susceptibility to tripping during stable power swings. This follows from actual event experience that shows that the vast majority of relays that trip during power swings are zone 1s.</p> <p><b>Response:</b> The standard drafting team thanks you for your support.</p>

**END OF REPORT**

# Notice of Request to Waive the Standard Process

## Project 2010-13.3 – Phase 3 of Relay Loadability: Stable Power Swings

As required by Section 16 of the NERC [Standard Processes Manual](#) (SPM), this is official notice to stakeholders that the leadership of the Project 2010-13.3 Protection System Response to Power Swings Standards Drafting Team (PSRPS SDT), the Project Management and Oversight Subcommittee liaison, the Standards Committee (SC) chair, and NERC Standards staff (Requesters) are requesting that the SC consider a waiver of the SPM. The Requesters ask to shorten the next formal comment and ballot period for draft standard PRC-026-1 – Relay Performance During Stable Power Swings, and any subsequent formal comment and ballot periods for that standard, from forty-five days to twenty-one days, with a ballot and non-binding poll during the last seven days, and to shorten the final ballot for PRC-026-1 from ten days to seven days, in order to meet a Federal Energy Regulatory Commission (FERC) regulatory deadline. Section 16 of the SPM provides for the granting of a waiver for a regulatory deadline.

The SC will meet via teleconference to consider this waiver on its regularly scheduled Wednesday, October 22, 2014 call (to comply with the five business days' notice required by Section 16 of the SPM, this notice and its accompanying one-pager were submitted to the SC on October 15, 2014). The SC's teleconference will be noticed through an announcement and posted on the NERC website. Additional details about the waiver request are included below, and should a waiver be granted by the SC, it will be posted on the [project page](#).

### Justification for Current Waiver Request

In Order No. 733, FERC directed the development of a Reliability Standard to address the use of protective relay systems that can differentiate between faults and stable power swings.<sup>1</sup> The PSRSP SDT is proposing an equally efficient and effective Reliability Standard to address the directive. The proposed PRC-026-1 Reliability Standard is consistent with guidance provided in the NERC System Protection and Control Subcommittee report [Protection System Response to Power Swings, August 2013](#). PRC-026-1 has been posted for two 45-day formal comment periods and ballots, receiving approval ratings of 17.02% and 53.02%, respectively.

The shortened comment period and ballot for PRC-026-1 serves several important purposes. First, the shortened comment period will allow for one additional formal comment period and ballot, while still allowing the standard to be filed with FERC by the December 31, 2014 deadline. This will also enable the drafting team to conduct additional outreach prior to the start of the ballot which may be important to ensure stakeholder support. Shortening the final ballot period from ten days to seven

<sup>1</sup> *Transmission Relay Loadability Reliability Standard*, Order No. 733, P150, 130 FERC ¶ 61,221 (2010) ("Order No. 733").

days also provides scheduling flexibility that may be required to achieve the necessary milestones including scheduling a special call for NERC Board of Trustees adoption, while still allowing NERC and the industry to successfully meet the filing deadline.

### **Standards Development Process**

The [Standard Processes Manual](#) contains all the procedures governing the standards development process. The success of the NERC standards development process depends on stakeholder participation. We extend our thanks to all those who participate.

*For more information or assistance, please contact Scott Barfield-McGinnis, Standards Developer, at [scott.barfield@nerc.net](mailto:scott.barfield@nerc.net) or at 404-446-9689.*

North American Electric Reliability Corporation  
3353 Peachtree Rd, NE  
Suite 600, North Tower  
Atlanta, GA 30326  
404-446-2560 | [www.nerc.com](http://www.nerc.com)

## Waiver Authorization for Project 2010-13.3 Phase 3 of Relay Loadability: Stable Power Swings

### Action

Authorize a waiver of the Standard Process Manual (SPM) to:

- a) Shorten the next additional formal comment period (and any subsequent additional formal comment periods) for draft standard PRC-026-1 – Relay Performance During Stable Power Swings from forty-five days to twenty-one days, with a ballot and non-binding poll during the last seven days of the twenty-one day period; and
- b) Shorten the final ballot period from ten days to seven days.

### Background

The leadership of the Protection System Response to Power Swings Standard Drafting Team (PSRPS SDT), NERC Staff, and the Project Management and Oversight Subcommittee liaison and chair of the Standards Committee (SC) have requested a waiver of the NERC Standards Processes Manual (SPM) as described in the actions above. Section 16 of the SPM provides for the granting of waivers to meet a regulatory deadline. As required in Section 16, NERC provided stakeholders with five business days' notice of this waiver. If a waiver is authorized, NERC will post notice of the waiver and notify the NERC Board of Trustees Standards Oversight and Technology Committee.

In Order No. 733, The Federal Energy Regulatory Commission (FERC) directed the development of a Reliability Standard to address the use of protective relay systems that can differentiate between faults and stable power swings.<sup>1</sup> The PSRSP SDT is proposing an equally efficient and effective Reliability Standard to address the directive. The proposed PRC-026-1 Reliability Standard is consistent with guidance provided in the NERC System Protection and Control Subcommittee report [Protection System Response to Power Swings, August 2013](#). PRC-026-1 has been posted for two 45-day formal comment periods and ballots, receiving approval ratings of 17.02% and 53.02, respectively.

The shortened comment period and ballot for PRC-026-1 serves several important purposes. First, the shortened comment period will allow for one additional formal comment period and ballot, while still allowing the standard to be filed with FERC by the December 31, 2014 deadline. This will also enable the drafting team to conduct additional outreach prior to the start of the ballot which may be important to ensure stakeholder support. Shortening the final ballot period from ten days to seven days also provides scheduling flexibility that may be

---

<sup>1</sup> *Transmission Relay Loadability Reliability Standard*, Order No. 733, P150, 130 FERC ¶ 61,221 (2010) (“Order No. 733”).

required to achieve the necessary milestones including scheduling a special call for NERC Board adoption, while still allowing NERC and the industry to successfully meet the filing deadline.

## Standard Development Timeline

*This section is maintained by the drafting team during the development of the standard and will be removed when the standard becomes effective.*

### Development Steps Completed

1. Standards Authorization Request (SAR) posted for comment from August 19, 2010 through September 19, 2010.
2. Standards Committee (SC) authorized moving the SAR forward into standard development on August 12, 2010.
3. SC authorized initial posting of Draft 1 on April 24, 2014.
4. Draft 1 of PRC-026-1 was posted for a 45-day formal comment period from April 25 – June 9, 2014 with a concurrent/parallel initial ballot in the last ten days of the comment period from May 30 – June 9, 2014.
5. Draft 2 of PRC-026-1 was posted for an additional 45-day formal comment period from August 22 – October 6, 2014 with a concurrent/parallel additional ballot in the last ten days of the comment period from September 26 – October 6, 2014.
6. SC authorized a waiver of the Standards Process Manual on October 22, 2014 to reduce the Draft 3 additional formal comment period of PRC-026-1 from 45 days to 21 days with a concurrent/additional ballot period in the last ten days of the comment period.

### Description of Current Draft

The Protection System Response to Power Swings Standard Drafting Team (PSRPS SDT) is posting Draft 3 of PRC-026-1 – Relay Performance During Stable Power Swings for a 21-day additional comment period and concurrent/parallel additional ballot in the last ten days of the comment period.

Anticipated Actions	Anticipated Date
45-day Formal Comment Period with Concurrent/Parallel Initial 10-day Ballot	April 2014
45-day Formal Comment Period with Concurrent/Parallel Additional 10-day Ballot	August 2014
21-day Formal Comment Period with Concurrent/Parallel Additional 10-day Ballot (Standards Committee authorized a waiver of the Standards Process Manual, October 22, 2014)	October 2014

## PRC-026-1 — Relay Performance During Stable Power Swings

---

Final Ballot	December 2014
NERC Board of Trustees Adoption	December 2014

### Version History

Version	Date	Action	Change Tracking
1.0	TBD	Effective Date	New



### **Definitions of Terms Used in Standard**

*This section includes all newly defined or revised terms used in the proposed standard. Terms already defined in the Glossary of Terms Used in Reliability Standards (Glossary) are not repeated here. New or revised definitions listed below become approved when the proposed standard is approved. When the standard becomes effective, these defined terms will be removed from the individual standard and added to the Glossary.*

**Term:** None.

*When this standard has received ballot approval, the rationale boxes will be moved to the Application Guidelines Section of the standard.*

### A. Introduction

- 1. Title:** Relay Performance During Stable Power Swings
- 2. Number:** PRC-026-1
- 3. Purpose:** To ensure that load-responsive protective relays are expected to not trip in response to stable power swings during non-Fault conditions.
- 4. Applicability:**
  - 4.1. Functional Entities:**
    - 4.1.1** Generator Owner that applies load-responsive protective relays as described in PRC-026-1 – Attachment A at the terminals of the Elements listed in Section 4.2, Facilities.
    - 4.1.2** Planning Coordinator.
    - 4.1.3** Transmission Owner that applies load-responsive protective relays as described in PRC-026-1 – Attachment A at the terminals of the Elements listed in Section 4.2, Facilities.
  - 4.2. Facilities:** The following Elements that are part of the Bulk Electric System (BES):
    - 4.2.1** Generators.
    - 4.2.2** Transformers.
    - 4.2.3** Transmission lines.

### 5. Background:

This is the third phase of a three-phased standard development project that focused on developing this new Reliability Standard to address protective relay operations due to stable power swings. The March 18, 2010, Federal Energy Regulatory Commission (FERC) Order No. 733, approved Reliability Standard PRC-023-1 – Transmission Relay Loadability. In this Order, FERC directed NERC to address three areas of relay loadability that include modifications to the approved PRC-023-1, development of a new Reliability Standard to address generator protective relay loadability, and a new Reliability Standard to address the operation of protective relays due to stable power swings. This project's SAR addresses these directives with a three-phased approach to standard development.

Phase 1 focused on making the specific modifications to PRC-023-1 and was completed in the approved Reliability Standard PRC-023-2, which became mandatory on July 1, 2012.

Phase 2 focused on developing a new Reliability Standard, PRC-025-1 – Generator Relay Loadability, to address generator protective relay loadability. PRC-025-1 became mandatory on October 1, 2014 along with PRC-023-3, which was modified to harmonize PRC-023-2 with PRC-025-1.

Phase 3 of the project establishes Requirements aimed at preventing protective relays from tripping unnecessarily due to stable power swings by requiring the identification of Elements on which a stable or unstable power swing may affect Protection System operation, and to develop Requirements to assess the security of load-responsive protective relays to tripping in response to only a stable power swing. Last, to require entities to implement Corrective Action Plans (CAP), where necessary, to improve security of load-responsive protective relays for stable power swings so they are expected to not trip in response to stable power swings during non-Fault conditions, while maintaining dependable fault detection and dependable out-of-step tripping.

**6. Effective Dates:**

**Requirement R1**

First day of the first full calendar year that is 12 months after the date that the standard is approved by an applicable governmental authority or as otherwise provided for in a jurisdiction where approval by an applicable governmental authority is required for a standard to go into effect. Where approval by an applicable governmental authority is not required, the standard shall become effective on the first day of the first full calendar year that is 12 months after the date the standard is adopted by the NERC Board of Trustees or as otherwise provided for in that jurisdiction.

**Requirements R2, R3, and R4**

First day of the first full calendar year that is 36 months after the date that the standard is approved by an applicable governmental authority or as otherwise provided for in a jurisdiction where approval by an applicable governmental authority is required for a standard to go into effect. Where approval by an applicable governmental authority is not required, the standard shall become effective on the first day of the first full calendar year that is 36 months after the date the standard is adopted by the NERC Board of Trustees or as otherwise provided for in that jurisdiction.

## B. Requirements and Measures

**R1.** Each Planning Coordinator shall, at least once each calendar year, provide notification of each generator, transformer, and transmission line BES Element in its area that meet one or more of the following criteria, if any, to the respective Generator Owner and Transmission Owner: [*Violation Risk Factor: Medium*] [*Time Horizon: Long-term Planning*]

Criteria:

1. Generator(s) where an angular stability constraint exists that is addressed by a System Operating Limit (SOL) or a Remedial Action Scheme (RAS) and those Elements terminating at the Transmission station associated with the generator(s).
2. An Element that is monitored as part of a SOL identified by the Planning Coordinator's methodology<sup>1</sup> based on an angular stability constraint.
3. An Element that forms the boundary of an island in the most recent underfrequency load shedding (UFLS) design assessment based on application of the Planning Coordinator's criteria for identifying islands, where the island is formed by tripping the Element due to angular instability.
4. An Element identified in the most recent annual Planning Assessment where relay tripping occurs due to a stable or unstable power swing during a simulated disturbance.

**M1.** Each Planning Coordinator shall have dated evidence that demonstrates notification of the generator, transformer, and transmission line BES Element(s) that meet one or more of the criteria in Requirement R1, if any, to the respective Generator Owner and Transmission Owner. Evidence may include, but is not limited to, the following documentation: emails, facsimiles, records, reports, transmittals, lists, or spreadsheets.

**Rationale for R1:** The Planning Coordinator has a wide-area view and is in the position to identify generator, transformer, and transmission line BES Elements which meet the criteria, if any. The criteria-based approach is consistent with the NERC System Protection and Control Subcommittee (SPCS) technical document *Protection System Response to Power Swings*, August 2013 ("PSRPS Report"),<sup>2</sup> which recommends a focused approach to determine an at-risk BES Element. See the Guidelines and Technical Basis for a detailed discussion of the criteria.

---

<sup>1</sup> NERC Reliability Standard FAC-10 – System Operating Limits Methodology for the Planning Horizon

<sup>2</sup> NERC System Protection and Control Subcommittee, *Protection System Response to Power Swings*, August 2013: [http://www.nerc.com/comm/PC/System%20Protection%20and%20Control%20Subcommittee%20SPCS%2020/SPCS%20Power%20Swing%20Report\\_Final\\_20131015.pdf](http://www.nerc.com/comm/PC/System%20Protection%20and%20Control%20Subcommittee%20SPCS%2020/SPCS%20Power%20Swing%20Report_Final_20131015.pdf)

- R2.** Each Generator Owner and Transmission Owner shall determine: [Violation Risk Factor: High] [Time Horizon: Operations Planning]
- 2.1** Within 12 full calendar months of notification of a BES Element pursuant to Requirement R1, determine whether its load-responsive protective relay(s) applied to that BES Element meets the criteria in PRC-026-1 – Attachment B where an evaluation of that Element’s load-responsive protective relay(s) based on PRC-026-1 – Attachment B criteria has not been performed in the last five calendar years.
- 2.2** Within 12 full calendar months of becoming aware of a generator, transformer, or transmission line BES Element that tripped in response to a stable or unstable power swing due to the operation of its protective relay(s), determine whether its load-responsive protective relay(s) applied to that BES Element meets the criteria in PRC-026-1 – Attachment B.
- M2.** Each Generator Owner and Transmission Owner shall have dated evidence that demonstrates the evaluation was performed according to Requirement R2. Evidence may include, but is not limited to, the following documentation: apparent impedance characteristic plots, email, design drawings, facsimiles, R-X plots, software output, records, reports, transmittals, lists, settings sheets, or spreadsheets.

**Rationale for R2:** The Generator Owner and Transmission Owner are in a position to determine whether its load-responsive protective relays meet the PRC-026-1 – Attachment B criteria. Generator, transformer, and transmission line BES Elements are identified by the Planning Coordinator in Requirement R1 and by the Generator Owner and Transmission Owner following an actual event where the Generator Owner and Transmission Owner became aware (i.e., through an event analysis or Protection System review) tripping was due to stable or unstable power swing. A period of 12 calendar months allows sufficient time for protection staff to conduct the evaluation.

- R3.** Each Generator Owner and Transmission Owner shall, within six full calendar months of determining a load-responsive protective relay does not meet the PRC-026-1 – Attachment B criteria, develop a Corrective Action Plan (CAP) to meet one or more of the following [*Violation Risk Factor: Medium*] [*Time Horizon: Operations Planning*]
- The Protection System meets the PRC-026-1 – Attachment B criteria, while maintaining dependable fault detection and dependable out-of-step tripping (if out-of-step tripping is applied at the terminal of the BES Element); or
  - The Protection System is excluded under the PRC-026-1 – Attachment A criteria (e.g., modifying the Protection System so that relay functions are supervised by power swing blocking or using relay systems that are immune to power swings), while maintaining dependable fault detection and dependable out-of-step tripping (if out-of-step tripping is applied at the terminal of the BES Element).
- M3.** The Generator Owner and Transmission Owner shall have dated evidence that demonstrates the development of a CAP in accordance with Requirement R3. Evidence may include, but is not limited to, the following documentation: corrective action plans, maintenance records, settings sheets, project or work management program records, or work orders.

**Rationale for R3:** To meet the reliability purpose of the standard, a CAP is necessary to ensure the entity’s Protection System meets the PRC-026-1 – Attachment B criteria so that protective relays are expected to not trip in response to stable power swings. The phrase, “...while maintaining dependable fault detection and dependable out-of-step tripping...” in Requirement R2 describes that the entity is to comply with this standard, while achieving their desired protection goals. Refer to the Guidelines and Technical Basis, Introduction, for more information.

- R4.** Each Generator Owner and Transmission Owner shall implement each CAP developed pursuant to Requirement R3 and update each CAP if actions or timetables change until all actions are complete. [*Violation Risk Factor: Medium*][*Time Horizon: Long-Term Planning*]
- M4.** The Generator Owner and Transmission Owner shall have dated evidence that demonstrates implementation of each CAP according to Requirement R4, including updates to the CAP when actions or timetables change. Evidence may include, but is not limited to, the following documentation: corrective action plans, maintenance records, settings sheets, project or work management program records, or work orders.

**Rationale for R4:** Implementation of the CAP must accomplish all identified actions to be complete to achieve the desired reliability goal. During the course of implementing a CAP, updates may be necessary for a variety of reasons such as new information, scheduling conflicts, or resource issues. Documenting CAP changes and completion of activities provides measurable progress and confirmation of completion.

## C. Compliance

### 1. Compliance Monitoring Process

#### 1.1. Compliance Enforcement Authority

As defined in the NERC Rules of Procedure, “Compliance Enforcement Authority” (CEA) means NERC or the Regional Entity in their respective roles of monitoring and enforcing compliance with the NERC Reliability Standards.

#### 1.2. Evidence Retention

The following evidence retention periods identify the period of time an entity is required to retain specific evidence to demonstrate compliance. For instances where the evidence retention period specified below is shorter than the time since the last audit, the CEA may ask an entity to provide other evidence to show that it was compliant for the full time period since the last audit.

The Generator Owner, Planning Coordinator, and Transmission Owner shall keep data or evidence to show compliance as identified below unless directed by its CEA to retain specific evidence for a longer period of time as part of an investigation.

- The Planning Coordinator shall retain evidence of Requirement R1 for a minimum of one calendar year following the completion of the Requirement.
- The Generator Owner and Transmission Owner shall retain evidence of Requirement R2 evaluation for a minimum of 12 calendar months following completion of each evaluation where a CAP is not developed.
- The Generator Owner and Transmission Owner shall retain evidence of Requirements R2, R3 and R4 for a minimum of 12 calendar months following completion of each CAP.

If a Generator Owner, Planning Coordinator, or Transmission Owner is found non-compliant, it shall keep information related to the non-compliance until mitigation is complete and approved, or for the time specified above, whichever is longer.

The CEA shall keep the last audit records and all requested and submitted subsequent audit records.

#### 1.3. Compliance Monitoring and Assessment Processes:

As defined in the NERC Rules of Procedure; “Compliance Monitoring and Assessment Processes” refers to the identification of the processes that will be used to evaluate data or information for the purpose of assessing performance or outcomes with the associated reliability standard.

#### 1.4. Additional Compliance Information

None.

Table of Compliance Elements

R#	Time Horizon	VRF	Violation Severity Levels			
			Lower VSL	Moderate VSL	High VSL	Severe VSL
R1	Long-term Planning	Medium	The Planning Coordinator provided notification of the BES Element(s) in accordance with Requirement R1, but was less than or equal to 30 calendar days late.	The Planning Coordinator provided notification of the BES Element(s) in accordance with Requirement R1, but was more than 30 calendar days and less than or equal to 60 calendar days late.	The Planning Coordinator provided notification of the BES Element(s) in accordance with Requirement R1, but was more than 60 calendar days and less than or equal to 90 calendar days late.	The Planning Coordinator provided notification of the BES Element(s) in accordance with Requirement R1, but was more than 90 calendar days late.  OR  The Planning Coordinator failed to provide notification of the BES Element(s) in accordance with Requirement R1.



R#	Time Horizon	VRF	Violation Severity Levels			
			Lower VSL	Moderate VSL	High VSL	Severe VSL
<b>R2</b>	Operations Planning	High	The Generator Owner or Transmission Owner evaluated its load-responsive protective relay(s) in accordance with Requirement R2, but was less than or equal to 30 calendar days late.	The Generator Owner or Transmission Owner evaluated its load-responsive protective relay(s) in accordance with Requirement R2, but was more than 30 calendar days and less than or equal to 60 calendar days late.	The Generator Owner or Transmission Owner evaluated its load-responsive protective relay(s) in accordance with Requirement R2, but was more than 60 calendar days and less than or equal to 90 calendar days late.	The Generator Owner or Transmission Owner evaluated its load-responsive protective relay(s) in accordance with Requirement R2, but was more than 90 calendar days late.  OR The Generator Owner or Transmission Owner failed to evaluate its load-responsive protective relay(s) in accordance with Requirement R2.

R#	Time Horizon	VRF	Violation Severity Levels			
			Lower VSL	Moderate VSL	High VSL	Severe VSL
<b>R3</b>	Long-term Planning	Medium	The Generator Owner or Transmission Owner developed a Corrective Action Plan (CAP) in accordance with Requirement R3, but in more than six calendar months and less than or equal to seven calendar months.	The Generator Owner or Transmission Owner developed a Corrective Action Plan (CAP) in accordance with Requirement R3, but in more than seven calendar months and less than or equal to eight calendar months.	The Generator Owner or Transmission Owner developed a Corrective Action Plan (CAP) in accordance with Requirement R3, but in more than eight calendar months and less than or equal to nine calendar months.	The Generator Owner or Transmission Owner developed a Corrective Action Plan (CAP) in accordance with Requirement R3, but in more than nine calendar months.  OR The Generator Owner or Transmission Owner failed to develop a CAP in accordance with Requirement R3.
<b>R4</b>	Long-term Planning	Medium	The Generator Owner or Transmission Owner implemented a Corrective Action Plan (CAP), but failed to update a CAP when actions or timetables changed, in accordance with Requirement R4.	N/A	N/A	The Generator Owner or Transmission Owner failed to implement a Corrective Action Plan (CAP) in accordance with Requirement R4.

#### D. Regional Variances

None.

#### E. Interpretations

None.

#### F. Associated Documents

*Applied Protective Relaying*, Westinghouse Electric Corporation, 1979.

Burdy, John, *Loss-of-excitation Protection for Synchronous Generators GER-3183*, General Electric Company.

IEEE Power System Relaying Committee WG D6, *Power Swing and Out-of-Step Considerations on Transmission Lines*, July 2005: <http://www.pes-psrc.org/Reports/Power%20Swing%20and%20OOS%20Considerations%20on%20Transmission%20Lines%20F..pdf>.

Kimbark Edward Wilson, *Power System Stability, Volume II: Power Circuit Breakers and Protective Relays*, Published by John Wiley and Sons, 1950.

Kundur, Prabha, *Power System Stability and Control*, 1994, Palo Alto: EPRI, McGraw Hill, Inc.

NERC System Protection and Control Subcommittee, *Protection System Response to Power Swings*, August 2013: [http://www.nerc.com/comm/PC/System%20Protection%20and%20Control%20Subcommittee%20SPCS%2020/SPCS%20Power%20Swing%20Report\\_Final\\_20131015.pdf](http://www.nerc.com/comm/PC/System%20Protection%20and%20Control%20Subcommittee%20SPCS%2020/SPCS%20Power%20Swing%20Report_Final_20131015.pdf).

Reimert, Donald, *Protective Relaying for Power Generation Systems*, 2006, Boca Raton: CRC Press.

**PRC-026-1 – Attachment A**

This standard applies to any protective functions which could trip instantaneously or with a time delay of less than 15 cycles on load current (i.e., “load-responsive”) including, but not limited to:

- Phase distance
- Phase overcurrent
- Out-of-step tripping
- Loss-of-field

The following protection functions are excluded from Requirements of this standard:

- Relay elements supervised by power swing blocking
- Relay elements that are only enabled when other relays or associated systems fail. For example:
  - Overcurrent elements that are only enabled during loss of potential conditions.
  - Relay elements that are only enabled during a loss of communications
- Thermal emulation relays which are used in conjunction with dynamic Facility Ratings
- Relay elements associated with direct current (dc) lines
- Relay elements associated with dc converter transformers
- Phase fault detector relay elements employed to supervise other load-responsive phase distance elements (e.g., in order to prevent false operation in the event of a loss of potential) provided the distance element is set in accordance with the criteria outlined in the standard
- Relay elements associated with switch-onto-fault schemes
- Reverse power relay on the generator
- Generator relay elements that are armed only when the generator is disconnected from the system, (e.g., non-directional overcurrent elements used in conjunction with inadvertent energization schemes, and open breaker flashover schemes)
- Current differential relay, pilot wire relay, and phase comparison relay
- Voltage-restrained or voltage-controlled overcurrent relays

## PRC-026-1 – Attachment B

### Criteria A:

An impedance-based relay used for tripping is expected to not trip for a stable power swing, when the relay characteristic is completely contained within the unstable power swing region.<sup>3</sup> The unstable power swing region is formed by the union of three shapes in the impedance (R-X) plane; (1) a lower loss-of-synchronism circle based on a ratio of the sending-end to receiving-end voltages of 0.7; (2) an upper loss-of-synchronism circle based on a ratio of the receiving-end to sending-end voltages of 1.43; (3) a lens that connects the endpoints of the total system impedance (with the parallel transfer impedance removed) bounded by varying the sending-end and receiving-end voltages from 0.0 to 1.0 per unit, while maintaining a constant system separation angle across the total system impedance where:

1. The system separation angle is:
  - At least 120 degrees, or
  - An angle less than 120 degrees where a documented transient stability analysis demonstrates that the expected maximum stable separation angle is less than 120 degrees.
2. All generation is in service and all transmission BES Elements are in their normal operating state when calculating the system impedance.
3. Saturated (transient or sub-transient) reactance is used for all machines.

**Rationale for Attachment B (Criteria A):** The PRC-026-1 – Attachment B, Criteria A provides a basis for determining if the relays are expected to not trip for a stable power swing having a system separation angle of up to 120 degrees with the sending-end and receiving-end voltages varying from 0.7 to 1.0 per unit (See Guidelines and Technical Basis).

---

<sup>3</sup> Guidelines and Technical Basis, Figures 1 and 2.

## PRC-026-1 – Attachment B

### Criteria B:

The pickup of an overcurrent relay element used for tripping, that is above the calculated current value (with the parallel transfer impedance removed) for the conditions below:

1. The system separation angle is:
  - At least 120 degrees, or
  - An angle less than 120 degrees where a documented transient stability analysis demonstrates that the expected maximum stable separation angle is less than 120 degrees.
2. All generation is in service and all transmission BES Elements are in their normal operating state when calculating the system impedance.
3. Saturated (transient or sub-transient) reactance is used for all machines.
4. Both the sending-end and receiving-end voltages at 1.05 per unit.

**Rationale for Attachment B (Criteria B):** The PRC-026-1 – Attachment B, Criteria B provides a basis for determining if the relays are expected to not trip for a stable power swing having a system separation angle of up to 120 degrees with the sending-end and receiving-end voltages at 1.05 per unit (See Guidelines and Technical Basis).

### Guidelines and Technical Basis

#### Introduction

The NERC System Protection and Control Subcommittee technical document, *Protection System Response to Power Swings*, August 2013<sup>4</sup> (“PSRPS Report” or “report”) was specifically prepared to support the development of this NERC Reliability Standard. The report provided a historical perspective on power swings as early as 1965 up through the approval of the report by the NERC Planning Committee. The report also addresses reliability issues regarding trade-offs between security and dependability of Protection Systems, considerations for this NERC Reliability Standard, and a collection of technical information about power swing characteristics and varying issues with practical applications and approaches to power swings. Of these topics, the report suggests an approach for this NERC Reliability Standard (“standard” or “PRC-026-1”) which is consistent with addressing two of the three regulatory directives in the FERC Order No. 733. The first directive concerns the need for “...protective relay systems that differentiate between faults and stable power swings and, when necessary, phases out protective relay systems that cannot meet this requirement.”<sup>5</sup> Second, is “...to develop a Reliability Standard addressing undesirable relay operation due to stable power swings.”<sup>6</sup> The third directive “...to consider “islanding” strategies that achieve the fundamental performance for all islands in developing the new Reliability Standard addressing stable power swings”<sup>7</sup> was considered during development of the standard.

The development of this standard implements the majority of the approaches suggested by the report. However, it is noted that the Reliability Coordinator and Transmission Planner have not been included in the standard’s Applicability section (as suggested by the PSRPS Report). This is so that a single entity, the Planning Coordinator, may be the single source for identifying Elements according to Requirement R1. A single source will insure that multiple entities will not identify Elements in duplicate, nor will one entity fail to provide an Element because it believes the Element is being provided by another entity. The Planning Coordinator has, or has access to, the wide-area model and can correctly identify the Elements that may be susceptible to a stable or unstable power swing. Additionally, not including the Reliability Coordinator and Transmission Planner is consistent with the applicability of other relay loadability NERC Reliability Standards (e.g., PRC-023 and PRC-025). It is also consistent with the NERC Functional Model.

The phrase, “while maintaining dependable fault detection and dependable out-of-step tripping” in Requirement R2, describes that the Generator Owner and Transmission Owner is to comply with this standard, while achieving its desired protection goals. Load-responsive protective relays, as addressed within this standard, may be intended to provide a variety of backup protection functions, both within the generating unit or generating plant and on the transmission system, and

---

<sup>4</sup> NERC System Protection and Control Subcommittee, *Protection System Response to Power Swings*, August 2013: [http://www.nerc.com/comm/PC/System%20Protection%20and%20Control%20Subcommittee%20SPCS%2020/SPCS%20Power%20Swing%20Report\\_Final\\_20131015.pdf](http://www.nerc.com/comm/PC/System%20Protection%20and%20Control%20Subcommittee%20SPCS%2020/SPCS%20Power%20Swing%20Report_Final_20131015.pdf)

<sup>5</sup> Transmission Relay Loadability Reliability Standard, Order No. 733, P.150 FERC ¶ 61,221 (2010).

<sup>6</sup> Ibid. P.153.

<sup>7</sup> Ibid. P.162.

this standard is not intended to result in the loss of these protection functions. Instead, it is suggested that the Generator Owner and Transmission Owner consider both the Requirements within this standard and its desired protection goals, and perform modifications to its protective relays or protection philosophies as necessary to achieve both.

### Power Swings

The IEEE Power System Relaying Committee WG D6 developed a technical document called *Power Swing and Out-of-Step Considerations on Transmission Lines* (July 2005) that provides background on power swings. The following are general definitions from that document:<sup>8</sup>

**Power Swing:** a variation in three phase power flow which occurs when the generator rotor angles are advancing or retarding relative to each other in response to changes in load magnitude and direction, line switching, loss of generation, faults, and other system disturbances.

**Pole Slip:** a condition whereby a generator, or group of generators, terminal voltage angles (or phases) go past 180 degrees with respect to the rest of the connected power system.

**Stable Power Swing:** a power swing is considered stable if the generators do not slip poles and the system reaches a new state of equilibrium, i.e. an acceptable operating condition.

**Unstable Power Swing:** a power swing that will result in a generator or group of generators experiencing pole slipping for which some corrective action must be taken.

**Out-of-Step Condition:** Same as an unstable power swing.

**Electrical System Center or Voltage Zero:** it is the point or points in the system where the voltage becomes zero during an unstable power swing.

### Burden to Entities

The PSRPS Report provides a technical basis and approach for focusing on Protection Systems, which are susceptible to power swings, while achieving the purpose of the standard. The approach reduces the number of relays to which the PRC-026-1 Requirements would apply by first identifying the BES Element(s) on which load-responsive protective relays must be evaluated. The first step uses criteria to identify the Elements on which a Protection System is expected to be challenged by power swings. Of those Elements, the second step is to evaluate each load-responsive protective relay that is applied on each identified Element. Rather than requiring the Planning Coordinator or Transmission Planner to perform simulations to obtain information for each identified Element, the Generator Owner and Transmission Owner will reduce the need for simulation by comparing the load-responsive protective relay characteristic to specific criteria in PRC-026-1 – Attachment B.

---

<sup>8</sup> <http://www.pes-psrc.org/Reports/Power%20Swing%20and%20OOS%20Considerations%20on%20Transmission%20Lines%20F..pdf>.



### Applicability

The standard is applicable to the Generator Owner, Planning Coordinator, and Transmission Owner entities. More specifically, the Generator Owner and Transmission Owner entities are applicable when applying load-responsive protective relays at the terminals of the applicable BES Elements. The standard is applicable to the following BES Elements: generators, transformers, and transmission lines. The Distribution Provider was considered for inclusion in the standard; however, it is not subject to the standard because this entity, by functional registration, would not own generators, transmission lines, or transformers other than load serving.

Load-responsive protective relays include any protective functions which could trip with or without time delay, on load current.

### Requirement R1

The Planning Coordinator has a wide-area view and is in the position to identify what, if any, Elements meet the criteria. The criterion-based approach is consistent with the NERC System Protection and Control Subcommittee (SPCS) technical document *Protection System Response to Power Swings* (August 2013),<sup>9</sup> which recommends a focused approach to determine an at-risk Element. Identification of Elements comes from the annual Planning Assessments pursuant to the transmission planning (i.e., “TPL”) and other NERC Reliability Standards (e.g., PRC-006), and the standard is not requiring any other assessments to be performed by the Planning Coordinator. The required notification on a calendar year basis to the respective Generator Owner and Transmission Owner is sufficient because it is expected that the Planning Coordinator will make its notifications following the completion of its annual Planning Assessments. The Planning Coordinator will continue to provide notification of Elements on a calendar year basis even if a study is performed less frequently (e.g., PRC-006 – Automatic Underfrequency Load Shedding, which is five years) and has not changed. It is possible that the Planning Coordinator provided notification of Elements in two different calendar years using the same annual Planning Assessment.

### Criterion 1

The first criterion involves generator(s) where an angular stability constraint exists that is addressed by a System Operating Limit (SOL) or a Remedial Action Scheme (RAS) and those Elements terminating at the Transmission station associated with the generator(s). For example, a scheme to remove generation for specific conditions is implemented for a four-unit generating plant (1,100 MW). Two of the units are 500 MW each; one is connected to the 345 kV system and one is connected to the 230 kV system. The Transmission Owner has two 230 kV transmission lines and one 345 kV transmission line all terminating at the generating facility as well as a 345/230 kV autotransformer. The remaining 100 MW consists of two 50 MW combustion turbine (CT) units connected to four 66 kV transmission lines. The 66 kV transmission line is not electrically joined to the 345 kV and 230 kV transmission lines at the plant site and is not a part of the operating

---

<sup>9</sup> [http://www.nerc.com/comm/PC/System%20Protection%20and%20Control%20Subcommittee%20SPCS%2020/SPCS%20Power%20Swing%20Report\\_Final\\_20131015.pdf](http://www.nerc.com/comm/PC/System%20Protection%20and%20Control%20Subcommittee%20SPCS%2020/SPCS%20Power%20Swing%20Report_Final_20131015.pdf)

limit or RAS. A stability constraint limits the output of the portion of the plant affected by the RAS to 700 MW for an outage of the 345 kV transmission line. The RAS trips one of the 500 MW units to maintain stability for a loss of the 345 kV transmission line when the total output from both 500 MW units is above 700 MW. For this example, both 500 MW generating units and the associated generator step-up (GSU) transformers would be identified as Elements meeting this criterion. The 345/230 kV autotransformer, the 345 kV transmission line, and the two 230 kV transmission lines would also be identified as Elements meeting this criterion. The 50 MW combustion turbines and 66 kV transmission lines would not be identified pursuant to Criterion 1 because these Elements are not subject to an operating limit or RAS and do not terminate at the Transmission station associated with the generators that are subject to the SOL or RAS.

### Criterion 2

The second criterion involves Elements that are monitored as a part of an established System Operating Limit (SOL) based on an angular stability limit regardless of the outage conditions that result in the enforcement of the SOL. For example, if two long parallel 500 kV transmission lines have a combined SOL of 1,200 MW, and this limit is based on angular instability resulting from a fault and subsequent loss of one of the two lines, then both lines would be identified as an Element meeting the criterion.

### Criterion 3

The third criterion involves Elements that form the boundary of an island within an underfrequency load shedding (UFLS) design assessment. The criterion applies to islands identified based on application of the Planning Coordinator's criteria for identifying islands, where the island is formed by tripping the Elements based on angular instability. The criterion applies if the angular instability is modeled in the UFLS design assessment, or if the boundary is identified "off-line" (i.e., the Elements are selected based on angular instability considerations, but the Elements are tripped in the UFLS design assessment without modeling the initiating angular instability). In cases where an out-of-step condition is detected and tripping is initiated at an alternate location, the criterion applies to the Element on which the power swing is detected. The criterion does not apply to islands identified based on other considerations that do not involve angular instability, such as excessive loading.

### Criterion 4

The fourth criterion involves Elements identified in the most recent annual Planning Assessment where relay tripping occurs due to a stable or unstable power swing during a simulated disturbance. The intent is for the Planning Coordinator to include any Element(s) where relay tripping was observed during simulations performed for the most recent annual Planning Assessment associated with the transmission planning TPL-001-4 Reliability Standard. Note that relay tripping must be assessed within those annual Planning Assessments per TPL-001-4, R4, Part 4.3.1.3, which indicates that analysis shall include the "Tripping of Transmission lines and transformers where transient swings cause Protection System operation based on generic or actual relay models." Identifying such Elements according to Criterion 4 and notifying the respective Generator Owner and Transmission Owner will require that the owners of any load-responsive protective relay

applied at the terminals of the identified Element evaluate the relay's susceptibility to tripping in response a stable power swing.

Planning Coordinators have discretion to determine whether observed tripping for a power swing in its Planning Assessments occurs for valid contingencies and system conditions. The Planning Coordinator will address tripping that is observed in transient analyses on an individual basis; therefore, the Planning Coordinator is responsible for identifying the Elements based only on simulation results that are determined to be valid.

Due to the nature of how a Planning Assessment is performed, there may be cases where a previously-identified Element is not identified in the most recent annual Planning Assessment. If so, this is acceptable because the Generator Owner and Transmission Owner would have taken action upon the initial notification of the previously identified Element. When an Element is not identified in later Planning Assessments, the risk of load-responsive protective relays tripping in response to a stable power swing during non-Fault conditions would have already been assessed under Requirement R2 and mitigated according to Requirements R3 and R4 where the relays did not meet the PRC-026-1 – Attachment B criteria. According to Requirement R2, the Generator Owner and Transmission Owner are only required to re-evaluate each load-responsive protective relay for an identified Element where the evaluation has not been performed in the last five calendar years.

Although Requirement R1 requires the Planning Coordinator to notify the respective Generator Owner and Transmission Owner of any Elements meeting one or more of the four criteria, it does not preclude the Planning Coordinator from providing additional information, such as apparent impedance characteristics, in advance or upon request, that may be useful in evaluating protective relays. Generator Owners and Transmission Owners are able to complete protective relay evaluations and perform the required actions without additional information. The standard does not include any requirement for the entities to provide information that is already being shared or exchanged between entities for operating needs. While a Requirement has not been included for the exchange of information, entities should recognize that relay performance needs to be measured against the most current information.

### **Requirement R2**

Requirement R2 requires the Generator Owner and Transmission Owner to evaluate its load-responsive protective relays to ensure that they are expected to not trip in response to stable power swings.

## PRC-026-1 – Application Guidelines

---

The PRC-026-1 – Attachment A lists the applicable load-responsive relays that must be evaluated. These relays include phase distance, phase overcurrent, out-of-step tripping, and loss-of-field. Phase distance relays can include the following:

- Mho element characteristics such as Zone 1, Zone 2, or Zone 3 with intentional time delays of 15 cycles or less.
- Mho element characteristics that overreach the remote line terminal used in high-speed, communications assisted tripping schemes including:
  - Directional Comparison Blocking (DCB) schemes
  - Directional Comparison Un-Blocking (DCUB) schemes
  - Permissive Overreach Transfer Trip (POTT) schemes

A method is provided within the standard to support consistent evaluation by Generator Owners and Transmission Owners based on specified conditions. Once a Generator Owner or Transmission Owner is notified of Elements pursuant to Requirement R1, it has 12 full calendar months to determine if each Element's load-responsive protective relays meet the applicable PRC-026-1 – Attachment B criteria, if the determination has not been performed in the last five calendar years. Additionally, each Generator Owner and Transmission Owner, that becomes aware of a generator, transformer, or transmission line BES Element that tripped in response to a stable or unstable power swing due to the operation of its protective relays, must perform the same PRC-026-1 – Attachment B criteria determination within 12 full calendar months.

### **Becoming Aware of an Element That Tripped in Response to a Power Swing**

Part 2.2 in Requirement R2 is intended to initiate action by the Generator Owner and Transmission Owner when there is a known stable or unstable power swing and it resulted in the entity's Element tripping. The criterion starts with becoming aware of the event (i.e., power swing) and then any connection with the entity's Element tripping. By doing so, the focus is removed from the entity having to demonstrate that it performed a power swing analysis for every Element trip. The basis for structuring the criterion in this manner is driven by the available ways that a Generator Owner and Transmission Owner could become aware of an Element that tripped in response to a stable or unstable power swing due to the operation of its protective relay(s).

Element trips caused by stable or unstable power swings, though infrequent, would be more common in a larger event. The identification of power swings will be revealed during an analysis of the event. Event analysis could include internal analysis conducted by the entity, the entity's Protection System review following a trip, or a larger scale analysis which includes involvement by the entity's Regional Entity and in some cases NERC.

### **Information Common to Both Generation and Transmission Elements**

The PRC-026-1 – Attachment A lists the load-responsive protective relays that are subject to this standard. Generator Owners and Transmission Owners may own load-responsive protective relays (i.e., distance relays) that directly affect generation or transmission BES Elements and will require analysis as a result of Elements being identified by the Planning Coordinator in Requirement R1 or the Generator Owner or Transmission Owner in Requirement R2. For example, distance relays

owned by the Transmission Owner may be installed at the high-voltage side of the generator step-up (GSU) transformer (directional toward the generator) providing backup to generation protection. Generator Owners may have distance relays applied to backup transmission protection or backup protection to the GSU transformer. The Generator Owner may have relays installed at the generator terminals or the high-voltage side of the GSU transformer.

**Exclusion of Time Based Load-Responsive Protective Relays**

The purpose of the standard is “[t]o ensure that load-responsive protective relays are expected to not trip in response to stable power swings during non-Fault conditions.” Load-responsive, high-speed tripping protective relays pose the highest risk of operating during a power swing. Because of this, high-speed tripping protective relays and relays with a time delay of less than 15 cycles are included in the standard; whereas other relays (i.e., Zones 2 and 3) with a time a delay of 15 cycles or greater are excluded. The time delay used for exclusion on some load-responsive protective relays is recommended based on 1) the minimum time delay these relays are set in practice, and 2) the maximum expected time that load-responsive protective relays would be exposed to a stable power swing based on a swing rate.

In order to establish a time delay that distinguishes a high-risk load-responsive protective relay from one that has a time delay for tripping (lower-risk), a sample of swing rates were calculated based on a stable power swing entering and leaving the impedance characteristic as shown in Table 1. For a relay impedance characteristic that has the power swing entering and leaving beginning at 90 degrees with a termination at 120 degrees before exiting the zone, calculation of the timer must be greater than the time the stable swing is inside the relay operate zone.

Eq. (1) 
$$Zone\ time > 2 \times \left( \frac{(120^\circ - Angle\ of\ entry\ into\ the\ relay\ characteristic) \times 60}{(360 \times Slip\ Rate)} \right)$$

<b>Table 1. Swing Rates</b>	
<b>Zone Timer (Cycles)</b>	<b>Slip Rate (Hz)</b>
10	1.00
15	0.67
20	0.50
30	0.33

With a minimum zone timer of 15 cycles, the corresponding slip of the system is 0.67 Hz. This represents an approximation of a slow slip rate during a system Disturbance. Consequently, this

value corresponds to the typical minimum time delay used for Zone 2 distance relays in transmission line protection. Longer time delays allow for slower slip rates.

### Application to Transmission Elements

Criteria A in PRC-026-1 – Attachment B describes an unstable power swing region that is formed by the union of three shapes in the impedance (R-X) plane. The first shape is a lower loss of synchronism circle based on a ratio of the sending-end to receiving-end voltages of 0.7 (i.e.,  $E_S / E_R = 0.7 / 1.0 = 0.7$ ). The second shape is an upper loss of synchronism circle based on a ratio of the receiving-end to sending-end voltages of 1.43 (i.e.,  $E_R / E_S = 1.0 / 0.7 = 1.43$ ). The third shape is a lens that connects the endpoints of the total system impedance together by varying the sending-end and receiving-end system voltages from 0.0 to 1.0 per unit, while maintaining a constant system separation angle across the total system impedance (with the parallel transfer impedance removed—see Figures 1 through 5). The total system impedance is derived from a two-bus equivalent network and is determined by summing the sending-end source impedance, the line impedance (excluding the Thévenin equivalent transfer impedance), and the receiving-end source impedance as shown in Figures 6 and 7. The goal in establishing the total system impedance is to represent a conservative condition that will maximize the security of the relay against various system conditions. The smallest total system impedance represents a condition where the size of the lens characteristic in the R-X plane is smallest and is a conservative operating point from the standpoint of ensuring a load-responsive protective relay is expected to not trip given a predetermined angular displacement between the sending-end and receiving-end voltages. The smallest total system impedance results when all generation is in service and all transmission BES Elements are modeled in their “normal” system configuration (PRC-026-1 – Attachment B, Criteria A). The parallel transfer impedance is removed to represent a likely condition where parallel elements may be lost during the disturbance, and the loss of these elements magnifies the sensitivity of the load-responsive relays on the parallel line by removing the “infeed effect” (i.e., the apparent impedance sensed by the relay is decreased as a result of the loss of the transfer impedance, thus making the relay more likely to trip for a stable power swing—See Figures 13 and 14).

The sending-end and receiving-end source voltages are varied from 0.7 to 1.0 per unit to form the lower and upper loss of synchronism circles. The ratio of these two voltages is used in the calculation of the loss of synchronism circles, and result in a ratio range from 0.7 to 1.43.

$$\text{Eq. (2)} \quad \frac{E_S}{E_R} = \frac{0.7}{1.0} = 0.7$$

$$\text{Eq. (3):} \quad \frac{E_R}{E_S} = \frac{1.0}{0.7} = 1.43$$

The internal generator voltage during severe power swings or transmission system fault conditions will be greater than zero, due to voltage regulator support. The voltage ratio of 0.7 to 1.43 is chosen to be more conservative than the PRC-023<sup>10</sup> and PRC-025<sup>11</sup> NERC Reliability Standards, where a lower bound voltage of 0.85 per unit voltage is used. A  $\pm 15\%$  internal generator voltage range

---

<sup>10</sup> Transmission Relay Loadability

<sup>11</sup> Generator Relay Loadability

was chosen as a conservative voltage range for calculation of the voltage ratio used to calculate the loss of synchronism circles. For example, the voltage ratio using these voltages would result in a ratio range from 0.739 to 1.353.

$$\text{Eq. (4)} \quad \frac{E_S}{E_R} = \frac{0.85}{1.15} = 0.739$$

$$\text{Eq. (5):} \quad \frac{E_R}{E_S} = \frac{1.15}{0.85} = 1.353$$

The lower ratio is rounded down to 0.7 to be more conservative, allowing a voltage range of 0.7 to 1.0 per unit to be used for the calculation of the loss of synchronism circles.<sup>12</sup>

When the parallel transfer impedance is included in the model, the split in current through the parallel transfer impedance path results in actual measured relay impedances that are larger than those measured when the parallel transfer impedance is removed (i.e., infeed effect), which would make it more likely for an impedance relay element to be completely contained within the unstable power swing region in Figure 11. If the transfer impedance is included in the evaluation, a distance relay element could be deemed as meeting PRC-026-1 – Attachment B and, in fact would be secure, assuming all elements were in their normal state. In this case, the distance relay element could trip for a stable power swing during an actual event if the system was weakened (i.e., a higher transfer impedance) by the loss of a subset of lines that make up the parallel transfer impedance. This could happen because the subset of lines that make up the parallel transfer impedance tripped on unstable swings, contained the initiating fault, and/or were lost due to operation of breaker failure or remote back-up protection schemes in Figure 10.

Table 10 shows the percent size increase of the lens shape as seen by the relay under evaluation when the parallel transfer impedance is included. The parallel transfer impedance has minimal effect on the apparent size of the lens shape as long as the parallel transfer impedance is at least 10 multiples of the parallel line impedance (less than 5% lens shape expansion), therefore, its removal has minimal impact, but results in a slightly more conservative, smaller lens shape. Transfer impedances of 5 multiples of the parallel line impedance or less result in an apparent lens shape size of 10% or greater as seen by the relay. If two parallel lines and a parallel transfer impedance tie the sending-end and receiving-end buses together, the total parallel transfer impedance will be one or less multiples of the parallel line impedance, resulting in an apparent lens shape size of 45% or greater. It is a realistic contingency that the parallel line could be out-of-service, leaving the transfer impedance making up the rest of the system in parallel with the line impedance. Since it is not known exactly which lines making up the parallel transfer impedance that will be out of service during a major system disturbance, it is most conservative to assume that all of them are out, leaving just the line under evaluation in service.

Either the saturated transient or sub-transient direct axis reactance values may be used for machines in the evaluation because they are smaller than un-saturated reactance values. Since sub-transient saturated generator reactances are smaller than the transient or synchronous reactance, they result in a smaller source impedance and a smaller unstable power swing region in the graphical analysis

---

<sup>12</sup> *Final Report on the August 14, 2003 Blackout in the United States and Canada: Causes and Recommendations*, April 2004, Section 6 (The Cascade Stage of the Blackout), p. 94 under “Why the Generators Tripped Off,” states, “Some generator undervoltage relays were set to trip at or above 90% voltage. However, a motor stalls out at about 70% voltage and a motor starter contactor drops out around 75%, so if there is a compelling need to protect the turbine from the system the under-voltage trigger point should be no higher than 80%.”

as shown in Figures 8 and 9. Since power swings occur in a time frame where generator transient reactances will be prevalent, it is acceptable to use saturated transient reactances instead of saturated sub-transient reactance values. Some short-circuit models may not include transient reactance values, so in this case, the use of sub-transient is acceptable because it also produces more conservative results than transient reactances. For this reason, either value is acceptable when determining the system source impedances (PRC-026-1 – Attachment B, Criteria A and B, No. 3).

Saturated reactance values are also the values used in short-circuit programs that produce the system impedance mentioned above. Planning and stability software generally use the un-saturated reactance values. Generator models used in transient stability analyses recognize that the extent of the saturation effect depends upon both rotor (field) and stator currents. Accordingly, they derive the effective saturated parameters of the machine at each instant by internal calculation from the specified (constant) unsaturated values of machine reactances and the instantaneous internal flux level. The specific assumptions regarding which inductances are affected by saturation, and the relative effect of that saturation, are different for the various generator models used. Thus, unsaturated values of all machine reactances are used in setting up planning and stability software data, and the appropriate set of open-circuit magnetization curve data is provided for each machine.

Saturated reactance values are smaller than unsaturated reactance values and are used in short-circuit programs owned by the Generator and Transmission Owners. Because of this, saturated reactance values are to be used in the development of the system source impedances.

The source or system equivalent impedances can be obtained by a number of different methods using commercially available short-circuit calculation tools.<sup>13</sup> Most short-circuit tools have a network reduction feature that allows the user to select the local and remote terminal buses to retain. The first method reduces the system to one that contains two buses, an equivalent generator at each bus (representing the source impedance at the sending-end and receiving-ends), and two parallel lines; one being the line impedance of the protected line with relays being analyzed, the other being the transfer impedance representing all other combinations of lines that connect the two buses together as shown in Figure 6. Another conservative method is to open both ends of the line in question, and apply a three-phase bolted fault at each bus. The resulting source impedance at each end will be less than or equal to the actual source impedance calculated by the network reduction method. Either method can be used to develop the system source impedances at both ends.

The two bullets of PRC-026-1 – Attachment B, Criteria A, No. 1, identify the system separation angles to identify the size of the power swing stability boundary to be used to test load-responsive protective relay impedance elements. Both bullets test impedance relay elements that are not supervised by power swing blocking (PSB). The first bullet of PRC-026-1 – Attachment B, Criteria A, No. 1 evaluates a system separation angle of at least 120 degrees that is held constant while varying the sending-end and receiving-end source voltages from 0.7 to 1.0 per unit, thus creating an unstable power swing region about the total system impedance in Figure 1. This unstable power swing region is compared to the tripping portion of the distance relay characteristic; that is, the portion that is not supervised by load encroachment, blinders, or some other form of supervision as shown in Figure 12 that restricts the distance element from tripping for heavy, balanced load

---

<sup>13</sup> Demetrios A. Tziouvaras and Daqing Hou, Appendix in *Out-Of-Step Protection Fundamentals and Advancements*, April 17, 2014: <https://www.selinc.com>.



## PRC-026-1 – Application Guidelines

---

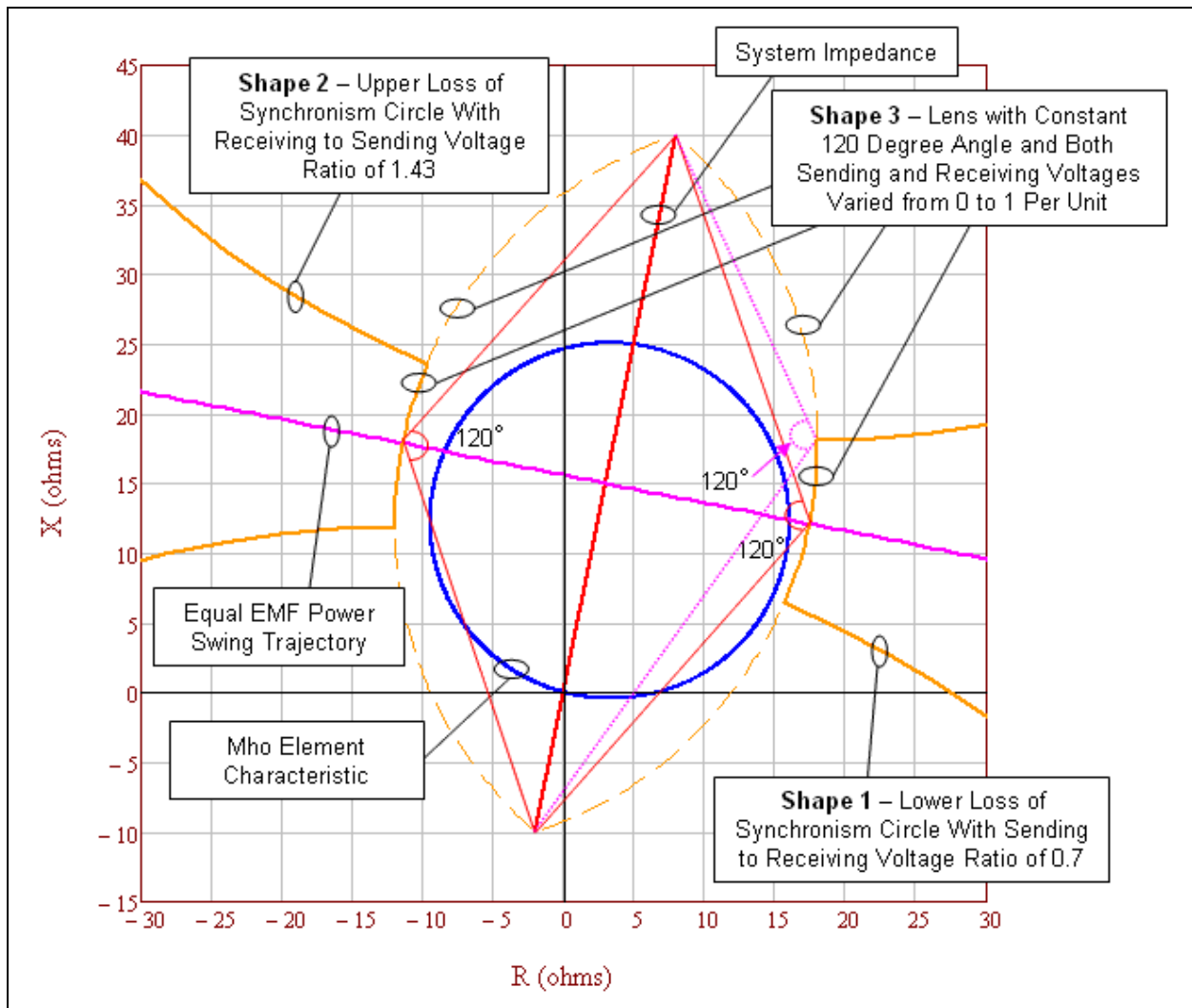
conditions. If the tripping portion of the impedance characteristics are completely contained within the unstable power swing region, the relay impedance element meets Criteria A in PRC-026-1 – Attachment B. A system separation angle of 120 degrees was chosen for the evaluation where PSB is not applied because it is generally accepted in the industry that recovery for a swing beyond this angle is unlikely to occur.<sup>14</sup>

The second bullet of PRC-026-1 – Attachment B, Criteria A, No. 1 evaluates impedance relay elements at a system separation angle of less than 120 degrees, similar to the first bullet described above. An angle less than 120 degrees may be used if a documented stability analysis demonstrates that the power swing becomes unstable at a system separation angle of less than 120 degrees.

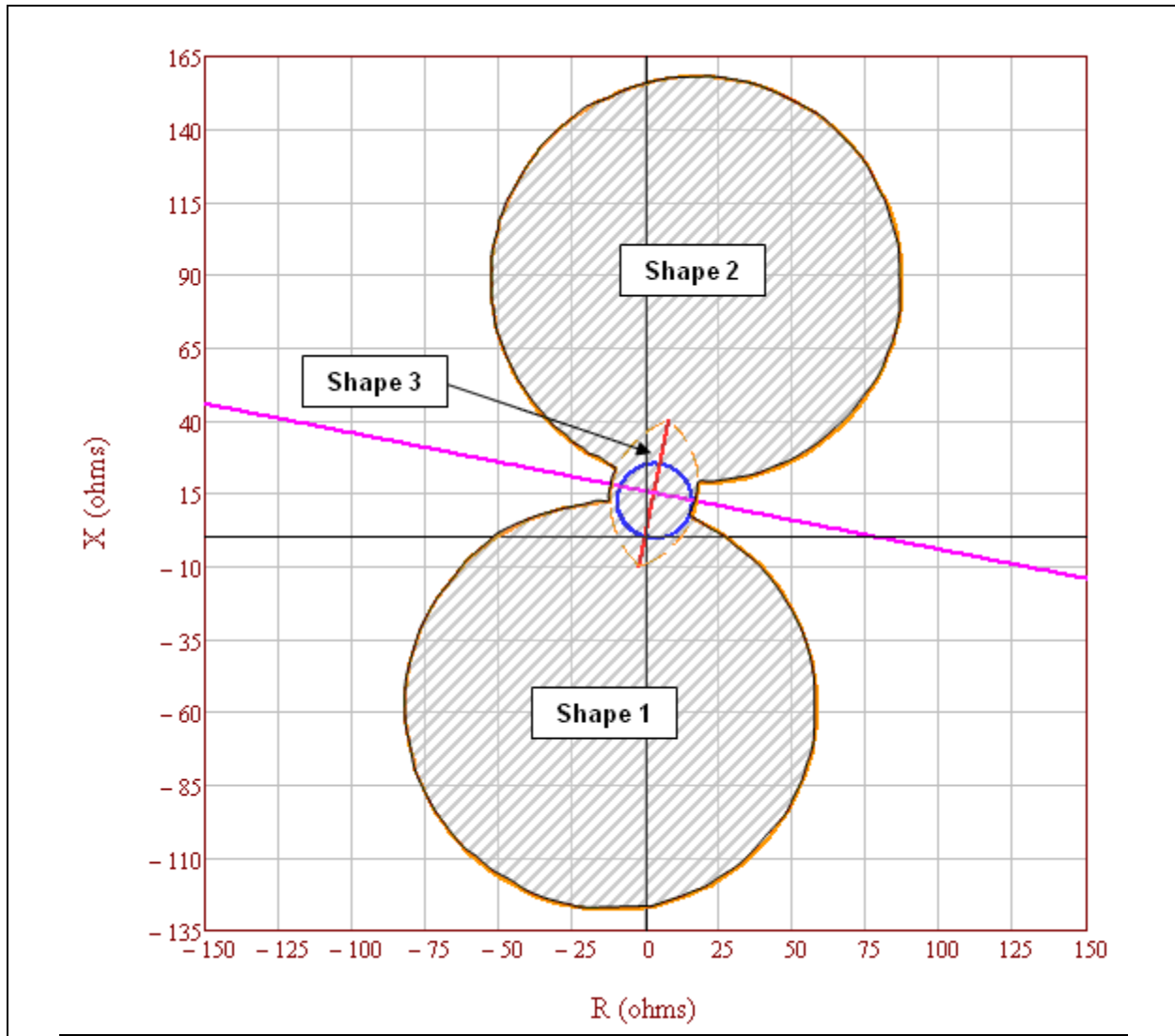
The exclusion of relay elements supervised by PSB in PRC-026-1 – Attachment A allows the Generator Owner or Transmission Owner to exclude protective relay elements if they are blocked from tripping by PSB relays. A PSB relay applied and set according to industry accepted practices prevent supervised load-responsive protective relays from tripping in response to power swings. Further, PSB relays are set to allow dependable tripping of supervised elements. The criteria in PRC-026-1 – Attachment B specifically applies to unsupervised elements that could trip for stable power swings. Therefore, load-responsive protective relay elements supervised by PSB can be excluded from the Requirements of this standard.

---

<sup>14</sup> “The critical angle for maintaining stability will vary depending on the contingency and the system condition at the time the contingency occurs; however, the likelihood of recovering from a swing that exceeds 120 degrees is marginal and 120 degrees is generally accepted as an appropriate basis for setting out-of-step protection. Given the importance of separating unstable systems, defining 120 degrees as the critical angle is appropriate to achieve a proper balance between dependable tripping for unstable power swings and secure operation for stable power swings.” NERC System Protection and Control Subcommittee, *Protection System Response to Power Swings*, August 2013: [http://www.nerc.com/comm/PC/System%20Protection%20and%20Control%20Subcommittee%20SPCS%2020/SPCS%20Power%20Swing%20Report\\_Final\\_20131015.pdf](http://www.nerc.com/comm/PC/System%20Protection%20and%20Control%20Subcommittee%20SPCS%2020/SPCS%20Power%20Swing%20Report_Final_20131015.pdf), p. 28.



**Figure 1.** An enlarged graphic illustrating the unstable power swing region formed by the union of three shapes in the impedance (R-X) plane: Shape 1) Lower loss of synchronism circle, Shape 2) Upper loss of synchronism circle, and Shape 3) Lens. The mho element characteristic is completely contained within the unstable power swing region (e.g., it does not intersect any portion of the unstable power swing region), therefore it complies with PRC-026-1 – Attachment B, Criteria A, No. 1.



**Figure 2.** Full graphic of unstable power swing region formed by the union of three shapes in the impedance (R-X) plane: Shape 1) Lower loss of synchronism circle, Shape 2) Upper loss of synchronism circle, and Shape 3) Lens. The mho element characteristic is completely contained within the unstable power swing region, therefore it meets PRC-26-1 – Attachment B, Criteria A, No.1.

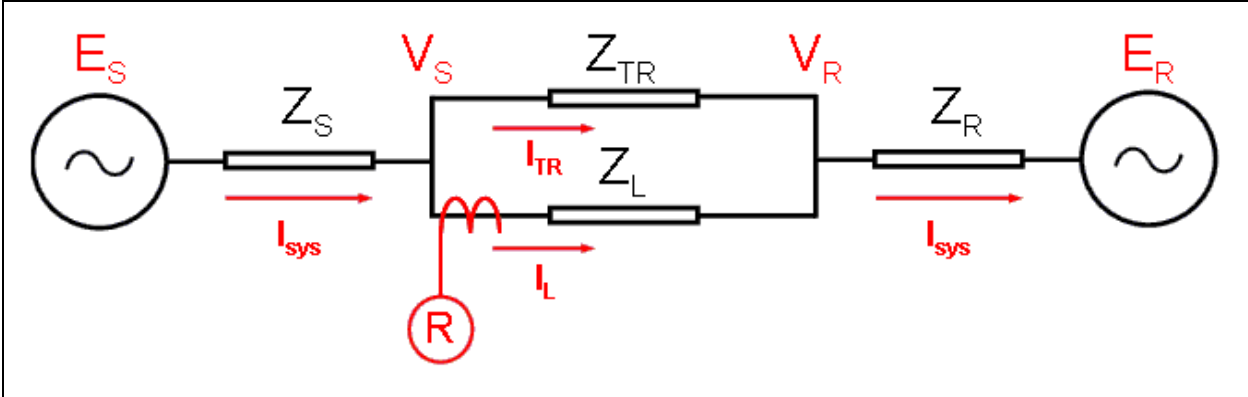
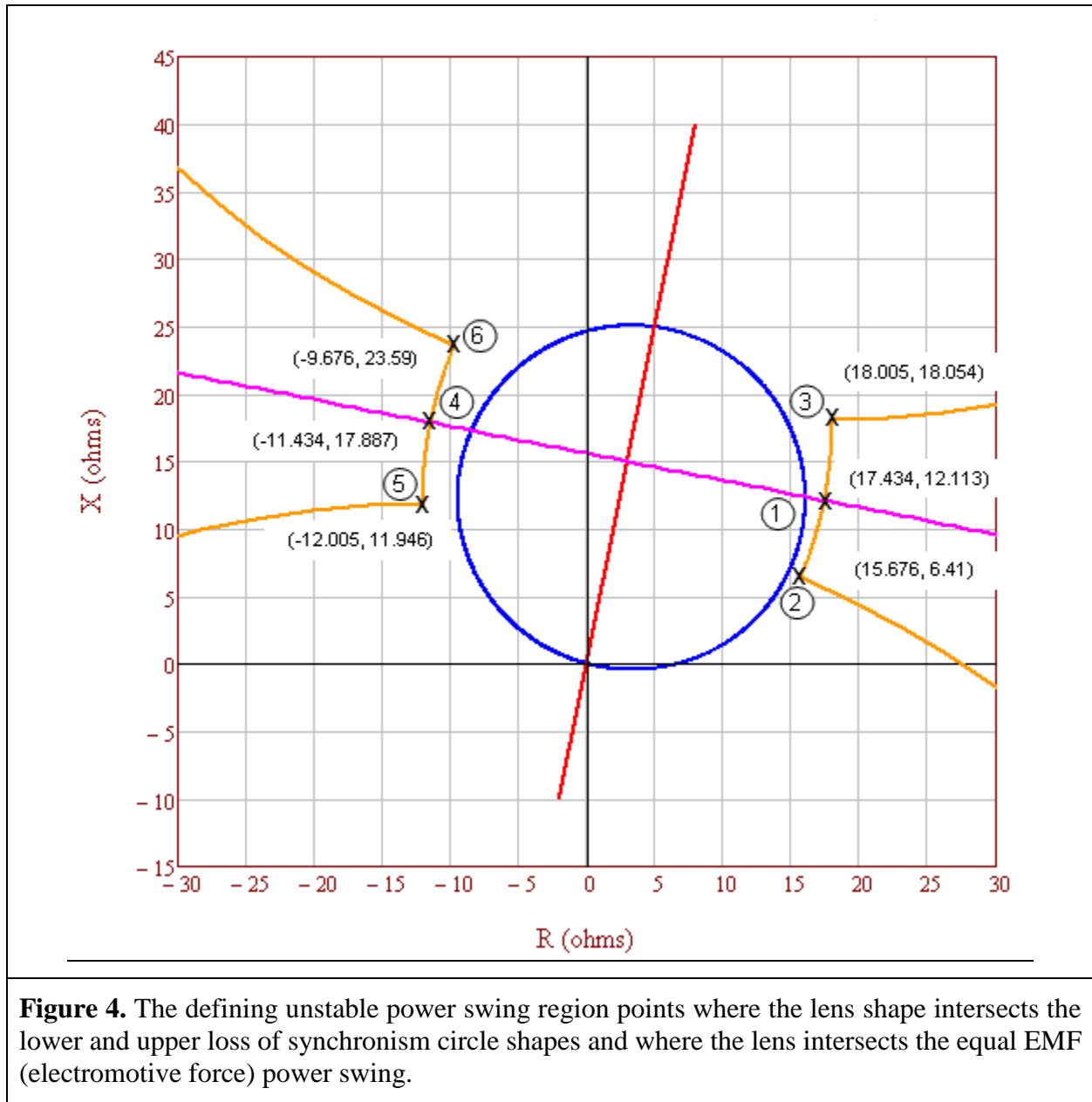


Figure 3. System impedance as seen by relay R.



Voltage (p.u.)	Left Side Coordinates		Right Side Coordinates	
	R	+ jX	R	+ jX
<b>0.7</b>	<b>-12.005</b>	<b>11.946</b>	<b>15.676</b>	<b>6.41</b>
0.72	-12.004	12.407	15.852	6.836
0.74	-11.996	12.857	16.018	7.255
0.76	-11.982	13.298	16.175	7.667
0.78	-11.961	13.729	16.321	8.073
0.8	-11.935	14.151	16.459	8.472
0.82	-11.903	14.563	16.589	8.865
0.84	-11.867	14.966	16.71	9.251
0.86	-11.826	15.361	16.824	9.631
0.88	-11.78	15.746	16.93	10.004
0.9	-11.731	16.123	17.03	10.371
0.92	-11.678	16.492	17.123	10.732
0.94	-11.621	16.852	17.209	11.086
0.96	-11.562	17.205	17.29	11.435
0.98	-11.499	17.55	17.364	11.777
<b>1</b>	<b>-11.434</b>	<b>17.887</b>	<b>17.434</b>	<b>12.113</b>
0.98	-11.364	18.223	17.499	12.45
0.96	-11.29	18.565	17.562	12.795
0.94	-11.209	18.914	17.621	13.148
0.92	-11.123	19.268	17.678	13.508
0.9	-11.03	19.629	17.731	13.877
0.88	-10.93	19.996	17.78	14.254
0.86	-10.824	20.369	17.826	14.639
0.84	-10.71	20.749	17.867	15.034
0.82	-10.589	21.135	17.903	15.437
0.8	-10.459	21.528	17.935	15.849
0.78	-10.321	21.927	17.961	16.271
0.76	-10.175	22.333	17.982	16.702
0.74	-10.018	22.745	17.996	17.143
0.72	-9.852	23.164	18.004	17.593
<b>0.7</b>	<b>-9.676</b>	<b>23.59</b>	<b>18.005</b>	<b>18.054</b>

**Figure 5.** Full table of 31 detailed lens shape point calculations. The bold highlighted rows correspond to the detailed calculations in Tables 2-7.

**Table 2. Example Calculation (Lens Point 1)**

This example is for calculating the impedance the first point of the lens characteristic. Equal source voltages are used for the 230 kV (base) line with the sending-end voltage ( $E_S$ ) leading the receiving-end voltage ( $E_R$ ) by 120 degrees. See Figures 3 and 4.

Eq. (6)	$E_S = \frac{V_{LL} \angle 120^\circ}{\sqrt{3}}$
	$E_S = \frac{230,000 \angle 120^\circ V}{\sqrt{3}}$

Table 2. Example Calculation (Lens Point 1)			
	$E_S = 132,791 \angle 120^\circ V$		
Eq. (7)	$E_R = \frac{V_{LL} \angle 0^\circ}{\sqrt{3}}$		
	$E_R = \frac{230,000 \angle 0^\circ V}{\sqrt{3}}$		
	$E_R = 132,791 \angle 0^\circ V$		
Given positive sequence impedance data (The transfer impedance $Z_{TR}$ is set to infinity).			
Given:	$Z_S = 2 + j10 \Omega$	$Z_L = 4 + j20 \Omega$	$Z_R = 4 + j20 \Omega$
Given:	$Z_{TR} = Z_L \times 10^{10} \Omega$		
Total impedance between generators.			
Eq. (8)	$Z_{total} = \frac{(Z_L \times Z_{TR})}{(Z_L + Z_{TR})}$		
	$Z_{total} = \frac{((4 + j20) \Omega \times (4 + j20)^{10} \Omega)}{((4 + j20) \Omega + (4 + j20)^{10} \Omega)}$		
	$Z_{total} = 4 + j20 \Omega$		
Total system impedance.			
Eq. (9)	$Z_{sys} = Z_S + Z_{total} + Z_R$		
	$Z_{sys} = (2 + j10) \Omega + (4 + j20) \Omega + (4 + j20) \Omega$		
	$Z_{sys} = 10 + j50 \Omega$		
Total system current from sending-end source.			
Eq. (10)	$I_{sys} = \frac{E_S - E_R}{Z_{sys}}$		
	$I_{sys} = \frac{132,791 \angle 120^\circ V - 132,791 \angle 0^\circ V}{(10 + j50) \Omega}$		
	$I_{sys} = 4,511 \angle 71.3^\circ A$		
The current as measured by the relay on $Z_L$ is only the current flowing through that line as determined by using the current divider equation.			
Eq. (11)	$I_L = I_{sys} \times \frac{Z_{TR}}{Z_L + Z_{TR}}$		
	$I_L = 4,511 \angle 71.3^\circ A \times \frac{(4 + j20)^{10} \Omega}{(4 + j20) \Omega + (4 + j20)^{10} \Omega}$		
	$I_L = 4,511 \angle 71.3^\circ A$		

Table 2. Example Calculation (Lens Point 1)	
The voltage as measured by the relay on $Z_L$ is the voltage drop from the sending-end source through the sending-end source impedance.	
Eq. (12)	$V_S = E_S - (Z_S \times I_{sys})$
	$V_S = 132,791 \angle 120^\circ V - [(2 + j10) \Omega \times 4,511 \angle 71.3^\circ A]$
	$V_S = 95,757 \angle 106.1^\circ V$
The impedance seen by the relay on $Z_L$ .	
Eq. (13)	$Z_{L-Relay} = \frac{V_S}{I_L}$
	$Z_{L-Relay} = \frac{95,757 \angle 106.1^\circ V}{4,511 \angle 71.3^\circ A}$
	$Z_{L-Relay} = 17.434 + j12.113 \Omega$

Table 3. Example Calculation (Lens Point 2)	
This example is for calculating the impedance second point of the lens characteristic. Unequal source voltages are used for the 230 kV (base) line with the sending-end voltage ( $E_S$ ) at 70% of the receiving-end voltage ( $E_R$ ) and leading the receiving-end voltage by 120 degrees. See Figures 3 and 4.	
Eq. (14)	$E_S = \frac{V_{LL} \angle 120^\circ}{\sqrt{3}} \times 70\%$
	$E_S = \frac{230,000 \angle 120^\circ V}{\sqrt{3}} \times 0.70$
	$E_S = 92,953.7 \angle 120^\circ V$
Eq. (15)	$E_R = \frac{V_{LL} \angle 0^\circ}{\sqrt{3}}$
	$E_R = \frac{230,000 \angle 0^\circ V}{\sqrt{3}}$
	$E_R = 132,791 \angle 0^\circ V$
Given positive sequence impedance data (The transfer impedance $Z_{TR}$ is set to infinity).	
Given:	$Z_S = 2 + j10 \Omega$ $Z_L = 4 + j20 \Omega$ $Z_R = 4 + j20 \Omega$
Given:	$Z_{TR} = Z_L \times 10^{10} \Omega$
Total impedance between generators.	
Eq. (16)	$Z_{total} = \frac{(Z_L \times Z_{TR})}{(Z_L + Z_{TR})}$



Table 3. Example Calculation (Lens Point 2)	
	$Z_{total} = \frac{((4 + j20) \Omega \times (4 + j20)^{10} \Omega)}{((4 + j20) \Omega + (4 + j20)^{10} \Omega)}$
	$Z_{total} = 4 + j20 \Omega$
Total system impedance.	
Eq. (17)	$Z_{sys} = Z_S + Z_{total} + Z_R$
	$Z_{sys} = (2 + j10) \Omega + (4 + j20) \Omega + (4 + j20) \Omega$
	$Z_{sys} = 10 + j50 \Omega$
Total system current from sending-end source.	
Eq. (18)	$I_{sys} = \frac{E_S - E_R}{Z_{sys}}$
	$I_{sys} = \frac{92,953.7 \angle 120^\circ V - 132,791 \angle 0^\circ V}{(10 + j50) \Omega}$
	$I_{sys} = 3,854 \angle 77^\circ A$
The current as measured by the relay on Z <sub>L</sub> is only the current flowing through that line as determined by using the current divider equation.	
Eq. (19)	$I_L = I_{sys} \times \frac{Z_{TR}}{Z_L + Z_{TR}}$
	$I_L = 3,854 \angle 77^\circ A \times \frac{(4 + j20)^{10} \Omega}{(4 + j20) \Omega + (4 + j20)^{10} \Omega}$
	$I_L = 3,854 \angle 77^\circ A$
The voltage as measured by the relay on Z <sub>L</sub> is the voltage drop from the sending-end source through the sending-end source impedance.	
Eq. (20)	$V_S = E_S - (Z_S \times I_{sys})$
	$V_S = 92,953 \angle 120^\circ V - [(2 + j10) \Omega \times 3,854 \angle 77^\circ A]$
	$V_S = 65,271 \angle 99^\circ V$
The impedance seen by the relay on Z <sub>L</sub> .	
Eq. (21)	$Z_{L-Relay} = \frac{V_S}{I_L}$
	$Z_{L-Relay} = \frac{65,271 \angle 99^\circ V}{3,854 \angle 77^\circ A}$
	$Z_{L-Relay} = 15.676 + j6.41 \Omega$

Table 4. Example Calculation (Lens Point 3)			
This example is for calculating the impedance third point of the lens characteristic. Unequal source voltages are used for the 230 kV (base) line with the receiving-end voltage ( $E_R$ ) at 70% of the sending-end voltage ( $E_S$ ) and the sending-end voltage leading the receiving-end voltage by 120 degrees. See Figures 3 and 4.			
Eq. (22)	$E_S = \frac{V_{LL} \angle 120^\circ}{\sqrt{3}}$		
	$E_S = \frac{230,000 \angle 120^\circ V}{\sqrt{3}}$		
	$E_S = 132,791 \angle 120^\circ V$		
Eq. (23)	$E_R = \frac{V_{LL} \angle 0^\circ}{\sqrt{3}} \times 70\%$		
	$E_R = \frac{230,000 \angle 0^\circ V}{\sqrt{3}} \times 0.70$		
	$E_R = 92,953.7 \angle 0^\circ V$		
Given positive sequence impedance data (The transfer impedance $Z_{TR}$ is set to infinity).			
Given:	$Z_S = 2 + j10 \Omega$	$Z_L = 4 + j20 \Omega$	$Z_R = 4 + j20 \Omega$
Given:	$Z_{TR} = Z_L \times 10^{10} \Omega$		
Total impedance between generators.			
Eq. (24)	$Z_{total} = \frac{(Z_L \times Z_{TR})}{(Z_L + Z_{TR})}$		
	$Z_{total} = \frac{((4 + j20) \Omega \times (4 + j20)^{10} \Omega)}{((4 + j20) \Omega + (4 + j20)^{10} \Omega)}$		
	$Z_{total} = 4 + j20 \Omega$		
Total system impedance.			
Eq. (25)	$Z_{sys} = Z_S + Z_{total} + Z_R$		
	$Z_{sys} = (2 + j10) \Omega + (4 + j20) \Omega + (4 + j20) \Omega$		
	$Z_{sys} = 10 + j50 \Omega$		
Total system current from sending-end source.			
Eq. (26)	$I_{sys} = \frac{E_S - E_R}{Z_{sys}}$		
	$I_{sys} = \frac{132,791 \angle 120^\circ V - 92,953.7 \angle 0^\circ V}{(10 + j50) \Omega}$		
	$I_{sys} = 3,854 \angle 65.5^\circ A$		

Table 4. Example Calculation (Lens Point 3)	
The current as measured by the relay on Z <sub>L</sub> is only the current flowing through that line as determined by using the current divider equation.	
Eq. (27)	$I_L = I_{sys} \times \frac{Z_{TR}}{Z_L + Z_{TR}}$
	$I_L = 3,854 \angle 65.5^\circ A \times \frac{(4 + j20)^{10} \Omega}{(4 + j20) \Omega + (4 + j20)^{10} \Omega}$
	$I_L = 3,854 \angle 65.5^\circ A$
The voltage as measured by the relay on Z <sub>L</sub> is the voltage drop from the sending-end source through the sending-end source impedance.	
Eq. (28)	$V_S = E_S - (Z_S \times I_L)$
	$V_S = 132,791 \angle 120^\circ V - [(2 + j10) \Omega \times 3,854 \angle 65.5^\circ A]$
	$V_S = 98,265 \angle 110.6^\circ V$
The impedance seen by the relay on Z <sub>L</sub> .	
Eq. (29)	$Z_{L-Relay} = \frac{V_S}{I_L}$
	$Z_{L-Relay} = \frac{98,265 \angle 110.6^\circ V}{3,854 \angle 65.5^\circ A}$
	$Z_{L-Relay} = 18.005 + j18.054 \Omega$

Table 5. Example Calculation (Lens Point 4)	
This example is for calculating the impedance fourth point of the lens characteristic. Equal source voltages are used for the 230 kV (base) line with the sending-end voltage (E <sub>S</sub> ) leading the receiving-end voltage (E <sub>R</sub> ) by 240 degrees. See Figures 3 and 4.	
Eq. (30)	$E_S = \frac{V_{LL} \angle 240^\circ}{\sqrt{3}}$
	$E_S = \frac{230,000 \angle 240^\circ V}{\sqrt{3}}$
	$E_S = 132,791 \angle 240^\circ V$
Eq. (31)	$E_R = \frac{V_{LL} \angle 0^\circ}{\sqrt{3}}$
	$E_R = \frac{230,000 \angle 0^\circ V}{\sqrt{3}}$
	$E_R = 132,791 \angle 0^\circ V$

Table 5. Example Calculation (Lens Point 4)			
Given positive sequence impedance data (The transfer impedance $Z_{TR}$ is set to infinity).			
Given:	$Z_S = 2 + j10 \Omega$	$Z_L = 4 + j20 \Omega$	$Z_R = 4 + j20 \Omega$
Given:	$Z_{TR} = Z_L \times 10^{10} \Omega$		
Total impedance between generators.			
Eq. (32)	$Z_{total} = \frac{(Z_L \times Z_{TR})}{(Z_L + Z_{TR})}$		
	$Z_{total} = \frac{((4 + j20) \Omega \times (4 + j20)^{10} \Omega)}{((4 + j20) \Omega + (4 + j20)^{10} \Omega)}$		
	$Z_{total} = 4 + j20 \Omega$		
Total system impedance.			
Eq. (33)	$Z_{sys} = Z_S + Z_{total} + Z_R$		
	$Z_{sys} = (2 + j10) \Omega + (4 + j20) \Omega + (4 + j20) \Omega$		
	$Z_{sys} = 10 + j50 \Omega$		
Total system current from sending-end source.			
Eq. (34)	$I_{sys} = \frac{E_S - E_R}{Z_{sys}}$		
	$I_{sys} = \frac{132,791 \angle 240^\circ V - 132,791 \angle 0^\circ V}{(10 + j50) \Omega}$		
	$I_{sys} = 4,510 \angle 131.3^\circ A$		
The current as measured by the relay on ZL is only the current flowing through that line as determined by using the current divider equation.			
Eq. (35)	$I_L = I_{sys} \times \frac{Z_{TR}}{Z_L + Z_{TR}}$		
	$I_L = 4,510 \angle 131.1^\circ A \times \frac{(4 + j20)^{10} \Omega}{(4 + j20) \Omega + (4 + j20)^{10} \Omega}$		
	$I_L = 4,510 \angle 131.1^\circ A$		
The voltage as measured by the relay on ZL is the voltage drop from the sending-end source through the sending-end source impedance.			
Eq. (36)	$V_S = E_S - (Z_S \times I_L)$		
	$V_S = 132,791 \angle 240^\circ V - [(2 + j10) \Omega \times 4,510 \angle 131.1^\circ A]$		
	$V_S = 95,756 \angle -106.1^\circ V$		

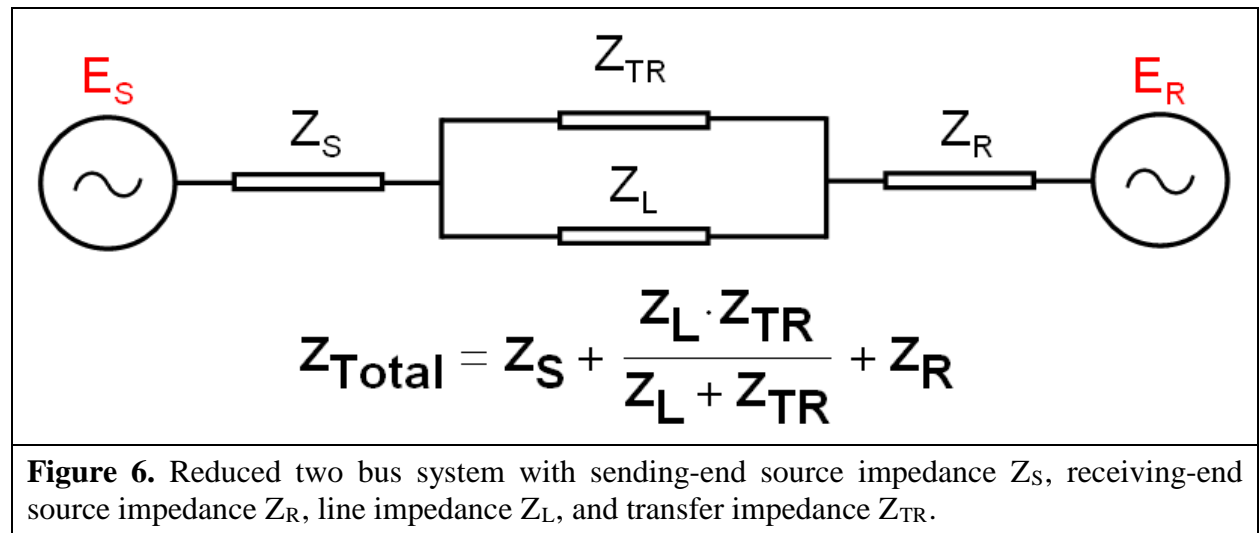
Table 5. Example Calculation (Lens Point 4)	
The impedance seen by the relay on $Z_L$ .	
Eq. (37)	$Z_{L-Relay} = \frac{V_S}{I_L}$
	$Z_{L-Relay} = \frac{95,756 \angle -106.1^\circ V}{4,510 \angle 131.1^\circ A}$
	$Z_{L-Relay} = -11.434 + j17.887 \Omega$

Table 6. Example Calculation (Lens Point 5)	
This example is for calculating the impedance fifth point of the lens characteristic. Unequal source voltages are used for the 230 kV (base) line with the sending-end voltage ( $E_S$ ) at 70% of the receiving-end voltage ( $E_R$ ) and leading the receiving-end voltage by 240 degrees. See Figures 3 and 4.	
Eq. (38)	$E_S = \frac{V_{LL} \angle 240^\circ}{\sqrt{3}} \times 70\%$
	$E_S = \frac{230,000 \angle 240^\circ V}{\sqrt{3}} \times 0.70$
	$E_S = 92,953.7 \angle 240^\circ V$
Eq. (39)	$E_R = \frac{V_{LL} \angle 0^\circ}{\sqrt{3}}$
	$E_R = \frac{230,000 \angle 0^\circ V}{\sqrt{3}}$
	$E_R = 132,791 \angle 0^\circ V$
Given positive sequence impedance data (The transfer impedance $Z_{TR}$ is set to infinity).	
Given:	$Z_S = 2 + j10 \Omega$ $Z_L = 4 + j20 \Omega$ $Z_R = 4 + j20 \Omega$
Given:	$Z_{TR} = Z_L \times 10^{10} \Omega$
Total impedance between generators.	
Eq. (40)	$Z_{total} = \frac{(Z_L \times Z_{TR})}{(Z_L + Z_{TR})}$
	$Z_{total} = \frac{((4 + j20) \Omega \times (4 + j20)^{10} \Omega)}{((4 + j20) \Omega + (4 + j20)^{10} \Omega)}$
	$Z_{total} = 4 + j20 \Omega$
Total system impedance.	
Eq. (41)	$Z_{sys} = Z_S + Z_{total} + Z_R$

Table 6. Example Calculation (Lens Point 5)	
	$Z_{sys} = (2 + j10 \Omega) + (4 + j20 \Omega) + (4 + j20 \Omega)$
	$Z_{sys} = 10 + j50 \Omega$
Total system current from sending-end source.	
Eq. (42)	$I_{sys} = \frac{E_S - E_R}{Z_{sys}}$
	$I_{sys} = \frac{92,953.7 \angle 240^\circ V - 132,791 \angle 0^\circ V}{10 + j50 \Omega}$
	$I_{sys} = 3,854 \angle 125.5^\circ A$
The current as measured by the relay on $Z_L$ is only the current flowing through that line as determined by using the current divider equation.	
Eq. (43)	$I_L = I_{sys} \times \frac{Z_{TR}}{Z_L + Z_{TR}}$
	$I_L = 3,854 \angle 125.5^\circ A \times \frac{(4 + j20)^{10} \Omega}{(4 + j20) \Omega + (4 + j20)^{10} \Omega}$
	$I_L = 3,854 \angle 125.5^\circ A$
The voltage as measured by the relay on $Z_L$ is the voltage drop from the sending-end source through the sending-end source impedance.	
Eq. (44)	$V_S = E_S - (Z_S \times I_L)$
	$V_S = 92,953.7 \angle 240^\circ V - [(2 + j10) \Omega \times 3,854 \angle 125.5^\circ A]$
	$V_S = 65,270.5 \angle -99.4^\circ V$
The impedance seen by the relay on $Z_L$ .	
Eq. (45)	$Z_{L-Relay} = \frac{V_S}{I_L}$
	$Z_{L-Relay} = \frac{65,270.5 \angle -99.4^\circ V}{3,854 \angle 125.5^\circ A}$
	$Z_{L-Relay} = -12.005 + j11.946 \Omega$

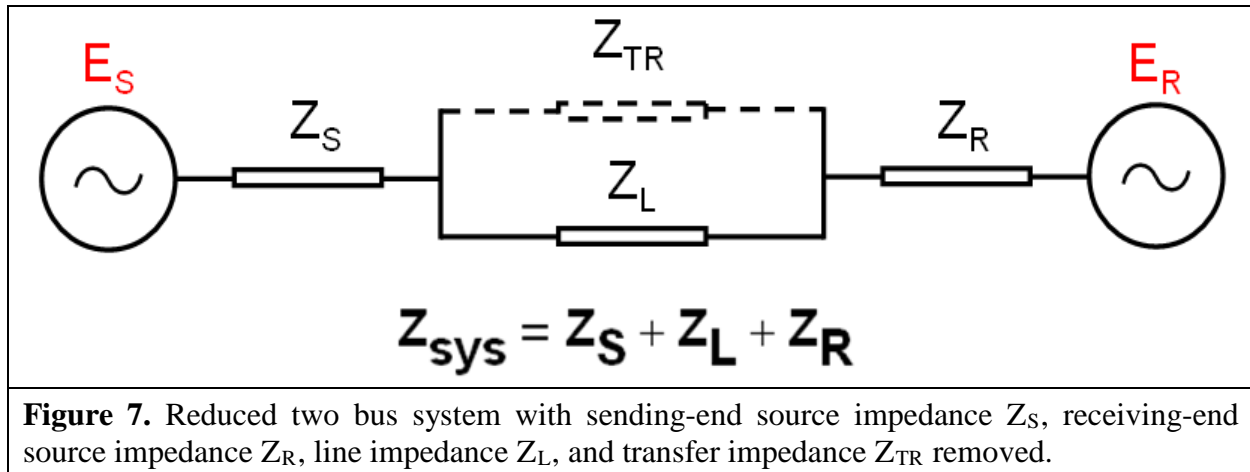
Table 7. Example Calculation (Lens Point 6)			
This example is for calculating the impedance sixth point of the lens characteristic. Unequal source voltages are used for the 230 kV (base) line with the receiving-end voltage ( $E_R$ ) at 70% of the sending-end voltage ( $E_S$ ) and the sending-end voltage leading the receiving-end voltage by 240 degrees. See Figures 3 and 4.			
Eq. (46)	$E_S = \frac{V_{LL} \angle 240^\circ}{\sqrt{3}}$		
	$E_S = \frac{230,000 \angle 240^\circ V}{\sqrt{3}}$		
	$E_S = 132,791 \angle 240^\circ V$		
Eq. (47)	$E_R = \frac{V_{LL} \angle 0^\circ}{\sqrt{3}} \times 70\%$		
	$E_R = \frac{230,000 \angle 0^\circ V}{\sqrt{3}} \times 0.70$		
	$E_R = 92,953.7 \angle 0^\circ V$		
Given positive sequence impedance data (The transfer impedance $Z_{TR}$ is set to infinity).			
Given:	$Z_S = 2 + j10 \Omega$	$Z_L = 4 + j20 \Omega$	$Z_R = 4 + j20 \Omega$
Given:	$Z_{TR} = Z_L \times 10^{10} \Omega$		
Total impedance between generators.			
Eq. (48)	$Z_{total} = \frac{(Z_L \times Z_{TR})}{(Z_L + Z_{TR})}$		
	$Z_{total} = \frac{(4 + j20) \Omega \times (4 + j20)^{10} \Omega}{(4 + j20) \Omega + (4 + j20)^{10} \Omega}$		
	$Z_{total} = 4 + j20 \Omega$		
Total system impedance.			
Eq. (49)	$Z_{sys} = Z_S + Z_{total} + Z_R$		
	$Z_{sys} = (2 + j10) \Omega + (4 + j20) \Omega + (4 + j20) \Omega$		
	$Z_{sys} = 10 + j50 \Omega$		
Total system current from sending-end source.			
Eq. (50)	$I_{sys} = \frac{E_S - E_R}{Z_{sys}}$		
	$I_{sys} = \frac{132,791 \angle 240^\circ V - 92,953.7 \angle 0^\circ V}{10 + j50 \Omega}$		
	$I_{sys} = 3,854 \angle 137.1^\circ A$		

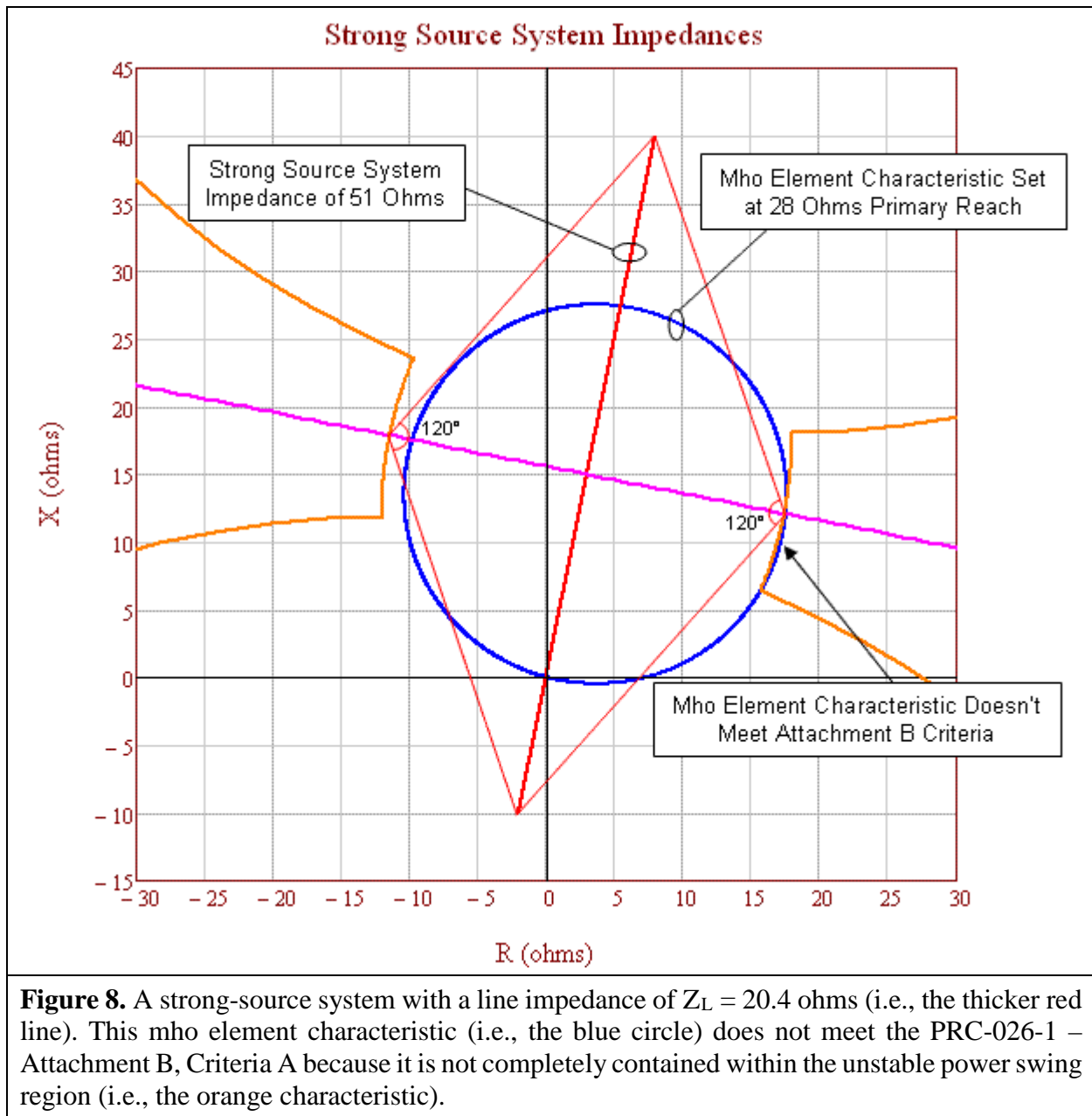
Table 7. Example Calculation (Lens Point 6)	
The current as measured by the relay on $Z_L$ is only the current flowing through that line as determined by using the current divider equation.	
Eq. (51)	$I_L = I_{sys} \times \frac{Z_{TR}}{Z_L + Z_{TR}}$
	$I_L = 3,854 \angle 137.1^\circ A \times \frac{(4 + j20)^{10} \Omega}{(4 + j20) \Omega + (4 + j20)^{10} \Omega}$
	$I_L = 3,854 \angle 137.1^\circ A$
The voltage as measured by the relay on $Z_L$ is the voltage drop from the sending-end source through the sending-end source impedance.	
Eq. (52)	$V_S = E_S - (Z_S \times I_L)$
	$V_S = 132,791 \angle 240^\circ V - [(2 + j10) \Omega \times 3,854 \angle 137.1^\circ A]$
	$V_S = 98,265 \angle -110.6^\circ V$
The impedance seen by the relay on $Z_L$ .	
Eq. (53)	$Z_{L-Relay} = \frac{V_S}{I_L}$
	$Z_{L-Relay} = \frac{98,265 \angle -110.6^\circ V}{3,854 \angle 137.1^\circ A}$
	$Z_{L-Relay} = -9.676 + j23.59 \Omega$



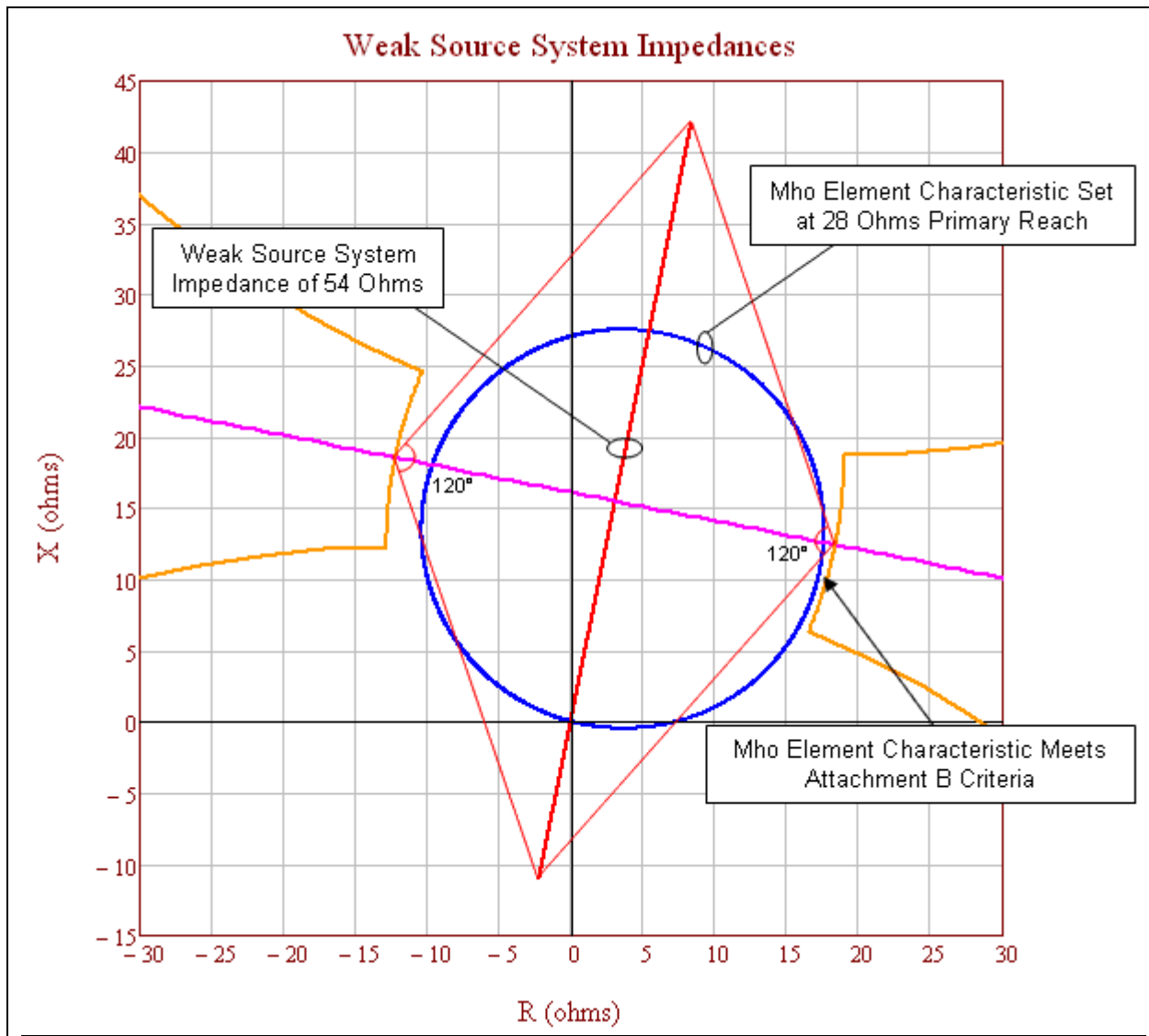
**Figure 6.** Reduced two bus system with sending-end source impedance  $Z_S$ , receiving-end source impedance  $Z_R$ , line impedance  $Z_L$ , and transfer impedance  $Z_{TR}$ .





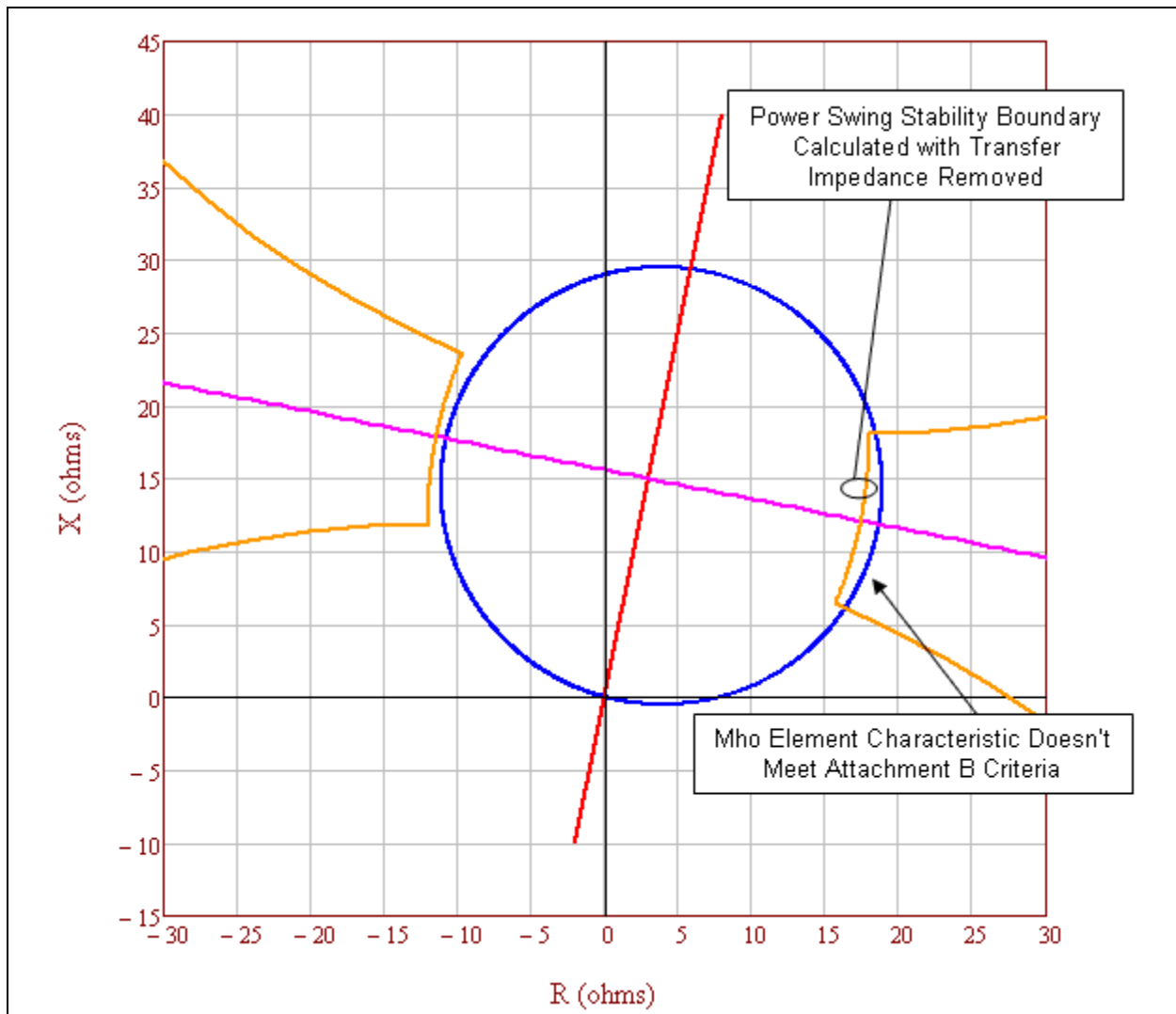


The figure above represents a heavy-loaded system using a maximum generation profile. The mho element characteristic (set at 137% of  $Z_L$ ) extends into the unstable power swing region (i.e., the orange characteristic). Using the strongest source system is more conservative because it shrinks the unstable power swing region, bringing it closer to the mho element characteristic. This figure also graphically represents the effect of a system strengthening over time and this is the reason for re-evaluation if the relay has not been evaluated in the last five calendar years. Figure 9 below depicts a relay that meets the PRC-026-1 – Attachment B, Criteria A. Figure 8 depicts the same relay with the same setting five years later, where each source has strengthened by about 10% and now the same mho element characteristic does not meet Criteria A.



**Figure 9.** A weak-source system with a line impedance of  $Z_L = 20.4$  ohms (i.e., the thicker red line). This mho element characteristic (i.e., the blue circle) meets the PRC-026-1 – Attachment B, Criteria A because it is completely contained within the unstable power swing region (i.e., the orange characteristic).

The figure above represents a lightly loaded system, using a minimum generation profile. The mho element characteristic (set at 137% of  $Z_L$ ) does not extend into the unstable power swing region (i.e., the orange characteristic). Using a weaker source system expands the unstable power swing region away from the mho element characteristic.



**Figure 10.** This is an example of an unstable power swing region (i.e., the orange characteristic) with the transfer impedance removed. This relay mho element characteristic (i.e., the blue circle) does not meet PRC-026-1 – Attachment B, Criteria A because it is not completely contained within the unstable power swing region.

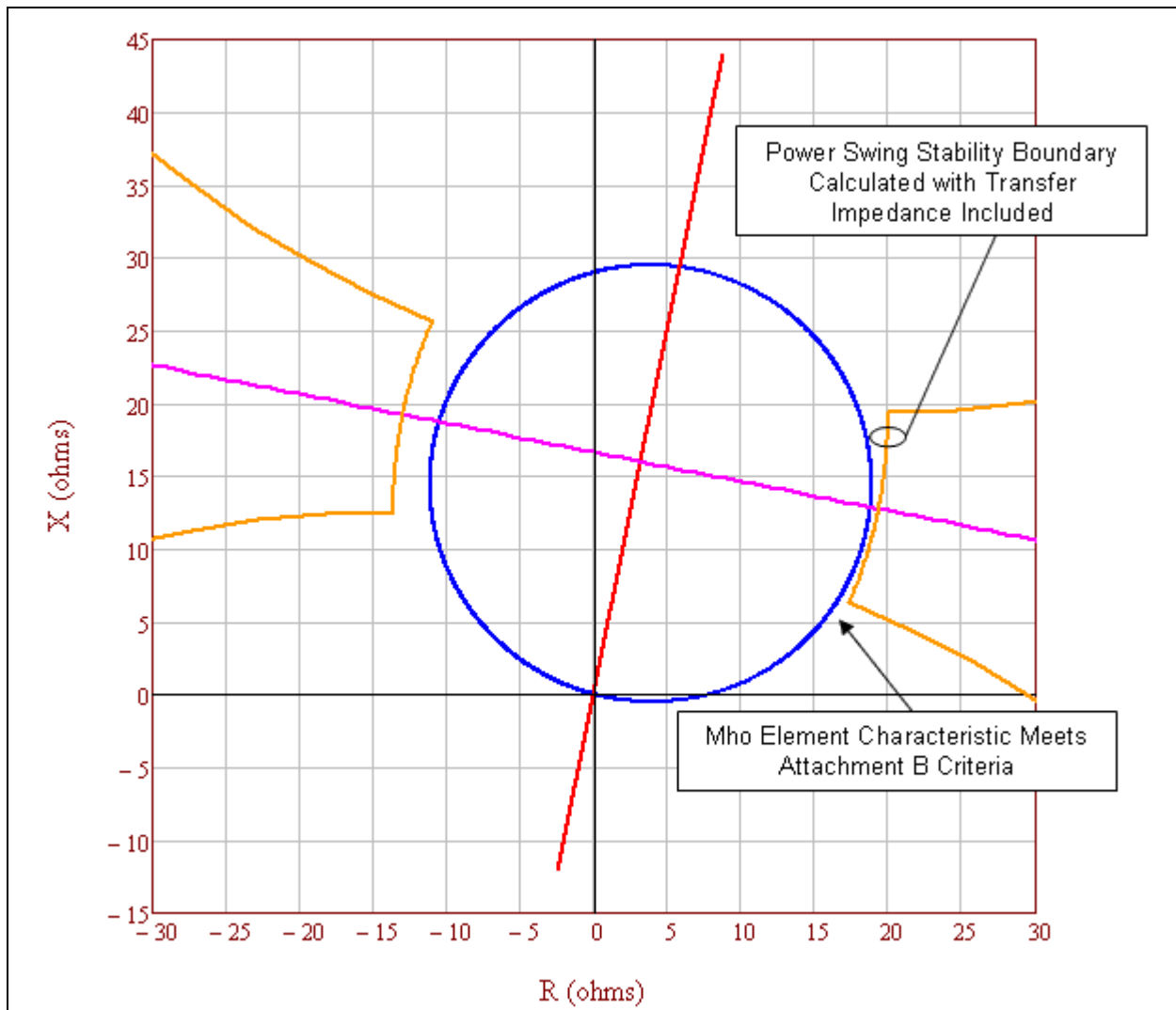
**Table 8. Example Calculation (Transfer Impedance Removed)**

Calculations for the point at 120 degrees with equal source impedances. The total system current equals the line current. See Figure 10.

Eq. (54)	$E_S = \frac{V_{LL} \angle 120^\circ}{\sqrt{3}}$
	$E_S = \frac{230,000 \angle 120^\circ V}{\sqrt{3}}$
	$E_S = 132,791 \angle 120^\circ V$

Table 8. Example Calculation (Transfer Impedance Removed)			
Eq. (55)	$E_R = \frac{V_{LL} \angle 0^\circ}{\sqrt{3}}$		
	$E_R = \frac{230,000 \angle 0^\circ V}{\sqrt{3}}$		
	$E_R = 132,791 \angle 0^\circ V$		
Given impedance data.			
Given:	$Z_S = 2 + j10 \Omega$	$Z_L = 4 + j20 \Omega$	$Z_R = 4 + j20 \Omega$
Given:	$Z_{TR} = Z_L \times 10^{10} \Omega$		
Total impedance between generators.			
Eq. (56)	$Z_{total} = \frac{(Z_L \times Z_{TR})}{(Z_L + Z_{TR})}$		
	$Z_{total} = \frac{(4 + j20) \Omega \times (4 + j20)^{10} \Omega}{(4 + j20) \Omega + (4 + j20)^{10} \Omega}$		
	$Z_{total} = 4 + j20 \Omega$		
Total system impedance.			
Eq. (57)	$Z_{sys} = Z_S + Z_{total} + Z_R$		
	$Z_{sys} = (2 + j10) \Omega + (4 + j20) \Omega + (4 + j20) \Omega$		
	$Z_{sys} = 10 + j50 \Omega$		
Total system current from sending-end source.			
Eq. (58)	$I_{sys} = \frac{E_S - E_R}{Z_{sys}}$		
	$I_{sys} = \frac{132,791 \angle 120^\circ V - 132,791 \angle 0^\circ V}{10 + j50 \Omega}$		
	$I_{sys} = 4,511 \angle 71.3^\circ A$		
The current as measured by the relay on $Z_L$ is only the current flowing through that line as determined by using the current divider equation.			
Eq. (59)	$I_L = I_{sys} \times \frac{Z_{TR}}{Z_L + Z_{TR}}$		
	$I_L = 4,511 \angle 71.3^\circ A \times \frac{(4 + j20)^{10} \Omega}{(4 + j20) \Omega + (4 + j20)^{10} \Omega}$		
	$I_L = 4,511 \angle 71.3^\circ A$		

Table 8. Example Calculation (Transfer Impedance Removed)	
The voltage as measured by the relay on $Z_L$ is the voltage drop from the sending-end source through the sending-end source impedance.	
Eq. (60)	$V_S = E_S - (Z_S \times I_{sys})$
	$V_S = 132,791 \angle 120^\circ V - [(2 + j10 \Omega) \times 4,511 \angle 71.3^\circ A]$
	$V_S = 95,757 \angle 106.1^\circ V$
The impedance seen by the relay on $Z_L$ .	
Eq. (61)	$Z_{L-Relay} = \frac{V_S}{I_L}$
	$Z_{L-Relay} = \frac{95,757 \angle 106.1^\circ V}{4,511 \angle 71.3^\circ A}$
	$Z_{L-Relay} = 17.434 + j12.113 \Omega$



**Figure 11.** This is an example of an unstable power swing region (i.e., the orange characteristic) with the transfer impedance included. The mho element characteristic (i.e., the blue circle) meets the PRC-026-1 – Attachment B, Criteria A because it is completely contained within the unstable power swing region. However, including the transfer impedance in the calculation is not compliant with PRC-026-1 – Attachment B Criteria A.

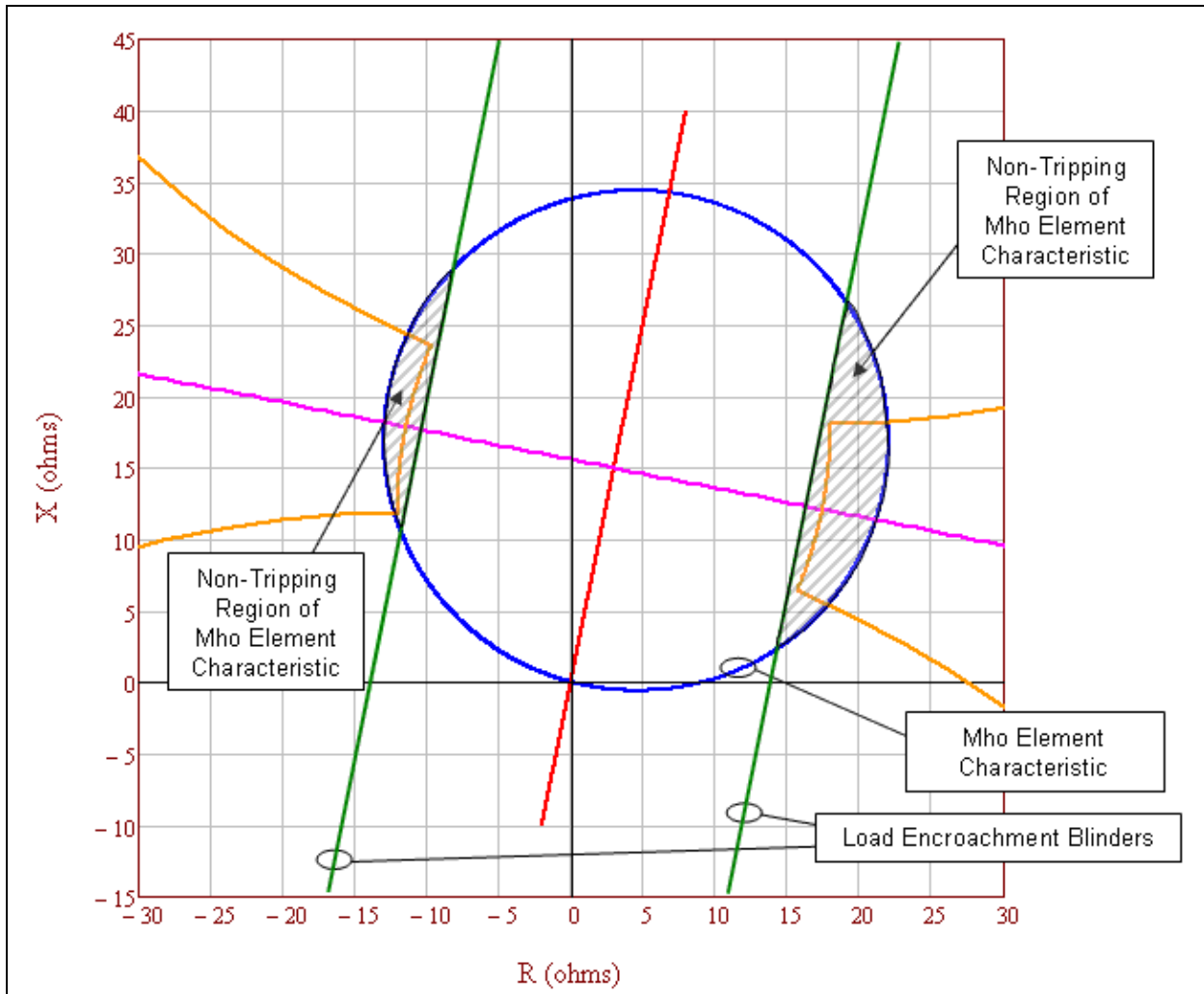
In the figure above, the transfer impedance is 5 times the line impedance. The unstable power swing region has expanded out beyond the mho element characteristic due to the infeed effect from the parallel current through the transfer impedance, thus allowing the mho element characteristic to meet PRC-026-1 – Attachment B, Criteria A. However, including the transfer impedance in the calculation is not compliant with PRC-026-1 – Attachment B Criteria A.

Table 9. Example Calculation (Transfer Impedance Included)			
Calculations for the point at 120 degrees with equal source impedances. The total system current does not equal the line current. See Figure 11.			
Eq. (62)	$E_S = \frac{V_{LL} \angle 120^\circ}{\sqrt{3}}$		
	$E_S = \frac{230,000 \angle 120^\circ V}{\sqrt{3}}$		
	$E_S = 132,791 \angle 120^\circ V$		
Eq. (63)	$E_R = \frac{V_{LL} \angle 0^\circ}{\sqrt{3}}$		
	$E_R = \frac{230,000 \angle 0^\circ V}{\sqrt{3}}$		
	$E_R = 132,791 \angle 0^\circ V$		
Given impedance data.			
Given:	$Z_S = 2 + j10 \Omega$	$Z_L = 4 + j20 \Omega$	$Z_R = 4 + j20 \Omega$
Given:	$Z_{TR} = Z_L \times 5$		
	$Z_{TR} = (4 + j20) \Omega \times 5$		
	$Z_{TR} = 20 + j100 \Omega$		
Total impedance between generators.			
Eq. (64)	$Z_{total} = \frac{(Z_L \times Z_{TR})}{(Z_L + Z_{TR})}$		
	$Z_{total} = \frac{(4 + j20) \Omega \times (20 + j100) \Omega}{(4 + j20) \Omega + (20 + j100) \Omega}$		
	$Z_{total} = 3.333 + j16.667 \Omega$		
Total system impedance.			
Eq. (65)	$Z_{sys} = Z_S + Z_{total} + Z_R$		
	$Z_{sys} = (2 + j10) \Omega + (3.333 + j16.667) \Omega + (4 + j20) \Omega$		
	$Z_{sys} = 9.333 + j46.667 \Omega$		
Total system current from sending-end source.			
Eq. (66)	$I_{sys} = \frac{E_S - E_R}{Z_{sys}}$		
	$I_{sys} = \frac{132,791 \angle 120^\circ V - 132,791 \angle 0^\circ V}{9.333 + j46.667 \Omega}$		

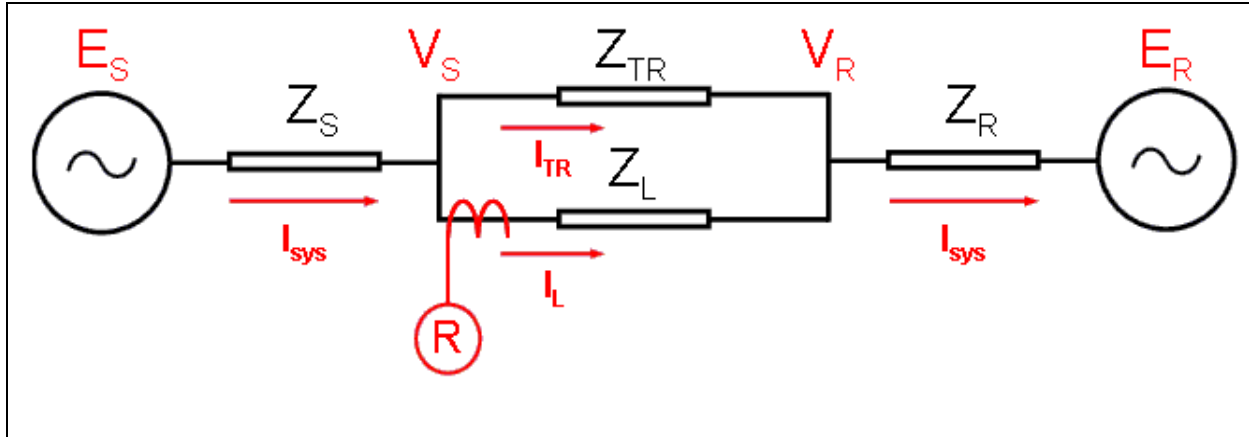


Table 9. Example Calculation (Transfer Impedance Included)	
	$I_{sys} = 4,832 \angle 71.3^\circ A$
The current as measured by the relay on $Z_L$ is only the current flowing through that line as determined by using the current divider equation.	
Eq. (67)	$I_L = I_{sys} \times \frac{Z_{TR}}{Z_L + Z_{TR}}$
	$I_L = 4,832 \angle 71.3^\circ A \times \frac{(20 + j100) \Omega}{(9.333 + j46.667) \Omega + (20 + j100) \Omega}$
	$I_L = 4,027.4 \angle 71.3^\circ A$
The voltage as measured by the relay on $Z_L$ is the voltage drop from the sending-end source through the sending-end source impedance.	
Eq. (68)	$V_S = E_S - (Z_S \times I_{sys})$
	$V_S = 132,791 \angle 120^\circ V - [(2 + j10 \Omega) \times 4,027 \angle 71.3^\circ A]$
	$V_S = 93,417 \angle 104.7^\circ V$
The impedance seen by the relay on $Z_L$ .	
Eq. (69)	$Z_{L-Relay} = \frac{V_S}{I_L}$
	$Z_{L-Relay} = \frac{93,417 \angle 104.7^\circ V}{4,027 \angle 71.3^\circ A}$
	$Z_{L-Relay} = 19.366 + j12.767 \Omega$

<b>Table 10. Percent Increase of a Lens Due To Parallel Transfer Impedance.</b>	
The following demonstrates the percent size increase of the lens characteristic for $Z_{TR}$ in multiples of $Z_L$ with the transfer impedance included.	
$Z_{TR}$ in multiples of $Z_L$	Percent increase of lens with equal EMF sources (Infinite source as reference)
Infinite	N/A
1000	0.05%
100	0.46%
10	4.63%
5	9.27%
2	23.26%
1	46.76%
0.5	94.14%
0.25	189.56%



**Figure 12.** The tripping portion not blocked by load encroachment (i.e., the parallel green lines) of the mho element characteristic (i.e., the blue circle) is completely contained within the unstable power swing region (i.e., the orange characteristic). Therefore, the mho element characteristic meets the PRC-026-1 – Attachment B, Criteria A.



**Figure 13:** The infeed diagram shows the impedance in front of the relay R with the parallel transfer impedance included. As the parallel transfer impedance approaches infinity, the impedances seen by the relay R in the forward direction becomes  $Z_L + Z_R$ .

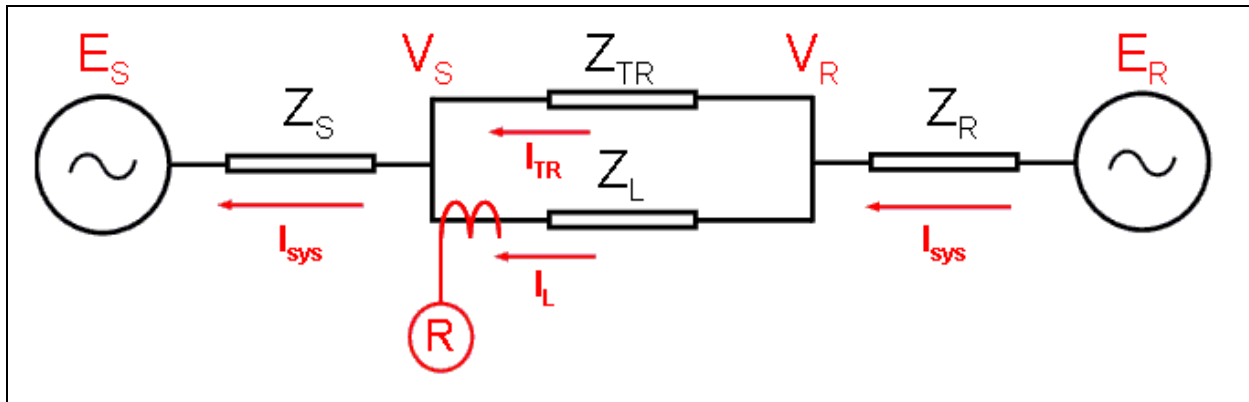
**Table 11. Calculations (System Apparent Impedance in the forward direction)**

The following equations are provided for calculating the apparent impedance back to the  $E_R$  source voltage as seen by relay R. Infeed equations from  $V_S$  to source  $E_R$  where  $E_R = 0$ . See Figure 13.

Eq. (70)	$I_L = \frac{V_S - V_R}{Z_L}$			
Eq. (71)	$I_{sys} = \frac{V_R - E_R}{Z_R}$			
Eq. (72)	$I_{sys} = I_L + I_{TR}$			
Eq. (73)	$I_{sys} = \frac{V_R}{Z_R}$	Since $E_R = 0$	Rearranged:	$V_R = I_{sys} \times Z_R$
Eq. (74)	$I_L = \frac{V_S - I_{sys} \times Z_R}{Z_L}$			
Eq. (75)	$I_L = \frac{V_S - [(I_L + I_{TR}) \times Z_R]}{Z_L}$			
Eq. (76)	$V_S = (I_L \times Z_L) + (I_L \times Z_R) + (I_{TR} \times Z_R)$			
Eq. (77)	$Z_{Relay} = \frac{V_S}{I_L} = Z_L + Z_R + \frac{I_{TR} \times Z_R}{I_L} = Z_L + Z_R \times \left(1 + \frac{I_{TR}}{I_L}\right)$			
Eq. (78)	$I_{TR} = I_{sys} \times \frac{Z_L}{Z_L + Z_{TR}}$			
Eq. (79)	$I_L = I_{sys} \times \frac{Z_{TR}}{Z_L + Z_{TR}}$			

**Table 11. Calculations (System Apparent Impedance in the forward direction)**

Eq. (80)	$\frac{I_{TR}}{I_L} = \frac{Z_L}{Z_{TR}}$
The infeed equations shows the impedance in front of the relay R with the parallel transfer impedance included. As the parallel transfer impedance approaches infinity, the impedances seen by the relay R in the forward direction becomes $Z_L + Z_R$ .	
Eq. (81)	$Z_{Relay} = Z_L + Z_R \times \left(1 + \frac{Z_L}{Z_{TR}}\right)$

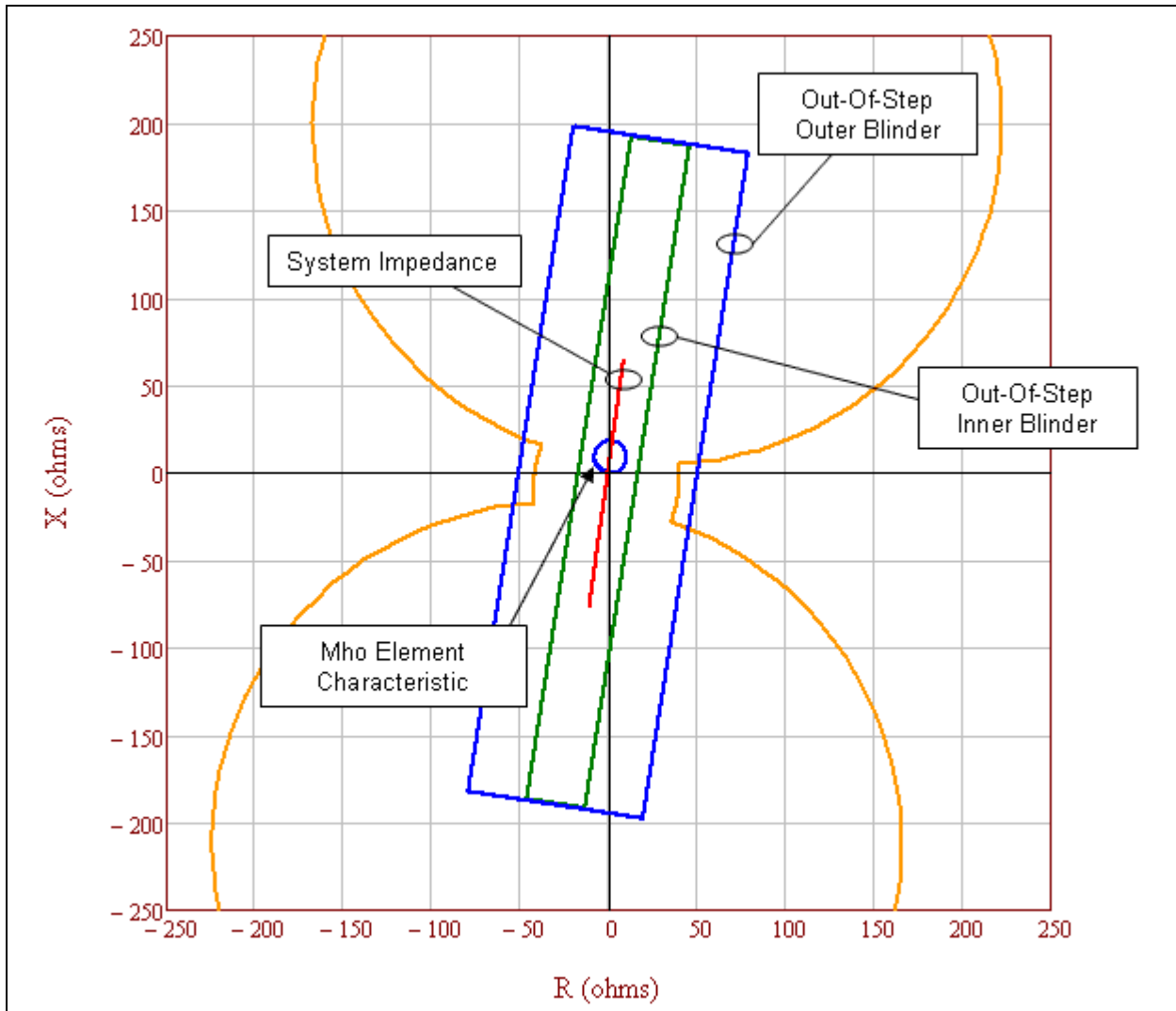


**Figure 14:** The infeed diagram shows the impedance behind relay R with the parallel transfer impedance included. As the parallel transfer impedance approaches infinity, the impedances seen by the relay R in the reverse direction becomes  $Z_S$ .

**Table 12. Calculations (System Apparent Impedance in the reverse direction)**

The following equations are provided for calculating the apparent impedance back to the $E_S$ source voltage as seen by relay R. Infeed equations from $V_R$ back to source $E_S$ where $E_S = 0$ . See Figure 14.				
Eq. (82)	$I_L = \frac{V_R - V_S}{Z_L}$			
Eq. (83)	$I_{sys} = \frac{V_S - E_S}{Z_S}$			
Eq. (84)	$I_{sys} = I_L + I_{TR}$			
Eq. (85)	$I_{sys} = \frac{V_S}{Z_S}$	Since $E_S = 0$	Rearranged:	$V_S = I_{sys} \times Z_S$
Eq. (86)	$I_L = \frac{V_R - I_{sys} \times Z_S}{Z_L}$			
Eq. (87)	$I_L = \frac{V_R - [(I_L + I_{TR}) \times Z_S]}{Z_L}$			

Table 12. Calculations (System Apparent Impedance in the reverse direction)		
Eq. (88)	$V_R = (I_L \times Z_L) + (I_L \times Z_S) + (I_{TR} \times Z_{RS})$	
Eq. (89)	$Z_{Relay} = \frac{V_R}{I_L} = Z_L + Z_S + \frac{I_{TR} \times Z_S}{I_L} = Z_L + Z_S \times \left(1 + \frac{I_{TR}}{I_L}\right)$	
Eq. (90)	$I_{TR} = I_{sys} \times \frac{Z_L}{Z_L + Z_{TR}}$	
Eq. (91)	$I_L = I_{sys} \times \frac{Z_{TR}}{Z_L + Z_{TR}}$	
Eq. (92)	$\frac{I_{TR}}{I_L} = \frac{Z_L}{Z_{TR}}$	
The infeed equations shows the impedance behind relay R with the parallel transfer impedance included. As the parallel transfer impedance approaches infinity, the impedances seen by the relay R in the reverse direction becomes $Z_S$ .		
Eq. (93)	$Z_{Relay} = Z_L + Z_S \times \left(1 + \frac{Z_L}{Z_{TR}}\right)$	As seen by relay R at the receiving-end of the line.
Eq. (94)	$Z_{Relay} = Z_S \times \left(1 + \frac{Z_L}{Z_{TR}}\right)$	Subtract $Z_L$ for relay R impedance as seen at sending-end of the line.



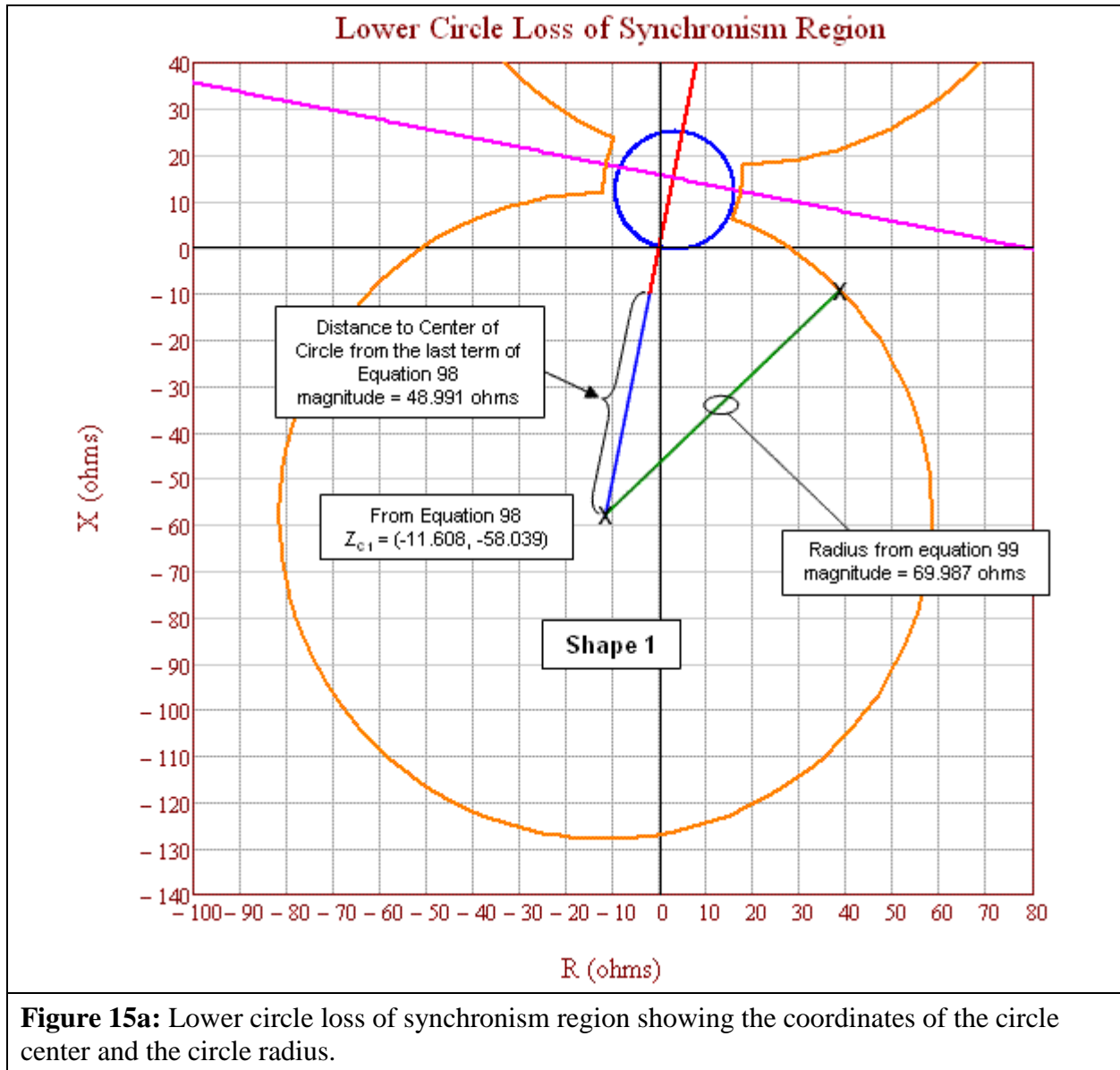
**Figure 15.** Out-of-step trip (OST) inner blinder (i.e., the parallel green lines) meets the PRC-026-1 – Attachment B, Criteria A because the inner OST blinder initiates tripping either On-The-Way-In or On-The-Way-Out. Since the inner blinder is completely contained within the unstable power swing region (i.e., the orange characteristic), it meets the PRC-026-1 – Attachment B, Criteria A.

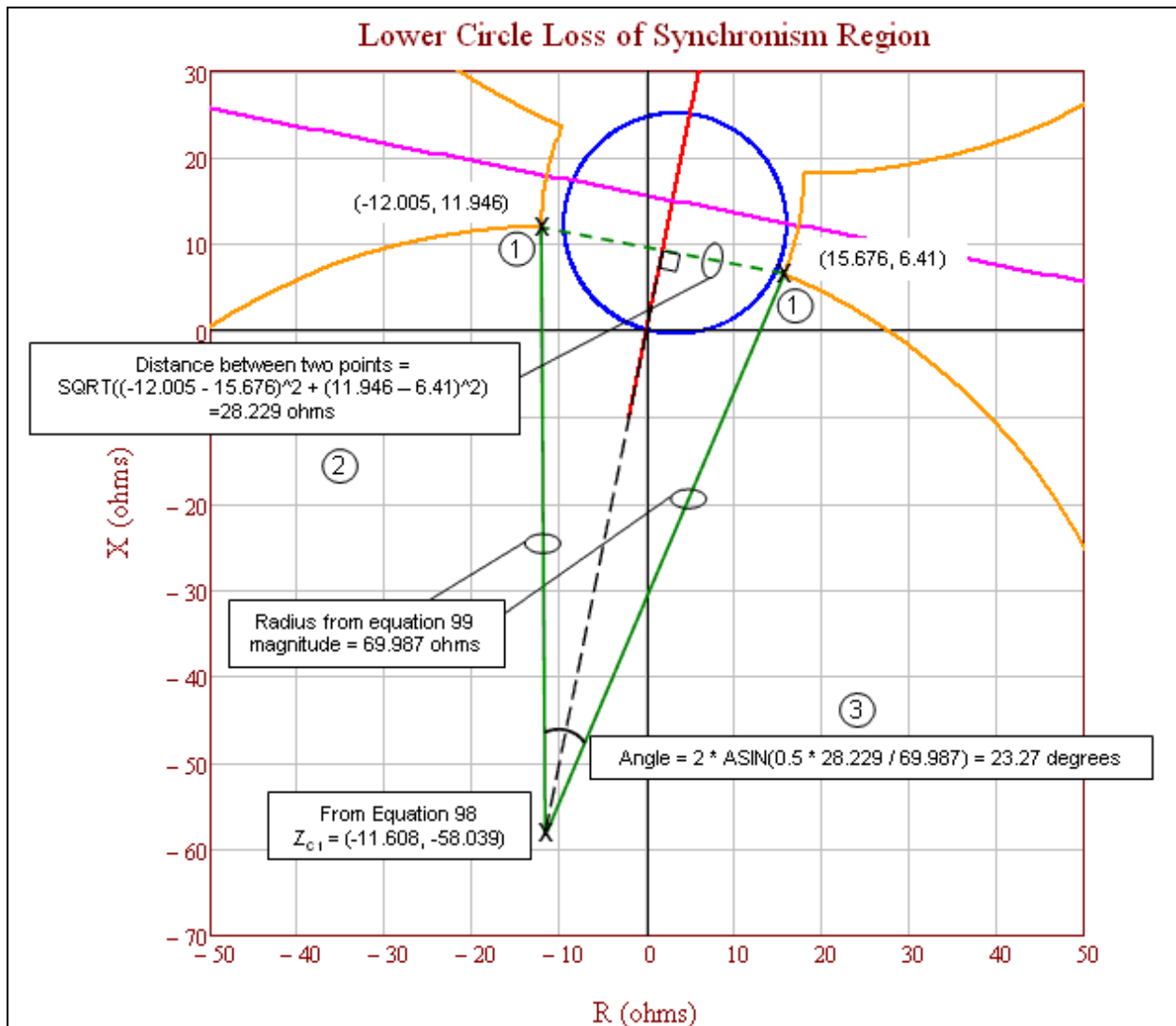
Table 13. Example Calculation (Voltage Ratios)		
These calculations are based on the loss of synchronism characteristics for the cases of $N < 1$ and $N > 1$ as found in the <i>Application of Out-of-Step Blocking and Tripping Relays</i> , GER-3180, p. 12, Figure 1. <sup>15</sup> The GE illustration shows the formulae used to calculate the radius and center of the circles that make up the ends of the portion of the lens.		
Voltage ratio equations, source impedance equation with infeed formulae applied, and circle equations.		
Given:	$E_S = 0.7$	$E_R = 1.0$
Eq. (95)	$N_a = \frac{ E_S }{ E_R } = \frac{0.7}{1.0} = 0.7$	
Eq. (96)	$N_b = \frac{ E_R }{ E_S } = \frac{1.0}{0.7} = 1.43$	
The total system impedance as seen by the relay with infeed formulae applied.		
Given:	$Z_S = 2 + j10 \Omega$	$Z_L = 4 + j20 \Omega$ $Z_R = 4 + j20 \Omega$
Given:	$Z_{TR} = Z_L \times 10^{10} \Omega$	
	$Z_{TR} = (4 + j20)^{10} \Omega$	
Eq. (97)	$Z_{sys} = Z_S \times \left(1 + \frac{Z_L}{Z_{TR}}\right) + \left[Z_L + Z_R \times \left(1 + \frac{Z_L}{Z_{TR}}\right)\right]$	
	$Z_{sys} = 10 + j50 \Omega$	
The calculated coordinates of the lower circle center.		
Eq. (98)	$Z_{C1} = - \left[ Z_S \times \left(1 + \frac{Z_L}{Z_{TR}}\right) \right] - \left[ \frac{N_a^2 \times Z_{sys}}{1 - N_a^2} \right]$	
	$Z_{C1} = - \left[ (2 + j10) \Omega \times \left(1 + \frac{(4 + j20) \Omega}{(4 + j20)^{10} \Omega}\right) \right] - \left[ \frac{0.7^2 \times (10 + j50) \Omega}{1 - 0.7^2} \right]$	
	$Z_{C1} = -11.608 - j58.039 \Omega$	
The calculated radius of the lower circle.		
Eq. (99)	$r_a = \left[ \frac{N_a \times Z_{sys}}{1 - N_a^2} \right]$	
	$r_a = \left[ \frac{0.7 \times (10 + j50) \Omega}{1 - 0.7^2} \right]$	
	$r_a = 69.987 \Omega$	

<sup>15</sup> <http://store.gedigitalenergy.com/faq/Documents/Alps/GER-3180.pdf>

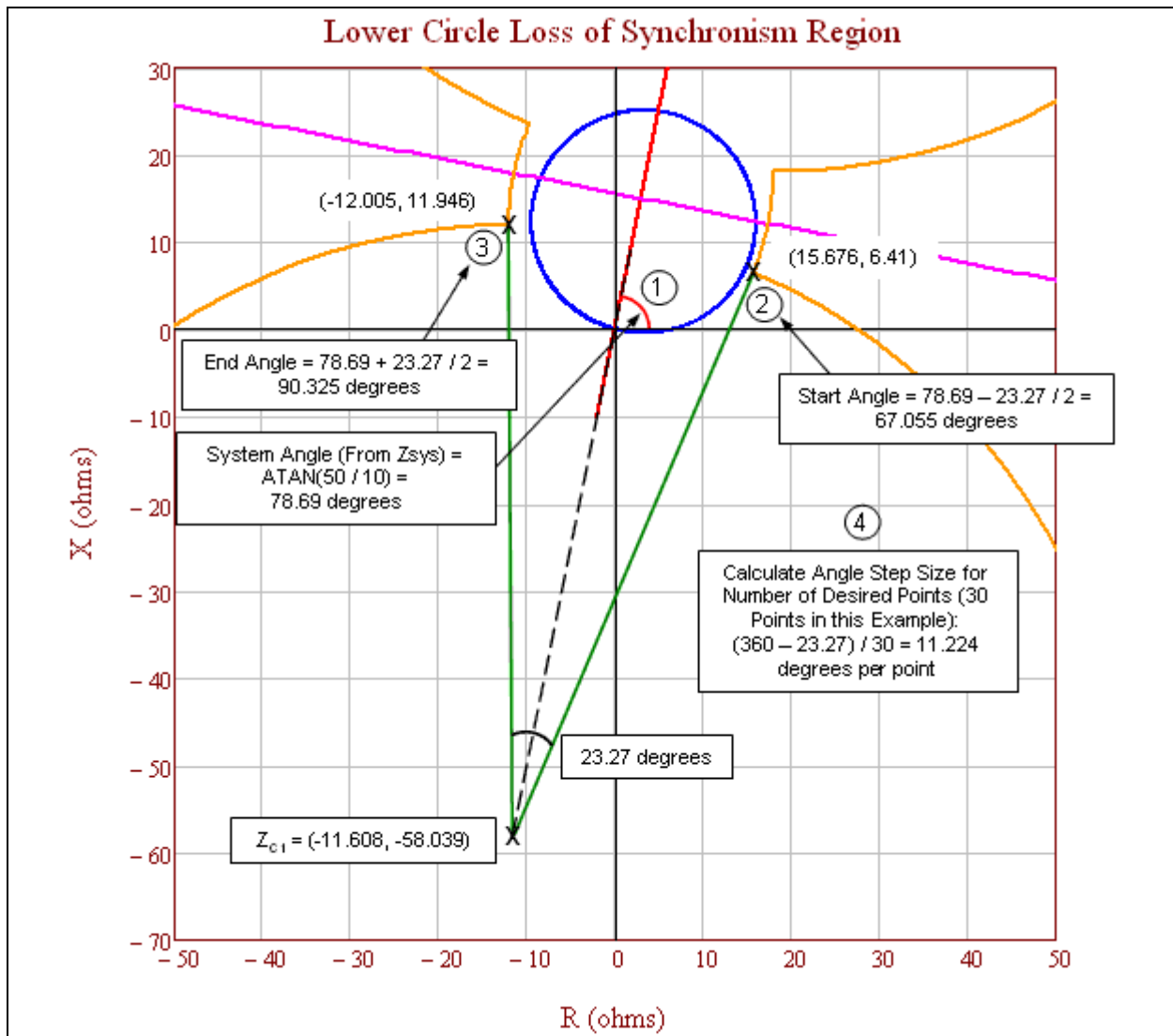


Table 13. Example Calculation (Voltage Ratios)	
The calculated coordinates of the upper circle center.	
Eq. (100)	$Z_{C2} = Z_L + \left[ Z_R \times \left( 1 + \frac{Z_L}{Z_{TR}} \right) \right] + \left[ \frac{Z_{sys}}{N_b^2 - 1} \right]$
	$Z_{C2} = - \left[ (4 + j20) \Omega \times \left( 1 + \frac{(4 + j20) \Omega}{(4 + j20)^{10} \Omega} \right) \right] + \left[ \frac{(10 + j50) \Omega}{1.43^2 - 1} \right]$
	$Z_{C2} = 17.608 + j88.039 \Omega$
The calculated radius of the upper circle.	
Eq. (101)	$r_b = \left[ \frac{N_b \times Z_{sys}}{N_b^2 - 1} \right]$
	$r_b = \left[ \frac{1.43 \times (10 + j50) \Omega}{1.43^2 - 1} \right]$
	$r_b = 69.987 \Omega$

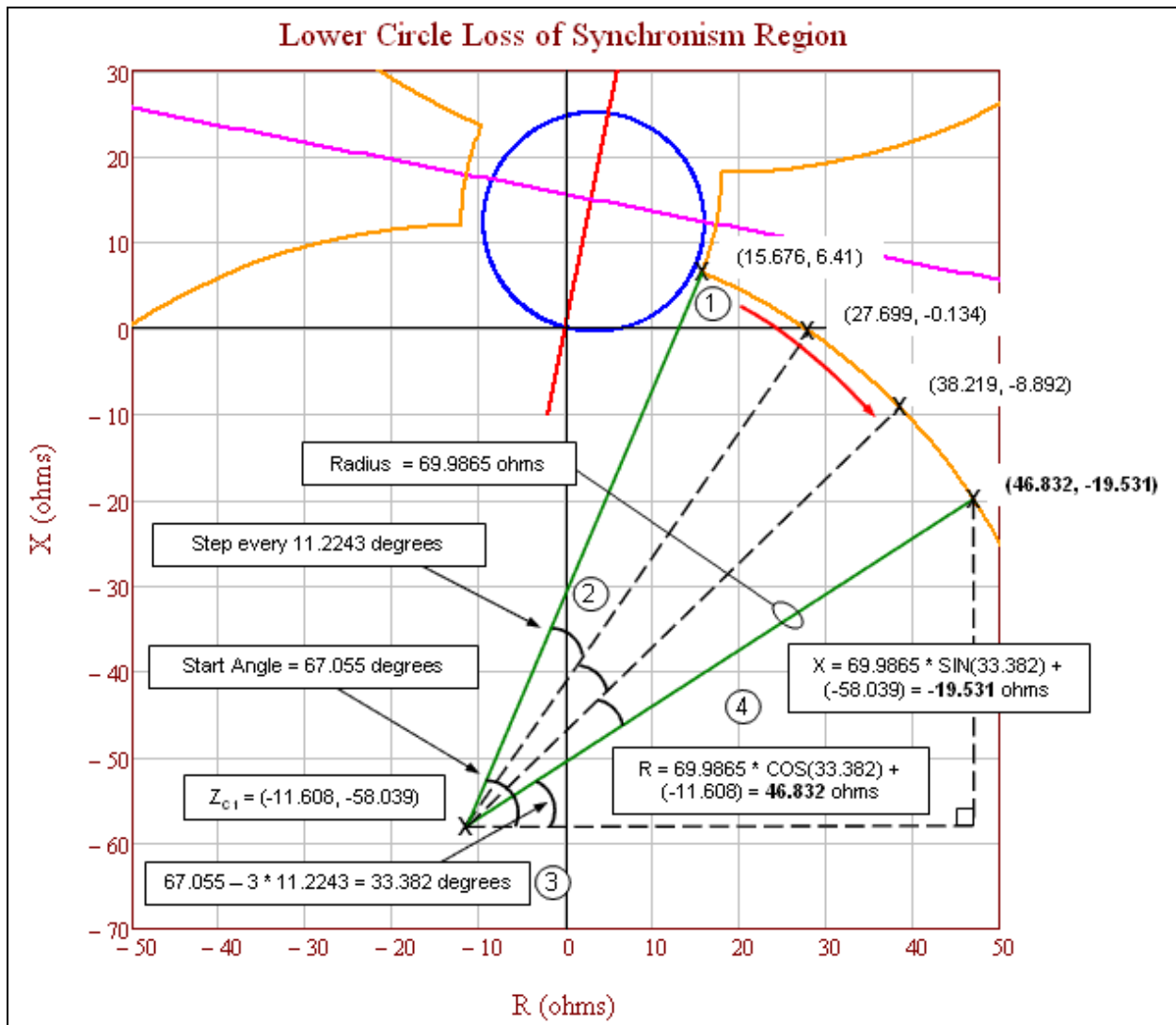




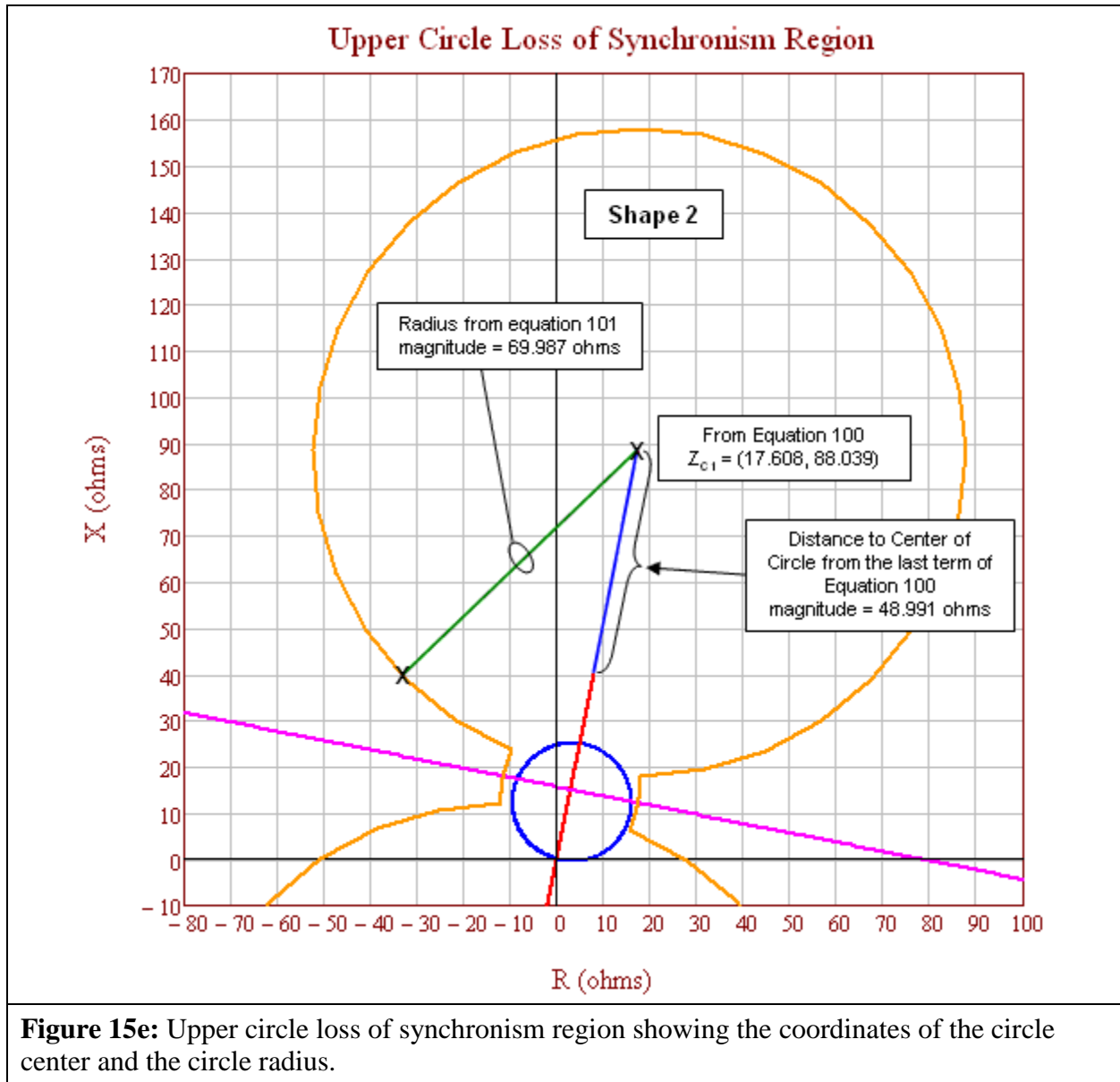
**Figure 15b:** Lower circle loss of synchronism region showing the first steps to calculate the coordinates of the points on the circle. 1) Identify the lower circle points that intersect the lens shape where the sending-end to receiving-end voltage ratio is 0.7 (see lens shape calculations in Tables 2-7). 2) Calculate the distance between the two lower circle points identified in Step 1. 3) Calculate the angle of arc that connects the two lower circle points identified in Step 1.

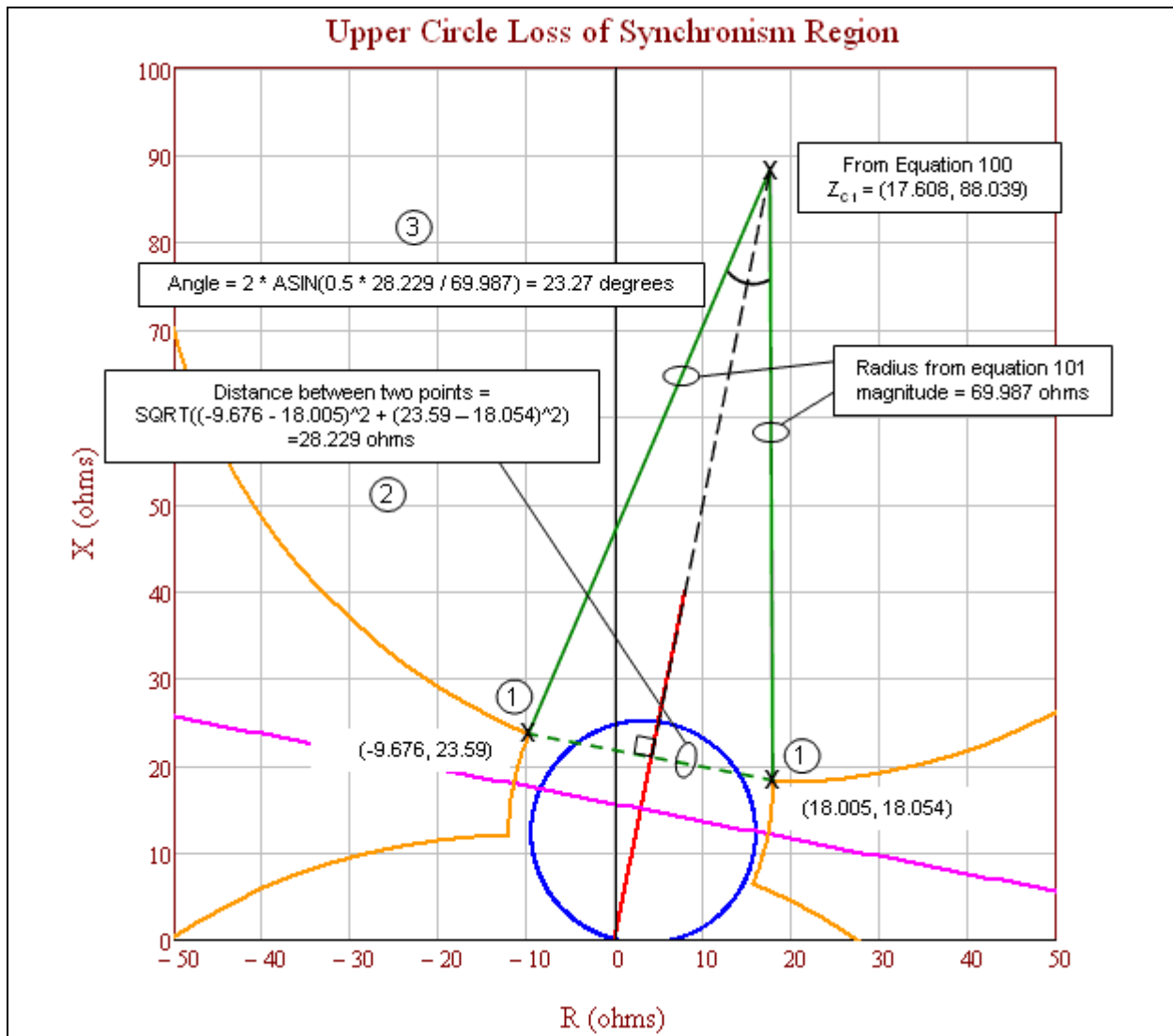


**Figure 15c:** Lower circle loss of synchronism region showing the steps to calculate the start angle, end angle, and the angle step size for the desired number of calculated points. 1) Calculate the system angle. 2) Calculate the start angle. 3) Calculate the end angle. 4) Calculate the angle step size for the desired number of points.

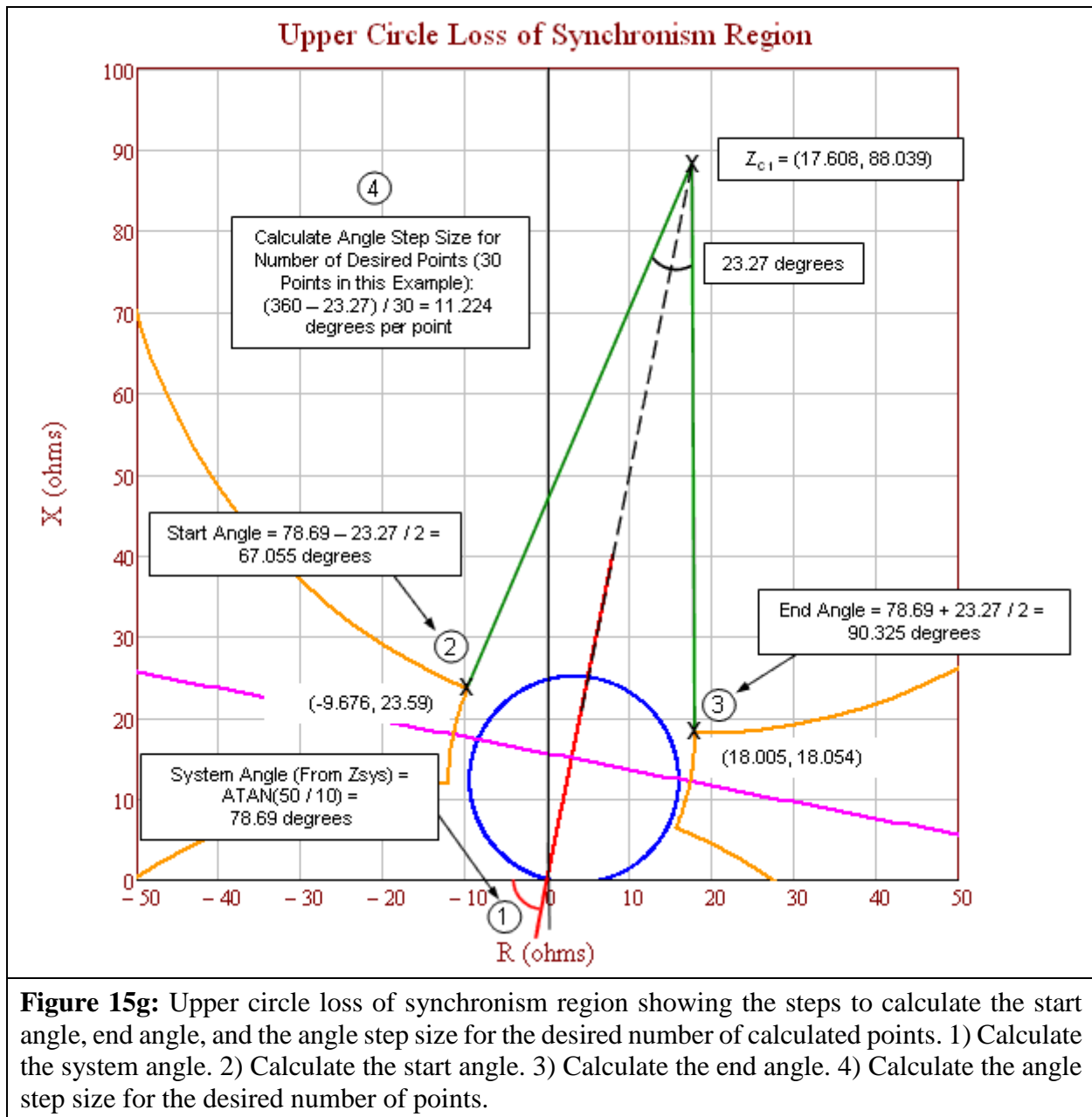


**Figure 15d:** Lower circle loss of synchronism region showing the final steps to calculate the coordinates of the points on the circle. 1) Start at the intersection with the lens shape and proceed in a clockwise direction. 2) Advance the step angle for each point. 3) Calculate the new angle after step advancement. 4) Calculate the R–X coordinates.



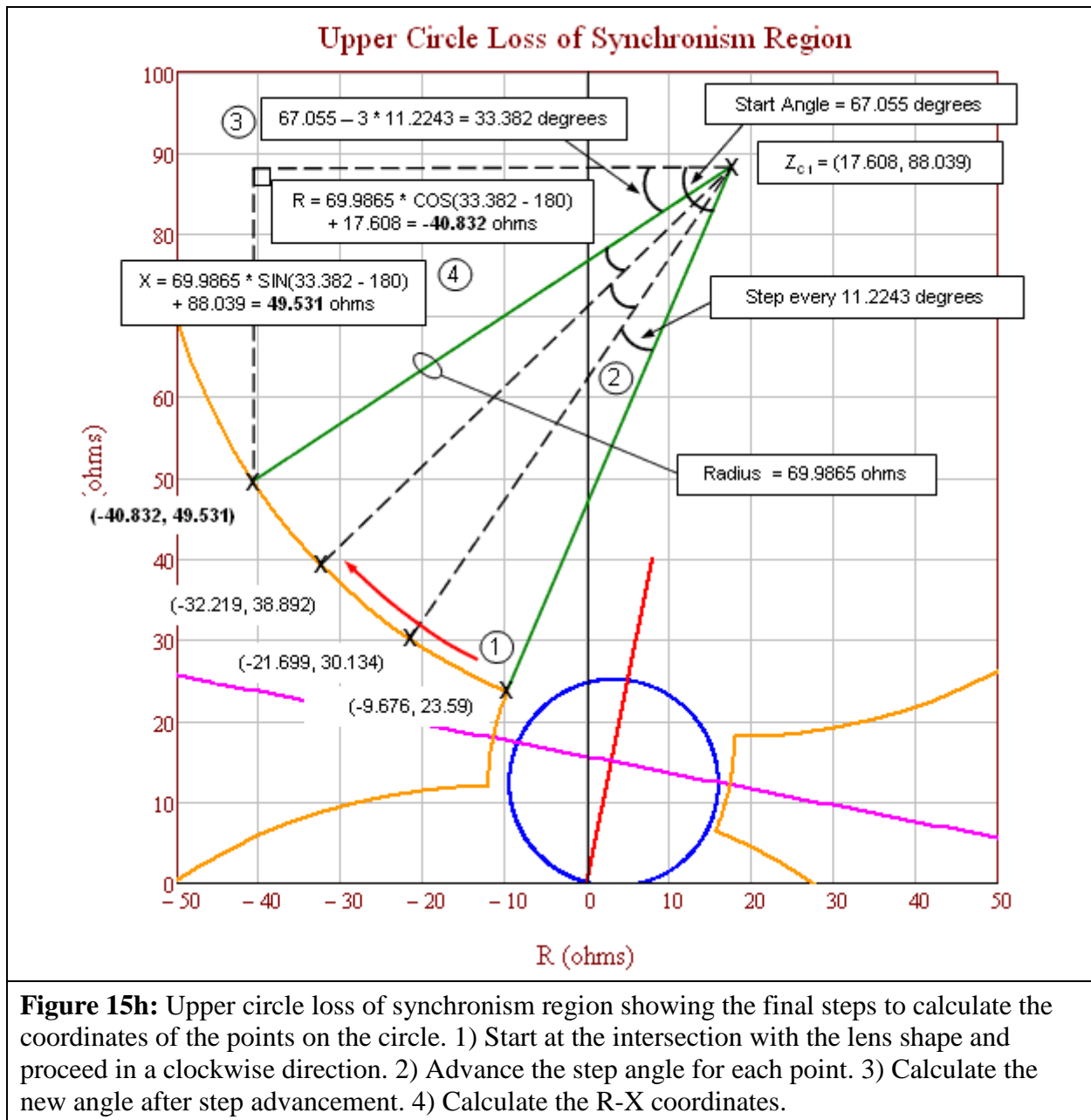


**Figure 15f:** Upper circle loss of synchronism region showing the first steps to calculate the coordinates of the points on the circle. 1) Identify the upper circle points that intersect the lens shape where the sending-end to receiving-end voltage ratio is 1.43 (see lens shape calculations in Tables 2-7). 2) Calculate the distance between the two upper circle points identified in Step 1. 3) Calculate the angle of arc that connects the two upper circle points identified in Step 1.



**Figure 15g:** Upper circle loss of synchronism region showing the steps to calculate the start angle, end angle, and the angle step size for the desired number of calculated points. 1) Calculate the system angle. 2) Calculate the start angle. 3) Calculate the end angle. 4) Calculate the angle step size for the desired number of points.





Lower Loss of Synchronism Circle Coordinates			Upper Loss of Synchronism Circle Coordinates		
Angle (degrees)	R	+ jX	Angle (degrees)	R	+ jX
67.055	15.676	6.41	67.055	-9.676	23.59
55.831	27.699	-0.134	55.831	-21.699	30.134
44.606	38.219	-8.892	44.606	-32.219	38.892
<b>33.382</b>	<b>46.832</b>	<b>-19.531</b>	<b>33.382</b>	<b>-40.832</b>	<b>49.531</b>
22.158	53.21	-31.643	22.158	-47.21	61.643
10.933	57.108	-44.765	10.933	-51.108	74.765
359.709	58.378	-58.395	359.709	-52.378	88.395
348.485	56.97	-72.011	348.485	-50.97	102.011
337.26	52.939	-85.092	337.26	-46.939	115.092
326.036	46.438	-97.139	326.036	-40.438	127.139
314.812	37.717	-107.69	314.812	-31.717	137.69
303.587	27.109	-116.341	303.587	-21.109	146.341
292.363	15.02	-122.762	292.363	-9.02	152.762
281.139	1.913	-126.707	281.139	4.087	156.707
269.914	-11.712	-128.026	269.914	17.712	158.026
258.69	-25.333	-126.667	258.69	31.333	156.667
247.466	-38.429	-122.682	247.466	44.429	152.682
236.241	-50.499	-116.225	236.241	56.499	146.225
225.017	-61.081	-107.542	225.017	67.081	137.542
213.793	-69.771	-96.965	213.793	75.771	126.965
202.568	-76.235	-84.899	202.568	82.235	114.899
191.344	-80.227	-71.806	191.344	86.227	101.806
180.12	-81.594	-58.185	180.12	87.594	88.185
168.895	-80.284	-44.56	168.895	86.284	74.56
157.671	-76.347	-31.45	157.671	82.347	61.45
146.447	-69.933	-19.357	146.447	75.933	49.357
135.222	-61.288	-8.744	135.222	67.288	38.744
123.998	-50.742	-0.016	123.998	56.742	30.016
112.774	-38.699	6.491	112.774	44.699	23.509
101.549	-25.62	10.53	101.549	31.62	19.47
90.325	-12.005	11.946	90.325	18.005	18.054

**Figure 15i:** Full tables of calculated lower and upper loss of synchronism circle coordinates. The highlighted row is the detailed calculated points in Figures 15d and 15h.

### Application Specific to Criteria B

The PRC-026-1 – Attachment B, Criteria B evaluates overcurrent elements used for tripping. The same criteria as PRC-026-1 – Attachment B, Criteria A is used except for an additional criteria (No. 4) that calculates a current magnitude based upon generator terminal voltages of 1.05 per unit. The formula used to calculate the current is as follows:

**Table 14. Example Calculation (Overcurrent)**

This example is for a 230 kV line terminal with a directional instantaneous phase overcurrent element set to 50 amps secondary times a CT ratio of 160:1 that equals 8,000 amps, primary. The following calculation is where  $V_S$  equals the base line-to-ground sending-end generator source voltage times 1.05 at an angle of 120 degrees,  $V_R$  equals the base line-to-ground receiving-end generator terminal voltage times 1.05 at an angle of 0 degrees, and  $Z_{sys}$  equals the sum of the sending-end, line, and receiving-end source impedances in ohms.

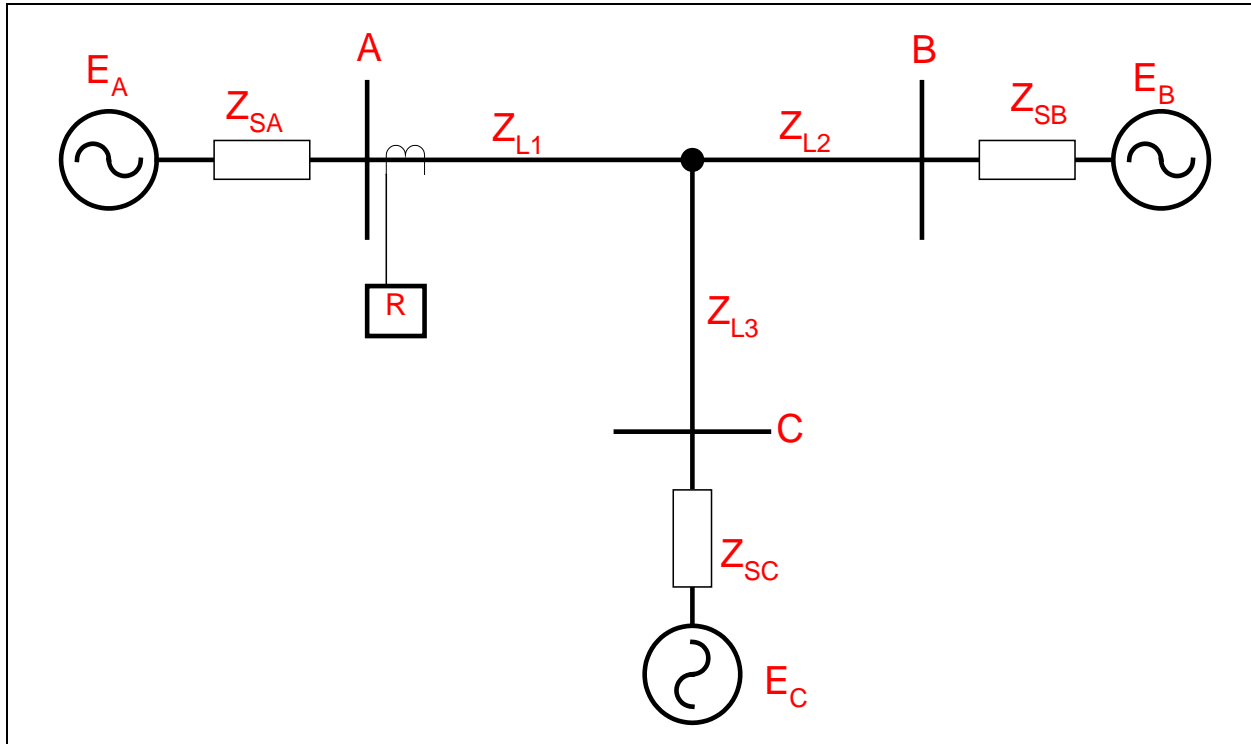
Here, the phase instantaneous setting of 8,000 amps is greater than the calculated system current of 5,716 amps; therefore, it meets PRC-026-1 – Attachment B, Criteria B.

Eq. (102)	$V_S = \frac{V_{LL} \angle 120^\circ}{\sqrt{3}} \times 1.05$		
	$V_S = \frac{230,000 \angle 120^\circ V}{\sqrt{3}} \times 1.05$		
	$V_S = 139,430 \angle 120^\circ V$		
Receiving-end generator terminal voltage.			
Eq. (103)	$V_R = \frac{V_{LL} \angle 0^\circ}{\sqrt{3}} \times 1.05$		
	$V_R = \frac{230,000 \angle 0^\circ V}{\sqrt{3}} \times 1.05$		
	$V_R = 139,430 \angle 0^\circ V$		
The total impedance of the system ( $Z_{sys}$ ) equals the sum of the sending-end source impedance ( $Z_S$ ), the impedance of the line ( $Z_L$ ), and receiving-end impedance ( $Z_R$ ) in ohms.			
Given:	$Z_S = 3 + j26 \Omega$	$Z_L = 1.3 + j8.7 \Omega$	$Z_R = 0.3 + j7.3 \Omega$
Eq. (104)	$Z_{sys} = Z_S + Z_L + Z_R$		
	$Z_{sys} = (3 + j26) \Omega + (1.3 + j8.7) \Omega + (0.3 + j7.3) \Omega$		
	$Z_{sys} = 4.6 + j42 \Omega$		
Total system current from sending-end source.			
Eq. (105)	$I_{sys} = \frac{(V_S - V_R)}{Z_{sys}}$		
	$I_{sys} = \frac{(139,430 \angle 120^\circ V - 139,430 \angle 0^\circ V)}{(4.6 + j42) \Omega}$		
	$I_{sys} = 5,715.82 \angle 66.25^\circ A$		

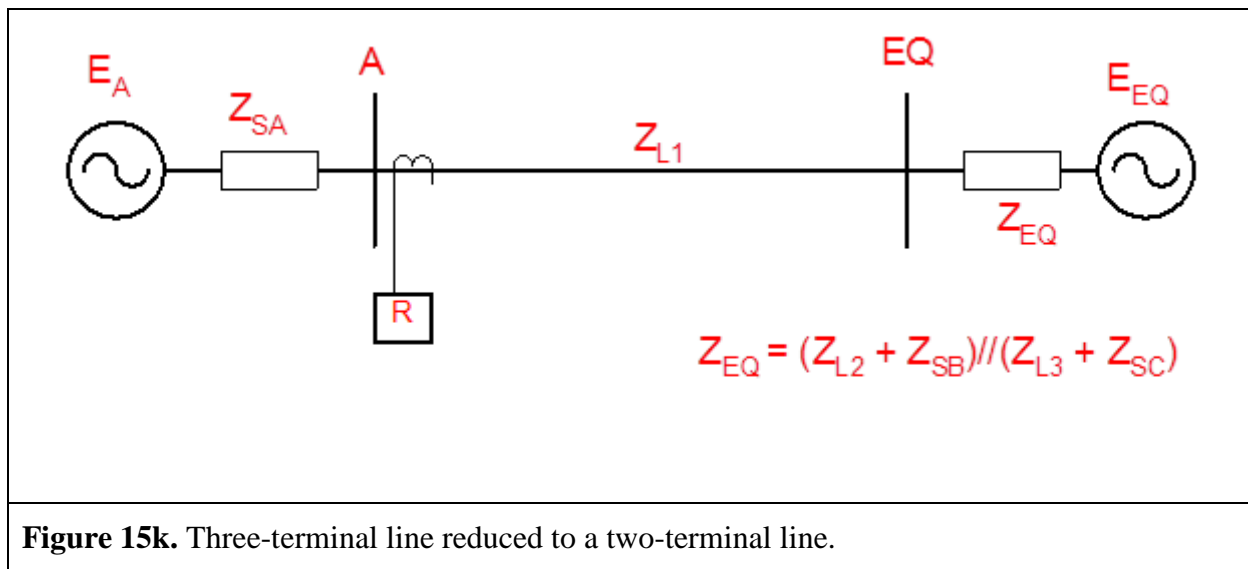
### Application Specific to Three-Terminal Lines

If a three-terminal line is identified as an Element that is susceptible to a power swing based on Requirement R1, the load-responsive protective relays at each end of the three-terminal line must be evaluated.

As shown in Figure 15j, the source impedances at each end of the line can be obtained from the similar short circuit calculation as for the two-terminal line.



**Figure 15j.** Three-terminal line. To evaluate the load-responsive protective relays on the three-terminal line at Terminal A, the circuit in Figure 15j is first reduced to the equivalent circuit shown in Figure 15k. The evaluation process for the load-responsive protective relays on the line at Terminal A will now be the same as that of the two-terminal line.



**Figure 15k.** Three-terminal line reduced to a two-terminal line.

### Application to Generation Elements

As with transmission BES Elements, the determination of the apparent impedance seen at an Element located at, or near, a generation Facility is complex for power swings due to various interdependent quantities. These variances in quantities are caused by changes in machine internal voltage, speed governor action, voltage regulator action, the reaction of other local generators, and the reaction of other interconnected transmission BES Elements as the event progresses through the time domain. Though transient stability simulations may be used to determine the apparent impedance for verifying load-responsive relay settings,<sup>16,17</sup> Requirement R2, PRC-026-1 – Attachment B, Criteria A and B provides a simplified method for evaluating the load-responsive protective relay’s susceptibility to tripping in response to a stable power swing without requiring stability simulations.

In general, the electrical center will be in the transmission system for cases where the generator is connected through a weak transmission system (high external impedance). Other cases where the generator is connected through a strong Transmission system, the electrical center could be inside the unit connected zone.<sup>18</sup> In either case, load-responsive protective relays connected at the generator terminals or at the high-voltage side of the generator step-up (GSU) transformer may be challenged by power swings as determined by the Planning Coordinator in Requirement R1 or becoming aware of a generator, transformer, or transmission line BES Element that tripped<sup>19</sup> in

<sup>16</sup> Donald Reimert, *Protective Relaying for Power Generation Systems*, Boca Raton, FL, CRC Press, 2006.

<sup>17</sup> Prabha Kundur, *Power System Stability and Control*, EPRI, McGraw Hill, Inc., 1994.

<sup>18</sup> Ibid, Kundur.

<sup>19</sup> See Guidelines and Technical Basis section, “Becoming Aware of an Element That Tripped in Response to a Power Swing,”

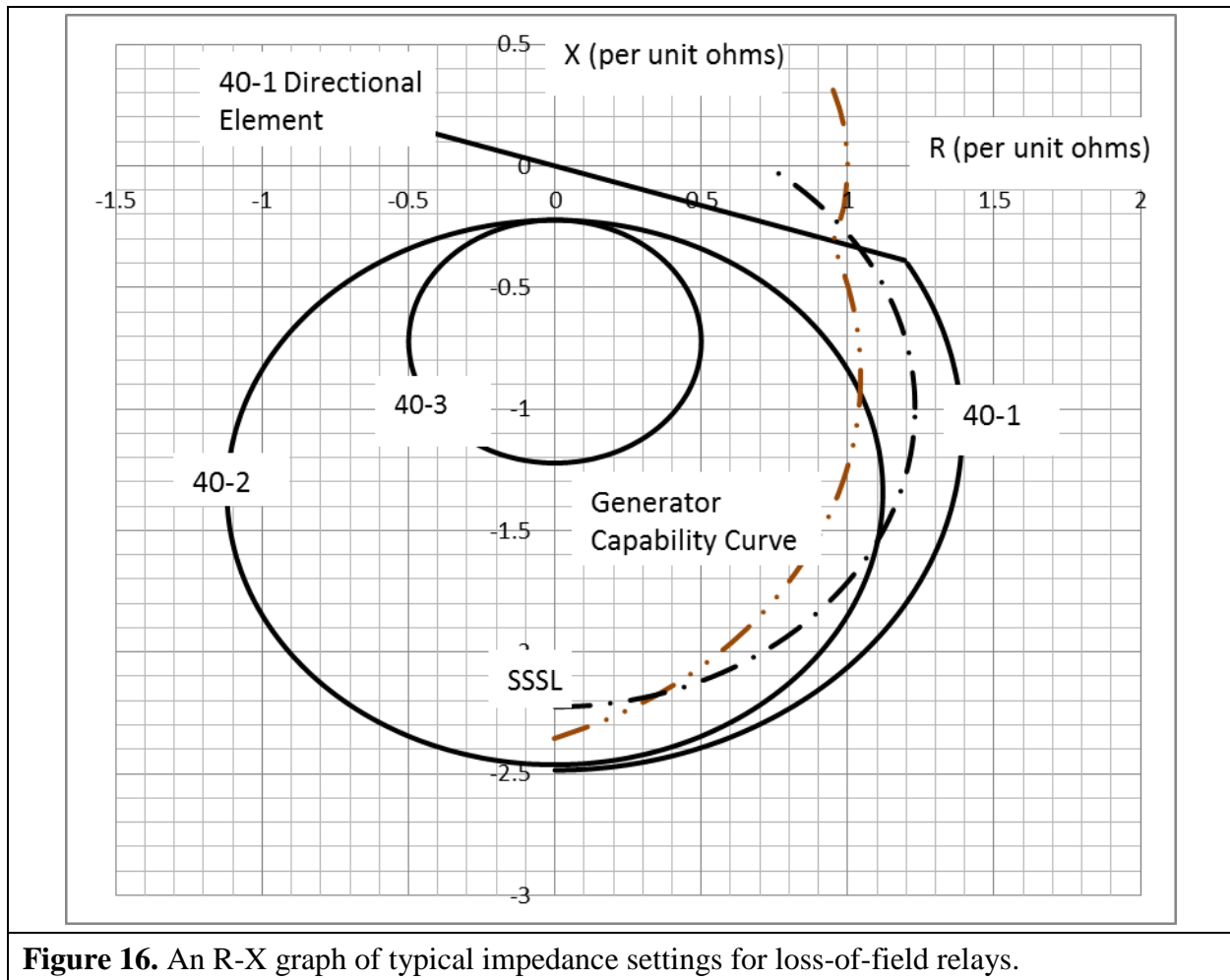
## PRC-026-1 – Application Guidelines

response to stable or unstable power swing due to the operation of its protective relay(s) in Requirement R2.

Load-responsive protective relays such as time over-current, voltage controlled time-overcurrent or voltage-restrained time-overcurrent relays are excluded from this standard if they are set based on equipment permissible overload capability. Their operating time is much greater than 15 cycles for the current levels observed during a power swing.

Instantaneous overcurrent and definite-time overcurrent relays with a time delay of less than 15 cycles are applicable and are required to be evaluated for identified Elements.

The generator loss-of-field protective function is provided by impedance relay(s) connected at the generator terminals. The settings are applied to protect the generator from a partial or complete loss of excitation under all generator loading conditions and, at the same time, be immune to tripping on stable power swings. It is more likely that the relay would operate during a power swing when the automatic voltage regulator (AVR) is in manual mode rather than when in automatic mode.<sup>20</sup> Figure 16 illustrates the loss-of-field relay in the R-X plot, which typically includes up to three zones of protection.



**Figure 16.** An R-X graph of typical impedance settings for loss-of-field relays.

<sup>20</sup> John Burdy, *Loss-of-excitation Protection for Synchronous Generators GER-3183*, General Electric Company.

Loss-of-field characteristic 40-1 has a wider impedance characteristic (positive offset) than characteristic 40-2 or characteristic 40-3 and provides additional generator protection for a partial loss of field or a loss of field under low load (less than 10% of rated). The tripping logic of this protection scheme is established by a directional contact, a voltage setpoint, and a time delay. The voltage and time delay add security to the relay operation for stable power swings. Characteristic 40-3 is less sensitive to power swings than characteristic 40-2 and is set outside the generator capability curve in the leading direction. Regardless of the relay impedance setting, PRC-019<sup>21</sup> requires that the “in-service limiters operate before Protection Systems to avoid unnecessary trip” and “in-service Protection System devices are set to isolate or de-energize equipment in order to limit the extent of damage when operating conditions exceed equipment capabilities or stability limits.” Time delays for tripping associated with loss-of-field relays<sup>22,23</sup> have a range from 15 cycles for characteristic 40-2 to 60 cycles for characteristic 40-1 to minimize tripping during stable power swings. In the standard, 15 cycles establishes a threshold for applicability; however, it is the responsibility of the Generator Owner to establish settings that provide security against stable power swings and, at the same time, dependable protection for the generator.

The simple two-machine system circuit (method also used in the Application to Transmission Elements section) is used to analyze the effect of a power swing at a generator facility for load-responsive relays. In this section, the calculation method is used for calculating the impedance seen by the relay connected at a point in the circuit.<sup>24</sup> The electrical quantities used to determine the apparent impedance plot using this method are generator saturated transient reactance ( $X'_d$ ), GSU transformer impedance ( $X_{GSU}$ ), transmission line impedance ( $Z_L$ ), and the system equivalent ( $Z_e$ ) at the point of interconnection. All impedance values are known to the Generator Owner except for the system equivalent. The system equivalent is obtainable from the Transmission Owner. The sending-end and receiving-end source voltages are varied from 0.0 to 1.0 per unit to form the lens shape of the unstable power swing region. The voltage range of 0.7 to 1.0 results in a ratio range from 0.7 to 1.43. This ratio range is used to form the lower and upper loss-of-synchronism circle shapes of the unstable power swing region. A system separation angle of 120 degrees is used in accordance with PRC-026-1 – Attachment B criteria for each load-responsive protective relay evaluation.

Table 15 below is an example calculation of the apparent impedance locus method based on Figures 17 and 18.<sup>25</sup> In this example, the generator is connected to the 345 kV transmission system through the GSU transformer and has the listed ratings. Note that the load-responsive protective relays in this example may have ownership with the Generator Owner or the Transmission Owner.

---

<sup>21</sup> Coordination of Generating Unit or Plant Capabilities, Voltage Regulating Controls, and Protection

<sup>22</sup> Ibid, Burdy.

<sup>23</sup> *Applied Protective Relaying*, Westinghouse Electric Corporation, 1979.

<sup>24</sup> Edward Wilson Kimbark, *Power System Stability, Volume II: Power Circuit Breakers and Protective Relays*, Published by John Wiley and Sons, 1950.

<sup>25</sup> Ibid, Kimbark.

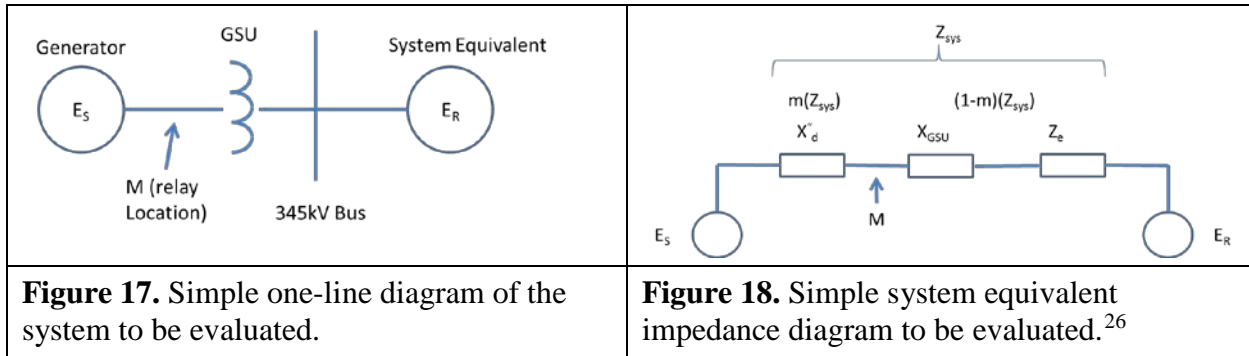


Table15. Example Data (Generator)	
Input Descriptions	Input Values
Synchronous Generator nameplate (MVA)	940 MVA
Sub-transient reactance (940MVA base)	$X'_d = 0.3845$ (per unit)
Generator rated voltage (Line-to-Line)	20 kV
Generator step-up (GSU) transformer rating	880 MVA
GSU transformer reactance (880 MVA base)	$X_{GSU} = 16.05\%$
System Equivalent (100 MVA base)	$Z_e = 0.00723 \angle 86^\circ$ ohms
Generator Owner Load-Responsive Protective Relays	
40-1	Positive Offset Impedance
	Offset = 0.294 per unit ohms
	Diameter = 0.294 per unit ohms
40-2	Negative Offset Impedance
	Offset = 0.22 per unit ohms
	Diameter = 2.24 per unit ohms
40-3	Negative Offset Impedance
	Offset = 0.22 per unit ohms
	Diameter = 1.00 per unit ohms
21-1	Diameter = 0.643 per unit ohms
	MTA = 85°

<sup>26</sup> Ibid, Kimbark.



Table15. Example Data (Generator)	
50	I (pickup) = 5.0 per unit
Transmission Owned Load-Responsive Protective Relays	
21-2	Diameter = 0.55 per unit ohms
	MTA = 85°

Calculations shown for a 120 degree angle and  $E_S/E_R = 1$ . The equation for calculating  $Z_R$  is:<sup>27</sup>

$$\text{Eq. (106)} \quad Z_R = \left( \frac{(1 - m)(E_S \angle \delta) + (m)(E_R)}{E_S \angle \delta - E_R} \right) \times Z_{sys}$$

Where m is the relay location as a function of the total impedance (real number less than 1)

$E_S$  and  $E_R$  is the sending-end and receiving-end voltages

$Z_{sys}$  is the total system impedance

$Z_R$  is the complex impedance at the relay location and plotted on an R-X diagram

All of the above are constants (940 MVA base) while the angle  $\delta$  is varied. Table 16 below contains calculations for a generator using the data listed in Table 15.

Table16. Example Calculations (Generator)			
Given:	$X'_d = j0.3845 \Omega$	$X_{GSU} = j0.171 \Omega$	$Z_e = 0.06796 \Omega$
Eq. (107)	$Z_{sys} = X'_d + X_{GSU} + Z_e$		
	$Z_{sys} = j0.3845 \Omega + j0.171 \Omega + 0.06796 \Omega$		
	$Z_{sys} = 0.6239 \angle 90^\circ \Omega$		
Eq. (108)	$m = \frac{X'_d}{Z_{sys}} = \frac{0.3845}{0.6239} = 0.61633$		
Eq. (109)	$Z_R = \left( \frac{(1 - m)(E_S \angle \delta) + (m)(E_R)}{E_S \angle \delta - E_R} \right) \times Z_{sys}$		
	$Z_R = \left( \frac{(1 - 0.61633) \times (1 \angle 120^\circ) + (0.61633)(1 \angle 0^\circ)}{1 \angle 120^\circ - 1 \angle 0^\circ} \right) \times (0.6234 \angle 90^\circ) \Omega$		
	$Z_R = \left( \frac{0.4244 + j0.3323}{-1.5 + j 0.866} \right) \times (0.6234 \angle 90^\circ) \Omega$		
	$Z_R = (0.3112 \angle - 111.94^\circ) \times (0.6234 \angle 90^\circ) \Omega$		

<sup>27</sup> Ibid, Kimbark.

Table16. Example Calculations (Generator)	
	$Z_R = 0.194 \angle -21.94^\circ \Omega$
	$Z_R = -0.18 - j0.073 \Omega$

Table 17 lists the swing impedance values at other angles and at  $E_S/E_R = 1, 1.43,$  and  $0.7$ . The impedance values are plotted on an R-X graph with the center being at the generator terminals for use in evaluating impedance relay settings.

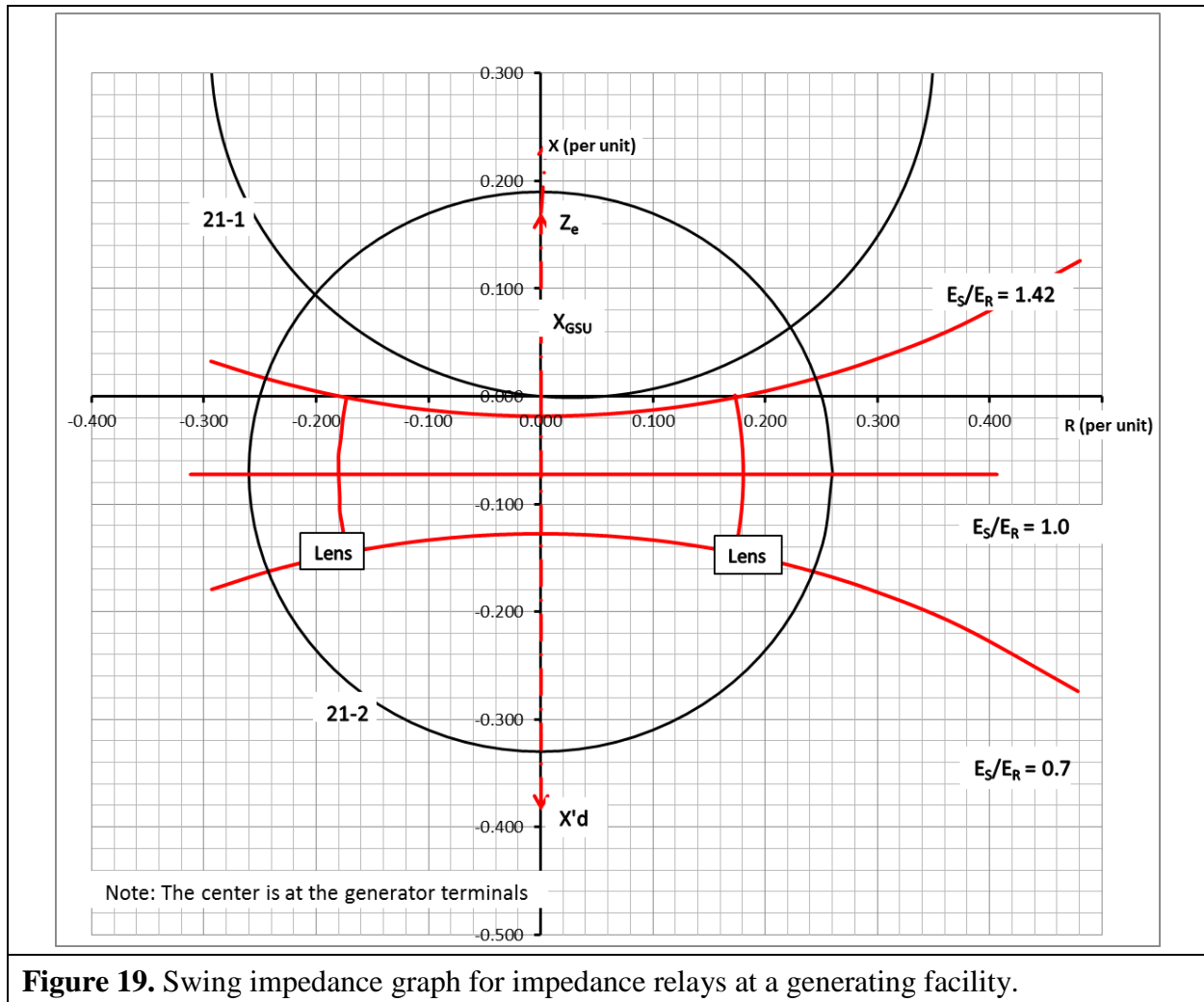
Table 17: Sample calculations for a swing impedance chart for varying voltages at the sending-end and receiving-end.						
Angle ( $\delta$ ) (Degrees)	$E_S/E_R=1$		$E_S/E_R=1.43$		$E_S/E_R=0.7$	
	$Z_R$		$Z_R$		$Z_R$	
	Magnitude (PU Ohms)	Angle (Degrees)	Magnitude (PU Ohms)	Angle (Degrees)	Magnitude (PU Ohms)	Angle (Degrees)
90	0.320	-13.1	0.296	6.3	0.344	-31.5
120	0.194	-21.9	0.173	-0.4	0.227	-40.1
150	0.111	-41.0	0.082	-10.3	0.154	-58.4
210	0.111	-25.9	0.082	190.3	0.154	238.4
240	0.194	201.9	0.173	180.4	0.225	220.1
270	0.320	193.1	0.296	173.7	0.344	211.5

## Requirement R2 Generator Examples

### *Distance Relay Application*

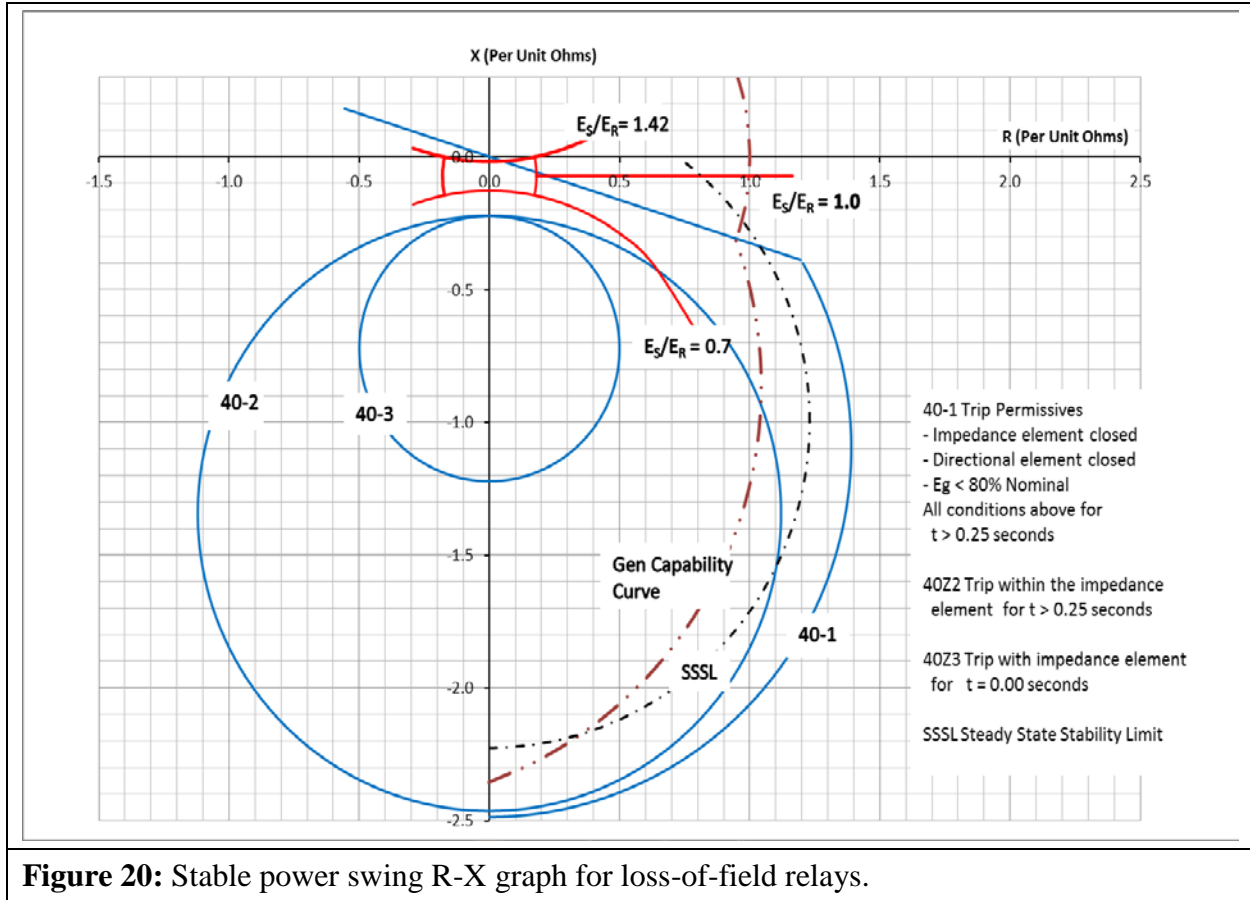
Based on PRC-026-1 – Attachment B, Criteria A, the distance relay (21-1) (i.e., owned by the Generation Owner) characteristic is in the region where a stable power swing would not occur as shown in Figure 19. There is no further obligation to the owner in this standard for this load-responsive protective relay.

The distance relay (21-2) (i.e., owned by the Transmission Owner) is connected at the high-voltage side of the GSU transformer and its impedance characteristic is in the region where a stable power swing could occur causing the relay to operate. In this example, if the intentional time delay of this relay is less than 15 cycles, the PRC-026 – Attachment B, Criteria B cannot be met, thus the Transmission Owner is required to create a CAP (Requirement R3). Some of the options include, but are not limited to, changing the relay setting (i.e., impedance reach, angle, time delay), modify the scheme (i.e., add PSB), or replace the Protection System. Note that the relay may be excluded from this standard if it has an intentional time delay equal to or greater than 15 cycles.



### Loss-of-Field Relay Application

In Figure 20, the R-X diagram shows the loss-of-field relay (40-1 and 40-2) characteristics are in the region where a stable power swing can cause a relay operation. Protective relay 40-1 would be excluded if it has an intentional time delay equal to or greater than 15 cycles. Similarly, 40-2 would be excluded if its intentional time delay is equal to or greater than 15 cycles. For example, if 40-1 has a time delay of 1 second and 40-2 has a time delay of 0.25 seconds, they are excluded and there is no further obligation on the Generator Owner in this standard for these relays. The loss-of-field relay characteristic 40-3 is outside the region where a stable power swing can cause a relay operation. In this case, the owner may select high speed tripping on operation of the 40-3 impedance element.



### Instantaneous Overcurrent Relay

In similar fashion to the transmission line overcurrent example calculation in Table 14, the instantaneous overcurrent relay minimum setting is established by PRC-026-1 – Attachment B, Criteria B. The solution is found by:

$$\text{Eq. (110)} \quad I_{sys} = \frac{E_S - E_R}{Z_{sys}}$$

As stated in the relay settings in Table 15, the relay is installed on the high-voltage side of the GSU transformer with a pickup of 5.0 per unit amps. The maximum allowable current is calculated below.

$$I_{sys} = \frac{(1.05 \angle 120^\circ - 1.05 \angle 0^\circ)}{0.6234 \angle 90^\circ} A$$

$$I_{sys} = \frac{1.775 \angle 150^\circ V}{0.6234 \angle 90^\circ \Omega} A$$

$$I_{sys} = 2.84 \angle 60^\circ A$$

The phase instantaneous setting of 5.0 per unit amps is greater than the calculated system current of 2.84 per unit amps; therefore, it meets the PRC-026-1 – Attachment B, Criteria B.

### ***Out-of-Step Tripping for Generation Facilities***

Out-of-step protection for the generator generally falls into three different schemes. The first scheme is a distance relay connected at the high-voltage side of the GSU transformer with the directional element looking toward the generator. Because this relay setting may be the same setting used for generator backup protection (see Requirement R2 Generator Examples, Distance Relay Application), it is susceptible to stable power swings and would require modification. Because this scheme is susceptible to stable power swings and any modification to the mho circle will jeopardize the overall protection of the out-of-step protection of the generator, available technical literature does not recommend using this scheme specifically for generator out-of-step protection. The second and third out-of-step Protection System schemes are commonly referred to as single and double blinder schemes. These schemes are installed or enabled for out-of-step protection using a combination of blinders, a mho element, and timers. The combination of these protective relay functions provides out-of-step protection and discrimination logic for stable and unstable power swings. Single blinder schemes use logic that discriminate between stable and unstable power swings by issuing a trip command after the first slip cycle. Double blinder schemes are more complex than the single blinder scheme and, depending on the settings of the inner blinder, a trip for a stable power swing may occur. While the logic discriminates between stable and unstable power swings in either scheme, it is important that the trip initiating blinders be set at an angle greater than the stability limit of 120 degrees to remove the possibility of a trip for a stable power swing. Below is a discussion of the double blinder scheme.

### ***Double Blinder Scheme***

The double blinder scheme is a method for measuring the rate of change of positive sequence impedance for out-of-step swing detection. The scheme compares a timer setting to the actual elapsed time required by the impedance locus to pass between two impedance characteristics. In this case, the two impedance characteristics are simple blinders, each set to a specific resistive reach on the R-X plane. Typically, the two blinders on the left half plane are the mirror images of those on the right half plane. The scheme typically includes a mho characteristic which acts as a starting element, but is not a tripping element.

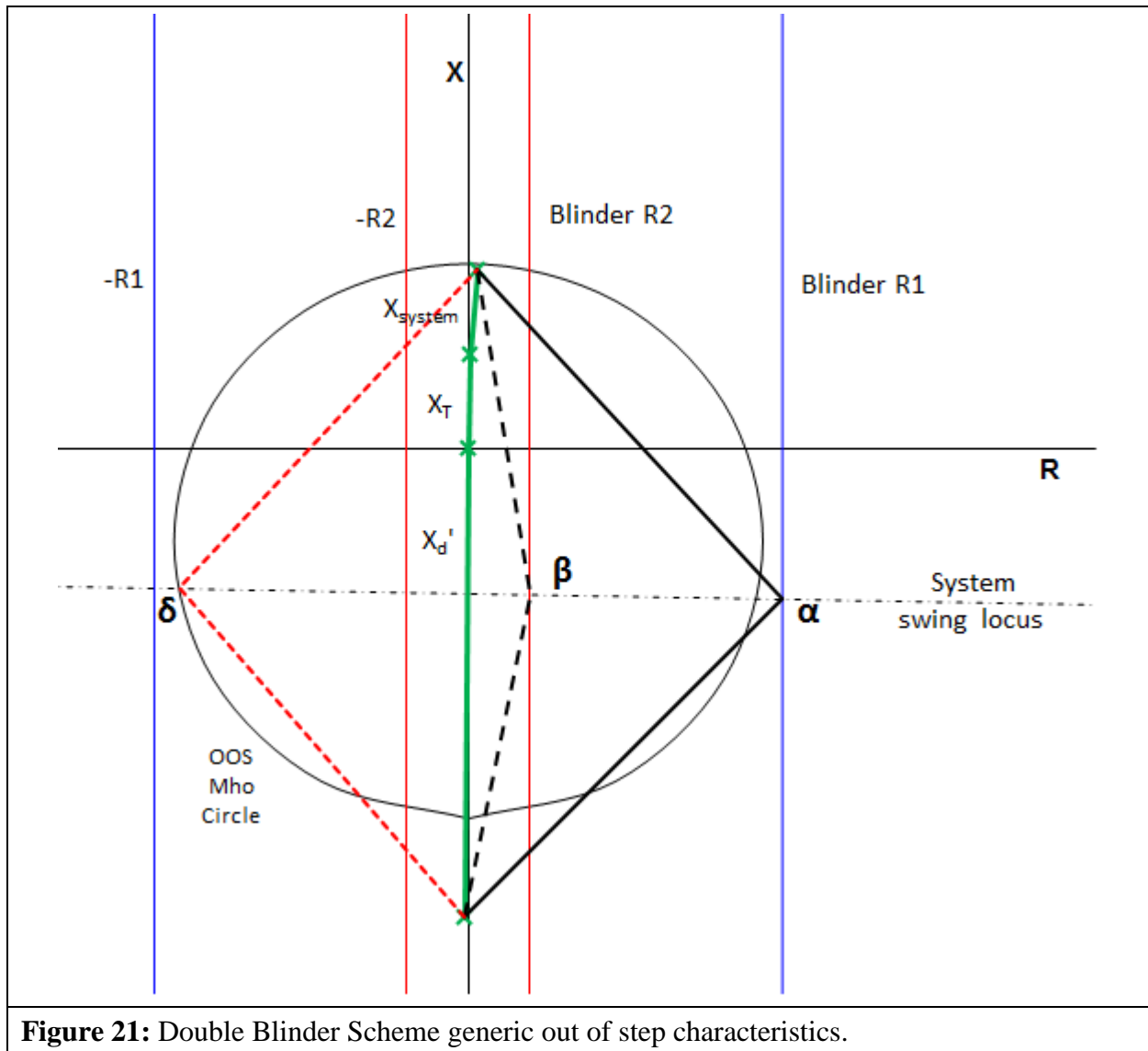
The scheme detects the blinder crossings and time delays as represented on the R-X plane as shown in Figure 21. The system impedance is composed of the generator transient ( $X_d'$ ), GSU transformer ( $X_T$ ), and transmission system ( $X_{system}$ ), impedances.

The scheme logic is initiated when the swing locus crosses the outer Blinder R1 (Figure 21), on the right at separation angle  $\alpha$ . The scheme only commits to take action when a swing crosses the inner blinder. At this point the scheme logic seals in the out-of-step trip logic at separation angle  $\beta$ . Tripping actually asserts as the impedance locus leaves the scheme characteristic at separation angle  $\delta$ .

The power swing may leave both inner and outer blinders in either direction and tripping will assert. Therefore, the inner blinder must be set such that the separation angle  $\beta$  is large enough

## PRC-026-1 – Application Guidelines

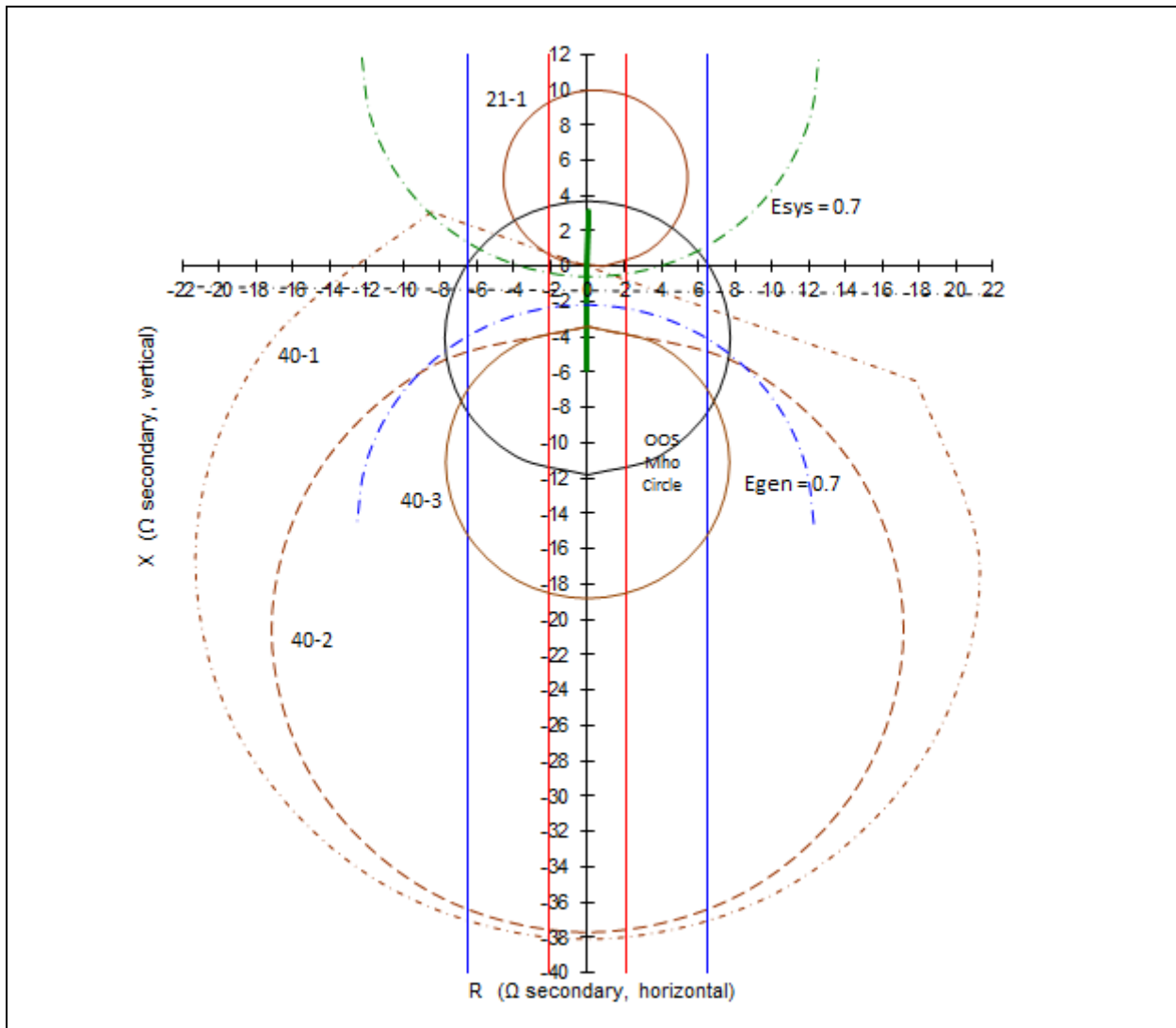
that the system cannot recover. This angle should be set at 120 degrees or more. Setting the angle greater than 120 degrees satisfies the PRC-026-1 – Attachment B Criteria A (No. 1, 1<sup>st</sup> bullet) since the tripping function is asserted by the blinder element. Transient stability studies are usually required to determine an appropriate inner blinder setting. Such studies may indicate that a smaller stability limit angle is acceptable under PRC-026-1 – Attachment B Criteria A (No. 1, 2<sup>nd</sup> bullet). In this respect, the double blinder scheme is similar to the double lens and triple lens schemes, and many transmission application out-of-step schemes.



**Figure 21:** Double Blinder Scheme generic out of step characteristics.

Figure 22 illustrates a sample setting of the double blinder scheme for example 940 MVA generator. The only setting requirement for this relay scheme is the right inner blinder, which must be set greater than the separation angle of 120 degrees (or a lesser angle based on a transient stability study) to ensure that the out-of-step protective function is expected to not trip in response to a stable power swing during non-Fault conditions. Other settings such as the mho

characteristic, outer blinders, and timers are set according to transient stability studies and are not a part of this standard.



**Figure 22:** Double Blinder Out-of-Step Scheme with unit impedance data and load-responsive protective relay impedance characteristics for the example 940 MVA generator, scaled in relay secondary ohms.

### Requirement R3

To achieve the stated purpose of this standard, which is to ensure that relays are expected to not trip in response to stable power swings during non-Fault conditions, this Requirement ensures that the applicable entity develops a Corrective Action Plan (CAP) that reduces the risk of relays tripping in response to a stable power swing during non-Fault conditions that may occur on any applicable BES Element.

### Requirement R4

To achieve the stated purpose of this standard, which is to ensure that load-responsive protective relays are expected to not trip in response to stable power swings during non-Fault conditions, the applicable entity is required to implement any CAP developed pursuant to Requirement R3 such that the Protection System will meet PRC-026-1 – Attachment B criteria or can be excluded under the PRC-026-1 – Attachment A criteria (e.g., modifying the Protection System so that relay functions are supervised by power swing blocking or using relay systems that are immune to power swings), while maintaining dependable fault detection and dependable out-of-step tripping (if out-of-step tripping is applied at the terminal of the BES Element). Protection System owners are required in the implementation of a CAP to update it when actions or timetable change, until all actions are complete. Accomplishing this objective is intended to reduce the occurrence of Protection System tripping during a stable power swing, thereby improving reliability and minimizing risk to the BES.

The following are examples of actions taken to complete CAPs for a relay that did not meet PRC-026-1 – Attachment B and could be at-risk of tripping in response to a stable power swing during non-Fault conditions. A Protection System change was determined to be acceptable (without diminishing the ability of the relay to protect for faults within its zone of protection).

**Example R4a:** Actions: Settings were issued on 6/02/2015 to reduce the Zone 2 reach of the impedance relay used in the directional comparison unblocking (DCUB) scheme from 30 ohms to 25 ohms so that the relay characteristic is completely contained within the lens characteristic identified by the criterion. The settings were applied to the relay on 6/25/2015. CAP was completed on 06/25/2015.

**Example R4b:** Actions: Settings were issued on 6/02/2015 to enable out-of-step blocking on the existing microprocessor-based relay to prevent tripping in response to stable power swings. The setting changes were applied to the relay on 6/25/2015. CAP was completed on 06/25/2015.

The following is an example of actions taken to complete a CAP for a relay responding to a stable power swing that required the addition of an electromechanical power swing blocking relay.

**Example R4c:** Actions: A project for the addition of an electromechanical power swing blocking relay to supervise the Zone 2 impedance relay was initiated on 6/5/2015 to prevent tripping in response to stable power swings. The relay installation was completed on 9/25/2015. CAP was completed on 9/25/2015.

The following is an example of actions taken to complete a CAP with a timetable that required updating for the replacement of the relay.

**Example R4d:** Actions: A project for the replacement of the impedance relays at both terminals of line X with line current differential relays was initiated on 6/5/2015 to prevent tripping in response to stable power swings. The completion of the project was postponed due to line outage rescheduling from 11/15/2015 to 3/15/2016. Following the timetable change, the impedance relay replacement was completed on 3/18/2016. CAP was completed on 3/18/2016.

The CAP is complete when all the documented actions to remedy the specific problem (i.e., unnecessary tripping during stable power swings) are completed.



## Standard Development Timeline

*This section is maintained by the drafting team during the development of the standard and will be removed when the standard becomes effective.*

### Development Steps Completed

1. Standards Authorization Request (SAR) posted for comment from August 19, 2010 through September 19, 2010.
2. Standards Committee (SC) authorized moving the SAR forward ~~to~~into standard development on August 12, 2010.
3. SC authorized initial posting of ~~draft~~Draft 1 on April 24, 2014.
4. Draft 1 of PRC-026-1 was posted for a 45-day formal comment period from April 25 – June 9, 2014 ~~and an~~with a concurrent/parallel initial ballot in the last ten days of the comment period from May 30 – June 9, 2014.
5. Draft 2 of PRC-026-1 was posted for an additional 45-day formal comment period from August 22 – October 6, 2014 with a concurrent/parallel additional ballot in the last ten days of the comment period from September 26 – October 6, 2014.
6. SC authorized a waiver of the Standards Process Manual on October 22, 2014 to reduce the Draft 3 additional formal comment period of PRC-026-1 from 45 days to 21 days with a concurrent/additional ballot period in the last ten days of the comment period.

### Description of Current Draft

The Protection System Response to Power Swings Standard Drafting Team (PSRPS SDT) is posting Draft ~~23~~ of PRC-026-1 – Relay Performance During Stable Power Swings for a ~~45~~21-day additional comment period and concurrent/parallel ~~additional~~additional ballot in the last ten days of the comment period.

Anticipated Actions	Anticipated Date
45-day Formal Comment Period with Concurrent/Parallel Initial <u>10-day</u> Ballot	April 2014
45-day Formal Comment Period with Concurrent/Parallel Additional <u>10-day</u> Ballot	August 2014
<u>Final Ballot 21-day Formal Comment Period with Concurrent/Parallel Additional 10-day Ballot (Standards Committee authorized a waiver of the Standards Process Manual, October 22, 2014)</u>	October 2014

## PRC-026-1 — Relay Performance During Stable Power Swings

---

<u>Final Ballot</u>	<u>December 2014</u>
NERC Board of Trustees Adoption	<del>November</del> <u>December</u> 2014

### Version History

Version	Date	Action	Change Tracking
1.0	TBD	Effective Date	New

### Definitions of Terms Used in Standard

*This section includes all newly defined or revised terms used in the proposed standard. Terms already defined in the Glossary of Terms Used in Reliability Standards ([Glossary](#)) are not repeated here. New or revised definitions listed below become approved when the proposed standard is approved. When the standard becomes effective, these defined terms will be removed from the individual standard and added to the Glossary.*

**Term:** None.

*When this standard has received ballot approval, the rationale boxes will be moved to the Application Guidelines Section of the Standard.*

## A. Introduction

1. **Title:** Relay Performance During Stable Power Swings
2. **Number:** **PRC-026-1**
3. **Purpose:** To ensure that load-responsive protective relays are expected to not trip in response to stable power swings during non-Fault conditions.
4. **Applicability:**
  - 4.1. **Functional Entities:**
    - 4.1.1 Generator Owner that applies load-responsive protective relays as described in PRC-026-1 – Attachment A at the terminals of the Elements listed in Section 4.2, Facilities.
    - 4.1.2 Planning Coordinator.
    - 4.1.3 Transmission Owner that applies load-responsive protective relays as described in PRC-026-1 – Attachment A at the terminals of the Elements listed in Section 4.2, Facilities.
  - 4.2. **Facilities:** The following Elements that are part of the Bulk Electric System (BES) ~~Elements~~:
    - 4.2.1 Generators.
    - 4.2.2 Transformers.
    - 4.2.3 Transmission lines.

## 5. Background:

This is the third phase of a three-phased standard development project that focused on developing this new Reliability Standard to address protective relay operations due to stable power swings. The March 18, 2010, Federal Energy Regulatory Commission (FERC) Order No. 733, approved Reliability Standard PRC-023-1 – Transmission Relay Loadability. In this Order, FERC directed NERC to address three areas of relay loadability that include modifications to the approved PRC-023-1, development of a new Reliability Standard to address generator protective relay loadability, and a new Reliability Standard to address the operation of protective relays due to stable power swings. This project's SAR addresses these directives with a three-phased approach to standard development.

Phase 1 focused on making the specific modifications to PRC-023-1 and was completed in the approved Reliability Standard PRC-023-2, which became mandatory on July 1, 2012.

Phase 2 focused on developing a new Reliability Standard, PRC-025-1 – Generator Relay Loadability, to address generator protective relay loadability; PRC-025-1 ~~was approved by FERC~~ became mandatory on July 17 October 1, 2014 along with PRC-023-3, which was modified to harmonize PRC-023-2 with PRC-025-1.

~~This~~ Phase 3 of the project establishes ~~requirements~~Requirements aimed at preventing protective relays from tripping unnecessarily due to stable power swings by requiring the identification of Elements on which a stable or unstable power swing may affect Protection System operation, and to develop ~~requirements~~Requirements to assess the security of load-responsive protective relays to tripping in response to only a stable power swing. Last, to require entities to implement Corrective Action Plans, (CAP), where necessary, to improve ~~security of~~ security of load-responsive protective relays for stable power swings so they are expected to not trip in response to stable power swings during non-Fault conditions, while maintaining dependable fault detection and dependable out-of-step tripping.

**6. Effective DateDates:**

**Requirements R1-R3, R5, and R6**

**Requirement R1**

First day of the first full calendar year that is 12 months after the date that the standard is approved by an applicable governmental authority or as otherwise provided for in a jurisdiction where approval by an applicable governmental authority is required for a standard to go into effect. Where approval by an applicable governmental authority is not required, the standard shall become effective on the first day of the first full calendar year that is 12 months after the date the standard is adopted by the NERC Board of Trustees or as otherwise provided for in that jurisdiction.

**RequirementRequirements R2, R3, and R4**

First day of the first full calendar year that is 36 months after the date that the standard is approved by an applicable governmental authority or as otherwise provided for in a jurisdiction where approval by an applicable governmental authority is required for a standard to go into effect. Where approval by an applicable governmental authority is not required, the standard shall become effective on the first day of the first full calendar year that is 36 months after the date the standard is adopted by the NERC Board of Trustees or as otherwise provided for in that jurisdiction.

## B. Requirements and Measures

**R1.** Each Planning Coordinator shall, at least once each calendar year, ~~identify~~ provide notification of each generator, transformer, and transmission line BES Element in its area that ~~meets~~ meet one or more of the following criteria ~~and provide notification, if any,~~ to the respective Generator Owner and Transmission Owner, if any: [*Violation Risk Factor: Medium*] [*Time Horizon: Long-term Planning*]

Criteria:

1. Generator(s) where an angular stability constraint exists that is addressed by ~~an operating limit~~ a System Operating Limit (SOL) or a Remedial Action Scheme (RAS) and those Elements terminating at the ~~transmission switching~~ Transmission station associated with the generator(s).
  2. An Element that is monitored as part of a ~~System Operating Limit (SOL) that has been established~~ identified by the Planning Coordinator's methodology<sup>1</sup> based on an angular stability ~~constraints identified in system planning or operating studies~~ constraint.
  3. An Element that forms the boundary of an island ~~due to angular instability~~ within the most recent underfrequency load shedding (UFLS) design assessment based on application of the Planning Coordinator's criteria for identifying islands, where the island is formed by tripping the Element due to angular instability.
  4. An Element identified in the most recent annual Planning Assessment where relay tripping occurs due to a stable or unstable power swing during a simulated disturbance.
  - ~~5. An Element reported by the Generator Owner or Transmission Owner pursuant to Requirement R2 or Requirement R3, unless the Planning Coordinator determines the Element is no longer susceptible to power swings.~~
- M1.** Each Planning Coordinator shall have dated evidence that demonstrates ~~identification and the respective~~ notification of the generator, transformer, and transmission line BES Element(s), ~~if any, which~~ that meet one or more of the criteria in Requirement R1, ~~if any, to the respective Generator Owner and Transmission Owner~~ Evidence may include, but is not limited to, the following documentation: emails, facsimiles, records, reports, transmittals, lists, or spreadsheets.

---

<sup>1</sup> NERC Reliability Standard FAC-10 – System Operating Limits Methodology for the Planning Horizon

**Rationale for R1:** The Planning Coordinator has a wide-area view and is in the position to identify generator, transformer, and transmission line BES Elements which meet the criteria, if any. The ~~eriterion~~criteria-based approach is consistent with the NERC System Protection and Control Subcommittee (SPCS) technical document *Protection System Response to Power Swings*, August 2013 (“PSRPS Report”),<sup>2</sup> which recommends a focused approach to determine an at-risk Element.BES Element. See the Guidelines and Technical Basis for a detailed discussion of the criteria.

~~**R1.** Each Transmission Owner shall, within 30 calendar days of identifying an Element that meets either of the following criteria, provide notification of the Element to its Planning Coordinator: *[Violation Risk Factor: Medium] [Time Horizon: Long term Planning]*~~

~~Criteria:~~

- ~~1. An Element that trips due to a stable or unstable power swing during an actual system Disturbance due to the operation of its load responsive protective relays.~~
- ~~2. An Element that forms the boundary of an island during an actual system Disturbance due to the operation of its load responsive protective relays.~~

~~**M2.** Each Transmission Owner shall have dated evidence that demonstrates identification of the Element(s), if any, which meet either of the criteria in Requirement R2. Evidence may include, but is not limited to, the following documentation: emails, facsimiles, records, reports, transmittals, lists, or spreadsheets.~~

~~**Rationale for R2:** The Transmission Owner is in the position to identify the load responsive protective relays that have tripped due to power swings, if any. The criteria is consistent with the PSRPS Report. A time to complete a review of the relay tripping is not addressed here as other NERC Reliability Standards address the review of Protection System operations.~~

~~**R2.** Each Generator Owner shall, within 30 calendar days of identifying an Element that meets the following criterion, provide notification of the Element to its Planning Coordinator: *[Violation Risk Factor: Medium] [Time Horizon: Long term Planning]*~~

~~Criterion:~~

- ~~1. An Element that trips due to a stable or unstable power swing during an actual system Disturbance due to the operation of its load responsive protective relays.~~

---

<sup>2</sup> NERC System Protection and Control Subcommittee, *Protection System Response to Power Swings*, August 2013: [http://www.nerc.com/comm/PC/System%20Protection%20and%20Control%20Subcommittee%20SPCS%2020/SPCS%20Power%20Swing%20Report\\_Final\\_20131015.pdf](http://www.nerc.com/comm/PC/System%20Protection%20and%20Control%20Subcommittee%20SPCS%2020/SPCS%20Power%20Swing%20Report_Final_20131015.pdf)

~~M3.~~ Each Generator Owner shall have dated evidence that demonstrates identification of the Element(s), if any, which the criterion in Requirement R3. Evidence may include, but is not limited to, the following documentation: emails, facsimiles, records, reports, transmittals, lists, or spreadsheets.

~~**Rationale for R3:** The Generator Owner is in the position to identify the load-responsive protective relays that have tripped due to power swings, if any. The criterion is consistent with the PSRPS Report. A requirement or time to complete a review of the relay tripping is not addressed here as other NERC Reliability Standards address the review of Protection System operations.~~

R2. Each Generator Owner and Transmission Owner shall, ~~within~~ determine: [Violation Risk Factor: High] [Time Horizon: Operations Planning]

1.12.1 ~~Within~~ 12 full calendar months of ~~receiving~~ notification of ~~an~~ a BES Element pursuant to Requirement R1 ~~or within 12 full calendar months of identifying an, determine whether its load-responsive protective relay(s) applied to that BES Element pursuant to Requirement R2 or R3, evaluate each identified~~ meets the criteria in PRC-026-1 – Attachment B where an evaluation of that Element’s load-responsive protective relay(s) based on the PRC-026-1 – Attachment B Criteria where the evaluation criteria has not been performed in the last ~~three~~ five calendar years. ~~[Violation Risk Factor: High] [Time Horizon: Operations Planning]~~

2.2 Within 12 full calendar months of becoming aware of a generator, transformer, or transmission line BES Element that tripped in response to a stable or unstable power swing due to the operation of its protective relay(s), determine whether its load-responsive protective relay(s) applied to that BES Element meets the criteria in PRC-026-1 – Attachment B.

~~M4.~~M2. Each Generator Owner and Transmission Owner shall have dated evidence that demonstrates the evaluation was performed according to Requirement ~~R4~~R2. Evidence may include, but is not limited to, the following documentation: apparent impedance characteristic plots, email, design drawings, facsimiles, R-X plots, software output, records, reports, transmittals, lists, settings sheets, or spreadsheets.



**Rationale for R4:** Performing the evaluation in Requirement R4 is the first step in ensuring that the reliability goal of this standard will be met. The PRC-026-1 — Attachment B, Criteria provides a basis for determining if the relays are expected to not trip for a stable power swing. See the Guidelines and Technical Basis for a detailed explanation of the evaluation. **Rationale for R2:** The Generator Owner and Transmission Owner are in a position to determine whether its load-responsive protective relays meet the PRC-026-1 – Attachment B criteria. Generator, transformer, and transmission line BES Elements are identified by the Planning Coordinator in Requirement R1 and by the Generator Owner and Transmission Owner following an actual event where the Generator Owner and Transmission Owner became aware (i.e., through an event analysis or Protection System review) tripping was due to stable or unstable power swing. A period of 12 calendar months allows sufficient time for protection staff to conduct the evaluation.

**R3.** Each Generator Owner and Transmission Owner shall, within ~~60~~six full calendar ~~days~~months of ~~an evaluation that identifies determining a~~ load-responsive protective relays that ~~do~~relays does not meet the PRC-026-1 – Attachment B ~~Criteria pursuant to Requirement R4~~criteria, develop a Corrective Action Plan (CAP) to ~~modify~~meet one or more of the following [*Violation Risk Factor: Medium*] [*Time Horizon: Operations Planning*]

- ~~The~~ Protection System ~~to meet~~meets the PRC-026-1 – Attachment B ~~Criteria~~criteria, while maintaining dependable fault detection and dependable out-of-step tripping (if out-of-step tripping is applied at the terminal of the ~~Element~~); [*Violation Risk Factor: Medium*] [*Time Horizon: Operations Planning*]BES Element); or
- ~~The~~ Protection System is excluded under the PRC-026-1 – Attachment A criteria (e.g., modifying the Protection System so that relay functions are supervised by power swing blocking or using relay systems that are immune to power swings), while maintaining dependable fault detection and dependable out-of-step tripping (if out-of-step tripping is applied at the terminal of the BES Element).

**M5.M3.** The Generator Owner and Transmission Owner shall have dated evidence that demonstrates the development of a CAP in accordance with Requirement **R5R3**. Evidence may include, but is not limited to, the following documentation: corrective action plans, maintenance records, settings sheets, project or work management program records, or work orders.

**Rationale for R5R3:** To meet the reliability purpose of the standard, a CAP is necessary to ~~modify~~ensure the entity’s Protection System ~~to meet~~meets the PRC-026-1 – Attachment B ~~criteria~~ so that protective relays are expected to not trip in response to stable power swings. The phrase, ““...while maintaining dependable fault detection and dependable out-of-step tripping”...” in Requirement **R5R2** describes that the entity is to comply with this standard, while achieving their desired protection goals. Refer to the Guidelines and Technical Basis, Introduction, for more information.

**R2.R4.** Each Generator Owner and Transmission Owner shall implement each CAP developed pursuant to Requirement **R5.R3** and update each CAP if actions or timetables change until all actions are complete. *[Violation Risk Factor: Medium][Time Horizon: Long-Term Planning]*

**M6.M4.** The Generator Owner and Transmission Owner shall have dated evidence that demonstrates implementation of each CAP according to Requirement **R6R4**, including updates to the CAP when actions or timetables change. Evidence may include, but is not limited to, the following documentation: corrective action plans, maintenance records, settings sheets, project or work management program records, or work orders.

**Rationale for R6R4:** Implementation of the CAP must accomplish all identified actions to be complete to achieve the desired reliability goal. During the course of implementing a CAP, updates may be necessary for a variety of reasons such as new information, scheduling conflicts, or resource issues. Documenting CAP changes and completion of activities provides measurable progress and confirmation of completion.

## C. Compliance

### 1. Compliance Monitoring Process

#### 1.1. Compliance Enforcement Authority

As defined in the NERC Rules of Procedure, “Compliance Enforcement Authority” (CEA) means NERC or the Regional Entity in their respective roles of monitoring and enforcing compliance with the NERC Reliability Standards.

#### 1.2. Evidence Retention

The following evidence retention periods identify the period of time an entity is required to retain specific evidence to demonstrate compliance. For instances where the evidence retention period specified below is shorter than the time since the last audit, the CEA may ask an entity to provide other evidence to show that it was compliant for the full time period since the last audit.

The Generator Owner, Planning Coordinator, and Transmission Owner shall keep data or evidence to show compliance as identified below unless directed by its CEA to retain specific evidence for a longer period of time as part of an investigation.

- The Planning Coordinator shall retain evidence of Requirement R1 for a minimum of ~~three~~one calendar ~~years~~year following the completion of ~~each~~the Requirement.
- ~~The Transmission Owner shall retain evidence of Requirement R2 for a minimum of three calendar years following the completion of each Requirement.~~

- ~~• The Generator Owner shall retain evidence of Requirement R3 for a minimum of three calendar years following the completion of each Requirement.~~
- The Generator Owner and Transmission Owner shall retain evidence of Requirement ~~R4~~R2 evaluation for a minimum of ~~36~~12 calendar months following completion of each evaluation where a CAP is not developed.
- The Generator Owner and Transmission Owner shall retain evidence of Requirements ~~R5 and R6, including any supporting analysis per Requirements R1, R2, R3, and R4,~~ for a minimum of 12 calendar months following completion of each CAP.

If a Generator Owner, Planning Coordinator, or Transmission Owner is found non-compliant, it shall keep information related to the non-compliance until mitigation is complete and approved, or for the time specified above, whichever is longer.

The CEA shall keep the last audit records and all requested and submitted subsequent audit records.

### 1.3. Compliance Monitoring and Assessment Processes:

~~Compliance Audit~~

~~Self-Certification~~

~~Spot-Checking~~

~~Compliance Violation Investigation~~

~~Self-Reporting~~

~~Complaint~~

As defined in the NERC Rules of Procedure; “Compliance Monitoring and Assessment Processes” refers to the identification of the processes that will be used to evaluate data or information for the purpose of assessing performance or outcomes with the associated reliability standard.

### 1.4. Additional Compliance Information

None.

Table of Compliance Elements

R#	Time Horizon	VRF	Violation Severity Levels			
			Lower VSL	Moderate VSL	High VSL	Severe VSL
R1	Long-term Planning	Medium	The Planning Coordinator <del>identified an Element and</del> provided notification <u>of the BES Element(s)</u> in accordance with Requirement R1, but was less than or equal to 30 calendar days late.	The Planning Coordinator <del>identified an Element and</del> provided notification <u>of the BES Element(s)</u> in accordance with Requirement R1, but was more than 30 calendar days and less than or equal to 60 calendar days late.	The Planning Coordinator <del>identified an Element and</del> provided notification <u>of the BES Element(s)</u> in accordance with Requirement R1, but was more than 60 calendar days and less than or equal to 90 calendar days late.	The Planning Coordinator <del>identified an Element and</del> provided notification <u>of the BES Element(s)</u> in accordance with Requirement R1, but was more than 90 calendar days late.  OR  The Planning Coordinator failed to <del>identify an provide</del> <u>notification of the BES Element(s)</u> in accordance with Requirement R1.  OR  <del>The Planning Coordinator failed to provide notification in accordance with Requirement R1.</del>

R#	Time Horizon	VRF	Violation Severity Levels			
			Lower VSL	Moderate VSL	High VSL	Severe VSL
<del>R2</del>	<del>Long-term Planning</del>	<del>Medium</del>	<del>The Transmission Owner identified an Element and provided notification in accordance with Requirement R2, but was less than or equal to 10 calendar days late.</del>	<del>The Transmission Owner identified an Element and provided notification in accordance with Requirement R2, but was more than 10 calendar days and less than or equal to 20 calendar days late.</del>	<del>The Transmission Owner identified an Element and provided notification in accordance with Requirement R2, but was more than 20 calendar days and less than or equal to 30 calendar days late.</del>	<del>The Transmission Owner identified an Element and provided notification in accordance with Requirement R2, but was more than 30 calendar days late.  OR  The Transmission Owner failed to identify an Element in accordance with Requirement R2.  OR  The Transmission Owner failed to provide notification in accordance with Requirement R2.</del>

R#	Time Horizon	VRF	Violation Severity Levels			
			Lower VSL	Moderate VSL	High VSL	Severe VSL
<del>R3</del>	<del>Long-term Planning</del>	<del>Medium</del>	<del>The Generator Owner identified an Element and provided notification in accordance with Requirement R3, but was less than or equal to 10 calendar days late.</del>	<del>The Generator Owner identified an Element and provided notification in accordance with Requirement R3, but was more than 10 calendar days and less than or equal to 20 calendar days late.</del>	<del>The Generator Owner identified an Element and provided notification in accordance with Requirement R3, but was more than 20 calendar days and less than or equal to 30 calendar days late.</del>	<del>The Generator Owner identified an Element and provided notification in accordance with Requirement R3, but was more than 30 calendar days late.</del> <del>OR</del> <del>The Generator Owner failed to identify an Element in accordance with Requirement R3.</del> <del>OR</del> <del>The Generator Owner failed to provide notification in accordance with Requirement R3.</del>

R#	Time Horizon	VRF	Violation Severity Levels			
			Lower VSL	Moderate VSL	High VSL	Severe VSL
<b><u>R4R2</u></b>	Operations Planning	High	The Generator Owner or Transmission Owner evaluated <del>each identified</del> <u>Element's</u> load-responsive protective relay(s) in accordance with Requirement <b><u>R4R2</u></b> , but was less than or equal to 30 calendar days late.	The Generator Owner or Transmission Owner evaluated <del>each identified</del> <u>Element's</u> load-responsive protective relay(s) in accordance with Requirement <b><u>R4R2</u></b> , but was more than 30 calendar days and less than or equal to 60 calendar days late.	The Generator Owner or Transmission Owner evaluated <del>each identified</del> <u>Element's</u> load-responsive protective relay(s) in accordance with Requirement <b><u>R4R2</u></b> , but was more than 60 calendar days and less than or equal to 90 calendar days late.	The Generator Owner or Transmission Owner evaluated <del>each identified</del> <u>Element's</u> load-responsive protective relay(s) in accordance with Requirement <b><u>R4R2</u></b> , but was more than 90 calendar days late. OR The Generator Owner or Transmission Owner failed to evaluate <del>each identified</del> <u>Element's</u> load-responsive protective relay(s) in accordance with Requirement <b><u>R4R2</u></b> .

R#	Time Horizon	VRF	Violation Severity Levels			
			Lower VSL	Moderate VSL	High VSL	Severe VSL
<del>R5R3</del>	Long-term Planning	Medium	The Generator Owner or Transmission Owner developed a <u>Corrective Action Plan (CAP)</u> in accordance with Requirement <del>R5R3</del> , but in more than <del>60six</del> calendar <del>daysmonths</del> and less than or equal to <del>70seven</del> calendar <del>daysmonths</del> .	The Generator Owner or Transmission Owner developed a <u>Corrective Action Plan (CAP)</u> in accordance with Requirement <del>R5R3</del> , but in more than <del>70seven</del> calendar <del>daysmonths</del> and less than or equal to <del>80eight</del> calendar <del>daysmonths</del> .	The Generator Owner or Transmission Owner developed a <u>Corrective Action Plan (CAP)</u> in accordance with Requirement <del>R5R3</del> , but in more than <del>80eight</del> calendar <del>daysmonths</del> and less than or equal to <del>90nine</del> calendar <del>daysmonths</del> .	The Generator Owner or Transmission Owner developed a <u>Corrective Action Plan (CAP)</u> in accordance with Requirement <del>R5R3</del> , but in more than <del>90nine</del> calendar <del>daysmonths</del> .  OR The Generator Owner or Transmission Owner failed to develop a CAP in accordance with Requirement <del>R5R3</del> .
<del>R6R4</del>	Long-term Planning	Medium	The Generator Owner or Transmission Owner implemented <del>a</del> <u>Corrective Action Plan (CAP)</u> , but failed to update a CAP; when actions or timetables changed, in accordance with Requirement <del>R6R4</del> .	N/A	N/A	The Generator Owner or Transmission Owner failed to implement a <u>Corrective Action Plan (CAP)</u> in accordance with Requirement <del>R6R4</del> .



#### D. Regional Variances

None.

#### E. Interpretations

None.

#### F. Associated Documents

*Applied Protective Relaying*, Westinghouse Electric Corporation, 1979.

Burdy, John, *Loss-of-excitation Protection for Synchronous Generators GER-3183*, General Electric Company.

IEEE Power System Relaying Committee WG D6, *Power Swing and Out-of-Step Considerations on Transmission Lines*, July 2005: <http://www.pes-psrc.org/Reports/Power%20Swing%20and%20OOS%20Considerations%20on%20Transmission%20Lines%20F..pdf>.

Kimbark Edward Wilson, *Power System Stability, Volume II: Power Circuit Breakers and Protective Relays*, Published by John Wiley and Sons, 1950.

~~Kundar~~ Kundur, Prabha, *Power System Stability and Control*, 1994, Palo Alto: EPRI, McGraw Hill, Inc.

NERC System Protection and Control Subcommittee, *Protection System Response to Power Swings*, August 2013: [http://www.nerc.com/comm/PC/System%20Protection%20and%20Control%20Subcommittee%20SPCS%2020/SPCS%20Power%20Swing%20Report\\_Final\\_20131015.pdf](http://www.nerc.com/comm/PC/System%20Protection%20and%20Control%20Subcommittee%20SPCS%2020/SPCS%20Power%20Swing%20Report_Final_20131015.pdf).

Reimert, Donald, *Protective Relaying for Power Generation Systems*, 2006, Boca Raton: CRC Press.

### PRC-026-1 – Attachment A

This standard ~~includes~~applies to any protective functions which could trip instantaneously or with a time delay of less than 15 cycles, on load current (i.e., “load-responsive”) including, but not limited to:

- Phase distance
- Phase overcurrent
- Out-of-step tripping
- Loss-of-field

The following protection functions are excluded from ~~requirements~~Requirements of this standard:

- Relay elements supervised by power swing blocking
- Relay elements that are only enabled when other relays or associated systems fail. For example:
  - Overcurrent elements that are only enabled during loss of potential conditions.
  - ~~Elements~~Relay elements that are only enabled during a loss of communications
- Thermal emulation relays which are used in conjunction with dynamic Facility Ratings
- Relay elements associated with direct current (dc) lines
- Relay elements associated with dc converter transformers
- Phase fault detector relay elements employed to supervise other load-responsive phase distance elements (e.g., in order to prevent false operation in the event of a loss of potential) provided the distance element is set in accordance with the criteria outlined in the standard
- Relay elements associated with switch-onto-fault schemes
- Reverse power relay on the generator
- Generator relay elements that are armed only when the generator is disconnected from the system, (e.g., non-directional overcurrent elements used in conjunction with inadvertent energization schemes, and open breaker flashover schemes)
- Current differential relay, pilot wire relay, and phase comparison relay
- Voltage-restrained or voltage-controlled overcurrent relays

PRC-026-1 – Attachment B

Criteria A:

An impedance-based relay ~~characteristic~~, used for tripping, ~~that is expected to not trip for a stable power swing, when the relay characteristic~~ is completely contained within the ~~portion of the lens characteristic~~unstable power swing region.<sup>3</sup> The unstable power swing region is formed ~~by the union of three shapes~~ in the impedance (R-X) plane; (1) a lower loss-of-synchronism circle based on a ratio of the sending-end to receiving-end voltages of 0.7; (2) an upper loss-of-synchronism circle based on a ratio of the receiving-end to sending-end voltages of 1.43; (3) a lens that connects the endpoints of the total system impedance (with the parallel transfer impedance removed) bounded by varying the sending-end and receiving-end voltages from 0.70 to 1.0 per unit, while maintaining a constant system separation angle across the total system impedance where:

1. The system separation angle is:
  - At least 120 degrees, or
  - An angle less than 120 degrees where a documented transient stability analysis demonstrates that the expected maximum stable separation angle is less than 120 degrees.
2. All generation is in service and all transmission BES Elements are in their normal operating state when calculating the system impedance.
3. Saturated (transient or sub-transient) reactance is used for all machines.

**Rationale for Attachment B (Criteria A):** The PRC-026-1, Attachment B, Criteria A provides a basis for determining if the relays are expected to not trip for a stable power swing having a system separation angle of up to 120 degrees with the sending-end and receiving-end voltages varying from 0.7 to 1.0 per unit (See Guidelines and Technical Basis).

<sup>3</sup> Guidelines and Technical Basis, Figures 1 and 2.

**PRC-026-1 – Attachment B**

Criteria B:

The pickup of an overcurrent relay element used for tripping, that is above the calculated current value (with the parallel transfer impedance removed) for the conditions below:

1. The system separation angle is:
  - At least 120 degrees, or
  - An angle less than 120 degrees where a documented transient stability analysis demonstrates that the expected maximum stable separation angle is less than 120 degrees.
2. All generation is in service and all transmission BES Elements are in their normal operating state when calculating the system impedance.
3. Saturated (transient or sub-transient) reactance is used for all machines.
4. Both the sending-end and receiving-end voltages at 1.05 per unit.

**Rationale for Attachment B (Criteria B):** The PRC-026-1, Attachment B, Criteria B provides a basis for determining if the relays are expected to not trip for a stable power swing having a system separation angle of up to 120 degrees with the sending-end and receiving-end voltages at 1.05 per unit (See Guidelines and Technical Basis).



## **Guidelines and Technical Basis**

### **Introduction**

The NERC System Protection and Control Subcommittee technical document, *Protection System Response to Power Swings*, August 2013<sup>4</sup> (“PSRPS Report” or “report”) was specifically prepared to support the development of this NERC Reliability Standard. The report provided a historical perspective on power swings as early as 1965 up through the approval of the report by the NERC Planning Committee. The report also addresses reliability issues regarding trade-offs between security and dependability of ~~protection systems~~Protection Systems, considerations for this NERC Reliability Standard, and a collection of technical information about power swing characteristics and varying issues with practical applications and approaches to power swings. Of these topics, the report suggests an approach for this NERC Reliability Standard (“standard” or “PRC-026-1”) which is consistent with addressing two of the three regulatory directives in the FERC Order No. 733. The first directive concerns the need for “...protective relay systems that differentiate between faults and stable power swings and, when necessary, phases out protective relay systems that cannot meet this requirement.”<sup>5</sup> Second, is “...to develop a Reliability Standard addressing undesirable relay operation due to stable power swings.”<sup>6</sup> The third directive “...to consider “islanding” strategies that achieve the fundamental performance for all islands in developing the new Reliability Standard addressing stable power swings”<sup>7</sup> was considered during development of the standard.

The development of this standard implements the majority of the ~~approach~~approaches suggested by the report. However, it is noted that the Reliability Coordinator and Transmission Planner have not been included in the standard’s Applicability section (as suggested by the PSRPS Report). This is so that a single entity, the Planning Coordinator, may be the single source for identifying Elements according to Requirement R1. A single source will insure that multiple entities will not identify Elements in duplicate, nor will one entity fail to provide an Element because it believes the Element is being provided by another entity. The Planning Coordinator has, or has access to, the wide-area model and can correctly identify the Elements that may be susceptible to a stable ~~power swing~~unstable power swing. Additionally, not including the Reliability Coordinator and Transmission Planner is consistent with the applicability of other relay loadability NERC Reliability Standards (e.g., PRC-023 and PRC-025). It is also consistent with the NERC Functional Model.

The phrase, “while maintaining dependable fault detection and dependable out-of-step tripping” in Requirement ~~R1R2~~R2, describes that the Generator Owner and Transmission Owner is to comply with this standard, while achieving its desired protection goals. Load-responsive protective relays,

---

<sup>4</sup> NERC System Protection and Control Subcommittee, *Protection System Response to Power Swings*, August 2013: [http://www.nerc.com/comm/PC/System%20Protection%20and%20Control%20Subcommittee%20SPCS%20/SPCS%20Power%20Swing%20Report\\_Final\\_20131015.pdf](http://www.nerc.com/comm/PC/System%20Protection%20and%20Control%20Subcommittee%20SPCS%20/SPCS%20Power%20Swing%20Report_Final_20131015.pdf)

<sup>5</sup> Transmission Relay Loadability Reliability Standard, Order No. 733, P.150 FERC ¶ 61,221 (2010).

<sup>6</sup> Ibid. P.153.

<sup>7</sup> Ibid. P.162.

as addressed within this standard, may be intended to provide a variety of backup protection functions, both within the generating unit or generating plant and on the ~~Transmission~~transmission system, and this standard is not intended to result in the loss of these protection functions. Instead, it is suggested that the Generator Owner and Transmission Owner consider both the ~~requirements~~Requirements within this standard and its desired protection goals, and perform modifications to its protective relays or protection philosophies as necessary to achieve both.

### Power Swings

The IEEE Power System Relaying Committee WG D6 developed a technical document called *Power Swing and Out-of-Step Considerations on Transmission Lines* (July 2005) that provides background on power swings. The following are general definitions from that document:<sup>8</sup>

**Power Swing:** a variation in three phase power flow which occurs when the generator rotor angles are advancing or retarding relative to each other in response to changes in load magnitude and direction, line switching, loss of generation, faults, and other system disturbances.

**Pole Slip:** a condition whereby a generator, or group of generators, terminal voltage angles (or phases) go past 180 degrees with respect to the rest of the connected power system.

**Stable Power Swing:** a power swing is considered stable if the generators do not slip poles and the system reaches a new state of equilibrium, i.e. an acceptable operating condition.

**Unstable Power Swing:** a power swing that will result in a generator or group of generators experiencing pole slipping for which some corrective action must be taken.

**Out-of-Step Condition:** Same as an unstable power swing.

**Electrical System Center or Voltage Zero:** it is the point or points in the system where the voltage becomes zero during an unstable power swing.

### Burden to Entities

The PSRPS Report provides a technical basis and approach for focusing on Protection Systems, which are susceptible to power swings, while achieving the ~~reliability objective purpose of the standard~~. The approach reduces the number of relays ~~that to which~~ the PRC-026-1 Requirements would apply ~~to~~ by first identifying the ~~Bulk Electric System (BES)~~ Element(s) ~~that need to on~~ which load-responsive protective relays must be evaluated. The first step uses criteria to identify ~~a BES Element~~the Elements on which a Protection System is expected to be challenged by power swings. Of those ~~BES~~ Elements, the second step is to evaluate each load-responsive protective relay that is applied on each identified Element. Rather than requiring the Planning Coordinator or Transmission Planner to perform simulations to obtain information for each identified Element, the Generator Owner and Transmission Owner will reduce the need for simulation by comparing

---

<sup>8</sup> <http://www.pes-psrc.org/Reports/Power%20Swing%20and%20OOS%20Considerations%20on%20Transmission%20Lines%20F..pdf>.

the load-responsive protective relay characteristic to specific criteria ~~found~~ in PRC-026-1 – Attachment B.

### Applicability

The standard is applicable to the Generator Owner, Planning Coordinator, and Transmission Owner entities. More specifically, the Generator Owner and Transmission Owner entities are applicable when applying load-responsive protective relays at the terminals of the applicable BES Elements. ~~All the entities have a responsibility to identify the Elements which meet specific criteria.~~ The standard is applicable to the following BES Elements: generators, ~~transformers, and transmission lines,~~ transformers, and transmission lines. The Distribution Provider was considered for inclusion in the standard; however, it is not subject to the standard because this entity, by functional registration, would not own generators, transmission lines, or transformers other than load serving.

Load-responsive protective relays include any protective functions which could trip with or without time delay, on load current.

### Requirement R1

The Planning Coordinator has a wide-area view and is in the position to identify what, if any, Elements meet the criteria. The criterion-based approach is consistent with the NERC System Protection and Control Subcommittee (SPCS) technical document *Protection System Response to Power Swings* (August 2013),<sup>9</sup> which recommends a focused approach to determine an at-risk Element. Identification of Elements comes from the annual Planning Assessments pursuant to the transmission planning (i.e., “TPL”) and other NERC Reliability Standards, ~~(e.g., PRC-006),~~ and the standard is not requiring any other assessments to be performed by the Planning Coordinator. The required ~~annual~~ notification on a calendar year basis to the respective Generator Owner and Transmission Owner is sufficient because it is expected that the Planning Coordinator will make its notifications following the completion of its annual Planning Assessments. The Planning Coordinator will continue to provide notification of Elements on a calendar year basis even if a study is performed less frequently (e.g., PRC-006 – Automatic Underfrequency Load Shedding, which is five years) and has not changed. It is possible that the Planning Coordinator provided notification of Elements in two different calendar years using the same annual Planning Assessment.

### Criterion 1

The first criterion involves generator(s) where an angular stability constraint exists ~~which~~ that is addressed by ~~an operating limit~~ System Operating Limit (SOL) or a Remedial Action Scheme (RAS) and those Elements terminating at the ~~transmission switching~~ Transmission station associated with the generator(s). For example, a scheme to remove generation for specific conditions is implemented for a four-unit generating plant (1,100 MW). Two of the units are 500

---

<sup>9</sup> [http://www.nerc.com/comm/PC/System%20Protection%20and%20Control%20Subcommittee%20SPCS%2020/SPCS%20Power%20Swing%20Report\\_Final\\_20131015.pdf](http://www.nerc.com/comm/PC/System%20Protection%20and%20Control%20Subcommittee%20SPCS%2020/SPCS%20Power%20Swing%20Report_Final_20131015.pdf)



## PRC-026-1 – Application Guidelines

---

MW each; one is connected to the 345 kV system and one is connected to the 230 kV system. The Transmission Owner has two 230 kV transmission lines and one 345 kV transmission line all terminating at the generating facility as well as a 345/230 kV autotransformer. The remaining 100 MW consists of two 50 MW combustion turbine (CT) units connected to four 66 kV transmission lines. The 66 kV transmission line is not electrically joined to the 345 kV and 230 kV transmission lines at the plant site and is not a part of the operating limit or RAS. A stability constraint limits the output of the portion of the plant affected by the RAS to 700 MW for an outage of the 345 kV transmission line. The RAS trips one of the 500 MW units to maintain stability for a loss of the 345 kV transmission line when the total output from both 500 MW units is above 700 MW. For this example, both 500 MW generating units and the associated generator step-up (GSU) transformers would be identified as Elements meeting this criterion. The 345/230 kV autotransformer, the 345 kV transmission line, and the two 230 kV transmission lines would also be identified as Elements meeting this criterion. The 50 MW combustion turbines and 66 kV transmission lines would not be identified pursuant to Criterion 1 because these Elements are not subject to an operating limit or RAS and do not terminate at the ~~transmission switching~~Transmission station associated with the generators that are subject to the ~~operating limit and SOL~~ or RAS.

### Criterion 2

The second criterion involves Elements that are monitored ~~due to~~ as a part of an established System Operating Limit (SOL) based on an angular stability limit regardless of the outage conditions that result in the enforcement of the SOL. For example, if two long parallel 500 kV transmission lines have a combined SOL of 1,200 MW, and this limit is based on angular instability resulting from a fault and subsequent loss of one of the two lines, then both lines would be identified as an Element meeting the criterion.

### Criterion 3

The third criterion involves ~~the Element~~Elements that ~~forms~~form the boundary of an island ~~due to angular instability~~ within an underfrequency load shedding (UFLS) design assessment. ~~While the island may form due to various transmission lines tripping for a combination of reasons, such as stable and unstable power swings, faults, and excessive loading, the~~ The criterion requires that all lines that tripped in simulation due to “angular instability” to form the island be applies to islands identified as meeting the based on application of the Planning Coordinator’s criteria for identifying islands, where the island is formed by tripping the Elements based on angular instability. The criterion applies if the angular instability is modeled in the UFLS design assessment, or if the boundary is identified “off-line” (i.e., the Elements are selected based on angular instability considerations, but the Elements are tripped in the UFLS design assessment without modeling the initiating angular instability). In cases where an out-of-step condition is detected and tripping is initiated at an alternate location, the criterion applies to the Element on which the power swing is detected. The criterion does not apply to islands identified based on other considerations that do not involve angular instability, such as excessive loading.

### **Criterion 4**

The fourth criterion involves Elements identified in the most recent annual Planning Assessment where relay tripping occurs due to a stable or unstable power swing during a simulated disturbance. The intent is for the Planning Coordinator to include any Element(s) where relay tripping was observed during simulations performed for the most recent annual Planning Assessment associated with the transmission planning TPL-001-4 Reliability Standard. Note that relay tripping must be assessed within those annual Planning Assessments per TPL-001-4, R4, Part 4.3.1.3, which indicates that analysis shall include the “Tripping of Transmission lines and transformers where transient swings cause Protection System operation based on generic or actual relay models.” Identifying such Elements according to ~~eriterion~~Criterion 4 and notifying the respective Generator Owner and Transmission Owner will require that the owners of any load-responsive protective relay applied at the terminals of the identified Element evaluate the relay’s susceptibility to tripping in response a stable power swing.

Planning Coordinators have discretion to determine whether observed tripping for a power swing in its Planning Assessments occurs for valid contingencies and system conditions. The Planning Coordinator will address tripping that is observed in transient analyses on an individual basis; therefore, the Planning Coordinator is responsible for identifying the Elements based only on simulation results that are determined to be valid.

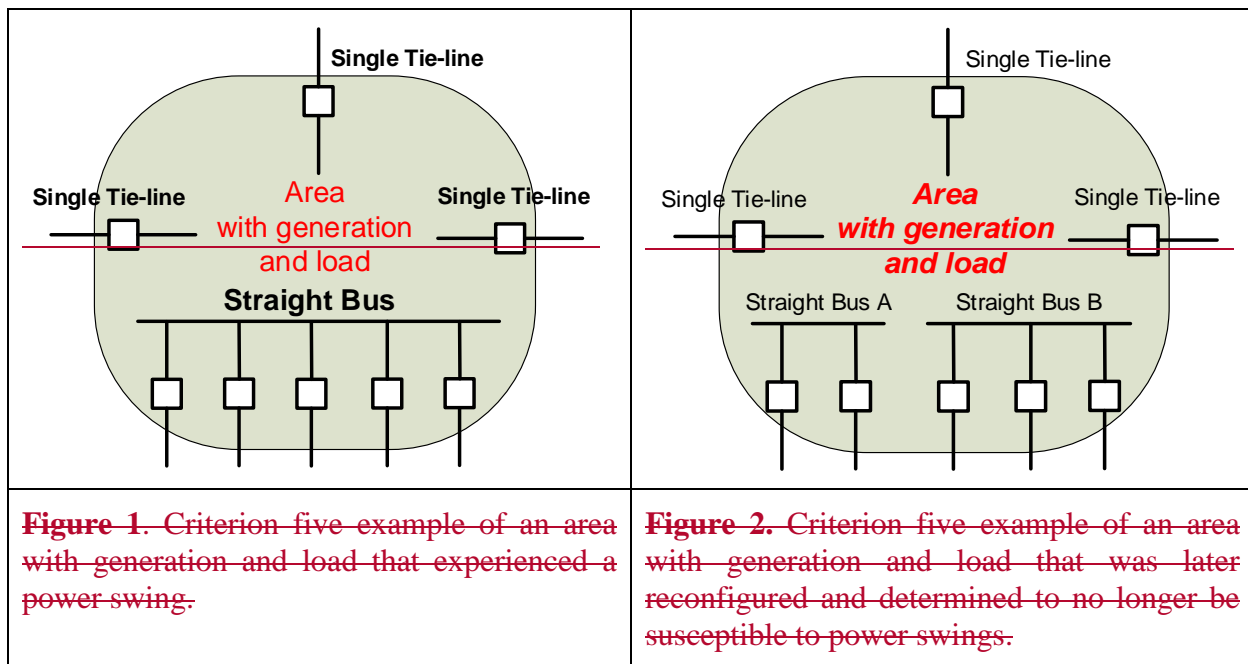
Due to the nature of how a Planning Assessment is performed, there may be cases where a previously-identified Element is not identified in the most recent annual Planning Assessment. If so, this is acceptable because the Generator Owner and Transmission Owner would have taken action upon the initial notification of the previously identified Element. When an Element is not identified in later Planning Assessments, the risk of load-responsive protective relays tripping in response to a stable power swing during non-Fault conditions would have already been assessed under Requirement R4R2 and mitigated according to Requirements R5R3 and R6 ~~when appropriate.~~R4 where the relays did not meet the PRC-026-1 – Attachment B criteria. According to Requirement R4R2, the Generator Owner and Transmission Owner are only required to re-evaluate each load-responsive protective relay for an identified Element where the evaluation has not been performed in the last threefive calendar years.

### **Criterion 5**

~~The fifth criterion involves Elements that have actually tripped due to a stable or unstable power swing as reported by the Generator Owner and Transmission Owner. The Planning Coordinator will continue to identify each reported Element until the Planning Coordinator determines that the Element is expected to not trip in response to power swings due to BES configuration changes. For example, eight lines interconnecting areas containing both generation and load to the rest of the BES, and five of the lines terminate on a single straight bus as shown in Figure 1. A forced outage of the straight bus in the past caused an island to form by tripping open the five lines connecting to the straight bus, and subsequently causing the other three lines into the area to trip on power swings. If the BES is reconfigured such that the five lines into the straight bus are now divided between two different substations, the Planning Coordinator may determine that the changes eliminated susceptibility to power swings as shown in Figure 2. If so, the Planning Coordinator is no longer required to identify these Elements previously reported by either the~~

## PRC-026-1 – Application Guidelines

~~Transmission Owner pursuant to Requirement R2 or Generator Owner pursuant to Requirement R3.~~



Although Requirement R1 requires the Planning Coordinator to notify the respective Generator Owner and Transmission Owner of any Elements meeting ~~the~~ one or more of the ~~five~~four criteria, it does not preclude the Planning Coordinator from providing additional information, such as apparent impedance characteristics, in advance or upon request, that may be useful in evaluating protective relays. Generator Owners and Transmission Owners are able to complete protective relay evaluations and perform the required actions without additional information. The standard does not ~~included~~include any requirement for the entities to provide information that is already being shared or exchanged between entities for operating needs. While a ~~requirement~~Requirement has not been included for the exchange of information, entities ~~must~~should recognize that relay performance needs to be measured against the most current information.

## Requirement R2

~~The approach of Requirement R2 requires the Transmission Owner to identify Elements that meet the focused criteria. Only the Elements that meet the criteria and apply a load responsive protective relay at the terminal of the Element are in scope. Using the criteria focuses the reliability concern on the Element that is at risk to power swings.~~

~~The first criterion involves Elements that have tripped due to a power swing during an actual system Disturbance, regardless of whether the power swing was stable or unstable. Elements that have tripped by unstable power swings are included in this requirement because they were not identified in Requirement R1 and this forms a basis for evaluating the load responsive relay operation for stable power swings. After this standard becomes effective, if it is determined in an~~

~~outage investigation that an Element tripped because of a power swing condition (either stable or unstable), this standard will become applicable to the Element. An example of an identified Element is an Element tripped by a distance relay element (i.e., a relay with a time delay of less than 15 cycles) during a power swing condition. Another example that would identify an Element is where out-of-step (OOS) tripping is applied on the Element, and if a legitimate OOS trip occurred as expected during a power swing event.~~

~~The second criterion involves the formation of an island based on an actual system Disturbance. While the island may form due to several transmission lines tripping for a combination of reasons, such as power swings (stable or unstable), faults, or excessive loading, the criterion requires that all Elements that tripped to form the island be identified as meeting this criterion. For example, the Disturbance may have been initiated by one line faulting with a second line being out of service. The outage of those two lines then initiated a swing condition between the “island” and the rest of the system across the remaining ties causing the remaining ties to open. A second case might be that the island could have formed by a fault on one of the other ties with a line out of service with the swing going across the first and second lines mentioned above resulting in those lines opening due to the swing. Therefore, the inclusion of all the Elements that formed the boundary of the island are included as Elements to be reported to the Planning Coordinator.~~

~~The owner of the load responsive protective relay that tripped for either criterion is required to identify the Element and notify its Planning Coordinator. Notifying the Planning Coordinator of the Element ensures that the planner is aware of an Element that is susceptible to a power swing or formed an island. The Planning Coordinator will continue to notify the respective entities of the identified Element under Requirement R1, Criterion 5 unless the Planning Coordinator determines the Element is no longer susceptible to power swings.~~

### **Requirement R3**

~~Requirement R3 is similar to Requirement R2, Criterion 1 and requires the Generator Owner to identify any Element that trips due to a power swing condition (stable or unstable) in an actual event. This standard does not focus on the review of Protection Systems because they are covered by other NERC Reliability Standards. When a review of the Generator Owner’s Protection System reveals that tripping occurred due to a power swing, it is required to identify the Element and to notify its Planning Coordinator. Notifying the Planning Coordinator of the Element ensures that the planner is aware of an Element that was susceptible to a power swing. The Planning Coordinator will continue to notify entities of the identified Element under Requirement R1 unless the Planning Coordinator determines the Element is no longer susceptible to power swings.~~

### **Requirement R4**

~~Requirement R4~~Requirement R2 requires the Generator Owner and Transmission Owner to evaluate its load-responsive protective relays ~~applied at all of the terminals of an identified Element to ensure that load responsive protective relays they are expected to not trip in response to stable power swings during non-Fault conditions.~~

## **PRC-026-1 – Application Guidelines**

The PRC-026-1 – Attachment A lists the applicable load-responsive relays that must be evaluated. These relays include phase distance, phase overcurrent, out-of-step tripping, and loss-of-field. Phase distance relays can include the following:

- Mho element characteristics such as Zone 1, Zone 2, or Zone 3 with intentional time delays of 15 cycles or less.
- Mho element characteristics that overreach the remote line terminal used in high-speed, communications assisted tripping schemes including:
  - Directional Comparison Blocking (DCB) schemes
  - Directional Comparison Un-Blocking (DCUB) schemes
  - Permissive Overreach Transfer Trip (POTT) schemes

A method is provided within the standard to support consistent evaluation by Generator Owners and Transmission Owners based on specified conditions. Once a Generator Owner or Transmission Owner is notified of Elements pursuant to Requirement R1, ~~or once a Generator Owner or Transmission Owner identifies an Element pursuant to Requirement R2 or R3,~~ it has 12 full calendar months to ~~evaluate~~determine if each Element's load-responsive protective relays ~~based on~~meet the applicable PRC-026-1 – Attachment B, ~~Criteria A and B~~ criteria, if the ~~evaluation has not~~determination has not been performed in the last ~~three~~five calendar years. Additionally, each Generator Owner and Transmission Owner, that becomes aware of a generator, transformer, or transmission line BES Element that tripped in response to a stable or unstable power swing due to the operation of its protective relays, must perform the same PRC-026-1 – Attachment B criteria determination within 12 full calendar months.

### **Becoming Aware of an Element That Tripped in Response to a Power Swing**

Part 2.2 in Requirement R2 is intended to initiate action by the Generator Owner and Transmission Owner when there is a known stable or unstable power swing and it resulted in the entity's Element tripping. The criterion starts with becoming aware of the event (i.e., power swing) and then any connection with the entity's Element tripping. By doing so, the focus is removed from the entity having to demonstrate that it performed a power swing analysis for every Element trip. The basis for structuring the criterion in this manner is driven by the available ways that a Generator Owner and Transmission Owner could become aware of an Element that tripped in response to a stable or unstable power swing due to the operation of its protective relay(s).

Element trips caused by stable or unstable power swings, though infrequent, would be more common in a larger event. The identification of power swings will be revealed during an analysis of the event. Event analysis could include internal analysis conducted by the entity, the entity's Protection System review following a trip, or a larger scale analysis which includes involvement by the entity's Regional Entity and in some cases NERC.

### **Information Common to Both Generation and Transmission Elements**

The PRC-026-1 – Attachment A lists the load-responsive protective relays that are subject to this standard. Generator Owners and Transmission Owners may own load-responsive protective relays (i.e., distance relays) that directly affect generation or transmission BES Elements and will

## PRC-026-1 – Application Guidelines

require analysis as a result of Elements being identified by ~~Requirements R1, R2 or R3.~~ the Planning Coordinator in Requirement R1 or the Generator Owner or Transmission Owner in Requirement R2. For example, distance relays owned by the Transmission Owner may be installed at the high-voltage side of the generator step-up (GSU) transformer (directional toward the generator) providing backup to generation protection. Generator Owners may have distance relays applied ~~for back-up to~~ backup transmission protection or ~~back-up~~ backup protection ~~for~~ to the GSU transformer. The Generator Owner may have relays installed at the generator terminals or the high-voltage side of the GSU transformer.

### **Exclusion of Time Based Load-Responsive Protective Relays**

The purpose of the standard is ~~“To~~ “[t]o ensure that load-responsive protective relays are expected to not trip in response to stable power swings during non-Fault conditions.” Load-responsive ~~protective relays with,~~ high-speed tripping protective relays pose the highest risk of operating during a power swing. Because of this, high-speed tripping ~~is~~ protective relays and relays with a time delay of less than 15 cycles are included in the standard ~~and others (Zone;~~ whereas other relays (i.e., Zones 2 and 3) with a time a delay of 15 cycles or greater are excluded. The time delay used for exclusion on some load-responsive protective relays is recommended based on 1) the minimum time delay these relays are set in practice, and 2) the maximum expected time that load-responsive protective relays would be exposed to ~~the~~ a stable power swing based on a swing rate.

In order to establish a time delay that ~~strikes a line between~~ distinguishes a high-risk load-responsive protective relay ~~and from~~ one that has a time delay for tripping ~~;~~ (lower-risk), a sample of swing rates were calculated based on a stable power swing entering and leaving the impedance characteristic as shown in Table 1. For a relay impedance characteristic that has the power swing entering and leaving beginning at 90 degrees with a termination at 120 degrees before exiting the zone, calculation of the timer must be greater than the time the stable swing is inside the relay operate zone.

E Zone time

q. > 2

$$(1 \times \left( \frac{(120^\circ - \text{Angle of entry into the relay characteristic})}{\text{Slip Rate}} \right) \left( \frac{(120^\circ - \text{Angle of entry into } t}{(360 \times S)} \right)$$

Table 1. Swing Rates	
Zone Timer (Cycles)	Slip Rate (Hz)
10	1.00
15	0.67
20	0.50
30	0.33

With a minimum zone timer of 15 cycles, the corresponding slip of the system is 0.67 Hz. This represents an approximation of a slow slip rate during a system Disturbance. ~~This~~ Consequently, this value corresponds to the typical minimum time delay used for ~~zone~~ Zone 2 distance relays in transmission line protection. Longer time delays allow for slower slip rates.

### Application to Transmission Elements

~~The criteria~~ Criteria A in PRC-026-1 – Attachment B ~~describe a lens characteristic~~ describes an unstable power swing region that is formed by the union of three shapes in the impedance (R-X) plane. The first shape is a lower loss of synchronism circle based on a ratio of the sending-end to receiving-end voltages of 0.7 (i.e.,  $E_S / E_R = 0.7 / 1.0 = 0.7$ ). The second shape is an upper loss of synchronism circle based on a ratio of the receiving-end to sending-end voltages of 1.43 (i.e.,  $E_R / E_S = 1.0 / 0.7 = 1.43$ ). The third shape is a lens that connects the endpoints of the total system impedance together by varying the sending-end and receiving-end system voltages from 0.70 to 1.0 per unit, while maintaining a constant system separation angle across the total system impedance (with the parallel transfer impedance removed—see Figures 31 through 5). The total system impedance is derived from a two-bus equivalent network and is determined by summing the sending-end source impedance, the line impedance (excluding the Thévenin equivalent transfer impedance), and the receiving-end source impedance as shown in Figures 6 and 7. The goal in establishing the total system impedance is to represent a conservative condition that will maximize the security of the relay against various system conditions. The smallest total system impedance represents a condition where the size of the lens characteristic in the R-X plane is smallest and is a conservative operating point from the standpoint of ensuring a load-responsive protective relay will be expected to not trip given a predetermined angular displacement between the sending-end and receiving-end voltages. The smallest total system impedance results when all generation is in service and all transmission ~~elements~~ BES Elements are modeled in their “normal” system configuration (PRC-026-1 – Attachment B, Criteria A). The parallel transfer impedance is removed to represent a likely condition where parallel elements may be lost during the disturbance, and the loss of these elements magnifies the sensitivity of the load-responsive relays on the parallel line by removing the “infeed effect” (i.e., the apparent impedance sensed by the relay is decreased

## PRC-026-1 – Application Guidelines

as a result of the loss of the transfer impedance, thus making the relay more likely to trip for a stable power swing—See Figures 13 and 14).

The sending-~~end~~ and receiving-end source voltages are varied from 0.7 to 1.0 per unit to form a ~~portion~~the lower and upper loss of ~~a lens characteristic instead of varying the voltages from 0 to 1.0 per unit, which would form a full lens characteristic.~~synchronism circles. The ratio of these two voltages is used in the calculation of the ~~portion~~loss of ~~the lens~~synchronism circles, and result in a ratio range from 0.7 to 1.43.

$$\text{Eq. (2)} \quad \frac{E_S}{E_R} = \frac{0.7}{1.0} = 0.7$$

$$\text{Eq. (3):} \quad \frac{E_R}{E_S} = \frac{1.0}{0.7} = 1.43$$

The internal generator voltage during severe power swings or transmission system fault conditions will be greater than zero, due to voltage regulator support. The voltage ratio of 0.7 to 1.43 is chosen to be more conservative than the PRC-023<sup>10</sup> and PRC-025<sup>11</sup> NERC Reliability Standards, where a lower bound voltage of 0.85 per unit voltage is used. A ~~plus and minus~~±15% internal generator voltage range was chosen as a conservative voltage range for calculation of the voltage ratio ~~that would determine used to calculate~~ the ~~end points~~loss of ~~the portion of the lens~~synchronism circles. For example, the voltage ratio using these voltages would result in a ratio range from 0.739 to 1.353.

$$\text{Eq. (4)} \quad \frac{E_S}{E_R} = \frac{0.85}{1.15} = 0.739$$

$$\text{Eq. (5):} \quad \frac{E_R}{E_S} = \frac{1.15}{0.85} = 1.353$$

The lower ratio is rounded down to 0.7 to be more conservative, allowing a voltage range of 0.7 to 1.0 per unit to be used for the calculation of the ~~lens end points~~loss of synchronism circles.<sup>12</sup>

When the parallel transfer impedance is included in the model, the split in current through the parallel transfer impedance path results in actual measured relay impedances that are larger than those measured when the parallel transfer impedance is removed (i.e., infeed effect), which would make it more likely for an impedance relay element to be completely contained within the ~~applicable portion of the lens characteristic~~unstable power swing region in Figure 11. If the transfer impedance is included in the ~~lens~~ evaluation, a distance relay element could be deemed as meeting PRC-026-1 – Attachment B and, in fact would be secure, assuming all elements were in their normal state. In this case, ~~the distance relay element~~ could trip for a stable power swing during an actual event if the system was weakened (i.e., a higher transfer impedance) by the loss of a subset of lines that make up the parallel transfer impedance. This could happen because ~~those~~the subset of lines that make up the parallel ~~line~~transfer impedance tripped on unstable swings,

---

<sup>10</sup> Transmission Relay Loadability

<sup>11</sup> Generator Relay Loadability

<sup>12</sup> *Final Report on the August 14, 2003 Blackout in the United States and Canada: Causes and Recommendations*, April 2004, Section 6 (The Cascade Stage of the Blackout), p. 94 under “Why the Generators Tripped Off,” states, “Some generator undervoltage relays were set to trip at or above 90% voltage. However, a motor stalls out at about 70% voltage and a motor starter contactor drops out around 75%, so if there is a compelling need to protect the turbine from the system the under-voltage trigger point should be no higher than 80%.”



contained the initiating fault, and/or were lost due to operation of breaker failure or remote back-up protection schemes in Figure 10.

Table 10 shows the percent size increase of the lens shape as seen by the relay under evaluation when the parallel transfer impedance is included. The parallel transfer impedance has minimal effect on the apparent size of the lens shape as long as the parallel transfer impedance is at least 10 multiples of the parallel line impedance (less than 5% lens shape expansion), therefore, its removal has minimal impact, but results in a slightly more conservative, smaller lens shape. Transfer impedances of 5 multiples of the parallel line impedance or less result in an apparent lens shape size of 10% or greater as seen by the relay. If two parallel lines and a parallel transfer impedance tie the sending-end and receiving-end buses together, the total parallel transfer impedance will be one or less multiples of the parallel line impedance, resulting in an apparent lens shape size of 45% or greater. It is a realistic contingency that the parallel line could be out-of-service, leaving the transfer impedance making up the rest of the system in parallel with the line impedance. Since it is not known exactly which lines making up the parallel transfer impedance that will be out of service during a major system disturbance, it is most conservative to assume that all of them are out, leaving just the line under evaluation in service.

Either the saturated transient or sub-transient direct axis reactance values may be used for machines in the evaluation because they are smaller than un-saturated reactance values. Since, sub-transient saturated generator reactances are smaller than the transient or synchronous reactance, they result in a smaller source impedance and a smaller ~~lens-characteristic~~unstable power swing region in the graphical analysis as shown in Figures 8 and 9. Since power swings occur in a time frame where generator transient reactances will be prevalent, it is acceptable to use saturated transient reactances instead of saturated sub-transient reactance values. Some short-circuit models may not include transient reactance values, so in this case, the use of sub-transient is acceptable because it also produces more conservative results than transient reactances. For this reason, either value is acceptable when determining the system source impedances (PRC-026-1 – Attachment B, Criteria A and B, No. 3).

Saturated reactance values are also the values used in short-circuit programs that produce the system impedance mentioned above. Planning and stability software generally use the un-saturated reactance values. Generator models used in transient stability analyses recognize that the extent of the saturation effect depends upon both rotor (field) and stator currents. Accordingly, they derive the effective saturated parameters of the machine at each instant by internal calculation from the specified (constant) unsaturated values of machine reactances and the instantaneous internal flux level. The specific assumptions regarding which inductances are affected by saturation, and the relative effect of that saturation, are different for the various generator models used. Thus, unsaturated values of all machine reactances are used in setting up planning and stability software data, and the appropriate set of open-circuit magnetization curve data is provided for each machine.

Saturated reactance values are smaller than unsaturated reactance values and are used in short-circuit programs owned by the Generator and Transmission Owners. Because of this, saturated reactance values are to be used in the development of the system source impedances.

## PRC-026-1 – Application Guidelines

---

The source or system equivalent impedances can be obtained by a number of different methods using commercially available short-circuit calculation tools.<sup>13</sup> Most short-circuit tools have a network reduction feature that allows the user to select the local and remote terminal buses to retain. The first method reduces the system to one that contains two buses, an equivalent generator at each bus (representing the source impedance at the sending-end and receiving-ends), and two parallel lines; one being the line impedance of the protected line with relays being analyzed, the other being the transfer impedance representing all other combinations of lines that connect the two buses together as shown in Figure 6. Another conservative method is to open both ends of the line in question, and apply a three-phase bolted fault at each bus. The resulting source impedance at each end will be less than or equal to the actual source impedance calculated by the network reduction method. Either method can be used to develop the system source impedances at both ends.

The two bullets of PRC-026-1 – Attachment B, Criteria A, No. 1, identify the system separation angles to identify the size of the power swing stability boundary to be used to test load-responsive protective relay impedance-relay elements. Both bullets test impedance relay elements that are not supervised by power swing blocking- (PSB). The first bullet of PRC-026-1 – Attachment B, Criteria A, No. 1 evaluates a system separation angle of at least 120 degrees that is held constant while varying the sending-end and receiving-end source voltages from 0.7 to 1.0 per unit, thus creating an unstable power swing stability boundary shaped like a portion of a lens region about the total system impedance in Figure 31. This portion of a lens characteristic unstable power swing region is compared to the tripping portion of the distance relay characteristic; that is, the portion that is not supervised by load encroachment, blinders, or some other form of supervision as shown in Figure 12 that restricts the distance element from tripping for heavy, balanced load conditions. If the tripping portion of the impedance characteristics are completely contained within the portion of a lens characteristic unstable power swing region, the Element relay impedance element meets Criteria A in PRC-026-1 – Attachment B. A system separation angle of 120 degrees was chosen for the evaluation where PSB is not applied because it is generally accepted in the industry that recovery for a swing beyond this angle is unlikely to occur.<sup>14</sup>

The second bullet of PRC-026-1 – Attachment B, Criteria A, No. 1 evaluates impedance relay elements at a system separation angle of less than 120 degrees, similar to the first bullet described above. An angle less than 120 degrees may be used if a documented stability analysis demonstrates that the power swing becomes unstable at a system separation angle of less than 120 degrees.

The exclusion of relay elements supervised by PSB in PRC-026-1 – Attachment A allows the Generator Owner or Transmission Owner to exclude protective relay elements if they are blocked

---

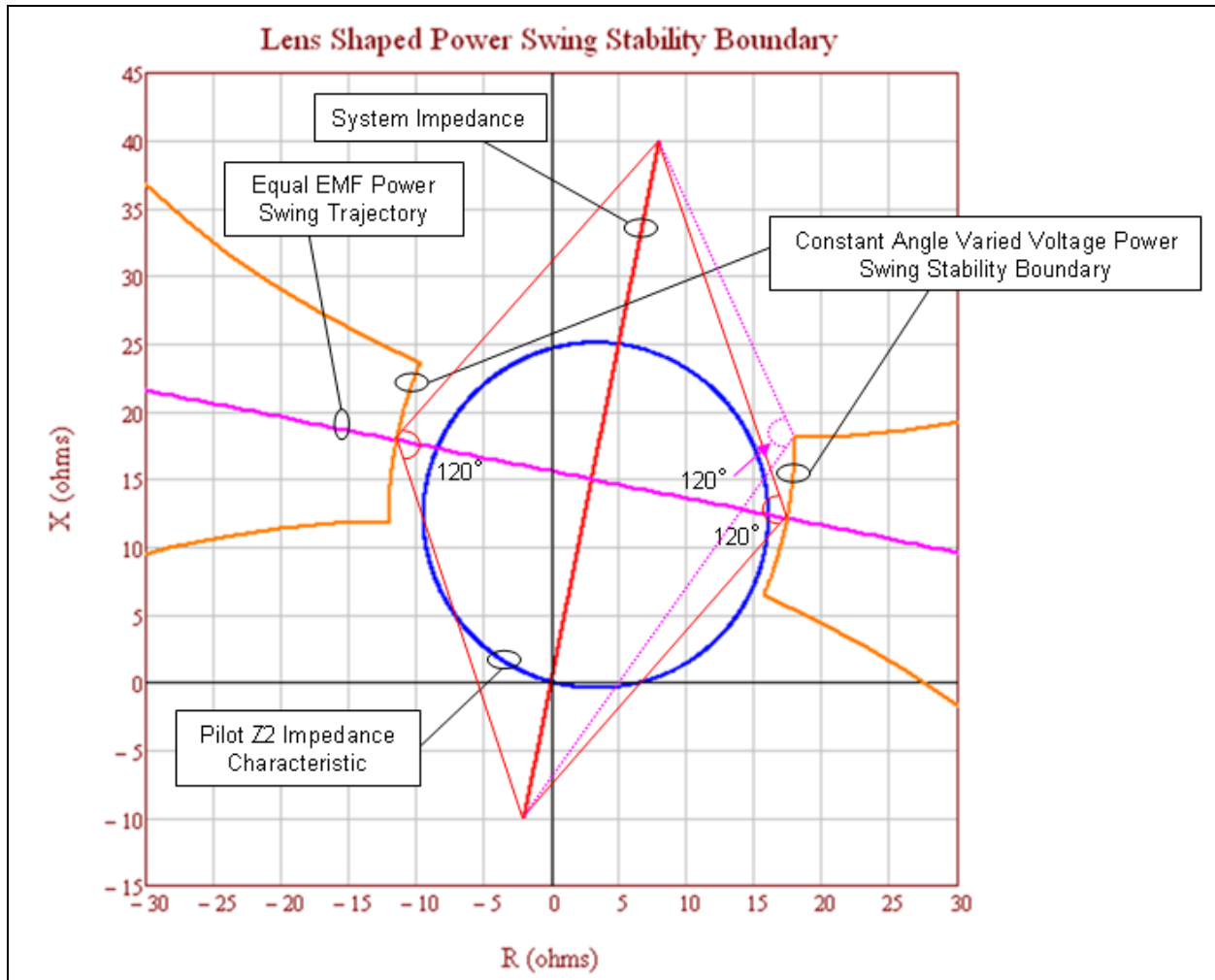
<sup>13</sup> Demetrios A. Tziouvaras and Daqing Hou, Appendix in *Out-Of-Step Protection Fundamentals and Advancements*, April 17, 2014: <https://www.selinc.com>.

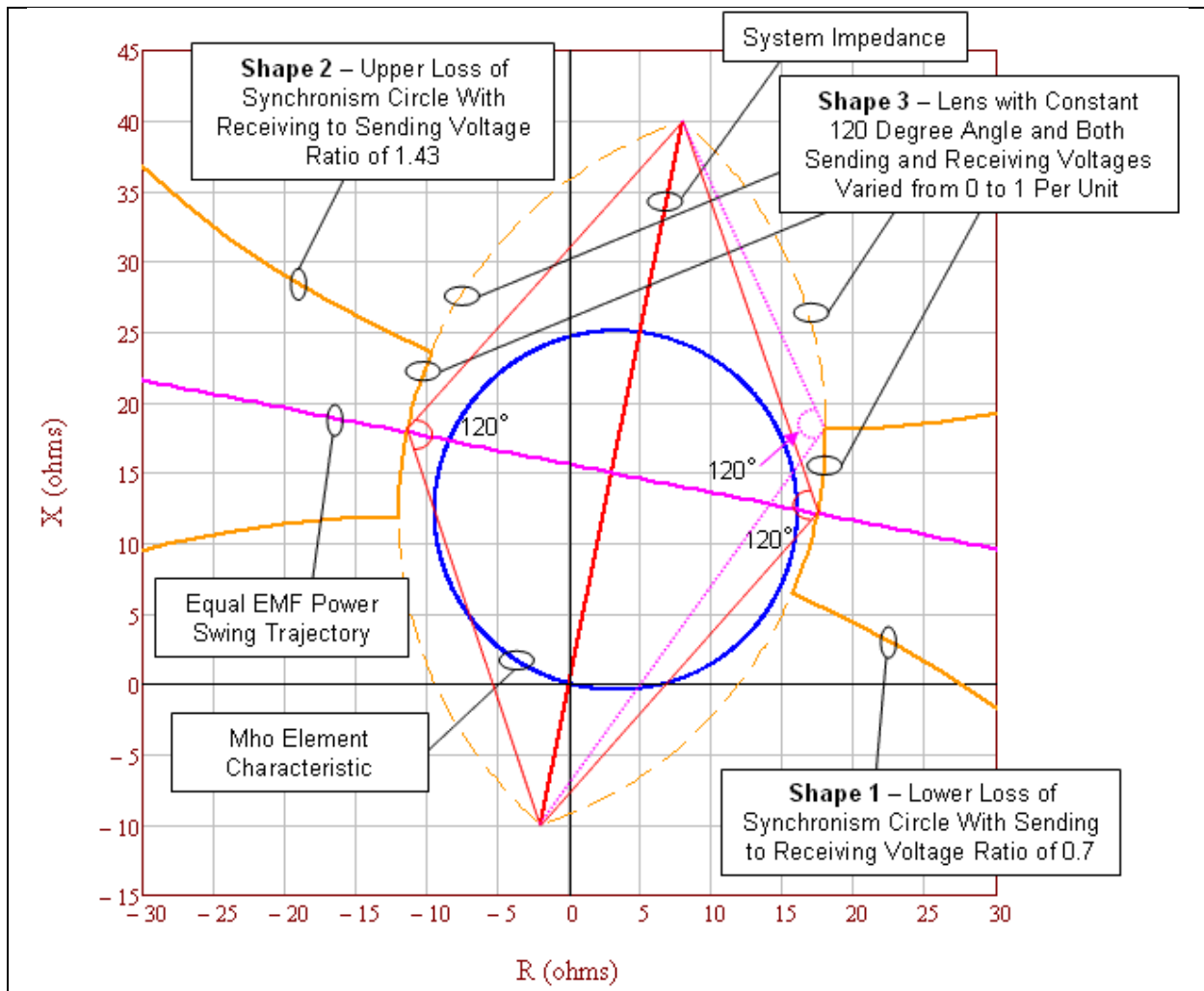
<sup>14</sup> “The critical angle for maintaining stability will vary depending on the contingency and the system condition at the time the contingency occurs; however, the likelihood of recovering from a swing that exceeds 120 degrees is marginal and 120 degrees is generally accepted as an appropriate basis for setting out-of-step protection. Given the importance of separating unstable systems, defining 120 degrees as the critical angle is appropriate to achieve a proper balance between dependable tripping for unstable power swings and secure operation for stable power swings.” NERC System Protection and Control Subcommittee, *Protection System Response to Power Swings*, August 2013: [http://www.nerc.com/comm/PC/System%20Protection%20and%20Control%20Subcommittee%20SPCS%202020/SPCS%20Power%20Swing%20Report\\_Final\\_20131015.pdf](http://www.nerc.com/comm/PC/System%20Protection%20and%20Control%20Subcommittee%20SPCS%202020/SPCS%20Power%20Swing%20Report_Final_20131015.pdf), p. 28.

## **PRC-026-1 – Application Guidelines**

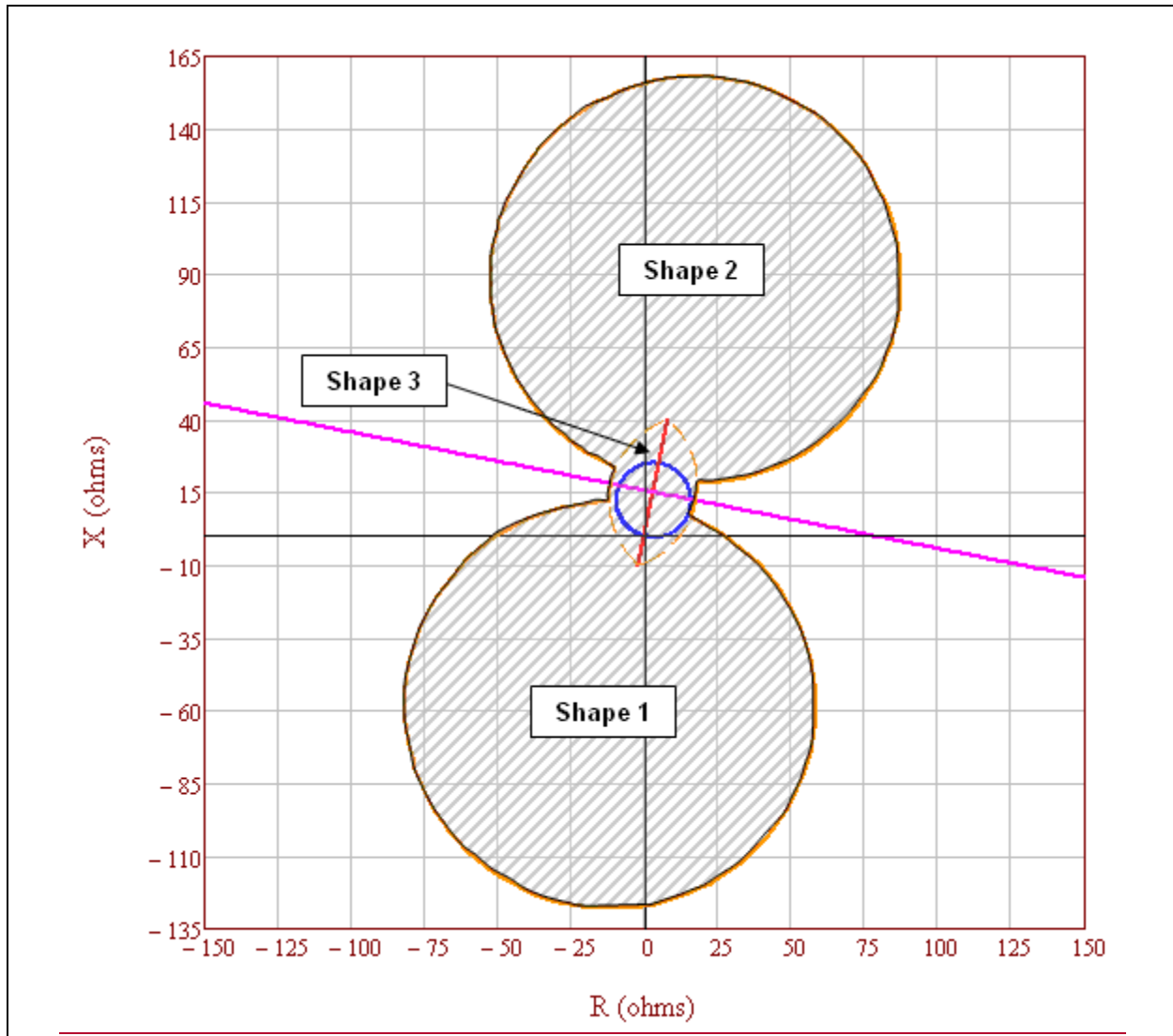
---

from tripping by PSB relays. A PSB relay applied and set according to industry accepted practices prevent supervised load-responsive protective relays from tripping in response to power swings. Further, PSB relays are set to allow dependable tripping of supervised elements. The criteria in PRC-026-1 – Attachment B specifically applies to unsupervised elements that could trip for stable power swings. Therefore, load-responsive protective relay elements supervised by PSB can be excluded from the Requirements of this standard.

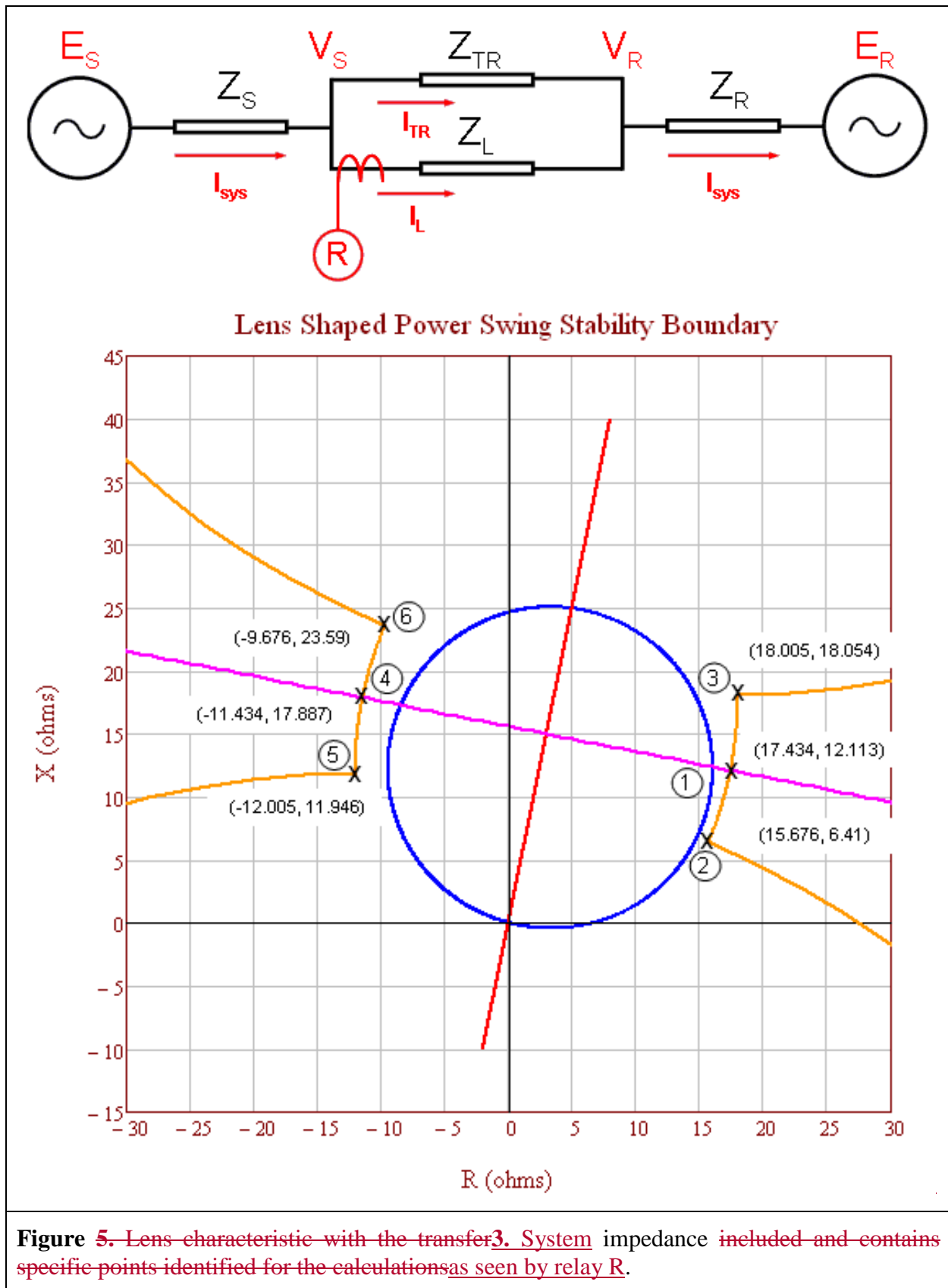


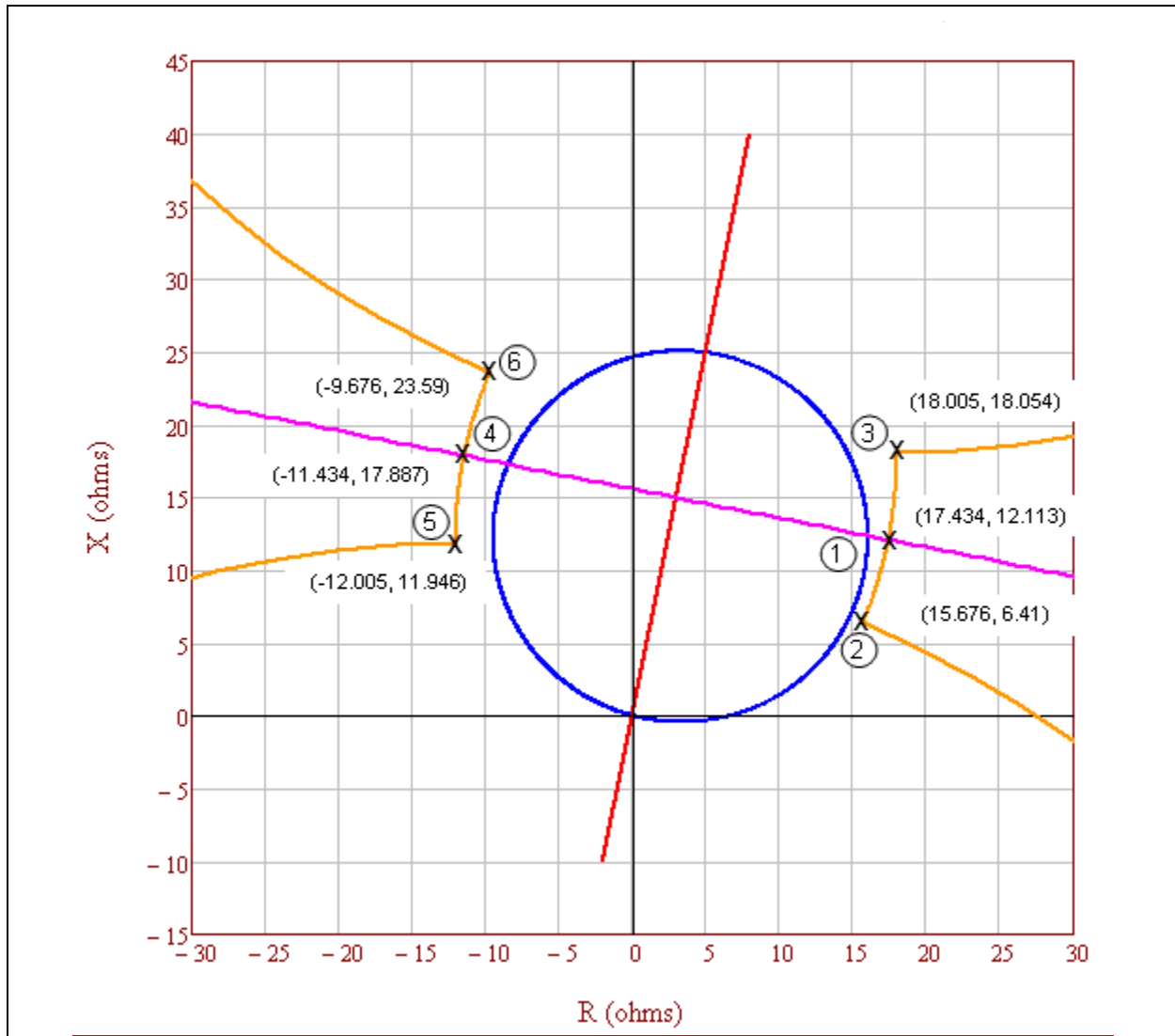


**Figure 3.** The portion of 1. An enlarged graphic illustrating the lens characteristic that is unstable power swing region formed by the union of three shapes in the impedance (R-X) plane. The pilot zone 2 relay: Shape 1) Lower loss of synchronism circle, Shape 2) Upper loss of synchronism circle, and Shape 3) Lens. The mho element characteristic is completely contained within the portion of the lens unstable power swing region (e.g., it does not intersect any portion of the partial lens unstable power swing region), therefore it complies with PRC-026-1 – Attachment B, Criteria A, No. 1.



**Figure 4.** System impedance as seen by relay R. **Figure 2.** Full graphic of unstable power swing region formed by the union of three shapes in the impedance (R-X) plane: Shape 1) Lower loss of synchronism circle, Shape 2) Upper loss of synchronism circle, and Shape 3) Lens. The mho element characteristic is completely contained within the unstable power swing region, therefore it meets PRC-26-1 – Attachment B, Criteria A, No.1.





**Figure 4.** The defining unstable power swing region points where the lens shape intersects the lower and upper loss of synchronism circle shapes and where the lens intersects the equal EMF (electromotive force) power swing.



Voltage (p.u.)	Left Side Coordinates		Right Side Coordinates	
	R	+ jX	R	+ jX
<b>0.7</b>	<b>-12.005</b>	<b>11.946</b>	<b>15.676</b>	<b>6.41</b>
0.72	-12.004	12.407	15.852	6.836
0.74	-11.996	12.857	16.018	7.255
0.76	-11.982	13.298	16.175	7.667
0.78	-11.961	13.729	16.321	8.073
0.8	-11.935	14.151	16.459	8.472
0.82	-11.903	14.563	16.589	8.865
0.84	-11.867	14.966	16.71	9.251
0.86	-11.826	15.361	16.824	9.631
0.88	-11.78	15.746	16.93	10.004
0.9	-11.731	16.123	17.03	10.371
0.92	-11.678	16.492	17.123	10.732
0.94	-11.621	16.852	17.209	11.086
0.96	-11.562	17.205	17.29	11.435
0.98	-11.499	17.55	17.364	11.777
<b>1</b>	<b>-11.434</b>	<b>17.887</b>	<b>17.434</b>	<b>12.113</b>
0.98	-11.364	18.223	17.499	12.45
0.96	-11.29	18.565	17.562	12.795
0.94	-11.209	18.914	17.621	13.148
0.92	-11.123	19.268	17.678	13.508
0.9	-11.03	19.629	17.731	13.877
0.88	-10.93	19.996	17.78	14.254
0.86	-10.824	20.369	17.826	14.639
0.84	-10.71	20.749	17.867	15.034
0.82	-10.589	21.135	17.903	15.437
0.8	-10.459	21.528	17.935	15.849
0.78	-10.321	21.927	17.961	16.271
0.76	-10.175	22.333	17.982	16.702
0.74	-10.018	22.745	17.996	17.143
0.72	-9.852	23.164	18.004	17.593
<b>0.7</b>	<b>-9.676</b>	<b>23.59</b>	<b>18.005</b>	<b>18.054</b>

**Figure 5.** Full table of 31 detailed lens shape point calculations. The bold highlighted rows correspond to the detailed calculations in Tables 2-7.

**Table 2. Example Calculation (Lens Point 1)**

This example is for calculating the impedance the first point of the lens characteristic. Equal source voltages are used for the 230 kV (base) line with the sending-end voltage ( $E_S$ ) leading the receiving-end voltage ( $E_R$ ) by 120 degrees. See Figures 43 and 54.

Eq. (6)	$E_S = \frac{V_{LL} \angle 120^\circ}{\sqrt{3}}$
	$E_S = \frac{230,000 \angle 120^\circ V}{\sqrt{3}}$

<b>Table 2. Example Calculation (Lens Point 1)</b>			
	$E_S = 132,791 \angle 120^\circ V$		
Eq. (7)	$E_R = \frac{V_{LL} \angle 0^\circ}{\sqrt{3}}$		
	$E_R = \frac{230,000 \angle 0^\circ V}{\sqrt{3}}$		
	$E_R = 132,791 \angle 0^\circ V$		
Given positive sequence impedance data (The transfer impedance $Z_{TR}$ is set to infinity).			
Given:	$Z_S = 2 + j10 \Omega$	$Z_L = 4 + j20 \Omega$	$Z_R = 4 + j20 \Omega$
Given:	$Z_{TR} = Z_L \times 10^{10} \Omega$		
Total impedance between generators.			
Eq. (8)	$Z_{total} = \frac{(Z_L \times Z_{TR})}{(Z_L + Z_{TR})}$		
	$Z_{total} = \frac{((4 + j20) \Omega \times (4 + j20)^{10} \Omega)}{((4 + j20) \Omega + (4 + j20)^{10} \Omega)}$		
	$Z_{total} = 4 + j20 \Omega$		
Total system impedance.			
Eq. (9)	$Z_{sys} = Z_S + Z_{total} + Z_R$		
	$Z_{sys} = (2 + j10) \Omega + (4 + j20) \Omega + (4 + j20) \Omega$		
	$Z_{sys} = 10 + j50 \Omega$		
Total system current from sending- <del>end</del> source.			
Eq. (10)	$I_{sys} = \frac{E_S - E_R}{Z_{sys}}$		
	$I_{sys} = \frac{132,791 \angle 120^\circ V - 132,791 \angle 0^\circ V}{(10 + j50) \Omega}$		
	$I_{sys} = 4,511 \angle 71.3^\circ A$		
The current as measured by the relay on $Z_L$ is only the current flowing through that line as determined by using the current divider equation.			
Eq. (11)	$I_L = I_{sys} \times \frac{Z_{TR}}{Z_L + Z_{TR}}$		
	$I_L = 4,511 \angle 71.3^\circ A \times \frac{(4 + j20)^{10} \Omega}{(4 + j20) \Omega + (4 + j20)^{10} \Omega}$		
	$I_L = 4,511 \angle 71.3^\circ A$		

**Table 2. Example Calculation (Lens Point 1)**

The voltage as measured by the relay on  $Z_L$  is the voltage drop from the sending-end source through the sending-end source impedance.

Eq. (12)	$V_S = E_S - (Z_S \times I_{sys})$
	$V_S = 132,791 \angle 120^\circ V - [(2 + j10) \Omega \times 4,511 \angle 71.3^\circ A]$
	$V_S = 95,757 \angle 106.1^\circ V$
The impedance seen by the relay on $Z_L$ .	
Eq. (13)	$Z_{L-Relay} = \frac{V_S}{I_L}$
	$Z_{L-Relay} = \frac{95,757 \angle 106.1^\circ V}{4,511 \angle 71.3^\circ A}$
	$Z_{L-Relay} = 17.434 + j12.113 \Omega$

**Table 3. Example Calculation (Lens Point 2)**

This example is for calculating the impedance second point of the lens characteristic. Unequal source voltages are used for the 230 kV (base) line with the sending-end voltage ( $E_S$ ) at 70% of the receiving-end voltage ( $E_R$ ) and leading the receiving-end voltage by 120 degrees. See Figures 43 and 54.

Eq. (14)	$E_S = \frac{V_{LL} \angle 120^\circ}{\sqrt{3}} \times 70\%$
	$E_S = \frac{230,000 \angle 120^\circ V}{\sqrt{3}} \times 0.70$
	$E_S = 92,953.7 \angle 120^\circ V$
Eq. (15)	$E_R = \frac{V_{LL} \angle 0^\circ}{\sqrt{3}}$
	$E_R = \frac{230,000 \angle 0^\circ V}{\sqrt{3}}$
	$E_R = 132,791 \angle 0^\circ V$
Given positive sequence impedance data (The transfer impedance $Z_{TR}$ is set to infinity).	
Given:	$Z_S = 2 + j10 \Omega$ $Z_L = 4 + j20 \Omega$ $Z_R = 4 + j20 \Omega$
Given:	$Z_{TR} = Z_L \times 10^{10} \Omega$

<b>Table 3. Example Calculation (Lens Point 2)</b>	
Total impedance between generators.	
Eq. (16)	$Z_{total} = \frac{(Z_L \times Z_{TR})}{(Z_L + Z_{TR})}$
	$Z_{total} = \frac{((4 + j20) \Omega \times (4 + j20)^{10} \Omega)}{((4 + j20) \Omega + (4 + j20)^{10} \Omega)}$
	$Z_{total} = 4 + j20 \Omega$
Total system impedance.	
Eq. (17)	$Z_{sys} = Z_S + Z_{total} + Z_R$
	$Z_{sys} = (2 + j10) \Omega + (4 + j20) \Omega + (4 + j20) \Omega$
	$Z_{sys} = 10 + j50 \Omega$
Total system current from sending- <u>end</u> source.	
Eq. (18)	$I_{sys} = \frac{E_S - E_R}{Z_{sys}}$
	$I_{sys} = \frac{92,953.7 \angle 120^\circ V - 132,791 \angle 0^\circ V}{(10 + j50) \Omega}$
	$I_{sys} = 3,854 \angle 77^\circ A$
The current as measured by the relay on ZL is only the current flowing through that line as determined by using the current divider equation.	
Eq. (19)	$I_L = I_{sys} \times \frac{Z_{TR}}{Z_L + Z_{TR}}$
	$I_L = 3,854 \angle 77^\circ A \times \frac{(4 + j20)^{10} \Omega}{(4 + j20) \Omega + (4 + j20)^{10} \Omega}$
	$I_L = 3,854 \angle 77^\circ A$
The voltage as measured by the relay on ZL is the voltage drop from the sending- <u>end</u> source through the sending- <u>end</u> source impedance.	
Eq. (20)	$V_S = E_S - (Z_S \times I_{sys})$
	$V_S = 92,953 \angle 120^\circ V - [(2 + j10) \Omega \times 3,854 \angle 77^\circ A]$
	$V_S = 65,271 \angle 99^\circ V$
The impedance seen by the relay on ZL.	
Eq. (21)	$Z_{L-Relay} = \frac{V_S}{I_L}$

**Table 3. Example Calculation (Lens Point 2)**

	$Z_{L-Relay} = \frac{65,271 \angle 99^\circ V}{3,854 \angle 77^\circ A}$
	$Z_{L-Relay} = 15.676 + j6.41 \Omega$

**Table 4. Example Calculation (Lens Point 3)**

This example is for calculating the impedance third point of the lens characteristic. Unequal source voltages are used for the 230 kV (base) line with the receiving-end voltage ( $E_R$ ) at 70% of the sending-end voltage ( $E_S$ ) and the sending-end voltage leading the receiving-end voltage by 120 degrees. See Figures 43 and 54.

Eq. (22)	$E_S = \frac{V_{LL} \angle 120^\circ}{\sqrt{3}}$
	$E_S = \frac{230,000 \angle 120^\circ V}{\sqrt{3}}$
	$E_S = 132,791 \angle 120^\circ V$
Eq. (23)	$E_R = \frac{V_{LL} \angle 0^\circ}{\sqrt{3}} \times 70\%$
	$E_R = \frac{230,000 \angle 0^\circ V}{\sqrt{3}} \times 0.70$
	$E_R = 92,953.7 \angle 0^\circ V$
Given positive sequence impedance data (The transfer impedance $Z_{TR}$ is set to infinity).	
Given:	$Z_S = 2 + j10 \Omega$ $Z_L = 4 + j20 \Omega$ $Z_R = 4 + j20 \Omega$
Given:	$Z_{TR} = Z_L \times 10^{10} \Omega$
Total impedance between generators.	
Eq. (24)	$Z_{total} = \frac{(Z_L \times Z_{TR})}{(Z_L + Z_{TR})}$
	$Z_{total} = \frac{((4 + j20) \Omega \times (4 + j20)^{10} \Omega)}{((4 + j20) \Omega + (4 + j20)^{10} \Omega)}$
	$Z_{total} = 4 + j20 \Omega$
Total system impedance.	
Eq. (25)	$Z_{sys} = Z_S + Z_{total} + Z_R$
	$Z_{sys} = (2 + j10) \Omega + (4 + j20) \Omega + (4 + j20) \Omega$
	$Z_{sys} = 10 + j50 \Omega$

Table 4. Example Calculation (Lens Point 3)	
Total system current from sending- <u>end</u> source.	
Eq. (26)	$I_{sys} = \frac{E_S - E_R}{Z_{sys}}$
	$I_{sys} = \frac{132,791 \angle 120^\circ V - 92,953.7 \angle 0^\circ V}{(10 + j50) \Omega}$
	$I_{sys} = 3,854 \angle 65.5^\circ A$
The current as measured by the relay on ZL is only the current flowing through that line as determined by using the current divider equation.	
Eq. (27)	$I_L = I_{sys} \times \frac{Z_{TR}}{Z_L + Z_{TR}}$
	$I_L = 3,854 \angle 65.5^\circ A \times \frac{(4 + j20)^{10} \Omega}{(4 + j20) \Omega + (4 + j20)^{10} \Omega}$
	$I_L = 3,854 \angle 65.5^\circ A$
The voltage as measured by the relay on ZL is the voltage drop from the sending- <u>end</u> source through the sending- <u>end</u> source impedance.	
Eq. (28)	$V_S = E_S - (Z_S \times I_L)$
	$V_S = 132,791 \angle 120^\circ V - [(2 + j10) \Omega \times 3,854 \angle 65.5^\circ A]$
	$V_S = 98,265 \angle 110.6^\circ V$
The impedance seen by the relay on ZL.	
Eq. (29)	$Z_{L-Relay} = \frac{V_S}{I_L}$
	$Z_{L-Relay} = \frac{98,265 \angle 110.6^\circ V}{3,854 \angle 65.5^\circ A}$
	$Z_{L-Relay} = 18.005 + j18.054 \Omega$

Table 5. Example Calculation (Lens Point 4)	
This example is for calculating the impedance fourth point of the lens characteristic. Equal source voltages are used for the 230 kV (base) line with the sending- <u>end</u> voltage (E <sub>S</sub> ) leading the receiving- <u>end</u> voltage (E <sub>R</sub> ) by 240 degrees. See Figures 43 and 54.	
Eq. (30)	$E_S = \frac{V_{LL} \angle 240^\circ}{\sqrt{3}}$

Table 5. Example Calculation (Lens Point 4)			
	$E_S = \frac{230,000 \angle 240^\circ V}{\sqrt{3}}$		
	$E_S = 132,791 \angle 240^\circ V$		
Eq. (31)	$E_R = \frac{V_{LL} \angle 0^\circ}{\sqrt{3}}$		
	$E_R = \frac{230,000 \angle 0^\circ V}{\sqrt{3}}$		
	$E_R = 132,791 \angle 0^\circ V$		
Given positive sequence impedance data (The transfer impedance $Z_{TR}$ is set to infinity).			
Given:	$Z_S = 2 + j10 \Omega$	$Z_L = 4 + j20 \Omega$	$Z_R = 4 + j20 \Omega$
Given:	$Z_{TR} = Z_L \times 10^{10} \Omega$		
Total impedance between generators.			
Eq. (32)	$Z_{total} = \frac{(Z_L \times Z_{TR})}{(Z_L + Z_{TR})}$		
	$Z_{total} = \frac{((4 + j20) \Omega \times (4 + j20)^{10} \Omega)}{((4 + j20) \Omega + (4 + j20)^{10} \Omega)}$		
	$Z_{total} = 4 + j20 \Omega$		
Total system impedance.			
Eq. (33)	$Z_{sys} = Z_S + Z_{total} + Z_R$		
	$Z_{sys} = (2 + j10) \Omega + (4 + j20) \Omega + (4 + j20) \Omega$		
	$Z_{sys} = 10 + j50 \Omega$		
Total system current from sending- <u>end</u> source.			
Eq. (34)	$I_{sys} = \frac{E_S - E_R}{Z_{sys}}$		
	$I_{sys} = \frac{132,791 \angle 240^\circ V - 132,791 \angle 0^\circ V}{(10 + j50) \Omega}$		
	$I_{sys} = 4,510 \angle 131.3^\circ A$		
The current as measured by the relay on ZL is only the current flowing through that line as determined by using the current divider equation.			
Eq. (35)	$I_L = I_{sys} \times \frac{Z_{TR}}{Z_L + Z_{TR}}$		

Table 5. Example Calculation (Lens Point 4)	
	$I_L = 4,510 \angle 131.1^\circ A \times \frac{(4 + j20)^{10} \Omega}{(4 + j20) \Omega + (4 + j20)^{10} \Omega}$
	$I_L = 4,510 \angle 131.1^\circ A$
The voltage as measured by the relay on $Z_L$ is the voltage drop from the sending- <u>end</u> source through the sending- <u>end</u> source impedance.	
Eq. (36)	$V_S = E_S - (Z_S \times I_L)$
	$V_S = 132,791 \angle 240^\circ V - [(2 + j10) \Omega \times 4,510 \angle 131.1^\circ A]$
	$V_S = 95,756 \angle -106.1^\circ V$
The impedance seen by the relay on $Z_L$ .	
Eq. (37)	$Z_{L-Relay} = \frac{V_S}{I_L}$
	$Z_{L-Relay} = \frac{95,756 \angle -106.1^\circ V}{4,510 \angle 131.1^\circ A}$
	$Z_{L-Relay} = -11.434 + j17.887 \Omega$

Table 6. Example Calculation (Lens Point 5)				
This example is for calculating the impedance fifth point of the lens characteristic. Unequal source voltages are used for the 230 kV (base) line with the sending- <u>end</u> voltage ( $E_S$ ) at 70% of the receiving- <u>end</u> voltage ( $E_R$ ) and leading the receiving- <u>end</u> voltage by 240 degrees. See Figures <a href="#">43</a> and <a href="#">54</a> .				
Eq. (38)	$E_S = \frac{V_{LL} \angle 240^\circ}{\sqrt{3}} \times 70\%$			
	$E_S = \frac{230,000 \angle 240^\circ V}{\sqrt{3}} \times 0.70$			
	$E_S = 92,953.7 \angle 240^\circ V$			
Eq. (39)	$E_R = \frac{V_{LL} \angle 0^\circ}{\sqrt{3}}$			
	$E_R = \frac{230,000 \angle 0^\circ V}{\sqrt{3}}$			
	$E_R = 132,791 \angle 0^\circ V$			
Given positive sequence impedance data (The transfer impedance $Z_{TR}$ is set to infinity).				
Given:	<table border="1" style="width: 100%; border-collapse: collapse;"> <tr> <td style="text-align: center;"><math>Z_S = 2 + j10 \Omega</math></td> <td style="text-align: center;"><math>Z_L = 4 + j20 \Omega</math></td> <td style="text-align: center;"><math>Z_R = 4 + j20 \Omega</math></td> </tr> </table>	$Z_S = 2 + j10 \Omega$	$Z_L = 4 + j20 \Omega$	$Z_R = 4 + j20 \Omega$
$Z_S = 2 + j10 \Omega$	$Z_L = 4 + j20 \Omega$	$Z_R = 4 + j20 \Omega$		



<b>Table 6. Example Calculation (Lens Point 5)</b>	
Given:	$Z_{TR} = Z_L \times 10^{10} \Omega$
Total impedance between generators.	
Eq. (40)	$Z_{total} = \frac{(Z_L \times Z_{TR})}{(Z_L + Z_{TR})}$
	$Z_{total} = \frac{((4 + j20) \Omega \times (4 + j20)^{10} \Omega)}{((4 + j20) \Omega + (4 + j20)^{10} \Omega)}$
	$Z_{total} = 4 + j20 \Omega$
Total system impedance.	
Eq. (41)	$Z_{sys} = Z_S + Z_{total} + Z_R$
	$Z_{sys} = (2 + j10 \Omega) + (4 + j20 \Omega) + (4 + j20 \Omega)$
	$Z_{sys} = 10 + j50 \Omega$
Total system current from sending-end source.	
Eq. (42)	$I_{sys} = \frac{E_S - E_R}{Z_{sys}}$
	$I_{sys} = \frac{92,953.7 \angle 240^\circ V - 132,791 \angle 0^\circ V}{10 + j50 \Omega}$
	$I_{sys} = 3,854 \angle 125.5^\circ A$
The current as measured by the relay on $Z_L$ is only the current flowing through that line as determined by using the current divider equation.	
Eq. (43)	$I_L = I_{sys} \times \frac{Z_{TR}}{Z_L + Z_{TR}}$
	$I_L = 3,854 \angle 125.5^\circ A \times \frac{(4 + j20)^{10} \Omega}{(4 + j20) \Omega + (4 + j20)^{10} \Omega}$
	$I_L = 3,854 \angle 125.5^\circ A$
The voltage as measured by the relay on $Z_L$ is the voltage drop from the sending-end source through the sending-end source impedance.	
Eq. (44)	$V_S = E_S - (Z_S \times I_L)$
	$V_S = 92,953.7 \angle 240^\circ V - [(2 + j10) \Omega \times 3,854 \angle 125.5^\circ A]$
	$V_S = 65,270.5 \angle -99.4^\circ V$
The impedance seen by the relay on $Z_L$ .	
Eq. (45)	$Z_{L-Relay} = \frac{V_S}{I_L}$

**Table 6. Example Calculation (Lens Point 5)**

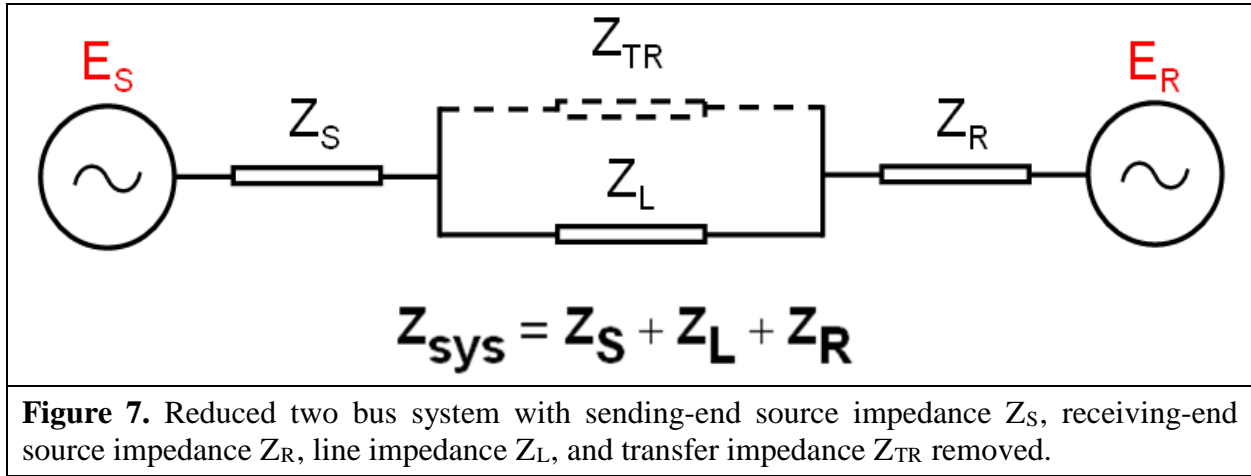
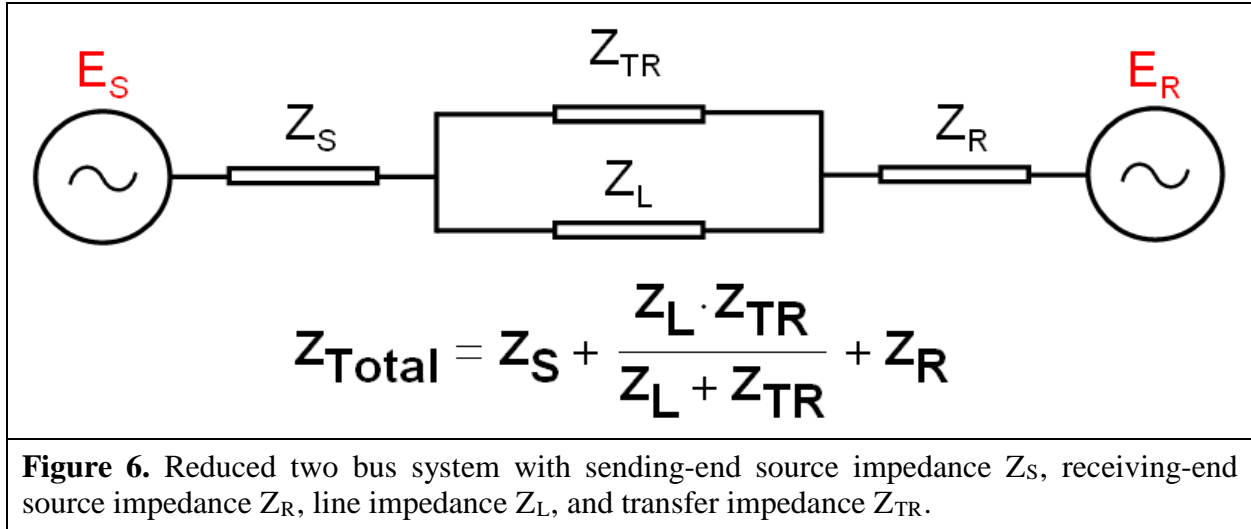
	$Z_{L-Relay} = \frac{65,270.5 \angle -99.4^\circ V}{3,854 \angle 125.5^\circ A}$
	$Z_{L-Relay} = -12.005 + j11.946 \Omega$

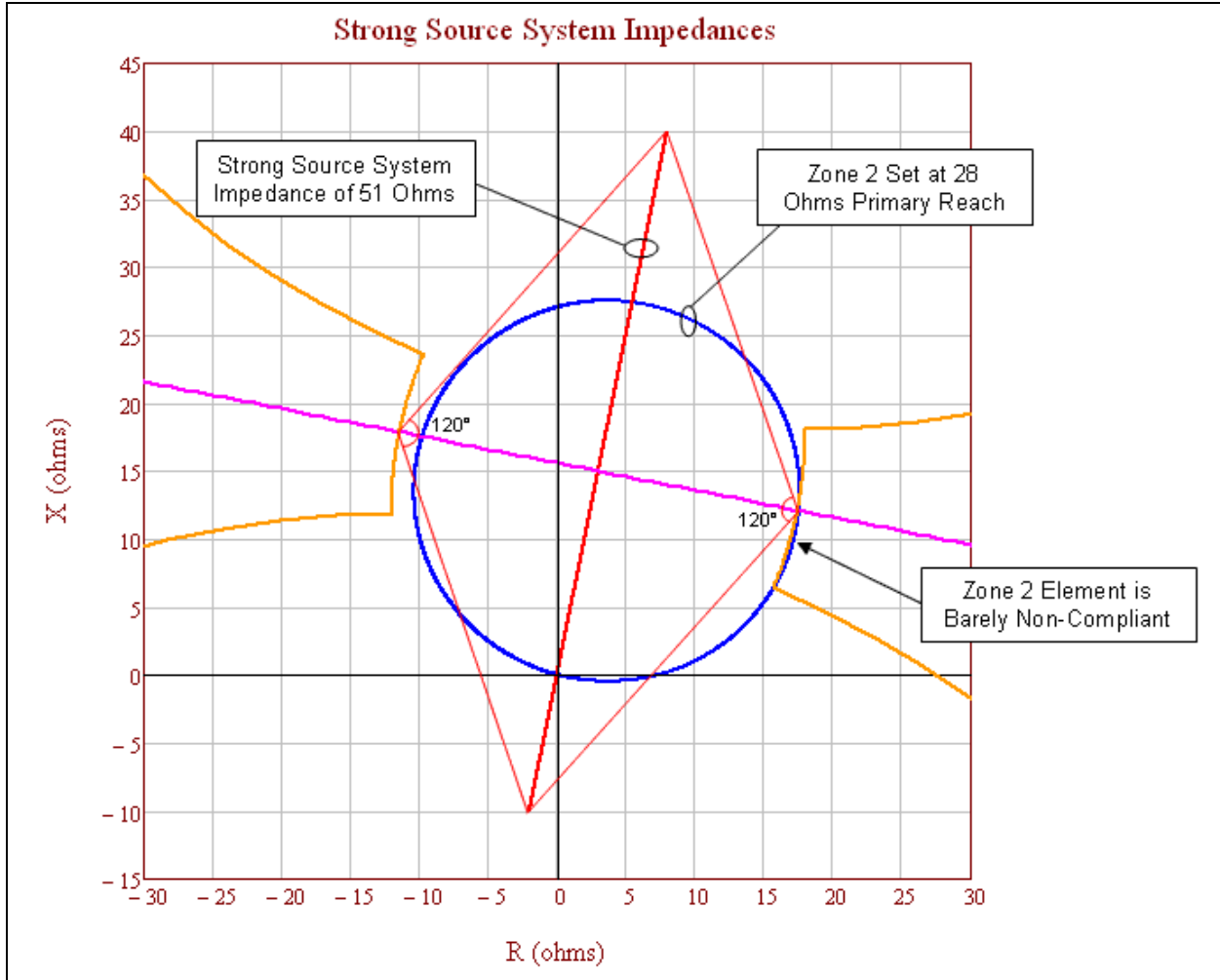
**Table 7. Example Calculation (Lens Point 6)**

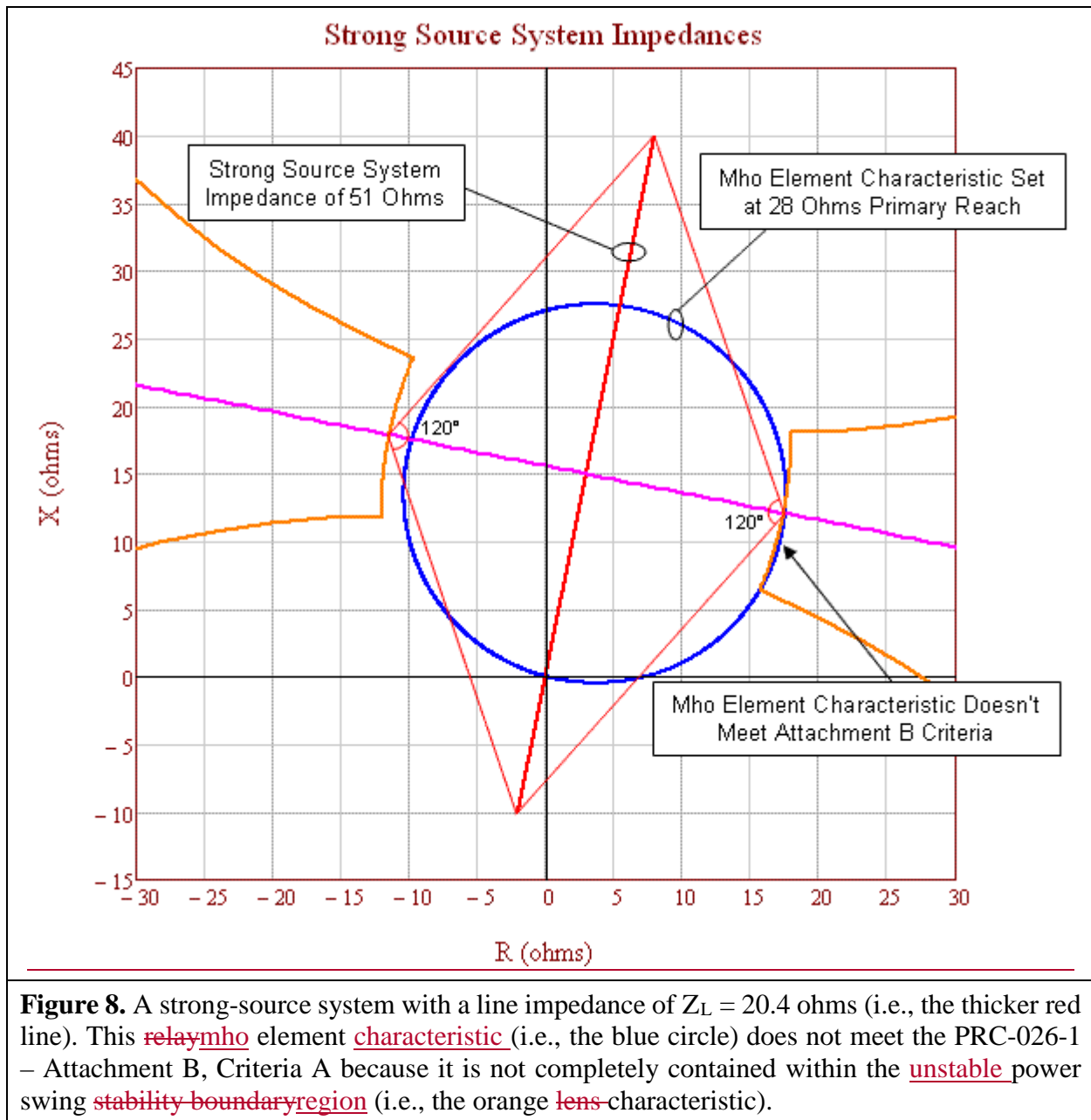
This example is for calculating the impedance sixth point of the lens characteristic. Unequal source voltages are used for the 230 kV (base) line with the receiving-end voltage ( $E_R$ ) at 70% of the sending-end voltage ( $E_S$ ) and the sending-end voltage leading the receiving-end voltage by 240 degrees. See Figures 43 and 54.

Eq. (46)	$E_S = \frac{V_{LL} \angle 240^\circ}{\sqrt{3}}$
	$E_S = \frac{230,000 \angle 240^\circ V}{\sqrt{3}}$
	$E_S = 132,791 \angle 240^\circ V$
Eq. (47)	$E_R = \frac{V_{LL} \angle 0^\circ}{\sqrt{3}} \times 70\%$
	$E_R = \frac{230,000 \angle 0^\circ V}{\sqrt{3}} \times 0.70$
	$E_R = 92,953.7 \angle 0^\circ V$
Given positive sequence impedance data (The transfer impedance $Z_{TR}$ is set to infinity).	
Given:	$Z_S = 2 + j10 \Omega$ $Z_L = 4 + j20 \Omega$ $Z_R = 4 + j20 \Omega$
Given:	$Z_{TR} = Z_L \times 10^{10} \Omega$
Total impedance between generators.	
Eq. (48)	$Z_{total} = \frac{(Z_L \times Z_{TR})}{(Z_L + Z_{TR})}$
	$Z_{total} = \frac{((4 + j20) \Omega \times (4 + j20)^{10} \Omega)}{((4 + j20) \Omega + (4 + j20)^{10} \Omega)}$
	$Z_{total} = 4 + j20 \Omega$
Total system impedance.	
Eq. (49)	$Z_{sys} = Z_S + Z_{total} + Z_R$
	$Z_{sys} = (2 + j10) \Omega + (4 + j20) \Omega + (4 + j20) \Omega$
	$Z_{sys} = 10 + j50 \Omega$

<b>Table 7. Example Calculation (Lens Point 6)</b>	
Total system current from sending- <u>end</u> source.	
Eq. (50)	$I_{sys} = \frac{E_S - E_R}{Z_{sys}}$
	$I_{sys} = \frac{132,791 \angle 240^\circ V - 92,953.7 \angle 0^\circ V}{10 + j50 \Omega}$
	$I_{sys} = 3,854 \angle 137.1^\circ A$
The current as measured by the relay on $Z_L$ is only the current flowing through that line as determined by using the current divider equation.	
Eq. (51)	$I_L = I_{sys} \times \frac{Z_{TR}}{Z_L + Z_{TR}}$
	$I_L = 3,854 \angle 137.1^\circ A \times \frac{(4 + j20)^{10} \Omega}{(4 + j20) \Omega + (4 + j20)^{10} \Omega}$
	$I_L = 3,854 \angle 137.1^\circ A$
The voltage as measured by the relay on $Z_L$ is the voltage drop from the sending- <u>end</u> source through the sending- <u>end</u> source impedance.	
Eq. (52)	$V_S = E_S - (Z_S \times I_L)$
	$V_S = 132,791 \angle 240^\circ V - [(2 + j10) \Omega \times 3,854 \angle 137.1^\circ A]$
	$V_S = 98,265 \angle -110.6^\circ V$
The impedance seen by the relay on $Z_L$ .	
Eq. (53)	$Z_{L-Relay} = \frac{V_S}{I_L}$
	$Z_{L-Relay} = \frac{98,265 \angle -110.6^\circ V}{3,854 \angle 137.1^\circ A}$
	$Z_{L-Relay} = -9.676 + j23.59 \Omega$

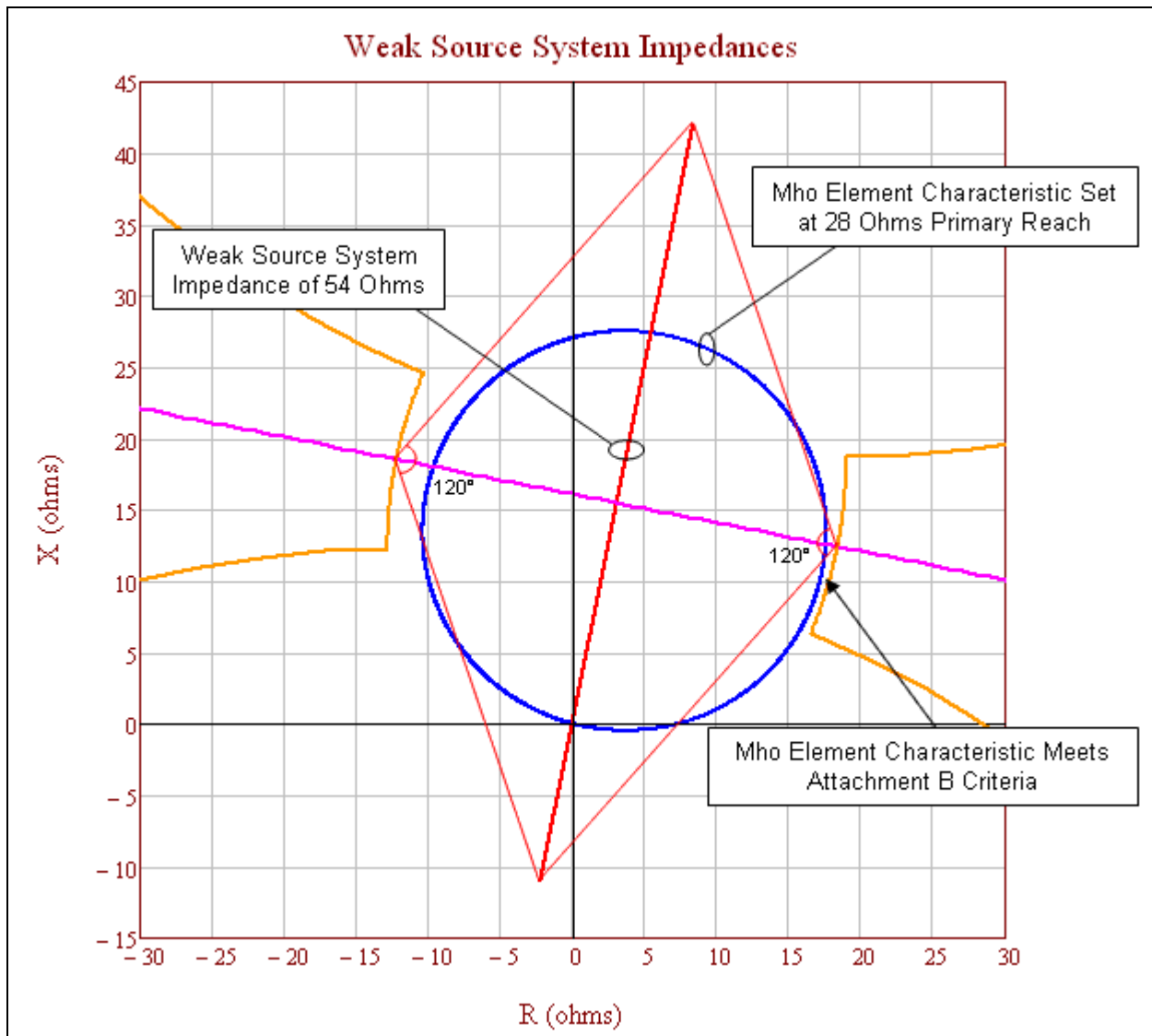






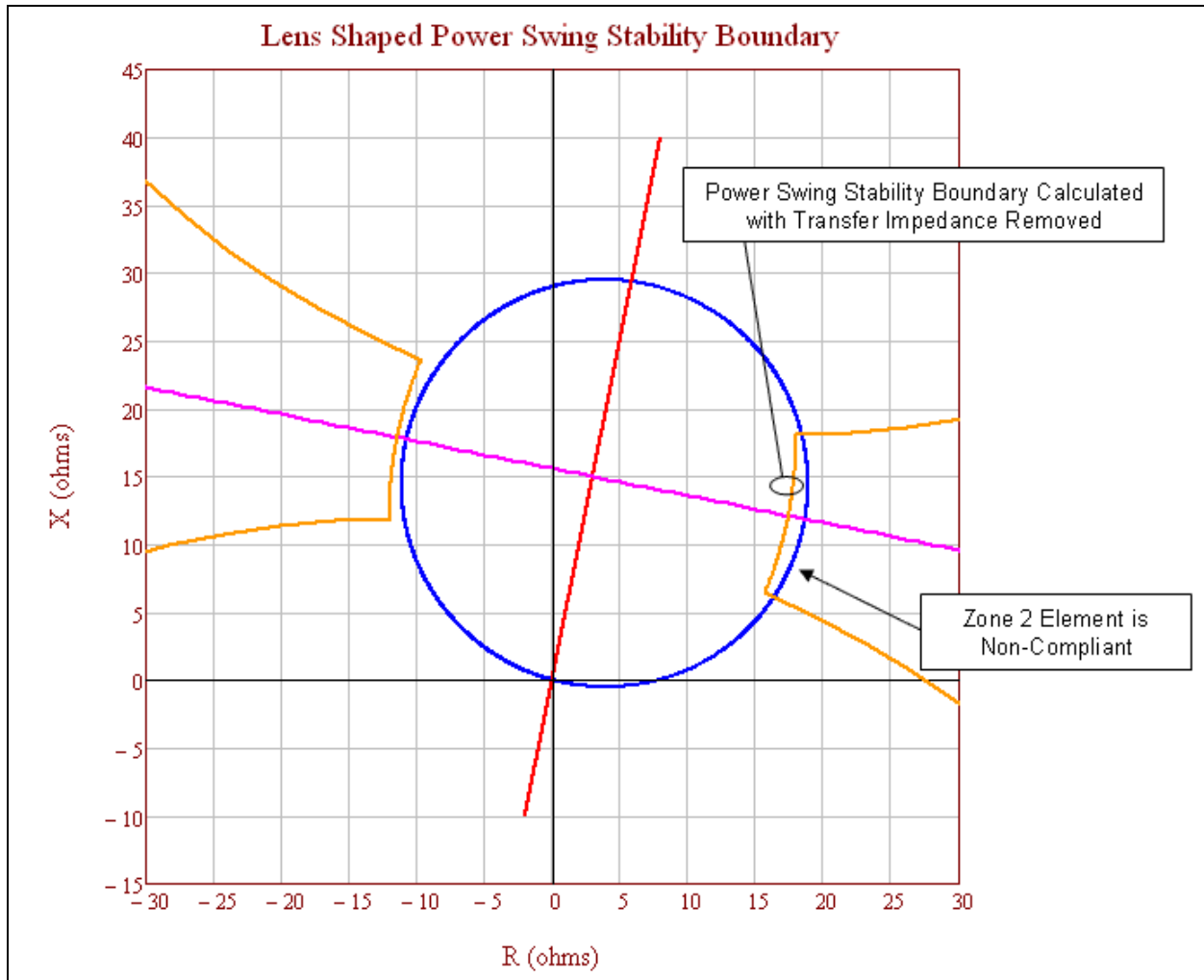
**Figure 8.** A strong-source system with a line impedance of  $Z_L = 20.4$  ohms (i.e., the thicker red line). This relay mho element characteristic (i.e., the blue circle) does not meet the PRC-026-1 – Attachment B, Criteria A because it is not completely contained within the unstable power swing stability boundary region (i.e., the orange lens-characteristic).

The figure above represents a heavily-heavy-loaded system using a maximum generation profile. The zone 2 mho element characteristic (set at 137% of  $Z_L$ ) extends into the unstable power swing stability boundary region (i.e., the orange partial lens-characteristic). Using the strongest source system is more conservative because it shrinks the unstable power swing stability boundary region, bringing it closer to the mho element characteristic. This figure also graphically represents the effect of a system strengthening over time and this is the reason for re-evaluation if the relay has not been evaluated in the last threefive calendar years. Figure 9 below depicts a relay that meets the PRC-026-1 – Attachment B, Criteria A. Figure 8 depicts the same relay with the same setting threefive years later, where each source has strengthened by about 10% and now the same zone 2 mho element characteristic does not meet Criteria A.

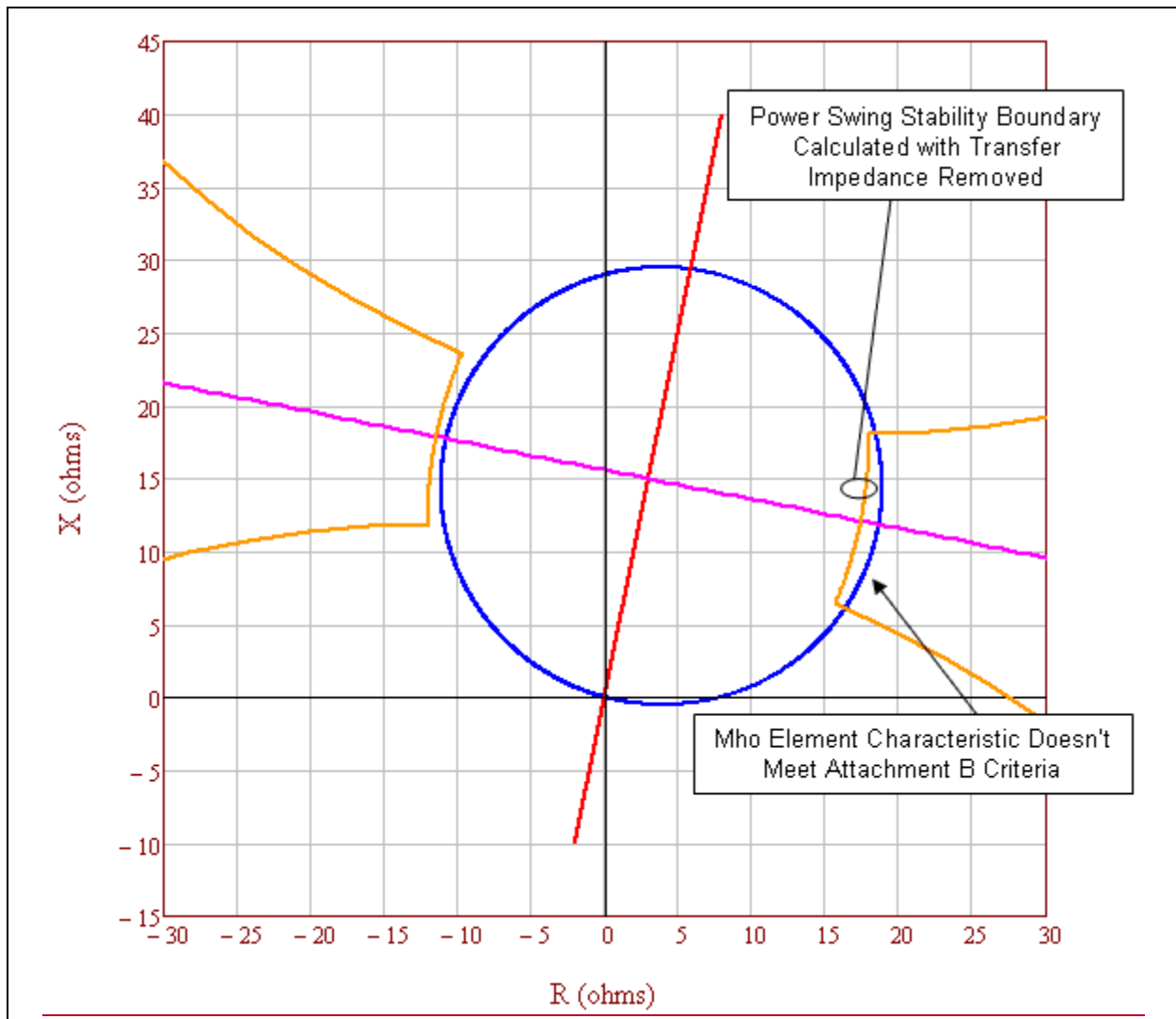


**Figure 9.** A weak-source system with a line impedance of  $Z_L = 20.4$  ohms (i.e., the thicker red line). This zone 2-mho element characteristic (i.e., the blue circle) meets the PRC-026-1 – Attachment B, Criteria A because it is completely contained within the unstable power swing stability boundary region (i.e., the orange lens-characteristic).

The figure above represents a lightly loaded system, using a minimum generation profile. The zone 2-mho element characteristic (set at 137% of  $Z_L$ ) does not extend into the unstable power swing stability boundary region (i.e., the orange lens-characteristic). Using a weaker source system expands the unstable power swing stability boundary region away from the mho element characteristic.







**Figure 10.** This is an example of an unstable power swing stability boundary region (i.e., the orange lens-characteristic) with the transfer impedance removed. This relay zone-2 mho element characteristic (i.e., the blue circle) does not meet PRC-026-1 – Attachment B, Criteria A because it is not completely contained within the unstable power swing stability boundary region.

**Table 8. Example Calculation (Transfer Impedance Removed)**

Calculations for the point at 120 degrees with equal source impedances. The total system current equals the line current. See Figure 10.

Eq. (54)	$E_S = \frac{V_{LL} \angle 120^\circ}{\sqrt{3}}$
	$E_S = \frac{230,000 \angle 120^\circ V}{\sqrt{3}}$

<b>Table 8. Example Calculation (Transfer Impedance Removed)</b>			
	$E_S = 132,791 \angle 120^\circ V$		
Eq. (55)	$E_R = \frac{V_{LL} \angle 0^\circ}{\sqrt{3}}$		
	$E_R = \frac{230,000 \angle 0^\circ V}{\sqrt{3}}$		
	$E_R = 132,791 \angle 0^\circ V$		
Given impedance data.			
Given:	$Z_S = 2 + j10 \Omega$	$Z_L = 4 + j20 \Omega$	$Z_R = 4 + j20 \Omega$
Given:	$Z_{TR} = Z_L \times 10^{10} \Omega$		
Total impedance between generators.			
Eq. (56)	$Z_{total} = \frac{(Z_L \times Z_{TR})}{(Z_L + Z_{TR})}$		
	$Z_{total} = \frac{(4 + j20) \Omega \times (4 + j20)^{10} \Omega}{(4 + j20) \Omega + (4 + j20)^{10} \Omega}$		
	$Z_{total} = 4 + j20 \Omega$		
Total system impedance.			
Eq. (57)	$Z_{sys} = Z_S + Z_{total} + Z_R$		
	$Z_{sys} = (2 + j10) \Omega + (4 + j20) \Omega + (4 + j20) \Omega$		
	$Z_{sys} = 10 + j50 \Omega$		
Total system current from sending- <del>end</del> source.			
Eq. (58)	$I_{sys} = \frac{E_S - E_R}{Z_{sys}}$		
	$I_{sys} = \frac{132,791 \angle 120^\circ V - 132,791 \angle 0^\circ V}{10 + j50 \Omega}$		
	$I_{sys} = 4,511 \angle 71.3^\circ A$		
The current as measured by the relay on $Z_L$ is only the current flowing through that line as determined by using the current divider equation.			
Eq. (59)	$I_L = I_{sys} \times \frac{Z_{TR}}{Z_L + Z_{TR}}$		
	$I_L = 4,511 \angle 71.3^\circ A \times \frac{(4 + j20)^{10} \Omega}{(4 + j20) \Omega + (4 + j20)^{10} \Omega}$		
	$I_L = 4,511 \angle 71.3^\circ A$		

**Table 8. Example Calculation (Transfer Impedance Removed)**

The voltage as measured by the relay on  $Z_L$  is the voltage drop from the sending-end source through the sending-end source impedance.

Eq. (60)  $V_S = E_S - (Z_S \times I_{sys})$

$$V_S = 132,791 \angle 120^\circ V - [(2 + j10 \Omega) \times 4,511 \angle 71.3^\circ A]$$

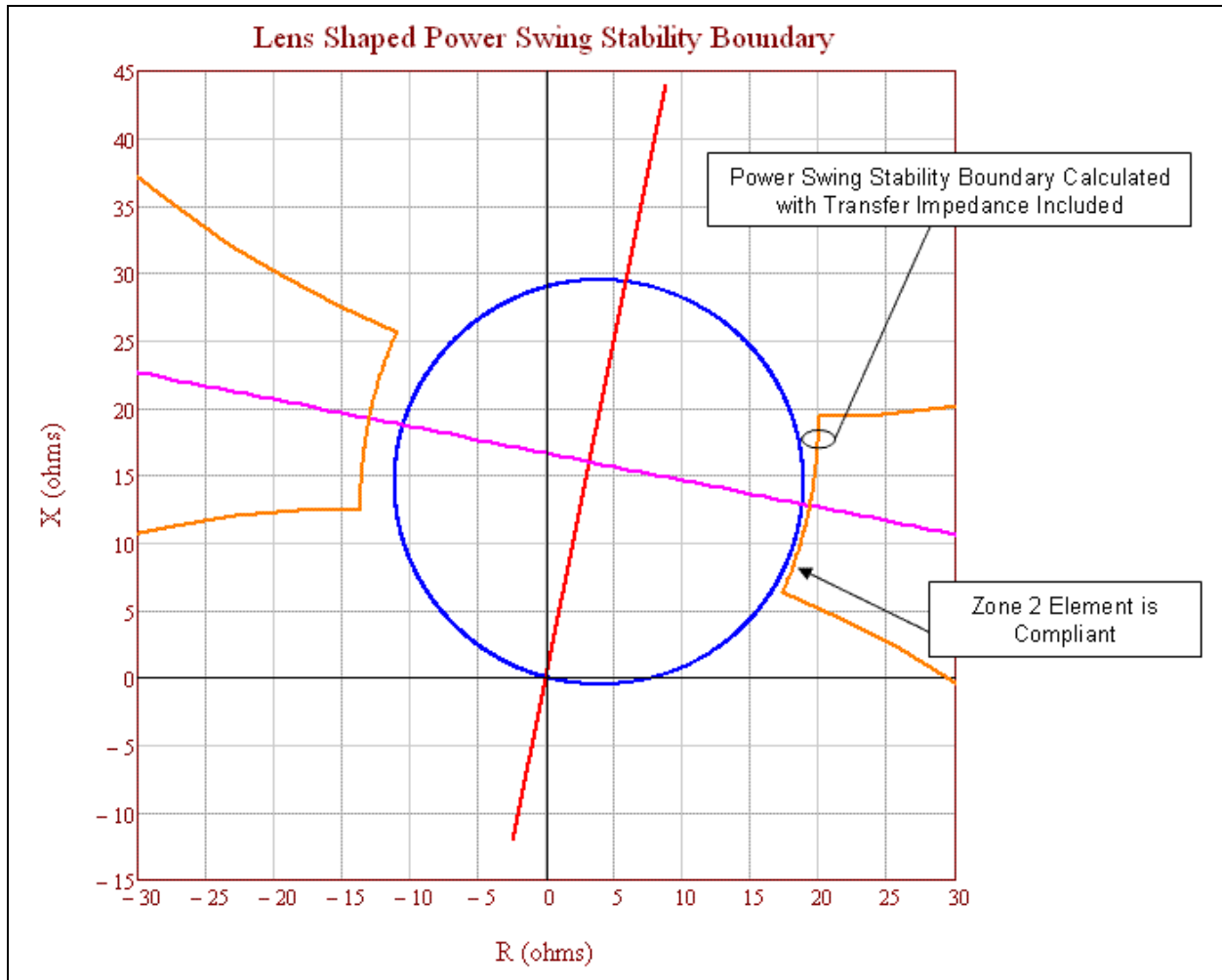
$$V_S = 95,757 \angle 106.1^\circ V$$

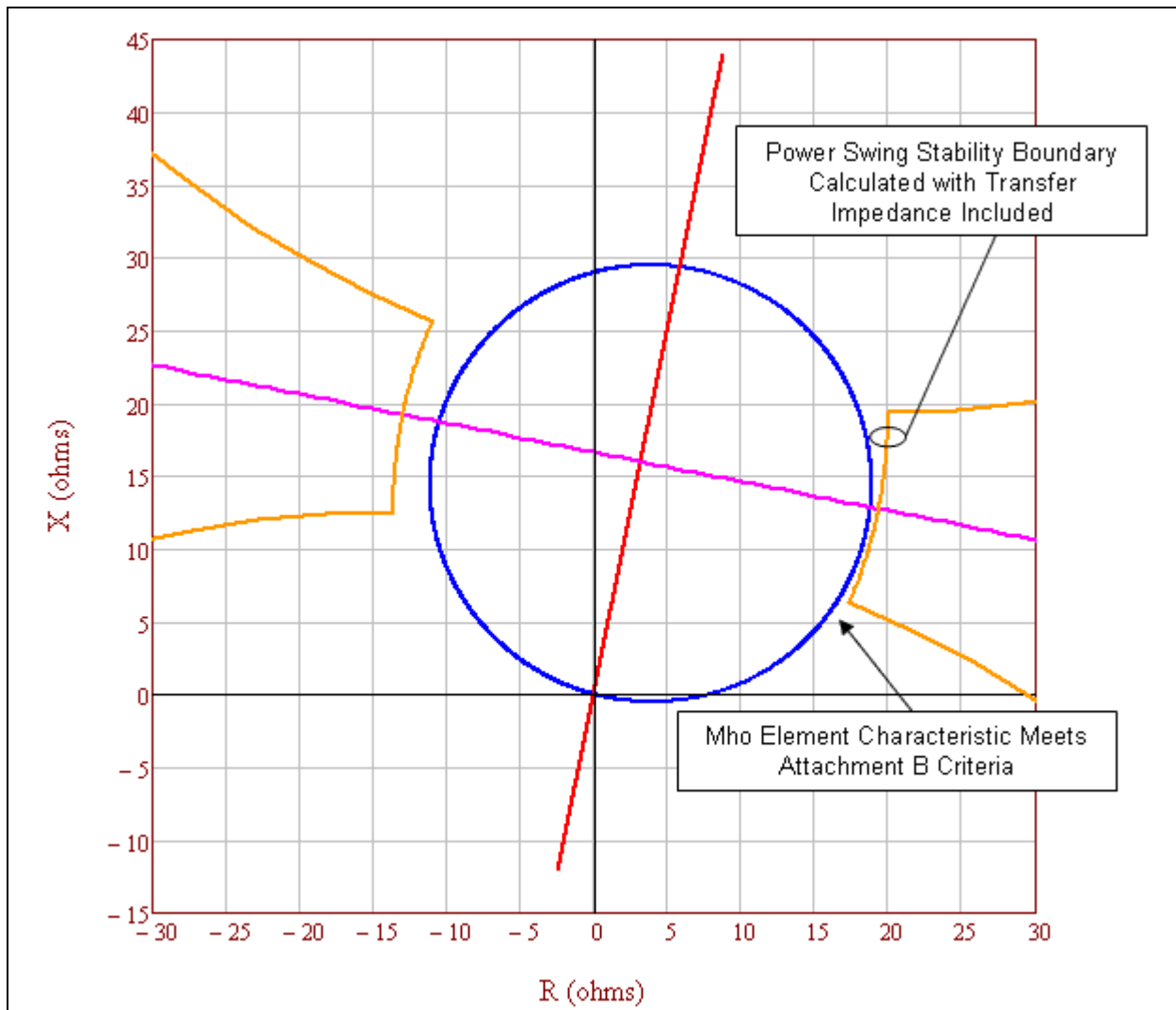
The impedance seen by the relay on  $Z_L$ .

Eq. (61)  $Z_{L-Relay} = \frac{V_S}{I_L}$

$$Z_{L-Relay} = \frac{95,757 \angle 106.1^\circ V}{4,511 \angle 71.3^\circ A}$$

$$Z_{L-Relay} = 17.434 + j12.113 \Omega$$





**Figure 11.** This is an example of ~~aan unstable~~ power swing ~~stability boundary region~~ (i.e., the orange ~~lens~~-characteristic) with the transfer impedance included. The ~~zone-2mho~~ element ~~characteristic~~ (i.e., the blue circle) meets the PRC-026-1 – Attachment B, Criteria A because it is completely contained within the ~~power swing stability boundary unstable power swing region~~. ~~However, including the transfer impedance in the calculation is not compliant with PRC-026-1 – Attachment B Criteria A.~~

In the figure above, the transfer impedance is 5 times the line impedance. The ~~lens~~ ~~characteristic unstable power swing region~~ has expanded out beyond the ~~zone-2mho~~ element ~~characteristic~~ due to the infeed effect from the parallel current through the transfer impedance, thus allowing the ~~zone-2mho~~ element ~~characteristic~~ to meet PRC-026-1 – Attachment B, Criteria A. ~~However, including the transfer impedance in the calculation is not compliant with PRC-026-1 – Attachment B Criteria A.~~

<b>Table 9. Example Calculation (Transfer Impedance Included)</b>			
Calculations for the point at 120 degrees with equal source impedances. The total system current does not equal the line current. See Figure 11.			
Eq. (62)	$E_S = \frac{V_{LL} \angle 120^\circ}{\sqrt{3}}$		
	$E_S = \frac{230,000 \angle 120^\circ V}{\sqrt{3}}$		
	$E_S = 132,791 \angle 120^\circ V$		
Eq. (63)	$E_R = \frac{V_{LL} \angle 0^\circ}{\sqrt{3}}$		
	$E_R = \frac{230,000 \angle 0^\circ V}{\sqrt{3}}$		
	$E_R = 132,791 \angle 0^\circ V$		
<b>Given impedance data.</b>			
Given:	$Z_S = 2 + j10 \Omega$	$Z_L = 4 + j20 \Omega$	$Z_R = 4 + j20 \Omega$
Given:	$Z_{TR} = Z_L \times 5$		
	$Z_{TR} = (4 + j20) \Omega \times 5$		
	$Z_{TR} = 20 + j100 \Omega$		
<b>Total impedance between generators.</b>			
Eq. (64)	$Z_{total} = \frac{(Z_L \times Z_{TR})}{(Z_L + Z_{TR})}$		
	$Z_{total} = \frac{(4 + j20) \Omega \times (20 + j100) \Omega}{(4 + j20) \Omega + (20 + j100) \Omega}$		
	$Z_{total} = 3.333 + j16.667 \Omega$		
<b>Total system impedance.</b>			
Eq. (65)	$Z_{sys} = Z_S + Z_{total} + Z_R$		
	$Z_{sys} = (2 + j10) \Omega + (3.333 + j16.667) \Omega + (4 + j20) \Omega$		
	$Z_{sys} = 9.333 + j46.667 \Omega$		
<b>Total system current from sending-<u>end</u> source.</b>			
Eq. (66)	$I_{sys} = \frac{E_S - E_R}{Z_{sys}}$		
	$I_{sys} = \frac{132,791 \angle 120^\circ V - 132,791 \angle 0^\circ V}{9.333 + j46.667 \Omega}$		

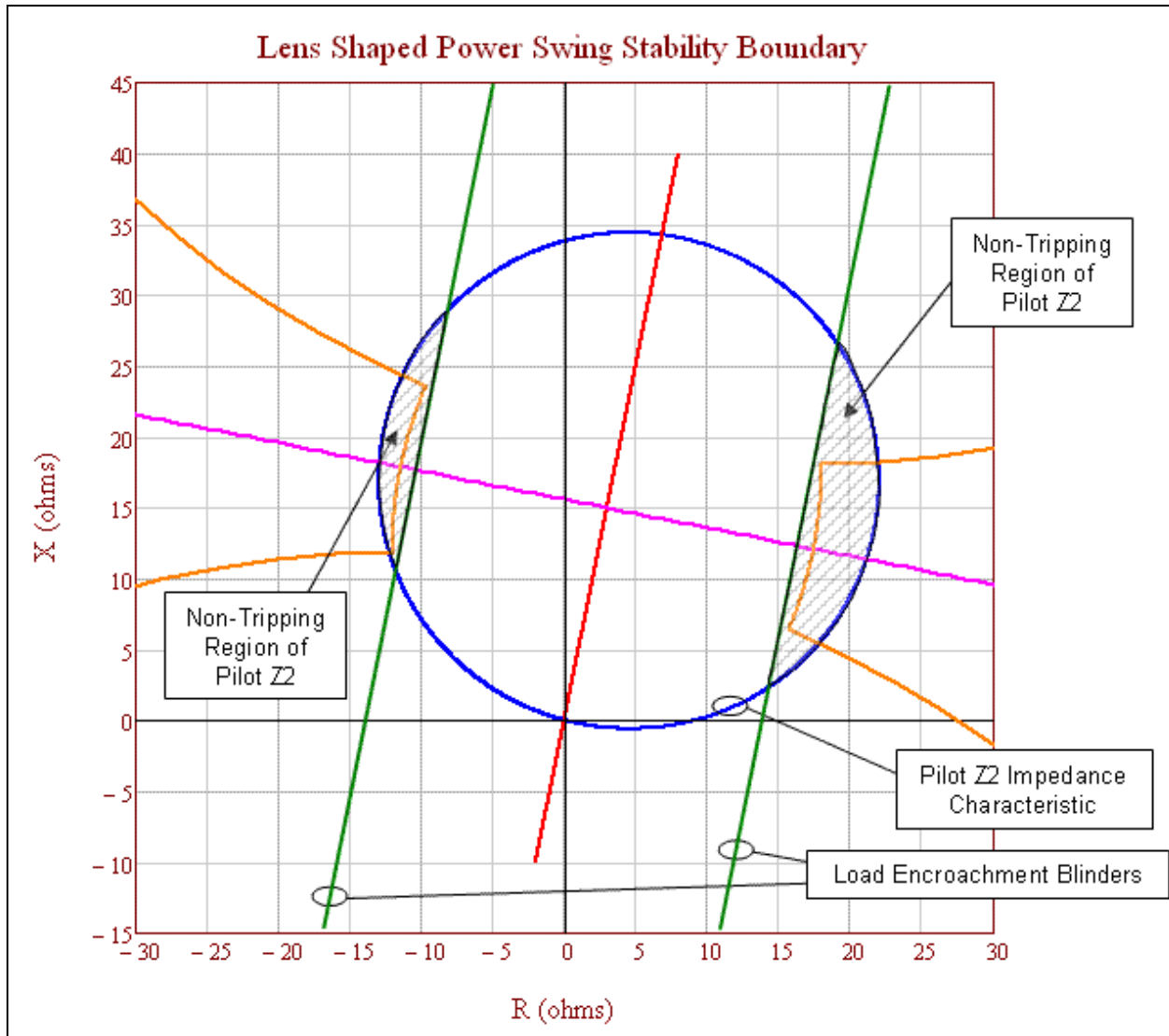
Table 9. Example Calculation (Transfer Impedance Included)	
	$I_{sys} = 4,832 \angle 71.3^\circ A$
The current as measured by the relay on $Z_L$ is only the current flowing through that line as determined by using the current divider equation.	
Eq. (67)	$I_L = I_{sys} \times \frac{Z_{TR}}{Z_L + Z_{TR}}$
	$I_L = 4,832 \angle 71.3^\circ A \times \frac{(20 + j100) \Omega}{(9.333 + j46.667) \Omega + (20 + j100) \Omega}$
	$I_L = 4,027.4 \angle 71.3^\circ A$
The voltage as measured by the relay on $Z_L$ is the voltage drop from the sending- <u>end</u> source through the sending- <u>end</u> source impedance.	
Eq. (68)	$V_S = E_S - (Z_S \times I_{sys})$
	$V_S = 132,791 \angle 120^\circ V - [(2 + j10 \Omega) \times 4,027 \angle 71.3^\circ A]$
	$V_S = 93,417 \angle 104.7^\circ V$
The impedance seen by the relay on $Z_L$ .	
Eq. (69)	$Z_{L-Relay} = \frac{V_S}{I_L}$
	$Z_{L-Relay} = \frac{93,417 \angle 104.7^\circ V}{4,027 \angle 71.3^\circ A}$
	$Z_{L-Relay} = 19.366 + j12.767 \Omega$

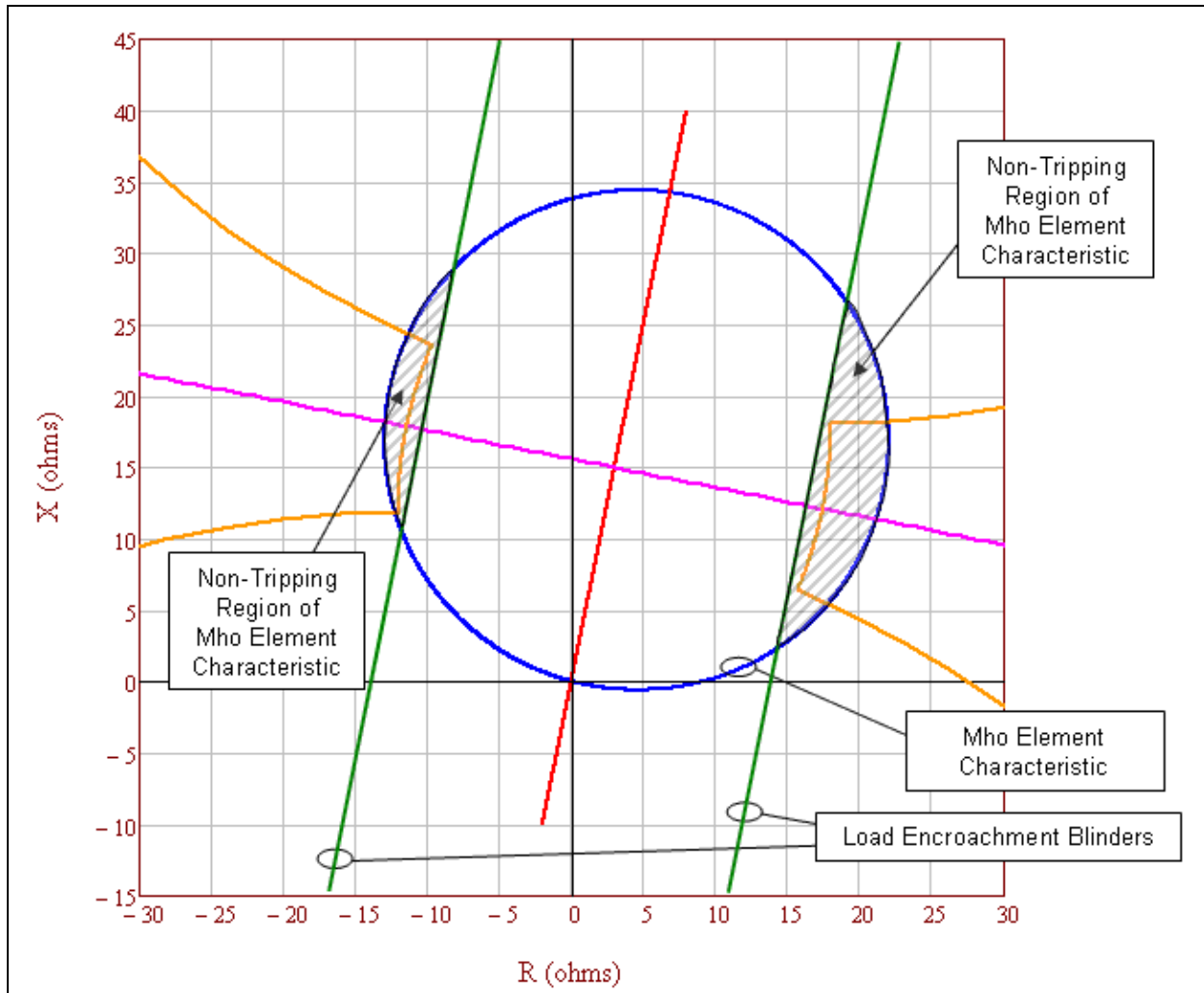
**Table 10. Percent Increase of a Lens Due To Parallel Transfer Impedance.**

The following demonstrates the percent size increase of the lens characteristic for  $Z_{TR}$  in multiples of  $Z_L$  with the transfer impedance included.

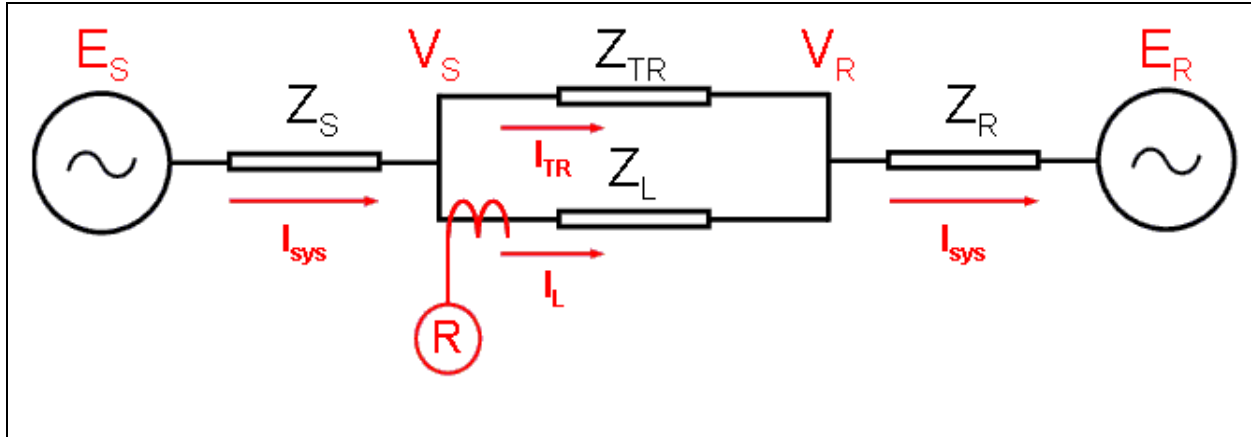
$Z_{TR}$ in multiples of $Z_L$	Percent increase of lens with equal EMF sources (Infinite source as reference)
Infinite	N/A
1000	0.05%
100	0.46%
10	4.63%
5	9.27%
2	23.26%
1	46.76%
0.5	94.14%
0.25	189.56%







**Figure 12.** The tripping portion not blocked by load encroachment (i.e., the parallel green lines) of the pilot zone 2mho element characteristic (i.e., the blue circle) is completely contained within the unstable power swing stability boundary region (i.e., the orange lens-characteristic). Therefore, the zone 2mho element characteristic meets the PRC-026-1 – Attachment B, Criteria A.



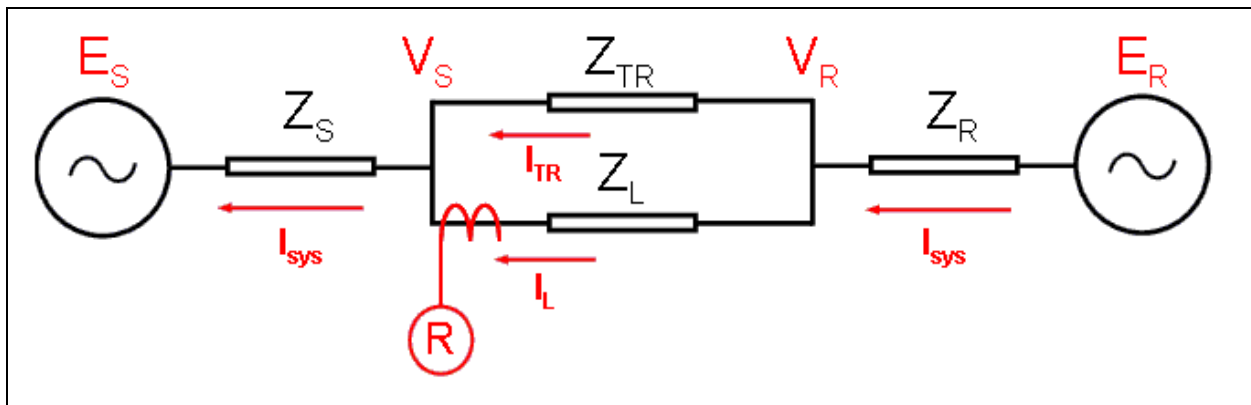
**Figure 13:** The infeed diagram shows the impedance in front of the relay R with the parallel transfer impedance included. As the parallel transfer impedance approaches infinity, the impedances seen by the relay R in the forward direction becomes  $Z_L + Z_R$ .

**Table 11. Calculations (System Apparent Impedance in the forward direction)**

The following equations are provided for calculating the apparent impedance back to the  $E_R$  source voltage as seen by relay R. Infeed equations from  $V_S$  to source  $E_R$  where  $E_R = 0$ . See Figure 13.

Eq. (70)	$I_L = \frac{V_S - V_R}{Z_L}$			
Eq. (71)	$I_{sys} = \frac{V_R - E_R}{Z_R}$			
Eq. (72)	$I_{sys} = I_L + I_{TR}$			
Eq. (73)	$I_{sys} = \frac{V_R}{Z_R}$	Since $E_R = 0$	Rearranged:	$V_R = I_{sys} \times Z_R$
Eq. (74)	$I_L = \frac{V_S - I_{sys} \times Z_R}{Z_L}$			
Eq. (75)	$I_L = \frac{V_S - [(I_L + I_{TR}) \times Z_R]}{Z_L}$			
Eq. (76)	$V_S = (I_L \times Z_L) + (I_L \times Z_R) + (I_{TR} \times Z_R)$			
Eq. (77)	$Z_{Relay} = \frac{V_S}{I_L} = Z_L + Z_R + \frac{I_{TR} \times Z_R}{I_L} = Z_L + Z_R \times \left(1 + \frac{I_{TR}}{I_L}\right)$			
Eq. (78)	$I_{TR} = I_{sys} \times \frac{Z_L}{Z_L + Z_{TR}}$			

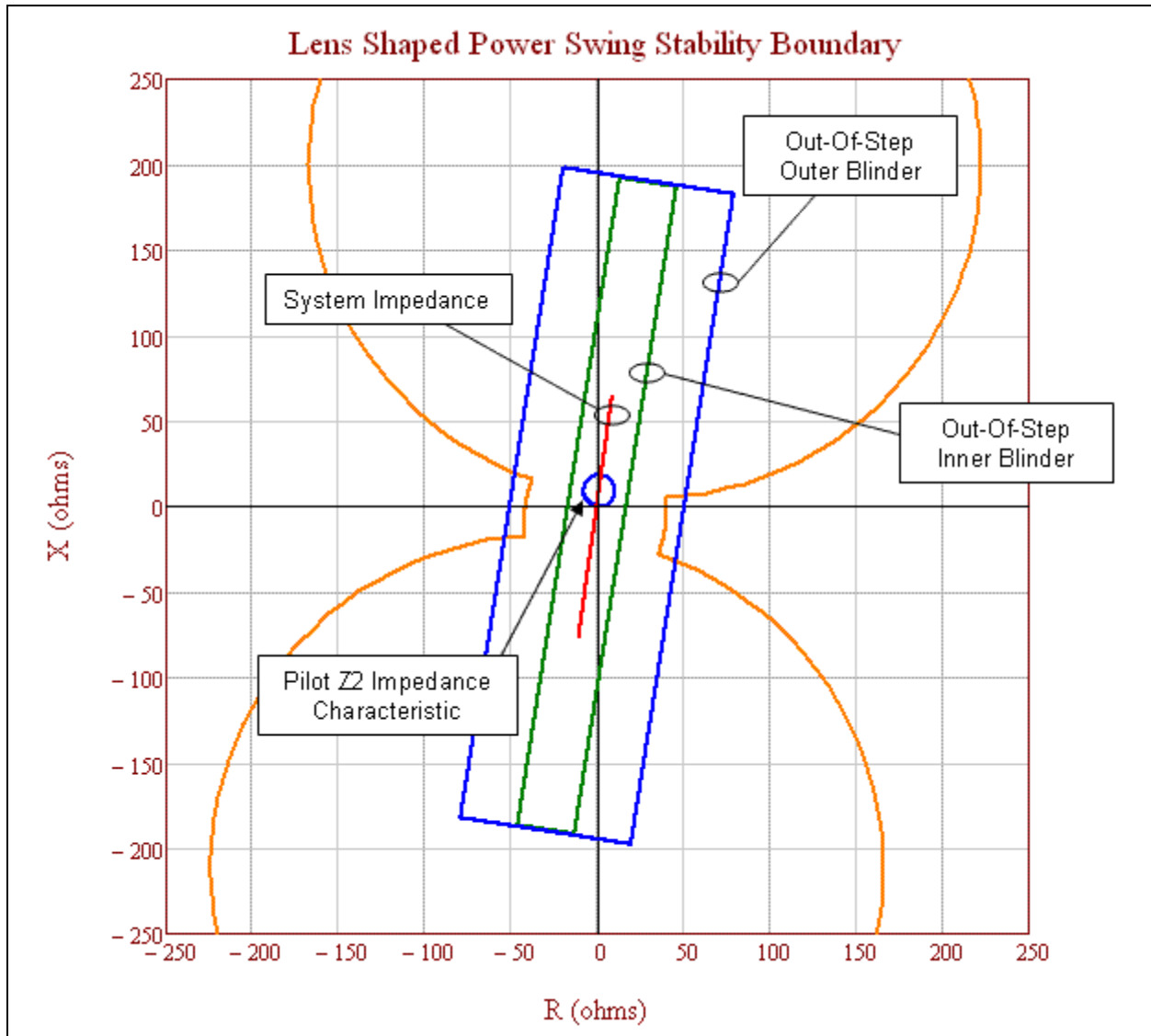
Table 11. Calculations (System Apparent Impedance in the forward direction)	
Eq. (79)	$I_L = I_{sys} \times \frac{Z_{TR}}{Z_L + Z_{TR}}$
Eq. (80)	$\frac{I_{TR}}{I_L} = \frac{Z_L}{Z_{TR}}$
The infeed equations shows the impedance in front of the relay R with the parallel transfer impedance included. As the parallel transfer impedance approaches infinity, the impedances seen by the relay R in the forward direction becomes $Z_L + Z_R$ .	
Eq. (81)	$Z_{Relay} = Z_L + Z_R \times \left(1 + \frac{Z_L}{Z_{TR}}\right)$

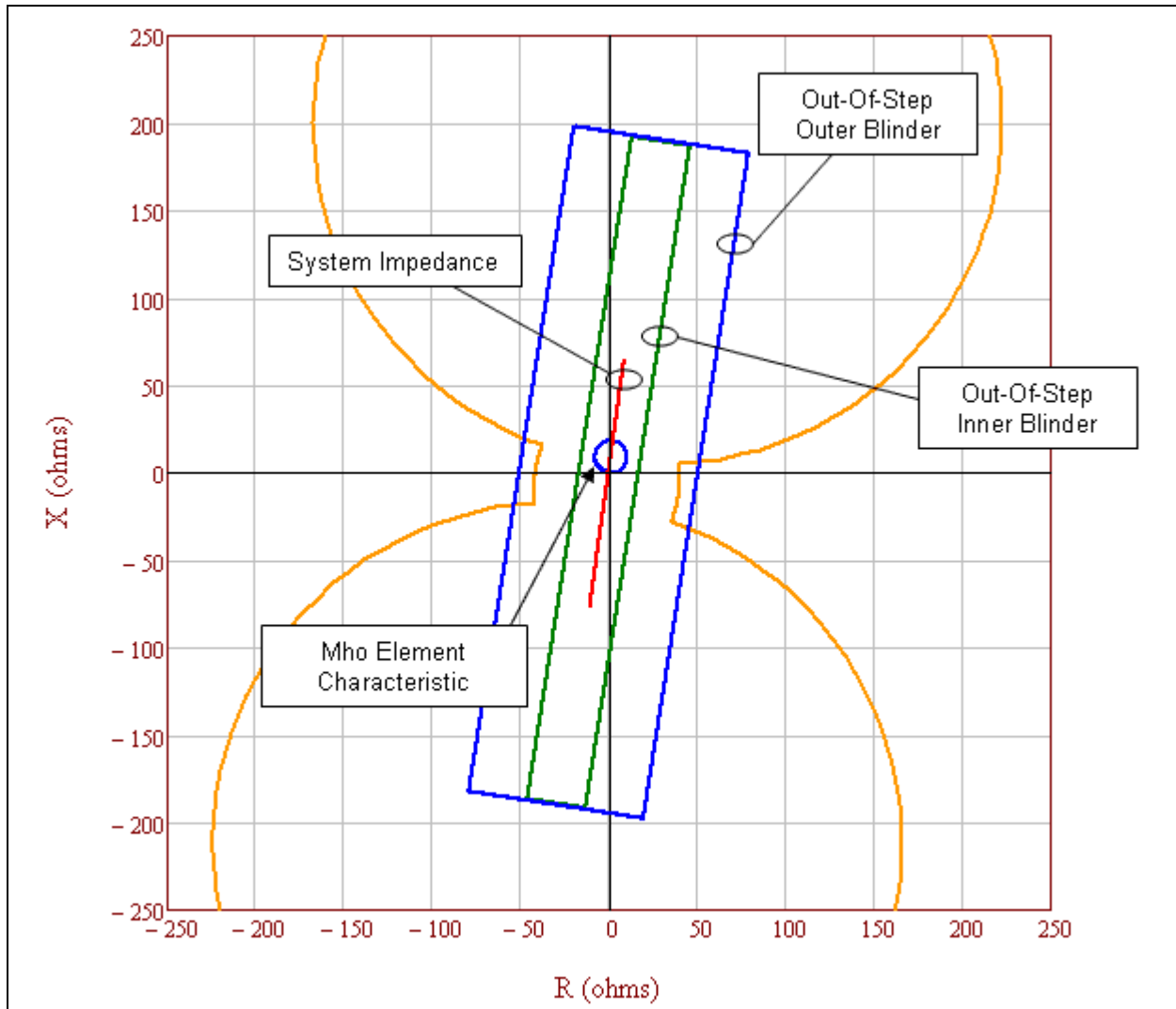


**Figure 14:** The infeed diagram shows the impedance behind relay R with the parallel transfer impedance included. As the parallel transfer impedance approaches infinity, the impedances seen by the relay R in the reverse direction becomes  $Z_S$ .

Table 12. Calculations (System Apparent Impedance in the reverse direction)			
The following equations are provided for calculating the apparent impedance back to the $E_S$ source voltage as seen by relay R. Infeed equations from $V_R$ back to source $E_S$ where $E_S = 0$ . See Figure 14.			
Eq. (82)	$I_L = \frac{V_R - V_S}{Z_L}$		
Eq. (83)	$I_{sys} = \frac{V_S - E_S}{Z_S}$		
Eq. (84)	$I_{sys} = I_L + I_{TR}$		
Eq. (85)	$I_{sys} = \frac{V_S}{Z_S}$	Since $E_S = 0$	Rearranged: $V_S = I_{sys} \times Z_S$

<b>Table 12. Calculations (System Apparent Impedance in the reverse direction)</b>		
Eq. (86)	$I_L = \frac{V_R - I_{sys} \times Z_S}{Z_L}$	
Eq. (87)	$I_L = \frac{V_R - [(I_L + I_{TR}) \times Z_S]}{Z_L}$	
Eq. (88)	$V_R = (I_L \times Z_L) + (I_L \times Z_S) + (I_{TR} \times Z_{RS})$	
Eq. (89)	$Z_{Relay} = \frac{V_R}{I_L} = Z_L + Z_S + \frac{I_{TR} \times Z_S}{I_L} = Z_L + Z_S \times \left(1 + \frac{I_{TR}}{I_L}\right)$	
Eq. (90)	$I_{TR} = I_{sys} \times \frac{Z_L}{Z_L + Z_{TR}}$	
Eq. (91)	$I_L = I_{sys} \times \frac{Z_{TR}}{Z_L + Z_{TR}}$	
Eq. (92)	$\frac{I_{TR}}{I_L} = \frac{Z_L}{Z_{TR}}$	
The infeed equations shows the impedance behind relay R with the parallel transfer impedance included. As the parallel transfer impedance approaches infinity, the impedances seen by the relay R in the reverse direction becomes $Z_S$ .		
Eq. (93)	$Z_{Relay} = Z_L + Z_S \times \left(1 + \frac{Z_L}{Z_{TR}}\right)$	As seen by relay R at the receiving-end of the line.
Eq. (94)	$Z_{Relay} = Z_S \times \left(1 + \frac{Z_L}{Z_{TR}}\right)$	Subtract $Z_L$ for relay R impedance as seen at sending-end of the line.





**Figure 15.** Out-of-step trip (OST) inner blinder (i.e., the parallel green lines) meets the PRC-026-1 – Attachment B, Criteria A because the inner OST blinder initiates tripping either On-The-Way-In or On-The-Way-Out. Since the inner blinder is completely contained within the ~~portion of the unstable~~ power swing stability boundary region (i.e., the orange lens characteristic), ~~the zone 2 element (i.e., the blue circle)~~ it meets the PRC-026-1 – Attachment B, Criteria A.

**Table 13. Example Calculation (Voltage Ratios)**

These calculations are based on the loss of synchronism characteristics for the cases of  $N < 1$  and  $N > 1$  as found in the *Application of Out-of-Step Blocking and Tripping Relays*, GER-3180, p. 12, Figure 31.<sup>15</sup> The GE illustration shows the formulae used to calculate the radius and center of the circles that make up the ends of the portion of the lens.

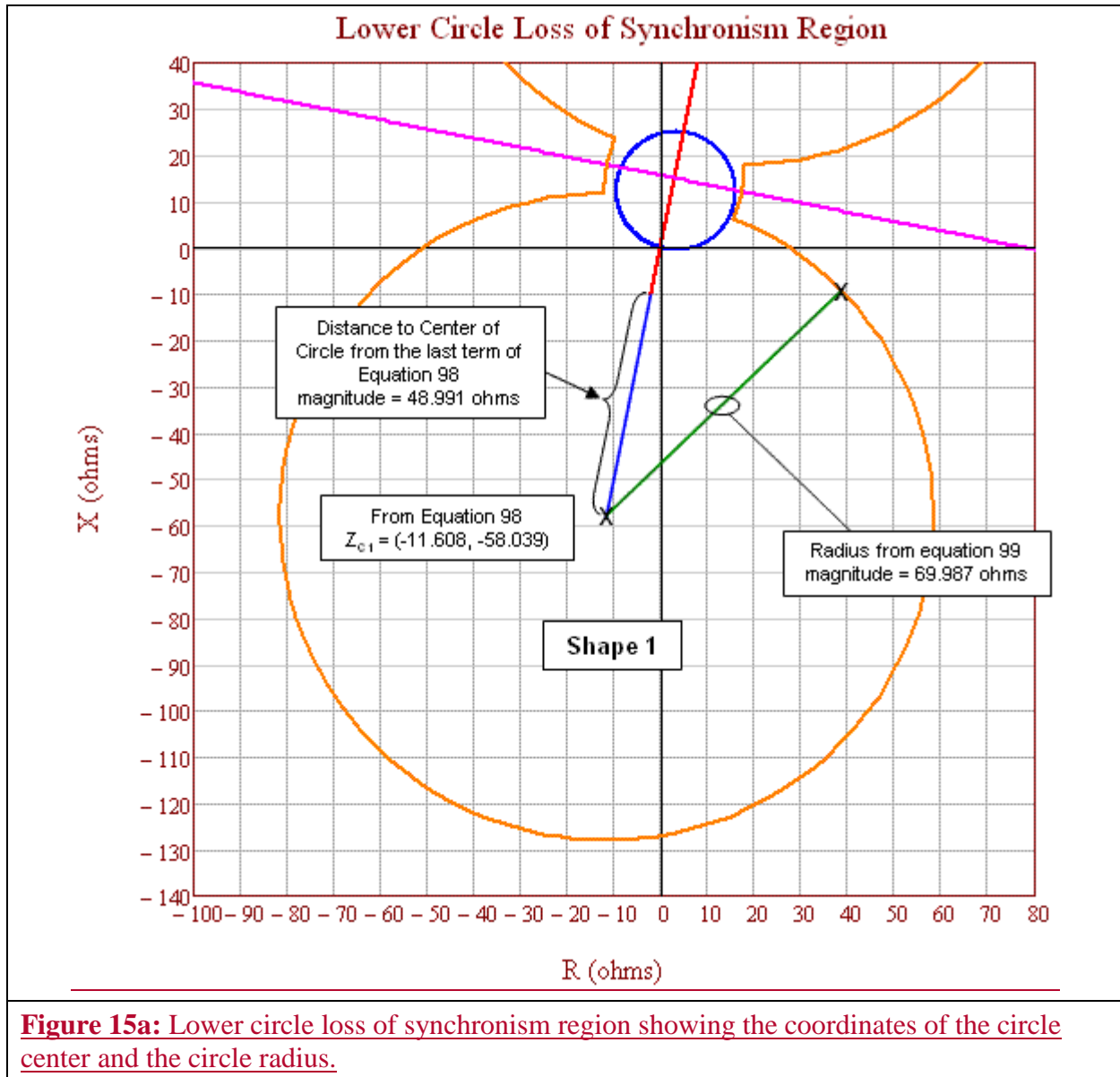
Voltage ratio equations, source impedance equation with infeed formulae applied, and circle equations.

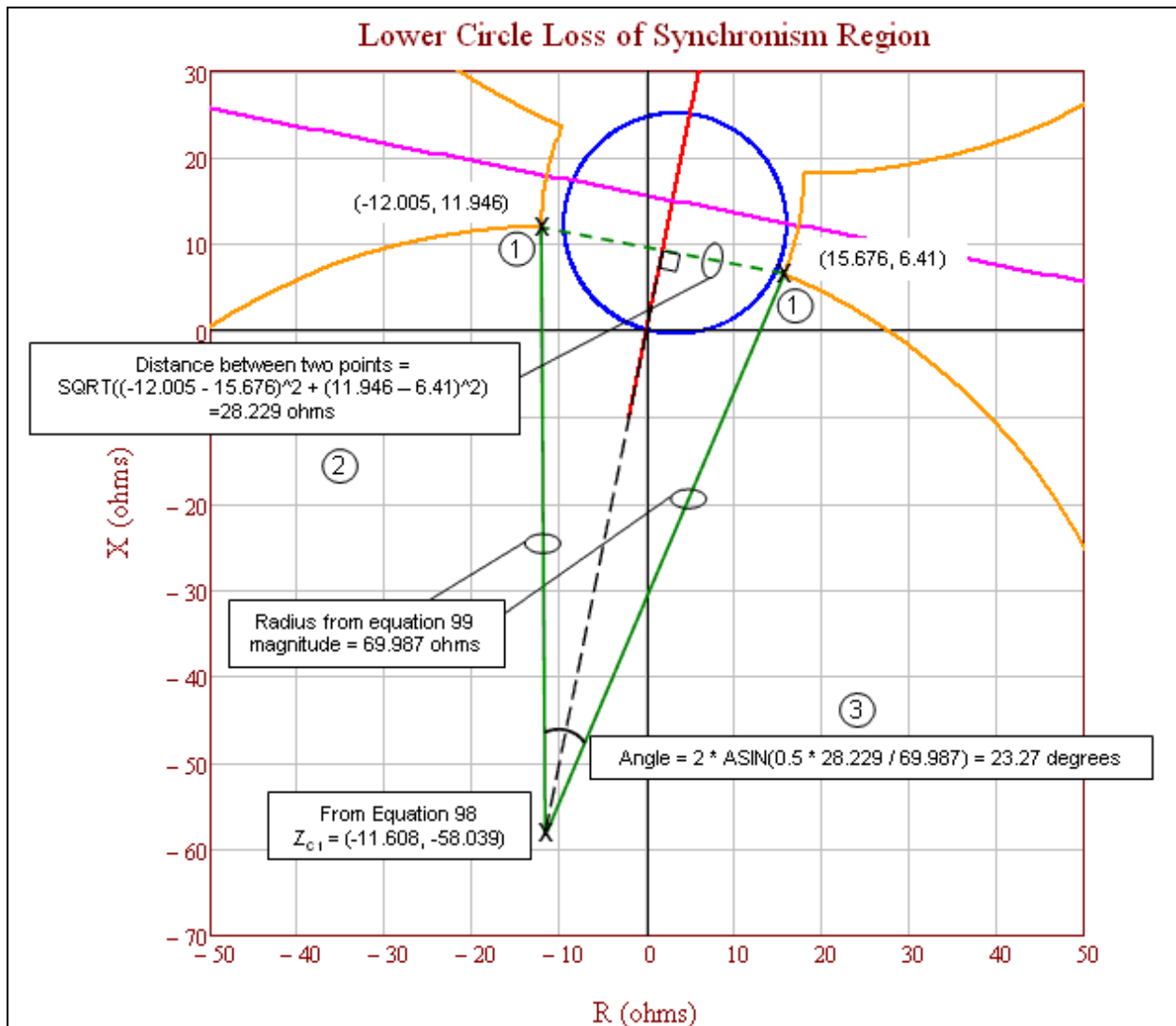
Given:	$E_S = 0.7$	$E_R = 1.0$
Eq. (95)	$N_a = \frac{ E_S }{ E_R } = \frac{0.7}{1.0} = 0.7$	
Eq. (96)	$N_b = \frac{ E_R }{ E_S } = \frac{1.0}{0.7} = 1.43$	
The total system impedance as seen by the relay with infeed formulae applied.		
Given:	$Z_S = 2 + j10 \Omega$	$Z_L = 4 + j20 \Omega$ $Z_R = 4 + j20 \Omega$
Given:	$Z_{TR} = Z_L \times 10^{10} \Omega$	
	$Z_{TR} = (4 + j20)^{10} \Omega$	
Eq. (97)	$Z_{sys} = Z_S \times \left(1 + \frac{Z_L}{Z_{TR}}\right) + \left[Z_L + Z_R \times \left(1 + \frac{Z_L}{Z_{TR}}\right)\right]$	
	$Z_{sys} = 10 + j50 \Omega$	
The calculated coordinates of the lower circle center.		
Eq. (98)	$Z_{C1} = - \left[ Z_S \times \left(1 + \frac{Z_L}{Z_{TR}}\right) \right] - \left[ \frac{N_a^2 \times Z_{sys}}{1 - N_a^2} \right]$	
	$Z_{C1} = - \left[ (2 + j10) \Omega \times \left(1 + \frac{(4 + j20) \Omega}{(4 + j20)^{10} \Omega}\right) \right] - \left[ \frac{0.7^2 \times (10 + j50) \Omega}{1 - 0.7^2} \right]$	
	$Z_{C1} = -11.608 - j58.039 \Omega$	
The calculated radius of the lower circle.		
Eq. (99)	$r_a = \left[ \frac{N_a \times Z_{sys}}{1 - N_a^2} \right]$	
	$r_a = \left[ \frac{0.7 \times (10 + j50) \Omega}{1 - 0.7^2} \right]$	
	$r_a = 69.987 \Omega$	

<sup>15</sup> <http://store.gedigitalenergy.com/faq/Documents/Alps/GER-3180.pdf>

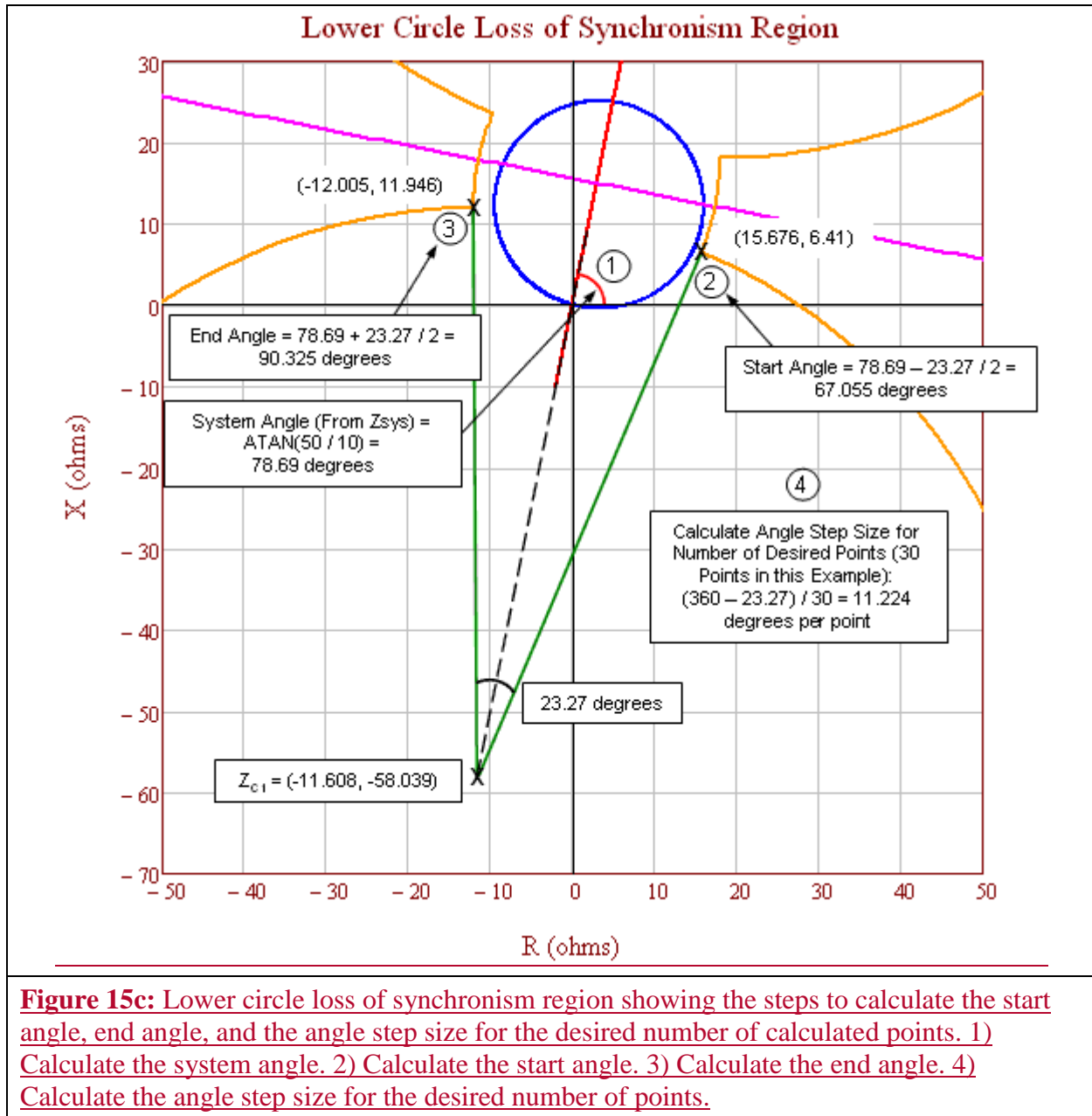


<b>Table 13. Example Calculation (Voltage Ratios)</b>	
The calculated coordinates of the upper circle center.	
Eq. (100)	$Z_{C2} = Z_L + \left[ Z_R \times \left( 1 + \frac{Z_L}{Z_{TR}} \right) \right] + \left[ \frac{Z_{sys}}{N_b^2 - 1} \right]$
	$Z_{C2} = - \left[ (4 + j20) \Omega \times \left( 1 + \frac{(4 + j20) \Omega}{(4 + j20)^{10} \Omega} \right) \right] + \left[ \frac{(10 + j50) \Omega}{1.43^2 - 1} \right]$
	$Z_{C2} = 17.608 + j88.039 \Omega$
The calculated radius of the upper circle.	
Eq. (101)	$r_b = \left[ \frac{N_b \times Z_{sys}}{N_b^2 - 1} \right]$
	$r_b = \left[ \frac{1.43 \times (10 + j50) \Omega}{1.43^2 - 1} \right]$
	$r_b = 69.987 \Omega$

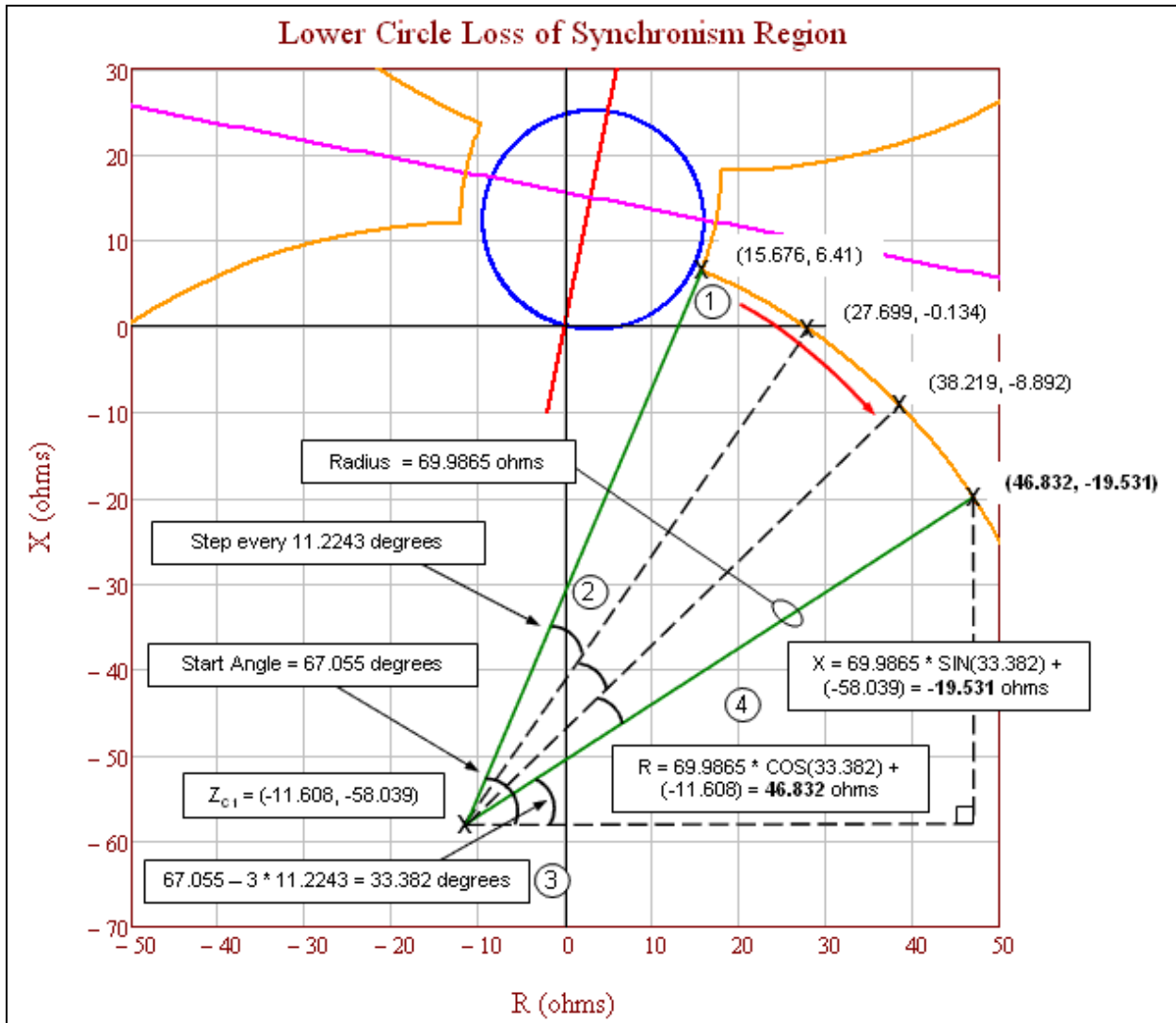




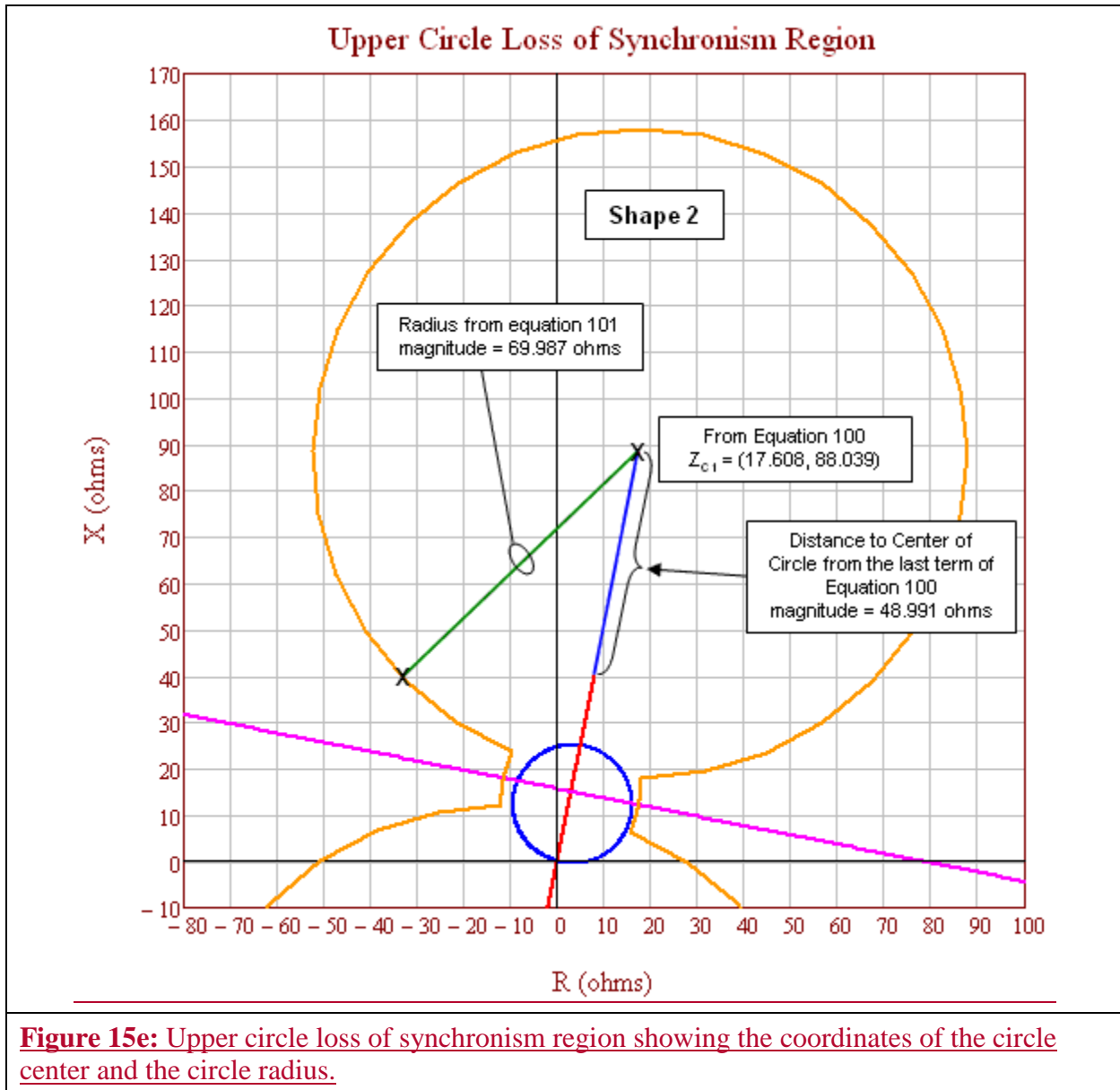
**Figure 15b:** Lower circle loss of synchronism region showing the first steps to calculate the coordinates of the points on the circle. 1) Identify the lower circle points that intersect the lens shape where the sending-end to receiving-end voltage ratio is 0.7 (see lens shape calculations in Tables 2-7). 2) Calculate the distance between the two lower circle points identified in Step 1. 3) Calculate the angle of arc that connects the two lower circle points identified in Step 1.

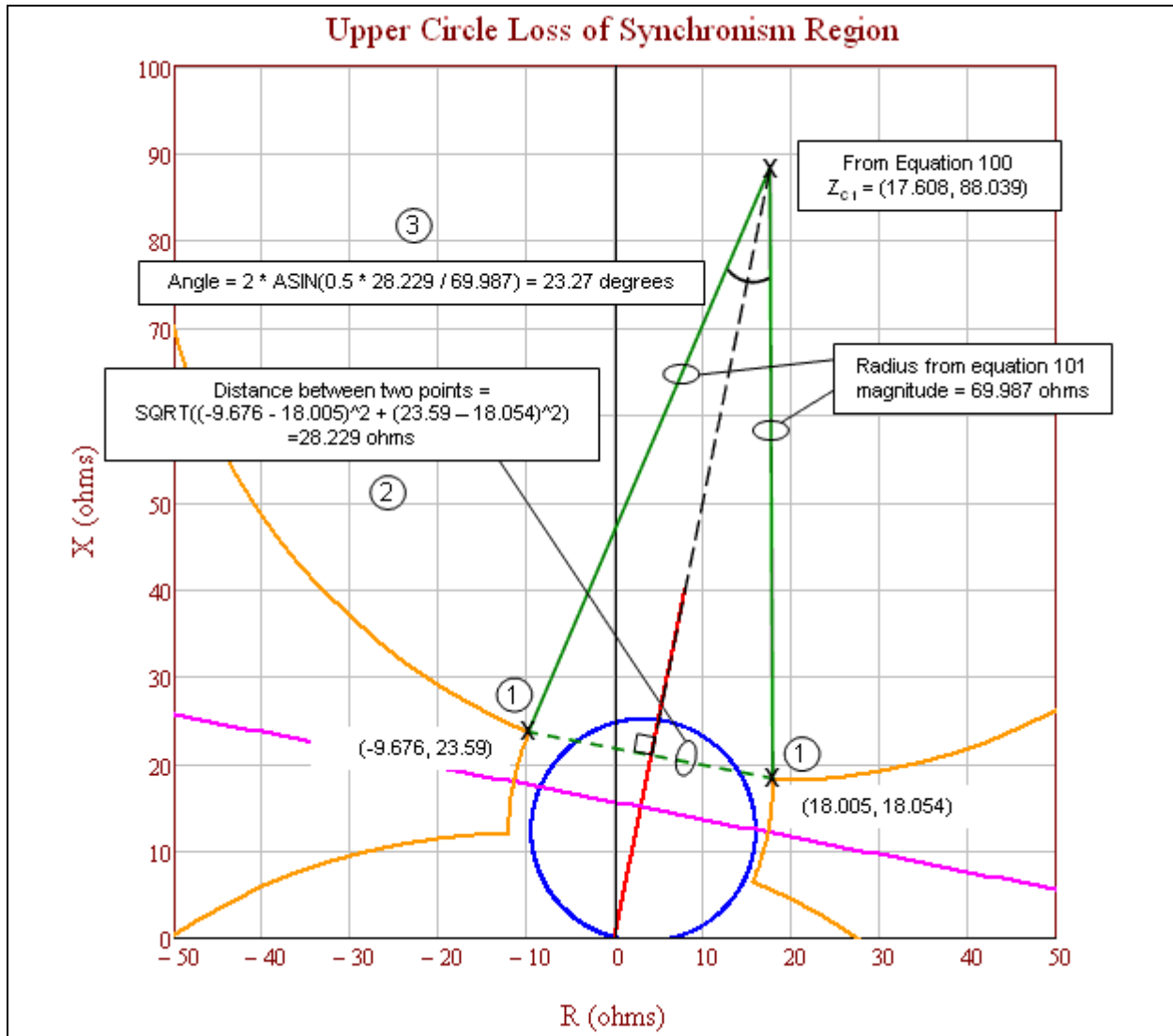


**Figure 15c:** Lower circle loss of synchronism region showing the steps to calculate the start angle, end angle, and the angle step size for the desired number of calculated points. 1) Calculate the system angle. 2) Calculate the start angle. 3) Calculate the end angle. 4) Calculate the angle step size for the desired number of points.

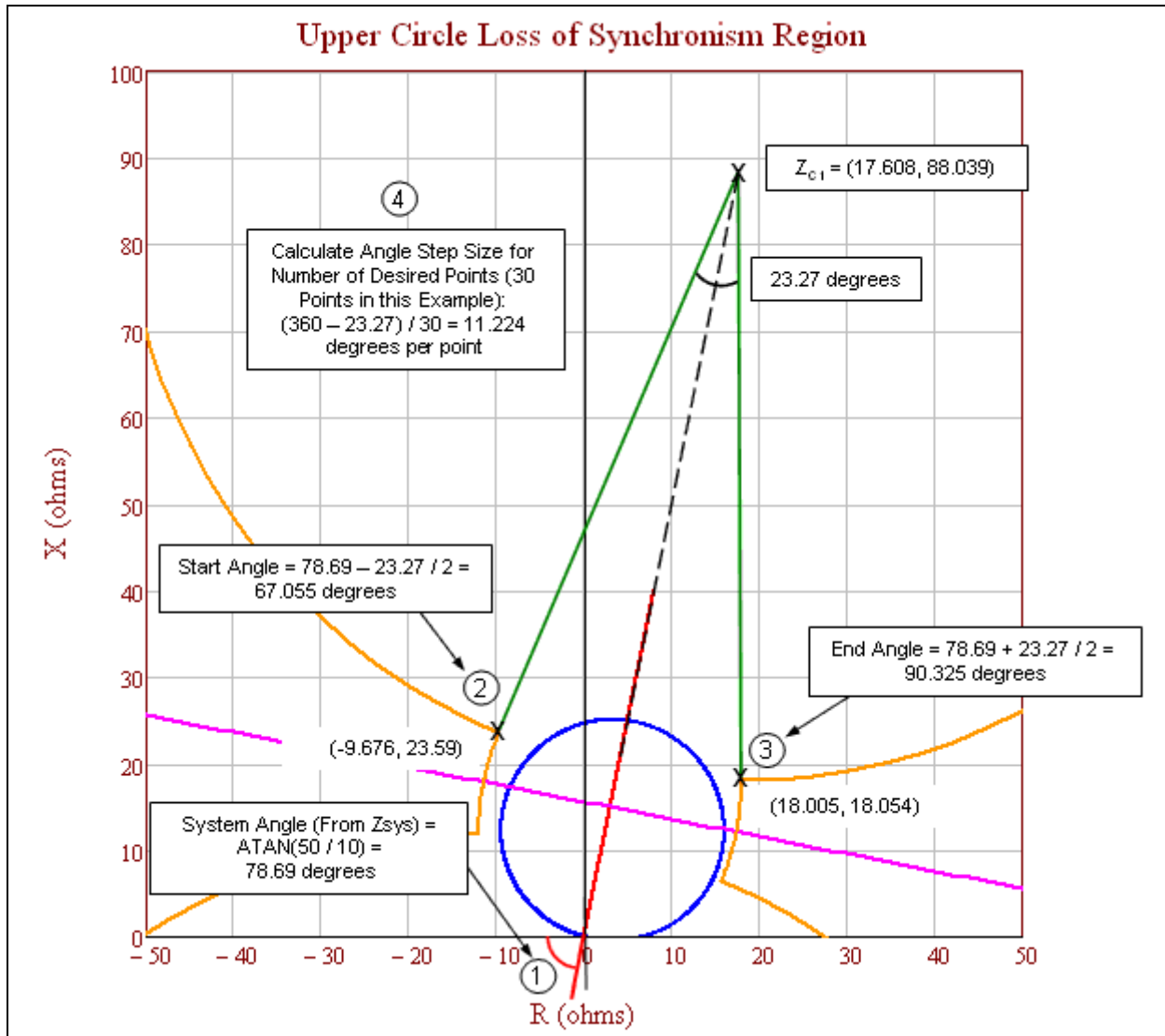


**Figure 15d:** Lower circle loss of synchronism region showing the final steps to calculate the coordinates of the points on the circle. 1) Start at the intersection with the lens shape and proceed in a clockwise direction. 2) Advance the step angle for each point. 3) Calculate the new angle after step advancement. 4) Calculate the R–X coordinates.



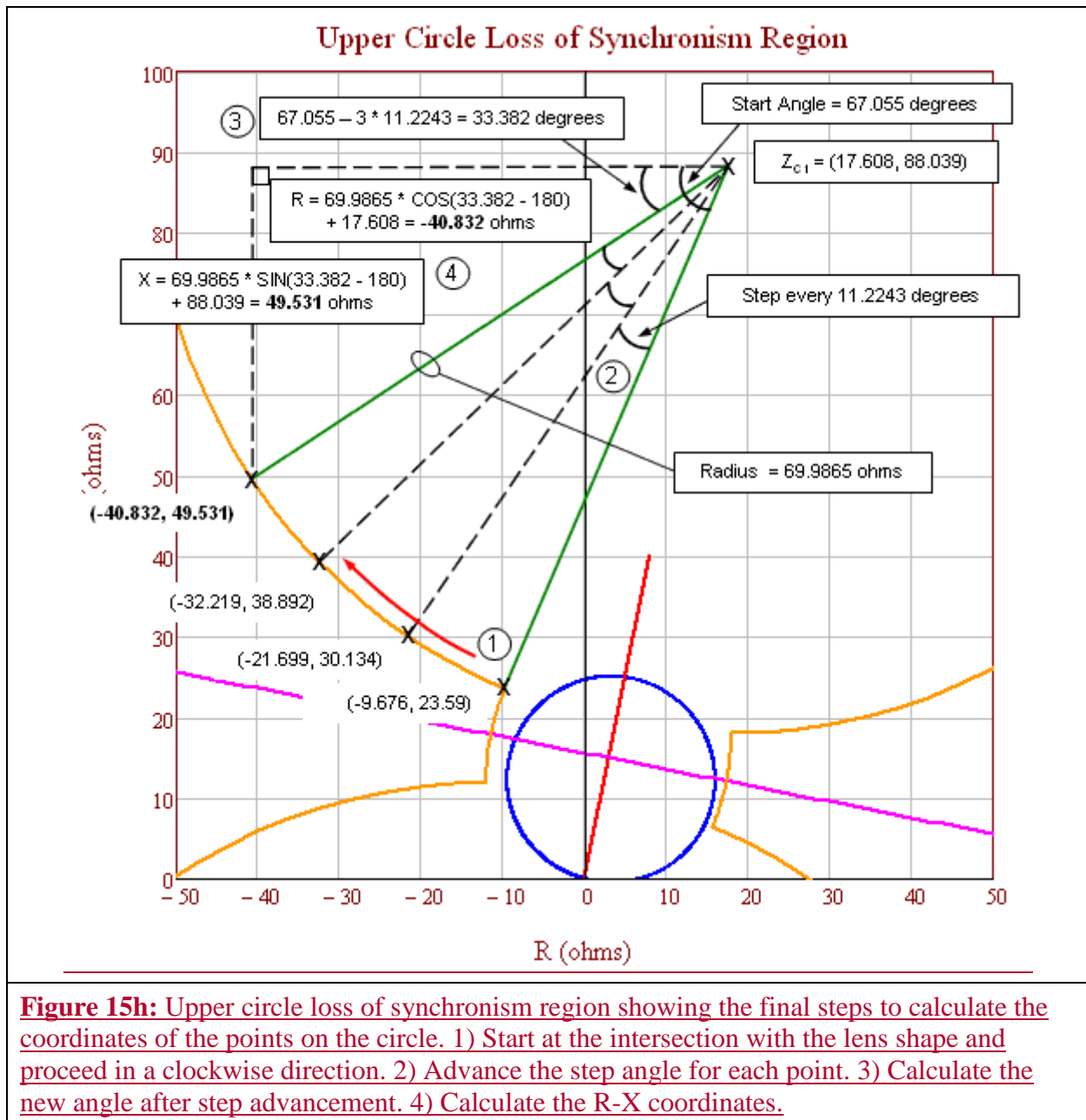


**Figure 15f:** Upper circle loss of synchronism region showing the first steps to calculate the coordinates of the points on the circle. 1) Identify the upper circle points that intersect the lens shape where the sending-end to receiving-end voltage ratio is 1.43 (see lens shape calculations in Tables 2-7). 2) Calculate the distance between the two upper circle points identified in Step 1. 3) Calculate the angle of arc that connects the two upper circle points identified in Step 1.



**Figure 15g:** Upper circle loss of synchronism region showing the steps to calculate the start angle, end angle, and the angle step size for the desired number of calculated points. 1) Calculate the system angle. 2) Calculate the start angle. 3) Calculate the end angle. 4) Calculate the angle step size for the desired number of points.





Lower Loss of Synchronism Circle Coordinates			Upper Loss of Synchronism Circle Coordinates		
Angle (degrees)	R	+ jX	Angle (degrees)	R	+ jX
67.055	15.676	6.41	67.055	-9.676	23.59
55.831	27.699	-0.134	55.831	-21.699	30.134
44.606	38.219	-8.892	44.606	-32.219	38.892
<b>33.382</b>	<b>46.832</b>	<b>-19.531</b>	<b>33.382</b>	<b>-40.832</b>	<b>49.531</b>
22.158	53.21	-31.643	22.158	-47.21	61.643
10.933	57.108	-44.765	10.933	-51.108	74.765
359.709	58.378	-58.395	359.709	-52.378	88.395
348.485	56.97	-72.011	348.485	-50.97	102.011
337.26	52.939	-85.092	337.26	-46.939	115.092
326.036	46.438	-97.139	326.036	-40.438	127.139
314.812	37.717	-107.69	314.812	-31.717	137.69
303.587	27.109	-116.341	303.587	-21.109	146.341
292.363	15.02	-122.762	292.363	-9.02	152.762
281.139	1.913	-126.707	281.139	4.087	156.707
269.914	-11.712	-128.026	269.914	17.712	158.026
258.69	-25.333	-126.667	258.69	31.333	156.667
247.466	-38.429	-122.682	247.466	44.429	152.682
236.241	-50.499	-116.225	236.241	56.499	146.225
225.017	-61.081	-107.542	225.017	67.081	137.542
213.793	-69.771	-96.965	213.793	75.771	126.965
202.568	-76.235	-84.899	202.568	82.235	114.899
191.344	-80.227	-71.806	191.344	86.227	101.806
180.12	-81.594	-58.185	180.12	87.594	88.185
168.895	-80.284	-44.56	168.895	86.284	74.56
157.671	-76.347	-31.45	157.671	82.347	61.45
146.447	-69.933	-19.357	146.447	75.933	49.357
135.222	-61.288	-8.744	135.222	67.288	38.744
123.998	-50.742	-0.016	123.998	56.742	30.016
112.774	-38.699	6.491	112.774	44.699	23.509
101.549	-25.62	10.53	101.549	31.62	19.47
90.325	-12.005	11.946	90.325	18.005	18.054

**Figure 15i:** Full tables of calculated lower and upper loss of synchronism circle coordinates. The highlighted row is the detailed calculated points in Figures 15d and 15h.

**Application Specific to Criteria B**

The PRC-026-1 – Attachment B, Criteria B evaluates overcurrent elements used for tripping. The same criteria as PRC-026-1 – Attachment B, Criteria A is used except for an additional criteria (No. 4) that calculates a current magnitude based upon generator terminal voltages of 1.05 per unit. The formula used to calculate the current is as follows:

**Table 14. Example Calculation (Overcurrent)**

This example is for a 230 kV line terminal with a directional instantaneous phase overcurrent element set to 50 amps secondary times a CT ratio of 160:1 that equals ~~80008,000~~ 8,000 amps ~~on the,~~ primary. The following calculation is where  $V_S$  equals the base line-to-ground sending-end generator source voltage times 1.05 at an angle of 120 degrees,  $V_R$  equals the base line-to-ground receiving-end generator terminal voltage times 1.05 at an angle of 0 degrees, and  $Z_{sys}$  equals the sum of the sending-end, line, and receiving-end source impedances in ohms.

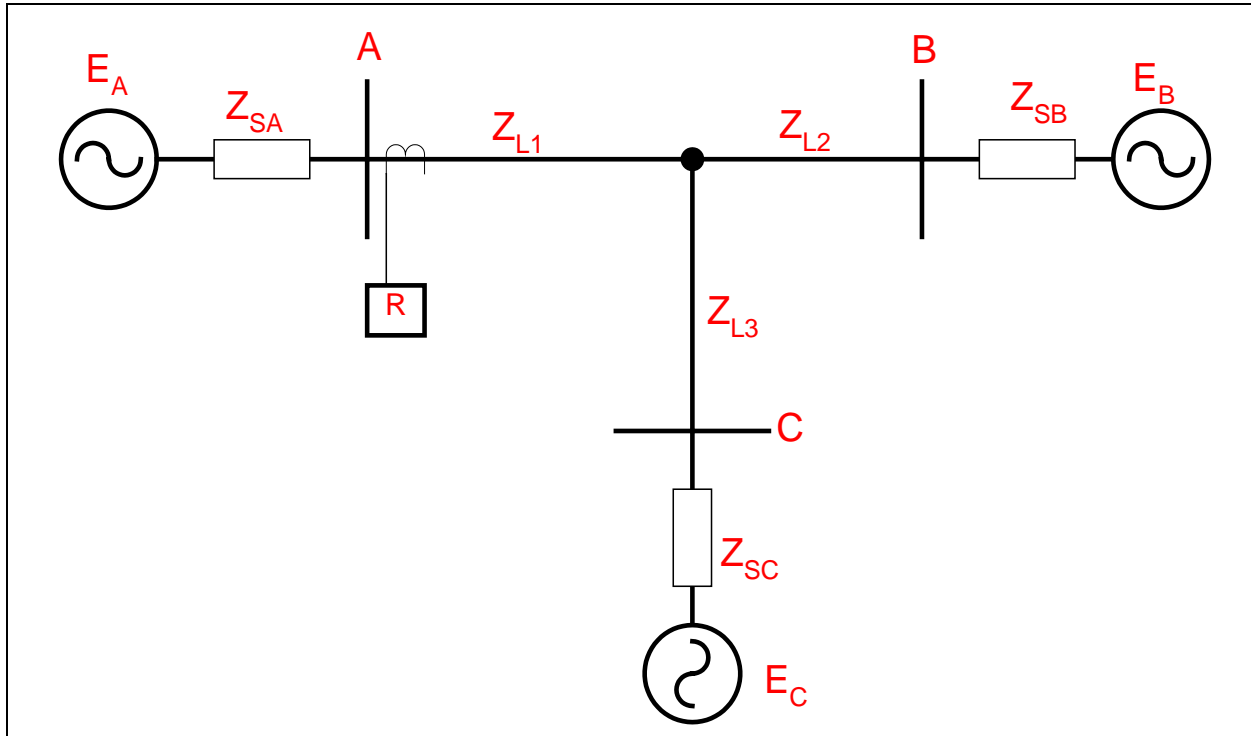
Here, the phase instantaneous setting of 8,000 amps is greater than the calculated system current of 5,716 amps; therefore, it meets PRC-026-1 – Attachment B, Criteria B.

Eq. (102)	$V_S = \frac{V_{LL} \angle 120^\circ}{\sqrt{3}} \times 1.05$		
	$V_S = \frac{230,000 \angle 120^\circ V}{\sqrt{3}} \times 1.05$		
	$V_S = 139,430 \angle 120^\circ V$		
Receiving-end generator terminal voltage.			
Eq. (103)	$V_R = \frac{V_{LL} \angle 0^\circ}{\sqrt{3}} \times 1.05$		
	$V_R = \frac{230,000 \angle 0^\circ V}{\sqrt{3}} \times 1.05$		
	$V_R = 139,430 \angle 0^\circ V$		
The total impedance of the system ( $Z_{sys}$ ) equals the sum of the sending-end source impedance ( $Z_S$ ), the impedance of the line ( $Z_L$ ), and receiving-end impedance ( $Z_R$ ) in ohms.			
Given:	$Z_S = 3 + j26 \Omega$	$Z_L = 1.3 + j8.7 \Omega$	$Z_R = 0.3 + j7.3 \Omega$
Eq. (104)	$Z_{sys} = Z_S + Z_L + Z_R$		
	$Z_{sys} = (3 + j26) \Omega + (1.3 + j8.7) \Omega + (0.3 + j7.3) \Omega$		
	$Z_{sys} = 4.6 + j42 \Omega$		
Total system current from sending-end source.			
Eq. (105)	$I_{sys} = \frac{(V_S - V_R)}{Z_{sys}}$		
	$I_{sys} = \frac{(139,430 \angle 120^\circ V - 139,430 \angle 0^\circ V)}{(4.6 + j42) \Omega}$		
	$I_{sys} = 5,715.82 \angle 66.25^\circ A$		

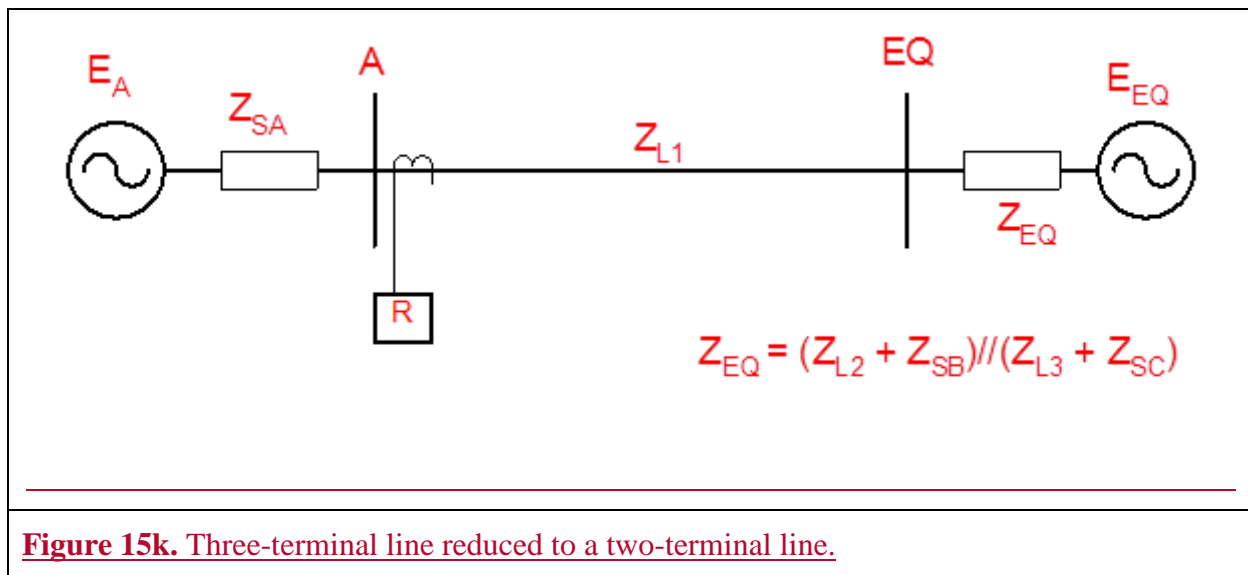
**Application Specific to Three-Terminal Lines**

If a three-terminal line is identified as an Element that is susceptible to a power swing based on Requirement R1, the load-responsive protective relays at each end of the three-terminal line must be evaluated.

As shown in Figure 15j, the source impedances at each end of the line can be obtained from the similar short circuit calculation as for the two-terminal line.



This example is for a 230 kV line terminal with a directional instantaneous phase overcurrent element set to 50 amps secondary times a CT ratio of 160:1 that equals 8,000 amps primary. Here, the phase instantaneous setting of 8,000 amps is greater than the calculated system current of 5,716 amps, therefore it is compliant with PRC-026-1 Attachment B, Criteria B. **Figure 15j.** Three-terminal line. To evaluate the load-responsive protective relays on the three-terminal line at Terminal A, the circuit in Figure 15j is first reduced to the equivalent circuit shown in Figure 15k. The evaluation process for the load-responsive protective relays on the line at Terminal A will now be the same as that of the two-terminal line.



**Figure 15k.** Three-terminal line reduced to a two-terminal line.

### Application to Generation Elements

As with ~~Transmission~~transmission BES Elements, the determination of the apparent impedance seen at an Element located at, or near, a generation Facility is complex for power swings due to various interdependent quantities. These variances in quantities are caused by changes in machine internal voltage, speed governor action, voltage regulator action, the reaction of other local generators, and the reaction of other interconnected transmission BES Elements as the event progresses through the time domain. Though transient stability simulations may be used to determine the apparent impedance for verifying load-responsive relay settings,<sup>16,17</sup> Requirement R4R2, PRC-026-1 – Attachment B, Criteria A and B provides a simplified method for evaluating the load-responsive protective relay’s susceptibility to tripping in response to a stable power swing without requiring stability simulations.

In general, the electrical center will be in the transmission system for cases where the generator is connected through a weak transmission system (high external impedance). Other cases where the generator is connected through a strong ~~transmission~~Transmission system, the electrical center could be inside the unit connected zone.<sup>18</sup> In either case, load-responsive protective relays connected at the generator terminals or at the high-voltage side of the generator step-up (GSU) transformer may be challenged by power swings as determined by the Planning Coordinator in Requirement R1 or becoming aware of a generator, transformer, or transmission line BES Element

<sup>16</sup> Donald Reimert, *Protective Relaying for Power Generation Systems*, Boca Raton, FL, CRC Press, 2006.

<sup>17</sup> Prabha ~~Kundur~~Kundur, *Power System Stability and Control*, EPRI, McGraw Hill, Inc., 1994.

<sup>18</sup> Ibid, ~~Kundur~~Kundur.

## PRC-026-1 – Application Guidelines

---

~~that tripped<sup>19</sup> in response to stable or unstable power swing event documented by an actual Disturbance due to the operation of its protective relay(s) in Requirement R2 and R3.~~

Load-responsive protective relays such as time over-current, voltage controlled time-overcurrent or voltage-restrained time-overcurrent relays are excluded from this standard ~~since~~<sup>if</sup> they are set based on equipment permissible overload capability. Their operating time is much greater than 15 cycles for the current levels observed during a power swing.

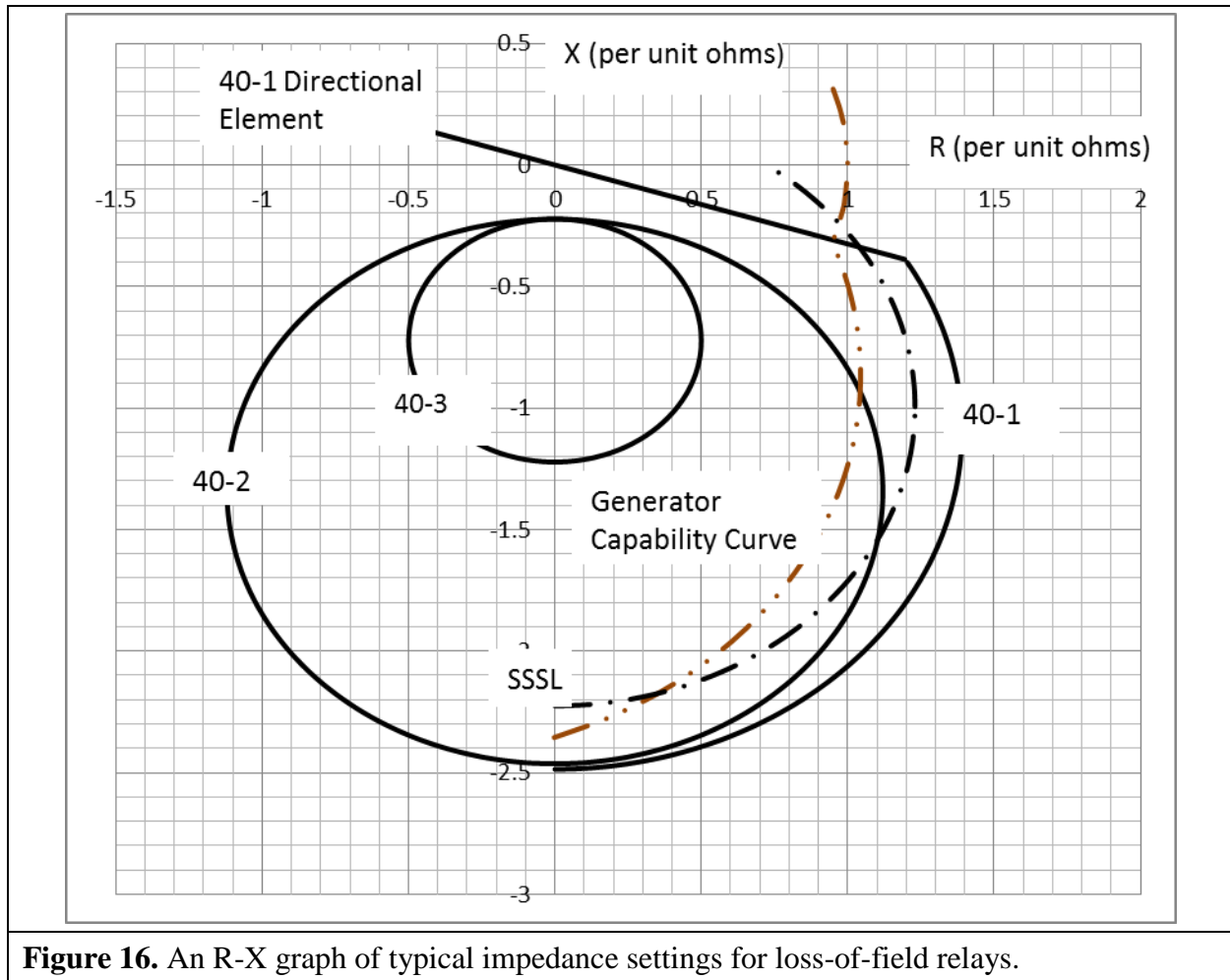
Instantaneous overcurrent and definite-time overcurrent relays with a time delay of less than 15 cycles are ~~included~~<sup>applicable</sup> and are required to be evaluated for identified Elements.

The generator loss-of-field protective function is provided by impedance relay(s) connected at the generator terminals. The settings are applied to protect the generator from a partial or complete loss of excitation under all generator loading conditions and, at the same time, be immune to tripping on stable power swings. It is more likely that the relay would operate during a power swing when the automatic voltage regulator (AVR) is in manual mode rather than when in automatic mode.<sup>20</sup> Figure 16 illustrates ~~in the R-X plot,~~ the loss-of-field ~~relays~~<sup>relay in the R-X plot, which</sup> typically ~~include~~<sup>includes</sup> up to three zones of protection.

---

<sup>19</sup> See Guidelines and Technical Basis section, “Becoming Aware of an Element That Tripped in Response to a Power Swing.”

<sup>20</sup> John Burdy, *Loss-of-excitation Protection for Synchronous Generators GER-3183*, General Electric Company.



**Figure 16.** An R-X graph of typical impedance settings for loss-of-field relays.

Loss-of-field characteristic 40-1 has a wider impedance characteristic (positive offset) than characteristic 40-2 or characteristic 40-3 and provides additional generator protection for a partial loss of field or a loss of field under low load (less than 10% of rated). The tripping logic of this protection scheme is established by a directional contact, a voltage setpoint, and a time delay. The voltage and time delay add security to the relay operation for stable power swings. Characteristic 40-3 is less sensitive to power swings than characteristic 40-2 and is set outside the generator capability curve in the leading direction. Regardless of the relay impedance setting, PRC-019<sup>21</sup> requires that the “in-service limiters operate before Protection Systems to avoid unnecessary trip” and “in-service Protection System devices are set to isolate or de-energize equipment in order to limit the extent of damage when operating conditions exceed equipment capabilities or stability limits.” Time delays for tripping associated with loss-of-field relays<sup>22,23</sup> have a range from 15 cycles for characteristic 40-2 to 60 cycles for characteristic 40-1 to minimize tripping during stable

<sup>21</sup> [Coordination of Generating Unit or Plant Capabilities, Voltage Regulating Controls, and Protection](#)

<sup>22</sup> Ibid, Burdy.

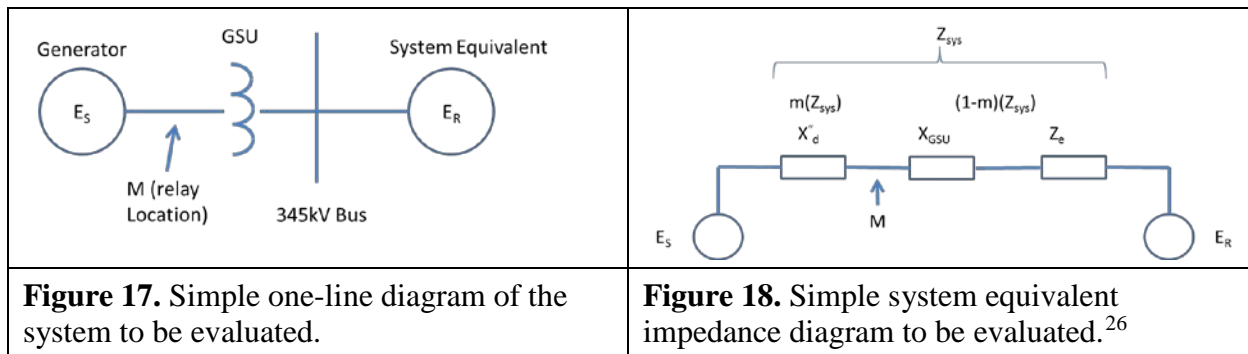
<sup>23</sup> *Applied Protective Relaying*, Westinghouse Electric Corporation, 1979.

## PRC-026-1 – Application Guidelines

power swings. In the standard, 15 cycles establishes a threshold for applicability; however, it is the responsibility of the Generator Owner to establish settings that provide security against stable power swings and, at the same time, dependable protection for the generator.

The simple two-machine system circuit (method also used in [the Application to Transmission Element Elements](#) section) is used to analyze the effect of a power swing at a generator facility for load-responsive relays ~~pursuant to Requirement R4.~~ In this section, the calculation method is used for calculating the impedance seen by the relay connected at a point in the circuit.<sup>24</sup> The electrical quantities used to determine the apparent impedance plot using this method are generator saturated transient reactance ( $X'_d$ ), GSU transformer impedance ( $X_{GSU}$ ), transmission line impedance ( $Z_L$ ), and the system equivalent ( $Z_e$ ) at the point of interconnection. All impedance values are known to the Generator Owner except for the system equivalent. The system equivalent is ~~available~~ obtainable from the Transmission Owner. The sending-end and receiving-end source voltages are varied from 0.70 to 1.0 per unit to form ~~a portion of a the lens characteristic instead of varying the voltages from 0 to 1.0 per unit which would form a full lens characteristic shape of the unstable power swing region.~~ The voltage range of 0.7 ~~to~~ 1.0 results in a ratio range from 0.7 to 1.43. This ratio range is used ~~in determining the portion to form the lower and upper loss-of-synchronism circle shapes of the lens-unstable power swing region.~~ A system separation angle of 120 degrees is ~~also used in~~ used in accordance with PRC-026-1 – Attachment B criteria for each load-responsive protective relay evaluation.

~~Below Table 15 below~~ is an example calculation of the apparent impedance locus method based on Figures ~~1817~~ and ~~1918~~.<sup>25</sup> In this example, the generator is connected to the 345 kV transmission system through the GSU transformer and has the ~~listed ratings listed.~~ Note that the load-responsive protective ~~relay responsibilities below are divided between~~ relays in this example may ~~have ownership with~~ the Generator Owner ~~and/or the~~ Transmission Owner.



<sup>24</sup> Edward Wilson Kimbark, *Power System Stability, Volume II: Power Circuit Breakers and Protective Relays*, Published by John Wiley and Sons, 1950.

<sup>25</sup> Ibid, Kimbark.

<sup>26</sup> Ibid, Kimbark.



<b>Table 15. Example Data (Generator)</b>	
<b>Input Descriptions</b>	<b>Input Values</b>
Synchronous Generator nameplate (MVA)	940 MVA
Sub-transient reactance (940MVA base—per unit)	$X''_d = X'_d = 0.3845$ (per unit)
Generator rated voltage (Line-to-Line)	20 kV
Generator step-up (GSU) transformer rating	880 MVA
GSU transformer reactance (880 MVA base)	$X_{GSU} = 16.05\%$
System Equivalent (100 MVA base)	$Z_e = 0.00723 \angle 86^\circ$ ohms
<b>Generator Owner Load-Responsive Protective Relays</b>	
40-1	Positive Offset Impedance
	Offset = 0.294 per unit ohms
	Diameter = 0.294 per unit ohms
40-2	Negative Offset Impedance
	Offset = 0.22 per unit ohms
	Diameter = 2.24 per unit ohms
40-3	Negative Offset Impedance
	Offset = 0.22 per unit ohms
	Diameter = 1.00 per unit ohms
21-1	Diameter = 0.643 per unit ohms
	MTA = 85°
50	I (pickup) = 5.0 per unit
<b>Transmission Owned Load-Responsive Protective Relays</b>	
21-2	Diameter = 0.55 per unit ohms
	MTA = 85°

Calculations shown for a 120 degree angle and  $E_S/E_R = 1$ . The equation for calculating  $Z_R$  is:<sup>27</sup>

$$\text{Eq. (106)} \quad Z_R = \left( \frac{(1 - m)(E_S \angle \delta) + (m)(E_R)}{E_S \angle \delta - E_R} \right) \times Z_{sys}$$

<sup>27</sup> Ibid, Kimbark.

## PRC-026-1 – Application Guidelines

Where  $m$  is the relay location as a function of the total impedance (real number less than 1)

$E_S$  and  $E_R$  is the sending-end and receiving-end voltages

$Z_{sys}$  is the total system impedance

$Z_R$  is the complex impedance at the relay location and plotted on an R-X diagram

All of the above are constants (940 MVA base) while the angle  $\delta$  is varied. Table 16 below contains calculations for a generator using the data listed in Table 15.

Table 16. Example Calculations (Generator)			
Given:	$X''_a = X'_d = j0.3845 \Omega$	$X_{GSU} = j0.171 \Omega$	$Z_e = 0.06796 \Omega$
Eq. (107)	$Z_{sys} = X''_a + X_{GSU} + X'_d + Z_e$		
	$Z_{sys} = j0.3845 \Omega + j0.171 \Omega + 0.06796 \Omega$		
	$Z_{sys} = 0.6239 \angle 90^\circ \Omega$		
Eq. (108)	$m = \frac{X''_a X'_d}{Z_{sys} Z_{sys}} = \frac{0.3845}{0.6239} = 0.61633$		
Eq. (109)	$Z_R = \left( \frac{(1-m)(E_S \angle \delta) + (m)(E_R)}{E_S \angle \delta - E_R} \right) \times Z_{sys}$		
	$Z_R = \left( \frac{(1-0.61633) \times (1 \angle 120^\circ) + (0.61633)(1 \angle 0^\circ)}{1 \angle 120^\circ - 1 \angle 0^\circ} \right) \times (0.6234 \angle 90^\circ) \Omega$		
	$Z_R = \left( \frac{0.4244 + j0.3323}{-1.5 + j0.866} \right) \times (0.6234 \angle 90^\circ) \Omega$		
	$Z_R = (0.3112 \angle -111.94^\circ) \times (0.6234 \angle 90^\circ) \Omega$		
	$Z_R = 0.194 \angle -21.94^\circ \Omega$		
	$Z_R = -0.18 - j0.073 \Omega$		

Table 17 lists the swing impedance values at other angles and at  $E_S/E_R = 1, 1.43,$  and  $0.7$ . The impedance values are plotted on an R-X graph with the center being at the generator terminals for use in evaluating impedance relay settings.

**Table 17:** Sample calculations for a swing impedance chart for varying voltages at the sending ~~end~~ and receiving-end.

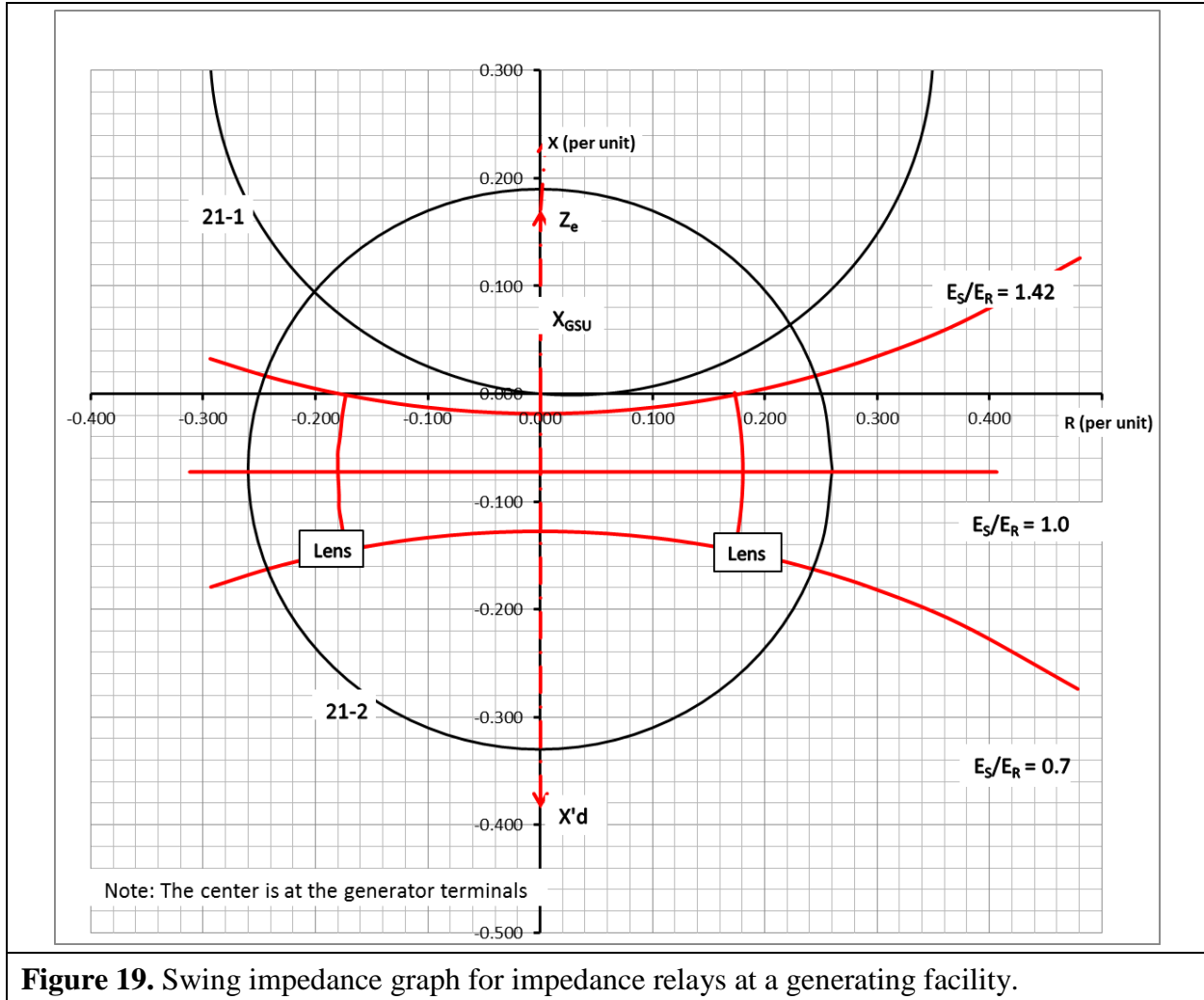
Angle ( $\delta$ ) (Degrees)	$E_S/E_R=1$		$E_S/E_R=1.43$		$E_S/E_R=0.7$	
	$Z_R$		$Z_R$		$Z_R$	
	Magnitude (PU Ohms)	Angle (Degrees)	Magnitude (PU Ohms)	Angle (Degrees)	Magnitude (PU Ohms)	Angle (Degrees)
90	0.320	-13.1	0.296	6.3	0.344	-31.5
120	0.194	-21.9	0.173	-0.4	0.227	-40.1
150	0.111	-41.0	0.082	-10.3	0.154	-58.4
210	0.111	-25.9	0.082	190.3	0.154	238.4
240	<del>0.111</del> 0.194	<del>221.0</del> 201.9	0.173	180.4	0.225	220.1
270	0.320	193.1	0.296	173.7	0.344	211.5

**Requirement ~~R4~~R2 Generator Examples**

***Distance Relay Application***

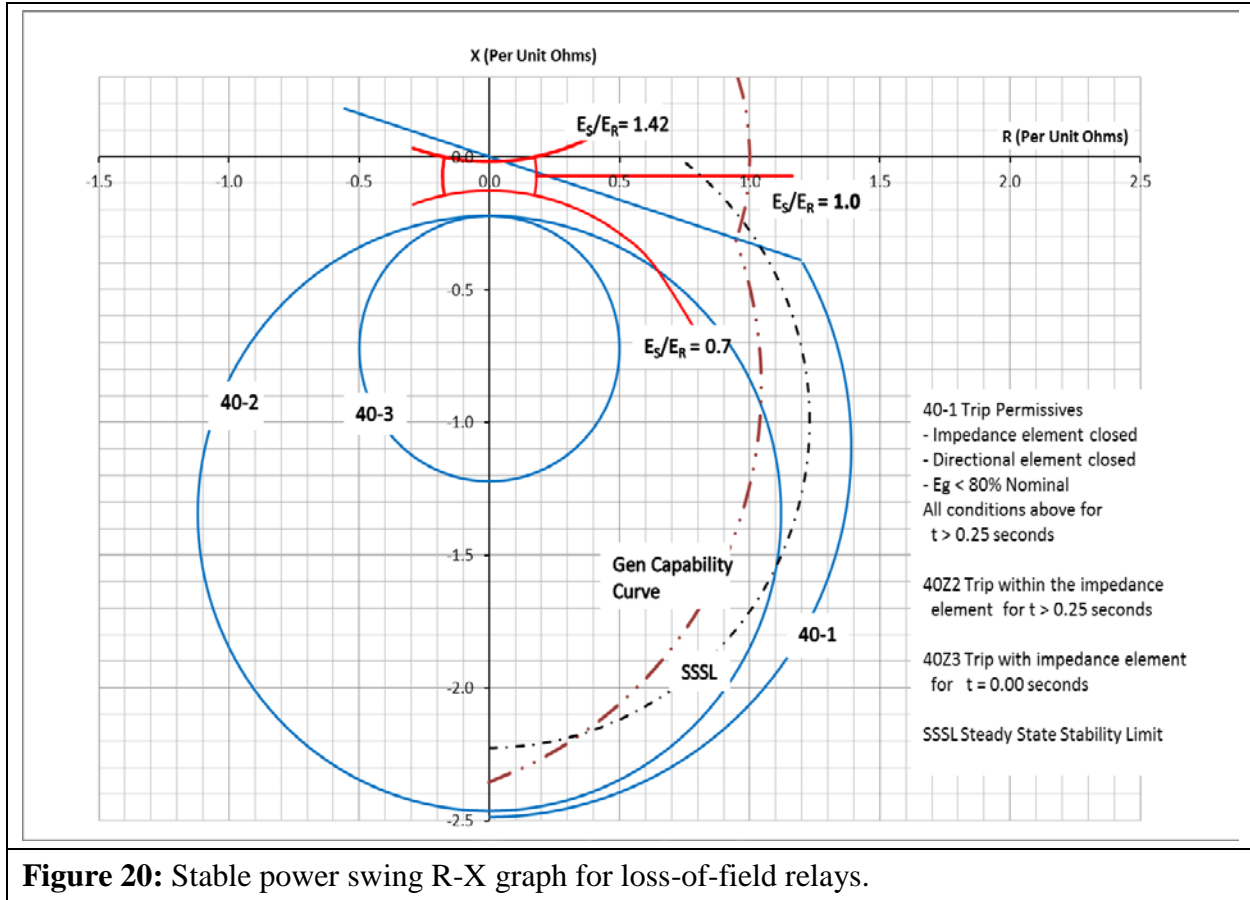
Based on PRC-026-1 – Attachment B, Criteria A, the distance relay (21-1) (*i.e.*, owned by the ~~generation entity~~ **Generation Owner**) characteristic is in the region where a stable power swing would not occur as shown in Figure 19. There is no further obligation to the owner in this standard for this load-responsive protective relay.

The distance relay (21-2) (*i.e.*, owned by the ~~transmission entity~~ **Transmission Owner**) is connected at the high-voltage side of the GSU transformer and its impedance characteristic is in the region where a stable power swing could occur causing the relay to operate. In this example, if the intentional time delay of this relay is less than 15 cycles, the **PRC-026 – Attachment B, Criteria B cannot be met, thus the** Transmission Owner is required to create a CAP (Requirement ~~R5~~ **to meet PRC 026 – Attachment B, Criteria B-R3**). Some of the options include, but are not limited to, changing the relay setting (*i.e.*, impedance reach, angle, time delay), modify the scheme (*i.e.*, add ~~power swing blocking~~ **PSB**), or replace the Protection System. Note that the relay may be excluded from this standard if it has an intentional time delay equal to or greater than 15 cycles.



**Loss-of-Field Relay Application**

In Figure 20, the R-X diagram shows the loss-of-field relay (40-1 and 40-2) characteristics are in the region where a stable power swing can cause a relay operation. Protective relay 40-1 would be excluded if it has an intentional time delay equal to or greater than 15 cycles. Similarly, 40-2 would be excluded if its intentional time delay is equal to or greater than 15 cycles. For example, if 40-1 has a time delay of 1 second and 40-2 has a time delay of 0.25 seconds, they are excluded and there is no further obligation ~~to~~ on the ~~owner~~ Generator Owner in this standard for these relays. The loss-of-field relay characteristic 40-3 is outside the region where a stable power swing can cause a relay operation. In this case, the owner may select high speed tripping on operation of the 40-3 impedance element.



**Instantaneous Overcurrent Relay**

In similar fashion to the transmission line overcurrent example calculation in Table 14, the instantaneous overcurrent relay minimum setting is established by PRC-026-1 – Attachment B, Criteria B. The solution is found by:

$$\text{Eq. (110)} \quad I_{sys} = \frac{E_S - E_R}{Z_{sys}}$$

As stated in the relay settings in Table 15, the relay is installed on the high-voltage side of the GSU transformer with a pickup of 5.0 per unit ~~current~~amps. The maximum allowable current is calculated below.

$$I_{sys} = \frac{(1.05 \angle 120^\circ - 1.05 \angle 0^\circ)}{0.6234 \angle 90^\circ} A$$

$$I_{sys} = \frac{1.775 \angle 150^\circ V}{0.6234 \angle 90^\circ \Omega} A$$

$$I_{sys} = 2.84 \angle 60^\circ A$$

## **PRC-026-1 – Application Guidelines**

---

The phase instantaneous setting of 5.0 per unit amps is greater than the calculated system current of 2.84 per unit amps; therefore, it ~~is compliant with~~ meets the PRC-026-1 – Attachment B, Criteria B.

### **Out-of-Step Tripping for Generation Facilities**

Out-of-step protection for the generator generally falls into three different schemes. The first scheme is a distance relay connected at the high-voltage side of the GSU transformer with the directional element looking toward the generator. Because this relay setting may be the same setting used for generator backup protection (see Requirement R2 Generator Examples, Distance Relay Application), it is susceptible to stable power swings and would require modification. Because this scheme is susceptible to stable power swings and any modification to the mho circle will jeopardize the overall protection of the out-of-step protection of the generator, available technical literature does not recommend using this scheme specifically for generator out-of-step protection. The second and third out-of-step Protection System schemes are commonly referred to as single and double blinder schemes. These schemes are installed or enabled for out-of-step protection using a combination of blinders, a mho element, and timers. The combination of these protective relay functions provides out-of-step protection and discrimination logic for stable and unstable power swings. Single blinder schemes use logic that discriminate between stable and unstable power swings by issuing a trip command after the first slip cycle. Double blinder schemes are more complex than the single blinder scheme and, depending on the settings of the inner blinder, a trip for a stable power swing may occur. While the logic discriminates between stable and unstable power swings in either scheme, it is important that the trip initiating blinders be set at an angle greater than the stability limit of 120 degrees to remove the possibility of a trip for a stable power swing. Below is a discussion of the double blinder scheme.

### **Double Blinder Scheme**

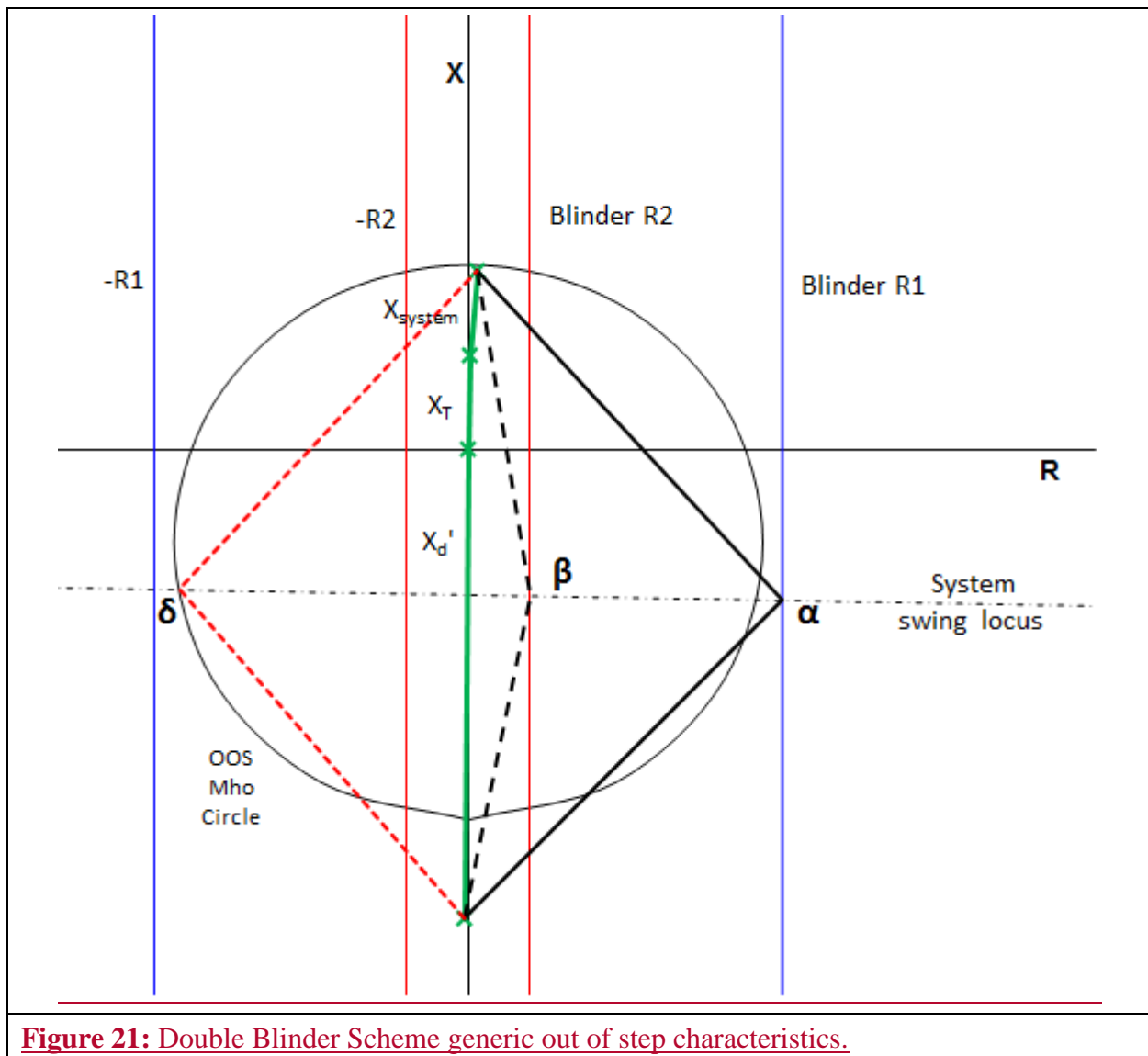
The double blinder scheme is a method for measuring the rate of change of positive sequence impedance for out-of-step swing detection. The scheme compares a timer setting to the actual elapsed time required by the impedance locus to pass between two impedance characteristics. In this case, the two impedance characteristics are simple blinders, each set to a specific resistive reach on the R-X plane. Typically, the two blinders on the left half plane are the mirror images of those on the right half plane. The scheme typically includes a mho characteristic which acts as a starting element, but is not a tripping element.

The scheme detects the blinder crossings and time delays as represented on the R-X plane as shown in Figure 21. The system impedance is composed of the generator transient ( $X_d'$ ), GSU transformer ( $X_T$ ), and transmission system ( $X_{system}$ ), impedances.

The scheme logic is initiated when the swing locus crosses the outer Blinder R1 (Figure 21), on the right at separation angle  $\alpha$ . The scheme only commits to take action when a swing crosses the inner blinder. At this point the scheme logic seals in the out-of-step trip logic at separation angle  $\beta$ . Tripping actually asserts as the impedance locus leaves the scheme characteristic at separation angle  $\delta$ .

## PRC-026-1 – Application Guidelines

The power swing may leave both inner and outer blinders in either direction and tripping will assert. Therefore, the inner blinder must be set such that the separation angle  $\beta$  is large enough that the system cannot recover. This angle should be set at 120 degrees or more. Setting the angle greater than 120 degrees satisfies the PRC-026-1 – Attachment B Criteria A (No. 1, 1<sup>st</sup> bullet) since the tripping function is asserted by the blinder element. Transient stability studies are usually required to determine an appropriate inner blinder setting. Such studies may indicate that a smaller stability limit angle is acceptable under PRC-026-1 – Attachment B Criteria A (No. 1, 2<sup>nd</sup> bullet). In this respect, the double blinder scheme is similar to the double lens and triple lens schemes, and many transmission application out-of-step schemes.

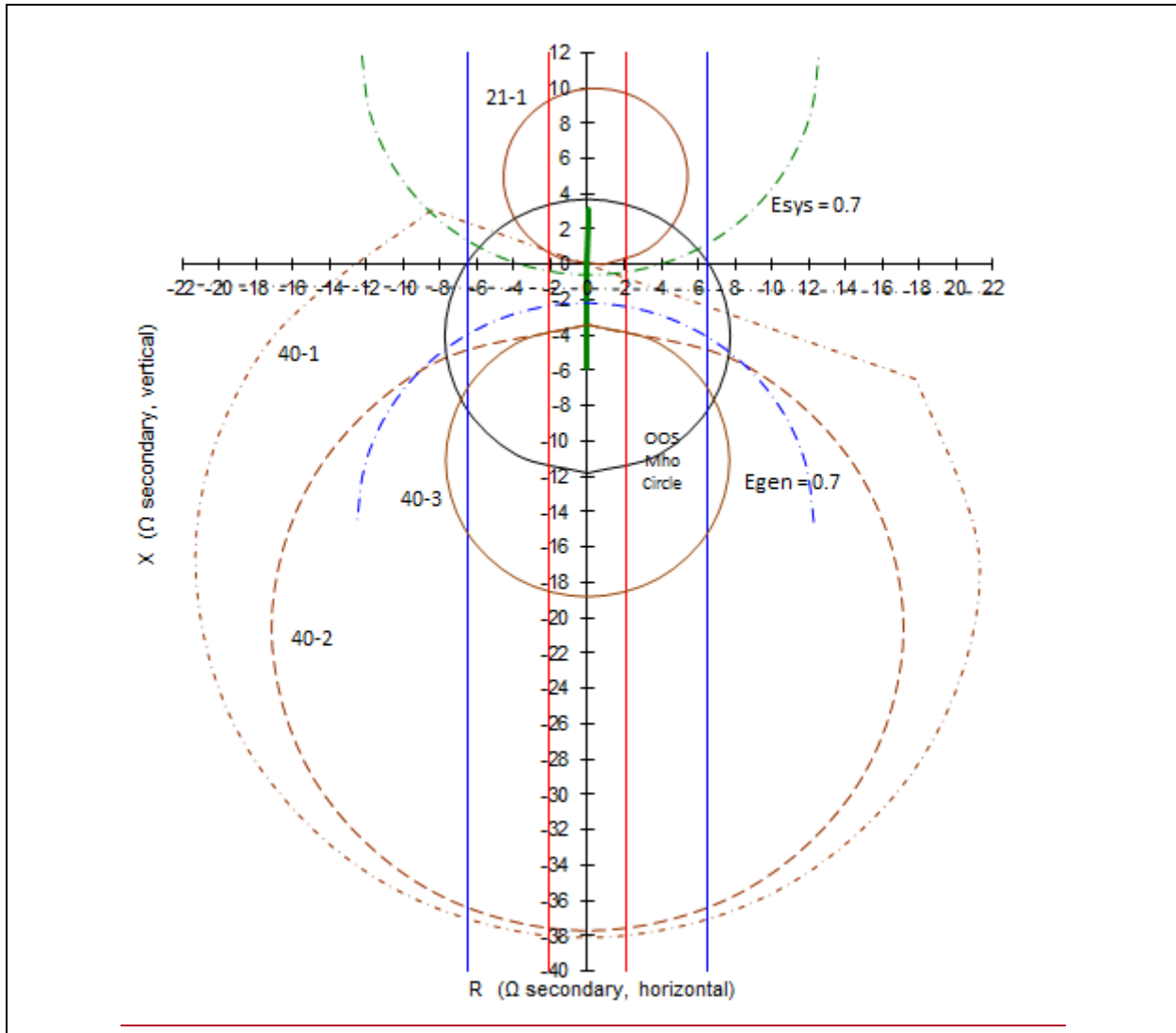


**Figure 21:** Double Blinder Scheme generic out of step characteristics.

Figure 22 illustrates a sample setting of the double blinder scheme for example 940 MVA generator. The only setting requirement for this relay scheme is the right inner blinder, which

## PRC-026-1 – Application Guidelines

must be set greater than the separation angle of 120 degrees (or a lesser angle based on a transient stability study) to ensure that the out-of-step protective function is expected to not trip in response to a stable power swing during non-Fault conditions. Other settings such as the  $mho$  characteristic, outer blinders, and timers are set according to transient stability studies and are not a part of this standard.



**Figure 22:** Double Blinder Out-of-Step Scheme with unit impedance data and load-responsive protective relay impedance characteristics for the example 940 MVA generator, scaled in relay secondary ohms.



### Requirement R3~~Requirement R5~~

~~This requirement ensures that all actions associated with any Corrective Action Plan (CAP) developed in the previous requirement are completed. The requirement also permits the entity to modify a CAP as necessary, while in the process of fulfilling the purpose of the standard.~~

To achieve the stated purpose of this standard, which is to ensure that relays are expected to not trip in response to stable power swings during non-Fault conditions, this Requirement ensures that the applicable entity is required to develop and completedevelops a Corrective Action Plan (CAP) that reduces the risk of relays tripping during in response to a stable power swing during non-Fault conditions that may occur on any applicable BES Element of the BES. Protection System owners are required, during the implementation of a CAP, to update it when any action or timetable changes until the CAP is completed. Accomplishing this objective is intended to reduce the risk of the relays unnecessarily tripping during stable power swings, thereby improving reliability and reducing risk to the BES.

### Requirement R4

To achieve the stated purpose of this standard, which is to ensure that load-responsive protective relays are expected to not trip in response to stable power swings during non-Fault conditions, the applicable entity is required to implement any CAP developed pursuant to Requirement R3 such that the Protection System will meet PRC-026-1 – Attachment B criteria or can be excluded under the PRC-026-1 – Attachment A criteria (e.g., modifying the Protection System so that relay functions are supervised by power swing blocking or using relay systems that are immune to power swings), while maintaining dependable fault detection and dependable out-of-step tripping (if out-of-step tripping is applied at the terminal of the BES Element). Protection System owners are required in the implementation of a CAP to update it when actions or timetable change, until all actions are complete. Accomplishing this objective is intended to reduce the occurrence of Protection System tripping during a stable power swing, thereby improving reliability and minimizing risk to the BES.

The following are examples of actions taken to complete CAPs for a relay that did not meet PRC-026-1 – Attachment B and could be exposed at risk of tripping in response to a stable power swing and a setting during non-Fault conditions. A Protection System change was determined to be acceptable (without diminishing the ability of the relay to protect for faults within its zone of protection).

**Example R5aR4a:** Actions: Settings were issued on 6/02/2015 to reduce the ~~zone~~Zone 2 reach of the impedance relay used in the ~~permissive overreaching transfer trip (POTT)~~directional comparison unblocking (DCUB) scheme from 30 ohms to 25 ohms so that the relay characteristic is completely contained within the lens characteristic identified by the criterion. The settings were applied to the relay on 6/25/2015. CAP was completed on 06/25/2015.

## PRC-026-1 – Application Guidelines

---

**Example R5bR4b:** Actions: Settings were issued on 6/02/2015 to enable out-of-step blocking on the existing microprocessor-based relay to prevent tripping in response to stable power swings. The setting changes were applied to the relay on 6/25/2015. CAP was completed on 06/25/2015.

The following is an example of actions taken to complete a CAP for a relay responding to a stable power swing that required the addition of an electromechanical power swing blocking relay.

**Example R5eR4c:** Actions: A project for the addition of an electromechanical power swing blocking relay to supervise the zoneZone 2 impedance relay was initiated on 6/5/2015 to prevent tripping in response to stable power swings. The relay installation was completed on 9/25/2015. CAP was completed on 9/25/2015.

The following is an example of actions taken to complete a CAP with a timetable that required updating for the replacement of the relay.

**Example R5dR4d:** Actions: A project for the replacement of the impedance relays at both terminals of line X with line current differential relays was initiated on 6/5/2015 to prevent tripping in response to stable power swings. The completion of the project was postponed due to line outage rescheduling from 11/15/2015 to 3/15/2016. Following the timetable change, the impedance relay replacement was completed on 3/18/2016. CAP was completed on 3/18/2016.

The CAP is complete when all the documented actions to resolveremedy the specific problem (i.e., unnecessary tripping during stable power swings) are completed.

### **Requirement R6**

~~To achieve the stated purpose of this standard, which is to ensure that load responsive protective relays are expected to not trip in response to stable power swings during non-Fault conditions, the applicable entity is required to fully implement any CAP developed pursuant to Requirement R5 that modifies the Protection System to meet PRC-026-1— Attachment B, Criteria A and B. Protection System owners are required in the implementation of a CAP to update it when actions or timetable change, until all actions are complete. Accomplishing this objective is intended to reduce the occurrence of Protection System tripping during a stable power swing, thereby improving reliability and minimizing risk to the BES.~~

## Implementation Plan

### Project 2010-13.3 – Relay Loadability: Stable Power Swings

#### Requested Approvals

PRC-026-1 – Relay Performance During Stable Power Swings

#### Requested Retirements

None.

#### Prerequisite Approvals

None.

#### General Considerations

There are a number of factors that influence the determination of an implementation period for the new proposed standard. The following factors may be specific to one or more of the applicable entities listed below.

1. The effort and resources for all applicable entities to develop or modify internal processes and/or procedures.
2. The effort and resources for the Planning Coordinator to begin identifying Element(s) according to the criteria in Requirement R1 based on existing information (e.g., the most recent Planning Assessment).
3. The notification of Elements in Requirement R1 is based on the Planning Coordinator's existing studies (i.e., annual Planning Assessments) and there will be minimal additional effort to identify Elements according to the criteria.
4. The need for the Generator Owner or Transmission Owner to plan for and secure resources (e.g., availability of consultants, if needed) to address the initial influx of Elements from the Planning Coordinator during the implementation period of Requirement R2.

#### Applicable Entities

Generator Owner

Planning Coordinator

Transmission Owner

## Effective Dates

### Requirement R1

First day of the first full calendar year that is 12 months after the date that the standard is approved by an applicable governmental authority or as otherwise provided for in a jurisdiction where approval by an applicable governmental authority is required for a standard to go into effect. Where approval by an applicable governmental authority is not required, the standard shall become effective on the first day of the first full calendar year that is 12 months after the date the standard is adopted by the NERC Board of Trustees or as otherwise provided for in that jurisdiction.

### Requirements R2, R3, and R4

First day of the first full calendar year that is 36 months after the date that the standard is approved by an applicable governmental authority or as otherwise provided for in a jurisdiction where approval by an applicable governmental authority is required for a standard to go into effect. Where approval by an applicable governmental authority is not required, the standard shall become effective on the first day of the first full calendar year that is 36 months after the date the standard is adopted by the NERC Board of Trustees or as otherwise provided for in that jurisdiction.

### Notifications Prior to the Effective Date of R2

During the implementation of the standard, notifications are likely to occur prior to Requirement R2 becoming effective. Where notification of Elements under Requirement R1 or becoming aware of an Element tripping due to a stable or unstable power swing prior to the Effective Date of Requirement R2, the 12 month time period to evaluate if an Element's load-responsive protective relays meet the criteria in PRC-026-1 – Attachment B in Requirement R2 will begin, as expected, from the Effective Date of Requirement R2. Thereafter, entities will follow the 12 month time period in accordance with Requirement R2. The intention of the additional time for R2 to become effective is to handle the initial influx of notifications and identifications.

### Justification

The implementation plan is based on the general considerations above and provides sufficient time for the Generator Owner, Planning Coordinator, and Transmission Owner to begin becoming compliant with the standard. The Effective date is constructed such that once the standard is adopted or approved it would become effective on the first day of the first whole calendar year that is 12 months for Requirement R1 and 36 months for Requirements R2, R3, and R4 after adoption or approval.

**Requirement R1** – The Planning Coordinator will have at least one full calendar year to prepare itself to identify any generator, transformer, and transmission line BES Elements that meet the criteria and notify the respective Generator Owner and Transmission Owner of identified Elements, if any, within the allotted timeframe.

**Requirement R2** – The Generator Owner and Transmission Owner will have 36 calendar months to determine if its load-responsive protective relays for an identified Element pursuant to Requirement R1 meet the Attachment B criteria. Also, both entities are provided an implementation that will allow the entity to conduct initial evaluations of its load-responsive protective relays for an identified Element during the first 36 calendar months of approval.

**Requirement R3** – The implementation period for the development of a Corrective Action Plan (CAP) is set to be consistent with Requirement R2 to begin during the fourth calendar year of adoptions or approvals to address any load-responsive protective relays determined in Requirement R2 not to meet the Attachment B criteria.

**Requirement R4** – The implementation period for this Requirement is set to be consistent with Requirement R3, the development of a CAP.

# Implementation Plan

## Project 2010-13.3 – Relay Loadability: Stable Power Swings

### Requested Approvals

PRC-026-1 – Relay Performance During Stable Power Swings

### Requested Retirements

None.

### Prerequisite Approvals

None.

### General Considerations

There are a number of factors that influence the determination of an implementation period for the new proposed standard. The following factors may be specific to one or more of the applicable entities listed below.

1. The effort and resources for all applicable entities to develop or modify internal processes and/or procedures.
2. The effort and resources for the Planning Coordinator to ~~identify the~~begin identifying Element(s) according to the ~~criterion~~criteria in Requirement R1: based on existing information (e.g., the most recent Planning Assessment).
3. The notification of Elements in Requirement R1 is based on the Planning Coordinator's existing studies (i.e., annual Planning Assessments) and there will be minimal additional effort to identify Elements according to the criteria.
3. ~~The need for the Generator Owner or Transmission Owner to plan for and secure resources (e.g., availability of consultants, if needed) to evaluate each load responsive protective relay's response to a stable power swing for identified Elements.~~
4. ~~The~~address the initial influx of Elements from the Planning Coordinator during the implementation period of ~~time for a Generator Owner or Transmission Owner to develop a Corrective Action Plan to modify its Protection System.~~<sup>4</sup>Requirement R2.

<sup>4</sup> The period of time that may be required for a Generator Owner or Transmission Owner to take an Element outage, if necessary, to modify the Protection System is driven through the Corrective Action Plan (CAP) and is independent of the standard's implementation period. The CAP includes its own timetable which is at the discretion of the entity.

**Applicable Entities**

Generator Owner  
 Planning Coordinator  
 Transmission Owner

**Effective ~~Date~~ Dates****Requirement ~~Requirements R1-R3, R5, and R6~~****R1**

First day of the first full calendar year that is 12 months after the date that the standard is approved by an applicable governmental authority or as otherwise provided for in a jurisdiction where approval by an applicable governmental authority is required for a standard to go into effect. Where approval by an applicable governmental authority is not required, the standard shall become effective on the first day of the first full calendar year that is 12 months after the date the standard is adopted by the NERC Board of Trustees or as otherwise provided for in that jurisdiction.

**Requirement ~~Requirements R2, R3, and R4~~**

First day of the first full calendar year that is 36 months after the date that the standard is approved by an applicable governmental authority or as otherwise provided for in a jurisdiction where approval by an applicable governmental authority is required for a standard to go into effect. Where approval by an applicable governmental authority is not required, the standard shall become effective on the first day of the first full calendar year that is 36 months after the date the standard is adopted by the NERC Board of Trustees or as otherwise provided for in that jurisdiction.

**Notifications Prior to the Effective Date of ~~R4~~ R2**

During the implementation of the standard, notifications are likely to occur prior to Requirement ~~R4~~ R2 becoming effective. Where notification ~~under R1 or identification of Elements~~ under Requirement ~~R2~~ R1 or becoming aware of an Element tripping due to a stable or ~~R3 occurs~~ unstable power swing prior to the Effective Date of Requirement ~~R4~~ R2, the 12 month time period ~~to evaluate if an Element's load-responsive protective relays meet the criteria in PRC-026-1 – Attachment B~~ in Requirement ~~R4~~ R2 will begin, ~~as expected~~, from the Effective Date of Requirement ~~R4~~ R2. Thereafter, entities will follow the 12 month time period in ~~R4~~ accordance with Requirement R2. The intention of the additional time for ~~R4~~ R2 to become effective is to handle the initial influx of notifications and identifications.

**Justification**

The implementation plan is based on the general considerations above and provides sufficient time for the Generator Owner, Planning Coordinator, and Transmission Owner to begin becoming compliant with the standard. The Effective date is constructed such that once the standard is adopted or approved it would become effective ~~in on the first day of~~ the first whole calendar year ~~after approvals~~ that is 12 months for ~~Requirements R1-R3, R5, and R6~~, Requirement R1 and 36 months for ~~Requirement~~ Requirements R2, R3, and R4 ~~after adoption or approval~~.

**Requirement R1** – The Planning Coordinator will have at least one full calendar year to prepare itself to identify any generator, transformer, and transmission line BES Elements that meet the criteria and notify the respective Generator Owner and Transmission Owner of ~~any~~ identified Elements, if any, within the allotted timeframe.

~~**Requirement R2** – The Transmission Owner will have at least one year to prepare itself with identifying any Element that trips due to a stable or unstable power swing during an actual system Disturbance due to the operation of its load-responsive protective relays, or any Element that forms the boundary of an island during an actual system Disturbance due to the operation of its protective relays. This includes providing the applicable notifications to the Planning Coordinator within the allotted timeframe.~~

~~**Requirement R3** – The Generator Owner will have at least one year to prepare itself with identifying any Element that trips due to a stable or unstable power swing during an actual system Disturbance due to the operation of its load-responsive protective relays. This includes providing the applicable notifications to the Planning Coordinator within the allotted timeframe.~~

~~**Requirement R4** – The Generator Owner and Transmission Owner will have at least three years to develop internal processes and procedures for evaluating 36 calendar months to determine if~~ its load-responsive protective relays for an identified Element pursuant to ~~Requirements~~ Requirement R1, R2, and R3 meet the Attachment B criteria. Also, both entities are provided an implementation that will allow the entity to conduct initial evaluations of its load-responsive protective relays for an identified Element during the first 36 calendar months of approval.

~~**Requirement R5**~~ **R3** – The ~~Generator Owner and Transmission Owner will have at least one year to develop internal processes and procedures~~ implementation period for developing the development of a Corrective Action Plan (CAP) for addressing is set to be consistent with Requirement R2 to begin during the fourth calendar year of adoptions or approvals to address any Protection System for an identified Element that requires modification load-responsive protective relays determined in Requirement R2 not to meet ~~PRC 206-1~~ the Attachment B, Criteria A and B criteria.

~~**Requirement R6**~~ **R4** – The ~~Generator Owner and Transmission Owner will have at least one year to develop internal processes and procedures~~ implementation period for implementing any CAPs developed in this Requirement R5 is set to be consistent with Requirement R3, the development of a CAP.



# Unofficial Comment Form

## Project 2010-13.3 – Relay Loadability: Stable Power Swings

Please **DO NOT** use this form for submitting comments. Please use the electronic form to submit comments on the Standard. The electronic comment form must be completed by **8 p.m. Eastern, Monday, November 24, 2014.**

If you have questions please contact Scott Barfield-McGinnis, Standards Developer at [scott.barfield@nerc.net](mailto:scott.barfield@nerc.net) or by telephone at 404-446-9689.

<http://www.nerc.com/pa/Stand/Pages/Project2010133Phase3of-RelayLoadabilityStablePowerSwings.aspx>

### Background Information

This posting is soliciting formal comment.

This is Phase 3 of a three-phased standard development that is focused on developing a new Reliability Standard, PRC-026-1 – Relay Performance During Stable Power Swings, to address protective relay operations due to stable power swings. The March 18, 2010, the Federal Energy Regulatory Commission (FERC) Order No. 733, approved Reliability Standard PRC-023-1 – Transmission Relay Loadability. In this Order, FERC directed NERC to address three areas of relay loadability that include modifications to the approved PRC-023-1, development of a new Reliability Standard to address generator protective relay loadability, and a new Reliability Standard to address the operation of protective relays due to stable power swings. This project's SAR addresses these directives with a three-phased approach to standard development.

Phase 1 focused on making the specific modifications to PRC-023-1 and was completed in the approved Reliability Standard PRC-023-2, which became mandatory on July 1, 2012. Phase 2 focused on developing a new Reliability Standard, PRC-025-1 – Generator Relay Loadability, to address generator protective relay loadability. PRC-025-1 became mandatory on October 1, 2014 along with PRC-023-2, which was modified to harmonize PRC-023-2 with PRC-025-1. This Phase 3 of the project focuses on developing a new Reliability Standard, PRC-026-1 – Relay Performance During Stable Power Swings, to address protective relay operations due to stable power swings. This Reliability Standard will establish requirements aimed at preventing protective relays from tripping unnecessarily due to stable power swings by requiring the Transmission Owners and Generator Owners to assess the security of protective relay systems that are susceptible to operation during stable and unstable power swings, and take actions to improve security for only stable power swings where such actions would not compromise dependable operation for faults and unstable power swings.

## Summary of Changes from Draft 2 to Draft 3

The following is a summary of the change made to the proposed PRC-026-1 NERC Reliability Standard.

### Applicability

Section 4.2, Facilities was revised from “The following Bulk Electric System Elements” to “The following Elements that are part of the Bulk Electric System (BES)” to clarify that the listed items are the items being addressed in the Requirements as the “Elements.”

### Requirement R1

The Elements from the Applicability 4.2 (i.e., generator, transformer, and transmission line BES Elements) was added for clarity. Also, the Requirement was modified to specifically require “notification” rather than “identify and provide notification.” Identification of Elements based on the criteria is implied and necessary as a part of the Requirement.

### Requirement R1, Criterion 1

The term “operating limit” was clarified to be “System Operating Limit (SOL)” to remove ambiguity between the operating and planning time frame. Also, “transmission switching station” was revised to be “Transmission station.” The word “switching” did not add any additional clarity and the capitalized term “Transmission” references the *Glossary of Terms Used in NERC Reliability Standards*.

### Requirement R1, Criterion 2

The phrase “constraints identified in system planning or operating studies” was modified to be “...a SOL identified by the Planning Coordinator’s methodology.” This allows the Standard to draw a connection between the FAC-010 standard applicable to the Planning Coordinator in the planning horizon.

### Requirement R1, Criterion 3

This criterion originally identified Elements that formed the boundary of an island which in many cases would include Elements that were selected as arbitrary separation points and are not intended to be included within the scope of the Standard. Therefore, Criterion 3 was rewritten to reflect it is the Element which tripped on angular stability thus forming the island. Also, the criterion was updated to reflect the most recent “design assessment” by the Planning Coordinator (i.e., PRC-006) and when the Planning Coordinator uses angular stability as a design criteria for identifying islands.

### Requirement R1, Criterion 4

The term “annual” was added to provide clarity.

### Requirement R1, Criterion 5

Criterion 5 was removed from Requirement R1 because Requirements R2 and R3 in Draft 2 were eliminated. Those Requirements directed the Transmission Owner and Generator Owner to notify the Planning Coordinator of Elements that actually tripped due to a stable or unstable power swing. Criterion

5 created a loopback to the Generator Owner and Transmission Owner to ensure that load-responsive protective relays on identified Elements were evaluated on a periodic basis. Actual tripping events are now included in Requirement R2 (previously Requirement R4) and do not require periodic review, unless the Element trips due to a stable or unstable power swing.

#### **Measure M1**

Measure M1 was updated to reflect changes to Requirement R1 and to clarify that the focus is on notification and not identification of Elements.

#### **Requirements R2 and R3**

These Requirements were removed due to structural changes in Requirement R4 (now Requirement R2). The evaluation Requirement (now R2) was restructured to have two conditions for performance; 1) upon notification of an Element pursuant to Requirement R1, and 2) an actual event due to a stable or unstable power swing.

#### **Requirement R4**

This Requirement became Requirement R2 due to the removal of Requirements R2 and R3. Most significantly, the Requirement was restructured to incorporate the removal of Requirements R2 and R3. It was determined that Elements that tripped due to a stable or unstable power swing (R2/R3) would be infrequent and more than likely a significantly large event which the Planning Coordinator would be aware of through an event analysis. The new structure of the Requirement causes an evaluation; however, it would not be necessary for the Planning Coordinator to be notified and then to continue notifying the Generator Owner and Transmission Owner. Elements that actually tripped due to stable or unstable power swings are not typical and requiring the Generator Owner and Transmission Owner to do a one-time analysis is sufficient to address the risk.

#### **Requirements R5 and R6**

These Requirements became Requirements R3 and R4 due to the removal of Requirements R2 and R3. Requirement R3 to develop the Corrective Action Plan (CAP) was inflexible as it only allowed the modification of a Protection System that did not meet the PRC-026-1 – Attachment B criteria. To correct this issue, Requirement R3 was modified to meet the purpose of the standard which is to ensure that load-responsive protective relays are expected to not trip in response to stable power swings during non-Fault conditions. First, the Requirement was revised to include two conditions. The first condition requires a CAP to be developed such that the Protection System will meet the PRC-026-1 – Attachment B criteria. For example, this may include a Protection System modification or a system configuration change which causes the Protection System to meet the criteria. Second, the CAP allows power swing block to be applied such that the Protection System may be excluded from the Standard.

Also, the development period of the CAP was extended from 90 calendar days to six calendar months due to the complexities that might be involved with determining appropriate remediation of a Protection System that did not meet PRC-026-1 – Attachment B criteria.

### **Compliance Section**

Section C1.1.2 was modified to conform evidence retention to the Reliability Assurance Initiative (RAI). Retention periods were set to 12 calendar months.

### **Violation Severity Levels**

The Violation Severity Levels (VSL) were modified to align them with the revisions made to the Requirements.

### **PRC-026-1 – Attachments A and B**

Attachment A received editorial changes and Attachment B, Criteria A was rewritten to clarify that a relay characteristic that is completely contained within the unstable power swing region meets the criteria. The unstable power swing region is formed by the union of three shapes in the impedance (R-X) plane.

### **Guidelines and Technical Basis**

This section was revised substantively in response to comments and due to the removal of Requirements R2 and R3. Revisions are too numerous to list here effectively. Please see the Guidelines and Technical Basis redline document for changes.

### **Implementation Plan**

The period for implementing the standard did not change substantively. Based on comments, the implementation time frame for Requirements R5 and R6 (now Requirements R3 and R4) were increased from 12 calendar months to 36 calendar months to align them with Requirement R4 (now Requirement R2).

*\*Please use the [electronic comment form](#) to submit your final comments to NERC.*

**You do not have to answer all questions. Enter All Comments in Simple Text Format.**

Please note that the official comment form **does not** retain formatting (even if it appears to transfer formatting when you copy from the unofficial Word version of the form into the official electronic comment form). If you enter extra carriage returns, bullets, automated numbering, symbols, bolding, italics, or any other formatting, that formatting will not be retained when you submit your comments.

- Separate discrete comments by idea, e.g., preface with (1), (2), etc.
- Use brackets [] to call attention to suggested inserted or deleted text.
- Insert a “check” mark in the appropriate boxes by double-clicking the gray areas.
- **Do not use** formatting such as extra carriage returns, bullets, automated numbering, bolding, or italics.
- **Please do not repeat other entity’s comments.** Select the appropriate item to support another entity’s comments. An opportunity to enter additional or exception comments will be available.
- If supporting other’s comments, be sure the other party submits comments.

**Question**

1. The Protection System Response to Power Swings Standard Drafting Team believes it has addressed industry comments in such a manner that industry consensus can be achieved. If there are remaining unresolved issues in the proposed PRC-026-1 Reliability Standard, please provide your comments here:

Comments:

# Violation Risk Factors and Violation Severity Level Justifications

Project 2010-13.3 – Relay Loadability: Stable Power Swings  
(PRC-026-1 – Relay Performance During Stable Power Swings)

## Violation Risk Factor and Violation Severity Level Justifications

This document provides the drafting team's justification for assignment of violation risk factors (VRFs) and violation severity levels (VSLs) for each requirement in: PRC-026-1 – Relay Performance During Stable Power Swings.

Each primary requirement is assigned a VRF and a set of one or more VSLs. These elements support the determination of an initial value range for the Base Penalty Amount regarding violations of requirements in FERC-approved Reliability Standards, as defined in the ERO Sanction Guidelines.

The Protection System Response to Power Swings Standard Drafting Team applied the following NERC criteria and FERC Guidelines when proposing VRFs and VSLs for the requirements under this project.

### **NERC Criteria - Violation Risk Factors**

#### ***High Risk Requirement***

A requirement that, if violated, could directly cause or contribute to bulk electric system instability, separation, or a cascading sequence of failures, or could place the bulk electric system at an unacceptable risk of instability, separation, or cascading failures; or, a requirement in a planning time frame that, if violated, could, under emergency, abnormal, or restorative conditions anticipated by the preparations, directly cause or contribute to bulk electric system instability, separation, or a cascading sequence of failures, or could place the bulk electric system at an unacceptable risk of instability, separation, or cascading failures, or could hinder restoration to a normal condition.

#### ***Medium Risk Requirement***

A requirement that, if violated, could directly affect the electrical state or the capability of the bulk electric system, or the ability to effectively monitor and control the bulk electric system. However, violation of a medium risk requirement is unlikely to lead to bulk electric system instability, separation, or cascading failures; or, a requirement in a planning time frame that, if violated, could, under emergency, abnormal, or restorative conditions anticipated by the preparations, directly and adversely affect the electrical state or capability of the bulk electric system, or the ability to effectively monitor, control, or restore the bulk electric system.

However, violation of a medium risk requirement is unlikely, under emergency, abnormal, or restoration conditions anticipated by the preparations, to lead to bulk electric system instability, separation, or cascading failures, nor to hinder restoration to a normal condition.

### ***Lower Risk Requirement***

A requirement that is administrative in nature and a requirement that, if violated, would not be expected to adversely affect the electrical state or capability of the bulk electric system, or the ability to effectively monitor and control the bulk electric system; or, a requirement that is administrative in nature and a requirement in a planning time frame that, if violated, would not, under the emergency, abnormal, or restorative conditions anticipated by the preparations, be expected to adversely affect the electrical state or capability of the bulk electric system, or the ability to effectively monitor, control, or restore the bulk electric system. A planning requirement that is administrative in nature.

### **FERC Violation Risk Factor Guidelines**

The standard drafting team (SDT) also considered consistency with the FERC Violation Risk Factor Guidelines for setting VRFs:<sup>1</sup>

#### **Guideline (1) — Consistency with the Conclusions of the Final Blackout Report**

The Commission seeks to ensure that Violation Risk Factors assigned to Requirements of Reliability Standards in these identified areas appropriately reflect their historical critical impact on the reliability of the Bulk-Power System.

In the VSL Order, FERC listed critical areas (from the Final Blackout Report) where violations could severely affect the reliability of the Bulk-Power System:<sup>2</sup>

- Emergency operations
- Vegetation management
- Operator personnel training
- Protection systems and their coordination
- Operating tools and backup facilities
- Reactive power and voltage control
- System modeling and data exchange
- Communication protocol and facilities
- Requirements to determine equipment ratings
- Synchronized data recorders
- Clearer criteria for operationally critical facilities
- Appropriate use of transmission loading relief

#### **Guideline (2) — Consistency within a Reliability Standard**

<sup>1</sup> North American Electric Reliability Corp., 119 FERC ¶ 61,145, order on reh'g and compliance filing, 120 FERC ¶ 61,145 (2007) ("VRF Rehearing Order").

<sup>2</sup> Id. at footnote 15.

The Commission expects a rational connection between the sub-Requirement Violation Risk Factor assignments and the main Requirement Violation Risk Factor assignment.

**Guideline (3) – Consistency among Reliability Standards**

The Commission expects the assignment of Violation Risk Factors corresponding to Requirements that address similar reliability goals in different Reliability Standards would be treated comparably.

**Guideline (4) – Consistency with NERC’s Definition of the Violation Risk Factor Level**

Guideline (4) was developed to evaluate whether the assignment of a particular Violation Risk Factor level conforms to NERC’s definition of that risk level.

**Guideline (5) – Treatment of Requirements that Co-mingle More Than One Obligation**

Where a single Requirement co-mingles a higher risk reliability objective and a lesser risk reliability objective, the VRF assignment for such Requirements must not be watered down to reflect the lower risk level associated with the less important objective of the Reliability Standard.

**NERC Criteria - Violation Severity Levels**

Violation Severity Levels (VSLs) define the degree to which compliance with a requirement was not achieved. Each requirement must have at least one VSL. While it is preferable to have four VSLs for each requirement, some requirements do not have multiple “degrees” of noncompliant performance and may have only one, two, or three VSLs.

Violation severity levels should be based on the guidelines shown in the table below:

Lower	Moderate	High	Severe
Missing a minor element (or a small percentage) of the required performance The performance or product measured has significant value as it almost meets the full intent of the requirement.	Missing at least one significant element (or a moderate percentage) of the required performance. The performance or product measured still has significant value in meeting the intent of the requirement.	Missing more than one significant element (or is missing a high percentage) of the required performance or is missing a single vital component. The performance or product has limited value in meeting the intent of the requirement.	Missing most or all of the significant elements (or a significant percentage) of the required performance. The performance measured does not meet the intent of the requirement or the product delivered cannot be used in meeting the intent of the requirement.



***FERC Order on Violation Severity Levels***

In its June 19, 2008 Order on Violation Severity Levels, FERC indicated it would use the following four guidelines for determining whether to approve VSLs:

***Guideline 1: Violation Severity Level Assignments Should Not Have the Unintended Consequence of Lowering the Current Level of Compliance***

Compare the VSLs to any prior Levels of Non-compliance and avoid significant changes that may encourage a lower level of compliance than was required when Levels of Non-compliance were used.

***Guideline 2: Violation Severity Level Assignments Should Ensure Uniformity and Consistency in the Determination of Penalties***

Guideline 2a: A violation of a “binary” type requirement must be a “Severe” VSL.

Guideline 2b: Do not use ambiguous terms such as “minor” and “significant” to describe noncompliant performance.

***Guideline 3: Violation Severity Level Assignment Should Be Consistent with the Corresponding Requirement***

VSLs should not expand on what is required in the requirement.

***Guideline 4: Violation Severity Level Assignment Should Be Based on A Single Violation, Not on A Cumulative Number of Violations***

. . . unless otherwise stated in the requirement, each instance of non-compliance with a requirement is a separate violation. Section 4 of the Sanction Guidelines states that assessing penalties on a per violation per day basis is the “default” for penalty calculations.

VRF and VSL Justifications – PRC-026-1, R1	
Proposed VRF	Medium
NERC VRF Discussion	<p>A Violation Risk Factor of Medium is consistent with the NERC VRF Guidelines:</p> <p>A failure to notify the respective Generator Owner or Transmission Owner of the Element(s) that meet the Requirement R1 criteria prohibits further evaluation of any load-responsive protective relay applied at the terminal of the Element(s). A load-responsive protective relay that goes without evaluation may not be secure for a stable power swing and could in the planning time frame, under emergency, abnormal, or restorative conditions anticipated by the preparations, directly and adversely affect the electrical state or capability of the bulk electric system, or the ability to effectively monitor, control, or restore the bulk electric system.</p> <p>Identifying an Element for notification that is expected to encounter stable power swings based on Requirement R1 criteria is the first step in ensuring the reliable operation of the Bulk Electric System (BES) and in preventing the future severity of disturbances from affecting a wider area.</p>
FERC VRF G1 Discussion	<p>Guideline 1- Consistency w/ Blackout Report:</p> <p>The blackout report and subsequent technical analysis identified that two Bulk Power System (BPS) transmission lines tripped due to protective relay operation in response to stable power swings. The Protection System operations on these lines did not contribute significantly to the overall outcome of the August 14, 2003 system disturbance; however, Protection System operation during stable powers swings could negatively impact system reliability under different operating conditions. Identification and evaluation of BES Elements susceptible to power swings and the subsequent mitigation of load-responsive protective relays applied at the terminals of these BES Elements that do not meet the PRC-026-1 – Attachment B criteria will reduce the likelihood of reoccurrence.</p> <p>This Requirement is consistent with the intent of Recommendation 8: Improve System Protection to Slow or Limit the Spread of Future Cascading Outages. While the actions associated with this recommendation did not focus specifically on the issue of Protection Systems tripping in response to stable power swings, the recommendation does note that “power system protection devices should be set to address the</p>

VRF and VSL Justifications – PRC-026-1, R1	
	specific condition of concern, such as a fault, out-of-step condition, etc., and should not compromise a power system’s inherent physical capability to slow down or stop a cascading event.”
FERC VRF G2 Discussion	<p>Guideline 2- Consistency within a Reliability Standard:</p> <p>The Requirement has a single reliability activity associated with the reliability objective and no sub-Requirement(s) which allows a single VRF to be assigned; therefore no conflict(s) exist.</p>
FERC VRF G3 Discussion	<p>Guideline 3- Consistency among Reliability Standards:</p> <p>The Requirement is consistent with NERC Reliability Standard FAC-014-2, R6 (“...Planning Authority shall identify the subset of multiple contingencies...”) which has a VRF of Medium.</p>
FERC VRF G4 Discussion	<p>Guideline 4- Consistency with NERC Definitions of VRFs:</p> <p>A failure of the Planning Coordinator to notify the respective Generator Owner or Transmission Owner of the BES Element(s) that meet the Requirement R1 criteria prohibits further evaluation of any load-responsive protective relay applied at the terminal of the Element. A load-responsive protective relay that goes without evaluation may not be secure for a stable power swing and could in the planning time frame, under emergency, abnormal, or restorative conditions anticipated by the preparations, directly and adversely affect the electrical state or capability of the bulk electric system, or the ability to effectively monitor, control, or restore the bulk electric system.</p> <p>Identifying an Element for notification that is expected to encounter stable power swings based on the Requirement R1 criteria is the first step in ensuring the reliable operation of the BES and in preventing the future severity of disturbances from affecting a wider area.</p>
FERC VRF G5 Discussion	<p>Guideline 5- Treatment of Requirements that Co-mingle More than One Obligation:</p> <p>This Requirement does not co-mingle reliability objectives of differing risk; therefore, the assigned VRF of Medium is consistent.</p>

VRF and VSL Justifications – PRC-026-1, R1			
Proposed VSL			
Lower	Moderate	High	Severe
The Planning Coordinator provided notification of the BES Element(s) in accordance with Requirement R1, but was less than or equal to 30 calendar days late.	The Planning Coordinator provided notification of the BES Element(s) in accordance with Requirement R1, but was more than 30 calendar days and less than or equal to 60 calendar days late.	The Planning Coordinator provided notification of the BES Element(s) in accordance with Requirement R1, but was more than 60 calendar days and less than or equal to 90 calendar days late.	The Planning Coordinator provided notification of the BES Element(s) in accordance with Requirement R1, but was more than 90 calendar days late.  OR The Planning Coordinator failed to provide notification of the BES Element(s) in accordance with Requirement R1.
NERC VSL Guidelines	Meets NERC’s VSL Guidelines—There is an incremental aspect to the VSL for tardiness and a binary aspect for failure. The VSL is entity size-neutral because performance is Element-driven and not by the total assets which an entity may have awareness over.		
FERC VSL G1 Violation Severity Level Assignments Should Not Have the Unintended Consequence of Lowering the Current Level of Compliance	The proposed VSL does not lower the current level of compliance because the Requirement is new.		

VRF and VSL Justifications – PRC-026-1, R1

<p>FERC VSL G2</p> <p>Violation Severity Level Assignments Should Ensure Uniformity and Consistency in the Determination of Penalties</p> <p>Guideline 2a: The Single Violation Severity Level Assignment Category for "Binary" Requirements Is Not Consistent</p> <p>Guideline 2b: Violation Severity Level Assignments that Contain Ambiguous Language</p>	<p>Guideline 2a:</p> <p>This Requirement is not binary; therefore, this criterion does not apply.</p> <p>Guideline 2b:</p> <p>The proposed VSL does not use any ambiguous terminology, thereby supporting uniformity and consistency in the determination of similar penalties for similar violations.</p>
<p>FERC VSL G3</p> <p>Violation Severity Level Assignment Should Be Consistent with the Corresponding Requirement</p>	<p>The proposed VSL uses similar terminology to that used in the corresponding Requirement, and is therefore consistent with the Requirement.</p>
<p>FERC VSL G4</p> <p>Violation Severity Level Assignment Should Be Based on A Single Violation, Not on A Cumulative Number of Violations</p>	<p>The VSL is based on a single violation and not cumulative violations.</p>

VRF and VSL Justifications – PRC-026-1, R2	
Proposed VRF	High
NERC VRF Discussion	<p>A Violation Risk Factor of High is consistent with the NERC VRF Guidelines:</p> <p>A failure to evaluate the Protection System to determine that it is expected to not trip for a stable power swing for a BES Element could, under emergency, abnormal, or restorative conditions anticipated by the preparations, directly cause or contribute to bulk electric system instability, separation, or a cascading sequence of failures, or could place the bulk electric system at an unacceptable risk of instability, separation, or cascading failures, or could hinder restoration to a normal condition.</p> <p>A Protection System that does not meet the PRC-026-1 – Attachment B criteria is less secure during stable power swings, which increases the risk of tripping should the Protection System be challenged by a power swing.</p>
FERC VRF G1 Discussion	<p>Guideline 1- Consistency w/ Blackout Report:</p> <p>The blackout report and subsequent technical analysis identified that two bulk power system (BPS) transmission lines tripped due to protective relay operation in response to stable power swings. The Protection System operations on these lines did not contribute significantly to the overall outcome of the August 14, 2003 system disturbance; however, Protection System operation during stable powers swings could negatively impact system reliability under different operating conditions. Evaluation of load-responsive protective relays applied at the terminals of identified BES Elements will allow the Generator Owner and Transmission Owner to determine whether the load-responsive protective relays meet the PRC-026-1 – Attachment B criteria.</p> <p>This Requirement is consistent with the intent of Recommendation 8: Improve System Protection to Slow or Limit the Spread of Future Cascading Outages. While the actions associated with this recommendation did not focus specifically on this issue of Protection Systems tripping in response to stable power swings, the recommendation does note that “power system protection devices should be set to address the specific condition of concern, such as a fault, out-of-step condition, etc., and should not compromise a power system’s inherent physical capability to slow down or stop a cascading event.”</p>

VRF and VSL Justifications – PRC-026-1, R2	
FERC VRF G2 Discussion	<p>Guideline 2- Consistency within a Reliability Standard:</p> <p>The Requirement has a single reliability activity associated with the reliability objective and no sub-Requirement(s) which allows a single VRF to be assigned; therefore no conflict(s) exist.</p>
FERC VRF G3 Discussion	<p>Guideline 3- Consistency among Reliability Standards:</p> <p>The Requirement is consistent with NERC Reliability Standard PRC-023-3, R1 (“...Each Transmission Owner, Generator Owner, and Distribution Provider shall evaluate relay loadability at 0.85 per unit voltage and a power factor angle of 30 degrees”) which has a VRF of High.</p>
FERC VRF G4 Discussion	<p>Guideline 4- Consistency with NERC Definitions of VRFs:</p> <p>A failure of the Generator Owner or Transmission Owner to evaluate that the Protection System is expected to not trip in response to a stable power swing during a non-Fault condition for a BES Element could, under emergency, abnormal, or restorative conditions anticipated by the preparations, directly cause or contribute to bulk electric system instability, separation, or a cascading sequence of failures, or could place the bulk electric system at an unacceptable risk of instability, separation, or cascading failures, or could hinder restoration to a normal condition.</p> <p>A Protection System that does not meet the PRC-026-1 – Attachment B criteria is less secure during stable power swings, it increases the risk of tripping should the Protection System be challenged by a power swing.</p>
FERC VRF G5 Discussion	<p>Guideline 5- Treatment of Requirements that Co-mingle More than One Obligation:</p> <p>This Requirement does not co-mingle reliability objectives of differing risk; therefore, the assigned VRF of Medium is consistent.</p>

VRF and VSL Justifications – PRC-026-1, R2			
Proposed VSL			
Lower	Moderate	High	Severe
The Generator Owner or Transmission Owner evaluated its load-responsive protective relay(s) in accordance with Requirement R2, but was less than or equal to 30 calendar days late.	The Generator Owner or Transmission Owner evaluated its load-responsive protective relay(s) in accordance with Requirement R2, but was more than 30 calendar days and less than or equal to 60 calendar days late.	The Generator Owner or Transmission Owner evaluated its load-responsive protective relay(s) in accordance with Requirement R2, but was more than 60 calendar days and less than or equal to 90 calendar days late.	The Generator Owner or Transmission Owner evaluated its load-responsive protective relay(s) in accordance with Requirement R2, but was more than 90 calendar days late.  OR The Generator Owner or Transmission Owner failed to evaluate its load-responsive protective relay(s) in accordance with Requirement R2.
NERC VSL Guidelines	Meets NERC’s VSL Guidelines—There is an incremental aspect to the VSL for tardiness and a binary aspect for failure. The VSL is entity size-neutral because performance is driven by exception. For example, each identified Element must be evaluated.		
FERC VSL G1 Violation Severity Level Assignments Should Not Have the Unintended Consequence of Lowering the Current Level of Compliance	The proposed VSL does not lower the current level of compliance because the Requirement is new.		



VRF and VSL Justifications – PRC-026-1, R2

<p>FERC VSL G2</p> <p>Violation Severity Level Assignments Should Ensure Uniformity and Consistency in the Determination of Penalties</p> <p>Guideline 2a: The Single Violation Severity Level Assignment Category for "Binary" Requirements Is Not Consistent</p> <p>Guideline 2b: Violation Severity Level Assignments that Contain Ambiguous Language</p>	<p>Guideline 2a:</p> <p>This Requirement is not binary; therefore, this criterion does not apply.</p> <p>Guideline 2b:</p> <p>The proposed VSL does not use any ambiguous terminology, thereby supporting uniformity and consistency in the determination of similar penalties for similar violations.</p>
<p>FERC VSL G3</p> <p>Violation Severity Level Assignment Should Be Consistent with the Corresponding Requirement</p>	<p>The proposed VSL uses similar terminology to that used in the corresponding Requirement, and is therefore consistent with the Requirement.</p>
<p>FERC VSL G4</p> <p>Violation Severity Level Assignment Should Be Based on A Single Violation, Not on A Cumulative Number of Violations</p>	<p>The VSL is based on a single violation and not cumulative violations.</p>

VRF and VSL Justifications – PRC-004-3, R3

Proposed VRF	Medium
<p>NERC VRF Discussion</p>	<p>A Violation Risk Factor of Medium is consistent with the NERC VRF Guidelines:</p> <p>Failure to develop a Corrective Action Plan (CAP) such that the Protection System of a BES Element will meet the PRC-026-1 – Attachment B criteria or to exclude the Protection System under the PRC-026-1 – Attachment A criteria (e.g., modifying the Protection System so that relay functions are supervised by power swing blocking or using relay systems that are immune to power swings) could in the planning time frame, under emergency, abnormal, or restorative conditions anticipated by the preparations, directly and adversely affect the electrical state or capability of the bulk electric system, or the ability to effectively monitor, control, or restore the bulk electric system.</p> <p>An unmitigated Protection System could affect the electrical state or capability of the bulk electric system, or the ability to effectively monitor, control, or restore the bulk electric system.</p>
<p>FERC VRF G1 Discussion</p>	<p>Guideline 1- Consistency w/ Blackout Report:</p> <p>The blackout report and subsequent technical analysis identified that two bulk power system (BPS) transmission lines tripped due to protective relay operation in response to stable power swings. The Protection System operations on these lines did not contribute significantly to the overall outcome of the August 14, 2003 system disturbance; however, Protection System operation during stable powers swings could negatively impact system reliability under different operating conditions. Developing a CAP such that the Protection System will meet the Attachment B criteria or to exclude the Protection System under the PRC-026-1 – Attachment A criteria (e.g., modifying the Protection System so that relay functions are supervised by power swing blocking or using relay systems that are immune to power swings) applied at the terminals of BES Elements will reduce the likelihood of reoccurrence.</p>

VRF and VSL Justifications – PRC-004-3, R3	
	<p>This Requirement is consistent with the intent of Recommendation 8: Improve System Protection to Slow or Limit the Spread of Future Cascading Outages. While the actions associated with this recommendation did not focus specifically on this issue of Protection Systems tripping in response to stable power swings, the recommendation does note that “power system protection devices should be set to address the specific condition of concern, such as a fault, out-of-step condition, etc., and should not compromise a power system’s inherent physical capability to slow down or stop a cascading event.”</p>
FERC VRF G2 Discussion	<p>Guideline 2- Consistency within a Reliability Standard:</p> <p>This Requirement has a single reliability activity associated with the reliability objective and no sub-Requirement(s) which allows a single VRF to be assigned; therefore no conflict(s) exist.</p>
FERC VRF G3 Discussion	<p>Guideline 3- Consistency among Reliability Standards:</p> <p>This Requirement is consistent with the following Reliability Standards which requiring corrective actions (e.g., Corrective Action Plans); PRC-016-0.1, R2 (“...shall take corrective actions to avoid future Misoperations”), PRC-022-1, R1.5 (“For any Misoperation, a Corrective Action Plan...”), and FAC-003, R5 (“...Transmission Owner or applicable Generator Owner shall take corrective action to ensure continued vegetation management”) all three of which have a VRF of Medium.</p>
FERC VRF G4 Discussion	<p>Guideline 4- Consistency with NERC Definitions of VRFs:</p> <p>A Violation Risk Factor of Medium is consistent with the NERC VRF Guidelines:</p> <p>A failure to develop the Corrective Action Plan (CAP) such that the Protection System of a BES Element will meet the Attachment B criteria or to exclude the Protection System under the PRC-026-1 – Attachment A criteria (e.g., modifying the Protection System so that relay functions are supervised by power swing blocking or using relay systems that are immune to power swings) could in the planning time frame, under emergency, abnormal, or restorative conditions anticipated by the preparations, directly and adversely affect the electrical state or capability of the bulk electric system, or the ability to effectively monitor, control, or restore the bulk electric system.</p>

VRF and VSL Justifications – PRC-004-3, R3			
	An unmitigated Protection System could contribute to the severity of future disturbances affecting a wider area, or potential equipment damage.		
FERC VRF G5 Discussion	Guideline 5- Treatment of Requirements that Co-mingle More than One Obligation:  This requirement does not co-mingle reliability objectives of differing risk; therefore, the assigned VRF of Medium is consistent.		
Proposed VSL			
Lower	Moderate	High	Severe
The Generator Owner or Transmission Owner developed a Corrective Action Plan (CAP) in accordance with Requirement R3, but in more than six calendar months and less than or equal to seven calendar months.	The Generator Owner or Transmission Owner developed a Corrective Action Plan (CAP) in accordance with Requirement R3, but in more than seven calendar months and less than or equal to eight calendar months.	The Generator Owner or Transmission Owner developed a Corrective Action Plan (CAP) in accordance with Requirement R3, but in more than eight calendar months and less than or equal to nine calendar months.	The Generator Owner or Transmission Owner developed a Corrective Action Plan (CAP) in accordance with Requirement R3, but in more than nine calendar months.  OR  The Generator Owner or Transmission Owner failed to develop a CAP in accordance with Requirement R3.
NERC VSL Guidelines	Meets NERC’s VSL Guidelines—There is an incremental aspect to the VSL for failing to develop the Corrective Action Plan in a timely fashion and a binary aspect for a complete failure. The VSL is entity size-neutral because performance is driven by the need to mitigate the Protection System so that it is expected to not trip on a stable power swing.		

VRF and VSL Justifications – PRC-004-3, R3

<p>FERC VSL G1</p> <p>Violation Severity Level Assignments Should Not Have the Unintended Consequence of Lowering the Current Level of Compliance</p>	<p>The proposed VSL does not lower the current level of compliance because the Requirement is new.</p>
<p>FERC VSL G2</p> <p>Violation Severity Level Assignments Should Ensure Uniformity and Consistency in the Determination of Penalties</p> <p>Guideline 2a: The Single Violation Severity Level Assignment Category for "Binary" Requirements Is Not Consistent</p> <p>Guideline 2b: Violation Severity Level Assignments that Contain Ambiguous Language</p>	<p>Guideline 2a:</p> <p>This Requirement is not binary; therefore, this criterion does not apply.</p> <p>Guideline 2b:</p> <p>This proposed VSL does not use any ambiguous terminology, thereby supporting uniformity and consistency in the determination of similar penalties for similar violations.</p>
<p>FERC VSL G3</p> <p>Violation Severity Level Assignment Should Be Consistent with the Corresponding Requirement</p>	<p>This proposed VSL uses similar terminology to that used in the corresponding Requirement, and is therefore consistent with this Requirement.</p>
<p>FERC VSL G4</p>	<p>The VSL is based on a single violation and not cumulative violations.</p>

**VRF and VSL Justifications – PRC-004-3, R3**

<p>Violation Severity Level Assignment Should Be Based on A Single Violation, Not on A Cumulative Number of Violations</p>	
----------------------------------------------------------------------------------------------------------------------------	--

**VRF and VSL Justifications – PRC-026-1, R4**

Proposed VRF	Medium
NERC VRF Discussion	<p>A Violation Risk Factor of Medium is consistent with the NERC VRF Guidelines:</p> <p>A failure to implement the Corrective Action Plan (CAP) to meet the PRC-026-1 – Attachment B criteria or to exclude the Protection System under the PRC-026-1 – Attachment A criteria (e.g., modifying the Protection System so that relay functions are supervised by power swing blocking or using relay systems that are immune to power swings) could in the planning time frame, under emergency, abnormal, or restorative conditions anticipated by the preparations, directly and adversely affect the electrical state or capability of the bulk electric system, or the ability to effectively monitor, control, or restore the bulk electric system.</p> <p>An unmitigated Protection System could affect the electrical state or capability of the bulk electric system, or the ability to effectively monitor, control, or restore the bulk electric system.</p>
FERC VRF G1 Discussion	<p>Guideline 1- Consistency w/ Blackout Report:</p> <p>The blackout report and subsequent technical analysis identified that two bulk power system (BPS) transmission lines tripped due to protective relay operation in response to stable power swings. The Protection System operations on these lines did not contribute significantly to the overall outcome of the August 14, 2003 system disturbance; however, Protection System operation during stable powers swings</p>

VRF and VSL Justifications – PRC-026-1, R4	
	<p>could negatively impact system reliability under different operating conditions. Implementing a CAP such that the Protection System will meet the Attachment B criteria or to exclude the Protection System under the PRC-026-1 – Attachment A criteria (e.g., modifying the Protection System so that relay functions are supervised by power swing blocking or using relay systems that are immune to power swings) applied at the terminals of these Elements will reduce the likelihood of reoccurrence.</p> <p>This Requirement is consistent with the intent of Recommendation 8: Improve System Protection to Slow or Limit the Spread of Future Cascading Outages. While the actions associated with this recommendation did not focus specifically on this issue of Protection Systems tripping in response to stable power swings, the recommendation does note that “power system protection devices should be set to address the specific condition of concern, such as a fault, out-of-step condition, etc., and should not compromise a power system’s inherent physical capability to slow down or stop a cascading event.”</p>
FERC VRF G2 Discussion	<p>Guideline 2- Consistency within a Reliability Standard:</p> <p>The Requirement has a single reliability activity associated with the reliability objective and no sub-Requirement(s) which allows a single VRF to be assigned; therefore no conflict(s) exist.</p>
FERC VRF G3 Discussion	<p>Guideline 3- Consistency among Reliability Standards:</p> <p>This Requirement is consistent with the following Reliability Standards which requiring corrective actions (e.g., Corrective Action Plans): PRC-016-0.1, R2 (“...shall take corrective actions to avoid future Misoperations”), PRC-022-1, R1.5 (“For any Misoperation, a Corrective Action Plan...”), and FAC-003, R5 (“...Transmission Owner or applicable Generator Owner shall take corrective action to ensure continued vegetation management”) all of which have a VRF of Medium.</p>
FERC VRF G4 Discussion	<p>A Violation Risk Factor of Medium is consistent with the NERC VRF Guidelines:</p> <p>A failure to implement the Corrective Action Plan such that the Protection System of a BES Element will meet the Attachment B criteria or to exclude the Protection System under the PRC-026-1 – Attachment A criteria (e.g., modifying the Protection System so that relay functions are supervised by power swing blocking or using relay systems that are immune to power swings) could in the planning time frame, under emergency, abnormal, or restorative conditions anticipated by the preparations, directly and adversely</p>

VRF and VSL Justifications – PRC-026-1, R4			
	<p>affect the electrical state or capability of the bulk electric system, or the ability to effectively monitor, control, or restore the bulk electric system.</p> <p>An unmitigated Protection System could contribute to the severity of future disturbances affecting a wider area, or potential equipment damage.</p>		
FERC VRF G5 Discussion	<p>Guideline 5- Treatment of Requirements that Co-mingle More than One Obligation:</p> <p>This Requirement does not co-mingle reliability objectives of differing risk; therefore, the assigned VRF of Medium is consistent.</p>		
Proposed VSL			
Lower	Moderate	High	Severe
The responsible entity implemented, but failed to update a CAP, when actions or timetables changed, in accordance with Requirement R4.	N/A	N/A	The responsible entity failed to implement a CAP in accordance with Requirement R4.
NERC VSL Guidelines	<p>Meets NERC’s VSL Guidelines—There is an incremental aspect to the VSL for failing to update the Corrective Action Plan and a binary aspect for failure to implement. The VSL is entity size-neutral because performance is driven by the need to mitigate the Protection System so that it is expected to not trip on a stable power swing.</p>		
FERC VSL G1 Violation Severity Level Assignments Should Not Have	<p>The proposed VSL does not lower the current level of compliance because the Requirement is new.</p>		



VRF and VSL Justifications – PRC-026-1, R4

<p>the Unintended Consequence of Lowering the Current Level of Compliance</p>	
<p>FERC VSL G2 Violation Severity Level Assignments Should Ensure Uniformity and Consistency in the Determination of Penalties Guideline 2a: The Single Violation Severity Level Assignment Category for "Binary" Requirements Is Not Consistent Guideline 2b: Violation Severity Level Assignments that Contain Ambiguous Language</p>	<p>Guideline 2a: This Requirement is not binary; therefore, this criterion does not apply.  Guideline 2b: The proposed VSL does not use any ambiguous terminology, thereby supporting uniformity and consistency in the determination of similar penalties for similar violations.</p>
<p>FERC VSL G3 Violation Severity Level Assignment Should Be Consistent with the Corresponding Requirement</p>	<p>The proposed VSL uses similar terminology to that used in the corresponding Requirement, and is therefore consistent with the Requirement.</p>
<p>FERC VSL G4 Violation Severity Level Assignment Should Be Based on A Single Violation, Not on A</p>	<p>The VSL is based on a single violation and not cumulative violations.</p>

VRF and VSL Justifications – PRC-026-1, R4

Cumulative Number of Violations	
---------------------------------	--

# Violation Risk Factors and Violation Severity Level Justifications

Project 2010-13.3 – Relay Loadability: Stable Power Swings  
(PRC-026-1 – Relay Performance During Stable Power Swings)

## Violation Risk Factor and Violation Severity Level Justifications

This document provides the drafting team's justification for assignment of violation risk factors (VRFs) and violation severity levels (VSLs) for each requirement in: PRC-026-1 – Relay Performance During Stable Power Swings.

Each primary requirement is assigned a VRF and a set of one or more VSLs. These elements support the determination of an initial value range for the Base Penalty Amount regarding violations of requirements in FERC-approved Reliability Standards, as defined in the ERO Sanction Guidelines.

The Protection System Response to Power Swings Standard Drafting Team applied the following NERC criteria and FERC Guidelines when proposing VRFs and VSLs for the requirements under this project.

### **NERC Criteria - Violation Risk Factors**

#### ***High Risk Requirement***

A requirement that, if violated, could directly cause or contribute to bulk electric system instability, separation, or a cascading sequence of failures, or could place the bulk electric system at an unacceptable risk of instability, separation, or cascading failures; or, a requirement in a planning time frame that, if violated, could, under emergency, abnormal, or restorative conditions anticipated by the preparations, directly cause or contribute to bulk electric system instability, separation, or a cascading sequence of failures, or could place the bulk electric system at an unacceptable risk of instability, separation, or cascading failures, or could hinder restoration to a normal condition.

#### ***Medium Risk Requirement***

A requirement that, if violated, could directly affect the electrical state or the capability of the bulk electric system, or the ability to effectively monitor and control the bulk electric system. However, violation of a medium risk requirement is unlikely to lead to bulk electric system instability, separation, or cascading failures; or, a requirement in a planning time frame that, if violated, could, under emergency, abnormal, or restorative conditions anticipated by the preparations, directly and adversely affect the electrical state or capability of the bulk electric system, or the ability to effectively monitor, control, or restore the bulk electric system.

However, violation of a medium risk requirement is unlikely, under emergency, abnormal, or restoration conditions anticipated by the preparations, to lead to bulk electric system instability, separation, or cascading failures, nor to hinder restoration to a normal condition.

### ***Lower Risk Requirement***

A requirement that is administrative in nature and a requirement that, if violated, would not be expected to adversely affect the electrical state or capability of the bulk electric system, or the ability to effectively monitor and control the bulk electric system; or, a requirement that is administrative in nature and a requirement in a planning time frame that, if violated, would not, under the emergency, abnormal, or restorative conditions anticipated by the preparations, be expected to adversely affect the electrical state or capability of the bulk electric system, or the ability to effectively monitor, control, or restore the bulk electric system. A planning requirement that is administrative in nature.

### **FERC Violation Risk Factor Guidelines**

The standard drafting team (SDT) also considered consistency with the FERC Violation Risk Factor Guidelines for setting VRFs:<sup>1</sup>

#### **Guideline (1) — Consistency with the Conclusions of the Final Blackout Report**

The Commission seeks to ensure that Violation Risk Factors assigned to Requirements of Reliability Standards in these identified areas appropriately reflect their historical critical impact on the reliability of the Bulk-Power System.

In the VSL Order, FERC listed critical areas (from the Final Blackout Report) where violations could severely affect the reliability of the Bulk-Power System:<sup>2</sup>

- Emergency operations
- Vegetation management
- Operator personnel training
- Protection systems and their coordination
- Operating tools and backup facilities
- Reactive power and voltage control
- System modeling and data exchange
- Communication protocol and facilities
- Requirements to determine equipment ratings
- Synchronized data recorders
- Clearer criteria for operationally critical facilities
- Appropriate use of transmission loading relief

#### **Guideline (2) — Consistency within a Reliability Standard**

<sup>1</sup> North American Electric Reliability Corp., 119 FERC ¶ 61,145, order on reh'g and compliance filing, 120 FERC ¶ 61,145 (2007) ("VRF Rehearing Order").

<sup>2</sup> Id. at footnote 15.

The Commission expects a rational connection between the sub-Requirement Violation Risk Factor assignments and the main Requirement Violation Risk Factor assignment.

**Guideline (3) – Consistency among Reliability Standards**

The Commission expects the assignment of Violation Risk Factors corresponding to Requirements that address similar reliability goals in different Reliability Standards would be treated comparably.

**Guideline (4) – Consistency with NERC’s Definition of the Violation Risk Factor Level**

Guideline (4) was developed to evaluate whether the assignment of a particular Violation Risk Factor level conforms to NERC’s definition of that risk level.

**Guideline (5) – Treatment of Requirements that Co-mingle More Than One Obligation**

Where a single Requirement co-mingles a higher risk reliability objective and a lesser risk reliability objective, the VRF assignment for such Requirements must not be watered down to reflect the lower risk level associated with the less important objective of the Reliability Standard.

**NERC Criteria - Violation Severity Levels**

Violation Severity Levels (VSLs) define the degree to which compliance with a requirement was not achieved. Each requirement must have at least one VSL. While it is preferable to have four VSLs for each requirement, some requirements do not have multiple “degrees” of noncompliant performance and may have only one, two, or three VSLs.

Violation severity levels should be based on the guidelines shown in the table below:

Lower	Moderate	High	Severe
Missing a minor element (or a small percentage) of the required performance The performance or product measured has significant value as it almost meets the full intent of the requirement.	Missing at least one significant element (or a moderate percentage) of the required performance. The performance or product measured still has significant value in meeting the intent of the requirement.	Missing more than one significant element (or is missing a high percentage) of the required performance or is missing a single vital component. The performance or product has limited value in meeting the intent of the requirement.	Missing most or all of the significant elements (or a significant percentage) of the required performance. The performance measured does not meet the intent of the requirement or the product delivered cannot be used in meeting the intent of the requirement.

***FERC Order on Violation Severity Levels***

In its June 19, 2008 Order on Violation Severity Levels, FERC indicated it would use the following four guidelines for determining whether to approve VSLs:

***Guideline 1: Violation Severity Level Assignments Should Not Have the Unintended Consequence of Lowering the Current Level of Compliance***

Compare the VSLs to any prior Levels of Non-compliance and avoid significant changes that may encourage a lower level of compliance than was required when Levels of Non-compliance were used.

***Guideline 2: Violation Severity Level Assignments Should Ensure Uniformity and Consistency in the Determination of Penalties***

Guideline 2a: A violation of a “binary” type requirement must be a “Severe” VSL.

Guideline 2b: Do not use ambiguous terms such as “minor” and “significant” to describe noncompliant performance.

***Guideline 3: Violation Severity Level Assignment Should Be Consistent with the Corresponding Requirement***

VSLs should not expand on what is required in the requirement.

***Guideline 4: Violation Severity Level Assignment Should Be Based on A Single Violation, Not on A Cumulative Number of Violations***

. . . unless otherwise stated in the requirement, each instance of non-compliance with a requirement is a separate violation. Section 4 of the Sanction Guidelines states that assessing penalties on a per violation per day basis is the “default” for penalty calculations.

VRF and VSL Justifications – PRC-026-1, R1	
Proposed VRF	Medium
NERC VRF Discussion	<p>A Violation Risk Factor of Medium is consistent with the NERC VRF Guidelines:</p> <p>A failure to <del>identify and</del> <u>notify the respective Generator Owner or Transmission Owner of the Element meeting(s) that meet</u> the <u>Requirement R1</u> criteria prohibits further evaluation of any load-responsive protective relay applied at the terminal of the Element-<del>(s)</del>. A load-responsive protective relay that goes without evaluation may not be secure for a stable power swing and could in the planning time frame, under emergency, abnormal, or restorative conditions anticipated by the preparations, directly and adversely affect the electrical state or capability of the bulk electric system, or the ability to effectively monitor, control, or restore the bulk electric system.</p> <p>Identifying an Element <u>for notification</u> that is expected to encounter stable power swings based on <del>prescribed</del> <u>Requirement R1</u> criteria is the first step in ensuring the reliable operation of the <u>Bulk Electric System (BES)</u> and in preventing the future severity of <del>Disturbances</del> <u>disturbances</u> from affecting a wider area.</p>
FERC VRF G1 Discussion	<p>Guideline 1- Consistency w/ Blackout Report:</p> <p>The blackout report and subsequent technical analysis identified that two <u>Bulk Power System (BPS)</u> transmission lines tripped due to protective relay operation in response to stable power swings. -The <del>protection system</del> <u>Protection System</u> operations on these lines did not contribute significantly to the overall outcome of the August 14, 2003 system disturbance; however, <del>protection system</del> <u>Protection System</u> operation during stable powers swings could negatively impact system reliability under different operating conditions. -<del>Identifying</del> <u>Identification and evaluation of BES</u> Elements <del>prone</del> <u>susceptible</u> to power swings and the subsequent mitigation of load-responsive protective relays applied at the terminals of these <u>BES</u> Elements <u>that do not meet the PRC-026-1 – Attachment B criteria</u> will reduce the likelihood of reoccurrence.</p> <p>This Requirement is consistent with the intent of Recommendation 8: Improve System Protection to Slow or Limit the Spread of Future Cascading Outages. -While the actions associated with this recommendation did not focus specifically on <del>this</del> <u>the issue of Protection Systems tripping in response to stable power</u></p>

VRF and VSL Justifications – PRC-026-1, R1	
	<u>swings</u> , the recommendation does note that “power system protection devices should be set to address the specific condition of concern, such as a fault, out-of-step condition, etc., and should not compromise a power system’s inherent physical capability to slow down or stop a cascading event.”
FERC VRF G2 Discussion	Guideline 2- Consistency within a Reliability Standard: The Requirement has a single reliability activity associated with the reliability objective and no sub-Requirement(s) which allows a single VRF to be assigned; therefore no conflict(s) exist.
FERC VRF G3 Discussion	Guideline 3- Consistency among Reliability Standards: The Requirement is consistent with NERC Reliability <del>Standards</del> <u>Standard</u> FAC-014-2, R6 (“...Planning Authority shall identify the subset of multiple contingencies...”) which has a VRF of Medium.
FERC VRF G4 Discussion	Guideline 4- Consistency with NERC Definitions of VRFs: <del>A failure to identify an Element meeting the</del> <u>A failure of the Planning Coordinator to notify the respective Generator Owner or Transmission Owner of the BES Element(s) that meet the Requirement R1</u> criteria prohibits further evaluation of any load-responsive protective relay applied at the terminal of the Element. A load-responsive protective relay that goes without evaluation may not be secure for a stable power swing and could in the planning time frame, under emergency, abnormal, or restorative conditions anticipated by the preparations, directly and adversely affect the electrical state or capability of the bulk electric system, or the ability to effectively monitor, control, or restore the bulk electric system. Identifying an Element <u>for notification</u> that is expected to encounter stable power swings based on <del>prescribed</del> <u>the Requirement R1</u> criteria is the first step in ensuring the reliable operation of the BES and in preventing the future severity of <del>Disturbances</del> <u>disturbances</u> from affecting a wider area.
FERC VRF G5 Discussion	Guideline 5- Treatment of Requirements that Co-mingle More than One Obligation: This Requirement does not co-mingle reliability objectives of differing risk; therefore, the assigned VRF of Medium is consistent.



VRF and VSL Justifications – PRC-026-1, R1

Proposed VSL

Lower	Moderate	High	Severe
<p>The Planning Coordinator <del>identified an Element and</del> provided notification <u>of the BES Element(s)</u> in accordance with Requirement R1, but was less than or equal to 30 calendar days late.</p>	<p>The Planning Coordinator <del>identified an Element and</del> provided notification <u>of the BES Element(s)</u> in accordance with Requirement R1, but was more than 30 calendar days and less than or equal to 60 calendar days late.</p>	<p>The Planning Coordinator <del>identified an Element and</del> provided notification <u>of the BES Element(s)</u> in accordance with Requirement R1, but was more than 60 calendar days and less than or equal to 90 calendar days late.</p>	<p>The Planning Coordinator <del>identified an Element and</del> provided notification <u>of the BES Element(s)</u> in accordance with Requirement R1, but was more than 90 calendar days late.</p> <p>OR</p> <p>The Planning Coordinator failed to <del>identify an</del> <u>provide notification of the BES Element(s)</u> in accordance with Requirement R1.</p> <p><del>OR</del></p> <p><del>The Planning Coordinator failed to provide notification in accordance with Requirement R1.</del></p>
<p>NERC VSL Guidelines</p>	<p>Meets NERC’s VSL Guidelines—There is an incremental aspect to the VSL for tardiness and a binary aspect for failure. The VSL is entity size-neutral because performance is Element-driven and not by the total assets which an entity may have awareness over.</p>		
<p>FERC VSL G1 Violation Severity Level Assignments Should Not Have</p>	<p>The proposed VSL does not lower the current level of compliance because the Requirement is new.</p>		

VRF and VSL Justifications – PRC-026-1, R1

<p>the Unintended Consequence of Lowering the Current Level of Compliance</p>	
<p>FERC VSL G2 Violation Severity Level Assignments Should Ensure Uniformity and Consistency in the Determination of Penalties Guideline 2a: The Single Violation Severity Level Assignment Category for "Binary" Requirements Is Not Consistent Guideline 2b: Violation Severity Level Assignments that Contain Ambiguous Language</p>	<p>Guideline 2a: This Requirement is not binary; therefore, this criterion does not apply.  Guideline 2b: The proposed VSL does not use any ambiguous terminology, thereby supporting uniformity and consistency in the determination of similar penalties for similar violations.</p>
<p>FERC VSL G3 Violation Severity Level Assignment Should Be Consistent with the Corresponding Requirement</p>	<p>The proposed VSL uses similar terminology to that used in the corresponding Requirement, and is therefore consistent with the Requirement.</p>
<p>FERC VSL G4 Violation Severity Level Assignment Should Be Based on A Single Violation, Not on A</p>	<p>The VSL is based on a single violation and not cumulative violations.</p>

VRF and VSL Justifications – PRC-026-1, R1

Cumulative Number of Violations	
---------------------------------	--

VRF and VSL Justifications – PRC-026-1, R2 ~~and R3~~

Proposed VRF	<del>High</del> <u>Medium</u>
NERC VRF Discussion	<p>A Violation Risk Factor of <del>Medium</del> <u>High</u> is consistent with the NERC VRF Guidelines:</p> <p>A failure to <del>identify an Element meeting evaluate</del> the <del>criteria prohibits further evaluation of any load-responsive protective relay applied at the terminal of the Element. A load-responsive protective relay</del> <u>Protection System to determine</u> that <del>goes without evaluation may it is expected to not be secure trip</del> for a stable power swing <del>and for a BES Element</del> <u>could in the planning time frame</u>, under emergency, abnormal, or restorative conditions anticipated by the preparations, directly <del>and adversely affect the electrical state cause</del> or <del>capability of the contribute to</del> bulk electric system <u>instability, separation</u>, or <del>the ability to effectively monitor, control a cascading sequence of failures, or restore could place</del> the bulk electric system <u>at an unacceptable risk of instability, separation, or cascading failures, or could hinder restoration to a normal condition.</u></p> <p><del>Identifying an Element</del> <u>A Protection System</u> that <del>is expected to encounter</del> <u>does not meet the PRC-026-1 – Attachment B criteria is less secure during</u> stable power swings <del>based on prescribed criteria is the first step in ensuring, which increases the reliable operation risk of tripping should the BES and in preventing the future severity of Disturbances from affecting</del> <u>Protection System be challenged by a wider area power swing.</u></p>
FERC VRF G1 Discussion	<p>Guideline 1- Consistency w/ Blackout Report:</p> <p>The blackout report and subsequent technical analysis identified that two <u>bulk power system (BPS)</u> transmission lines tripped due to protective relay operation in response to stable power swings. <del>The protection system</del> <u>Protection System</u> operations on these lines did not contribute significantly to the overall outcome of the August 14, 2003 system disturbance; however, <del>protection system</del> <u>Protection</u></p>

VRF and VSL Justifications – PRC-026-1, R2 and R3

	<p><u>System</u> operation during stable powers swings could negatively impact system reliability under different operating conditions. <del>Identifying Elements prone to power swings and the subsequent mitigation</del><u>Evaluation</u> of load-responsive protective relays applied at the terminals of <del>these</del><u>identified BES</u> Elements will <del>reduce</del><u>allow the Generator Owner and Transmission Owner to determine whether</u> the <del>likelihood of reoccurrence.</del><u>load-responsive protective relays meet the PRC-026-1 – Attachment B criteria.</u></p> <p>This Requirement is consistent with the intent of Recommendation 8: Improve System Protection to Slow or Limit the Spread of Future Cascading Outages. -While the actions associated with this recommendation did not focus specifically on this issue <u>of Protection Systems tripping in response to stable power swings</u>, the recommendation does note that “power system protection devices should be set to address the specific condition of concern, such as a fault, out-of-step condition, etc., and should not compromise a power system’s inherent physical capability to slow down or stop a cascading event.”</p>
<p><del>FERC VRF G2 Discussion</del></p>	<p><del>Guideline 2 – Consistency within a Reliability Standard: The Requirement has a single reliability activity associated with the reliability objective and no sub-Requirement(s) which allows a single VRF to be assigned; therefore no conflict(s) exist.</del></p>
<p><del>FERC VRF G3 Discussion</del></p>	<p><del>Guideline 3 – Consistency among Reliability Standards:</del></p>
<p><del>FERC VRF G4 Discussion</del></p>	<p><del>Guideline 4 – Consistency with NERC Definitions of VRFs: A failure to identify an Element meeting the criteria prohibits further evaluation of any load responsive protective relay applied at the terminal of the Element. A load responsive protective relay that goes without evaluation may not be secure for a stable power swing and could in the planning time frame, under emergency, abnormal, or restorative conditions anticipated by the preparations, directly and adversely affect the electrical state or capability of the bulk electric system, or the ability to effectively monitor, control, or restore the bulk electric system. Identifying an Element that is expected to encounter stable power swings based on prescribed criteria is the first step in ensuring the reliable operation of the BES and in preventing the future severity of Disturbances from affecting a wider area.</del></p>
<p><del>FERC VRF G5 Discussion</del></p>	<p><del>Guideline 5 – Treatment of Requirements that Co-mingle More than One Obligation: This Requirement does not co-mingle reliability objectives of differing risk; therefore, the assigned VRF of Medium is consistent.</del></p>

VRF and VSL Justifications – PRC-026-1, R2 and R3

Proposed VSL

Lower	Moderate	High	Severe
<p>The Transmission Owner identified an Element and provided notification in accordance with Requirement R2, but was less than or equal to 10 calendar days late.</p>	<p>The Transmission Owner identified an Element and provided notification in accordance with Requirement R2, but was more than 10 calendar days and less than or equal to 20 calendar days late.</p>	<p>The Transmission Owner identified an Element and provided notification in accordance with Requirement R2, but was more than 20 calendar days and less than or equal to 30 calendar days late.</p>	<p>The Transmission Owner identified an Element and provided notification in accordance with Requirement R2, but was more than 30 calendar days late.</p> <p>OR</p> <p>The Transmission Owner failed to identify an Element in accordance with Requirement R2.</p> <p>OR</p> <p>The Transmission Owner failed to provide notification in accordance with Requirement R2.</p>
<p>NERC VSL Guidelines</p>	<p>Meets NERC's VSL Guidelines — There is an incremental aspect to the VSL for tardiness and a binary aspect for failure. The VSL is entity size neutral because performance is Element driven and not by the total assets which an entity may have awareness over.</p>		
<p>FERC VSL G1 Violation Severity Level Assignments Should Not Have the Unintended Consequence of Lowering the Current Level of Compliance</p>	<p>The proposed VSL does not lower the current level of compliance because the Requirement is new.</p>		

VRF and VSL Justifications – PRC-026-1, R2 and R3

<p><del>FERC VSL G2 Violation Severity Level Assignments Should Ensure Uniformity and Consistency in the Determination of Penalties Guideline 2a: The Single Violation Severity Level Assignment Category for "Binary" Requirements Is Not Consistent Guideline 2b: Violation Severity Level Assignments that Contain Ambiguous Language</del></p>	<p><del>Guideline 2a: This Requirement is not binary; therefore, this criterion does not apply.</del></p> <p><del>Guideline 2b: The proposed VSL does not use any ambiguous terminology, thereby supporting uniformity and consistency in the determination of similar penalties for similar violations.</del></p>
<p><del>FERC VSL G3 Violation Severity Level Assignment Should Be Consistent with the Corresponding Requirement</del></p>	<p><del>The proposed VSL uses similar terminology to that used in the corresponding Requirement, and is therefore consistent with the Requirement.</del></p>
<p><del>FERC VSL G4 Violation Severity Level Assignment Should Be Based on A Single Violation, Not on A Cumulative Number of Violations</del></p>	<p><del>The VSL is based on a single violation and not cumulative violations.</del></p>

VRF and VSL Justifications—PRC-026-1-R4

Proposed VRF	High
NERC VRF Discussion	<p>A Violation Risk Factor of High is consistent with the NERC VRF Guidelines:  A failure to evaluate that the Protection System is expected to not trip for a stable power swing for an identified Element could, under emergency, abnormal, or restorative conditions anticipated by the preparations, directly cause or contribute to bulk electric system instability, separation, or a cascading sequence of failures, or could place the bulk electric system at an unacceptable risk of instability, separation, or cascading failures, or could hinder restoration to a normal condition.  If a Protection System is less secure during stable power swings, it increases the risk of tripping should the Protection System be challenged by a power swing.</p>
FERC VRF G1 Discussion	<p>Guideline 1—Consistency w/ Blackout Report:  The blackout report and subsequent technical analysis identified that two BPS transmission lines tripped due to protective relay operation in response to stable power swings. The protection system operations on these lines did not contribute significantly to the overall outcome of the August 14, 2003 system disturbance. Identifying Elements prone to power swings and the subsequent mitigation of load-responsive protective relays applied at the terminals of these Elements will reduce the likelihood of reoccurrence. This Requirement is consistent with the intent of Recommendation 8: Improve System Protection to Slow or Limit the Spread of Future Cascading Outages. While the actions associated with this recommendation did not focus specifically on this issue, the recommendation does note that “power system protection devices should be set to address the specific condition of concern, such as a fault, out-of-step condition, etc., and should not compromise a power system’s inherent physical capability to slow down or stop a cascading event.”</p>
FERC VRF G2 Discussion	<p>Guideline 2- Consistency within a Reliability Standard:  The Requirement has a single reliability activity associated with the reliability objective and no sub-Requirement(s) which allows a single VRF to be assigned; therefore no conflict(s) exist.</p>

VRF and VSL Justifications—PRC-026-1-R4

<p>FERC VRF G3 Discussion</p>	<p>Guideline 3- Consistency among Reliability Standards: The Requirement is consistent with NERC Reliability Standard PRC-023-3, R1 “...Each Transmission Owner, Generator Owner, and Distribution Provider shall evaluate relay loadability at 0.85 per unit voltage and a power factor angle of 30 degrees”) which has a VRF of High.</p>
<p>FERC VRF G4 Discussion</p>	<p>Guideline 4- Consistency with NERC Definitions of VRFs: A failure <u>of the Generator Owner or Transmission Owner</u> to <del>ensure</del><u>evaluate that</u> the Protection System <del>will</del><u>is expected to</u> not trip in response to a stable power swing <u>during a non-Fault condition</u> for <del>an</del><u>identified</u> <u>BES</u> Element could, under emergency, abnormal, or restorative conditions anticipated by the preparations, directly cause or contribute to bulk electric system instability, separation, or a cascading sequence of failures, or could place the bulk electric system at an unacceptable risk of instability, separation, or cascading failures, or could hinder restoration to a normal condition. <del>If a</del><u>A</u> Protection System <u>that does not meet the PRC-026-1 – Attachment B criteria</u> is less secure during stable power swings, it increases the risk of tripping should the Protection System be challenged by a power swing.</p>
<p>FERC VRF G5 Discussion</p>	<p>Guideline 5- Treatment of Requirements that Co-mingle More than One Obligation: This Requirement does not co-mingle reliability objectives of differing risk; therefore, the assigned VRF of Medium is consistent.</p>



VRF and VSL Justifications—PRC-026-1-R4

Proposed VSL

Lower	Moderate	High	Severe
<p>The Generator Owner <del>identified an Element and provided notification</del> <u>or Transmission Owner evaluated its load-responsive protective relay(s)</u> in accordance with Requirement <del>R3R2</del>, but was less than or equal to <del>1030</del> calendar days late.</p>	<p>The Generator Owner <del>identified an Element and provided notification</del> <u>or Transmission Owner evaluated its load-responsive protective relay(s)</u> in accordance with Requirement <del>R3R2</del>, but was more than <del>1030</del> calendar days and less than or equal to <del>2060</del> calendar days late.</p>	<p>The Generator Owner <del>identified an Element and provided notification</del> <u>or Transmission Owner evaluated its load-responsive protective relay(s)</u> in accordance with Requirement <del>R3R2</del>, but was more than <del>2060</del> calendar days and less than or equal to <del>3090</del> calendar days late.</p>	<p>The Generator Owner <del>identified an Element and provided notification</del> <u>or Transmission Owner evaluated its load-responsive protective relay(s)</u> in accordance with Requirement <del>R3R2</del>, but was more than <del>3090</del> calendar days late.</p> <p>OR</p> <p>The Generator Owner <u>or Transmission Owner</u> failed to <del>identify an Element</del> <u>evaluate its load-responsive protective relay(s)</u> in accordance with Requirement <del>R3</del>.</p> <p>OR</p> <p><del>The Generator Owner failed to provide notification in accordance with Requirement R3R2.</del></p>
<p>NERC VSL Guidelines</p>	<p>Meets NERC’s VSL Guidelines—There is an incremental aspect to the VSL for tardiness and a binary aspect for failure. The VSL is entity size-neutral because performance is driven by exception. For example, each identified Element must be evaluated.</p>		

VRF and VSL Justifications — PRC-026-1, R4

<p>FERC VSL G1 Violation Severity Level Assignments Should Not Have the Unintended Consequence of Lowering the Current Level of Compliance</p>	<p>The proposed VSL does not lower the current level of compliance because the Requirement is new.</p>
<p>FERC VSL G2 Violation Severity Level Assignments Should Ensure Uniformity and Consistency in the Determination of Penalties  Guideline 2a: The Single Violation Severity Level Assignment Category for "Binary" Requirements Is Not Consistent  Guideline 2b: Violation Severity Level Assignments that Contain Ambiguous Language</p>	<p>Guideline 2a: This Requirement is not binary; therefore, this criterion does not apply.  Guideline 2b: The proposed VSL does not use any ambiguous terminology, thereby supporting uniformity and consistency in the determination of similar penalties for similar violations.</p>
<p>FERC VSL G3 Violation Severity Level Assignment Should Be Consistent with the Corresponding Requirement</p>	<p>The proposed VSL uses similar terminology to that used in the corresponding Requirement, and is therefore consistent with the Requirement.</p>
<p>FERC VSL G4</p>	<p>The VSL is based on a single violation and not cumulative violations.</p>

VRF and VSL Justifications – PRC-026-1, R4

<p>Violation Severity Level Assignment Should Be Based on A Single Violation, Not on A Cumulative Number of Violations</p>	
----------------------------------------------------------------------------------------------------------------------------	--

VRF and VSL Justifications – PRC-004-3, R5R3

Proposed VRF	Medium
<p>NERC VRF Discussion</p>	<p>A Violation Risk Factor of Medium is consistent with the NERC VRF Guidelines:</p> <p>Failure to develop a Corrective Action Plan <del>to modify a Protection System of an identified Element that does not meet the criteria</del>(CAP) such that the Protection System of a BES Element will meet the PRC-026-1 – Attachment B criteria or to exclude the Protection System under the PRC-026-1 – Attachment A criteria (e.g., modifying the Protection System so that relay functions are supervised by power swing blocking or using relay systems that are immune to power swings) could in the planning time frame, under emergency, abnormal, or restorative conditions anticipated by the preparations, directly and adversely affect the electrical state or capability of the bulk electric system, or the ability to effectively monitor, control, or restore the bulk electric system.</p> <p>An unmitigated Protection System could affect the electrical state or capability of the bulk electric system, or the ability to effectively monitor, control, or restore the bulk electric system.</p>

VRF and VSL Justifications – PRC-004-3, ~~R5R3~~

<p>FERC VRF G1 Discussion</p>	<p>Guideline 1- Consistency w/ Blackout Report:</p> <p>The blackout report and subsequent technical analysis identified that two <u>bulk power system (BPS)</u> transmission lines tripped due to protective relay operation in response to stable power swings. -The <del>protection system</del><u>Protection System</u> operations on these lines did not contribute significantly to the overall outcome of the August 14, 2003 system disturbance; however, <del>protection system</del><u>Protection System</u> operation during stable powers swings could negatively impact system reliability under different operating conditions. <del>Identifying Elements prone</del><u>Developing a CAP such that the Protection System will meet the Attachment B criteria or to exclude the Protection System under the PRC-026-1 – Attachment A criteria (e.g., modifying the Protection System so that relay functions are supervised by power swing blocking or using relay systems that are immune to power swings and the subsequent mitigation of load-responsive protective relays)</u> applied at the terminals of <del>these</del><u>BES</u> Elements will reduce the likelihood of reoccurrence.</p> <p>This Requirement is consistent with the intent of Recommendation 8: Improve System Protection to Slow or Limit the Spread of Future Cascading Outages. -While the actions associated with this recommendation did not focus specifically on this issue <u>of Protection Systems tripping in response to stable power swings</u>, the recommendation does note that “power system protection devices should be set to address the specific condition of concern, such as a fault, out-of-step condition, etc., and should not compromise a power system’s inherent physical capability to slow down or stop a cascading event.”</p>
<p>FERC VRF G2 Discussion</p>	<p>Guideline 2- Consistency within a Reliability Standard:</p> <p>This Requirement has a single reliability activity associated with the reliability objective and no sub-Requirement(s) which allows a single VRF to be assigned; therefore no conflict(s) exist.</p>

VRF and VSL Justifications – PRC-004-3, R5R3	
FERC VRF G3 Discussion	<p>Guideline 3- Consistency among Reliability Standards:</p> <p>This Requirement is consistent with the following Reliability Standards which requiring corrective actions <del>or (e.g., Corrective Action Plans);</del> PRC-016-0.1, R2 (“...shall take corrective actions to avoid future Misoperations”), PRC-022-1, R1.5 (“For any Misoperation, a Corrective Action Plan...”), and FAC-003, R5 (“...Transmission Owner or applicable Generator Owner shall take corrective action to ensure continued vegetation management”) all three of which have a VRF of Medium.</p>
FERC VRF G4 Discussion	<p>Guideline 4- Consistency with NERC Definitions of VRFs:</p> <p>A Violation Risk Factor of Medium is consistent with the NERC VRF Guidelines:</p> <p>A failure to <del>implement</del><u>develop</u> the Corrective Action Plan <del>for a</del><u>(CAP) such that the</u> Protection System of <del>an identified</del><u>a BES Element will meet the Attachment B criteria or to exclude the Protection System under the PRC-026-1 – Attachment A criteria (e.g., modifying the Protection System so that relay functions are supervised by power swing blocking or using relay systems that are immune to power swings)</u> could in the planning time frame, under emergency, abnormal, or restorative conditions anticipated by the preparations, directly and adversely affect the electrical state or capability of the bulk electric system, or the ability to effectively monitor, control, or restore the bulk electric system.</p> <p>An unmitigated Protection System could contribute to the severity of future disturbances affecting a wider area, or potential equipment damage.</p>
FERC VRF G5 Discussion	<p>Guideline 5- Treatment of Requirements that Co-mingle More than One Obligation:</p> <p>This requirement does not co-mingle reliability objectives of differing risk; therefore, the assigned VRF of Medium is consistent.</p>

VRF and VSL Justifications – PRC-004-3, R5R3			
Proposed VSL			
Lower	Moderate	High	Severe
The Generator Owner or Transmission Owner developed a <u>Corrective Action Plan (CAP)</u> in accordance with Requirement <u>R5R3</u> , but in more than <del>60</del> <u>six</u> calendar <del>days</del> <u>months</u> and less than or equal to <del>70</del> <u>seven</u> calendar <del>days</del> <u>months</u> .	The Generator Owner or Transmission Owner developed a <u>Corrective Action Plan (CAP)</u> in accordance with Requirement <u>R5R3</u> , but in more than <del>70</del> <u>seven</u> calendar <del>days</del> <u>months</u> and less than or equal to <del>80</del> <u>eight</u> calendar <del>days</del> <u>months</u> .	The Generator Owner or Transmission Owner developed a <u>Corrective Action Plan (CAP)</u> in accordance with Requirement <u>R5R3</u> , but in more than <del>80</del> <u>eight</u> calendar <del>days</del> <u>months</u> and less than or equal to <del>90</del> <u>nine</u> calendar <del>days</del> <u>months</u> .	The Generator Owner or Transmission Owner developed a <u>Corrective Action Plan (CAP)</u> in accordance with Requirement <u>R5R3</u> , but in more than <del>90</del> <u>nine</u> calendar <del>days</del> <u>months</u> .  OR The Generator Owner or Transmission Owner failed to develop a CAP in accordance with Requirement <u>R5R3</u> .
NERC VSL Guidelines	Meets NERC’s VSL Guidelines—There is an incremental aspect to the VSL for failing to develop the Corrective Action Plan in a timely fashion and a binary aspect for a complete failure. The VSL is entity size-neutral because performance is driven by the need to mitigate the Protection System so that it is expected to not trip on a stable power swing.		
FERC VSL G1 Violation Severity Level Assignments Should Not Have the Unintended Consequence of Lowering the Current Level of Compliance	The proposed VSL does not lower the current level of compliance because the Requirement is new.		

VRF and VSL Justifications – PRC-004-3, ~~R5R3~~

<p>FERC VSL G2</p> <p>Violation Severity Level Assignments Should Ensure Uniformity and Consistency in the Determination of Penalties</p> <p>Guideline 2a: The Single Violation Severity Level Assignment Category for "Binary" Requirements Is Not Consistent</p> <p>Guideline 2b: Violation Severity Level Assignments that Contain Ambiguous Language</p>	<p>Guideline 2a:</p> <p>This Requirement is not binary; therefore, this criterion does not apply.</p> <p>Guideline 2b:</p> <p>This proposed VSL does not use any ambiguous terminology, thereby supporting uniformity and consistency in the determination of similar penalties for similar violations.</p>
<p>FERC VSL G3</p> <p>Violation Severity Level Assignment Should Be Consistent with the Corresponding Requirement</p>	<p>This proposed VSL uses similar terminology to that used in the corresponding Requirement, and is therefore consistent with this Requirement.</p>
<p>FERC VSL G4</p> <p>Violation Severity Level Assignment Should Be Based on A Single Violation, Not on A Cumulative Number of Violations</p>	<p>The VSL is based on a single violation and not cumulative violations.</p>

VRF and VSL Justifications – PRC-026-1, R4R4	
Proposed VRF	Medium
NERC VRF Discussion	<p>A Violation Risk Factor of Medium is consistent with the NERC VRF Guidelines:</p> <p>A failure to implement the Corrective Action Plan <del>for modifying a Protection System of an identified Element</del>(CAP) <u>to meet the PRC-026-1 – Attachment B criteria or to exclude the Protection System under the PRC-026-1 – Attachment A criteria (e.g., modifying the Protection System so that relay functions are supervised by power swing blocking or using relay systems that are immune to power swings)</u> could in the planning time frame, under emergency, abnormal, or restorative conditions anticipated by the preparations, directly and adversely affect the electrical state or capability of the bulk electric system, or the ability to effectively monitor, control, or restore the bulk electric system.</p> <p>An unmitigated Protection System could affect the electrical state or capability of the bulk electric system, or the ability to effectively monitor, control, or restore the bulk electric system.</p>
FERC VRF G1 Discussion	<p>Guideline 1- Consistency w/ Blackout Report:</p> <p>The blackout report and subsequent technical analysis identified that two <u>bulk power system (BPS)</u> transmission lines tripped due to protective relay operation in response to stable power swings. -The <del>protection system</del><u>Protection System</u> operations on these lines did not contribute significantly to the overall outcome of the August 14, 2003 system disturbance; however, <del>protection system</del><u>Protection System</u> operation during stable powers swings could negatively impact system reliability under different operating conditions. <del>Identifying Elements prone</del><u>Implementing a CAP such that the Protection System will meet the Attachment B criteria or to exclude the Protection System under the PRC-026-1 – Attachment A criteria (e.g., modifying the Protection System so that relay functions are supervised by power swing blocking or using relay systems that are immune</u> to power swings <del>and the subsequent mitigation of load-responsive protective relays)</del> applied at the terminals of these Elements will reduce the likelihood of reoccurrence.</p>



VRF and VSL Justifications – PRC-026-1, <del>R6R4</del>	
	<p>This Requirement is consistent with the intent of Recommendation 8: Improve System Protection to Slow or Limit the Spread of Future Cascading Outages. -While the actions associated with this recommendation did not focus specifically on this issue <u>of Protection Systems tripping in response to stable power swings</u>, the recommendation does note that “power system protection devices should be set to address the specific condition of concern, such as a fault, out-of-step condition, etc., and should not compromise a power system’s inherent physical capability to slow down or stop a cascading event.”</p>
FERC VRF G2 Discussion	<p>Guideline 2- Consistency within a Reliability Standard:</p> <p>The Requirement has a single reliability activity associated with the reliability objective and no sub-Requirement(s) which allows a single VRF to be assigned; therefore no conflict(s) exist.</p>
FERC VRF G3 Discussion	<p>Guideline 3- Consistency among Reliability Standards:</p> <p>This Requirement is consistent with the following Reliability Standards which requiring corrective actions <del>or (e.g., Corrective Action Plans-):</del> PRC-016-0.1, R2 (“...shall take corrective actions to avoid future Misoperations”), PRC-022-1, R1.5 (“For any Misoperation, a Corrective Action Plan...”), and FAC-003, R5 (“...Transmission Owner or applicable Generator Owner shall take corrective action to ensure continued vegetation management”) all of which have a VRF of Medium.</p>
FERC VRF G4 Discussion	<p>A Violation Risk Factor of Medium is consistent with the NERC VRF Guidelines:</p> <p>A failure to implement the Corrective Action Plan <del>for a Protection System of an identified Element</del> <u>such that the Protection System of a BES Element will meet the Attachment B criteria or to exclude the Protection System under the PRC-026-1 – Attachment A criteria (e.g., modifying the Protection System so that relay functions are supervised by power swing blocking or using relay systems that are immune to power swings)</u> could in the planning time frame, under emergency, abnormal, or restorative conditions anticipated by the preparations, directly and adversely affect the electrical state or capability of the bulk electric system, or the ability to effectively monitor, control, or restore the bulk electric system.</p> <p>An unmitigated Protection System could contribute to the severity of future disturbances affecting a wider area, or potential equipment damage.</p>

VRF and VSL Justifications – PRC-026-1, <del>R6R4</del>			
FERC VRF G5 Discussion	<p>Guideline 5- Treatment of Requirements that Co-mingle More than One Obligation:</p> <p>This Requirement does not co-mingle reliability objectives of differing risk; therefore, the assigned VRF of Medium is consistent.</p>		
Proposed VSL			
Lower	Moderate	High	Severe
The responsible entity implemented, but failed to update a CAP, when actions or timetables changed, in accordance with Requirement R4.	N/A	N/A	The responsible entity failed to implement a CAP in accordance with Requirement R4.
NERC VSL Guidelines	<p>Meets NERC’s VSL Guidelines—There is an incremental aspect to the VSL for failing to update the Corrective Action Plan and a binary aspect for failure to implement. The VSL is entity size-neutral because performance is driven by the need to mitigate the Protection System so that it is expected to not trip on a stable power swing.</p>		
FERC VSL G1 Violation Severity Level Assignments Should Not Have the Unintended Consequence of Lowering the Current Level of Compliance	<p>The proposed VSL does not lower the current level of compliance because the Requirement is new.</p>		

VRF and VSL Justifications – PRC-026-1, ~~R6R4~~

<p>FERC VSL G2</p> <p>Violation Severity Level Assignments Should Ensure Uniformity and Consistency in the Determination of Penalties</p> <p>Guideline 2a: The Single Violation Severity Level Assignment Category for "Binary" Requirements Is Not Consistent</p> <p>Guideline 2b: Violation Severity Level Assignments that Contain Ambiguous Language</p>	<p>Guideline 2a:</p> <p>This Requirement is not binary; therefore, this criterion does not apply.</p> <p>Guideline 2b:</p> <p>The proposed VSL does not use any ambiguous terminology, thereby supporting uniformity and consistency in the determination of similar penalties for similar violations.</p>
<p>FERC VSL G3</p> <p>Violation Severity Level Assignment Should Be Consistent with the Corresponding Requirement</p>	<p>The proposed VSL uses similar terminology to that used in the corresponding Requirement, and is therefore consistent with the Requirement.</p>
<p>FERC VSL G4</p> <p>Violation Severity Level Assignment Should Be Based on A Single Violation, Not on A Cumulative Number of Violations</p>	<p>The VSL is based on a single violation and not cumulative violations.</p>

## Table of Issues and Directives

### Project 2010-13.3 – Relay Loadability: Stable Power Swings

Table of Issues and Directives Associated with PRC-026-1

Source	Issue or Directive Language (including Para. #)	Section and/or Requirement(s)	Consideration of Issue or Directive
FERC Order 733	<b>150.</b> We will not direct the ERO to modify PRC-023-1 to address stable power swings. However, because both NERC and the Task Force have identified undesirable relay operation due to stable power swings as a reliability issue, we direct the ERO to develop a Reliability Standard that requires the use of protective relay systems that can differentiate between faults and stable power swings and, when necessary, phases out protective relay systems that cannot meet this requirement.	All requirements	The PRC-026-1 standard is responsive to this directive by using an equally effective and efficient focused approach for the Planning Coordinator to provide notification of BES Elements according to the Requirement R1 criteria to the respective Generator Owner and Transmission Owner. The criteria used to identify a BES Element are based on the NERC System Protection and Control Subcommittee technical document, <i>Protection System Response to Power Swings</i> (“PSRPS Report”). <sup>1</sup> The specific criteria are based on where power swings are expected to challenge load-responsive protective relays.  The criteria include 1) Generator(s) where an angular stability constraint exists that is addressed by a

<sup>1</sup> NERC System Protection and Control Subcommittee technical document, *Protection System Response to Power Swings*, August 2013: [http://www.nerc.com/comm/PC/System%20Protection%20and%20Control%20Subcommittee%20SPCS%2020/SPCS%20Power%20Swing%20Report\\_Final\\_20131015.pdf](http://www.nerc.com/comm/PC/System%20Protection%20and%20Control%20Subcommittee%20SPCS%2020/SPCS%20Power%20Swing%20Report_Final_20131015.pdf)

Table of Issues and Directives Associated with PRC-026-1

Source	Issue or Directive Language (including Para. #)	Section and/or Requirement(s)	Consideration of Issue or Directive
	<p>We also direct the ERO to file a report no later than 120 days of this Final Rule addressing the issue of protective relay operation due to power swings. The report should include an action plan and timeline that explains how and when the ERO intends to address this issue through its Reliability Standards development process.</p> <p><b>AND</b></p> <p><b>153.</b> While we recognize that addressing stable power swings is a complex issue, we note that more than six years have passed since the August 2003 blackout and there is still no Reliability Standard that addresses relays tripping due to stable power swings. Additionally, NERC has long identified undesirable relay operation due to stable power swings as a reliability issue. Consequently, pursuant to section 215(d)(5) of the FPA, we find</p>		<p>System Operating Limit (SOL) or a Remedial Action Scheme (RAS) and those Elements terminating at the Transmission station associated with the generator(s); 2) An Element that is monitored as part of a SOL identified by the Planning Coordinator’s methodology based on an angular stability constraint; 3) An Element that forms the boundary of an island in the most recent underfrequency load shedding (UFLS) design assessment based on application of the Planning Coordinator’s criteria for identifying islands, where the island is formed by tripping the Element based on angular instability; 4) An Element identified in the most recent annual Planning Assessment where relay tripping occurs due to a stable or unstable power swing during a simulated disturbance.</p> <p>Requirement R2 requires the Generator Owner and Transmission Owner to evaluate its load-responsive protective relays that are applied at all of the terminals of each BES Element identified by the Planning Coordinator in Requirement R1 or upon becoming aware of a generator, transformer, or</p>

Table of Issues and Directives Associated with PRC-026-1

Source	Issue or Directive Language (including Para. #)	Section and/or Requirement(s)	Consideration of Issue or Directive
	<p>that undesirable relay operation due to stable power swings is a specific matter that the ERO must address to carry out the goals of section 215, and we direct the ERO to develop a Reliability Standard addressing undesirable relay operation due to stable power swings.</p>		<p>transmission line BES Element that tripped in response to a stable or unstable power swing due to the operation of its protective relay(s). The initial evaluation allows the Generator Owner and Transmission Owner to determine whether its load-responsive protective relays applied at all of the terminals of the BES Element meet the PRC-026-1 – Attachment B criteria. Additionally, the Requirement ensures that the Generator Owner and Transmission Owner must re-evaluate the Protection System on a five year basis should the BES Element continue to be identified by the Planning Coordinator in Requirement R1.</p> <p>Requirement R3 mandates the development of a Corrective Action Plan (CAP) such that the Protection System of a BES Element will meet the PRC-026-1 – Attachment B criteria or to exclude the Protection System under the PRC-026-1 – Attachment A criteria (e.g., modifying the Protection System so that relay functions are supervised by power swing blocking or using relay systems that are immune to power swings).</p>

Table of Issues and Directives Associated with PRC-026-1

Source	Issue or Directive Language (including Para. #)	Section and/or Requirement(s)	Consideration of Issue or Directive
			Requirement R4 mandates that the Generator Owner and Transmission Owner implement each developed CAP in Requirement R3 so that load-responsive protective relays are expected to not trip in response to stable power swings during non-Fault conditions.
	<p><b>162.</b> The PSEG Companies also assert that the Commission’s approach to stable power swings should be inclusive and include “islanding” strategies in conjunction with out-of-step blocking or tripping requirements. We agree with the PSEG Companies and direct the ERO to consider “islanding” strategies that achieve the fundamental performance for all islands in developing the new Reliability Standard addressing stable power swings.</p>	Requirement R1, Criterion 3 and Requirement R2, Criterion 2.	<p>Islanding strategies were considered during the development of the proposed standard. It was determined that consideration of islanding strategies does not comport with the purpose and approach of the proposed standard. Islanding strategies are developed to isolate the system from unstable power swings, which is not prohibited under the proposed standard. The proposed standard’s purpose is to ensure that load-responsive protective relays are expected to not trip in response to stable power swings during non-Fault conditions, not to determine where the BES Elements should form island boundaries.</p> <p>With respect to considering the islanding concern, the proposed standard does require that a BES</p>

Table of Issues and Directives Associated with PRC-026-1

Source	Issue or Directive Language (including Para. #)	Section and/or Requirement(s)	Consideration of Issue or Directive
			<p>Element that forms the boundary of an island in the most recent underfrequency load shedding (UFLS) design assessment based on application of the Planning Coordinator’s criteria for identifying islands, where the island is formed by tripping the Element based on angular instability.</p> <p>Any identified BES Element(s) require the Generator Owner and Transmission Owner to determine whether its load-responsive protective relays, if any, applied at the terminals of such an Element are susceptible to tripping in response to a stable power swing. If so, the Generator Owner and Transmission Owner are required to take specific action according to the Requirements to reduce the risk that any load-responsive protective relay would trip in response to stable power swings during non-Fault conditions.</p>



## Standards Announcement **Reminder**

### Project 2010-13.3 – Phase 3 of Relay Loadability: Stable Power Swings PRC-026-1

**Additional Ballot and Non-Binding Poll Now Open through November 24, 2014**

#### [Now Available](#)

An additional ballot for **PRC-026-1 - Relay Performance During Stable Power Swing** and a non-binding poll of the associated Violation Risk Factors (VRFs) and Violation Severity Levels (VSLs) is open through **8 p.m. Eastern, Monday, November 24, 2014**.

#### **Instructions for Balloting**

Members of the ballot pools associated with this project may log in and submit their vote for the standard and associated VRFs and VSLs by clicking [here](#).

**Note:** If a member cast a vote in the initial ballot, that vote will not carry over to the additional ballot. It is the responsibility of the registered voter in the ballot pool to cast a vote again in the additional ballot. To ensure a quorum is reached, if you do not want to vote affirmative or negative, please cast an abstention.

#### **Next Steps**

The ballot results will be announced and posted on the project page. The drafting team will consider all comments received during the formal comment period and, if needed, make revisions to the standard and post it for an additional ballot. If the comments do not show the need for significant revisions, the standard will proceed to a final ballot.

For information on the **Standards Development Process**, please refer to the [Standard Processes Manual](#).

*For more information or assistance, please contact Standards Developer, [Scott Barfield](#), or by telephone at 404-446-9689.*

North American Electric Reliability Corporation  
3353 Peachtree Rd, NE  
Suite 600, North Tower  
Atlanta, GA 30326  
404-446-2560 | [www.nerc.com](http://www.nerc.com)

# Standards Announcement

## Project 2010-13.3 – Phase 3 of Relay Loadability: Stable Power Swings PRC-026-1

Formal Comment Period Now Open through November 24, 2014

### [Now Available](#)

A 21-day formal comment period for **PRC-026-1 - Relay Performance During Stable Power Swings** is open through **8 p.m. Eastern, Monday, November 24, 2014**.

The Standards Committee (SC) authorized a waiver to shorten the comment period for PRC-026-1 from 45 days to 21 days, with an additional ballot and non-binding poll to be conducted during the last 10 days of the comment period. The notice of waiver request presented to the SC for consideration is posted on the [project page](#).

### Instructions for Commenting

Please use the [electronic form](#) to submit comments. If you experience any difficulties in using the electronic form, please contact [Arielle Cunningham](#). An off-line, unofficial copy of the comment form is posted on the [project page](#).

### Next Steps

An additional ballot for the standard and non-binding poll of the associated Violation Risk Factors and Violation Severity Levels will be conducted **November 14-24, 2014**.

**Note:** If a member cast a vote in the initial ballot, that vote **will not** carry over to the additional ballot. It is the responsibility of the registered voter in the ballot pool to cast a vote again in the additional ballot. To ensure a quorum is reached, please cast an abstention if you do not want to vote affirmative or negative.

For information on the **Standards Development Process**, please refer to the [Standard Processes Manual](#).

*For more information or assistance, please contact [Scott Barfield](#),  
Standards Developer, or via telephone at 404-446-9689.*

North American Electric Reliability Corporation  
3353 Peachtree Rd, NE  
Suite 600, North Tower  
Atlanta, GA 30326  
404-446-2560 | [www.nerc.com](http://www.nerc.com)

# Standards Announcement

## Project 2010-13.3 – Phase 3 of Relay Loadability: Stable Power Swings PRC-026-1

Formal Comment Period Now Open through November 24, 2014

### [Now Available](#)

A 21-day formal comment period for **PRC-026-1 - Relay Performance During Stable Power Swings** is open through **8 p.m. Eastern, Monday, November 24, 2014**.

The Standards Committee (SC) authorized a waiver to shorten the comment period for PRC-026-1 from 45 days to 21 days, with an additional ballot and non-binding poll to be conducted during the last 10 days of the comment period. The notice of waiver request presented to the SC for consideration is posted on the [project page](#).

### Instructions for Commenting

Please use the [electronic form](#) to submit comments. If you experience any difficulties in using the electronic form, please contact [Arielle Cunningham](#). An off-line, unofficial copy of the comment form is posted on the [project page](#).

### Next Steps

An additional ballot for the standard and non-binding poll of the associated Violation Risk Factors and Violation Severity Levels will be conducted **November 14-24, 2014**.

**Note:** If a member cast a vote in the initial ballot, that vote **will not** carry over to the additional ballot. It is the responsibility of the registered voter in the ballot pool to cast a vote again in the additional ballot. To ensure a quorum is reached, please cast an abstention if you do not want to vote affirmative or negative.

For information on the **Standards Development Process**, please refer to the [Standard Processes Manual](#).

*For more information or assistance, please contact [Scott Barfield](#),  
Standards Developer, or via telephone at 404-446-9689.*

North American Electric Reliability Corporation  
3353 Peachtree Rd, NE  
Suite 600, North Tower  
Atlanta, GA 30326  
404-446-2560 | [www.nerc.com](http://www.nerc.com)

# Standards Announcement

## Project 2010-13.3 Phase 3 of Relay Loadability: Stable Power Swings PRC-026-1

### Additional Ballot and Non-Binding Poll Results

#### [Now Available](#)

An additional ballot for **PRC-026-1 – Relay Performance During Stable Power Swings** and a non-binding poll of the associated Violation Risk Factors and Violation Severity Levels concluded at **8 p.m. Eastern on Monday, November 24, 2014**.

The standard achieved a quorum and received sufficient affirmative votes for approval. Voting statistics are listed below, and the [Ballot Results](#) page provides a link to the detailed results for the ballot.

Ballot	Non-Binding Poll
Quorum /Approval	Quorum/Supportive Opinions
79.83% / 67.39%	78.61% / 66.13%

Background information for this project can be found on the [project page](#).

#### Next Steps

The drafting team will consider all comments received during the formal comment period and, if needed, make revisions to the standard and post it for an additional ballot. If the comments do not show the need for significant revisions, the standard will proceed to a final ballot.

For more information on the **Standards Development Process**, please refer to the [Standard Processes Manual](#).

*For more information or assistance, please contact Standards Developer, [Scott Barfield](#), or by telephone at 404-446-9689.*

North American Electric Reliability Corporation  
3353 Peachtree Rd, NE  
Suite 600, North Tower  
Atlanta, GA 30326  
404-446-2560 | [www.nerc.com](http://www.nerc.com)

Log In

- Ballot Pools
- Current Ballots
- Ballot Results
- Registered Ballot Body
- Proxy Voters
- Register

[Home Page](#)

Ballot Results	
<b>Ballot Name:</b>	Project 2010-13.3 Relay Loadability Stable Power Swings PRC-026-1
<b>Ballot Period:</b>	11/14/2014 - 11/24/2014
<b>Ballot Type:</b>	Additional
<b>Total # Votes:</b>	289
<b>Total Ballot Pool:</b>	362
<b>Quorum:</b>	<b>79.83 % The Quorum has been reached</b>
<b>Weighted Segment Vote:</b>	67.39 %
<b>Ballot Results:</b>	<b>The Ballot has Closed</b>

Summary of Ballot Results										
Segment	Ballot Pool	Segment Weight	Affirmative		Negative		Negative Vote without a Comment	Abstain	No Vote	
			# Votes	Fraction	# Votes	Fraction				
1 - Segment 1	104	1	38	0.594	26	0.406	1	16	23	
2 - Segment 2	9	0.8	6	0.6	2	0.2	0	0	1	
3 - Segment 3	76	1	34	0.68	16	0.32	0	11	15	
4 - Segment 4	25	1	10	0.556	8	0.444	0	4	3	
5 - Segment 5	79	1	33	0.611	21	0.389	0	8	17	
6 - Segment 6	52	1	22	0.611	14	0.389	0	5	11	
7 - Segment 7	2	0.1	0	0	1	0.1	0	0	1	
8 - Segment 8	4	0.4	3	0.3	1	0.1	0	0	0	
9 - Segment	2	0.2	2	0.2	0	0	0	0	0	

9										
10 - Segment 10	9	0.7	7	0.7	0	0	0	0	0	2
<b>Totals</b>	<b>362</b>	<b>7.2</b>	<b>155</b>	<b>4.852</b>	<b>89</b>	<b>2.348</b>	<b>1</b>	<b>44</b>	<b>73</b>	

Individual Ballot Pool Results				
Segment	Organization	Member	Ballot	NERC Notes
1	Ameren Services	Eric Scott	Affirmative	
1	American Electric Power	Paul B Johnson	Affirmative	
1	American Transmission Company, LLC	Andrew Z Puszta	Affirmative	
1	Arizona Public Service Co.	Robert Smith		
1	Associated Electric Cooperative, Inc.	John Bussman	Negative	SUPPORTS THIRD PARTY COMMENTS - (AECI)
1	ATCO Electric	Glen Sutton	Abstain	
1	Austin Energy	James Armke	Abstain	
1	Avista Utilities	Heather Rosentrater		
1	Balancing Authority of Northern California	Kevin Smith	Affirmative	
1	Baltimore Gas & Electric Company	Christopher J Scanlon	Affirmative	
1	BC Hydro and Power Authority	Patricia Robertson	Negative	COMMENT RECEIVED
1	Black Hills Corp	Wes Wingen	Abstain	
1	Brazos Electric Power Cooperative, Inc.	Tony Kroskey		
1	Bryan Texas Utilities	John C Fontenot	Negative	SUPPORTS THIRD PARTY COMMENTS - (Luminant)
1	CenterPoint Energy Houston Electric, LLC	John Brockhan	Negative	COMMENT RECEIVED
1	Central Electric Power Cooperative	Michael B Bax	Negative	SUPPORTS THIRD PARTY COMMENTS - (AECI)
1	Central Iowa Power Cooperative	Kevin J Lyons	Affirmative	
1	City of Tacoma, Department of Public Utilities, Light Division, dba Tacoma Power	Chang G Choi	Affirmative	
1	City of Tallahassee	Daniel S Langston	Abstain	
1	Clark Public Utilities	Jack Stamper	Affirmative	
1	Colorado Springs Utilities	Shawna Speer	Negative	SUPPORTS THIRD PARTY COMMENTS - (PSEG) - (Colorado Springs Utilities)
1	Consolidated Edison Co. of New York	Christopher L de Graffenried	Affirmative	
1	CPS Energy	Glenn Pressler	Negative	SUPPORTS THIRD PARTY COMMENTS - (Luminant)
1	Dairyland Power Coop.	Robert W. Roddy	Negative	SUPPORTS THIRD PARTY COMMENTS - (NSRF)
1	Deseret Power	James Tucker	Abstain	
1	Dominion Virginia Power	Larry Nash	Affirmative	
1	Duke Energy Carolina	Doug E Hills	Negative	SUPPORTS THIRD PARTY COMMENTS - (Duke Energy)
1	Empire District Electric Co.	Ralph F Meyer	Abstain	
1	Encari	Steven E Hamburg		
1	Entergy Transmission	Oliver A Burke	Negative	COMMENT RECEIVED
1	FirstEnergy Corp.	William J Smith	Affirmative	
1	Florida Keys Electric Cooperative Assoc.	Dennis Minton		
1	Florida Power & Light Co.	Mike O'Neil	Affirmative	

1	Gainesville Regional Utilities	Richard Bachmeier		
1	Georgia Transmission Corporation	Jason Snodgrass	Affirmative	
1	Great River Energy	Gordon Pietsch	Affirmative	
1	Hydro One Networks, Inc.	Muhammed Ali	Affirmative	
1	Hydro-Quebec TransEnergie	Martin Boisvert	Affirmative	
1	Idaho Power Company	Molly Devine	Affirmative	
1	International Transmission Company Holdings Corp	Michael Moltane	Negative	COMMENT RECEIVED
1	JDRJC Associates	Jim D Cyrulewski	Abstain	
1	JEA	Ted E Hobson	Negative	COMMENT RECEIVED
1	KAMO Electric Cooperative	Walter Kenyon	Negative	SUPPORTS THIRD PARTY COMMENTS - (AECI)
1	Kansas City Power & Light Co.	Daniel Gibson	Negative	COMMENT RECEIVED
1	Keys Energy Services	Stan T Rzad	Negative	NO COMMENT RECEIVED
1	Lakeland Electric	Larry E Watt		
1	Lee County Electric Cooperative	John Chin		
1	Los Angeles Department of Water & Power	faranak sarbaz	Abstain	
1	Lower Colorado River Authority	Martyn Turner	Affirmative	
1	Manitoba Hydro	Jo-Anne M Ross	Affirmative	
1	MEAG Power	Danny Dees	Affirmative	
1	MidAmerican Energy Co.	Terry Harbour	Negative	SUPPORTS THIRD PARTY COMMENTS - (MRO NSRF)
1	Minnkota Power Coop. Inc.	Daniel L Inman	Negative	SUPPORTS THIRD PARTY COMMENTS - (See NSRF's Comments)
1	N.W. Electric Power Cooperative, Inc.	Mark Ramsey	Negative	SUPPORTS THIRD PARTY COMMENTS - (AECI)
1	National Grid USA	Michael Jones	Affirmative	
1	NB Power Corporation	Alan MacNaughton	Abstain	
1	Nebraska Public Power District	Jamison Cawley	Negative	COMMENT RECEIVED
1	New York Power Authority	Bruce Metruck	Affirmative	
1	Northeast Missouri Electric Power Cooperative	Kevin White	Negative	SUPPORTS THIRD PARTY COMMENTS - (AECI)
1	Northeast Utilities	William Temple	Affirmative	
1	Northern Indiana Public Service Co.	Julaine Dyke	Abstain	
1	NorthWestern Energy	John Canavan		
1	Ohio Valley Electric Corp.	Scott R Cunningham	Affirmative	
1	Oklahoma Gas and Electric Co.	Terri Pyle		
1	Omaha Public Power District	Doug Peterchuck	Negative	SUPPORTS THIRD PARTY COMMENTS - (MRO NSRF)
1	Oncor Electric Delivery	Jen Fiegel	Affirmative	
1	Otter Tail Power Company	Daryl Hanson	Negative	SUPPORTS THIRD PARTY COMMENTS - (MRO NSRF)
1	Pacific Gas and Electric Company	Bangalore Vijayraghavan		
1	Peak Reliability	Jared Shakespeare		
1	Platte River Power Authority	John C. Collins	Affirmative	
1	Portland General Electric Co.	John T Walker	Affirmative	
1	Potomac Electric Power Co.	David Thorne	Abstain	
1	PPL Electric Utilities Corp.	Brenda L Truhe	Negative	SUPPORTS THIRD PARTY COMMENTS - (Refer to comments submitted on behalf of PPL)

				NERC Registered Affiliates)
1	Public Service Company of New Mexico	Laurie Williams		
1	Public Service Electric and Gas Co.	Kenneth D. Brown	Negative	COMMENT RECEIVED
1	Public Utility District No. 1 of Okanogan County	Dale Dunckel	Abstain	
1	Puget Sound Energy, Inc.	Denise M Lietz	Affirmative	
1	Rochester Gas and Electric Corp.	John C. Allen	Abstain	
1	Sacramento Municipal Utility District	Tim Kelley	Affirmative	
1	Salt River Project	Robert Kondziolka	Affirmative	
1	SaskPower	Wayne Guttormson	Abstain	
1	Seattle City Light	Pawel Krupa	Negative	SUPPORTS THIRD PARTY COMMENTS - (Seattle City Light Paul Haase's comment)
1	Seminole Electric Cooperative, Inc.	Glenn Spurlock	Negative	SUPPORTS THIRD PARTY COMMENTS - (Seminole Electric Cooperative Comments submitted by Maryclaire Yatsko)
1	Sho-Me Power Electric Cooperative	Denise Stevens		
1	Snohomish County PUD No. 1	Long T Duong	Affirmative	
1	South Carolina Electric & Gas Co.	Tom Hanzlik	Affirmative	
1	South Carolina Public Service Authority	Shawn T Abrams	Abstain	
1	Southern California Edison Company	Steven Mavis	Affirmative	
1	Southern Company Services, Inc.	Robert A. Schaffeld	Affirmative	
1	Southern Illinois Power Coop.	William Hutchison		
1	Southwest Transmission Cooperative, Inc.	John Shaver	Affirmative	
1	Sunflower Electric Power Corporation	Noman Lee Williams		
1	Tampa Electric Co.	Beth Young		
1	Tennessee Valley Authority	Howell D Scott	Abstain	
1	Trans Bay Cable LLC	Steven Powell	Affirmative	
1	Tri-State Generation & Transmission Association, Inc.	Tracy Sliman	Affirmative	
1	Tucson Electric Power Co.	John Tolo		
1	U.S. Bureau of Reclamation	Richard T Jackson		
1	United Illuminating Co.	Jonathan Appelbaum	Affirmative	
1	Vermont Electric Power Company, Inc.	Kim Moulton		
1	Westar Energy	Allen Klassen	Negative	SUPPORTS THIRD PARTY COMMENTS - (SPP Standards Group)
1	Western Area Power Administration	Lloyd A Linke		
1	Wolverine Power Supply Coop., Inc.	Michelle Clements		
1	Xcel Energy, Inc.	Gregory L Pieper		
2	BC Hydro	Venkataramakrishnan Vinnakota	Negative	SUPPORTS THIRD PARTY COMMENTS - (Patria Robertson)
2	California ISO	Rich Vine	Negative	COMMENT RECEIVED
2	Electric Reliability Council of Texas, Inc.	Cheryl Moseley	Affirmative	
2	Independent Electricity System Operator	Leonard Kula	Affirmative	
2	ISO New England, Inc.	Matthew F Goldberg	Affirmative	
2	MISO	Marie Knox	Affirmative	
2	New York Independent System Operator	Gregory Campoli		
2	PJM Interconnection, L.L.C.	stephanie monzon	Affirmative	
2	Southwest Power Pool, Inc.	Charles H. Yeung	Affirmative	
3	AEP	Michael E Deloach	Affirmative	
3	Alabama Power Company	Robert S Moore	Affirmative	



3	Ameren Corp.	David J Jendras	Affirmative	
3	APS	Sarah Kist		
3	Associated Electric Cooperative, Inc.	Todd Bennett	Negative	SUPPORTS THIRD PARTY COMMENTS - (AECI)
3	Atlantic City Electric Company	NICOLE BUCKMAN		
3	Avista Corp.	Scott J Kinney	Abstain	
3	BC Hydro and Power Authority	Pat G. Harrington	Negative	SUPPORTS THIRD PARTY COMMENTS - (BC Hydro)
3	Central Electric Power Cooperative	Adam M Weber		
3	City of Austin dba Austin Energy	Andrew Gallo	Abstain	
3	City of Clewiston	Lynne Mila	Affirmative	
3	City of Farmington	Linda R Jacobson	Abstain	
3	City of Green Cove Springs	Mark Schultz	Affirmative	
3	City of Redding	Bill Hughes	Affirmative	
3	City of Tallahassee	Bill R Fowler	Abstain	
3	Colorado Springs Utilities	Jean Mueller	Negative	SUPPORTS THIRD PARTY COMMENTS - (PSEG) - (Kaleb Brimhall)
3	ComEd	John Bee	Affirmative	
3	Consolidated Edison Co. of New York	Peter T Yost	Affirmative	
3	Consumers Energy Company	Gerald G Farringer	Affirmative	
3	Cowlitz County PUD	Russell A Noble		
3	CPS Energy	Jose Escamilla		
3	Delmarva Power & Light Co.	Michael R. Mayer		
3	Dominion Resources, Inc.	Connie B Lowe	Affirmative	
3	DTE Electric	Kent Kujala	Negative	COMMENT RECEIVED
3	FirstEnergy Corp.	Cindy E Stewart	Affirmative	
3	Florida Keys Electric Cooperative	Tom B Anthony	Abstain	
3	Florida Municipal Power Agency	Joe McKinney	Affirmative	
3	Florida Power & Light Co.	Summer C. Esquerre	Affirmative	
3	Florida Power Corporation	Lee Schuster	Negative	SUPPORTS THIRD PARTY COMMENTS - (Duke Energy)
3	Georgia System Operations Corporation	Scott McGough		
3	Great River Energy	Brian Glover	Affirmative	
3	Hydro One Networks, Inc.	Ayesha Sabouba	Affirmative	
3	JEA	Garry Baker		
3	Kansas City Power & Light Co.	Joshua D Bach	Negative	COMMENT RECEIVED
3	Lakeland Electric	Mace D Hunter		
3	Lee County Electric Cooperative	David A Hadzima		
3	Lincoln Electric System	Jason Fortik	Negative	SUPPORTS THIRD PARTY COMMENTS - (MRO NSRF)
3	Los Angeles Department of Water & Power	Mike Ancil	Abstain	
3	Louisville Gas and Electric Co.	Charles A. Freibert	Negative	SUPPORTS THIRD PARTY COMMENTS - (PPL NERC Registered Affiliates)
3	Manitoba Hydro	Greg C. Parent	Affirmative	
3	MEAG Power	Roger Brand	Affirmative	
3	MidAmerican Energy Co.	Thomas C. Mielnik	Negative	SUPPORTS THIRD PARTY COMMENTS - (MRO NSRF Comments)
3	Modesto Irrigation District	Jack W Savage	Affirmative	
3	Muscatine Power & Water	John S Bos		
3	National Grid USA	Brian E Shanahan	Affirmative	
				SUPPORTS THIRD PARTY

3	Nebraska Public Power District	Tony Eddleman	Negative	COMMENTS - (Nebraska Public Power District comments.)
3	New York Power Authority	David R Rivera	Affirmative	
3	Northern Indiana Public Service Co.	Ramon J Barany	Abstain	
3	NW Electric Power Cooperative, Inc.	David McDowell		
3	Ocala Utility Services	Randy Hahn	Affirmative	
3	Oklahoma Gas and Electric Co.	Donald Hargrove		
3	Omaha Public Power District	Blaine R. Dinwiddie	Negative	SUPPORTS THIRD PARTY COMMENTS - (MRO NSRF comments)
3	Orlando Utilities Commission	Ballard K Mutters	Affirmative	
3	Owensboro Municipal Utilities	Thomas T Lyons	Affirmative	
3	Pacific Gas and Electric Company	John H Hagen	Affirmative	
3	Platte River Power Authority	Terry L Baker	Affirmative	
3	PNM Resources	Michael Mertz	Abstain	
3	Portland General Electric Co.	Thomas G Ward	Affirmative	
3	Potomac Electric Power Co.	Mark Yerger	Abstain	
3	Public Service Electric and Gas Co.	Jeffrey Mueller	Negative	SUPPORTS THIRD PARTY COMMENTS - (Public Service Enterprise Group)
3	Puget Sound Energy, Inc.	Mariah R Kennedy	Affirmative	
3	Sacramento Municipal Utility District	James Leigh-Kendall	Affirmative	
3	Salt River Project	John T. Underhill	Affirmative	
3	Santee Cooper	James M Poston	Abstain	
3	Seattle City Light	Dana Wheelock	Negative	SUPPORTS THIRD PARTY COMMENTS - (Seattle City Light Paul Haase's comment)
3	Seminole Electric Cooperative, Inc.	James R Frauen	Negative	SUPPORTS THIRD PARTY COMMENTS - (Seminole Electric Cooperative)
3	Sho-Me Power Electric Cooperative	Jeff L Neas		
3	Snohomish County PUD No. 1	Mark Oens	Affirmative	
3	South Carolina Electric & Gas Co.	Hubert C Young	Affirmative	
3	Southern California Edison Company	Lujuanna Medina	Affirmative	
3	Tacoma Power	Marc Donaldson	Affirmative	
3	Tampa Electric Co.	Ronald L. Donahey		
3	Tennessee Valley Authority	Ian S Grant	Abstain	
3	Tri-State Generation & Transmission Association, Inc.	Janelle Marriott	Affirmative	
3	Westar Energy	Bo Jones	Negative	SUPPORTS THIRD PARTY COMMENTS - (SPP Standards Group)
3	Xcel Energy, Inc.	Michael Ibold	Negative	SUPPORTS THIRD PARTY COMMENTS - (Xcel Energy)
4	Alliant Energy Corp. Services, Inc.	Kenneth Goldsmith	Negative	SUPPORTS THIRD PARTY COMMENTS - (MRO NSRF)
4	Blue Ridge Power Agency	Duane S Dahlquist	Affirmative	
4	City of Austin dba Austin Energy	Reza Ebrahimian	Abstain	
4	City of Redding	Nicholas Zettel	Affirmative	
4	City Utilities of Springfield, Missouri	John Allen	Negative	SUPPORTS THIRD PARTY COMMENTS -

				(SPP Standards Review Group)
4	Consumers Energy Company	Tracy Goble	Affirmative	
4	Cowlitz County PUD	Rick Syring		
4	DTE Electric	Daniel Herring	Negative	COMMENT RECEIVED
4	Florida Municipal Power Agency	Frank Gaffney	Affirmative	
4	Georgia System Operations Corporation	Guy Andrews	Abstain	
4	Herb Schrayshuen	Herb Schrayshuen	Affirmative	
4	Illinois Municipal Electric Agency	Bob C. Thomas	Abstain	
4	Indiana Municipal Power Agency	Jack Alvey	Negative	SUPPORTS THIRD PARTY COMMENTS - (comments submitted by Public Service Enterprise Group)
4	Madison Gas and Electric Co.	Joseph DePoorter	Negative	SUPPORTS THIRD PARTY COMMENTS - (MRO NSRF)
4	Modesto Irrigation District	Spencer Tacke	Negative	COMMENT RECEIVED
4	Ohio Edison Company	Douglas Hohlbaugh	Affirmative	
4	Oklahoma Municipal Power Authority	Ashley Stringer	Abstain	
4	Old Dominion Electric Coop.	Mark Ringhausen	Affirmative	
4	Public Utility District No. 1 of Snohomish County	John D Martinsen	Affirmative	
4	Sacramento Municipal Utility District	Mike Ramirez	Affirmative	
4	Seattle City Light	Hao Li	Negative	SUPPORTS THIRD PARTY COMMENTS - (Seattle City Light Paul Haase's comment)
4	Seminole Electric Cooperative, Inc.	Steven R Wallace	Negative	SUPPORTS THIRD PARTY COMMENTS - (Seminole Electric Cooperative Comments submitted by Maryclaire Yatsko)
4	South Mississippi Electric Power Association	Steve McElhaney		
4	Tacoma Public Utilities	Keith Morisette	Affirmative	
4	Utility Services, Inc.	Brian Evans-Mongeon		
5	Amerenue	Sam Dwyer	Affirmative	
5	American Electric Power	Thomas Foltz	Affirmative	
5	Arizona Public Service Co.	Scott Takinen	Affirmative	
5	Associated Electric Cooperative, Inc.	Matthew Pacobit	Negative	SUPPORTS THIRD PARTY COMMENTS - (Aeci)
5	BC Hydro and Power Authority	Clement Ma	Negative	SUPPORTS THIRD PARTY COMMENTS - (BC Hydro)
5	Boise-Kuna Irrigation District/dba Lucky peak power plant project	Mike D Kukla		
5	Bonneville Power Administration	Francis J. Halpin	Affirmative	
5	Brazos Electric Power Cooperative, Inc.	Shari Heino	Negative	SUPPORTS THIRD PARTY COMMENTS - (ACES)
5	City and County of San Francisco	Daniel Mason		
5	City of Austin dba Austin Energy	Jeanie Doty	Abstain	
5	City of Redding	Paul A. Cummings	Affirmative	
5	City of Tallahassee	Karen Webb	Abstain	
5	City Water, Light & Power of Springfield	Steve Rose		
				SUPPORTS

5	Cleco Power	Stephanie Huffman	Negative	THIRD PARTY COMMENTS - (See SPP Comments)
5	Cogentrix Energy Power Management, LLC	Mike D Hirst		
5	Colorado Springs Utilities	Kaleb Brimhall	Negative	SUPPORTS THIRD PARTY COMMENTS - (PSEG) - (Colorado Springs Utilities)
5	Con Edison Company of New York	Brian O'Boyle	Affirmative	
5	Consumers Energy Company	David C Greyerbiehl	Affirmative	
5	Cowlitz County PUD	Bob Essex		
5	Dairyland Power Coop.	Tommy Drea	Negative	SUPPORTS THIRD PARTY COMMENTS - (MRO NSRF)
5	Dominion Resources, Inc.	Mike Garton	Affirmative	
5	DTE Electric	Mark Stefaniak	Negative	SUPPORTS THIRD PARTY COMMENTS - (DTE Electric and PSEG)
5	Duke Energy	Dale Q Goodwine	Negative	SUPPORTS THIRD PARTY COMMENTS - (Duke Energy)
5	Dynegy Inc.	Dan Roethemeyer	Abstain	
5	E.ON Climate & Renewables North America, LLC	Dana Showalter		
5	Entergy Services, Inc.	Tracey Stubbs		
5	Exelon Nuclear	Mark F Draper	Affirmative	
5	First Wind	John Robertson	Negative	SUPPORTS THIRD PARTY COMMENTS - (Public Service Enterprise Group (PSEG))
5	FirstEnergy Solutions	Kenneth Dresner	Affirmative	
5	Florida Municipal Power Agency	David Schumann	Affirmative	
5	Great River Energy	Preston L Walsh	Affirmative	
5	Hydro-Québec Production	Roger Dufresne	Affirmative	
5	Ingleside Cogeneration LP	Michelle R DAntuono	Negative	COMMENT RECEIVED
5	JEA	John J Babik	Negative	COMMENT RECEIVED
5	Kansas City Power & Light Co.	Brett Holland	Negative	COMMENT RECEIVED
5	Kissimmee Utility Authority	Mike Blough		
5	Lakeland Electric	James M Howard	Affirmative	
5	Liberty Electric Power LLC	Daniel Duff	Negative	SUPPORTS THIRD PARTY COMMENTS - (Public Service Enterprise Group)
5	Lincoln Electric System	Dennis Florom	Negative	SUPPORTS THIRD PARTY COMMENTS - (MRO NSRF)
5	Los Angeles Department of Water & Power	Kenneth Silver	Abstain	
5	Lower Colorado River Authority	Dixie Wells	Affirmative	
5	Luminant Generation Company LLC	Rick Terrill		
5	Manitoba Hydro	Chris Mazur	Affirmative	
5	Massachusetts Municipal Wholesale Electric Company	David Gordon	Abstain	
5	MEAG Power	Steven Grego	Affirmative	
5	Muscatine Power & Water	Mike Avesing	Affirmative	
5	Nebraska Public Power District	Don Schmit	Negative	SUPPORTS THIRD PARTY COMMENTS - (Nebraska Public Power

				District)
5	New York Power Authority	Wayne Sipperly	Affirmative	
5	NextEra Energy	Allen D Schriver	Affirmative	
5	North Carolina Electric Membership Corp.	Jeffrey S Brame	Affirmative	
5	Northern Indiana Public Service Co.	Michael D Melvin	Abstain	
5	Oglethorpe Power Corporation	Bernard Johnson	Affirmative	
5	Oklahoma Gas and Electric Co.	Henry L Staples		
5	Omaha Public Power District	Mahmood Z. Safi	Negative	SUPPORTS THIRD PARTY COMMENTS - (MRO NSRF)
5	Pacific Gas and Electric Company	Alex Chua		
5	Platte River Power Authority	Christopher R Wood	Affirmative	
5	Portland General Electric Co.	Matt E. Jastram	Affirmative	
5	PPL Generation LLC	Annette M Bannon	Negative	SUPPORTS THIRD PARTY COMMENTS - (PPL NERC Registered Affiliates)
5	PSEG Fossil LLC	Tim Kucey	Negative	SUPPORTS THIRD PARTY COMMENTS - (PSEG (John Seelke))
5	Public Utility District No. 1 of Lewis County	Steven Grega		
5	Public Utility District No. 2 of Grant County, Washington	Michiko Sell		
5	Puget Sound Energy, Inc.	Lynda Kupfer	Affirmative	
5	Sacramento Municipal Utility District	Susan Gill-Zobitz	Affirmative	
5	Salt River Project	William Alkema	Affirmative	
5	Santee Cooper	Lewis P Pierce	Abstain	
5	Seattle City Light	Michael J. Haynes	Negative	SUPPORTS THIRD PARTY COMMENTS - (Haase, Seattle)
5	Snohomish County PUD No. 1	Sam Nietfeld	Affirmative	
5	South Carolina Electric & Gas Co.	Edward Magic	Affirmative	
5	Southern California Edison Company	Denise Yaffe	Affirmative	
5	Southern Company Generation	William D Shultz	Affirmative	
5	Tacoma Power	Chris Mattson	Affirmative	
5	Tampa Electric Co.	RJames Rocha		
5	Tenaska, Inc.	Scott M. Helyer		
5	Tennessee Valley Authority	David Thompson	Abstain	
5	Tri-State Generation & Transmission Association, Inc.	Mark Stein	Affirmative	
5	U.S. Army Corps of Engineers	Melissa Kurtz		
5	USDI Bureau of Reclamation	Erika Doot		
5	Westar Energy	Bryan Taggart	Negative	SUPPORTS THIRD PARTY COMMENTS - (SPP Comments)
5	Xcel Energy, Inc.	Mark A Castagneri	Negative	COMMENT RECEIVED
6	AEP Marketing	Edward P. Cox	Affirmative	
6	Ameren Missouri	Robert Quinlivan	Affirmative	
6	APS	Randy A. Young	Affirmative	
6	Associated Electric Cooperative, Inc.	Brian Ackermann	Negative	SUPPORTS THIRD PARTY COMMENTS - (AECI)
6	Bonneville Power Administration	Brenda S. Anderson	Affirmative	
6	City of Austin dba Austin Energy	Lisa Martin	Abstain	
6	City of Redding	Marvin Briggs	Affirmative	
6	Cleco Power LLC	Robert Hirchak	Negative	SUPPORTS THIRD PARTY COMMENTS - (See SPP Comments)
				SUPPORTS THIRD PARTY

6	Colorado Springs Utilities	Shannon Fair	Negative	COMMENTS - (Colorado Springs Utilities)
6	Con Edison Company of New York	David Balban	Affirmative	
6	Constellation Energy Commodities Group	David J Carlson	Affirmative	
6	Dominion Resources, Inc.	Louis S. Slade	Affirmative	
6	Duke Energy	Greg Cecil	Negative	SUPPORTS THIRD PARTY COMMENTS - (Duke Energy)
6	FirstEnergy Solutions	Kevin Querry	Affirmative	
6	Florida Municipal Power Agency	Richard L. Montgomery	Affirmative	
6	Florida Municipal Power Pool	Thomas Washburn		
6	Florida Power & Light Co.	Silvia P Mitchell		
6	Great River Energy	Donna Stephenson		
6	Kansas City Power & Light Co.	Jessica L Klinghoffer	Negative	COMMENT RECEIVED
6	Lakeland Electric	Paul Shipps		
6	Lincoln Electric System	Eric Ruskamp	Negative	SUPPORTS THIRD PARTY COMMENTS - (MRO NSRF)
6	Lower Colorado River Authority	Michael Shaw	Affirmative	
6	Luminant Energy	Brenda Hampton	Negative	SUPPORTS THIRD PARTY COMMENTS - (Luminant Generation Company, LLC)
6	Manitoba Hydro	Blair Mukanik	Affirmative	
6	Modesto Irrigation District	James McFall	Affirmative	
6	New York Power Authority	Shivaz Chopra	Affirmative	
6	Northern Indiana Public Service Co.	Joseph O'Brien	Abstain	
6	Oglethorpe Power Corporation	Donna Johnson	Affirmative	
6	Oklahoma Gas and Electric Co.	Jerry Nottnagel		
6	Omaha Public Power District	Douglas Collins	Negative	SUPPORTS THIRD PARTY COMMENTS - (MRO NSRF)
6	PacifiCorp	Sandra L Shaffer	Negative	COMMENT RECEIVED
6	Platte River Power Authority	Carol Ballantine	Affirmative	
6	Portland General Electric Co.	Shawn P Davis		
6	Power Generation Services, Inc.	Stephen C Knapp		
6	Powerex Corp.	Gordon Dobson-Mack	Negative	SUPPORTS THIRD PARTY COMMENTS - (BC Hydro's (Patricia Robertson's))
6	PPL EnergyPlus LLC	Elizabeth Davis	Negative	SUPPORTS THIRD PARTY COMMENTS - (PPL NERC Registered Affiliates)
6	PSEG Energy Resources & Trade LLC	Peter Dolan	Negative	SUPPORTS THIRD PARTY COMMENTS - (Public Service Enterprise Group)
6	Public Utility District No. 1 of Chelan County	Hugh A. Owen	Abstain	
6	Sacramento Municipal Utility District	Diane Enderby	Affirmative	
6	Salt River Project	William Abraham	Affirmative	
6	Santee Cooper	Michael Brown	Abstain	
6	Seattle City Light	Dennis Sismaet	Negative	SUPPORTS THIRD PARTY COMMENTS - (Paul Haase)
				SUPPORTS THIRD PARTY COMMENTS -

6	Seminole Electric Cooperative, Inc.	Trudy S. Novak	Negative	(comments submitted by Maryclaire Yatsko on behalf of Seminole Electric Cooperative, Inc.)
6	Snohomish County PUD No. 1	Kenn Backholm	Affirmative	
6	Southern California Edison Company	Joseph T Marone	Affirmative	
6	Southern Company Generation and Energy Marketing	John J. Ciza	Affirmative	
6	Tacoma Public Utilities	Michael C Hill	Affirmative	
6	Tampa Electric Co.	Benjamin F Smith II		
6	Tennessee Valley Authority	Marjorie S Parsons	Abstain	
6	Westar Energy	Grant L Wilkerson		
6	Western Area Power Administration - UGP Marketing	Peter H Kinney		
6	Xcel Energy, Inc.	Peter Colussy		
7	Occidental Chemical	Venona Greaff	Negative	SUPPORTS THIRD PARTY COMMENTS - (Ingleside Cogeneration, LP)
7	Siemens Energy, Inc.	Frank R. McElvain		
8		David L Kiguel	Affirmative	
8		Roger C Zaklukiewicz	Affirmative	
8	Massachusetts Attorney General	Frederick R Plett	Affirmative	
8	Volkman Consulting, Inc.	Terry Volkman	Negative	SUPPORTS THIRD PARTY COMMENTS - (MRO NSRF)
9	Commonwealth of Massachusetts Department of Public Utilities	Donald Nelson	Affirmative	
9	New York State Public Service Commission	Diane J Barney	Affirmative	
10	Florida Reliability Coordinating Council	Linda C Campbell	Affirmative	
10	Midwest Reliability Organization	Russel Mountjoy	Affirmative	
10	New York State Reliability Council	Alan Adamson	Affirmative	
10	Northeast Power Coordinating Council	Guy V. Zito		
10	ReliabilityFirst	Anthony E Jablonski	Affirmative	
10	SERC Reliability Corporation	Joseph W Spencer	Affirmative	
10	Southwest Power Pool RE	Bob Reynolds		
10	Texas Reliability Entity, Inc.	Karin Schweitzer	Affirmative	
10	Western Electricity Coordinating Council	Steven L. Rueckert	Affirmative	

Legal and Privacy : 404.446.2560 voice : 404.467.0474 fax : 3353 Peachtree Road, N.E. : Suite 600, North Tower : Atlanta, GA 30326  
 Washington Office: 1325 G Street, N.W. : Suite 600 : Washington, DC 20005-3801

[Account Log-In/Register](#)

Copyright © 2014 by the North American Electric Reliability Corporation. : All rights reserved.  
 A New Jersey Nonprofit Corporation

## Non-Binding Poll Results

Project 2010-13.3 Phase 3 of Relay Loadability: Stable  
Power Swings  
PRC-026-1

Non-Binding Poll Results	
<b>Non-Binding Poll Name:</b>	Project 2010-13.3 Relay Loadability Stable Power Swings PRC-026-1
<b>Poll Period:</b>	11/14/2014 – 11/24/2014
<b>Total # Opinions:</b>	261
<b>Total Ballot Pool:</b>	332
<b>Summaray Results:</b>	78.61% of those who registered to participate provided an opinion or an abstention; 66.13% of those who provided an opinion indicated support for the VRFs and VSLs.

Individual Ballot Pool Results				
Segment	Organization	Member	Opinions	NERC Notes
1	Ameren Services	Eric Scott	Abstain	
1	American Electric Power	Paul B Johnson	Affirmative	
1	Arizona Public Service Co.	Robert Smith		
1	Associated Electric Cooperative, Inc.	John Bussman	Negative	SUPPORTS THIRD PARTY COMMENTS - (AECI)
1	ATCO Electric	Glen Sutton	Abstain	
1	Austin Energy	James Armke	Abstain	
1	Avista Utilities	Heather Rosentrater		
1	Balancing Authority of Northern California	Kevin Smith	Affirmative	
1	BC Hydro and Power Authority	Patricia Robertson	Abstain	



1	Brazos Electric Power Cooperative, Inc.	Tony Kroskey		
1	Bryan Texas Utilities	John C Fontenot	Negative	SUPPORTS THIRD PARTY COMMENTS - (Luminant)
1	CenterPoint Energy Houston Electric, LLC	John Brockhan	Abstain	
1	Central Electric Power Cooperative	Michael B Bax	Negative	SUPPORTS THIRD PARTY COMMENTS - (AECI)
1	Central Iowa Power Cooperative	Kevin J Lyons	Negative	SUPPORTS THIRD PARTY COMMENTS - (ACES)
1	City of Tacoma, Department of Public Utilities, Light Division, dba Tacoma Power	Chang G Choi	Affirmative	
1	City of Tallahassee	Daniel S Langston	Abstain	
1	Clark Public Utilities	Jack Stamper	Affirmative	
1	Colorado Springs Utilities	Shawna Speer	Negative	SUPPORTS THIRD PARTY COMMENTS - (Colorado Springs Utilities)
1	Consolidated Edison Co. of New York	Christopher L de Graffenried	Affirmative	
1	CPS Energy	Glenn Pressler	Negative	SUPPORTS THIRD PARTY COMMENTS - (Luminant)
1	Dairyland Power Coop.	Robert W. Roddy	Negative	SUPPORTS THIRD PARTY COMMENTS - (NSRF)

1	Deseret Power	James Tucker	Abstain	
1	Dominion Virginia Power	Larry Nash	Abstain	
1	Duke Energy Carolina	Doug E Hils	Negative	SUPPORTS THIRD PARTY COMMENTS - (Duke Energy)
1	Empire District Electric Co.	Ralph F Meyer	Abstain	
1	Encari	Steven E Hamburg		
1	Entergy Transmission	Oliver A Burke	Negative	COMMENT RECEIVED
1	FirstEnergy Corp.	William J Smith	Affirmative	
1	Florida Keys Electric Cooperative Assoc.	Dennis Minton		
1	Florida Power & Light Co.	Mike O'Neil	Affirmative	
1	Gainesville Regional Utilities	Richard Bachmeier		
1	Georgia Transmission Corporation	Jason Snodgrass	Negative	SUPPORTS THIRD PARTY COMMENTS - (ACES)
1	Great River Energy	Gordon Pietsch	Affirmative	
1	Hydro One Networks, Inc.	Muhammed Ali	Affirmative	
1	Hydro-Quebec TransEnergie	Martin Boisvert	Affirmative	
1	Idaho Power Company	Molly Devine	Affirmative	
1	International Transmission Company Holdings Corp	Michael Moltane		
1	JDRJC Associates	Jim D Cyrulewski	Abstain	
1	JEA	Ted E Hobson	Negative	COMMENT RECEIVED
1	KAMO Electric Cooperative	Walter Kenyon	Negative	SUPPORTS THIRD PARTY COMMENTS - (AECI)
1	Kansas City Power & Light Co.	Daniel Gibson	Negative	COMMENT RECEIVED
1	Lakeland Electric	Larry E Watt		
1	Lee County Electric Cooperative	John Chin		

1	Los Angeles Department of Water & Power	faranak sarbaz	Abstain	
1	Lower Colorado River Authority	Martyn Turner	Affirmative	
1	Manitoba Hydro	Jo-Anne M Ross	Affirmative	
1	MEAG Power	Danny Dees	Affirmative	
1	MidAmerican Energy Co.	Terry Harbour	Negative	SUPPORTS THIRD PARTY COMMENTS - (MRO NSRF)
1	Minnkota Power Coop. Inc.	Daniel L Inman	Negative	SUPPORTS THIRD PARTY COMMENTS - (see NSRF's Comments)
1	N.W. Electric Power Cooperative, Inc.	Mark Ramsey	Negative	SUPPORTS THIRD PARTY COMMENTS - (AECI)
1	National Grid USA	Michael Jones	Affirmative	
1	NB Power Corporation	Alan MacNaughton	Abstain	
1	Nebraska Public Power District	Jamison Cawley	Abstain	
1	New York Power Authority	Bruce Metruck	Affirmative	
1	Northeast Missouri Electric Power Cooperative	Kevin White	Negative	SUPPORTS THIRD PARTY COMMENTS - (AECI)
1	Northeast Utilities	William Temple	Affirmative	
1	Northern Indiana Public Service Co.	Julaine Dyke	Abstain	
1	NorthWestern Energy	John Canavan		
1	Ohio Valley Electric Corp.	Scott R Cunningham	Affirmative	
1	Oklahoma Gas and Electric Co.	Terri Pyle		
1	Omaha Public Power District	Doug Peterchuck	Negative	SUPPORTS THIRD PARTY COMMENTS - (MRO NSRF)
1	Oncor Electric Delivery	Jen Fiegel	Affirmative	

1	Otter Tail Power Company	Daryl Hanson	Negative	SUPPORTS THIRD PARTY COMMENTS - (MRO NSRF)
1	Pacific Gas and Electric Company	Bangalore Vijayraghavan		
1	Peak Reliability	Jared Shakespeare		
1	Platte River Power Authority	John C. Collins	Abstain	
1	Portland General Electric Co.	John T Walker	Affirmative	
1	PPL Electric Utilities Corp.	Brenda L Truhe	Negative	SUPPORTS THIRD PARTY COMMENTS - (Refer to comments submitted on behalf of PPL NERC Registered Affiliates)
1	Public Service Company of New Mexico	Laurie Williams		
1	Public Service Electric and Gas Co.	Kenneth D. Brown	Abstain	
1	Public Utility District No. 1 of Okanogan County	Dale Dunckel	Abstain	
1	Puget Sound Energy, Inc.	Denise M Lietz	Affirmative	
1	Rochester Gas and Electric Corp.	John C. Allen	Abstain	
1	Sacramento Municipal Utility District	Tim Kelley	Affirmative	
1	Salt River Project	Robert Kondziolka	Affirmative	
1	SaskPower	Wayne Guttormson	Abstain	
1	Seminole Electric Cooperative, Inc.	Glenn Spurlock	Abstain	
1	Sho-Me Power Electric Cooperative	Denise Stevens		
1	Snohomish County PUD No. 1	Long T Duong	Affirmative	
1	South Carolina Electric & Gas Co.	Tom Hanzlik	Affirmative	
1	South Carolina Public Service Authority	Shawn T Abrams	Abstain	
1	Southern California Edison Company	Steven Mavis	Affirmative	

1	Southern Company Services, Inc.	Robert A. Schaffeld	Affirmative	
1	Southern Illinois Power Coop.	William Hutchison		
1	Southwest Transmission Cooperative, Inc.	John Shaver	Negative	SUPPORTS THIRD PARTY COMMENTS - (ACES)
1	Sunflower Electric Power Corporation	Noman Lee Williams		
1	Tampa Electric Co.	Beth Young		
1	Tennessee Valley Authority	Howell D Scott	Abstain	
1	Trans Bay Cable LLC	Steven Powell	Affirmative	
1	Tri-State Generation & Transmission Association, Inc.	Tracy Sliman	Affirmative	
1	Tucson Electric Power Co.	John Tolo		
1	U.S. Bureau of Reclamation	Richard T Jackson		
1	United Illuminating Co.	Jonathan Appelbaum	Affirmative	
1	Vermont Electric Power Company, Inc.	Kim Moulton		
1	Westar Energy	Allen Klassen	Negative	SUPPORTS THIRD PARTY COMMENTS - (SPP Standards Group)
1	Western Area Power Administration	Lloyd A Linke		
1	Wolverine Power Supply Coop., Inc.	Michelle Clements		
2	BC Hydro	Venkataramakrishnan Vinnakota	Abstain	
2	California ISO	Rich Vine	Negative	COMMENT RECEIVED
2	Electric Reliability Council of Texas, Inc.	Cheryl Moseley	Affirmative	
2	Independent Electricity System Operator	Leonard Kula	Affirmative	
2	ISO New England, Inc.	Matthew F Goldberg	Affirmative	
2	MISO	Marie Knox	Affirmative	

2	New York Independent System Operator	Gregory Campoli		
2	PJM Interconnection, L.L.C.	stephanie monzon	Affirmative	
2	Southwest Power Pool, Inc.	Charles H. Yeung	Abstain	
3	AEP	Michael E DeLoach	Affirmative	
3	Alabama Power Company	Robert S Moore	Affirmative	
3	Ameren Corp.	David J Jendras	Abstain	
3	APS	Sarah Kist		
3	Associated Electric Cooperative, Inc.	Todd Bennett	Negative	SUPPORTS THIRD PARTY COMMENTS - (AECI)
3	Avista Corp.	Scott J Kinney	Abstain	
3	BC Hydro and Power Authority	Pat G. Harrington	Abstain	
3	Central Electric Power Cooperative	Adam M Weber		
3	City of Austin dba Austin Energy	Andrew Gallo	Affirmative	
3	City of Clewiston	Lynne Mila	Affirmative	
3	City of Farmington	Linda R Jacobson	Abstain	
3	City of Green Cove Springs	Mark Schultz	Affirmative	
3	City of Tallahassee	Bill R Fowler	Abstain	
3	Colorado Springs Utilities	Jean Mueller	Negative	SUPPORTS THIRD PARTY COMMENTS - (Kaleb Brimhall)
3	Consolidated Edison Co. of New York	Peter T Yost	Affirmative	
3	Consumers Energy Company	Gerald G Farringer	Affirmative	
3	Cowlitz County PUD	Russell A Noble		
3	CPS Energy	Jose Escamilla		
3	Dominion Resources, Inc.	Connie B Lowe	Abstain	
3	DTE Electric	Kent Kujala	Negative	COMMENT RECEIVED
3	FirstEnergy Corp.	Cindy E Stewart	Affirmative	
3	Florida Keys Electric Cooperative	Tom B Anthony	Abstain	
3	Florida Municipal Power Agency	Joe McKinney	Affirmative	

3	Florida Power & Light Co.	Summer C. Esquerre	Affirmative	
3	Florida Power Corporation	Lee Schuster	Negative	SUPPORTS THIRD PARTY COMMENTS - (Duke Energy)
3	Georgia System Operations Corporation	Scott McGough		
3	Great River Energy	Brian Glover	Affirmative	
3	Hydro One Networks, Inc.	Ayesha Sabouba	Affirmative	
3	JEA	Garry Baker		
3	Kansas City Power & Light Co.	Joshua D Bach	Negative	COMMENT RECEIVED
3	Lakeland Electric	Mace D Hunter		
3	Lee County Electric Cooperative	David A Hadzima		
3	Lincoln Electric System	Jason Fortik		
3	Los Angeles Department of Water & Power	Mike Anctil	Abstain	
3	Louisville Gas and Electric Co.	Charles A. Freibert		
3	Manitoba Hydro	Greg C. Parent	Affirmative	
3	MEAG Power	Roger Brand	Affirmative	
3	MidAmerican Energy Co.	Thomas C. Mielnik	Abstain	
3	Modesto Irrigation District	Jack W Savage	Affirmative	
3	Muscatine Power & Water	John S Bos		
3	National Grid USA	Brian E Shanahan	Affirmative	
3	Nebraska Public Power District	Tony Eddleman	Abstain	
3	New York Power Authority	David R Rivera	Affirmative	
3	Northern Indiana Public Service Co.	Ramon J Barany	Abstain	
3	NW Electric Power Cooperative, Inc.	David McDowell		
3	Ocala Utility Services	Randy Hahn	Affirmative	
3	Oklahoma Gas and Electric Co.	Donald Hargrove		
3	Omaha Public Power District	Blaine R. Dinwiddie	Negative	SUPPORTS THIRD PARTY COMMENTS - (MRO NSRF comments)

3	Orlando Utilities Commission	Ballard K Mutters	Abstain	
3	Owensboro Municipal Utilities	Thomas T Lyons	Affirmative	
3	Pacific Gas and Electric Company	John H Hagen	Affirmative	
3	Platte River Power Authority	Terry L Baker	Abstain	
3	PNM Resources	Michael Mertz	Abstain	
3	Portland General Electric Co.	Thomas G Ward	Affirmative	
3	Public Service Electric and Gas Co.	Jeffrey Mueller	Abstain	
3	Puget Sound Energy, Inc.	Mariah R Kennedy	Affirmative	
3	Sacramento Municipal Utility District	James Leigh-Kendall	Affirmative	
3	Salt River Project	John T. Underhill	Affirmative	
3	Santee Cooper	James M Poston	Abstain	
3	Seminole Electric Cooperative, Inc.	James R Frauen	Abstain	
3	Sho-Me Power Electric Cooperative	Jeff L Neas		
3	Snohomish County PUD No. 1	Mark Oens	Affirmative	
3	South Carolina Electric & Gas Co.	Hubert C Young	Affirmative	
3	Southern California Edison Company	Lujuanna Medina	Affirmative	
3	Tacoma Power	Marc Donaldson	Affirmative	
3	Tampa Electric Co.	Ronald L. Donahey		
3	Tennessee Valley Authority	Ian S Grant	Abstain	
3	Tri-State Generation & Transmission Association, Inc.	Janelle Marriott	Affirmative	
3	Westar Energy	Bo Jones	Negative	SUPPORTS THIRD PARTY COMMENTS - (SPP Standards Group)
3	Xcel Energy, Inc.	Michael Ibold	Abstain	
4	Alliant Energy Corp. Services, Inc.	Kenneth Goldsmith	Negative	SUPPORTS THIRD PARTY COMMENTS - (MRO NSRF)
4	Blue Ridge Power Agency	Duane S Dahlquist	Affirmative	
4	City of Austin dba Austin Energy	Reza Ebrahimian	Abstain	
4	City Utilities of Springfield, Missouri	John Allen	Abstain	



4	Consumers Energy Company	Tracy Goble	Affirmative	
4	Cowlitz County PUD	Rick Syring		
4	DTE Electric	Daniel Herring	Negative	COMMENT RECEIVED
4	Florida Municipal Power Agency	Frank Gaffney	Affirmative	
4	Georgia System Operations Corporation	Guy Andrews	Abstain	
4	Herb Schrayshuen	Herb Schrayshuen	Affirmative	
4	Illinois Municipal Electric Agency	Bob C. Thomas	Abstain	
4	Indiana Municipal Power Agency	Jack Alvey	Negative	SUPPORTS THIRD PARTY COMMENTS - (comments submitted by Public Service Enterprise Group)
4	Madison Gas and Electric Co.	Joseph DePoorter	Abstain	
4	Modesto Irrigation District	Spencer Tacke		
4	Ohio Edison Company	Douglas Hohlbaugh	Affirmative	
4	Public Utility District No. 1 of Snohomish County	John D Martinsen	Affirmative	
4	Sacramento Municipal Utility District	Mike Ramirez	Affirmative	
4	Seminole Electric Cooperative, Inc.	Steven R Wallace	Abstain	
4	South Mississippi Electric Power Association	Steve McElhaney		
4	Tacoma Public Utilities	Keith Morisette	Affirmative	
4	Utility Services, Inc.	Brian Evans-Mongeon		
5	Amerenue	Sam Dwyer	Abstain	
5	American Electric Power	Thomas Foltz	Affirmative	
5	Arizona Public Service Co.	Scott Takinen	Affirmative	
5	BC Hydro and Power Authority	Clement Ma	Negative	SUPPORTS THIRD PARTY COMMENTS - (BC Hydro)

5	Boise-Kuna Irrigation District/dba Lucky peak power plant project	Mike D Kukla		
5	Bonneville Power Administration	Francis J. Halpin	Affirmative	
5	Brazos Electric Power Cooperative, Inc.	Shari Heino	Negative	SUPPORTS THIRD PARTY COMMENTS - (ACES)
5	City and County of San Francisco	Daniel Mason		
5	City of Austin dba Austin Energy	Jeanie Doty	Abstain	
5	City of Tallahassee	Karen Webb	Abstain	
5	City Water, Light & Power of Springfield	Steve Rose		
5	Cleco Power	Stephanie Huffman	Negative	SUPPORTS THIRD PARTY COMMENTS - (See SPP Comments)
5	Cogentrix Energy Power Management, LLC	Mike D Hirst		
5	Colorado Springs Utilities	Kaleb Brimhall	Negative	SUPPORTS THIRD PARTY COMMENTS - (Colorado Springs Utilities)
5	Con Edison Company of New York	Brian O'Boyle	Affirmative	
5	Consumers Energy Company	David C Greyerbiehl	Affirmative	
5	Cowlitz County PUD	Bob Essex		
5	Dairyland Power Coop.	Tommy Drea	Negative	SUPPORTS THIRD PARTY COMMENTS - (MRO NSRF)
5	Dominion Resources, Inc.	Mike Garton	Abstain	
5	DTE Electric	Mark Stefaniak	Negative	SUPPORTS THIRD PARTY COMMENTS -

				(DTE Electric and PSEG)
5	Duke Energy	Dale Q Goodwine	Negative	SUPPORTS THIRD PARTY COMMENTS - (Duke Energy)
5	Dynegy Inc.	Dan Roethemeyer	Abstain	
5	E.ON Climate & Renewables North America, LLC	Dana Showalter		
5	Entergy Services, Inc.	Tracey Stubbs		
5	First Wind	John Robertson	Negative	SUPPORTS THIRD PARTY COMMENTS - (Public Service Enterprise Group (PSEG))
5	FirstEnergy Solutions	Kenneth Dresner	Affirmative	
5	Florida Municipal Power Agency	David Schumann	Affirmative	
5	Great River Energy	Preston L Walsh	Affirmative	
5	Hydro-Québec Production	Roger Dufresne	Affirmative	
5	Ingleside Cogeneration LP	Michelle R DAntuono	Negative	COMMENT RECEIVED
5	JEA	John J Babik	Negative	COMMENT RECEIVED
5	Kansas City Power & Light Co.	Brett Holland	Negative	COMMENT RECEIVED
5	Kissimmee Utility Authority	Mike Blough		
5	Liberty Electric Power LLC	Daniel Duff	Negative	SUPPORTS THIRD PARTY COMMENTS - (Public Service Enterprise Group)
5	Lincoln Electric System	Dennis Florum	Abstain	

5	Los Angeles Department of Water & Power	Kenneth Silver	Abstain	
5	Lower Colorado River Authority	Dixie Wells	Affirmative	
5	Luminant Generation Company LLC	Rick Terrill		
5	Manitoba Hydro	Chris Mazur	Affirmative	
5	Massachusetts Municipal Wholesale Electric Company	David Gordon	Abstain	
5	MEAG Power	Steven Grego	Affirmative	
5	Muscatine Power & Water	Mike Avesing	Affirmative	
5	Nebraska Public Power District	Don Schmit	Abstain	
5	New York Power Authority	Wayne Sipperly	Affirmative	
5	NextEra Energy	Allen D Schriver	Affirmative	
5	North Carolina Electric Membership Corp.	Jeffrey S Brame	Affirmative	
5	Northern Indiana Public Service Co.	Michael D Melvin	Abstain	
5	Oglethorpe Power Corporation	Bernard Johnson	Negative	SUPPORTS THIRD PARTY COMMENTS - (SERC PCS)
5	Oklahoma Gas and Electric Co.	Henry L Staples		
5	Omaha Public Power District	Mahmood Z. Safi	Negative	SUPPORTS THIRD PARTY COMMENTS - (MRO NSRF)
5	Pacific Gas and Electric Company	Alex Chua		
5	Platte River Power Authority	Christopher R Wood	Abstain	
5	Portland General Electric Co.	Matt E. Jastram	Affirmative	
5	PPL Generation LLC	Annette M Bannon	Negative	SUPPORTS THIRD PARTY COMMENTS - (PPL NERC Registered Affiliates)
5	PSEG Fossil LLC	Tim Kucey	Abstain	
5	Public Utility District No. 1 of Lewis County	Steven Grega		

5	Public Utility District No. 2 of Grant County, Washington	Michiko Sell		
5	Puget Sound Energy, Inc.	Lynda Kupfer	Affirmative	
5	Sacramento Municipal Utility District	Susan Gill-Zobitz	Affirmative	
5	Salt River Project	William Alkema	Affirmative	
5	Santee Cooper	Lewis P Pierce	Abstain	
5	Seattle City Light	Michael J. Haynes	Negative	SUPPORTS THIRD PARTY COMMENTS - (Haase, Seattle)
5	Snohomish County PUD No. 1	Sam Nietfeld	Affirmative	
5	South Carolina Electric & Gas Co.	Edward Magic	Affirmative	
5	Southern California Edison Company	Denise Yaffe	Affirmative	
5	Southern Company Generation	William D Shultz	Affirmative	
5	Tacoma Power	Chris Mattson	Affirmative	
5	Tampa Electric Co.	RJames Rocha		
5	Tenaska, Inc.	Scott M. Helyer		
5	Tennessee Valley Authority	David Thompson	Abstain	
5	Tri-State Generation & Transmission Association, Inc.	Mark Stein	Abstain	
5	U.S. Army Corps of Engineers	Melissa Kurtz		
5	USDI Bureau of Reclamation	Erika Doot		
5	Xcel Energy, Inc.	Mark A Castagneri	Negative	COMMENT RECEIVED
6	AEP Marketing	Edward P. Cox	Affirmative	
6	Ameren Missouri	Robert Quinlivan	Abstain	
6	APS	Randy A. Young	Affirmative	
6	Associated Electric Cooperative, Inc.	Brian Ackermann	Negative	SUPPORTS THIRD PARTY COMMENTS - (AECI)
6	Bonneville Power Administration	Brenda S. Anderson	Affirmative	
6	City of Austin dba Austin Energy	Lisa Martin	Abstain	

6	Cleco Power LLC	Robert Hirschak	Negative	SUPPORTS THIRD PARTY COMMENTS - (See SPP Comments)
6	Colorado Springs Utilities	Shannon Fair	Negative	SUPPORTS THIRD PARTY COMMENTS - (Colorado Springs Utilities)
6	Con Edison Company of New York	David Balban	Affirmative	
6	Duke Energy	Greg Cecil	Negative	SUPPORTS THIRD PARTY COMMENTS - (Duke Energy)
6	FirstEnergy Solutions	Kevin Querry	Affirmative	
6	Florida Municipal Power Agency	Richard L. Montgomery	Affirmative	
6	Florida Municipal Power Pool	Thomas Washburn		
6	Florida Power & Light Co.	Silvia P Mitchell		
6	Great River Energy	Donna Stephenson		
6	Kansas City Power & Light Co.	Jessica L Klinghoffer	Negative	COMMENT RECEIVED
6	Lakeland Electric	Paul Shipps		
6	Lincoln Electric System	Eric Ruskamp	Abstain	
6	Lower Colorado River Authority	Michael Shaw	Affirmative	
6	Luminant Energy	Brenda Hampton	Negative	SUPPORTS THIRD PARTY COMMENTS - (Luminant Generation Company, LLC)
6	Manitoba Hydro	Blair Mukanik	Affirmative	
6	Modesto Irrigation District	James McFall	Affirmative	
6	New York Power Authority	Shivaz Chopra	Affirmative	

6	Northern Indiana Public Service Co.	Joseph O'Brien	Abstain	
6	Oglethorpe Power Corporation	Donna Johnson	Negative	SUPPORTS THIRD PARTY COMMENTS - (GTC)
6	Oklahoma Gas and Electric Co.	Jerry Nottnagel		
6	Omaha Public Power District	Douglas Collins	Negative	SUPPORTS THIRD PARTY COMMENTS - (MRO NSRF)
6	PacifiCorp	Sandra L Shaffer	Abstain	
6	Platte River Power Authority	Carol Ballantine	Abstain	
6	Portland General Electric Co.	Shawn P Davis		
6	Power Generation Services, Inc.	Stephen C Knapp		
6	Powerex Corp.	Gordon Dobson-Mack	Negative	SUPPORTS THIRD PARTY COMMENTS - (BC Hydro's)
6	PPL EnergyPlus LLC	Elizabeth Davis	Negative	SUPPORTS THIRD PARTY COMMENTS - (PPL NERC Registered Affiliates)
6	PSEG Energy Resources & Trade LLC	Peter Dolan	Abstain	
6	Sacramento Municipal Utility District	Diane Enderby	Affirmative	
6	Salt River Project	William Abraham	Affirmative	
6	Santee Cooper	Michael Brown	Abstain	
6	Seattle City Light	Dennis Sismaet	Negative	SUPPORTS THIRD PARTY COMMENTS - (Paul Haase)
6	Seminole Electric Cooperative, Inc.	Trudy S. Novak	Abstain	
6	Snohomish County PUD No. 1	Kenn Backholm	Affirmative	
6	Southern California Edison Company	Joseph T Marone	Affirmative	

6	Southern Company Generation and Energy Marketing	John J. Ciza	Affirmative	
6	Tacoma Public Utilities	Michael C Hill	Affirmative	
6	Tampa Electric Co.	Benjamin F Smith II		
6	Tennessee Valley Authority	Marjorie S Parsons	Abstain	
6	Western Area Power Administration - UGP Marketing	Peter H Kinney		
7	Occidental Chemical	Venona Greaff	Negative	SUPPORTS THIRD PARTY COMMENTS - (Ingleside Cogeneration, LP)
8		David L Kiguel	Affirmative	
8		Roger C Zaklukiewicz	Affirmative	
8	Massachusetts Attorney General	Frederick R Plett	Affirmative	
8	Volkman Consulting, Inc.	Terry Volkman	Negative	SUPPORTS THIRD PARTY COMMENTS - (MRO NSRF)
9	Commonwealth of Massachusetts Department of Public Utilities	Donald Nelson	Affirmative	
10	Florida Reliability Coordinating Council	Linda C Campbell	Affirmative	
10	Midwest Reliability Organization	Russel Mountjoy	Affirmative	
10	New York State Reliability Council	Alan Adamson	Affirmative	
10	Northeast Power Coordinating Council	Guy V. Zito		
10	ReliabilityFirst	Anthony E Jablonski	Affirmative	
10	SERC Reliability Corporation	Joseph W Spencer	Affirmative	
10	Southwest Power Pool RE	Bob Reynolds		
10	Texas Reliability Entity, Inc.	Karin Schweitzer	Affirmative	
10	Western Electricity Coordinating Council	Steven L. Rueckert	Abstain	



**Individual or group. (42 Responses)**

**Name (24 Responses)**

**Organization (24 Responses)**

**Group Name (18 Responses)**

**Lead Contact (18 Responses)**

**Question 1 (38 Responses)**

Individual
Alshare Hughes
Luminant Generation Company, LLC
Luminant continues to believe that including unstable power swings in the draft standard goes beyond FERC Order 733. Luminant understands that adding unstable power swings in the Requirement only requires the Generator Owner to be compliant with the criteria in Requirement R3 (Attachment B) for any of the load-responsive relays in Attachment A. However, Requirement R1 (part 4) provides information to the Generator Owner that some units may be subject to an out-of-step condition and action on their part may be necessary to enable generator out-of-step protection. Luminant recommends that either "unstable" be removed from the standard in all requirements or add language to Measure M1 for the Planning Coordinator to provide information (for example, impedance plots) to the Generator Owner that describe the location of the electrical center for an out-of-step condition.
Individual
Maryclaire Yatsko
Seminole Electric Cooperative, Inc.
Requirement R1 "Element" in R1 on page 6 of the redline was revised to "generator, transformer, and transmission line BES Element." It's unclear whether "transmission line BES Element" includes terminal equipment of the transmission line. It's unclear whether a "generator BES Element" includes a generator Facility, i.e., the generator itself or merely those Elements that make up the generator. Seminole requests the drafting team add additional language as to what is actually covered under R1. PRC-026-1 – Attachment B Under Criteria B on page 20 of the redline version, #2 states "All generation is in service and all transmission BES Elements are in their normal ... ." Seminole requests the drafting team explain how the "transmission BES Elements" listed here are different than "Transmission BES Elements" (Transmission with a capital T)?
Individual
Reena Dhir
Manitoba Hydro
Individual
Andrew Z. Pusttai
American Transmission Company, LLC
ATC accepts the SDT changes.
Group
MRO NERC Standards Review Forum
Joe DePoorter
The NSRF believes that the Industry concerns have not been adequately addressed. Request that the drafting clarify its scope of applicability between NERC defined "Elements" and "Facilities" in Section 4.2. Did the drafting team mean only BES generators, transmission lines, and transformers? If so, please clarify this sub set is the only applicable items. The drafting team should eliminate or revise criterion 3 under PRC-026-1 R1. UFLS islands are rare and UFLS islands mandated by PRC-006 are likely best guess conditions. Therefore unless criterion 3 under R1 is modified to apply only to known and designed stability power protection systems, the work performed would be a best guess and of little practical value. At a minimum, criterion 3 could be further clarified by adding a sentence such as the following, "Criterion 3 does not apply to other conditions such as excessive

loading.” FERC has defined that the requirements govern compliance (FERC O 693 sect. 253), unless the words “non-fault power swings” are added to R2 similar to the PRC-026 purpose correctly limiting the number of evaluations to non-fault conditions, a regulatory entity could determine an entity was in non-compliance for not evaluating stable or unstable power swings for fault conditions after an event for “impedance based relays identified in Attachment The use of “non-fault” in PRC-026 R2 would clearly separate PRC-026 from PRC-004 which already governs analysis and corrective actions for protection systems mis-operations usually with respect to fault conditions. This separation will avoid a potential double jeopardy violation where PRC-026 and PRC-004 could be interpreted to overlap for relay analysis of a misoperation. Concerns could exist for electromechanical relays. Electromechanical relays do not provide appropriate data to verify operation or misoperation due to a stable or unstable power swing. Electromechanical relays can only provide target data. To verify correct operation due to a stable or unstable power swing, plots of the system impedance characteristic need to be obtained. Suggest that requirement 2.3 be added clearly identifying that limited data where it isn’t possible to verify if a relay tripped due to a power swing, the entity can conclude it is unaware of the trip cause and a PRC-026 report isn’t required or use of a foot note could be added.

Individual

David Jendras

Ameren

Individual

John Seelke

Public Service Enterprise Group

As explained below, we believe there are two unresolved issues. Background PRC-004-3 overlaps PRC-026-1 in several areas. In PRC-004-3, GOs and TOs examine each operation its BES interruption devices to identify Misoperations. Under R5, they must develop a Corrective Action Plan (CAP) unless they “Explain in a declaration why corrective actions are beyond the entity’s control or would not improve BES reliability, and that no further corrective actions will be taken.” In the process of implementing PRC-004-3, “correct operations” are also identified (i.e., interrupting device operations where a Misoperation DID NOT occur), but PRC-004-3 imposes no requirements on correct operations. Misoperations A relay operation during a stable power swing under subpart 2.2 of PRC-026-1 is a Misoperation reportable under PRC-004-3 and subject to a CAP under R5. This same relay operation would be subject to a CAP under R3 of PRC-026-1. In addition, the CAP timelines are different (60 days to develop a CAP in PRC-004-3 and six months to develop it in PRC-026-1). Two standards should not contain requirements that apply to the same Misoperation. To avoid this, we recommend that a new subpart 3.1 should be added in PRC-026-1 as follows: R3.1 The development of a CAP pursuant to Requirement R3 shall supersede the requirements for a Generator Owner or Transmission Owner to develop and implement a CAP for a Misoperation pursuant to NERC Reliability Standard PRC-004. Correct operations Subpart 2.2 of PRC-026-1 also requires knowledge of correct relay operations due to an unstable power swing. As explained above, this information is directly derived from PRC-004-3, but performing a power swing analysis for each correct relay operation would be very burdensome to meet subpart 2.2. The “becoming aware of” language in subpart 2.2 is explained in the Application Guidelines on p. 22 of the standard. This explanation removes the onus of an entity being required to examine each relay operation for the presence of a power swing. We recommend the standard add a footnote to subpart 2.2 that states: “See p. 22 for an explanation of implementing the “becoming aware” language in subpart 2.2.” Because a guideline is not enforceable, such a footnote would tie this guideline language solidly to subpart 2.2.

Individual

Michelle D’Antuono

Ingleside Cogeneration LP

Ingleside Cogeneration L.P. (ICLP) has carefully read through the latest draft of PRC-026-1 and its supporting documents, but still must deliver a “No” vote. We fully understand the regulatory need to adhere to FERC’s December 31 deadline, but believe that the intent of the drafting team is not captured in the enforceable parts of the standard itself. On a positive note, this means that we believe that the technical aspects of PRC-026-1 are sound – which means that the most difficult work has been performed. ICLP would like to compliment the project team on their ability to construct a process that narrows the universe of load relays that may improperly react to stable

power swings, offsetting the arguments that the standard does not serve a reliability purpose. However, several key logistical issues remain. In our view, if these remain uncorrected, we cannot be sure that CEAs will administer the standard evenly across all eight Regions. Our specific recommendations are as follows: 1) There must be clarity in the methods used to identify load relay that react improperly to a stable or unstable power swing. The project team has articulated in their Consideration of Comments that Events Analysis and/or a PRC-004 Misoperation study are the triggers that they visualize. However, these concepts are not binding to CEAs – who we believe will demand evidence that every load relay trip was investigated and proved to be not-applicable. In addition, a TO or GO who does not properly identify a stable or unstable power swing will be held in violation of PRC-026-1. This is not a capability or expertise that equipment owners possess, and should not be held accountable for. The project team resolved a similar issue by adding a footnote reference to FAC-010 in R1, and ICLP believes that the same could be done for R2. The footnote would simply capture the fact that the potentially deficient load relay would be identified through the Events Analysis process and/or a Misoperation study. 2) The project team has made it clear that a trip in response to an unstable power swing is a screening factor – not a deficient condition. However, no change has been made despite multiple requests to do so. Perhaps the project team believes that there is already sufficient clarity in the requirements, but ICLP disagrees. As written, we believe that some CEAs will demand corrective action in response to an unstable power swing – an improper use of scarce resources better applied elsewhere. A modification to R2 to address the screening intent of unstable power swings can be easily done in order to avoid this situation.

Individual

Kayleigh Wilkerson

Lincoln Electric System

Individual

Oliver Burke

Entergy Services, Inc.

Based on the information contained in the SPCS Power Swing Report Dated August 2013, there is insufficient evidence contained in the historical study cases identified, to warrant implementation of the proposed PRC-026-1 standard."

Individual

John Merrell

Tacoma Power

In general, Tacoma Power agrees that the Power Swings Standard Drafting Team has addressed industry comments in such a manner that industry consensus can be achieved. However, Tacoma Power does have some other relatively minor suggestions. (In general, these comments were identified by reviewing the draft with redlines.) 1. Consider modifying Requirement R3 as follows. Change "...does not meet the PRC-026-1 – Attachment B criteria..." to "...does not meet the PRC-026-1 – Attachment B criteria pursuant to Requirement R2..." This may be implied, but the language in Requirement R3 does not tie back to Requirement R2. 2. In the Rationale for R3, it seems like the reference to Requirement R2 should be a reference to Requirement R3. 3. The criteria headings in Attachment B should read as Criterion A and Criterion B. 4. Under Attachment B, Criterion B, Condition 2, all transmission BES Elements cannot be in their normal operating state if the parallel transfer impedance has been removed. It is understood that all transmission BES Elements would be in their normal operating state with the exception that the parallel transfer impedance should be removed.

Group

Northeast Power Coordinating Council

Guy Zito

With respect to Requirement 1, stability addressed by RAS (Criterion 1), or relay trips observed in Planning Assessments (Criterion 4) often involves remote or local generators and the instability or relay trip does not impact the Bulk Electric System outside the local area. In NPCC, the majority of RAS are classified as Type III SPS, meaning that their failure (and resulting instability) does not adversely impact the Bulk Electric System outside the local area. As in PRC-010-1 that recognizes local issues and "provides latitude for the Planning Coordinator or Transmission Planner to determine if UVLS falls under the defined term based on the impact on the reliability of the BES", it is

suggested that PRC-026-1 also provide latitude to the PC to exclude some of the BES Elements identified by Criteria 1 and 4 if the instability or relay trip does not impact the Bulk Electric System outside the local area. The page numbers refer to the pages in the clean copy of PRC-026-1. Page 14--from "The following protection functions are excluded from Requirements of this standard:", Why are voltage-restrained relays excluded? Wouldn't the voltage dip during a power swing enable these relays to misoperate on load current? Page 18--in the "Pole Slip:" item it should read "a generator's, or group of generator's, terminal...". Page 18--the "Out-of-step Condition:" should read "Same as an Unstable Power Swing." (Capitalization change). Page 20--line 5 should reads "...identified as BES Elements meeting...". Page 30--the caption for Figure 3 should read: "System impedances as seen by Relay R. (voltage connections for relay not shown.)" Page 33-- The first blue box for Table 2 should read: "Positive sequence impedance data (with transfer impedance ZTR set to a very large value)." Page 33--In equation (8), ZTR was given as  $= ZL \times 10^{10}$ , which equals  $(4 + j20) \times 10^{10}$ , not  $(4 + j20)^{10}$  as used in the equations. Page 34--In Table 3, the second blue box should read: "Positive sequence impedance data (with transfer impedance ZTR set to a very large value). Page 36--same comment for Equation (16) as for Equation (8) above. Page 36--for Table 4 and Equation (24), the same comment as for Equation (8) above. Pages 38-42--for Tables 5, 6, and 7 the same comment as for Equation (8) above. Page 53--For Figure 12 the caption should be rephrased to: "The tripping portion of the mho element characteristic not blocked by load encroachment (i.e., ...) is completely contained within...". Page 69--The last blue box in Table 14 should read "Total system current". Current direction is irrelevant. Page 72--the Drafting Team should consider adding the word "Stable" in the lower right region of the Figure 16 graph, and the word "Unstable": under the words "Capability Curve" to the right of SSSL. Page 74--in Table 15, X'd was changed to X'd, but "sub-transient" was not corrected to read "saturated transient reactance". Page 75--regarding Table 16, define the Base that the values of Table 15 have been converted to (e.g. "Table 16. Example calculations (Generator) on 941 MVA base"). Pages 74-75--there are two different values for Ze and both are in ohms, not per unit. Page 75--in Equation (107)  $j0.3845 + j0.171 + 0.06796$  does is not equal to  $0.6239 \angle 90^\circ$ . Page 75-- Zsys is defined as  $0.6239 \angle 90^\circ \Omega$  in Equation (107) of Table 16, but defined as  $0.6234 \angle 90^\circ \Omega$  in Equation (109) of Table 16 and in Equation (110) of the Instantaneous Overcurrent Relay section. Page 78--in Figure 20 add "hashing" to the area between the SSSL (black) curve and the 40-1 (blue) curve with an arrow and note saying "Stable and can trip" or similar wording. There are inconsistencies in the use of "per unit" in the tables of the Applications Guidelines. In some instances per unit is used, and in other instances the ohmic value is given. There should be consistency in the Applications Guidelines and standard.

Individual

Jamison Cawley

Nebraska Public Power District

It is clear the drafting team has put a great amount of effort into this standard which is quite complex. This effort is appreciated. Comments for consideration: R2.2 states: Within 12 full calendar months of becoming aware of a generator, transformer, or transmission line BES Element that tripped in response to a stable or unstable power swing due to the operation of its protective relay(s), determine whether its load-responsive protective relay(s) applied to that BES Element meets the criteria in PRC-026-1 – Attachment B. R2.2 hinges on "becoming aware" which seems will be difficult to prove or audit. The drafting team felt that it is not needed to prove how an entity addresses "becoming aware" but the RSAW indicates that an auditor should "(R2) Interview an entity representative to understand the entity's process for identifying applicable load-responsive protective relays applied on the terminals of the BES Elements identified pursuant to Requirement R2, Parts 2.1 and 2.2". R2.2 seems to be a very vague and unpredictable part to R2. The standard would be much cleaner without 2.2. A trip on a stable power swing will most likely be a misoperation and will be addressed per other NERC standards (e.g. PRC-004, PRC-016). A trip on an unstable power swing may or may not be a misoperation depending on if the relaying was set to trip for OOS or not. It seems the only benefit to 2.2 then is to identify correct trips for unstable swings and this does not seem to add significant reliability compared to the burden and audit risks. Consider removal of 2.2. During the 11-13-2014 webinar some concerns were noted regarding the guidelines and technical basis equations and calculations. Since a significant portion of this document is devoted to calculations it is beneficial these be as accurate as possible since it will be a part of compliance. Any reevaluations and rechecks of these calculations are greatly appreciated. There is

concern with voting yes until the final checks can be made. In addition to these comments, we also support the comments submitted by SPP.
Individual
Brett Holland
Kansas City Power and Light
Attachment A The following protection functions should also be excluded from the Requirement of this standard: Phase distance relay elements that do not reach beyond the next bus. Loss-of-field relay elements that do not reach beyond the generator impedance.
Individual
Thomas Foltz
American Electric Power
Applicability, Section 4.2 (Facilities): Despite the changes proposed in this most recent draft, our interpretation is the same as it was for the previous version. That being the case, we're not certain the proposed changes are serving their intended purpose. Could the team provide some insight into what they were trying to clarify or correct with their most recent changes to this section? R2 and R2.1: Collectively, these requirements read awkwardly due to multiple uses of the word "determine". We suggest eliminating the first "determine", so that R2 instead reads "Each Generator Owner and Transmission Owner shall:".
Group
PacifiCorp
Sandra Shaffer
The drafting team should eliminate or revise criterion 3 under PRC-026-1 R1. PRC-006 studies are performed to help ensure sufficient load is available to be shed during extreme events to help arrest frequency decline within an island. Since there are a large number of potential but very low probability extreme events that could result in island formation, UFLS programs applied to small loads dispersed throughout the interconnected system in order to increase the likelihood that potential islands include load that can be shed. Since many of these potential islands and the elements that open to form them are highly speculative, R1 Criteria 3, if it is kept, should be modified to limit its application to elements associated with actual events or specifically designed island boundaries. The Planning Coordinator should not be required to develop a criteria for identifying islands.
Individual
Sonya Green-Sumpter
South carolina Electric & Gas
1) Please make R1, Criterion 3 clearer by replacing 'where' with 'only if'. It then reads " An Element that forms the boundary of an island in the most recent underfrequency load shedding UFLS) design assessment based on application of the Planning Coordinator's criteria for identifying islands, only if the island is formed by tripping the Element due to angular instability." 2) Please expand Application Guidelines p20 explanation of Criterion 3 by adding, 'PC area boundary tie lines, or BA boundary tie lines' at the end of the last sentence so that it reads "The criterion does not apply to islands identified based on other considerations that do not involve angular instability, such as excessive loading, PC area boundary tie lines, or BA boundary tie lines." 3) R1 Criteria 3 and 4, and R2 2.2 identify BES Elements tripped for instability. The Standard's Purpose is 'To ensure that load-responsive protective relays are expected to not trip in response to stable power swings during non-Fault conditions.' (Why do relays that trip on instability need to be evaluated and required to meet this standard?) Please explain that these BES Elements are included because they could be more likely to be challenged by power swings. Their inclusion does not mean that the relays tripping these Elements were necessarily inappropriate. Such an explanation could fit well on page 18 just after "The first step uses criteria to identify the Elements on which a Protection System is expected to be challenged by power swings."
Individual
Amy Casuscelli
Xcel Energy

Although the latest draft of PRC-026 is an improvement, Xcel Energy feels that there are additional opportunities for improvement. We respectfully submit the following comments for the drafting team's consideration. A new Requirement should be added requiring the PC to provide the system separation angle as part of the notification in order to ensure proper calculation of relay settings. Suggested wording: [Each Planning Coordinator shall provide notification of the system separation angle of each identified BES Element(s) in its area that met any of the Criteria in R1, if any, to the respective Generator Owner and Transmission Owner.] Additionally, the 1.05 V Pu voltage is subjective and not based on a study, and contradicts what the GTB says about the AVR: "it is more likely that the relay would operate during a power swing when the automatic voltage regulator (AVR) is in manual mode rather than when in automatic mode." The statement would lead one to believe that 1- The GO is operating in manual mode in contrast to the VAR standards. 2 – That operating in manual mode would keep the unit voltage at 1.05 pu, which is inherently false. Therefore, the calculations in GTB are hypothetical and should not be in a standard, as they provide no reliability assurance.

Individual

Michael Moltane

ITC

Edit R2.2 to include, "...due to the operation of its protective [functions described in Attachment A], determine..." Modern relays which enable power swing blocking functions result in time-delayed clearing for subsequent 3 phase faults. E.g. SEL-411L manual states "Three-phase faults will be detected with a minimum and maximum time delay of two and five cycles, respectively." More conventional power swing blocking functions result in time delays much longer than 5 cycles, possibly exceeding 1 second. Does the SDT believe this is "dependable fault detection"? Does the SDT believe this contributes to the reliability of the BES? Edit page 79, "Double blinder schemes are more complex [than] the single..." R1 Criteria 3 remains unclear. PRC-006 does not seem to require the level of detail required for PCs to meet this requirement. Our concerns are that PCs will commit much more resources to developing this level of detail or absent that level of detail will identify all or none of the boundary elements as meeting this criteria.

Group

ISO RTO Council Standards Review Committee

Greg Campoli

The IRC SRC appreciates the drafting team's efforts in addressing industry concerns, especially those we submitted in the prior posting. We believe our concerns have been addressed, but respectfully suggest the following small clarification regarding Requirement R3: Each Generator Owner and Transmission Owner shall, within six full calendar months of determining, pursuant to R2, that a load-responsive protective relay does not meet the PRC-026-1 – Attachment B criteria, develop a Corrective Action Plan (CAP) to meet one or more of the following... Thank you for the additional comment opportunity.

Individual

Steve

Rueckert

I don't have any concerns with the standard as drafted. However, you may wish to make a grammatical review of the language of R2. the word "determine" is included in the language of R2 (last word) as well as in Parts 2.1 and 2.2. It seems like it is not needed both times.

Group

SERC Protection and Controls Subcommittee

David Greene

1) Please make R1, Criterion 3 clearer by replacing 'where' with 'only if'. It then reads " An Element that forms the boundary of an island in the most recent underfrequency load shedding (UFLS) design assessment based on application of the Planning Coordinator's criteria for identifying islands, only if the island is formed by tripping the Element due to angular instability." 2) Please expand Application Guidelines p20 explanation of Criterion 3 by adding, 'PC area boundary tie lines, or BA boundary tie lines' at the end of the last sentence so that it reads "The criterion does not apply to islands identified based on other considerations that do not involve angular instability, such as excessive loading, PC area boundary tie lines, or BA boundary tie lines." 3) R1 Criteria 3 and 4, and

R2 2.2 identify BES Elements tripped for instability. The Standard's Purpose is 'To ensure that load-responsive protective relays are expected to not trip in response to stable power swings during non-Fault conditions.' (Why do relays that trip on instability need to be evaluated and required to meet this standard?) Please explain that these BES Elements are included because they could be more likely to be challenged by power swings. Their inclusion does not mean that the relays tripping these Elements were necessarily inappropriate. Such an explanation could fit well on page 18 just after "The first step uses criteria to identify the Elements on which a Protection System is expected to be challenged by power swings." The comments expressed herein represent a consensus of the views of the above-named members of the SERC EC Protection and Control Subcommittee only and should not be construed as the position of SERC Reliability Corporation, its board, or its officers.

Individual

Sergio Banuelos

Tri-State Generation and Transmission Association, Inc.

Tri-State believes that Requirement R3 should continue to refer to the Requirement to assess the load-responsive protective relays against the criteria of PRC-026-1 - Attachment B. We recommend adding "pursuant to Requirement R2," between "PRC-026-1 - Attachment B criteria," and "develop a Corrective Action Plan (CAP)" in Requirement R3. Without the clarifying clause, the requirement could be referring to any load-responsive protective relay that the entity happens to recognize that does not meet the criteria in the attachment.

Group

Dominion

Connie Lowe

As mentioned in the Webinar, the upper loss of synchronism circle is based on the ratio of sending-end to receiving-end voltage of 1.43. Looking at the REDLINE copy of PRC-026-1 draft 3, this should be revised in several places, Revisions Page 19 of 98: " [...] (2) an upper loss-of-synchronism circle based on a ratio of the sending-end to receiving-end voltages of 1.43" Page 31 of 98: "The second shape is an upper loss of synchronism circle based on a ratio of the sending-end to receiving-end voltage of 1.43 (i.e.,  $ES / ER = 1.0 / 0.7 = 1.43$ )." Page 32 of 98: "Eq. (3):  $E_S/E_R = 1.0/0.7=1.43$ " Page 37 of 98: "Shape 2 – Upper Loss of Synchronism Circle With Sending to Receiving Voltage Ratio of 1.43" Page 72 of 98: Table 13 should have an example calculation where  $ES < ER$  for the lower loss of synchronism circle and an example calculation where  $ES > ER$  for the upper loss of synchronism circle. As discussed with Kevin Jones at Xcel Energy, a revision of Figure 5, on page 41 of 98, changing "Voltage (p.u.)" to the voltage ratio of "ES/ER", where the ratio extends from 0.7 to 1.43, would align nicely with the edits above.

Group

SPP Standards Review Group

Shannon Mickens

We have a concern about the significance of Attachment A in the documentation and ask the drafting team to provide more clarity on this documentation. In Requirement R3, the drafting team mentions that the Generator Owner and Transmission Owner has six full calendar months after determining that load-responsive protection relays don't meet Attachment B criteria and a Correction Action Plan (CAP) needs to be developed. Additionally in the second bullet of the same requirement, the drafting team mentions 'The Protection System is excluded under the PRC-026-1 – Attachment A criteria'. However in the Rationale Box of R3, the drafting team provides detailed information on the necessity of the CAP and its association with Attachment B. As for Attachment A, there is no explanation of how it impacts the Generator Owner and Transmission Owner or what role it plays in this process. Please provide more detailed information in the Rationale Box of R3 in reference to Attachment A.

Group

Duke Energy

Michael Lowman

"Duke Energy would like to reiterate that we do not believe adequate technical justification has been identified for this project to become a standard. Based on the SPCS recommendation, the SDT and NERC should consider moving this project to a Guideline document until such time as a standard is warranted."

Group
PPL NERC Registered Affiliates
Brent Ingebrigtsen
These comments are submitted on behalf of the following PPL NERC Registered Affiliates: LG&E and KU Energy, LLC; PPL Electric Utilities Corporation, PPL EnergyPlus, LLC; PPL Generation, LLC; PPL Susquehanna, LLC; and PPL Montana, LLC. The PPL NERC Registered Affiliates are registered in six regions (MRO, NPCC, RFC, SERC, SPP, and WECC) for one or more of the following NERC functions: BA, DP, GO, GOP, IA, LSE, PA, PSE, RP, TO, TOP, TP, and TSP. Comments: We agree that SDT has largely addressed industry comments on this standard and believe that STD's work on this standard sets a model for future collaborative effort. We have only one remaining concern. Although the Application Guideline has language that satisfactorily explains the intent of the "becoming aware of" language in subpart 2.2, we are concerned that a guideline is not enforceable. We recommend adding a footnote in subpart 2.2 that solidly ties the guideline language to this subpart. If this single change were made to this version of the standard, PPL would vote affirmatively
Individual
Muhammed Ali
Hydro One
Group
JEA
Thomas McElhinney
We are concerned that this standard may have unintended consequences and hurt the reliability of the BES.
Group
ACES Standards Collaborators
Jason Marshall
(1) The drafting team has continued improving this standard and we thank you for the improvements. (2) We question the need for this standard. In its "Protection System Response to Power Swings" (on page 5) document dated August 2013, the NERC System Protection and Control Subcommittee (SPCS) concluded "that a NERC Reliability Standard to address relay performance during stable power swings is NOT needed, and could result in unintended adverse impacts to the Bulk-Power System reliability" [emphasis added]. (3) The footnote in criterion 2 for Requirement R1 is technically inaccurate and should be modified. An Element would be identified through the application of the PC's SOL methodology which is required in FAC-014-2 not FAC-010. The methodology must be developed in FAC-010 but application is required in FAC-014-2 R3 and R4. (3) Why is the word "full" added to "six full calendar months"? We think it only adds confusion in other areas where it is not included. The words six calendar months imply the inclusion of a "full" calendar month. (4) Requirement R4 should be modified to avoid a registered entity being in technical violation for simply updating their Corrective Action Plan (CAP). As it is written, the applicable entity must both implement the CAP and update the CAP. The problem is that they may be updating the CAP because implementation on the original timeline is not possible. As R4 is written with an "and" condition, this is not possible without a technical violation of the requirement. We suggest changing the second "and" to "or" to address this concern. (5) Criterion 4 of Requirement R1 requires further explanation. In response to our previous comment questioning the inclusion of unstable power swings in criterion 4 of Requirement R1, the drafting team stated that "this standard does not require that entities assess Protection System performance during unstable swings." If this is the case, this would support removing "unstable power swings" from criterion 4. What reliability purpose does the PC notifying the GO and TO of Elements susceptible to unstable power swings serve, if the GO and TO are not required to do anything with the information. (6) Any VRFs that are greater than Lower would seem to be inconsistent with the recommendation of the SPCS (see our point two for the recommendation) that a standard is not needed. Especially, assigning Requirement R2 a VRF of High would seem to a complete rejection of this recommendation. Is this what is intended by the drafting team? (7) Should Requirement R3 allow selection of "one or more of the following" or should it be limited to selecting one option? In other words, can a Protection System meet both Criteria A and B simultaneously? If not, then "one or more of the following" should be changed to "either of the following." (8) We do not understand why unstable power swings are included in Part



2.2. Per the purpose statement of the standard and the drafting's prior response to comments (see our bullet 5), the purpose is to prevent tripping of protective relays in response to stable power swings. It is not intended to prevent tripping due to unstable power swings. Thus, why would Part 2.2 compel an evaluation of load-responsive relays for actual tripping due to unstable power swings?  
(8) Thank you for the opportunity to comment.

Group

DTE Electric Co.

Kathleen Black

Agree with PSEG comments. The current draft does provide more detailed evaluation basis and examples, however, not all variations in protection schemes are addressed which could result in misapplication of the evaluation criteria.

Group

Tennessee Valley Authority

Dennis Chastain

Based on the proposed implementation plan, it seems that the applicable GO and TO will not be required to perform an initial R2.1 evaluation until the second annual notification is received from the PC. Suggest making the "12 months" in the R1 implementation statement "24 months" unless a practice year was intended for the PC requirement. Consider making the implementation date for R3 and R4 lag the implementation date of R2 by six months. The R3 requirement allows for six months to develop a CAP following completion of work associated with R2. To align with the change made to requirement R2 regarding evaluations performed in the last five calendar years, consider making the effective date of R2 the "First day of the first full calendar year that is 60 months after the date..." Page number references in the following comments apply to the redline posting. Page 19: Within the "Rationale for Attachment B (Criteria A)" box shaded blue, should "... varying from 0.7 to 1.0 per unit..." be changed to "varying from 0.0 to 1.0 per unit..." to match the change made in the preceding Criteria A section? Page 24: In the Requirement R1 section, recommend replacing the last sentence with "It is possible that a Planning Coordinator will utilize prior year studies in determining their requirement R1 Elements list each year." Page 25: In the Requirement R1, Criterion 1 section, suggest changing "The 66 kV transmission line is not electrically joined to the 345 kV and 230 kV transmission lines at the plant site and is not a part of the operating limit or RAS." to "The 66 kV transmission lines are not electrically joined to the 345 kV and 230 kV transmission lines at the plant site and are not a part of the operating limit or RAS." since there is more than one 66 kV line in the example. Page 25: In the Requirement R1, Criterion 2 section, since the acronym SOL is now spelled out in the Criterion 1 section, the acronym can be used in the Criterion 2 section without spelling it out.

Individual

Anthony Jablonski

ReliabilityFirst

ReliabilityFirst votes in the Affirmative and believes the PRC-026-1 standard enhances reliability and ensures that load-responsive protective relays are expected to not trip in response to stable power swings during non-Fault conditions. ReliabilityFirst offers the following comments for consideration:  
1. Requirement R2 – the language regarding who determines whether or not a stable or unstable power swing has occurred is vague. The associated application notes state that the SDT purposefully avoided making the GO or TO responsible for that determination and allude that possibly the GO or TO, the RE or NERC during an event analysis could be the source. Unfortunately, this wording sets up a lot of finger pointing as to who was responsible to launch the analysis of the compliance of PRC-026 with the event. ReliabilityFirst recommends including language clearly identifying the source of who determines whether or not a stable or unstable power swing has occurred as referenced in Requirement R2.

Individual

Richard Vine

California ISO

The California ISO does not agree with the change to remove the Transmission Planner in the Applicability section and in Requirement R1. The California ISO supports continuing to include the Transmission Planner in Requirement R1 as suggested by the PSRPS Report.

Individual
Spencer Tacke
Modesto Irrigation District
The standard should be applicable to more than just BES elements. I think it is critical that the following phrase be included in Part 4.2 of the Applicability Section: "Any system element, regardless of size or connected voltage, that has been shown to be material to the reliability of the BES". The "bright line" of 100 kV is fine in general, but when it is known that an element connected at less than 100 kV is material to the reliability of the BES, it should be included as an applicable facility for this standard. This is because WECC members have learned over the years to recognize the significant role that smaller size elements play in system response and stability. Also, past WECC studies of major outages have shown that elements connected at less than 100 kV, have played a major role in the impact of outages. In fact, the most accurate duplication of the 1996 major system wide outage and more recent outages that the WECC MVWG has simulated, have shown that the accuracy of the simulated results of actual system outages is highly affected by the accuracy of the modeled system below 100 KV.
Individual
Scott Berry
Indiana Municipal Power Agency
Individual
John Brockhan
CenterPoint Energy Houston Electric, LLC
(1) CenterPoint Energy still feels strongly that there is redundancy between PRC-004 and PRC-026 regarding Corrective Action Plans (CAPs) and must again vote negative. Redundancy is included in the NERC Paragraph 81 (P.81) project as item "B7. Redundant". Item "B7. Redundant" states the following: "The Reliability Standard requirement is redundant with: (i) another FERC-approved Reliability Standard requirement(s); (ii) the ERO compliance and monitoring program or (iii) a governmental regulation (e.g., Open Access Transmission Tariff, North American Energy Standards Board ("NAESB"), etc.). This criterion is designed to identify requirements that are redundant with other requirements and are, therefore, unnecessary. Unlike the other criteria listed in Criterion B, in the case of redundancy, the task or activity itself may contribute to a reliable BES, but it is not necessary to have two duplicative requirements on the same or similar task or activity. Such requirements can be removed with little or no effect on reliability and removal will result in an increase in efficiency of the ERO compliance program." Based on our understanding, from responses to comments and also from the recent Q&A webinar, the SDT believes that PRC-026 is more stringent than PRC-004; therefore, PRC-026 requirements for a CAP would supersede those in PRC-004. Mainly, PRC-026 will require a CAP, whereas PRC-004 does not require a CAP if explained "in a declaration why corrective actions are beyond the entity's control or would not improve BES reliability, and that no further corrective actions will be taken." We believe such duplicative requirements could send mixed signals where a CAP does not appear to be required (PRC-004) when, in fact, one is required (PRC-026). Should standard PRC-026 be approved as currently written, CenterPoint Energy recommends, due to redundancy, that NERC initiate a project to remove the requirement for a CAP for Protection System operations from power swings in standard PRC-004. (2) CenterPoint Energy technically disagrees with the SDT's response that operator-initiated switching to reconnect islands, to restore load during Black Start activities, or to synchronize a generating unit to the system should be applicable to PRC-026. We believe that any Element that tripped in response to a stable or unstable power swing involving restoration and black-starting would be addressed in after-action reviews of those events. We expect that entities will need to coordinate with their Regional Entities to address such circumstances.
Group
BC Hydro
Patricia Robertson
BC hydro does not agree with the proposed new reliability standard PRC-026-1. In the past 15 years with approximately 1000 faults per year on the transmission system, there has not been a single undesired protection operation on a stable power swing. There have been some protection operations on power swings, but they were desirable, and separated systems that were about to go

out of step. BC Hydro has a very large portion of its transmission system that is subject to stability constraints. Therefore, even the focussed approach proposed in the new standard will present a significant amount of engineering resources to perform the stability checks and protection response checks to determine whether setting modifications or addition of power swing blocking relays or whether exemptions are required. BC Hydro recommends that the new standard not be implemented, or if it is implemented, that the WECC region be exempted in view of the fact that the transmission network is sparse, with many stability constraints. The work required to meet this standard will be excessive, even with the focussed approach proposed.

Group

Seattle City Light

Paul Haase

Seattle City Light appreciates the efforts of the Standards Drafting Team to respond to comments and clarify the proposed draft. Seattle, however, continues to believe that the proposed Standard is not warranted by the history of major electrical outages. Seattle further finds the proposed Standard to be based on theoretical concepts rather than practical experience, and as such, proposes a largely untried process to become a rigid federal regulation having continental reach. Recent industry experience suggests the difficulty of such an approach. Consider industry experience with another new concept, that of the NERC "Order 754" effort. Considerable back-and-forth exchange and flexibility was required of this effort before well-meaning entities across the continent--each having different configurations, equipment, and characteristics--were able to apply a new, untried process to reach a desired and consistent result. Furthermore, as the drafting team will recall, the Order 754 request required some three years to complete, and first year was spent almost entirely in clarifications and modifications. The clarifications and modifications were necessary to address the differing equipment and configurations of diverse entities, configurations and equipment that had not been considered by the team that framed the request. Matters came up as fundamental as "what is meant by the term 'bus' in the request?" (in the end, 'bus' was defined to mean one thing for one part of the request and defined as something else for another part). Given the diversity of entities in North America, how could any team, no matter how strong, be expected to conceive of all possible arrangements with no application experience to guide them? Consider now that the proposed Standard is just as untried as the Order 754 request and is rather more complex. Moreover, as a mandatory reliability Standard it would lack the implementation flexibility that allowed successful completion of the Order 754 request. Consequently Seattle is deeply concerned about the effectiveness of the proposed approach in improving the reliability of the bulk electric system in the near term. Rather it appears more likely to drive a bow-wave of compliance violations as numerous entities struggle to apply new theoretical processes that do not fit their situation and circumstances, and regulators struggle to figure out how to audit a misfit Standard. As such, Seattle votes Negative on this ballot and expects to do so in future ballots as well. Seattle would consider an Affirmative position if the draft Standard was put on hold and a 1-2 year pilot program run in its place. Such a pilot program could be structured as a mandatory reporting exercise somewhat like the Order 754 effort: reporting would be required but results would not be audited for compliance (rather used for learning). Alternatively, a pilot program might be structured to focus on a small number of entities such as the recent CIP v5 pilot program (with the difference that no PRC-026-1 Standard would be adopted, until after the pilot when lessons learned could be incorporated into it). Once experience had been acquired with the real-world application of the proposed PRC-026-1 requirements, and the Standard revised to accommodate these lessons, then Seattle would consider an Affirmative vote. Should a pilot program be implemented, Seattle would be willing to serve a test entity.

Group

Bonneville Power Administration

Andrea Jessup

BPA has no unresolved issues.

Group

Associated Electric Cooperative, Inc.

Phil Hart

AECEI believes that the term unstable power swing should be removed from this standard. Reliability risks associated with unstable swings are already handled with relay protection (PRC) and system study standards (TPL). FERC ordered this drafting team to address issues associated with stable

power swings, and the addition of unstable swings in the language is unwarranted. In the previous round of commenting the SDT responded by stating this inclusion was inherent in statements made in the PSRPS report. I would encourage the SDT to also read the following statement from page 19 of that same report, "over-emphasizing secure operation for stable powers swings could be detrimental to Bulk-Power System reliability." By including unstable power swings within the screening process of R1 more events will qualify for testing and the SDT will have done the very thing the SPCS warned against. An unwarranted emphasis on stable power swings is created when you use unrelated events like unstable swings to define your testing criteria for stable swings. AECI would respectfully request the drafting team removed "unstable" from PRC-026 and keep stable and unstable power swing standards as completely separate as possible, or provide the reliability based risk that exists without the inclusion of this term within the standard.

Group

Bureau of Reclamation

Erika Doot

The Bureau of Reclamation (Reclamation) supports the proposed PRC-026-1. Reclamation appreciates the drafting team's efforts revising the Applicability, Requirements, and Measures to clarify which entities will be required to complete stable power swing analysis for which qualifying facilities and elements.

**Additional Comments:**

**Xcel Energy**  
**Amy Casuscelli**

The reference to FAC-10 in R1 Criterion 2 does not appear to be consistent with its intent since the Planning Coordinator's methodology per se does not identify/establish the SOLs... instead, they are determined based on applying the methodology, which is required in FAC-014-2. Therefore, assuming there is value in retaining a reference in Criterion 2, it should probably be changed to R3 of FAC-014 that requires SOLs to be established by the Planning Coordinator. Or the reference could be changed to R6 of FAC-014, which specifically pertains to identifying the stability limit SOLs. However, it may be sufficient to have no reference in Criterion 2 as follows: "Monitored elements that are part of (angular) stability limit SOLs determined by the Planning Coordinator."

**END OF REPORT**

# Consideration of Comments

## Project 2010-13.3 Phase 3 of Relay Loadability: Stable Power Swings

The Project 2010-13.3 Drafting Team thanks all commenters who submitted comments on the standard. These standards were posted for a 21-day public comment period from November 4, 2014 through November 24, 2014. Stakeholders were asked to provide feedback on the standards and associated documents through a special electronic comment form. There were 42 sets of comments, including comments from approximately 142 different people from approximately 88 companies representing all 10 Industry Segments as shown in the table on the following pages.

All comments submitted may be reviewed in their original format on the standard's [project page](#).

If you feel that your comment has been overlooked, please let us know immediately. Our goal is to give every comment serious consideration in this process. If you feel there has been an error or omission, you can contact the Director of Standards, Valerie Agnew, at 404-446-2566 or at [valerie.agnew@nerc.net](mailto:valerie.agnew@nerc.net). In addition, there is a NERC Reliability Standards Appeals Process.<sup>1</sup>

## Summary of Changes to the Standard

The following is a summary of the revisions to Draft 4 that were made to the proposed PRC-026-1 NERC Reliability Standard in order to provide additional clarity of the Standard. Revisions were based on industry stakeholder comments from Draft 3 of the Standard.

### Applicability

- No change

### Background

- The Background section was updated for clarity

### Effective Dates

- No change

### Requirement R1

- Minor editorial revisions based upon comments
- Footnote added to draw attention to new detail provided in the Guidelines and Technical Basis concerning the inclusion of “unstable” in Criterion 4

<sup>1</sup> The appeals process is in the Standard Processes Manual: [http://www.nerc.com/comm/SC/Documents/Appendix\\_3A\\_StandardsProcessesManual.pdf](http://www.nerc.com/comm/SC/Documents/Appendix_3A_StandardsProcessesManual.pdf)

**Requirements R2**

- The word “determine” was removed from the main requirement body based on comments as it is duplicative of Parts 2.1 and 2.2
- Footnote added to draw attention to examples provided in the Guidelines and Technical Basis of how an entity would “become aware” of a stable or unstable power swing
- Footnote added to draw attention to new detail provided in the Guidelines and Technical Basis concerning the inclusion of “unstable” in Part 2.2
- The rationale box text was updated for clarity

**Requirement R3**

- The phrase “pursuant to Requirement R2” was inserted based on comments to provide a referential link to the previous requirement which triggers performance under Requirement R3
- The clause “or more” was deleted based on comments to remove confusion about whether either or both of the Corrective Action Plan options were required. Although an entity may perform both under certain circumstances, the standard drafting team concluded that performing one of the two bulleted items would achieve the reliability goal of the standard
- The rationale box text was updated for clarity

**Requirement R4**

- No change

**Measures M1-M4**

- No change

**Compliance Section**

- No change

**Violation Severity Levels**

- No change

**PRC-026-1 – Attachment A**

- The phrase “provided the distance element is set in accordance with the criteria outlined in the standard” has been removed from a bullet in the PRC-026-1 – Attachment A (protection system functions that are excluded from the standard) pertaining to phase fault detector relay elements that supervise other load-responsive phase distance elements. The removal of the phrase does not change any performance under requirements of the standard, however, it does eliminate any inadvertent confusion that may be introduced by this phrase. Phase distance elements are on the PRC-026-1 – Attachment A inclusion list and must be set in accordance with PRC-026-1 – Attachment B, Criterion A if the protected Element (i.e., transmission line,

transformer, or generator BES Element) is determined to be applicable to the standard pursuant to Requirement R1 and/or Requirement R2. Given that:

1. the pickup of the phase fault detector relay element cannot cause a trip without the pickup of the supervised phase distance element, and
2. the phase distance relay element must be set in accordance with PRC-026-1 – Attachment B, Criterion A, the deleted phrase is irrelevant and unnecessary

#### **PRC-026-1 – Attachment B**

- The uses of “Criteria” were replaced by “Criterion” for correctness
- The order of “sending-end” to “receiving-end” voltages were reversed and swapped for correctness

#### **Guidelines and Technical Basis**

- The Guidelines and Technical Basis received a number of varying revisions to provide additional clarity. Some of the most notable enhancements include:
- Several Figures were corrected due to errors reported through the comments
- Several calculations in the Tables were corrected due to errors reported through the comments, Table 13 in particular
- Several revisions were due to inconsistencies within the document on how information is presented
- The format of the document was updated for consistency with the NERC style guide
- The section, “Justification for Including Unstable Power Swings in the Requirements” was appended to provide an understanding of why “unstable” power swings are relevant to the performance of the Standard.

#### **Implementation Plan**

- Clarification to the section, “Notifications Prior to the Effective Date of Requirement R2” was made to clarify an entity’s obligations during the implementation plan period

#### **VRF and VSL Justifications**

- Several paragraphs that were redundant with other information were removed
- Minor corrections made in the text

- 1. The Protection System Response to Power Swings Standard Drafting Team believes it has addressed industry comments in such a manner that industry consensus can be achieved. If there are remaining unresolved issues in the proposed PRC-026-1 Reliability Standard, please provide your comments here: .....13**



**The Industry Segments are:**

- 1 — Transmission Owners
- 2 — RTOs, ISOs
- 3 — Load-serving Entities
- 4 — Transmission-dependent Utilities
- 5 — Electric Generators
- 6 — Electricity Brokers, Aggregators, and Marketers
- 7 — Large Electricity End Users
- 8 — Small Electricity End Users
- 9 — Federal, State, Provincial Regulatory or other Government Entities
- 10 — Regional Reliability Organizations, Regional Entities

Group/Individual		Commenter	Organization	Registered Ballot Body Segment										
				1	2	3	4	5	6	7	8	9	10	
1.	Group	Joe DePoorter	MRO NERC Standards Review Forum		X	X	X	X	X					
	<b>Additional Member</b>	<b>Additional Organization</b>	<b>Region</b>	<b>Segment Selection</b>										
1.	Amy Casucelli	Xcel Energy	MRO	1, 3, 5, 6										
2.	Chuck Wicklund	Otter Tail Power	MRO	1, 3, 5										
3.	Dan Inman	Minnkota Power Cooperative	MRO	1, 3, 5, 6										
4.	Dave Rudolph	Basin Electric Power Coop	MRO	1, 3, 5, 6										
5.	Kayleigh Wilkerson	Lincoln Electric System	MRO	1, 3, 5, 6										
6.	Jodi Jensen	WAPA	MRO	1, 6										
7.	Ken Goldsmith	Alliant Energy	MRO	4										
8.	Mahmood Safi	Omaha Public Power District	MRO	1, 3, 5, 6										
9.	Marie Knox	MISO	MRO	2										
10.	Mike Brytowski	Great River Energy	MRO	1, 3, 5, 6										
11.	Randi Nyholm	Minnesota Power	MRO	1, 5										
12.	Scott Nickels	Rochester Public Utilities	MRO	4										
13.	Terry Harbour	MidAmerican Energy	MRO	1, 3, 5, 6										
14.	Tom Breene	Wisconsin Public Service	MRO	3, 4, 5, 6										

Group/Individual	Commenter	Organization	Registered Ballot Body Segment																																																																																																													
			1	2	3	4	5	6	7	8	9	10																																																																																																				
15. Tony Eddleman	Nebraska Public Power District	MRO	1, 3, 5																																																																																																													
2.	Group	Guy Zito	Northeast Power Coordinating Council																	X																																																																																												
<table border="1"> <thead> <tr> <th>Additional Member</th> <th>Additional Organization</th> <th>Region</th> <th>Segment Selection</th> </tr> </thead> <tbody> <tr><td>1. Alan Adamson</td><td>New York State Reliability Council, LLC</td><td>NPCC</td><td>10</td></tr> <tr><td>2. David Burke</td><td>Orange and Rockland Utilities Inc.</td><td>NPCC</td><td>3</td></tr> <tr><td>3. Greg Campoli</td><td>New York Independent System Operator</td><td>NPCC</td><td>2</td></tr> <tr><td>4. Sylvain Clermont</td><td>Hydro-Quebec TransEnergie</td><td>NPCC</td><td>1</td></tr> <tr><td>5. Kelly Dash</td><td>Consolidated Edison Co. of New York Inc.</td><td>NPCC</td><td>1</td></tr> <tr><td>6. Gerry Dunbar</td><td>Northeast Power Coordinating Council</td><td>NPCC</td><td>10</td></tr> <tr><td>7. Milke Garton</td><td>Dominion Resources Services, Inc.</td><td>NPCC</td><td>5</td></tr> <tr><td>8. Kathleen Goodman</td><td>ISO - New England</td><td>NPCC</td><td>2</td></tr> <tr><td>9. Ben Wu</td><td>Orange and Rockland Utilities Inc.</td><td>NPCC</td><td>1</td></tr> <tr><td>10. Mark Kenny</td><td>Northeast Utilities</td><td>NPCC</td><td>1</td></tr> <tr><td>11. Helen Lainis</td><td>Independent Electricity System Operator</td><td>NPCC</td><td>2</td></tr> <tr><td>12. Alan MacNaughton</td><td>New Brunswick Power Corporation</td><td>NPCC</td><td>9</td></tr> <tr><td>13. Bruce Metruck</td><td>New York Power Authority</td><td>NPCC</td><td>6</td></tr> <tr><td>14. Silvia Parada Mitchell</td><td>NextEra Energy, LLC</td><td>NPCC</td><td>5</td></tr> <tr><td>15. Lee Pedowicz</td><td>Northeast Power Coordinating Council</td><td>NPCC</td><td></td></tr> <tr><td>16. Robert Pellegrini</td><td>The United Illuminating Company</td><td>NPCC</td><td>1</td></tr> <tr><td>17. Si Truc Phan</td><td>Hydro-Quebec TransEnergie</td><td>NPCC</td><td>1</td></tr> <tr><td>18. David Ramkalawan</td><td>Ontario Power Generation, Inc.</td><td>NPCC</td><td>5</td></tr> <tr><td>19. Brian Robinson</td><td>Utility Services</td><td>NPCC</td><td>8</td></tr> <tr><td>20. Ayesha Sabouba</td><td>Hydro One Networks Inc.</td><td>NPCC</td><td>1</td></tr> <tr><td>21. Peter Yost</td><td>Consolidated Edison Co. of New York, Inc.</td><td>NPCC</td><td>3</td></tr> <tr><td>22. Wayne Sipperly</td><td>New York Power Authority</td><td>NPCC</td><td>5</td></tr> </tbody> </table>																					Additional Member	Additional Organization	Region	Segment Selection	1. Alan Adamson	New York State Reliability Council, LLC	NPCC	10	2. David Burke	Orange and Rockland Utilities Inc.	NPCC	3	3. Greg Campoli	New York Independent System Operator	NPCC	2	4. Sylvain Clermont	Hydro-Quebec TransEnergie	NPCC	1	5. Kelly Dash	Consolidated Edison Co. of New York Inc.	NPCC	1	6. Gerry Dunbar	Northeast Power Coordinating Council	NPCC	10	7. Milke Garton	Dominion Resources Services, Inc.	NPCC	5	8. Kathleen Goodman	ISO - New England	NPCC	2	9. Ben Wu	Orange and Rockland Utilities Inc.	NPCC	1	10. Mark Kenny	Northeast Utilities	NPCC	1	11. Helen Lainis	Independent Electricity System Operator	NPCC	2	12. Alan MacNaughton	New Brunswick Power Corporation	NPCC	9	13. Bruce Metruck	New York Power Authority	NPCC	6	14. Silvia Parada Mitchell	NextEra Energy, LLC	NPCC	5	15. Lee Pedowicz	Northeast Power Coordinating Council	NPCC		16. Robert Pellegrini	The United Illuminating Company	NPCC	1	17. Si Truc Phan	Hydro-Quebec TransEnergie	NPCC	1	18. David Ramkalawan	Ontario Power Generation, Inc.	NPCC	5	19. Brian Robinson	Utility Services	NPCC	8	20. Ayesha Sabouba	Hydro One Networks Inc.	NPCC	1	21. Peter Yost	Consolidated Edison Co. of New York, Inc.	NPCC	3	22. Wayne Sipperly	New York Power Authority	NPCC	5
Additional Member	Additional Organization	Region	Segment Selection																																																																																																													
1. Alan Adamson	New York State Reliability Council, LLC	NPCC	10																																																																																																													
2. David Burke	Orange and Rockland Utilities Inc.	NPCC	3																																																																																																													
3. Greg Campoli	New York Independent System Operator	NPCC	2																																																																																																													
4. Sylvain Clermont	Hydro-Quebec TransEnergie	NPCC	1																																																																																																													
5. Kelly Dash	Consolidated Edison Co. of New York Inc.	NPCC	1																																																																																																													
6. Gerry Dunbar	Northeast Power Coordinating Council	NPCC	10																																																																																																													
7. Milke Garton	Dominion Resources Services, Inc.	NPCC	5																																																																																																													
8. Kathleen Goodman	ISO - New England	NPCC	2																																																																																																													
9. Ben Wu	Orange and Rockland Utilities Inc.	NPCC	1																																																																																																													
10. Mark Kenny	Northeast Utilities	NPCC	1																																																																																																													
11. Helen Lainis	Independent Electricity System Operator	NPCC	2																																																																																																													
12. Alan MacNaughton	New Brunswick Power Corporation	NPCC	9																																																																																																													
13. Bruce Metruck	New York Power Authority	NPCC	6																																																																																																													
14. Silvia Parada Mitchell	NextEra Energy, LLC	NPCC	5																																																																																																													
15. Lee Pedowicz	Northeast Power Coordinating Council	NPCC																																																																																																														
16. Robert Pellegrini	The United Illuminating Company	NPCC	1																																																																																																													
17. Si Truc Phan	Hydro-Quebec TransEnergie	NPCC	1																																																																																																													
18. David Ramkalawan	Ontario Power Generation, Inc.	NPCC	5																																																																																																													
19. Brian Robinson	Utility Services	NPCC	8																																																																																																													
20. Ayesha Sabouba	Hydro One Networks Inc.	NPCC	1																																																																																																													
21. Peter Yost	Consolidated Edison Co. of New York, Inc.	NPCC	3																																																																																																													
22. Wayne Sipperly	New York Power Authority	NPCC	5																																																																																																													
3.	Group	Sandra Shaffer	PacifiCorp																	X																																																																																												
N/A																																																																																																																
4.	Group	Greg Campoli	ISO RTO Council Standards Review Committee																	X																																																																																												
<table border="1"> <thead> <tr> <th>Additional Member</th> <th>Additional Organization</th> <th>Region</th> <th>Segment Selection</th> </tr> </thead> <tbody> <tr><td>1. Charles Yeung</td><td>SPP</td><td>SPP</td><td>2</td></tr> </tbody> </table>																					Additional Member	Additional Organization	Region	Segment Selection	1. Charles Yeung	SPP	SPP	2																																																																																				
Additional Member	Additional Organization	Region	Segment Selection																																																																																																													
1. Charles Yeung	SPP	SPP	2																																																																																																													

Group/Individual	Commenter	Organization	Registered Ballot Body Segment																	
			1	2	3	4	5	6	7	8	9	10								
2. Ben Li	IESO	NPCC	2																	
3. Matt Goldberg	ISONE	NPCC	2																	
4. Lori Spence	MISO	MRO	2																	
5. Cheryl Moseley	ERCOT	ERCOT	2																	
6. Mark Holman	PJM	RFC	2																	
5.	Group	David Greene	SERC Protection and Controls Subcommittee																	
<b>Additional Member Additional Organization Region Segment Selection</b>																				
1.	Paul Nauert	Ameran																		
2.	Russ Evans	SCE&G																		
3.	Phil Winston	Southern Company Services																		
4.	David Greene	SERC																		
6.	Group	Connie Lowe	Dominion			X		X	X											
<b>Additional Member Additional Organization Region Segment Selection</b>																				
1.	Randi Heise	NERC Compliance Policy	SERC	1, 3, 5, 6																
2.	Louis Slade	NERC Compliance Policy	RFC	5, 6																
3.	Mike Garton	NERC Compliance Policy	NPCC	5																
4.	Larry Nash	Electric Transmission Compliance	SERC	1, 3																
5.	Larry Bateman	Electric Transmission Compliance	SERC	1, 3																
6.	Christopher Mertz	Electric Transmission	SERC	1, 3																
7.	Group	Shannon Mickens	SPP Standards Review Group			X														
<b>Additional Member Additional Organization Region Segment Selection</b>																				
1.	Karl Diekevers	Nebraska Public Power District	MRO	1, 3, 5																
2.	Joe Fultz	Grand River Dam Authority	SPP	1																
3.	Louis Guidry	Cleco Power	SPP	1, 3, 5, 6																
4.	Greg Hill	Nebraska Public Power District	MRO	1, 3, 5																
5.	Stephanie Johnson	Westar Energy	SPP	1, 3, 5, 6																
6.	Bo Jones	Westar Energy	SPP	1, 3, 5, 6																
7.	Mike Kidwell	Empire District Electric	SPP	1, 3, 5																
8.	Tiffany Lake	Westar Energy	SPP	1, 3, 5, 6																

Group/Individual	Commenter	Organization	Registered Ballot Body Segment																	
			1	2	3	4	5	6	7	8	9	10								
9. James Nail	City of Independence, MO	SPP	3, 5																	
10. Robert Rhodes	Southwest Power Pool	SPP	2																	
11. Lynn Schroeder	Westar Energy	SPP	1, 3, 5, 6																	
12. Jason Smith	Southwest Power Pool	SPP	2																	
8. Group	Michael Lowman	Duke Energy				X		X	X											
<b>Additional Member Additional Organization Region Segment Selection</b>																				
1. Doug Hils		RFC	1																	
2. Lee Schuster		FRCC	3																	
3. Dale Goodwine		SERC	5																	
4. Greg Cecil		RFC	6																	
9. Group	Brent Ingebrigtsen	PPL NERC Registered Affiliates				X		X	X											
<b>Additional Member Additional Organization Region Segment Selection</b>																				
1. Charlie Freibert	LG&E and KU Energy, LLC	SERC	3																	
2. Brenda Truhe	PPL Electric Utilities Corporation	RFC	1																	
3. Annette Bannon	PPL Generation, LLC	RFC	5																	
4.	PPL Susquehanna, LLC	RFC	5																	
5.	PPL Montana, LLC	WECC	5																	
6. Elizabeth Davis	PPL EnergyPlus, LLC	MRO	6																	
7.		NPCC	6																	
8.		RFC	6																	
9.		SERC	6																	
10.		SPP	6																	
11.		WECC	6																	
10. Group	Thomas McElhinney	JEA				X		X												
<b>Additional Member Additional Organization Region Segment Selection</b>																				
1. Ted Hobson		FRCC	1																	
2. Garry Baker		FRCC	3																	
3. John Babik		FRCC	5																	
11. Group	Jason Marshall	ACES Standards Collaborators							X											

Group/Individual	Commenter	Organization	Registered Ballot Body Segment											
			1	2	3	4	5	6	7	8	9	10		
<b>Additional Member</b>		<b>Additional Organization</b>	<b>Region</b>	<b>Segment Selection</b>										
1.	Kevin Lyons	Central Iowa Power Cooperative	MRO	1										
2.	Ellen Watkins	Sunflower Electric Power Corporation	SPP	1										
3.	John Shaver	Arizona Electric Power Cooperative/ Southwest Transmission Cooperative, Inc.	WECC	1, 4, 5										
4.	Shari Heino	Brazos Electric Power Cooperative, Inc.	ERCOT	1, 5										
5.	Ryan Strom	Buckeye Power, Inc.	RFC	3, 4, 5										
6.	Mike Brytowski	Great River Energy	MRO	1, 3, 5, 6										
7.	Scott Brame	North Carolina Electric Membership Corporation	RFC	3, 4, 5										
8.	Mark Ringhausen	Old Dominion Electric Cooperative	RFC	3, 4										
9.	Ginger Mercier	Prairie Power, Inc.	SERC	3										
10.	Bob Solomon	Hoosier Energy Rural Electric Cooperative, Inc.	RFC	1										
12.	Group	Kathleen Black	DTE Electric Co.			X	X	X						
<b>Additional Member</b>		<b>Additional Organization</b>	<b>Region</b>	<b>Segment Selection</b>										
1.	Kent Kujala	NERC Compliance	RFC	3										
2.	Daniel Herring	NERC Training & Standards Development	RFC	4										
3.	Mark Stefaniak	Merchant Operations	RFC	5										
13.	Group	Dennis Chastain	Tennessee Valley Authority			X		X	X					
<b>Additional Member</b>		<b>Additional Organization</b>	<b>Region</b>	<b>Segment Selection</b>										
1.	DeWayne Scott	Tennessee Valley Authority	SERC	1										
2.	Ian Grant	Tennessee Valley Authority	SERC	3										
3.	Brandy Spraker	Tennessee Valley Authority	SERC	5										
4.	Marjorie Parsons	Tennessee Valley Authority	SERC	6										
14.	Group	Patricia Robertson	BC Hydro		X	X		X						
<b>Additional Member</b>		<b>Additional Organization</b>	<b>Region</b>	<b>Segment Selection</b>										
1.	Venkataramkrishnan Vinnakota	BC Hydro	WECC	2										
2.	Pat G. Harrington	BC Hydro	WECC	3										
3.	Clement Ma	BC Hydro	WECC	5										
15.	Group	Paul Haase	Seattle City Light			X	X	X	X					

Group/Individual	Commenter	Organization	Registered Ballot Body Segment										
			1	2	3	4	5	6	7	8	9	10	
<b>Additional Member Additional Organization Region Segment Selection</b>													
1.	Pawel Krupa	Seattle City Light	WECC	1									
2.	Dana Wheelock	Seattle City Light	WECC	3									
3.	Hao Li	Seattle City Light	WECC	4									
4.	Mike Haynes	Seattle City Light	WECC	5									
5.	Dennis Sismaet	Seattle City Light	WECC	6									
16.	Group	Andrea Jessup	Bonneville Power Administration			X		X	X				
<b>Additional Member Additional Organization Region Segment Selection</b>													
1.	Dean Bender	System Control Engineering	WECC	1									
2.	Jim Gronquist	Transmission Planning	WECC	1									
3.	Chuck Matthews	Transmission Planning	WECC	1									
17.	Group	Phil Hart	Associated Electric Cooperative, Inc.			X		X	X				
<b>Additional Member Additional Organization Region Segment Selection</b>													
1.	Central Electric Power Cooperative		SERC	1, 3									
2.	KAMO Electric Cooperative		SERC	1, 3									
3.	M & A Electric Power Cooperative		SERC	1, 3									
4.	Northeast Missouri Electric Power Cooperative		SERC	1, 3									
5.	N.W. Electric Power Cooperative, Inc.		SERC	1, 3									
6.	Sho-Me Power Electric Cooperative		SERC	1, 3									
18.	Group	Erika Doot	Bureau of Reclamation					X					
N/A													
19.	Individual	Alshare Hughes	Luminant Generation Company, LLC					X	X	X			
20.	Individual	Maryclaire Yatsko	Seminole Electric Cooperative, Inc.			X	X	X	X				
21.	Individual	Reena Dhir	Manitoba Hydro			X		X	X				
22.	Individual	Andrew Z. Pusztai	American Transmission Company, LLC										
23.	Individual	David Jendras	Ameren			X		X	X				
24.	Individual	John Seelke	Public Service Enterprise Group			X		X	X				
25.	Individual	Michelle D'Antuono	Ingleside Cogeneration LP					X					
26.	Individual	Kayleigh Wilkerson	Lincoln Electric System			X		X	X				

Group/Individual		Commenter	Organization	Registered Ballot Body Segment											
				1	2	3	4	5	6	7	8	9	10		
27.	Individual	Oliver Burke	Entergy Services, Inc.												
28.	Individual	John Merrell	Tacoma Power			X	X	X	X						
29.	Individual	Jamison Cawley	Nebraska Public Power District			X		X							
30.	Individual	Brett Holland	Kansas City Power and Light			X		X	X						
31.	Individual	Thomas Foltz	American Electric Power			X			X						
32.	Individual	Sonya Green-Sumpter	South carolina Electric & Gas			X		X	X						
33.	Individual	Amy Casuscelli	Xcel Energy			X		X	X						
34.	Individual	Michael Moltane	ITC												
35.	Individual	Steve Rueckert	Western Electricity Coordinating Council												X
36.	Individual	Sergio Banuelos	Tri-State Generation and Transmission Association, Inc.			X		X							
37.	Individual	Muhammed Ali	Hydro One			X									
38.	Individual	Anthony Jablonski	ReliabilityFirst												X
39.	Individual	Richard Vine	California ISO		X										
40.	Individual	Spencer Tacke	Modesto Irrigation District			X	X		X						
41.	Individual	Scott Berry	Indiana Municipal Power Agency				X								
42.	Individual	John Brockhan	CenterPoint Energy Houston Electric, LLC												

If you support the comments submitted by another entity and would like to indicate you agree with their comments, please select "agree" below and enter the entity's name in the comment section (please provide the name of the organization, trade association, group, or committee, rather than the name of the individual submitter).

**Summary Consideration:** The drafting team appreciates entities for supporting the comments of other entities rather than duplicating the same or similar comments. Having single sets of comments with documented support greatly improves the efficiency of the standard drafting team. This format also ensures the drafting team has a clearer picture of the number of industry stakeholders supporting the same concerns or suggestions as the case may be. Please see the responses to the entity's comments that are being supported here.

Organization	Agree	Supporting Comments of "Entity Name"
Ameren	Agree	Ameren adopts the SERC PCS comments for PRC-026-1
Lincoln Electric System	Agree	MRO NERC Standards Review Forum (NSRF)
Hydro One	Agree	NPCC - RSC
Indiana Municipal Power Agency	Agree	Comments submitted by Public Service Enterprise Group.



1. **The Protection System Response to Power Swings Standard Drafting Team believes it has addressed industry comments in such a manner that industry consensus can be achieved. If there are remaining unresolved issues in the proposed PRC-026-1 Reliability Standard, please provide your comments here:**

**Summary Consideration:** The following summary discusses the most significant concerns by industry stakeholders. There were several comments that resulted in the standard drafting team making clarifying revisions. There were a number comments that did not result in revisions, in part, because the commenters were asking for feedback on a particular question.

The following summarizes the clarifying revisions made to the Standard beginning with the most notable first. Four comments supported by 30 individuals reported various errors, inconsistencies, or requested clarifying enhancements. The standard drafting team was able to address the vast majority of these observations resulting in a much improved Standard. Four comments supported by 19 industry stakeholder raised concerns about the phrase “become aware” in Requirement R2, Part 2.2. Concerns ranged from who would initiate a review to find out whether or not a stable or unstable power swing was present, how auditors would interpret the phrase, and how this phrase impacts Elements that trip when the entity reviews its Protection System operations. To address this, the standard drafting team appended a footnote to reference the Guidelines and Technical Basis which provide examples that answer stakeholder concerns. The phrase “become aware” was initially inserted into Requirement R2, Part 2.2 during draft 3 to make it clear that an entity is not having to analyze every Protection System operation for a stable or unstable power swing. It is only when an entity “becomes aware” of a power swing on an Element and that Element tripped in response to a stable or unstable power swing would the entity be obligated to evaluate its load-responsive protective relays applied on that Element.

Five comments supported by 26 individuals continue to be concerned about the use of “unstable” in the Requirements. Some believe the use of “unstable” over-reaches the Federal Energy Regulatory Commission (FERC) Order No. 733. Others believe it is unnecessary to evaluate load-responsive protective relays for unstable power swing while others believe that the Standard is mandating that entities set relays properly for unstable power swings. Because of these few remaining concerns, the standard drafting team appended a justification to the end of the Guidelines and Technical Basis to illustrate the importance of having “unstable” as a criterion in the Standard. The Requirements are constructed in a manner that the “unstable” power swing condition only determines that an Element is susceptible along with stable power swings. An Element that trips on an unstable power swing is most likely subjected to numerous stable power swings that may challenge the Protection System. By identifying these Elements, an entity can then evaluate its load-responsive protective relays applied on these Elements and develop a Corrective Action Plan (CAP) when those relays are determined not to meet the PRC-026-1 – Attachment B criteria. The use of “unstable” is not over-reaching the FERC Order No. 733 because the

Requirements only mandate that an entity ensure their load-responsive protective relays are expected to not trip in response to a “stable” power swing during non-Fault conditions.

Four comments supported by 20 stakeholders questioned the use of “one or more” in Requirement R3 regarding the two bulleted items for developing a CAP. The standard drafting team notes that it is possible that both options may be performed to meet the obligations for correcting any load-responsive protective relays that do not meet the PRC-026-1 – Attachment B criteria. After further consideration, the standard drafting team concluded that it is acceptable to limit performance to one of the two available options to achieve the reliability objective of the Standard; therefore, the “or more” phrase was eliminated to avoid confusion that only one bullet had to be performed to be meet the Requirement.

Four comments supported by 19 individuals questioned the potential redundancy with the PRC-004-3 standard that addresses Misoperation identification and correction of Protection Systems. The standard drafting team considered the connection between PRC-004-3 and PRC-026-1 with regard to the Corrective Action Plan (CAP) at great length over the development of the Standard. In the case where an Element trip occurs due to a stable power swing and the trip is identified as a Misoperation (under PRC-004-3) a single CAP is permitted to satisfy both PRC-004 and PRC-026-1. However, in the broader sense, the CAP for PRC-026-1 is specifically intended to ensure that load-responsive protective relays are expected to not trip in response to stable power swings during non-Fault conditions and PRC-004 is intended to identify and correct the causes of Misoperations. In most cases, the action required under each standard will remain separate and distinct whether included in one CAP or separate CAPs. The standard drafting team believes that entities are able to administratively work around, from a compliance standpoint, any special nuances that arise for CAPs that address an identified Misoperation whether due to a stable or unstable power swing and CAPs to meet the PRC-026-1 – Attachment B criteria.

Two comments by 12 individuals believed that FAC-014 is more appropriate for referencing established System Operating Limits (SOL) by the Planning Coordinator than the FAC-010 Standard. The standard drafting team agreed with the comment that FAC-014 more effectively represented the intent; therefore, updated the footnote to point to FAC-014, R3 that is specific to the Planning Coordinator establishing SOLs.

Two comments supported by six stakeholders requested for Requirement R1, Criterion 3 that the word “where” be replaced with “only if.” The standard drafting team agreed that it was clearer and did not change the intent of the Criterion. One comment by five individuals reported various grammatical issues with text in the body of the standard, including the Guidelines and Technical Basis. The standard drafting team agreed with many of the observations and made the corresponding corrections. Two individuals noted that the use of “determine” in the main body of Requirement R2 was redundant with its use in Parts 2.1 and 2.2. The standard drafting team

agreed that the use of “determine” in the main body of Requirement R2 could be eliminated without changing the intent. Single comments that did result in a revision to the Standard are not summarized here and are responded to individually below.

The following summarizes comments made by stakeholders where the standard drafting team did not make any changes to the Standard. Four comments supported by 21 individuals believe a standard is not necessary. The standard drafting team provided a detailed explanation in the Consideration of Comments<sup>2</sup> to Draft 1 of the Standard in the introductory remarks regarding the need for a standard to meet regulatory directives. Two comments supported by 17 stakeholders do not believe the Requirement R1, Criterion 3 concerning islanding should be included. The standard drafting team noted that Requirement R1, Criterion 3 does not require the Planning Coordinator to develop criteria for identifying islands. If the Planning Coordinator has criteria (i.e., as determined under PRC-006) where the island is formed by tripping the Element due to angular instability, then the Planning Coordinator must notify the respective Generator Owner and Transmission Owner. Further, the standard drafting team included this criterion to remain consistent with the PSRPS Report<sup>3</sup> recommendation for facilities to consider.

Two individuals commented that the Planning Coordinator should provide information (e.g., impedance plots) for identified Elements to the respective Generator Owner and Transmission Owner. The standard drafting team did not include any such requirement because this information is not essential for an entity to determine whether its load-responsive protective relays meet the PRC-026-1 – Attachment B criteria. Also, adding a Requirement for the exchange of information does not comport with the results-based standard (RBS) structure. Moreover, a goal during standard development was to keep the burden low on all entities. This included not requiring the Planning Coordinator to develop additional assessments or simulations. For the Generator Owner and Transmission Owner, to only have to evaluate the set of Elements identified by the Planning Coordinator and any Elements that actually trip in response to a stable or unstable power swing. Single comments that did not result in a revision are not summarized here and are responded to individually below.

---

<sup>22</sup> [http://www.nerc.com/pa/Stand/Project%202010133%20Phase%203%20of%20Relay%20Loadability%20stabl/Project\\_2010\\_13.3\\_Consideration\\_of\\_Comments\\_2014\\_08\\_22\\_to\\_Draft\\_1.pdf](http://www.nerc.com/pa/Stand/Project%202010133%20Phase%203%20of%20Relay%20Loadability%20stabl/Project_2010_13.3_Consideration_of_Comments_2014_08_22_to_Draft_1.pdf).

<sup>3</sup> NERC System Protection and Control Subcommittee, *Protection System Response to Power Swings*, August 2013: [http://www.nerc.com/comm/PC/System%20Protection%20and%20Control%20Subcommittee%20SPCS%20/SPCS%20Power%20Swing%20Report\\_Final\\_20131015.pdf](http://www.nerc.com/comm/PC/System%20Protection%20and%20Control%20Subcommittee%20SPCS%20/SPCS%20Power%20Swing%20Report_Final_20131015.pdf)

Organization	Question 1 Comment
<p>SERC Protection and Controls Subcommittee</p>	<p>1) Please make R1, Criterion 3 clearer by replacing ‘where’ with ‘only if’. It then reads            “An Element that forms the boundary of an island in the most recent underfrequency load shedding (UFLS) design assessment based on application of the Planning Coordinator’s criteria for identifying islands, <b>only if</b> the island is formed by tripping the Element due to angular instability.”  <b>Response:</b> Change made.</p> <p>2) Please expand Application Guidelines p20 explanation of Criterion 3 by adding, ‘PC area boundary tie lines, or BA boundary tie lines’ at the end of the last sentence so that it reads “The criterion does not apply to islands identified based on other considerations that do not involve angular instability, such as excessive loading, PC area boundary tie lines, or BA boundary tie lines.”  <b>Response:</b> Change made.</p> <p>3) R1 Criteria 3 and 4, and R2 2.2 identify BES Elements tripped for instability. The Standard’s Purpose is ‘To ensure that load-responsive protective relays are expected to not trip in response to stable power swings during non-Fault conditions.’ (Why do relays that trip on instability need to be evaluated and required to meet this standard?) Please explain that these BES Elements are included because they could be more likely to be challenged by power swings. Their inclusion does not mean that the relays tripping these Elements were necessarily inappropriate. Such an explanation could fit well on page 18 just after “The first step uses criteria to identify the Elements on which a Protection System is expected to be challenged by power swings.”  <b>Response:</b> The standard drafting team has provided additional clarification in the Standard in the Guidelines and Technical Basis section, “Justification for Including Unstable Power Swings in the Requirements” why “unstable” is included.</p> <p>The comments expressed herein represent a consensus of the views of the above-named members of the SERC EC Protection and Control Subcommittee only and should not be construed as the position of SERC Reliability Corporation, its board, or its officers.</p>
<p>CenterPoint Energy Houston Electric, LLC</p>	<p>(1) CenterPoint Energy still feels strongly that there is redundancy between PRC-004 and PRC-026 regarding Corrective Action Plans (CAPs) <b>and must again vote negative</b>. Redundancy is included in the</p>

Organization	Question 1 Comment
	<p>NERC Paragraph 81 (P.81) project as item “B7. Redundant”. Item “B7. Redundant” states the following: “The Reliability Standard requirement is redundant with: (i) another FERC-approved Reliability Standard requirement(s); (ii) the ERO compliance and monitoring program or (iii) a governmental regulation (e.g., Open Access Transmission Tariff, North American Energy Standards Board (“NAESB”), etc.). This criterion is designed to identify requirements that are redundant with other requirements and are, therefore, unnecessary. Unlike the other criteria listed in Criterion B, in the case of redundancy, the task or activity itself may contribute to a reliable BES, but it is not necessary to have two duplicative requirements on the same or similar task or activity. Such requirements can be removed with little or no effect on reliability and removal will result in an increase in efficiency of the ERO compliance program.” Based on our understanding, from responses to comments and also from the recent Q&amp;A webinar, the SDT believes that PRC-026 is more stringent than PRC-004; therefore, PRC-026 requirements for a CAP would supersede those in PRC-004. Mainly, PRC-026 will require a CAP, whereas PRC-004 does not require a CAP if explained “in a declaration why corrective actions are beyond the entity’s control or would not improve BES reliability, and that no further corrective actions will be taken.” We believe such duplicative requirements could send mixed signals where a CAP does not appear to be required (PRC-004) when, in fact, one is required (PRC-026). Should standard PRC-026 be approved as currently written, CenterPoint Energy recommends, due to redundancy, that NERC initiate a project to remove the requirement for a CAP for Protection System operations from power swings in standard PRC-004.</p> <p><b>Response:</b> The standard drafting team considered the connection between PRC-004 and PRC-026 with regard to the Corrective Action Plan (CAP) being redundant at great length over the development of the standard. The standard drafting team notes that in the case where an Element trip occurs due to a stable power swing and is identified as a Misoperation (under PRC-004-3) a single CAP is permitted to be developed to satisfy both PRC-004 and PRC-026. However, in the broader sense, the CAP for PRC-026-1 is specifically intended to ensure that load-responsive protective relays are expected to not trip in response to stable power swings during non-Fault conditions and PRC-004 is to identify and correct the causes of Misoperations of Protection Systems for Bulk Electric System (BES) Elements. In most cases, the action required for each standard will remain separate and distinct whether included in one CAP or separate CAPs.</p> <p>(2) CenterPoint Energy technically disagrees with the SDT’s response that operator-initiated switching to reconnect islands, to restore load during Black Start activities, or to synchronize a generating unit to the system should be applicable to PRC-026. We believe that any Element that tripped in response to a stable</p>

Organization	Question 1 Comment
	<p>or unstable power swing involving restoration and black-starting would be addressed in after-action reviews of those events. We expect that entities will need to coordinate with their Regional Entities to address such circumstances.</p> <p><b>Response:</b> The standard drafting team concluded exclusions for system restoration or black-starting should not be provided because it could be detrimental to reliability. Any Element that tripped in response to a stable or unstable power swing must be addressed, especially involving restoration and black-starting because those are conditions where power swings would be expected and it is critical that load-responsive protective relays are secure for stable power swings. No change made.</p>
<p>ACES Standards Collaborators</p>	<p>(1) The drafting team has continued improving this standard and we thank you for the improvements.</p> <p><b>Response:</b> The standard drafting team thanks you for your comment.</p> <p>(2) We question the need for this standard. In its “Protection System Response to Power Swings” (on page 5) document dated August 2013, the NERC System Protection and Control Subcommittee (SPCS) concluded “that a NERC Reliability Standard to address relay performance during stable power swings is NOT needed, and could result in unintended adverse impacts to the Bulk-Power System reliability” [emphasis added].</p> <p><b>Response:</b> The standard drafting team thanks you for your comment and provided a detailed explanation in the Consideration of Comments<sup>4</sup> to Draft 1 of the Standard in the introductory remarks regarding the need for a standard to meet regulatory directives.</p> <p>(3) The footnote in criterion 2 for Requirement R1 is technically inaccurate and should be modified. An Element would be identified through the application of the PC’s SOL methodology which is required in FAC-014-2 not FAC-010. The methodology must be developed in FAC-010 but application is required in FAC-014-2 R3 and R4.</p> <p><b>Response:</b> The standard drafting team agrees that using “FAC-014-2, Requirement R3” more clearly describes the Planning Coordinator establishing a System Operating Limit or SOL. Clarification made.</p>

<sup>4</sup> [http://www.nerc.com/pa/Stand/Project%202010133%20Phase%203%20of%20Relay%20Loadability%20stabl/Project\\_2010\\_13.3\\_Consideration\\_of\\_Comments\\_2014\\_08\\_22\\_to\\_Draft\\_1.pdf](http://www.nerc.com/pa/Stand/Project%202010133%20Phase%203%20of%20Relay%20Loadability%20stabl/Project_2010_13.3_Consideration_of_Comments_2014_08_22_to_Draft_1.pdf).

Organization	Question 1 Comment
	<p>(3) Why is the word “full” added to “six full calendar months”? We think it only adds confusion in other areas where it is not included. The words six calendar months imply the inclusion of a “full” calendar month.</p> <p><b>Response:</b> The standard drafting team added the clarifier “full” based on previous comments received in early postings of the standard to be clear that partial months are not counted. For example, if the starting point is in the middle of a calendar month, the entity will have until the end of the last month of the stated period. No change made.</p> <p>(4) Requirement R4 should be modified to avoid a registered entity being in technical violation for simply updating their Corrective Action Plan (CAP). As it is written, the applicable entity must both implement the CAP and update the CAP. The problem is that they may be updating the CAP because implementation on the original timeline is not possible. As R4 is written with an “and” condition, this is not possible without a technical violation of the requirement. We suggest changing the second “and” to “or” to address this concern.</p> <p><b>Response:</b> The standard drafting team contends that the primary action in Requirement R4 is to implement the Corrective Action Plan (CAP). The clause after the “and” is conditional based on the entity changing actions or timetables. No change made.</p> <p>(5) Criterion 4 of Requirement R1 requires further explanation. In response to our previous comment questioning the inclusion of unstable power swings in criterion 4 of Requirement R1, the drafting team stated that “this standard does not require that entities assess Protection System performance during unstable swings.” If this is the case, this would support removing “unstable power swings” from criterion 4. What reliability purpose does the PC notifying the GO and TO of Elements susceptible to unstable power swings serve, if the GO and TO are not required to do anything with the information.</p> <p><b>Response:</b> The standard drafting team has provided additional clarification in the Standard in the Guidelines and Technical Basis section, “Justification for Including Unstable Power Swings in the Requirements” why “unstable” is included.</p> <p>(6) Any VRFs that are greater than Lower would seem to be inconsistent with the recommendation of the SPCS (see our point two for the recommendation) that a standard is not needed. Especially, assigning</p>

Organization	Question 1 Comment
	<p>Requirement R2 a VRF of High would seem to a complete rejection of this recommendation. Is this what is intended by the drafting team?</p> <p><b>Response:</b> The standard drafting team assigned a VRF of High to Requirement R2 because the standard is narrowly focusing performance of a sub-set of BES Elements and not all load-responsive protective relays. The failure to evaluate that the Protection System is expected to not trip in response to a stable power swing during a non-Fault condition for a BES Element could contribute to bulk electric system instability, separation, or a cascading sequence of failures, or could place the bulk electric system at an unacceptable risk of instability, separation, or cascading failures, or could hinder restoration to a normal condition. Therefore, Requirement R2 meets a VRF assignment of High and NERC guidance on determining VRFs. Also, other standards that address similar forms of evaluations for Generator Owners and Transmission Owners have VRFs assignments of High. No change made.</p> <p>(7) Should Requirement R3 allow selection of “one or more of the following” or should it be limited to selecting one option? In other words, can a Protection System meet both Criteria A and B simultaneously? If not, then “one or more of the following” should be changed to “either of the following.”</p> <p><b>Response:</b> The standard drafting team notes that in certain cases an entity may perform either or both to meet the Requirement. The Requirement was revised to state “one of the following.” Clarification made.</p> <p>(8) We do not understand why unstable power swings are included in Part 2.2. Per the purpose statement of the standard and the drafting’s prior response to comments (see our bullet 5), the purpose is to prevent tripping of protective relays in response to stable power swings. It is not intended to prevent tripping due to unstable power swings. Thus, why would Part 2.2 compel an evaluation of load-responsive relays for actual tripping due to unstable power swings?</p> <p><b>Response:</b> The standard drafting team has provided additional clarification in the Standard in the Guidelines and Technical Basis section, “Justification for Including Unstable Power Swings in the Requirements” why “unstable” is included.</p> <p>(8) Thank you for the opportunity to comment.</p>
South carolina Electric & Gas	1) Please make R1, Criterion 3 clearer by replacing ‘where’ with ‘only if’. It then reads



Organization	Question 1 Comment
	<p>“An Element that forms the boundary of an island in the most recent underfrequency load shedding (UFLS) design assessment based on application of the Planning Coordinator’s criteria for identifying islands, only if the island is formed by tripping the Element due to angular instability.”</p> <p><b>Response:</b> Change made.</p> <p>2) Please expand Application Guidelines p20 explanation of Criterion 3 by adding, ‘PC area boundary tie lines, or BA boundary tie lines’ at the end of the last sentence so that it reads “The criterion does not apply to islands identified based on other considerations that do not involve angular instability, such as excessive loading, PC area boundary tie lines, or BA boundary tie lines.”</p> <p><b>Response:</b> Change made</p> <p>3) R1 Criteria 3 and 4, and R2 2.2 identify BES Elements tripped for instability. The Standard’s Purpose is ‘To ensure that load-responsive protective relays are expected to not trip in response to stable power swings during non-Fault conditions.’ (Why do relays that trip on instability need to be evaluated and required to meet this standard?) Please explain that these BES Elements are included because they could be more likely to be challenged by power swings. Their inclusion does not mean that the relays tripping these Elements were necessarily inappropriate. Such an explanation could fit well on page 18 just after “The first step uses criteria to identify the Elements on which a Protection System is expected to be challenged by power swings.”</p> <p><b>Response:</b> The standard drafting team has provided additional clarification in the Standard in the Guidelines and Technical Basis section, “Justification for Including Unstable Power Swings in the Requirements” why “unstable” is included.</p>
Duke Energy	<p>“Duke Energy would like to reiterate that we do not believe adequate technical justification has been identified for this project to become a standard. Based on the SPCS recommendation, the SDT and NERC should consider moving this project to a Guideline document until such time as a standard is warranted.”</p>

Organization	Question 1 Comment
	<p><b>Response:</b> The standard drafting team thanks you for your comment and provided a detailed explanation in the Consideration of Comments<sup>5</sup> to Draft 1 of the standard in the introductory remarks regarding the need for a standard to meet regulatory directives.</p>
<p>Associated Electric Cooperative, Inc.</p>	<p>AECI believes that the term unstable power swing should be removed from this standard. Reliability risks associated with unstable swings are already handled with relay protection (PRC) and system study standards (TPL). FERC ordered this drafting team to address issues associated with stable power swings, and the addition of unstable swings in the language is unwarranted. In the previous round of commenting the SDT responded by stating this inclusion was inherent in statements made in the PSRPS report. I would encourage the SDT to also read the following statement from page 19 of that same report, “over-emphasizing secure operation for stable powers swings could be detrimental to Bulk-Power System reliability.” By including unstable power swings within the screening process of R1 more events will qualify for testing and the SDT will have done the very thing the SPCS warned against. An unwarranted emphasis on stable power swings is created when you use unrelated events like unstable swings to define your testing criteria for stable swings. AECI would respectfully request the drafting team removed “unstable” from PRC-026 and keep stable and unstable power swing standards as completely separate as possible, or provide the reliability based risk that exists without the inclusion of this term within the standard.</p> <p><b>Response:</b> The standard drafting team has provided additional clarification in the Standard in the Guidelines and Technical Basis section, “Justification for Including Unstable Power Swings in the Requirements” why “unstable” is included.</p>
<p>DTE Electric Co.</p>	<p>Agree with PSEG comments. The current draft does provide more detailed evaluation basis and examples, however, not all variations in protection schemes are addressed which could result in misapplication of the evaluation criteria.</p> <p><b>Response:</b> Please see our response to PSEG. The standard drafting team believes that it has provided sufficient examples to understand the application of the evaluation criteria. It is not possible to provide an example for every permutation of a protection system.</p>

<sup>5</sup> [http://www.nerc.com/pa/Stand/Project%202010133%20Phase%203%20of%20Relay%20Loadability%20stabl/Project\\_2010\\_13.3\\_Consideration\\_of\\_Comments\\_2014\\_08\\_22\\_to\\_Draft\\_1.pdf](http://www.nerc.com/pa/Stand/Project%202010133%20Phase%203%20of%20Relay%20Loadability%20stabl/Project_2010_13.3_Consideration_of_Comments_2014_08_22_to_Draft_1.pdf).

Organization	Question 1 Comment
<p>Xcel Energy</p>	<p>Although the latest draft of PRC-026 is an improvement, Xcel Energy feels that there are additional opportunities for improvement. We respectfully submit the following comments for the drafting team’s consideration. A new Requirement should be added requiring the PC to provide the system separation angle as part of the notification in order to ensure proper calculation of relay settings. Suggested wording:</p> <p style="padding-left: 40px;">[Each Planning Coordinator shall provide notification of the system separation angle of each identified BES Element(s) in its area that met any of the Criteria in R1, if any, to the respective Generator Owner and Transmission Owner.]</p> <p><b>Response:</b> The standard drafting team chose to use the industry accepted 120 degree separation angle as a screening criterion in order to avoid creating an undue burden on the Planning Coordinator by having to do dynamic studies for every element identified in Requirement R1. Note that PRC-026-1 – Attachment B allows “an angle less than 120 degrees where a documented transient stability analysis demonstrates that the expected maximum stable separation angle is less than 120 degrees.” This analysis could be performed by an entity other than the Planning Coordinator. No change made.</p> <p>Additionally, the 1.05 V Pu voltage is subjective and not based on a study, and contradicts what the GTB says about the AVR:</p> <p style="padding-left: 40px;">“it is more likely that the relay would operate during a power swing when the automatic voltage regulator (AVR) is in manual mode rather than when in automatic mode.”</p> <p>The statement would lead one to believe that</p> <ol style="list-style-type: none"> <li>1- The GO is operating in manual mode in contrast to the VAR standards.</li> <li>2 - That operating in manual mode would keep the unit voltage at 1.05 pu, which is inherently false. Therefore, the calculations in GTB are hypothetical and should not be in a standard, as they provide no reliability assurance.</li> </ol> <p><b>Response:</b> The standard drafting team notes that the AVR may be operated in the manual mode under specific circumstances stated in VAR 002-3 (Requirement R1 and R3). Although operating the AVR in manual mode is not a desired state, VAR 002-3 allows for operation of the AVR in manual mode as directed by the Transmission Operator, during AVR testing, or during unit shutdown. It is also possible that the AVR could be operated in manual mode due to equipment failure (AVR controller failure, generator voltage transformer</p>

Organization	Question 1 Comment
	<p>fuse failure, etc.). It is under these AVR operating scenarios that operating under manual mode with a system perturbation will be most likely to cause a loss of field relay trip during a stable power swing.</p> <p>The reference to 1.05 per unit generator voltage is used to establish a minimum pickup current value for overcurrent relays that are set at or below 15 cycles. The sending and receiving end voltages are established at 1.05 per unit at 120 degree separation. The reference from the Guidelines and Technical Basis is an excerpt from an explanation of the loss-of-field relays and not the overcurrent relays. The generating unit AVR may be operating in "auto" and at this upper voltage level.</p> <p>The reference to FAC-10 in R1 Criterion 2 does not appear to be consistent with its intent since the Planning Coordinator’s methodology per se does not identify/establish the SOLs... instead, they are determined based on applying the methodology, which is required in FAC-014-2.</p> <p>Therefore, assuming there is value in retaining a reference in Criterion 2, it should probably be changed to R3 of FAC-014 that requires SOLs to be established by the Planning Coordinator. Or the reference could be changed to R6 of FAC-014, which specifically pertains to identifying the stability limit SOLs. However, it may be sufficient to have no reference in Criterion 2 as follows:</p> <p style="padding-left: 40px;">“Monitored elements that are part of (angular) stability limit SOLs determined by the Planning Coordinator.”</p> <p><b>Response:</b> The standard drafting team agrees that using “FAC-014-2, Requirement R3” more clearly describes the Planning Coordinator establishing a System Operating Limit or SOL. Clarification made.</p>
<p>American Electric Power</p>	<p>Applicability, Section 4.2 (Facilities):</p> <p>Despite the changes proposed in this most recent draft, our interpretation is the same as it was for the previous version. That being the case, we’re not certain the proposed changes are serving their intended purpose. Could the team provide some insight into what they were trying to clarify or correct with their most recent changes to this section?</p> <p><b>Response:</b> The standard drafting team revised this phrase in response to comments in quality review to use phrasing that is consistent with other Reliability Standard applicability sections. There is no change to the intent or meaning of Section 4.2.</p>

Organization	Question 1 Comment
	<p>R2 and R2.1: Collectively, these requirements read awkwardly due to multiple uses of the word “determine”. We suggest eliminating the first “determine”, so that R2 instead reads “Each Generator Owner and Transmission Owner shall:”.</p> <p><b>Response:</b> The standard drafting team agreed with the suggestion and that removing the first occurrence of “determine” does not substantively change the intent of the requirement as it pertains to Requirement R2, Parts 2.1 and 2.2.</p>
<p>Public Service Enterprise Group</p>	<p>As explained below, we believe there are two unresolved issues.</p> <p>Background</p> <p>PRC-004-3 overlaps PRC-026-1 in several areas. In PRC-004-3, GOs and TOs examine each operation its BES interruption devices to identify Misoperations. Under R5, they must develop a Corrective Action Plan (CAP) unless they “Explain in a declaration why corrective actions are beyond the entity’s control or would not improve BES reliability, and that no further corrective actions will be taken.” In the process of implementing PRC-004-3, “correct operations” are also identified (i.e., interrupting device operations where a Misoperation DID NOT occur), but PRC-004-3 imposes no requirements on correct operations.</p> <p>Misoperations</p> <p>A relay operation during a stable power swing under subpart 2.2 of PRC-026-1 is a Misoperation reportable under PRC-004-3 and subject to a CAP under R5. This same relay operation would be subject to a CAP under R3 of PRC-026-1. In addition, the CAP timelines are different (60 days to develop a CAP in PRC-004-3 and six months to develop it in PRC-026-1). Two standards should not contain requirements that apply to the same Misoperation. To avoid this, we recommend that a new subpart 3.1 should be added in PRC-026-1 as follows:</p> <p style="padding-left: 40px;">R3.1 The development of a CAP pursuant to Requirement R3 shall supersede the requirements for a Generator Owner or Transmission Owner to develop and implement a CAP for a Misoperation pursuant to NERC Reliability Standard PRC-004.</p> <p><b>Response:</b> The standard drafting team considered the connection between PRC-004 and PRC-026 with regard to the Corrective Action Plan (CAP) being redundant at great length over the development of the standard. The standard drafting team notes that in the case where an Element trip occurs due to a stable</p>

Organization	Question 1 Comment
	<p>power swing and is identified as a Misoperation (under PRC-004-3) a single CAP is permitted to be developed to satisfy both PRC-004 and PRC-026. However, in the broader sense, the CAP for PRC-026-1 is specifically intended to ensure that load-responsive protective relays are expected to not trip in response to stable power swings during non-Fault conditions and PRC-004 is to identify and correct the causes of Misoperations of Protection Systems for Bulk Electric System (BES) Elements. In most cases, the action required for each standard will remain separate and distinct whether included in one CAP or separate CAPs.</p> <p>Correct operations</p> <p>Subpart 2.2 of PRC-026-1 also requires knowledge of correct relay operations due to an unstable power swing. As explained above, this information is directly derived from PRC-004-3, but performing a power swing analysis for each correct relay operation would be very burdensome to meet subpart 2.2. The “becoming aware of” language in subpart 2.2 is explained in the Application Guidelines on p. 22 of the standard. This explanation removes the onus of an entity being required to examine each relay operation for the presence of a power swing. We recommend the standard add a footnote to subpart 2.2 that states: “See p. 22 for an explanation of implementing the “becoming aware” language in subpart 2.2.” Because a guideline is not enforceable, such a footnote would tie this guideline language solidly to subpart 2.2.</p> <p><b>Response:</b> The standard drafting team agrees that placing a cross reference in a footnote to the guidelines will provide increased awareness of where examples can be found. A reference to the Guidelines and Technical Basis concerning “becoming aware” footnote has been appended to Requirement R2, Part 2.2. However, the addition of the footnote only serves to increase the visibility of where an entity can find examples. It does not make the information in the guideline part of the enforceable requirement.</p>
Dominion	<p>As mentioned in the Webinar, the upper loss of synchronism circle is based on the ratio of sending-end to receiving-end voltage of 1.43. Looking at the REDLINE copy of PRC-026-1 draft 3, this should be revised in several places,</p> <p>Revisions</p> <p>Page 19 of 98: “ [...] (2) an upper loss-of-synchronism circle based on a ratio of the sending-end to receiving-end voltages of 1.43”</p>

Organization	Question 1 Comment
	<p>Page 31 of 98: “The second shape is an upper loss of synchronism circle based on a ratio of the sending-end to receiving-end voltage of 1.43 (i.e., <math>ES / ER = 1.0 / 0.7 = 1.43</math>).”</p> <p>Page 32 of 98: “Eq. (3): <math>E_S/E_R = 1.0/0.7=1.43</math>”</p> <p>Page 37 of 98: “Shape 2 - Upper Loss of Synchronism Circle With Sending to Receiving Voltage Ratio of 1.43”</p> <p>Page 72 of 98: Table 13 should have an example calculation where <math>ES &lt; ER</math> for the lower loss of synchronism circle and an example calculation where <math>ES &gt; ER</math> for the upper loss of synchronism circle. As discussed with Kevin Jones at Xcel Energy, a revision of Figure 5, on page 41 of 98, changing “Voltage (p.u.)” to the voltage ratio of “ES/ER”, where the ratio extends from 0.7 to 1.43, would align nicely with the edits above.</p> <p><b>Response:</b> Excellent catches on the errors. The standard drafting team has made the above corrections.</p>
<p>American Transmission Company, LLC</p>	<p>ATC accepts the SDT changes.</p> <p><b>Response:</b> The standard drafting team thanks you for your comment.</p>
<p>Kansas City Power and Light</p>	<p>Attachment A</p> <p>The following protection functions should also be excluded from the Requirement of this standard:</p> <ul style="list-style-type: none"> <li>Phase distance relay elements that do not reach beyond the next bus.</li> <li>Loss-of-field relay elements that do not reach beyond the generator impedance.</li> </ul> <p><b>Response:</b> The standard drafting team contends that all impedance elements with a time delay of less than 15 cycles must be evaluated against the PRC-026-1 – Attachment B criteria. For example, a long transmission line with strong sources at each end could result in a Zone 1 relay tripping on a stable power swing, if the relay is not set according to the PRC-026-1 – Attachment B criteria. Even a relay that does not reach beyond the next bus could have a characteristic that is outside the unstable power swing region. No change made.</p>

Organization	Question 1 Comment
<p>Entergy Services, Inc.</p>	<p>Based on the information contained in the SPCS Power Swing Report Dated August 2013, there is insufficient evidence contained in the historical study cases identified, to warrant implementation of the proposed PRC-026-1 standard.”</p> <p><b>Response:</b> The standard drafting team thanks you for your comment and provided a detailed explanation in the Consideration of Comments<sup>6</sup> to Draft 1 of the standard in the introductory remarks regarding the need for a standard to meet regulatory directives.</p>
<p>Tennessee Valley Authority</p>	<p>Based on the proposed implementation plan, it seems that the applicable GO and TO will not be required to perform an initial R2.1 evaluation until the second annual notification is received from the PC. Suggest making the “12 months” in the R1 implementation statement “24 months” unless a practice year was intended for the PC requirement.</p> <p><b>Response:</b> The implementation plan is designed such that the Planning Coordinator will begin notifying the respective Generator Owners and Transmission Owners of any Elements in Requirement R1 based on the effective date language. The 36 months for the Generator Owner and Transmission Owner in Requirement R2 (and Requirements R3 and R4) to become compliant is intended to allow the entity an opportunity to address the initial influx of identified Elements in Requirement R1. There is no obligation on the Generator Owner or Transmission Owner to perform Requirement R2, R3, or R4 until the effective date of these Requirements. Although there is no compliance obligation during the 36 month implementation period, an entity will have the full obligation of Requirements R2, R3, and R4 following the 36 month period. The 36 month implementation period also allows an opportunity for the entity to establish the evaluation of load-responsive protective relays pursuant to Requirement R2 which will provide the point in time that the five year re-evaluation of such relays will occur. “No change made.</p> <p>Consider making the implementation date for R3 and R4 lag the implementation date of R2 by six months. The R3 requirement allows for six months to develop a CAP following completion of work associated with R2.</p>

<sup>6</sup> [http://www.nerc.com/pa/Stand/Project%202010133%20Phase%203%20of%20Relay%20Loadability%20stabl/Project\\_2010\\_13.3\\_Consideration\\_of\\_Comments\\_2014\\_08\\_22\\_to\\_Draft\\_1.pdf](http://www.nerc.com/pa/Stand/Project%202010133%20Phase%203%20of%20Relay%20Loadability%20stabl/Project_2010_13.3_Consideration_of_Comments_2014_08_22_to_Draft_1.pdf).



Organization	Question 1 Comment
	<p><b>Response:</b> The standard drafting team notes that in order to begin measuring the six months required as part of the performance in Requirement R3, the requirement itself must be “active.” Because there is six months built into the performance of the requirement, the implementation plan would not reflect this timing aspect since the implementation timing has to do with when the requirement becomes effective (i.e., active). The dates have been aligned to accomplish this and entities still have the full six months lag in the requirement before performance would be due. Adding this to the implementation timing would only serve to misalign the timing needed. Requirement R4 begins upon development of the Corrective Action Plan in Requirement R3; therefore, Requirement R4 must become “active” at the same time as Requirement R3. No change made.</p> <p>To align with the change made to requirement R2 regarding evaluations performed in the last five calendar years, consider making the effective date of R2 the “First day of the first full calendar year that is 60 months after the date....”Page number references in the following comments apply to the redline posting.</p> <p><b>Response:</b> The additional time for Requirement R2 to become effective in the implementation plan is provided to handle the initial influx of notifications and identifications of Elements by the Planning Coordinator. The five-year interval is based on the anticipated amount of time before system changes would require re-evaluation of protective relays. The standard drafting team concluded that a five year implementation period was too long and that three years provides adequate time to evaluate the initial influx of notifications and identifications of Elements by the Planning Coordinator. The team considered the 60 months requested and determined that three years is sufficient time to handle the influx of notifications. No change made.</p> <p>Page 19: Within the “Rationale for Attachment B (Criteria A)” box shaded blue, should “... varying from 0.7 to 1.0 per unit...” be changed to “varying from 0.0 to 1.0 per unit...” to match the change made in the preceding Criteria A section?</p> <p><b>Response:</b> The standard drafting team notes that the union of the lens with the two circles limits the voltage range of the unstable power swing region’s boundary from 0.7 to 1.0. No change made.</p> <p>Page 24: In the Requirement R1 section, recommend replacing the last sentence with “It is possible that a Planning Coordinator will utilize prior year studies in determining their requirement R1 Elements list each year.”</p>

Organization	Question 1 Comment
	<p><b>Response:</b> Change made.</p> <p>Page 25: In the Requirement R1, Criterion 1 section, suggest changing            “The 66 kV transmission line is not electrically joined to the 345 kV and 230 kV transmission lines at the plant site and is not a part of the operating limit or RAS.”            to            “The 66 kV transmission lines are not electrically joined to the 345 kV and 230 kV transmission lines at the plant site and are not a part of the operating limit or RAS.” since there is more than one 66 kV line in the example.</p> <p><b>Response:</b> Change made.</p> <p>Page 25: In the Requirement R1, Criterion 2 section, since the acronym SOL is now spelled out in the Criterion 1 section, the acronym can be used in the Criterion 2 section without spelling it out.</p> <p><b>Response:</b> The standard drafting team notes that because a reader may go directly to Criterion 2 without reading the preceding section and may not know what is meant by the acronym SOL, the full phrase is used. No change made.</p>
BC Hydro	<p>BC hydro does not agree with the proposed new reliability standard PRC-026-1. In the past 15 years with approximately 1000 faults per year on the transmission system, there has not been a single undesired protection operation on a stable power swing. There have been some protection operations on power swings, but they were desirable, and separated systems that were about to go out of step. BC Hydro has a very large portion of its transmission system that is subject to stability constraints. Therefore, even the focussed approach proposed in the new standard will present a significant amount of engineering resources to perform the stability checks and protection response checks to determine whether setting modifications or addition of power swing blocking relays or whether exemptions are required. BC Hydro recommends that the new standard not be implemented, or if it is implemented, that the WECC region be exempted in view of the fact that the transmission network is sparse, with many stability constraints. The work required to meet this standard will be excessive, even with the focussed approach proposed.</p>

Organization	Question 1 Comment
	<p><b>Response:</b> The standard drafting team is addressing Federal Energy Regulatory Commission (FERC) Order No. 733 directives to address stable power swings. The standard is using an equally effective and efficient approach in addressing the directive by implementing the narrow focus recommended by the NERC System Protection and Control Subcommittee technical report on a continent-wide basis. The standard drafting team recognizes that there will be cases where Reliability Standards impact one entity more significantly than others when addressing certain risks. No change made.</p>
<p>Bonneville Power Administration</p>	<p>BPA has no unresolved issues.</p> <p><b>Response:</b> The standard drafting team thanks you for your comment.</p>
<p>ITC</p>	<p>Edit R2.2 to include, “...due to the operation of its protective [functions described in Attachment A], determine...”</p> <p><b>Response:</b> The standard drafting team contends that “due to the operation of its protective relay(s)” is the proper phrase. Any relay trip in response to a power swing is an indication that the Element has experienced a power swing significant enough to warrant evaluation of the Element’s load responsive relays. No change made.</p> <p>Modern relays which enable power swing blocking functions result in time-delayed clearing for subsequent 3 phase faults. E.g. SEL-411L manual states “Three-phase faults will be detected with a minimum and maximum time delay of two and five cycles, respectively.” More conventional power swing blocking functions result in time delays much longer than 5 cycles, possibly exceeding 1 second. Does the SDT believe this is “dependable fault detection”?</p> <p><b>Response:</b> The standard drafting team notes that the Guidelines and Technical Basis provides information on this phrase. The determination of “dependable fault detection” and acceptable tripping delay is outside the scope of this standard and should be governed by other existing reliability standards and industry practices. No change made.</p> <p>Does the SDT believe this contributes to the reliability of the BES?</p> <p><b>Response:</b> The standard drafting team contends that installing out of step blocking normally promotes reliability of the BES. If the application of power swing blocking using a particular type of protection</p>

Organization	Question 1 Comment
	<p>scheme can be shown to degrade reliability for a given location, other alternatives should be considered to meet the requirements of this standard. No change made.</p> <p>Edit page 79, “Double blinder schemes are more complex [than] the single...”</p> <p><b>Response:</b> The standard drafting team corrected the error.</p> <p>R1 Criteria 3 remains unclear. PRC-006 does not seem to require the level of detail required for PCs to meet this requirement. Our concerns are that PCs will commit much more resources to developing this level of detail or absent that level of detail will identify all or none of the boundary elements as meeting this criteria.</p> <p><b>Response:</b> The standard drafting team contends that it is up to the discretion of the Planning Coordinator as to whether it addresses angular stability under PRC-006-1 – Automatic Underfrequency Load Shedding. No change made.</p>
Western Electricity Coordinating Council	<p>I don't have any concerns with the standard as drafted. However, you may wish to make a grammatical review of the language of R2. the word "determine" is included in the language of R2 (last word) as well as in Parts 2.1 and 2.2. It seems like it is not needed both times.</p> <p><b>Response:</b> The standard drafting team agreed with the suggestion and that removing the first occurrence of “determine” does not substantively change the intent of the Requirement as it pertains to Requirement R2, Parts 2.1 and 2.2.</p>
Tacoma Power	<p>In general, Tacoma Power agrees that the Power Swings Standard Drafting Team has addressed industry comments in such a manner that industry consensus can be achieved. However, Tacoma Power does have some other relatively minor suggestions. (In general, these comments were identified by reviewing the draft with redlines.)</p> <p>1. Consider modifying Requirement R3 as follows. Change “...does not meet the PRC-026-1 - Attachment B criteria...” to “...does not meet the PRC-026-1 - Attachment B criteria pursuant to Requirement R2...” This may be implied, but the language in Requirement R3 does not tie back to Requirement R2.</p>

Organization	Question 1 Comment
	<p><b>Response:</b> The standard drafting team agrees with the suggestion that it adds clarity that Requirement R3 is contingent upon Requirement R2. Clarification made.</p> <p>2. In the Rationale for R3, it seems like the reference to Requirement R2 should be a reference to Requirement R3.</p> <p><b>Response:</b> The standard drafting team agrees and has corrected the reference.</p> <p>3. The criteria headings in Attachment B should read as Criterion A and Criterion B.</p> <p><b>Response:</b> Change made.</p> <p>4. Under Attachment B, Criterion B, Condition 2, all transmission BES Elements cannot be in their normal operating state if the parallel transfer impedance has been removed. It is understood that all transmission BES Elements would be in their normal operating state with the exception that the parallel transfer impedance should be removed.</p> <p><b>Response:</b> The standard drafting team notes that “...all transmission BES Elements are in their normal operating state...” when calculating the system impedances (i.e., sending-end, receiving-end, and parallel transfer impedance). The parallel transfer impedance is then removed when evaluating the Element pursuant to the criteria.</p>
<p>Ingleside Cogeneration LP</p>	<p>Ingleside Cogeneration L.P. (ICLP) has carefully read through the latest draft of PRC-026-1 and its supporting documents, but still <b>must deliver a “No” vote</b>. We fully understand the regulatory need to adhere to FERC’s December 31 deadline, but believe that the intent of the drafting team is not captured in the enforceable parts of the standard itself.</p> <p>On a positive note, this means that we believe that the technical aspects of PRC-026-1 are sound - which means that the most difficult work has been performed. ICLP would like to compliment the project team on their ability to construct a process that narrows the universe of load relays that may improperly react to stable power swings, offsetting the arguments that the standard does not serve a reliability purpose. However, several key logistical issues remain. In our view, if these remain uncorrected, we cannot be sure that CEAs will administer the standard evenly across all eight Regions.</p> <p>Our specific recommendations are as follows:</p>

Organization	Question 1 Comment
	<p>1) There must be clarity in the methods used to identify load relay that react improperly to a stable or unstable power swing. The project team has articulated in their Consideration of Comments that Events Analysis and/or a PRC-004 Misoperation study are the triggers that they visualize. However, these concepts are not binding to CEAs - who we believe will demand evidence that every load relay trip was investigated and proved to be not-applicable. In addition, a TO or GO who does not properly identify a stable or unstable power swing will be held in violation of PRC-026-1. This is not a capability or expertise that equipment owners possess, and should not be held accountable for.</p> <p>The project team resolved a similar issue by adding a footnote reference to FAC-010 in R1, and ICLP believes that the same could be done for R2. The footnote would simply capture the fact that the potentially deficient load relay would be identified through the Events Analysis process and/or a Misoperation study.</p> <p><b>Response:</b> The standard drafting team notes although it cannot address the consistency in auditing across the regions; however, the drafting team appended a footnote to Requirement R2, Part 2.2 to reference the Guidelines and Technical Basis concerning “becoming aware.” This will serve to increase the reader’s awareness of the intent of this phrase. Requirement R2, Part 2.2 is structured where the stable or unstable power swing must be identified that is connected with the entity’s Element tripping to avoid the need to address all Element trips. The explanation and examples in the Guideline referenced through the footnote remain explanatory only and are not part of the mandatory requirement. The NERC standard developer will also share this comment with the RSAW development team for further consideration of clarifying notes in the RSAW. Clarification made.</p> <p>2) The project team has made it clear that a trip in response to an unstable power swing is a screening factor - not a deficient condition. However, no change has been made despite multiple requests to do so. Perhaps the project team believes that there is already sufficient clarity in the requirements, but ICLP disagrees. As written, we believe that some CEAs will demand corrective action in response to an unstable power swing - an improper use of scarce resources better applied elsewhere. A modification to R2 to address the screening intent of unstable power swings can be easily done in order to avoid this situation.</p> <p><b>Response:</b> The standard drafting team notes that Requirement R2 drives the evaluation of load-responsive protective relays for BES Elements that have been identified by Requirement R2, Parts 2.1 and 2.2 (stable or unstable power swings). Requirement R3 requires the entity to meet the performance where the load-</p>

Organization	Question 1 Comment
	<p>responsive protective relay is expected to not trip in response to a stable power swing by meeting PRC-026-1 – Attachment B criteria (i.e., stable power swings only). If the criteria is not met, the entity must develop a Corrective Action Plan (CAP) that meets the conditions in Requirement R3. No change made.</p>
<p>Nebraska Public Power District</p>	<p>It is clear the drafting team has put a great amount of effort into this standard which is quite complex. This effort is appreciated. Comments for consideration:</p> <p>R2.2 states: Within 12 full calendar months of becoming aware of a generator, transformer, or transmission line BES Element that tripped in response to a stable or unstable power swing due to the operation of its protective relay(s), determine whether its load-responsive protective relay(s) applied to that BES Element meets the criteria in PRC-026-1 - Attachment B. R2.2 hinges on “becoming aware” which seems will be difficult to prove or audit. The drafting team felt that it is not needed to prove how an entity addresses “becoming aware” but the RSAW indicates that an auditor should “(R2) Interview an entity representative to understand the entity’s process for identifying applicable load-responsive protective relays applied on the terminals of the BES Elements identified pursuant to Requirement R2, Parts 2.1 and 2.2”. R2.2 seems to be a very vague and unpredictable part to R2. The standard would be much cleaner without 2.2.</p> <p><b>Response:</b> The standard drafting team agrees that placing a cross reference in a footnote to the guidelines will provide increased awareness of where examples can be found. A reference to the Guidelines and Technical Basis concerning “becoming aware” footnote has been appended to Requirement R2, Part 2.2. However, the addition of the footnote only serves to increase the visibility of where an entity can find examples. It does not make the information in the guideline part of the enforceable requirement.</p> <p>Requirement R2, Part 2.2 is important to reliability because it addresses actual events. This part is also consistent with the PRSRP Report<sup>7</sup> recommendation.</p> <p>A trip on a stable power swing will most likely be a misoperation and will be addressed per other NERC standards (e.g. PRC-004, PRC-016). A trip on an unstable power swing may or may not be a misoperation depending on if the relaying was set to trip for OOS or not. It seems the only benefit to 2.2 then is to</p>

<sup>7</sup> NERC System Protection and Control Subcommittee, *Protection System Response to Power Swings*, August 2013: [http://www.nerc.com/comm/PC/System%20Protection%20and%20Control%20Subcommittee%20SPCS%2020/SPCS%20Power%20Swing%20Report\\_Final\\_20131015.pdf](http://www.nerc.com/comm/PC/System%20Protection%20and%20Control%20Subcommittee%20SPCS%2020/SPCS%20Power%20Swing%20Report_Final_20131015.pdf)

Organization	Question 1 Comment
	<p>identify correct trips for unstable swings and this does not seem to add significant reliability compared to the burden and audit risks. Consider removal of 2.2.</p> <p><b>Response:</b> The standard drafting team has provided additional clarification in the Standard in the Guidelines and Technical Basis section, “Justification for Including Unstable Power Swings in the Requirements” why “unstable” is included.</p> <p>The standard drafting team considered how the determination of Misoperations interacts with the PRC-026-1 standard. PRC-004 addresses the identification and correction of Misoperations and PRC-026-1 addresses Elements that have tripped in response to stable or unstable power swings, and if so, evaluate load-responsive protective relays to ensure these relays are expected to not trip in response to stable power swings according to the PRC-026-1 – Attachment B criteria. The action required for each standard will remain separate and distinct whether included in one CAP or separate CAPs.</p> <p>Requirement R2, Part 2.2 is important to reliability because it addresses actual events. This part is also consistent with the PRSRP Report<sup>8</sup> recommendation.</p> <p>During the 11-13-2014 webinar some concerns were noted regarding the guidelines and technical basis equations and calculations. Since a significant portion of this document is devoted to calculations it is beneficial these be as accurate as possible since it will be a part of compliance. Any reevaluations and rechecks of these calculations are greatly appreciated. There is concern with voting yes until the final checks can be made.</p> <p><b>Response:</b> The standard drafting team notes that comments from Dominion, herein, provide comments on the errors discussed during the November 13, 2014 Questions and Answers session held by the standard drafting team. These errors were addressed with the help of Dominion staff.</p> <p>In addition to these comments, we also support the comments submitted by SPP.</p> <p><b>Response:</b> The standard drafting team thanks you for supporting the comments of others. Please see the responses to the SPP Standards Review Group.</p>

<sup>8</sup> NERC System Protection and Control Subcommittee, *Protection System Response to Power Swings*, August 2013: [http://www.nerc.com/comm/PC/System%20Protection%20and%20Control%20Subcommittee%20SPCS%2020/SPCS%20Power%20Swing%20Report\\_Final\\_20131015.pdf](http://www.nerc.com/comm/PC/System%20Protection%20and%20Control%20Subcommittee%20SPCS%2020/SPCS%20Power%20Swing%20Report_Final_20131015.pdf)



Organization	Question 1 Comment
<p>Luminant Generation Company, LLC</p>	<p>Luminant continues to believe that including unstable power swings in the draft standard goes beyond FERC Order 733. Luminant understands that adding unstable power swings in the Requirement only requires the Generator Owner to be compliant with the criteria in Requirement R3 (Attachment B) for any of the load-responsive relays in Attachment A. However, Requirement R1 (part 4) provides information to the Generator Owner that some units may be subject to an out-of-step condition and action on their part may be necessary to enable generator out-of-step protection. Luminant recommends that either “unstable” be removed from the standard in all requirements or add language to Measure M1 for the Planning Coordinator to provide information (for example, impedance plots) to the Generator Owner that describe the location of the electrical center for an out-of-step condition.</p> <p><b>Response:</b> It is important to note that this standard does not require that entities assess Protection System performance during unstable swings and does not require entities to prevent tripping in response to unstable swings. Such requirements would exceed the directive stated in the Federal Energy Regulatory Commission (FERC) Order No. 733. This standard focuses on the identification of Elements by the Planning Coordinator (Requirement R1) and Elements where the Generator Owner or Transmission Owner becomes aware of an Element that tripped in response to a stable or unstable power swing (Draft 3, Requirement R2, 2<sup>nd</sup> bullet). Requirements R1 and R2 (2<sup>nd</sup> bullet) is a screen to identify Elements that are subject to the Requirements of the standard.</p> <p>The standard drafting team has provided additional clarification in the Standard in the Guidelines and Technical Basis section, “Justification for Including Unstable Power Swings in the Requirements” why “unstable” is included.</p> <p>The standard drafting team chose not to include communication requirements between the Generator Owner and Transmission Owner for the exchange of impedance plot information at a given transmission interconnection point. A communication Requirement for the exchange of information would be administrative in nature, and would create additional compliance tracking burdens for both entities.</p>
<p>ReliabilityFirst</p>	<p>ReliabilityFirst votes in the Affirmative and believes the PRC-026-1 standard enhances reliability and ensures that load-responsive protective relays are expected to not trip in response to stable power swings during non-Fault conditions. ReliabilityFirst offers the following comments for consideration:</p>

Organization	Question 1 Comment
	<p>1. Requirement R2 - the language regarding who determines whether or not a stable or unstable power swing has occurred is vague. The associated application notes state that the SDT purposefully avoided making the GO or TO responsible for that determination and allude that possibly the GO or TO, the RE or NERC during an event analysis could be the source. Unfortunately, this wording sets up a lot of finger pointing as to who was responsible to launch the analysis of the compliance of PRC-026 with the event. ReliabilityFirst recommends including language clearly identifying the source of who determines whether or not a stable or unstable power swing has occurred as referenced in Requirement R2.</p> <p><b>Response:</b> The standard drafting team agrees that placing a cross reference in a footnote to the guidelines will provide increased awareness of where examples can be found. A reference to the Guidelines and Technical Basis concerning “becoming aware” footnote has been appended to Requirement R2, Part 2.2. However, the addition of the footnote only serves to increase the visibility of where an entity can find examples. It does not make the information in the guideline part of the enforceable requirement.</p> <p>Also, Requirement R2, Part 2.2 does not require re-evaluation on a periodic basis and is only triggered by actual events. The standard drafting team concluded that in those rare cases where an event included tripping in response to stable or unstable power swings, that the Generator Owner and Transmission Owner must evaluate its load-responsive protective relays due to the event; however, subsequent review would not be necessary on an ongoing basis. Clarification made.</p>
Seminole Electric Cooperative, Inc.	<p>Requirement R1 “Element” in R1 on page 6 of the redline was revised to “generator, transformer, and transmission line BES Element.” It’s unclear whether “transmission line BES Element” includes terminal equipment of the transmission line.</p> <p><b>Response:</b> The standard drafting team modified the language in the Applicability section and Requirements in the previous Draft 3 to more clearly note that Requirement R1 is applicable to three types of BES Elements (i.e., “generator, transformer, and transmission line”). By definition of “Element” the terminal equipment may be included as a part of the Element. No change made.</p> <p>It’s unclear whether a “generator BES Element” includes a generator Facility, i.e., the generator itself or merely those Elements that make up the generator. Seminole requests the drafting team add additional language as to what is actually covered under R1.</p>

Organization	Question 1 Comment
	<p><b>Response:</b> The standard drafting team notes that the term “generator,” as used in Requirement R1, is specific to the generating unit and not other elements that make up a generator facility.</p> <p>PRC-026-1 - Attachment B</p> <p>Under Criteria B on page 20 of the redline version, #2 states “All generation is in service and all transmission BES Elements are in their normal ... .” Seminole requests the drafting team explain how the “transmission BES Elements” listed here are different than “Transmission BES Elements” (Transmission with a capital T)?</p> <p><b>Response:</b> The standard drafting team revised the use of the capitalized version of “Transmission system” to lower case. The occurrences of “Transmission station” appropriately reflect the standard drafting team’s intent to reference the term “Transmission” as defined in the <i>Glossary of Terms Used in NERC Reliability Standards</i> (NERC Glossary). Occurrences of the phrase “...generation is in service and all transmission BES Elements...” does not refer to the NERC Glossary and is intended to be used in the normal understanding of “generation” and “transmission.”</p>
Seattle City Light	<p>Seattle City Light appreciates the efforts of the Standards Drafting Team to respond to comments and clarify the proposed draft. Seattle, however, continues to believe that the proposed Standard is not warranted by the history of major electrical outages. Seattle further finds the proposed Standard to be based on theoretical concepts rather than practical experience, and as such, proposes a largely untried process to become a rigid federal regulation having continental reach. Recent industry experience suggests the difficulty of such an approach. Consider industry experience with another new concept, that of the NERC “Order 754” effort. Considerable back-and-forth exchange and flexibility was required of this effort before well-meaning entities across the continent--each having different configurations, equipment, and characteristics--were able apply a new, untried process to reach a desired and consistent result.</p> <p>Furthermore, as the drafting team will recall, the Order 754 request required some three years to complete, and first year was spent almost entirely in clarifications and modifications. The clarifications and modifications were necessary to address the differing equipment and configurations of diverse entities, configurations and equipment that had not been considered by the team that framed the request. Matters came up as fundamental as “what is meant by the term ‘bus’ in the request?” (in the end, ‘bus’ was defined to mean one thing for one part of the request and defined as something else for another part). Given the</p>

Organization	Question 1 Comment
	<p>diversity of entities in North America, how could any team, no matter how strong, be expected to conceive of all possible arrangements with no application experience to guide them? Consider now that the proposed Standard is just as untried as the Order 754 request and is rather more complex. Moreover, as a mandatory reliability Standard it would lack the implementation flexibility that allowed successful completion of the Order 754 request. Consequently Seattle is deeply concerned about the effectiveness of the proposed approach in improving the reliability of the bulk electric system in the near term. Rather it appears more likely to drive a bow-wave of compliance violations as numerous entities struggle to apply new theoretical processes that do not fit their situation and circumstances, and regulators struggle to figure out how to audit a misfit Standard. As such, Seattle votes Negative on this ballot and expects to do so in future ballots as well. Seattle would consider an Affirmative position if the draft Standard was put on hold and a 1-2 year pilot program run in its place. Such a pilot program could be structured as a mandatory reporting exercise somewhat like the Order 754 effort: reporting would be required but results would not be audited for compliance (rather used for learning). Alternatively, a pilot program might be structured to focus on a small number of entities such as the recent CIP v5 pilot program (with the difference that no PRC-026-1 Standard would be adopted, until after the pilot when lessons learned could be incorporated into it). Once experience had been acquired with the real-world application of the proposed PRC-026-1 requirements, and the Standard revised to accommodate these lessons, then Seattle would consider an Affirmative vote. Should a pilot program be implemented, Seattle would be willing to serve a test entity.</p> <p><b>Response:</b> The standard drafting team thanks you for your comments. The ideas presented concerning a field trial will be referred to NERC staff for further consideration.</p>
Bureau of Reclamation	<p>The Bureau of Reclamation (Reclamation) supports the proposed PRC-026-1. Reclamation appreciates the drafting team’s efforts revising the Applicability, Requirements, and Measures to clarify which entities will be required to complete stable power swing analysis for which qualifying facilities and elements.</p> <p><b>Response:</b> The standard drafting team thanks you for your comments.</p>
California ISO	<p>The California ISO does not agree with the change to remove the Transmission Planner in the Applicability section and in Requirement R1. The California ISO supports continuing to include the Transmission Planner in Requirement R1 as suggested by the PSRPS Report.</p>

Organization	Question 1 Comment
	<p><b>Response:</b> The standard drafting team removed the Transmission Planner (and Reliability Coordinator) as applicable entities in Draft 2 of the proposed standard in response to comments on Draft 1 to address concerns about overlap and potential gaps when identifying Elements in Requirement R1. Although the PSRPS Report<sup>9</sup> suggested entities for applicability, the standard drafting team agreed with industry comments received on Draft 1 that the Planning Coordinator is in the best position to identify the BES Elements for notification to avoid duplication and potential gaps. No change made</p>
PacifiCorp	<p>The drafting team should eliminate or revise criterion 3 under PRC-026-1 R1. PRC-006 studies are performed to help ensure sufficient load is available to be shed during extreme events to help arrest frequency decline within an island. Since there are a large number of potential but very low probability extreme events that could result in island formation, UFLS programs applied to small loads dispersed throughout the interconnected system in order to increase the likelihood that potential islands include load that can be shed. Since many of these potential islands and the elements that open to form them are highly speculative, R1 Criteria 3, if it is kept, should be modified to limit its application to elements associated with actual events or specifically designed island boundaries. The Planning Coordinator should not be required to develop a criteria for identifying islands.</p> <p><b>Response:</b> The standard drafting team notes that Requirement R1, Criterion 3 does not require the Planning Coordinator to develop criteria for identifying islands. If the Planning Coordinator has criteria (i.e., as determined under PRC-006) where the island is formed by tripping the Element due to angular instability, then the Planning Coordinator must notify the respective Generator Owner and Transmission Owner. Further, the standard drafting team included this criterion to remain consistent with the PSRPS Report<sup>10</sup> recommendation for facilities to consider. No change made.</p>
ISO RTO Council Standards Review Committee	<p>The IRC SRC appreciates the drafting team’s efforts in addressing industry concerns, especially those we submitted in the prior posting. We believe our concerns have been addressed, but respectfully suggest the following small clarification regarding Requirement R3:</p>

<sup>9</sup> NERC System Protection and Control Subcommittee, *Protection System Response to Power Swings*, August 2013: [http://www.nerc.com/comm/PC/System%20Protection%20and%20Control%20Subcommittee%20SPCS%2020/SPCS%20Power%20Swing%20Report\\_Final\\_20131015.pdf](http://www.nerc.com/comm/PC/System%20Protection%20and%20Control%20Subcommittee%20SPCS%2020/SPCS%20Power%20Swing%20Report_Final_20131015.pdf)

<sup>10</sup> Ibid, page 21 of 61, 4<sup>th</sup> bullet.

Organization	Question 1 Comment
	<p>Each Generator Owner and Transmission Owner shall, within six full calendar months of determining, pursuant to R2, that a load-responsive protective relay does not meet the PRC-026-1 - Attachment B criteria, develop a Corrective Action Plan (CAP) to meet one or more of the following....</p> <p>Thank you for the additional comment opportunity.</p> <p><b>Response:</b> The standard drafting team agrees with the suggestion that it adds clarity that Requirement R3 is contingent upon Requirement R2. Clarification made.</p>
<p>MRO NERC Standards Review Forum</p>	<p>The NSRF believes that the Industry concerns have not been adequately addressed.</p> <p>Request that the drafting clarify its scope of applicability between NERC defined “Elements” and “Facilities” in Section 4.2. Did the drafting team mean only BES generators, transmission lines, and transformers? If so, please clarify this sub set is the only applicable items.</p> <p><b>Response:</b> The standard drafting team modified the language in the Applicability section and Requirements in the previous Draft 3 to more clearly note the standard is applicable to three types of BES Elements (i.e., “generator, transformer, and transmission line”). By definition of “Element” the terminal equipment may be included as a part of the Element.</p> <p>The drafting team should eliminate or revise criterion 3 under PRC-026-1 R1. UFLS islands are rare and UFLS islands mandated by PRC-006 are likely best guess conditions. Therefore unless criterion 3 under R1 is modified to apply only to known and designed stability power protection systems, the work performed would be a best guess and of little practical value. At a minimum, criterion 3 could be further clarified by adding a sentence such as the following, “Criterion 3 does not apply to other conditions such as excessive loading.”</p> <p><b>Response:</b> The standard drafting team notes that Requirement R1, Criterion 3 does not require the Planning Coordinator to develop criteria for identifying islands. If the Planning Coordinator has criteria (i.e., as determined under PRC-006) where the island is formed by tripping the Element due to angular instability, then the Planning Coordinator must notify the respective Generator Owner and Transmission</p>

Organization	Question 1 Comment
	<p>Owner. Further, the standard drafting team included this criterion to remain consistent with the PSRPS Report<sup>11</sup> recommendation for facilities to consider. No change made.</p> <p>FERC has defined that the requirements govern compliance (FERC O 693 sect. 253), unless the words “non-fault power swings” are added to R2 similar to the PRC-026 purpose correctly limiting the number of evaluations to non-fault conditions, a regulatory entity could determine an entity was in non-compliance for not evaluating stable or unstable power swings for fault conditions after an event for “impedance based relays identified in Attachment</p> <p><b>Response:</b> The standard drafting team contends that the use of “non-Fault” in the Purpose describes the standard’s intent to “...ensure that load-responsive protective relays are expected to not trip in response to stable power swings during non-Fault conditions...” where the non-Fault condition applies to the Element(s) the relays are protecting. The evaluation, in the case of Requirement R2 for actual events, comes into scope upon becoming aware of a generator, transformer, or transmission line BES Element that tripped in response to a stable or unstable power swing due to the operation of its protective relay(s) for a non-Fault condition on the protected Element.</p> <p>The use of “non-fault” in PRC-026 R2 would clearly separate PRC-026 from PRC-004 which already governs analysis and corrective actions for protection systems mis-operations usually with respect to fault conditions. This separation will avoid a potential double jeopardy violation where PRC-026 and PRC-004 could be interpreted to overlap for relay analysis of a misoperation.</p> <p><b>Response:</b> The standard drafting team discussed the relationship between the proposed PRC-026-1 and PRC-004-3 (recently NERC Board adopted). The use of “non-Fault” does not separate PRC-026-1 from PRC-004-3 because PRC-004-3 addresses the categories of “Other Than Fault” with regard to identifying Misoperations.</p> <p>The standard drafting team considered the connection between PRC-004 and PRC-026 with regard to the Corrective Action Plan (CAP) being redundant at great length over the development of the standard. The standard drafting team notes that in the case where an Element trip occurs due to a stable power swing and is identified as a Misoperation (under PRC-004-3) a single CAP is permitted to be developed to satisfy</p>

<sup>11</sup> Ibid, page 21 of 61, 4<sup>th</sup> bullet.

Organization	Question 1 Comment
	<p>both PRC-004 and PRC-026. However, in the broader sense, the CAP for PRC-026-1 is specifically intended to ensure that load-responsive protective relays are expected to not trip in response to stable power swings during non-Fault conditions and PRC-004 is to identify and correct the causes of Misoperations of Protection Systems for Bulk Electric System (BES) Elements. In most cases, action required for each standard will remain separate and distinct whether included in one CAP or separate CAPs.</p> <p>Concerns could exist for electromechanical relays. Electromechanical relays do not provide appropriate data to verify operation or misoperation due to a stable or unstable power swing. Electromechanical relays can only provide target data. To verify correct operation due to a stable or unstable power swing, plots of the system impedance characteristic need to be obtained. Suggest that requirement 2.3 be added clearly identifying that limited data where it isn't possible to verify if a relay tripped due to a power swing, the entity can conclude it is unaware of the trip cause and a PRC-026 report isn't required or use of a foot note could be added.</p> <p><b>Response:</b> Issues concerning the ability of an entity being capable of identifying power swings is addressed by the "becoming aware" language in Requirement R2, Part 2.2. See the Guidelines and Technical Basis as footnoted in the revised standard for "becoming aware." Performance under Requirement R2, Part 2.2 starts with becoming aware of the event (i.e., power swing) and then any connection with the entity's Element tripping. No change made.</p>
<p>Modesto Irrigation District</p>	<p>The standard should be applicable to more than just BES elements.</p> <p>I think it is critical that the following phrase be included in Part 4.2 of the Applicability Section: "Any system element, regardless of size or connected voltage, that has been shown to be material to the reliability of the BES". The "bright line" of 100 kV is fine in general, but when it is known that an element connected at less than 100 kV is material to the reliability of the BES, it should be included as an applicable facility for this standard.</p> <p>This is because WECC members have learned over the years to recognize the significant role that smaller size elements play in system response and stability. Also, past WECC studies of major outages have shown that elements connected at less than 100 kV, have played a major role in the impact of outages. In fact, the most accurate duplication of the 1996 major system wide outage and more recent outages that the WECC</p>



Organization	Question 1 Comment
	<p>MVWG has simulated, have shown that the accuracy of the simulated results of actual system outages is highly affected by the accuracy of the modeled system below 100 KV.</p> <p><b>Response:</b> The standard drafting team thanks you for your comment. The standard addresses concerns raised in the Federal Energy Regulatory Order No. 733 using an equally effective and efficient approach based on the PSRPS Report.<sup>12</sup> The standard uses the PSRPS Report’s narrow focus for the applicability to the subset of BES Elements that are at an increased risk for power swings. By identifying these specific BES Elements, the Generator Owner and Transmission Owner can ensure that load-responsive protective relays are expected to not trip in response to stable power swings during non-Fault conditions. Entities are not precluded from applying the principles to other BES and non-BES Elements. No change made.</p>
<p>PPL NERC Registered Affiliates</p>	<p>These comments are submitted on behalf of the following PPL NERC Registered Affiliates: LG&amp;E and KU Energy, LLC; PPL Electric Utilities Corporation, PPL EnergyPlus, LLC; PPL Generation, LLC; PPL Susquehanna, LLC; and PPL Montana, LLC. The PPL NERC Registered Affiliates are registered in six regions (MRO, NPCC, RFC, SERC, SPP, and WECC) for one or more of the following NERC functions: BA, DP, GO, GOP, IA, LSE, PA, PSE, RP, TO, TOP, TP, and TSP.</p> <p>Comments: We agree that SDT has largely addressed industry comments on this standard and believe that STD’s work on this standard sets a model for future collaborative effort. We have only one remaining concern. Although the Application Guideline has language that satisfactorily explains the intent of the “becoming aware of” language in subpart 2.2, we are concerned that a guideline is not enforceable. We recommend adding a footnote in subpart 2.2 that solidly ties the guideline language to this subpart. If this single change were made to this version of the standard, PPL would vote affirmatively.</p> <p><b>Response:</b> The standard drafting team agrees that placing a cross reference in a footnote to the guidelines will provide increased awareness of where examples can be found. A reference to the Guidelines and Technical Basis concerning “becoming aware” footnote has been appended to Requirement R2, Part 2.2. However, the addition of the footnote only serves to increase the visibility of where an entity can find examples. It does not make the information in the guideline part of the enforceable requirement.</p>

<sup>12</sup> NERC System Protection and Control Subcommittee, *Protection System Response to Power Swings*, August 2013: [http://www.nerc.com/comm/PC/System%20Protection%20and%20Control%20Subcommittee%20SPCS%2020/SPCS%20Power%20Swing%20Report\\_Final\\_20131015.pdf](http://www.nerc.com/comm/PC/System%20Protection%20and%20Control%20Subcommittee%20SPCS%2020/SPCS%20Power%20Swing%20Report_Final_20131015.pdf)

Organization	Question 1 Comment
<p>Tri-State Generation and Transmission Association, Inc.</p>	<p>Tri-State believes that Requirement R3 should continue to refer to the Requirement to assess the load-responsive protective relays against the criteria of PRC-026-1 - Attachment B. We recommend adding “pursuant to Requirement R2,” between “PRC-026-1 - Attachment B criteria,” and “develop a Corrective Action Plan (CAP)” in Requirement R3. Without the clarifying clause, the requirement could be referring to any load-responsive protective relay that the entity happens to recognize that does not meet the criteria in the attachment.</p> <p><b>Response:</b> The standard drafting team agrees with the suggestion that it adds clarity that Requirement R3 in contingent upon Requirement R2. Clarification made.</p>
<p>JEA</p>	<p>We are concerned that this standard may have unintended consequences and hurt the reliability of the BES.</p> <p><b>Response:</b> The standard drafting team thanks you for your comment.</p>
<p>SPP Standards Review Group</p>	<p>We have a concern about the significance of Attachment A in the documentation and ask the drafting team to provide more clarity on this documentation.</p> <p>In Requirement R3, the drafting team mentions that the Generator Owner and Transmission Owner has six full calendar months after determining that load-responsive protection relays don’t meet Attachment B criteria and a Correction Action Plan (CAP) needs to be developed. Additionally in the second bullet of the same requirement, the drafting team mentions ‘The Protection System is excluded under the PRC-026-1 - Attachment A criteria’. However in the Rationale Box of R3, the drafting team provides detailed information on the necessity of the CAP and its association with Attachment B. As for Attachment A, there is no explanation of how it impacts the Generator Owner and Transmission Owner or what role it plays in this process. Please provide more detailed information in the Rationale Box of R3 in reference to Attachment A.</p> <p><b>Response:</b> The standard drafting team notes that the rationale box incorrectly referenced Requirement R2 and should have been Requirement R3. The rationale box was revised to provide information about PRC-026-1 – Attachment A. For a load-responsive protective relay that did not meet the PRC-026-1 –</p>

Organization	Question 1 Comment
	<p>Attachment B criteria, the entity must develop a Corrective Action Plan (CAP) meets one of the following (the following is paraphrased for clarity):</p> <ol style="list-style-type: none"> <li>1. Modify the Protection System to meet PRC-026-1 – Attachment B criteria or make some other modification (e.g., a system configuration change) such that the Protection System will meet PRC-026-1 – Attachment B criteria (because the system impedance changed), or</li> <li>2. Modify the Protection System in a manner as to exclude it from the applicability of the standard (by using the list of exclusions in PRC-026-1 – Attachment A). For example, applying power swing blocking supervision to the load-responsive protective relay would be an acceptable CAP and way to meet the objectives of the Standard.</li> </ol>
<p>Northeast Power Coordinating Council</p>	<p>With respect to Requirement 1, stability addressed by RAS (Criterion 1), or relay trips observed in Planning Assessments (Criterion 4) often involves remote or local generators and the instability or relay trip does not impact the Bulk Electric System outside the local area. In NPCC, the majority of RAS are classified as Type III SPS, meaning that their failure (and resulting instability) does not adversely impact the Bulk Electric System outside the local area. As in PRC-010-1 that recognizes local issues and "provides latitude for the Planning Coordinator or Transmission Planner to determine if UVLS falls under the defined term based on the impact on the reliability of the BES", it is suggested that PRC-026-1 also provide latitude to the PC to exclude some of the BES Elements identified by Criteria 1 and 4 if the instability or relay trip does not impact the Bulk Electric System outside the local area.</p> <p><b>Response:</b> The standard drafting team has developed the standard consistent with applicability provided in the PSRPS Report.<sup>13</sup> All of the BES Elements that are identified through the Requirements must meet the standard regardless of whether the condition is a local issue or a more widespread problem. No change made.</p> <p>The page numbers refer to the pages in the clean copy of PRC-026-1.</p>

<sup>13</sup> NERC System Protection and Control Subcommittee, *Protection System Response to Power Swings*, August 2013: [http://www.nerc.com/comm/PC/System%20Protection%20and%20Control%20Subcommittee%20SPCS%2020/SPCS%20Power%20Swing%20Report\\_Final\\_20131015.pdf](http://www.nerc.com/comm/PC/System%20Protection%20and%20Control%20Subcommittee%20SPCS%2020/SPCS%20Power%20Swing%20Report_Final_20131015.pdf)

Organization	Question 1 Comment
	<p>Page 14--from "The following protection functions are excluded from Requirements of this standard:", Why are voltage-restrained relays excluded? Wouldn't the voltage dip during a power swing enable these relays to misoperate on load current?</p> <p><b>Response:</b> Voltage controlled time-overcurrent or voltage-restrained time-overcurrent relays are excluded from this standard. When set based on equipment permissible overload capability, a voltage-restrained time-overcurrent operating time is much greater than 15 cycles for the current levels observed during a power swing.</p> <p>Page 18--in the "Pole Slip:" item it should read "a generator's, or group of generator's, terminal...". Page 18--the "Out-of-step Condition:" should read "Same as an Unstable Power Swing." (Capitalization change).Page 20--line 5 should reads "...identified as BES Elements meeting...".</p> <p><b>Response:</b> These descriptions are taken directly from the referenced IEEE Power System Relaying Committee WG D6 developed a technical document called <i>Power Swing and Out-of-Step Considerations on Transmission Lines</i> (July 2005) technical document. No change made.</p> <p>Page 30--the caption for Figure 3 should read: "System impedances as seen by Relay R. (voltage connections for relay not shown.)"</p> <p><b>Response:</b> Correction made as suggested.</p> <p>Page 33-- The first blue box for Table 2 should read: "Positive sequence impedance data (with transfer impedance ZTR set to a very large value)."</p> <p><b>Response:</b> Clarification made.</p> <p>Page 33--In equation (8), ZTR was given as = <math>Z_L \times 10^{10}</math>, which equals <math>(4 + j20) \times 10^{10}</math>, not <math>(4 + j20)^{10}</math> as used in the equations.</p> <p><b>Response:</b> Correction made to all related equations.</p> <p>Page 34--In Table 3, the second blue box should read: "Positive sequence impedance data (with transfer impedance ZTR set to a very large value).</p> <p><b>Response:</b> Clarification made.</p>

Organization	Question 1 Comment
	<p>Page 36--same comment for Equation (16) as for Equation (8) above.  <b>Response:</b> Correction made to all related equations.</p> <p>Page 36--for Table 4 and Equation (24), the same comment as for Equation (8) above.  <b>Response:</b> Correction made to all related equations.</p> <p>Pages 38-42--for Tables 5, 6, and 7 the same comment as for Equation (8) above.  <b>Response:</b> Correction made to all related equations.</p> <p>Page 53--For Figure 12 the caption should be rephrased to: "The tripping portion of the mho element characteristic not blocked by load encroachment (i.e., ...) is completely contained within...".  <b>Response:</b> Clarification made.</p> <p>Page 69--The last blue box in Table 14 should read "Total system current". Current direction is irrelevant.  <b>Response:</b> The phrase "from sending-end source" was deleted.</p> <p>Page 72--the Drafting Team should consider adding the word "Stable" in the lower right region of the Figure 16 graph, and the word "Unstable": under the words "Capability Curve" to the right of SSSL.  <b>Response:</b> Figure 16 illustrates a typical SSSL curve and is not intended to reference the stable and unstable regions as noted in other figures.</p> <p>Page 74--in Table 15, X'd was changed to X'd, but "sub-transient" was not corrected to read "saturated transient reactance".  <b>Response:</b> Correction made.</p> <p>Page 75--regarding Table 16, define the Base that the values of Table 15 have been converted to (e.g. "Table 16. Example calculations (Generator) on 941 MVA base").  <b>Response:</b> The MVA base was added to Table 16.</p> <p>Pages 74-75--there are two different values for Ze and both are in ohms, not per unit.</p>

Organization	Question 1 Comment
	<p><b>Response:</b> Values were updated to reference per unit and <math>Z_e</math> was corrected from 86 degrees to 90 degrees to be consistent.</p> <p>Page 75--in Equation (107) <math>j0.3845 + j0.171 + 0.06796</math> does is not equal to <math>0.6239\angle 90\Omega</math>.</p> <p><b>Response:</b> Correction made.</p> <p>Page 75-- <math>Z_{sys}</math> is defined as <math>0.6239\angle 90\Omega</math> in Equation (107) of Table 16, but defined as <math>0.6234\angle 90\Omega</math> in Equation (109) of Table 16 and in Equation (110) of the Instantaneous Overcurrent Relay section.</p> <p><b>Response:</b> Correction made to Equation 107 and Equations 109 and 110 are now correct.</p> <p>Page 78--in Figure 20 add “hashing” to the area between the SSSL (black) curve and the 40-1 (blue) curve with an arrow and note saying “Stable and can trip” or similar wording.</p> <p><b>Response:</b> Figure 20 title was revised to remove the reference to “stable power swing” and to note the figure is a typical loss-of-field R-X plot. Hashing relative to the SSSL curve was not added because the figure is illustrating a test against the unstable power swing region represented by the solid red lines.</p> <p>There are inconsistencies in the use of “per unit” in the tables of the Applications Guidelines. In some instances per unit is used, and in other instances the ohmic value is given. There should be consistency in the Applications Guidelines and standard.</p> <p><b>Response:</b> The standard drafting team revised the calculations so that per unit and ohm values are consistent within each table.</p>

**END OF REPORT**

## Standard Development Timeline

---

*This section is maintained by the drafting team during the development of the standard and will be removed when the standard becomes effective.*

### Development Steps Completed

1. Standards Authorization Request (SAR) posted for comment from August 19, 2010, through September 19, 2010.
2. Standards Committee (SC) authorized moving the SAR forward into standard development on August 12, 2010.
3. SC authorized initial posting of Draft 1 on April 24, 2014.
4. Draft 1 of PRC-026-1 was posted for a 45-day formal comment period from April 25 – June 9, 2014, with a concurrent/parallel initial ballot in the last ten days of the comment period from May 30 – June 9, 2014.
5. Draft 2 of PRC-026-1 was posted for an additional 45-day formal comment period from August 22 – October 6, 2014 with a concurrent/parallel additional ballot in the last ten days of the comment period from September 26 – October 6, 2014.
6. SC authorized a waiver of the Standards Process Manual on October 22, 2014 to reduce the Draft 3 additional formal comment period of PRC-026-1 from 45 days to 21 days with a concurrent/additional ballot period in the last ten days of the comment period.
7. Draft 3 of PRC-026-1 was posted for an additional 21-day formal comment period from November 4 – November 24, 2014 with a concurrent/parallel additional ballot in the last ten days of the comment period from November 14 – November 24, 2014

### Description of Current Draft

The Protection System Response to Power Swings Standard Drafting Team (PSRPS SDT) is posting Draft 4 of PRC-026-1 – Relay Performance During Stable Power Swings for a 10-day final ballot.

Anticipated Actions	Anticipated Date
45-day Formal Comment Period with Concurrent/Parallel Initial 10-day Ballot	April 2014
45-day Formal Comment Period with Concurrent/Parallel Additional 10-day Ballot	August 2014

Anticipated Actions	Anticipated Date
21-day Formal Comment Period with Concurrent/Parallel Additional 10-day Ballot (Standards Committee authorized a waiver of the Standards Process Manual, October 22, 2014)	November 2014
Final Ballot	December 2014
NERC Board of Trustees Adoption	December 2014

**Version History**

Version	Date	Action	Change Tracking
1.0	TBD	Effective Date	New



### **Definitions of Terms Used in Standard**

*This section includes all newly defined or revised terms used in the proposed standard. Terms already defined in the Glossary of Terms Used in Reliability Standards (Glossary) are not repeated here. New or revised definitions listed below become approved when the proposed standard is approved. When the standard becomes effective, these defined terms will be removed from the individual standard and added to the Glossary.*

**Term:** None.

*When this standard has received ballot approval, the rationale boxes will be moved to the Application Guidelines Section of the standard.*

## **A. Introduction**

- 1. Title:** Relay Performance During Stable Power Swings
- 2. Number:** PRC-026-1
- 3. Purpose:** To ensure that load-responsive protective relays are expected to not trip in response to stable power swings during non-Fault conditions.
- 4. Applicability:**
  - 4.1. Functional Entities:**
    - 4.1.1** Generator Owner that applies load-responsive protective relays as described in PRC-026-1 – Attachment A at the terminals of the Elements listed in Section 4.2, Facilities.
    - 4.1.2** Planning Coordinator.
    - 4.1.3** Transmission Owner that applies load-responsive protective relays as described in PRC-026-1 – Attachment A at the terminals of the Elements listed in Section 4.2, Facilities.
  - 4.2. Facilities:** The following Elements that are part of the Bulk Electric System (BES):
    - 4.2.1** Generators.
    - 4.2.2** Transformers.
    - 4.2.3** Transmission lines.

## **5. Background:**

This is the third phase of a three-phased standard development project that focused on developing this new Reliability Standard to address protective relay operations due to stable power swings. The March 18, 2010, Federal Energy Regulatory Commission (FERC) Order No. 733 approved Reliability Standard PRC-023-1 – Transmission Relay Loadability. In that Order, FERC directed NERC to address three areas of relay loadability that include modifications to the approved PRC-023-1, development of a new Reliability Standard to address generator protective relay loadability, and a new Reliability Standard to address the operation of protective relays due to stable power swings. This project's SAR addresses these directives with a three-phased approach to standard development.

Phase 1 focused on making the specific modifications from FERC Order No. 733 to PRC-023-1. Reliability Standard PRC-023-2, which incorporated these modifications, became mandatory on July 1, 2012.

Phase 2 focused on developing a new Reliability Standard, PRC-025-1 – Generator Relay Loadability, to address generator protective relay loadability. PRC-025-1 became mandatory on October 1, 2014, along with PRC-023-3, which was modified to harmonize PRC-023-2 with PRC-025-1.

Phase 3 focuses on preventing protective relays from tripping unnecessarily due to stable power swings by requiring identification of Elements on which a stable or unstable power swing may affect Protection System operation, assessment of the security of load-responsive protective relays to tripping in response to only a stable power swing, and implementation of Corrective Action Plans (CAP), where necessary. Phase 3 improves security of load-responsive protective relays for stable power swings so they are expected to not trip in response to stable power swings during non-Fault conditions while maintaining dependable fault detection and dependable out-of-step tripping.

**6. Effective Dates:**

**Requirement R1**

First day of the first full calendar year that is 12 months after the date that the standard is approved by an applicable governmental authority or as otherwise provided for in a jurisdiction where approval by an applicable governmental authority is required for a standard to go into effect. Where approval by an applicable governmental authority is not required, the standard shall become effective on the first day of the first full calendar year that is 12 months after the date the standard is adopted by the NERC Board of Trustees or as otherwise provided for in that jurisdiction.

**Requirements R2, R3, and R4**

First day of the first full calendar year that is 36 months after the date that the standard is approved by an applicable governmental authority or as otherwise provided for in a jurisdiction where approval by an applicable governmental authority is required for a standard to go into effect. Where approval by an applicable governmental authority is not required, the standard shall become effective on the first day of the first full calendar year that is 36 months after the date the standard is adopted by the NERC Board of Trustees or as otherwise provided for in that jurisdiction.

## B. Requirements and Measures

**R1.** Each Planning Coordinator shall, at least once each calendar year, provide notification of each generator, transformer, and transmission line BES Element in its area that meets one or more of the following criteria, if any, to the respective Generator Owner and Transmission Owner: [*Violation Risk Factor: Medium*] [*Time Horizon: Long-term Planning*]

Criteria:

1. Generator(s) where an angular stability constraint exists that is addressed by a System Operating Limit (SOL) or a Remedial Action Scheme (RAS) and those Elements terminating at the Transmission station associated with the generator(s).
  2. An Element that is monitored as part of an SOL identified by the Planning Coordinator's methodology<sup>1</sup> based on an angular stability constraint.
  3. An Element that forms the boundary of an island in the most recent underfrequency load shedding (UFLS) design assessment based on application of the Planning Coordinator's criteria for identifying islands, only if the island is formed by tripping the Element due to angular instability.
  4. An Element identified in the most recent annual Planning Assessment where relay tripping occurs due to a stable or unstable<sup>2</sup> power swing during a simulated disturbance.
- M1.** Each Planning Coordinator shall have dated evidence that demonstrates notification of the generator, transformer, and transmission line BES Element(s) that meet one or more of the criteria in Requirement R1, if any, to the respective Generator Owner and Transmission Owner. Evidence may include, but is not limited to, the following documentation: emails, facsimiles, records, reports, transmittals, lists, or spreadsheets.

**Rationale for R1:** The Planning Coordinator has a wide-area view and is in the position to identify generator, transformer, and transmission line BES Elements which meet the criteria, if any. The criteria-based approach is consistent with the NERC System Protection and Control Subcommittee (SPCS) technical document *Protection System Response to Power Swings*, August 2013 ("PSRPS Report"),<sup>3</sup> which recommends a focused approach to determine an at-risk BES Element. See the Guidelines and Technical Basis for a detailed discussion of the criteria.

---

<sup>1</sup> NERC Reliability Standard FAC-014-2 – Establish and Communicate System Operating Limits, Requirement R3.

<sup>2</sup> An example of an unstable power swing is provided in the Guidelines and Technical Basis section, "Justification for Including Unstable Power Swings in the Requirements section of the Guidelines and Technical Basis."

<sup>3</sup> NERC System Protection and Control Subcommittee, *Protection System Response to Power Swings*, August 2013: [http://www.nerc.com/comm/PC/System%20Protection%20and%20Control%20Subcommittee%20SPCS%2020/SPCS%20Power%20Swing%20Report\\_Final\\_20131015.pdf](http://www.nerc.com/comm/PC/System%20Protection%20and%20Control%20Subcommittee%20SPCS%2020/SPCS%20Power%20Swing%20Report_Final_20131015.pdf)

- R2.** Each Generator Owner and Transmission Owner shall: [Violation Risk Factor: High]  
[Time Horizon: Operations Planning]
- 2.1** Within 12 full calendar months of notification of a BES Element pursuant to Requirement R1, determine whether its load-responsive protective relay(s) applied to that BES Element meets the criteria in PRC-026-1 – Attachment B where an evaluation of that Element’s load-responsive protective relay(s) based on PRC-026-1 – Attachment B criteria has not been performed in the last five calendar years.
- 2.2** Within 12 full calendar months of becoming aware<sup>4</sup> of a generator, transformer, or transmission line BES Element that tripped in response to a stable or unstable<sup>5</sup> power swing due to the operation of its protective relay(s), determine whether its load-responsive protective relay(s) applied to that BES Element meets the criteria in PRC-026-1 – Attachment B.
- M2.** Each Generator Owner and Transmission Owner shall have dated evidence that demonstrates the evaluation was performed according to Requirement R2. Evidence may include, but is not limited to, the following documentation: apparent impedance characteristic plots, email, design drawings, facsimiles, R-X plots, software output, records, reports, transmittals, lists, settings sheets, or spreadsheets.

**Rationale for R2:** The Generator Owner and Transmission Owner are in a position to determine whether their load-responsive protective relays meet the PRC-026-1 – Attachment B criteria. Generator, transformer, and transmission line BES Elements are identified by the Planning Coordinator in Requirement R1 and by the Generator Owner and Transmission Owner following an actual event where the Generator Owner and Transmission Owner became aware (i.e., through an event analysis or Protection System review) tripping was due to a stable or unstable power swing. A period of 12 calendar months allows sufficient time for the entity to conduct the evaluation.

---

<sup>4</sup> Some examples of the ways an entity may become aware of a power swing are provided in the Guidelines and Technical Basis section, “Becoming Aware of an Element That Tripped in Response to a Power Swing.”

<sup>5</sup> An example of an unstable power swing is provided in the Guidelines and Technical Basis section, “Justification for Including Unstable Power Swings in the Requirements section of the Guidelines and Technical Basis.”

- R3.** Each Generator Owner and Transmission Owner shall, within six full calendar months of determining a load-responsive protective relay does not meet the PRC-026-1 – Attachment B criteria pursuant to Requirement R2, develop a Corrective Action Plan (CAP) to meet one of the following: *[Violation Risk Factor: Medium] [Time Horizon: Operations Planning]*
- The Protection System meets the PRC-026-1 – Attachment B criteria, while maintaining dependable fault detection and dependable out-of-step tripping (if out-of-step tripping is applied at the terminal of the BES Element); or
  - The Protection System is excluded under the PRC-026-1 – Attachment A criteria (e.g., modifying the Protection System so that relay functions are supervised by power swing blocking or using relay systems that are immune to power swings), while maintaining dependable fault detection and dependable out-of-step tripping (if out-of-step tripping is applied at the terminal of the BES Element).
- M3.** The Generator Owner and Transmission Owner shall have dated evidence that demonstrates the development of a CAP in accordance with Requirement R3. Evidence may include, but is not limited to, the following documentation: corrective action plans, maintenance records, settings sheets, project or work management program records, or work orders.

**Rationale for R3:** To meet the reliability purpose of the standard, a CAP is necessary to ensure the entity’s Protection System meets the PRC-026-1 – Attachment B criteria (1<sup>st</sup> bullet) so that protective relays are expected to not trip in response to stable power swings. A CAP may also be developed to modify the Protection System for exclusion under PRC-026-1 – Attachment A (2<sup>nd</sup> bullet). Such an exclusion will allow the Protection System to be exempt from the Requirement for future events. The phrase, “...while maintaining dependable fault detection and dependable out-of-step tripping...” in Requirement R3 describes that the entity is to comply with this standard, while achieving their desired protection goals. Refer to the Guidelines and Technical Basis, Introduction, for more information.

- R4.** Each Generator Owner and Transmission Owner shall implement each CAP developed pursuant to Requirement R3 and update each CAP if actions or timetables change until all actions are complete. *[Violation Risk Factor: Medium][Time Horizon: Long-Term Planning]*
- M4.** The Generator Owner and Transmission Owner shall have dated evidence that demonstrates implementation of each CAP according to Requirement R4, including updates to the CAP when actions or timetables change. Evidence may include, but is not limited to, the following documentation: corrective action plans, maintenance records, settings sheets, project or work management program records, or work orders.

**Rationale for R4:** Implementation of the CAP must accomplish all identified actions to be complete to achieve the desired reliability goal. During the course of implementing a CAP, updates may be necessary for a variety of reasons such as new information, scheduling conflicts, or resource issues. Documenting CAP changes and completion of activities provides measurable progress and confirmation of completion.

## C. Compliance

### 1. Compliance Monitoring Process

#### 1.1. Compliance Enforcement Authority

As defined in the NERC Rules of Procedure, “Compliance Enforcement Authority” (CEA) means NERC or the Regional Entity in their respective roles of monitoring and enforcing compliance with the NERC Reliability Standards.

#### 1.2. Evidence Retention

The following evidence retention periods identify the period of time an entity is required to retain specific evidence to demonstrate compliance. For instances where the evidence retention period specified below is shorter than the time since the last audit, the CEA may ask an entity to provide other evidence to show that it was compliant for the full time period since the last audit.

The Generator Owner, Planning Coordinator, and Transmission Owner shall keep data or evidence to show compliance as identified below unless directed by its CEA to retain specific evidence for a longer period of time as part of an investigation.

- The Planning Coordinator shall retain evidence of Requirement R1 for a minimum of one calendar year following the completion of the Requirement.
- The Generator Owner and Transmission Owner shall retain evidence of Requirement R2 evaluation for a minimum of 12 calendar months following completion of each evaluation where a CAP is not developed.
- The Generator Owner and Transmission Owner shall retain evidence of Requirements R2, R3, and R4 for a minimum of 12 calendar months following completion of each CAP.

If a Generator Owner, Planning Coordinator, or Transmission Owner is found non-compliant, it shall keep information related to the non-compliance until mitigation is complete and approved, or for the time specified above, whichever is longer.

The CEA shall keep the last audit records and all requested and submitted subsequent audit records.

**1.3. Compliance Monitoring and Assessment Processes:**

As defined in the NERC Rules of Procedure; “Compliance Monitoring and Assessment Processes” refers to the identification of the processes that will be used to evaluate data or information for the purpose of assessing performance or outcomes with the associated reliability standard.

**1.4. Additional Compliance Information**

None.



Table of Compliance Elements

R#	Time Horizon	VRF	Violation Severity Levels			
			Lower VSL	Moderate VSL	High VSL	Severe VSL
R1	Long-term Planning	Medium	The Planning Coordinator provided notification of the BES Element(s) in accordance with Requirement R1, but was less than or equal to 30 calendar days late.	The Planning Coordinator provided notification of the BES Element(s) in accordance with Requirement R1, but was more than 30 calendar days and less than or equal to 60 calendar days late.	The Planning Coordinator provided notification of the BES Element(s) in accordance with Requirement R1, but was more than 60 calendar days and less than or equal to 90 calendar days late.	The Planning Coordinator provided notification of the BES Element(s) in accordance with Requirement R1, but was more than 90 calendar days late.  OR  The Planning Coordinator failed to provide notification of the BES Element(s) in accordance with Requirement R1.

R#	Time Horizon	VRF	Violation Severity Levels			
			Lower VSL	Moderate VSL	High VSL	Severe VSL
<b>R2</b>	Operations Planning	High	The Generator Owner or Transmission Owner evaluated its load-responsive protective relay(s) in accordance with Requirement R2, but was less than or equal to 30 calendar days late.	The Generator Owner or Transmission Owner evaluated its load-responsive protective relay(s) in accordance with Requirement R2, but was more than 30 calendar days and less than or equal to 60 calendar days late.	The Generator Owner or Transmission Owner evaluated its load-responsive protective relay(s) in accordance with Requirement R2, but was more than 60 calendar days and less than or equal to 90 calendar days late.	The Generator Owner or Transmission Owner evaluated its load-responsive protective relay(s) in accordance with Requirement R2, but was more than 90 calendar days late.  OR The Generator Owner or Transmission Owner failed to evaluate its load-responsive protective relay(s) in accordance with Requirement R2.

R#	Time Horizon	VRF	Violation Severity Levels			
			Lower VSL	Moderate VSL	High VSL	Severe VSL
<b>R3</b>	Long-term Planning	Medium	The Generator Owner or Transmission Owner developed a Corrective Action Plan (CAP) in accordance with Requirement R3, but in more than six calendar months and less than or equal to seven calendar months.	The Generator Owner or Transmission Owner developed a Corrective Action Plan (CAP) in accordance with Requirement R3, but in more than seven calendar months and less than or equal to eight calendar months.	The Generator Owner or Transmission Owner developed a Corrective Action Plan (CAP) in accordance with Requirement R3, but in more than eight calendar months and less than or equal to nine calendar months.	The Generator Owner or Transmission Owner developed a Corrective Action Plan (CAP) in accordance with Requirement R3, but in more than nine calendar months.  OR The Generator Owner or Transmission Owner failed to develop a CAP in accordance with Requirement R3.
<b>R4</b>	Long-term Planning	Medium	The Generator Owner or Transmission Owner implemented a Corrective Action Plan (CAP), but failed to update a CAP when actions or timetables changed, in accordance with Requirement R4.	N/A	N/A	The Generator Owner or Transmission Owner failed to implement a Corrective Action Plan (CAP) in accordance with Requirement R4.

#### D. Regional Variances

None.

#### E. Interpretations

None.

#### F. Associated Documents

*Applied Protective Relaying*, Westinghouse Electric Corporation, 1979.

Burdy, John, *Loss-of-excitation Protection for Synchronous Generators GER-3183*, General Electric Company.

IEEE Power System Relaying Committee WG D6, *Power Swing and Out-of-Step Considerations on Transmission Lines*, July 2005: <http://www.pes-psrc.org/Reports/Power%20Swing%20and%20OOS%20Considerations%20on%20Transmission%20Lines%20F..pdf>.

Kimbark Edward Wilson, *Power System Stability, Volume II: Power Circuit Breakers and Protective Relays*, Published by John Wiley and Sons, 1950.

Kundur, Prabha, *Power System Stability and Control*, 1994, Palo Alto: EPRI, McGraw Hill, Inc.

NERC System Protection and Control Subcommittee, *Protection System Response to Power Swings*, August 2013: [http://www.nerc.com/comm/PC/System%20Protection%20and%20Control%20Subcommittee%20SPCS%2020/SPCS%20Power%20Swing%20Report\\_Final\\_20131015.pdf](http://www.nerc.com/comm/PC/System%20Protection%20and%20Control%20Subcommittee%20SPCS%2020/SPCS%20Power%20Swing%20Report_Final_20131015.pdf).

Reimert, Donald, *Protective Relaying for Power Generation Systems*, 2006, Boca Raton: CRC Press.

**PRC-026-1 – Attachment A**

This standard applies to any protective functions which could trip instantaneously or with a time delay of less than 15 cycles on load current (i.e., “load-responsive”) including, but not limited to:

- Phase distance
- Phase overcurrent
- Out-of-step tripping
- Loss-of-field

The following protection functions are excluded from Requirements of this standard:

- Relay elements supervised by power swing blocking
- Relay elements that are only enabled when other relays or associated systems fail. For example:
  - Overcurrent elements that are only enabled during loss of potential conditions.
  - Relay elements that are only enabled during a loss of communications
- Thermal emulation relays which are used in conjunction with dynamic Facility Ratings
- Relay elements associated with direct current (dc) lines
- Relay elements associated with dc converter transformers
- Phase fault detector relay elements employed to supervise other load-responsive phase distance elements (i.e., in order to prevent false operation in the event of a loss of potential)
- Relay elements associated with switch-onto-fault schemes
- Reverse power relay on the generator
- Generator relay elements that are armed only when the generator is disconnected from the system, (e.g., non-directional overcurrent elements used in conjunction with inadvertent energization schemes, and open breaker flashover schemes)
- Current differential relay, pilot wire relay, and phase comparison relay
- Voltage-restrained or voltage-controlled overcurrent relays

PRC-026-1 – Attachment B

Criterion A:

An impedance-based relay used for tripping is expected to not trip for a stable power swing, when the relay characteristic is completely contained within the unstable power swing region.<sup>6</sup> The unstable power swing region is formed by the union of three shapes in the impedance (R-X) plane; (1) a lower loss-of-synchronism circle based on a ratio of the sending-end to receiving-end voltages of 0.7; (2) an upper loss-of-synchronism circle based on a ratio of the sending-end to receiving-end voltages of 1.43; (3) a lens that connects the endpoints of the total system impedance (with the parallel transfer impedance removed) bounded by varying the sending-end and receiving-end voltages from 0.0 to 1.0 per unit, while maintaining a constant system separation angle across the total system impedance where:

1. The system separation angle is:
  - At least 120 degrees, or
  - An angle less than 120 degrees where a documented transient stability analysis demonstrates that the expected maximum stable separation angle is less than 120 degrees.
2. All generation is in service and all transmission BES Elements are in their normal operating state when calculating the system impedance.
3. Saturated (transient or sub-transient) reactance is used for all machines.

**Rationale for Attachment B (Criterion A):** The PRC-026-1 – Attachment B, Criterion A provides a basis for determining if the relays are expected to not trip for a stable power swing having a system separation angle of up to 120 degrees with the sending-end and receiving-end voltages varying from 0.7 to 1.0 per unit (See Guidelines and Technical Basis).

---

<sup>6</sup> Guidelines and Technical Basis, Figures 1 and 2.

**PRC-026-1 – Attachment B**

Criterion B:

The pickup of an overcurrent relay element used for tripping, that is above the calculated current value (with the parallel transfer impedance removed) for the conditions below:

1. The system separation angle is:
  - At least 120 degrees, or
  - An angle less than 120 degrees where a documented transient stability analysis demonstrates that the expected maximum stable separation angle is less than 120 degrees.
2. All generation is in service and all transmission BES Elements are in their normal operating state when calculating the system impedance.
3. Saturated (transient or sub-transient) reactance is used for all machines.
4. Both the sending-end and receiving-end voltages at 1.05 per unit.

**Rationale for Attachment B (Criterion B):** The PRC-026-1 – Attachment B, Criterion B provides a basis for determining if the relays are expected to not trip for a stable power swing having a system separation angle of up to 120 degrees with the sending-end and receiving-end voltages at 1.05 per unit (See Guidelines and Technical Basis).

### Guidelines and Technical Basis

#### Introduction

The NERC System Protection and Control Subcommittee technical document, *Protection System Response to Power Swings*, August 2013,<sup>7</sup> (“PSRPS Report” or “report”) was specifically prepared to support the development of this NERC Reliability Standard. The report provided a historical perspective on power swings as early as 1965 up through the approval of the report by the NERC Planning Committee. The report also addresses reliability issues regarding trade-offs between security and dependability of Protection Systems, considerations for this NERC Reliability Standard, and a collection of technical information about power swing characteristics and varying issues with practical applications and approaches to power swings. Of these topics, the report suggests an approach for this NERC Reliability Standard (“standard” or “PRC-026-1”) which is consistent with addressing three regulatory directives in the FERC Order No. 733. The first directive concerns the need for “...protective relay systems that differentiate between faults and stable power swings and, when necessary, phases out protective relay systems that cannot meet this requirement.”<sup>8</sup> Second, is “...to develop a Reliability Standard addressing undesirable relay operation due to stable power swings.”<sup>9</sup> The third directive “...to consider “islanding” strategies that achieve the fundamental performance for all islands in developing the new Reliability Standard addressing stable power swings”<sup>10</sup> was considered during development of the standard.

The development of this standard implements the majority of the approaches suggested by the report. However, it is noted that the Reliability Coordinator and Transmission Planner have not been included in the standard’s Applicability section (as suggested by the PSRPS Report). This is so that a single entity, the Planning Coordinator, may be the single source for identifying Elements according to Requirement R1. A single source will insure that multiple entities will not identify Elements in duplicate, nor will one entity fail to provide an Element because it believes the Element is being provided by another entity. The Planning Coordinator has, or has access to, the wide-area model and can correctly identify the Elements that may be susceptible to a stable or unstable power swing. Additionally, not including the Reliability Coordinator and Transmission Planner is consistent with the applicability of other relay loadability NERC Reliability Standards (e.g., PRC-023 and PRC-025). It is also consistent with the NERC Functional Model.

The phrase, “while maintaining dependable fault detection and dependable out-of-step tripping” in Requirement R3, describes that the Generator Owner and Transmission Owner are to comply with this standard while achieving its desired protection goals. Load-responsive protective relays, as addressed within this standard, may be intended to provide a variety of backup protection functions, both within the generating unit or generating plant and on the transmission system, and

---

<sup>7</sup> NERC System Protection and Control Subcommittee, *Protection System Response to Power Swings*, August 2013: [http://www.nerc.com/comm/PC/System%20Protection%20and%20Control%20Subcommittee%20SPCS%2020/SPCS%20Power%20Swing%20Report\\_Final\\_20131015.pdf](http://www.nerc.com/comm/PC/System%20Protection%20and%20Control%20Subcommittee%20SPCS%2020/SPCS%20Power%20Swing%20Report_Final_20131015.pdf)

<sup>8</sup> Transmission Relay Loadability Reliability Standard, Order No. 733, P.150 FERC ¶ 61,221 (2010).

<sup>9</sup> Ibid. P.153.

<sup>10</sup> Ibid. P.162.



this standard is not intended to result in the loss of these protection functions. Instead, the Generator Owner and Transmission Owner must consider both the Requirements within this standard and its desired protection goals and perform modifications to its protective relays or protection philosophies as necessary to achieve both.

### Power Swings

The IEEE Power System Relaying Committee WG D6 developed a technical document called *Power Swing and Out-of-Step Considerations on Transmission Lines* (July 2005) that provides background on power swings. The following are general definitions from that document:<sup>11</sup>

**Power Swing:** a variation in three phase power flow which occurs when the generator rotor angles are advancing or retarding relative to each other in response to changes in load magnitude and direction, line switching, loss of generation, faults, and other system disturbances.

**Pole Slip:** a condition whereby a generator, or group of generators, terminal voltage angles (or phases) go past 180 degrees with respect to the rest of the connected power system.

**Stable Power Swing:** a power swing is considered stable if the generators do not slip poles and the system reaches a new state of equilibrium, i.e. an acceptable operating condition.

**Unstable Power Swing:** a power swing that will result in a generator or group of generators experiencing pole slipping for which some corrective action must be taken.

**Out-of-Step Condition:** Same as an unstable power swing.

**Electrical System Center or Voltage Zero:** it is the point or points in the system where the voltage becomes zero during an unstable power swing.

### Burden to Entities

The PSRPS Report provides a technical basis and approach for focusing on Protection Systems, which are susceptible to power swings, while achieving the purpose of the standard. The approach reduces the number of relays to which the PRC-026-1 Requirements would apply by first identifying the BES Element(s) on which load-responsive protective relays must be evaluated. The first step uses criteria to identify the Elements on which a Protection System is expected to be challenged by power swings. Of those Elements, the second step is to evaluate each load-responsive protective relay that is applied on each identified Element. Rather than requiring the Planning Coordinator or Transmission Planner to perform simulations to obtain information for each identified Element, the Generator Owner and Transmission Owner will reduce the need for simulation by comparing the load-responsive protective relay characteristic to specific criteria in PRC-026-1 – Attachment B.

---

<sup>11</sup> <http://www.pes-psrc.org/Reports/Power%20Swing%20and%20OOS%20Considerations%20on%20Transmission%20Lines%20F..pdf>.

### Applicability

The standard is applicable to the Generator Owner, Planning Coordinator, and Transmission Owner entities. More specifically, the Generator Owner and Transmission Owner entities are applicable when applying load-responsive protective relays at the terminals of the applicable BES Elements. The standard is applicable to the following BES Elements: generators, transformers, and transmission lines. The Distribution Provider was considered for inclusion in the standard; however, it is not subject to the standard because this entity, by functional registration, would not own generators, transmission lines, or transformers other than load serving.

Load-responsive protective relays include any protective functions which could trip with or without time delay, on load current.

### Requirement R1

The Planning Coordinator has a wide-area view and is in the position to identify what, if any, Elements meet the criteria. The criterion-based approach is consistent with the NERC System Protection and Control Subcommittee (SPCS) technical document, *Protection System Response to Power Swings* (August 2013),<sup>12</sup> which recommends a focused approach to determine an at-risk Element. Identification of Elements comes from the annual Planning Assessments pursuant to the transmission planning (i.e., “TPL”) and other NERC Reliability Standards (e.g., PRC-006), and the standard is not requiring any other assessments to be performed by the Planning Coordinator. The required notification on a calendar year basis to the respective Generator Owner and Transmission Owner is sufficient because it is expected that the Planning Coordinator will make its notifications following the completion of its annual Planning Assessments. The Planning Coordinator will continue to provide notification of Elements on a calendar year basis even if a study is performed less frequently (e.g., PRC-006 – Automatic Underfrequency Load Shedding, which is five years) and has not changed. It is possible that a Planning Coordinator could utilize studies from a prior year in determining the necessary notifications pursuant to Requirement R1.

### Criterion 1

The first criterion involves generator(s) where an angular stability constraint exists that is addressed by a System Operating Limit (SOL) or a Remedial Action Scheme (RAS) and those Elements terminating at the Transmission station associated with the generator(s). For example, a scheme to remove generation for specific conditions is implemented for a four-unit generating plant (1,100 MW). Two of the units are 500 MW each; one is connected to the 345 kV system and one is connected to the 230 kV system. The Transmission Owner has two 230 kV transmission lines and one 345 kV transmission line all terminating at the generating facility as well as a 345/230 kV autotransformer. The remaining 100 MW consists of two 50 MW combustion turbine (CT) units connected to four 66 kV transmission lines. The 66 kV transmission lines are not electrically joined to the 345 kV and 230 kV transmission lines at the plant site and are not subject to the operating limit or RAS. A stability constraint limits the output of the portion of the plant affected

---

<sup>12</sup> [http://www.nerc.com/comm/PC/System%20Protection%20and%20Control%20Subcommittee%20SPCS%2020/SPCS%20Power%20Swing%20Report\\_Final\\_20131015.pdf](http://www.nerc.com/comm/PC/System%20Protection%20and%20Control%20Subcommittee%20SPCS%2020/SPCS%20Power%20Swing%20Report_Final_20131015.pdf)

by the RAS to 700 MW for an outage of the 345 kV transmission line. The RAS trips one of the 500 MW units to maintain stability for a loss of the 345 kV transmission line when the total output from both 500 MW units is above 700 MW. For this example, both 500 MW generating units and the associated generator step-up (GSU) transformers would be identified as Elements meeting this criterion. The 345/230 kV autotransformer, the 345 kV transmission line, and the two 230 kV transmission lines would also be identified as Elements meeting this criterion. The 50 MW combustion turbines and 66 kV transmission lines would not be identified pursuant to Criterion 1 because these Elements are not subject to an operating limit or RAS and do not terminate at the Transmission station associated with the generators that are subject to the SOL or RAS.

### Criterion 2

The second criterion involves Elements that are monitored as a part of an established System Operating Limit (SOL) based on an angular stability limit regardless of the outage conditions that result in the enforcement of the SOL. For example, if two long parallel 500 kV transmission lines have a combined SOL of 1,200 MW, and this limit is based on angular instability resulting from a fault and subsequent loss of one of the two lines, then both lines would be identified as Elements meeting the criterion.

### Criterion 3

The third criterion involves Elements that form the boundary of an island within an underfrequency load shedding (UFLS) design assessment. The criterion applies to islands identified based on application of the Planning Coordinator's criteria for identifying islands, where the island is formed by tripping the Elements based on angular instability. The criterion applies if the angular instability is modeled in the UFLS design assessment, or if the boundary is identified "off-line" (i.e., the Elements are selected based on angular instability considerations, but the Elements are tripped in the UFLS design assessment without modeling the initiating angular instability). In cases where an out-of-step condition is detected and tripping is initiated at an alternate location, the criterion applies to the Element on which the power swing is detected. The criterion does not apply to islands identified based on other considerations that do not involve angular instability, such as excessive loading, Planning Coordinator area boundary tie lines, or Balancing Authority boundary tie lines.

### Criterion 4

The fourth criterion involves Elements identified in the most recent annual Planning Assessment where relay tripping occurs due to a stable or unstable<sup>13</sup> power swing during a simulated disturbance. The intent is for the Planning Coordinator to include any Element(s) where relay tripping was observed during simulations performed for the most recent annual Planning Assessment associated with the transmission planning TPL-001-4 Reliability Standard. Note that relay tripping must be assessed within those annual Planning Assessments per TPL-001-4, R4,

---

<sup>13</sup> Refer to the "Justification for Including Unstable Power Swings in the Requirements" section.

Part 4.3.1.3, which indicates that analysis shall include the “Tripping of Transmission lines and transformers where transient swings cause Protection System operation based on generic or actual relay models.” Identifying such Elements according to Criterion 4 and notifying the respective Generator Owner and Transmission Owner will require that the owners of any load-responsive protective relay applied at the terminals of the identified Element evaluate the relay’s susceptibility to tripping in response to a stable power swing.

Planning Coordinators have the discretion to determine whether the observed tripping for a power swing in its Planning Assessments occurs for valid contingencies and system conditions. The Planning Coordinator will address tripping that is observed in transient analyses on an individual basis; therefore, the Planning Coordinator is responsible for identifying the Elements based only on simulation results that are determined to be valid.

Due to the nature of how a Planning Assessment is performed, there may be cases where a previously-identified Element is not identified in the most recent annual Planning Assessment. If so, this is acceptable because the Generator Owner and Transmission Owner would have taken action upon the initial notification of the previously identified Element. When an Element is not identified in later Planning Assessments, the risk of load-responsive protective relays tripping in response to a stable power swing during non-Fault conditions would have already been assessed under Requirement R2 and mitigated according to Requirements R3 and R4 where the relays did not meet the PRC-026-1 – Attachment B criteria. According to Requirement R2, the Generator Owner and Transmission Owner are only required to re-evaluate each load-responsive protective relay for an identified Element where the evaluation has not been performed in the last five calendar years.

Although Requirement R1 requires the Planning Coordinator to notify the respective Generator Owner and Transmission Owner of any Elements meeting one or more of the four criteria, it does not preclude the Planning Coordinator from providing additional information, such as apparent impedance characteristics, in advance or upon request, that may be useful in evaluating protective relays. Generator Owners and Transmission Owners are able to complete protective relay evaluations and perform the required actions without additional information. The standard does not include any requirement for the entities to provide information that is already being shared or exchanged between entities for operating needs. While a Requirement has not been included for the exchange of information, entities should recognize that relay performance needs to be measured against the most current information.

### **Requirement R2**

Requirement R2 requires the Generator Owner and Transmission Owner to evaluate its load-responsive protective relays to ensure that they are expected to not trip in response to stable power swings.

## **PRC-026-1 – Application Guidelines**

---

The PRC-026-1 – Attachment A lists the applicable load-responsive relays that must be evaluated which include phase distance, phase overcurrent, out-of-step tripping, and loss-of-field relay functions. Phase distance relays could include, but are not limited to, the following:

- Zone elements with instantaneous tripping or intentional time delays of less than 15 cycles
- Phase distance elements used in high-speed communication-aided tripping schemes including:
  - Directional Comparison Blocking (DCB) schemes
  - Directional Comparison Un-Blocking (DCUB) schemes
  - Permissive Overreach Transfer Trip (POTT) schemes
  - Permissive Underreach Transfer Trip (PUTT) schemes

A method is provided within the standard to support consistent evaluation by Generator Owners and Transmission Owners based on specified conditions. Once a Generator Owner or Transmission Owner is notified of Elements pursuant to Requirement R1, it has 12 full calendar months to determine if each Element's load-responsive protective relays meet the PRC-026-1 – Attachment B criteria, if the determination has not been performed in the last five calendar years. Additionally, each Generator Owner and Transmission Owner, that becomes aware of a generator, transformer, or transmission line BES Element that tripped in response to a stable or unstable power swing due to the operation of its protective relays pursuant to Requirement R2, Part 2.2, must perform the same PRC-026-1 – Attachment B criteria determination within 12 full calendar months.

### **Becoming Aware of an Element That Tripped in Response to a Power Swing**

Part 2.2 in Requirement R2 is intended to initiate action by the Generator Owner and Transmission Owner when there is a known stable or unstable power swing and it resulted in the entity's Element tripping. The criterion starts with becoming aware of the event (i.e., power swing) and then any connection with the entity's Element tripping. By doing so, the focus is removed from the entity having to demonstrate that it made a determination whether a power swing was present for every Element trip. The basis for structuring the criterion in this manner is driven by the available ways that a Generator Owner and Transmission Owner could become aware of an Element that tripped in response to a stable or unstable power swing due to the operation of its protective relay(s).

Element trips caused by stable or unstable power swings, though infrequent, would be more common in a larger event. The identification of power swings will be revealed during an analysis of the event. Event analysis where an entity may become aware of a stable or unstable power swing could include internal analysis conducted by the entity, the entity's Protection System review following a trip, or a larger scale analysis by other entities. Event analysis could include involvement by the entity's Regional Entity, and in some cases NERC.

### **Information Common to Both Generation and Transmission Elements**

The PRC-026-1 – Attachment A lists the load-responsive protective relays that are subject to this standard. Generator Owners and Transmission Owners may own load-responsive protective relays (e.g., distance relays) that directly affect generation or transmission BES Elements and will require analysis as a result of Elements being identified by the Planning Coordinator in Requirement R1

or the Generator Owner or Transmission Owner in Requirement R2. For example, distance relays owned by the Transmission Owner may be installed at the high-voltage side of the generator step-up (GSU) transformer (directional toward the generator) providing backup to generation protection. Generator Owners may have distance relays applied to backup transmission protection or backup protection to the GSU transformer. The Generator Owner may have relays installed at the generator terminals or the high-voltage side of the GSU transformer.

**Exclusion of Time Based Load-Responsive Protective Relays**

The purpose of the standard is “[t]o ensure that load-responsive protective relays are expected to not trip in response to stable power swings during non-Fault conditions.” Load-responsive, high-speed tripping protective relays pose the highest risk of operating during a power swing. Because of this, high-speed tripping protective relays and relays with a time delay of less than 15 cycles are included in the standard; whereas other relays (i.e., Zones 2 and 3) with a time delay of 15 cycles or greater are excluded. The time delay used for exclusion on some load-responsive protective relays is based on the maximum expected time that load-responsive protective relays would be exposed to a stable power swing with a slow slip rate frequency.

In order to establish a time delay that distinguishes a high-risk load-responsive protective relay from one that has a time delay for tripping (lower-risk), a sample of swing rates were calculated based on a stable power swing entering and leaving the impedance characteristic as shown in Table 1. For a relay impedance characteristic that has a power swing entering and leaving, beginning at 90 degrees with a termination at 120 degrees before exiting the zone, the zone timer must be greater than the calculated time the stable power swing is inside the relay’s operating zone to not trip in response to the stable power swing.

Eq. (1) 
$$Zone\ timer > 2 \times \left( \frac{(120^\circ - Angle\ of\ entry\ into\ the\ relay\ characteristic) \times 60}{(360 \times Slip\ Rate)} \right)$$

<b>Table 1: Swing Rates</b>	
<b>Zone Timer (Cycles)</b>	<b>Slip Rate (Hz)</b>
10	1.00
15	0.67
20	0.50
30	0.33

With a minimum zone timer of 15 cycles, the corresponding slip rate of the system is 0.67 Hz. This represents an approximation of a slow slip rate during a system Disturbance. Longer time delays allow for slower slip rates.

### Application to Transmission Elements

Criterion A in PRC-026-1 – Attachment B describes an unstable power swing region that is formed by the union of three shapes in the impedance (R-X) plane. The first shape is a lower loss-of-synchronism circle based on a ratio of the sending-end to receiving-end voltages of 0.7 (i.e.,  $E_S / E_R = 0.7 / 1.0 = 0.7$ ). The second shape is an upper loss-of-synchronism circle based on a ratio of the sending-end to receiving-end voltages of 1.43 (i.e.,  $E_S / E_R = 1.0 / 0.7 = 1.43$ ). The third shape is a lens that connects the endpoints of the total system impedance together by varying the sending-end and receiving-end system voltages from 0.0 to 1.0 per unit, while maintaining a constant system separation angle across the total system impedance (with the parallel transfer impedance removed—see Figures 1 through 5). The total system impedance is derived from a two-bus equivalent network and is determined by summing the sending-end source impedance, the line impedance (excluding the Thévenin equivalent transfer impedance), and the receiving-end source impedance as shown in Figures 6 and 7. Establishing the total system impedance provides a conservative condition that will maximize the security of the relay against various system conditions. The smallest total system impedance represents a condition where the size of the lens characteristic in the R-X plane is smallest and is a conservative operating point from the standpoint of ensuring a load-responsive protective relay is expected to not trip given a predetermined angular displacement between the sending-end and receiving-end voltages. The smallest total system impedance results when all generation is in service and all transmission BES Elements are modeled in their “normal” system configuration (PRC-026-1 – Attachment B, Criterion A). The parallel transfer impedance is removed to represent a likely condition where parallel Elements may be lost during the disturbance, and the loss of these Elements magnifies the sensitivity of the load-responsive relays on the parallel line by removing the “infeed effect” (i.e., the apparent impedance sensed by the relay is decreased as a result of the loss of the transfer impedance, thus making the relay more likely to trip for a stable power swing—See Figures 13 and 14).

The sending-end and receiving-end source voltages are varied from 0.7 to 1.0 per unit to form the lower and upper loss-of-synchronism circles. The ratio of these two voltages is used in the calculation of the loss-of-synchronism circles, and result in a ratio range from 0.7 to 1.43.

$$\text{Eq. (2)} \quad \frac{E_S}{E_R} = \frac{0.7}{1.0} = 0.7$$

$$\text{Eq. (3):} \quad \frac{E_S}{E_R} = \frac{1.0}{0.7} = 1.43$$

The internal generator voltage during severe power swings or transmission system fault conditions will be greater than zero due to voltage regulator support. The voltage ratio of 0.7 to 1.43 is chosen to be more conservative than the PRC-023<sup>14</sup> and PRC-025<sup>15</sup> NERC Reliability Standards where a lower bound voltage of 0.85 per unit voltage is used. A  $\pm 15\%$  internal generator voltage range was chosen as a conservative voltage range for calculation of the voltage ratio used to calculate the loss-of-synchronism circles. For example, the voltage ratio using these voltages would result in a ratio range from 0.739 to 1.353.

---

<sup>14</sup> Transmission Relay Loadability

<sup>15</sup> Generator Relay Loadability

Eq. (4) 
$$\frac{E_S}{E_R} = \frac{0.85}{1.15} = 0.739$$

Eq. (5): 
$$\frac{E_S}{E_R} = \frac{1.15}{0.85} = 1.353$$

The lower ratio is rounded down to 0.7 to be more conservative, allowing a voltage range of 0.7 to 1.0 per unit to be used for the calculation of the loss-of-synchronism circles.<sup>16</sup>

When the parallel transfer impedance is included in the model, the division of current through the parallel transfer impedance path results in actual measured relay impedances that are larger than those measured when the parallel transfer impedance is removed (i.e., infeed effect), which would make it more likely for an impedance relay element to be completely contained within the unstable power swing region as shown in Figure 11. If the transfer impedance is included in the evaluation, a distance relay element could be deemed as meeting PRC-026-1 – Attachment B criteria and, in fact would be secure, assuming all Elements were in their normal state. In this case, the distance relay element could trip in response to a stable power swing during an actual event if the system was weakened (i.e., a higher transfer impedance) by the loss of a subset of lines that make up the parallel transfer impedance as shown in Figure 10. This could happen because the subset of lines that make up the parallel transfer impedance tripped on unstable swings, contained the initiating fault, and/or were lost due to operation of breaker failure or remote back-up protection schemes.

Table 10 shows the percent size increase of the lens shape as seen by the relay under evaluation when the parallel transfer impedance is included. The parallel transfer impedance has minimal effect on the apparent size of the lens shape as long as the parallel transfer impedance is at least 10 multiples of the parallel line impedance (less than 5% lens shape expansion), therefore, its removal has minimal impact, but results in a slightly more conservative, smaller lens shape. Parallel transfer impedances of 5 multiples of the parallel line impedance or less result in an apparent lens shape size of 10% or greater as seen by the relay. If two parallel lines and a parallel transfer impedance tie the sending-end and receiving-end buses together, the total parallel transfer impedance will be one or less multiples of the parallel line impedance, resulting in an apparent lens shape size of 45% or greater. It is a realistic contingency that the parallel line could be out-of-service, leaving the parallel transfer impedance making up the rest of the system in parallel with the line impedance. Since it is not known exactly which lines making up the parallel transfer impedance will be out of service during a major system disturbance, it is most conservative to assume that all of them are out, leaving just the line under evaluation in service.

Either the saturated transient or sub-transient direct axis reactance may be used for machines in the evaluation because they are smaller than the un-saturated reactances. Since saturated sub-transient generator reactances are smaller than the transient or synchronous reactances, the use of sub-transient reactances will result in a smaller source impedance and a smaller unstable power swing region in the graphical analysis as shown in Figures 8 and 9. Because power swings occur in a time frame where generator transient reactances will be prevalent, it is acceptable to use saturated transient reactances instead of saturated sub-transient reactances. Because some short-

---

<sup>16</sup> *Final Report on the August 14, 2003 Blackout in the United States and Canada: Causes and Recommendations*, April 2004, Section 6 (The Cascade Stage of the Blackout), p. 94 under “Why the Generators Tripped Off,” states, “Some generator undervoltage relays were set to trip at or above 90% voltage. However, a motor stalls out at about 70% voltage and a motor starter contactor drops out around 75%, so if there is a compelling need to protect the turbine from the system the under-voltage trigger point should be no higher than 80%.”



circuit models may not include transient reactances, the use of sub-transient reactances is also acceptable because it produces more conservative results. For this reason, either value is acceptable when determining the system source impedances (PRC-026-1 – Attachment B, Criterion A and B, No. 3).

Saturated reactances are used in short-circuit programs that produce the system impedance mentioned above. Planning and stability software generally use un-saturated reactances. Generator models used in transient stability analyses recognize that the extent of the saturation effect depends upon both rotor (field) and stator currents. Accordingly, they derive the effective saturated parameters of the machine at each instant by internal calculation from the specified (constant) unsaturated values of machine reactances and the instantaneous internal flux level. The specific assumptions regarding which inductances are affected by saturation, and the relative effect of that saturation, are different for the various generator models used. Thus, unsaturated values of all machine reactances are used in setting up planning and stability software data, and the appropriate set of open-circuit magnetization curve data is provided for each machine.

Saturated reactance values are smaller than unsaturated reactance values and are used in short-circuit programs owned by the Generator and Transmission Owners. Because of this, saturated reactance values are to be used in the development of the system source impedances.

The source or system equivalent impedances can be obtained by a number of different methods using commercially available short-circuit calculation tools.<sup>17</sup> Most short-circuit tools have a network reduction feature that allows the user to select the local and remote terminal buses to retain. The first method reduces the system to one that contains two buses, an equivalent generator at each bus (representing the source impedances at the sending-end and receiving-end), and two parallel lines; one being the line impedance of the protected line with relays being analyzed, the other being the parallel transfer impedance representing all other combinations of lines that connect the two buses together as shown in Figure 6. Another conservative method is to open both ends of the line being evaluated, and apply a three-phase bolted fault at each bus to determine the Thévenin equivalent impedance at each bus. The source impedances are set equal to the Thévenin equivalent impedances and will be less than or equal to the actual source impedances calculated by the network reduction method. Either method can be used to develop the system source impedances at both ends.

The two bullets of PRC-026-1 – Attachment B, Criterion A, No. 1, identify the system separation angles used to identify the size of the power swing stability boundary for evaluating load-responsive protective relay impedance elements. The first bullet of PRC-026-1 – Attachment B, Criterion A, No. 1 evaluates a system separation angle of at least 120 degrees that is held constant while varying the sending-end and receiving-end source voltages from 0.7 to 1.0 per unit, thus creating an unstable power swing region about the total system impedance in Figure 1. This unstable power swing region is compared to the tripping portion of the distance relay characteristic; that is, the portion that is not supervised by load encroachment, blinders, or some other form of supervision as shown in Figure 12 that restricts the distance element from tripping

---

<sup>17</sup> Demetrios A. Tziouvaras and Daqing Hou, Appendix in *Out-Of-Step Protection Fundamentals and Advancements*, April 17, 2014: <https://www.selinc.com>.

## PRC-026-1 – Application Guidelines

---

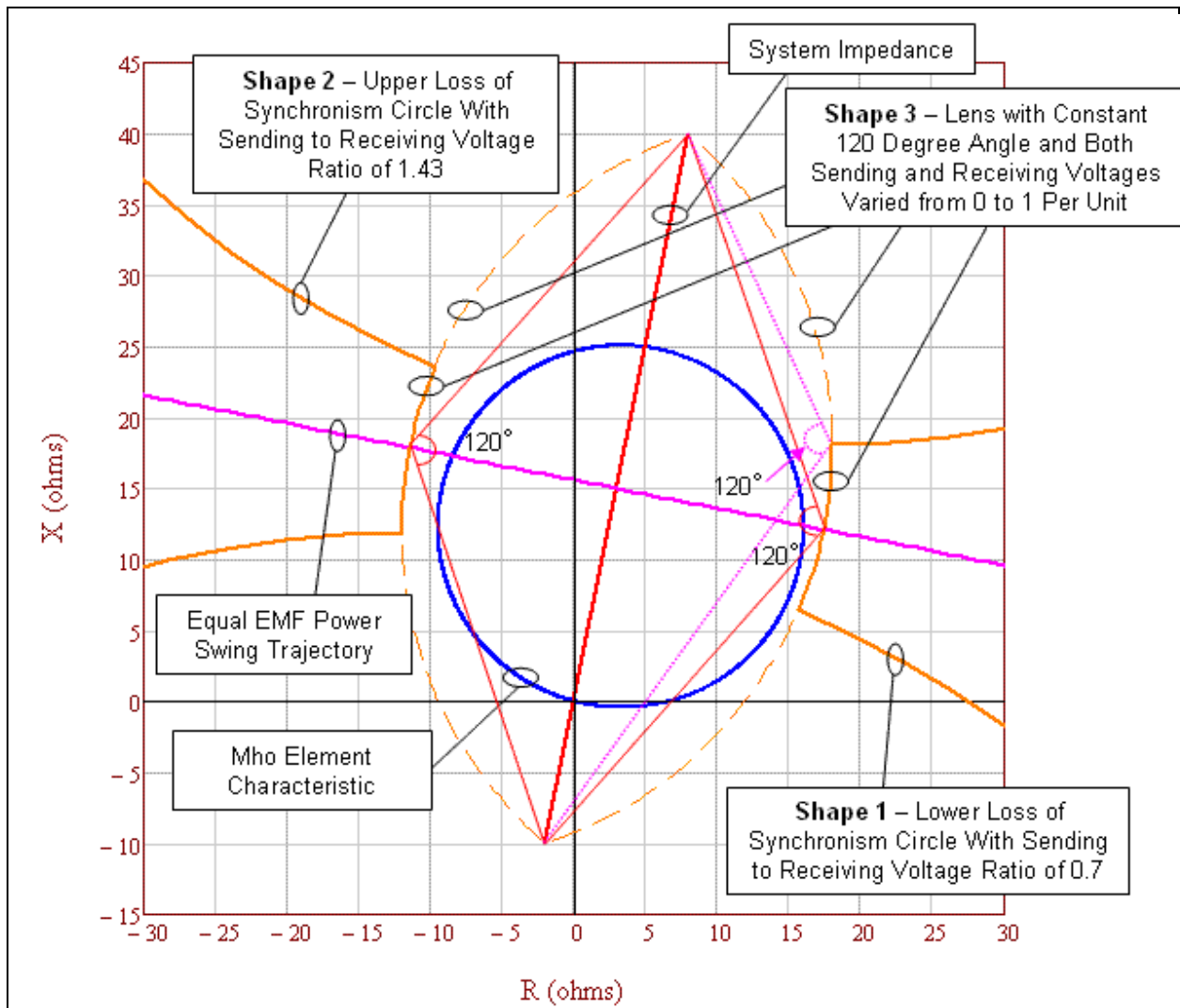
for heavy, balanced load conditions. If the tripping portion of the impedance characteristics are completely contained within the unstable power swing region, the relay impedance element meets Criterion A in PRC-026-1 – Attachment B. A system separation angle of 120 degrees was chosen for the evaluation because it is generally accepted in the industry that recovery for a swing beyond this angle is unlikely to occur.<sup>18</sup>

The second bullet of PRC-026-1 – Attachment B, Criterion A, No. 1 evaluates impedance relay elements at a system separation angle of less than 120 degrees, similar to the first bullet described above. An angle less than 120 degrees may be used if a documented stability analysis demonstrates that the power swing becomes unstable at a system separation angle of less than 120 degrees.

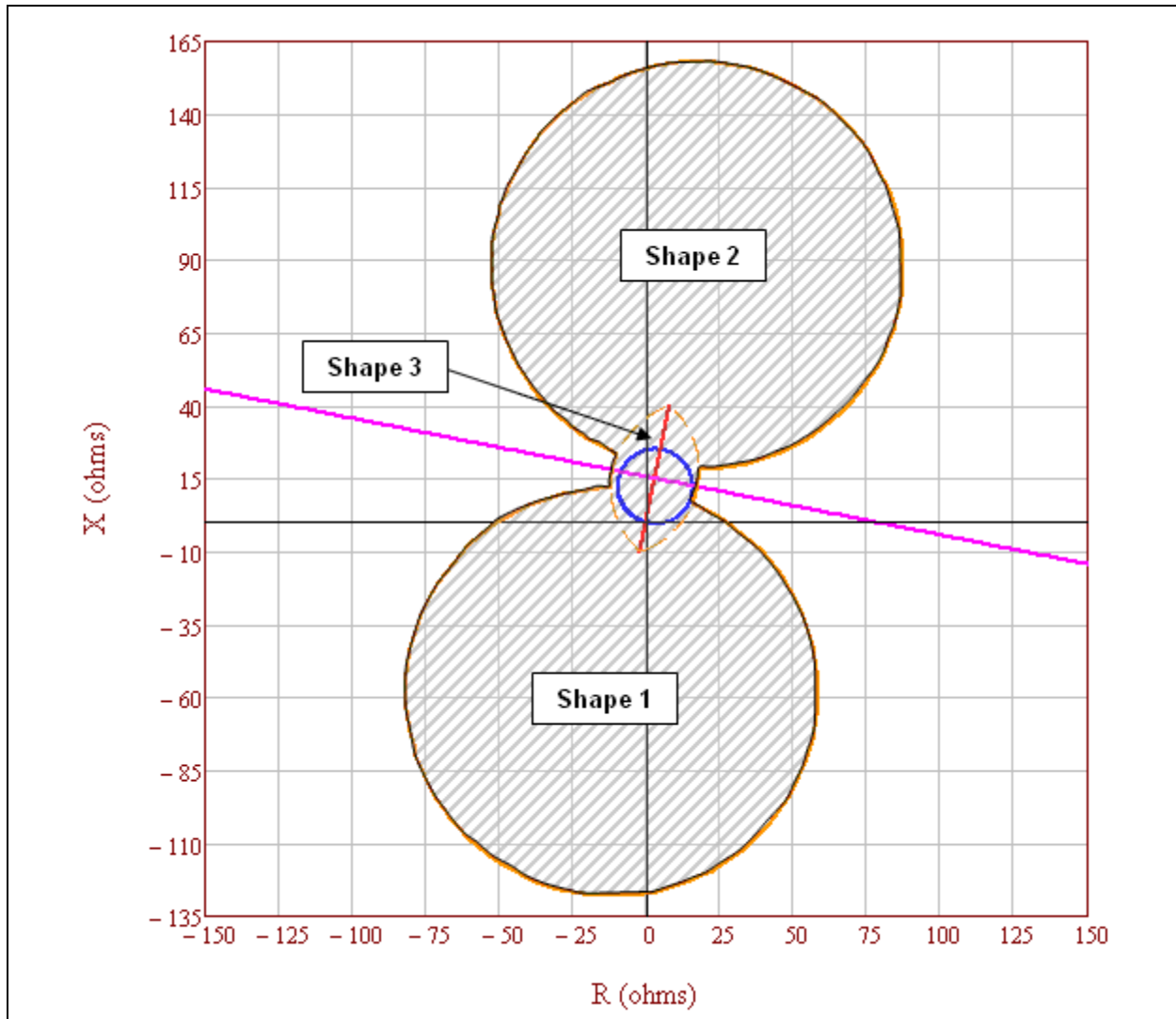
The exclusion of relay elements supervised by Power Swing Blocking (PSB) in PRC-026-1 – Attachment A allows the Generator Owner or Transmission Owner to exclude protective relay elements if they are blocked from tripping by PSB relays. A PSB relay applied and set according to industry accepted practices prevent supervised load-responsive protective relays from tripping in response to power swings. Further, PSB relays are set to allow dependable tripping of supervised elements. The criteria in PRC-026-1 – Attachment B specifically applies to unsupervised elements that could trip for stable power swings. Therefore, load-responsive protective relay elements supervised by PSB can be excluded from the Requirements of this standard.

---

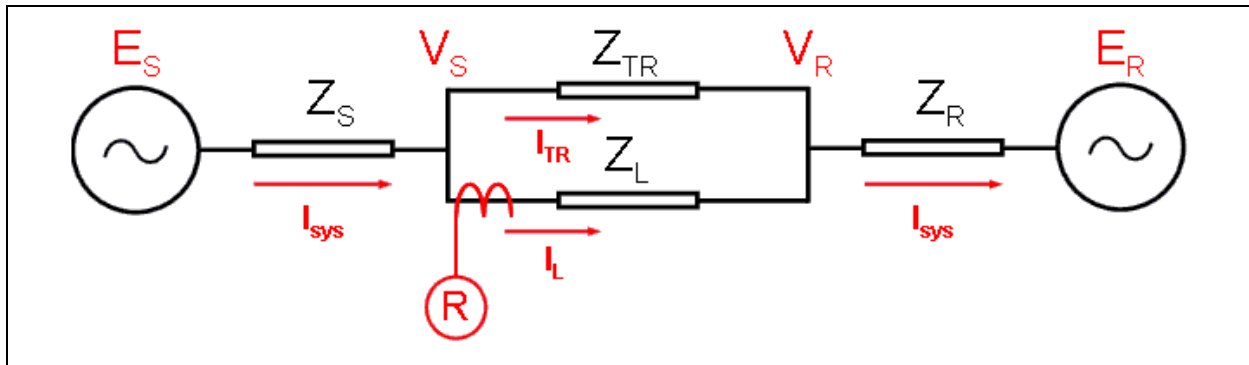
<sup>18</sup> “The critical angle for maintaining stability will vary depending on the contingency and the system condition at the time the contingency occurs; however, the likelihood of recovering from a swing that exceeds 120 degrees is marginal and 120 degrees is generally accepted as an appropriate basis for setting out-of-step protection. Given the importance of separating unstable systems, defining 120 degrees as the critical angle is appropriate to achieve a proper balance between dependable tripping for unstable power swings and secure operation for stable power swings.” NERC System Protection and Control Subcommittee, *Protection System Response to Power Swings*, August 2013: [http://www.nerc.com/comm/PC/System%20Protection%20and%20Control%20Subcommittee%20SPCS%2020/SPCS%20Power%20Swing%20Report\\_Final\\_20131015.pdf](http://www.nerc.com/comm/PC/System%20Protection%20and%20Control%20Subcommittee%20SPCS%2020/SPCS%20Power%20Swing%20Report_Final_20131015.pdf), p. 28.



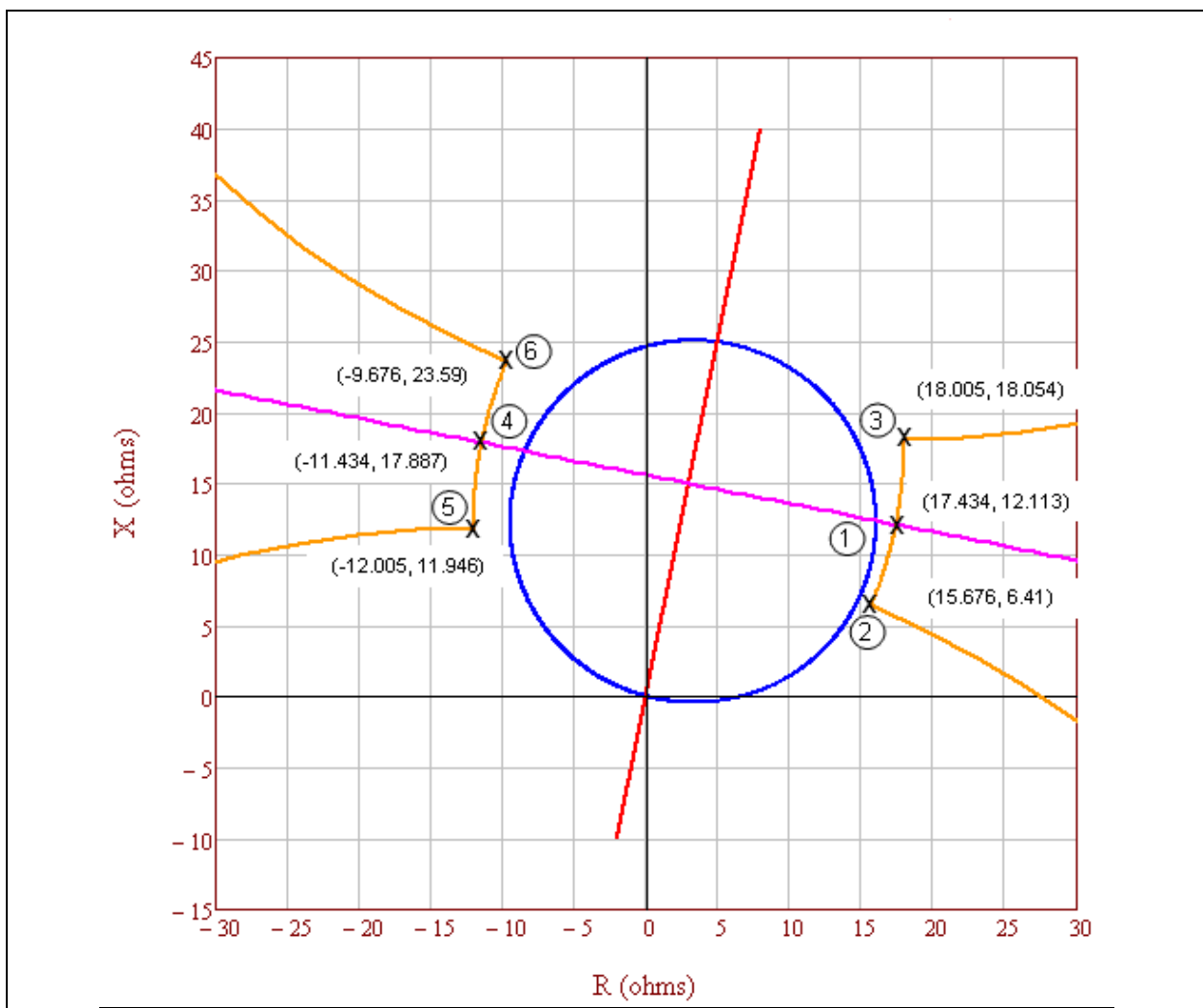
**Figure 1:** An enlarged graphic illustrating the unstable power swing region formed by the union of three shapes in the impedance (R-X) plane: Shape 1) Lower loss-of-synchronism circle, Shape 2) Upper loss-of-synchronism circle, and Shape 3) Lens. The mho element characteristic is completely contained within the unstable power swing region (i.e., it does not intersect any portion of the unstable power swing region), therefore it meets PRC-026-1 – Attachment B, Criterion A, No. 1.



**Figure 2:** Full graphic of the unstable power swing region formed by the union of the three shapes in the impedance (R-X) plane: Shape 1) Lower loss-of-synchronism circle, Shape 2) Upper loss-of-synchronism circle, and Shape 3) Lens. The mho element characteristic is completely contained within the unstable power swing region, therefore it meets PRC-26-1 – Attachment B, Criterion A, No.1.



**Figure 3:** System impedances as seen by Relay R (voltage connections are not shown).



**Figure 4:** The defining unstable power swing region points where the lens shape intersects the lower and upper loss-of-synchronism circle shapes and where the lens intersects the equal EMF (electromotive force) power swing.

E <sub>S</sub> / E <sub>R</sub> Voltage Ratio	Left Side Coordinates		Right Side Coordinates	
	R	+ jX	R	+ jX
<b>0.7</b>	<b>-12.005</b>	<b>11.946</b>	<b>15.676</b>	<b>6.41</b>
0.72	-12.004	12.407	15.852	6.836
0.74	-11.996	12.857	16.018	7.255
0.76	-11.982	13.298	16.175	7.667
0.78	-11.961	13.729	16.321	8.073
0.8	-11.935	14.151	16.459	8.472
0.82	-11.903	14.563	16.589	8.865
0.84	-11.867	14.966	16.71	9.251
0.86	-11.826	15.361	16.824	9.631
0.88	-11.78	15.746	16.93	10.004
0.9	-11.731	16.123	17.03	10.371
0.92	-11.678	16.492	17.123	10.732
0.94	-11.621	16.852	17.209	11.086
0.96	-11.562	17.205	17.29	11.435
0.98	-11.499	17.55	17.364	11.777
<b>1</b>	<b>-11.434</b>	<b>17.887</b>	<b>17.434</b>	<b>12.113</b>
1.0286	-11.336	18.356	17.524	12.584
1.0572	-11.234	18.81	17.604	13.043
1.0858	-11.127	19.251	17.675	13.49
1.1144	-11.017	19.677	17.738	13.926
1.143	-10.904	20.091	17.792	14.351
1.1716	-10.788	20.491	17.84	14.766
1.2002	-10.67	20.88	17.88	15.17
1.2288	-10.55	21.256	17.914	15.564
1.2574	-10.428	21.621	17.942	15.948
1.286	-10.304	21.975	17.964	16.322
1.3146	-10.18	22.319	17.981	16.687
1.3432	-10.054	22.652	17.993	17.043
1.3718	-9.928	22.976	18.001	17.39
1.4004	-9.801	23.29	18.005	17.728
<b>1.429</b>	<b>-9.676</b>	<b>23.59</b>	<b>18.005</b>	<b>18.054</b>

**Figure 5:** Full table of 31 detailed lens shape point calculations. The bold highlighted rows correspond to the detailed calculations in Tables 2-7.

Table 2: Example Calculation (Lens Point 1)	
This example is for calculating the impedance the first point of the lens characteristic. Equal source voltages are used for the 230 kV (base) line with the sending-end voltage (E <sub>S</sub> ) leading the receiving-end voltage (E <sub>R</sub> ) by 120 degrees. See Figures 3 and 4.	
Eq. (6)	$E_S = \frac{V_{LL} \angle 120^\circ}{\sqrt{3}}$

Table 2: Example Calculation (Lens Point 1)			
	$E_S = \frac{230,000 \angle 120^\circ V}{\sqrt{3}}$		
	$E_S = 132,791 \angle 120^\circ V$		
Eq. (7)	$E_R = \frac{V_{LL} \angle 0^\circ}{\sqrt{3}}$		
	$E_R = \frac{230,000 \angle 0^\circ V}{\sqrt{3}}$		
	$E_R = 132,791 \angle 0^\circ V$		
Positive sequence impedance data (with transfer impedance $Z_{TR}$ set to a large value).			
Given:	$Z_S = 2 + j10 \Omega$	$Z_L = 4 + j20 \Omega$	$Z_R = 4 + j20 \Omega$
Given:	$Z_{TR} = Z_L \times 10^{10} \Omega$		
Total impedance between the generators.			
Eq. (8)	$Z_{total} = \frac{(Z_L \times Z_{TR})}{(Z_L + Z_{TR})}$		
	$Z_{total} = \frac{((4 + j20) \Omega \times (4 + j20) \times 10^{10} \Omega)}{((4 + j20) \Omega + (4 + j20) \times 10^{10} \Omega)}$		
	$Z_{total} = 4 + j20 \Omega$		
Total system impedance.			
Eq. (9)	$Z_{sys} = Z_S + Z_{total} + Z_R$		
	$Z_{sys} = (2 + j10) \Omega + (4 + j20) \Omega + (4 + j20) \Omega$		
	$Z_{sys} = 10 + j50 \Omega$		
Total system current from sending-end source.			
Eq. (10)	$I_{sys} = \frac{E_S - E_R}{Z_{sys}}$		
	$I_{sys} = \frac{132,791 \angle 120^\circ V - 132,791 \angle 0^\circ V}{(10 + j50) \Omega}$		
	$I_{sys} = 4,511 \angle 71.3^\circ A$		
The current, as measured by the relay on $Z_L$ (Figure 3), is only the current flowing through that line as determined by using the current divider equation.			
Eq. (11)	$I_L = I_{sys} \times \frac{Z_{TR}}{Z_L + Z_{TR}}$		

Table 2: Example Calculation (Lens Point 1)	
	$I_L = 4,511\angle 71.3^\circ A \times \frac{(4 + j20) \times 10^{10} \Omega}{(4 + j20) \Omega + (4 + j20) \times 10^{10} \Omega}$
	$I_L = 4,511\angle 71.3^\circ A$
The voltage, as measured by the relay on $Z_L$ (Figure 3), is the voltage drop from the sending-end source through the sending-end source impedance.	
Eq. (12)	$V_S = E_S - (Z_S \times I_{sys})$
	$V_S = 132,791\angle 120^\circ V - [(2 + j10) \Omega \times 4,511\angle 71.3^\circ A]$
	$V_S = 95,757\angle 106.1^\circ V$
The impedance seen by the relay on $Z_L$ .	
Eq. (13)	$Z_{L-Relay} = \frac{V_S}{I_L}$
	$Z_{L-Relay} = \frac{95,757\angle 106.1^\circ V}{4,511\angle 71.3^\circ A}$
	$Z_{L-Relay} = 17.434 + j12.113 \Omega$

Table 3: Example Calculation (Lens Point 2)	
This example is for calculating the impedance second point of the lens characteristic. Unequal source voltages are used for the 230 kV (base) line with the sending-end voltage ( $E_S$ ) at 70% of the receiving-end voltage ( $E_R$ ) and leading the receiving-end voltage by 120 degrees. See Figures 3 and 4.	
Eq. (14)	$E_S = \frac{V_{LL}\angle 120^\circ}{\sqrt{3}} \times 70\%$
	$E_S = \frac{230,000\angle 120^\circ V}{\sqrt{3}} \times 0.70$
	$E_S = 92,953.7\angle 120^\circ V$
Eq. (15)	$E_R = \frac{V_{LL}\angle 0^\circ}{\sqrt{3}}$
	$E_R = \frac{230,000\angle 0^\circ V}{\sqrt{3}}$
	$E_R = 132,791\angle 0^\circ V$
Positive sequence impedance data (with transfer impedance $Z_{TR}$ set to a large value).	
Given:	$Z_S = 2 + j10 \Omega$ $Z_L = 4 + j20 \Omega$ $Z_R = 4 + j20 \Omega$
Given:	$Z_{TR} = Z_L \times 10^{10} \Omega$



Table 3: Example Calculation (Lens Point 2)	
Total impedance between the generators.	
Eq. (16)	$Z_{total} = \frac{(Z_L \times Z_{TR})}{(Z_L + Z_{TR})}$
	$Z_{total} = \frac{((4 + j20) \Omega \times (4 + j20) \times 10^{10} \Omega)}{((4 + j20) \Omega + (4 + j20) \times 10^{10} \Omega)}$
	$Z_{total} = 4 + j20 \Omega$
Total system impedance.	
Eq. (17)	$Z_{sys} = Z_S + Z_{total} + Z_R$
	$Z_{sys} = (2 + j10) \Omega + (4 + j20) \Omega + (4 + j20) \Omega$
	$Z_{sys} = 10 + j50 \Omega$
Total system current from sending-end source.	
Eq. (18)	$I_{sys} = \frac{E_S - E_R}{Z_{sys}}$
	$I_{sys} = \frac{92,953.7 \angle 120^\circ V - 132,791 \angle 0^\circ V}{(10 + j50) \Omega}$
	$I_{sys} = 3,854 \angle 77^\circ A$
The current, as measured by the relay on $Z_L$ (Figure 3), is only the current flowing through that line as determined by using the current divider equation.	
Eq. (19)	$I_L = I_{sys} \times \frac{Z_{TR}}{Z_L + Z_{TR}}$
	$I_L = 3,854 \angle 77^\circ A \times \frac{(4 + j20) \times 10^{10} \Omega}{(4 + j20) \Omega + (4 + j20) \times 10^{10} \Omega}$
	$I_L = 3,854 \angle 77^\circ A$
The voltage, as measured by the relay on $Z_L$ (Figure 3), is the voltage drop from the sending-end source through the sending-end source impedance.	
Eq. (20)	$V_S = E_S - (Z_S \times I_{sys})$
	$V_S = 92,953 \angle 120^\circ V - [(2 + j10) \Omega \times 3,854 \angle 77^\circ A]$
	$V_S = 65,271 \angle 99^\circ V$
The impedance seen by the relay on $Z_L$ .	
Eq. (21)	$Z_{L-Relay} = \frac{V_S}{I_L}$

Table 3: Example Calculation (Lens Point 2)	
	$Z_{L-Relay} = \frac{65,271 \angle 99^\circ V}{3,854 \angle 77^\circ A}$
	$Z_{L-Relay} = 15.676 + j6.41 \Omega$

Table 4: Example Calculation (Lens Point 3)	
This example is for calculating the impedance third point of the lens characteristic. Unequal source voltages are used for the 230 kV (base) line with the receiving-end voltage ( $E_R$ ) at 70% of the sending-end voltage ( $E_S$ ) and the sending-end voltage leading the receiving-end voltage by 120 degrees. See Figures 3 and 4.	
Eq. (22)	$E_S = \frac{V_{LL} \angle 120^\circ}{\sqrt{3}}$
	$E_S = \frac{230,000 \angle 120^\circ V}{\sqrt{3}}$
	$E_S = 132,791 \angle 120^\circ V$
Eq. (23)	$E_R = \frac{V_{LL} \angle 0^\circ}{\sqrt{3}} \times 70\%$
	$E_R = \frac{230,000 \angle 0^\circ V}{\sqrt{3}} \times 0.70$
	$E_R = 92,953.7 \angle 0^\circ V$
Positive sequence impedance data (with transfer impedance $Z_{TR}$ set to a large value).	
Given:	$Z_S = 2 + j10 \Omega$ $Z_L = 4 + j20 \Omega$ $Z_R = 4 + j20 \Omega$
Given:	$Z_{TR} = Z_L \times 10^{10} \Omega$
Total impedance between the generators.	
Eq. (24)	$Z_{total} = \frac{(Z_L \times Z_{TR})}{(Z_L + Z_{TR})}$
	$Z_{total} = \frac{((4 + j20) \Omega \times (4 + j20) \times 10^{10} \Omega)}{((4 + j20) \Omega + (4 + j20) \times 10^{10} \Omega)}$
	$Z_{total} = 4 + j20 \Omega$
Total system impedance.	
Eq. (25)	$Z_{sys} = Z_S + Z_{total} + Z_R$
	$Z_{sys} = (2 + j10) \Omega + (4 + j20) \Omega + (4 + j20) \Omega$
	$Z_{sys} = 10 + j50 \Omega$

Table 4: Example Calculation (Lens Point 3)	
Total system current from sending-end source.	
Eq. (26)	$I_{sys} = \frac{E_S - E_R}{Z_{sys}}$
	$I_{sys} = \frac{132,791 \angle 120^\circ V - 92,953.7 \angle 0^\circ V}{(10 + j50) \Omega}$
	$I_{sys} = 3,854 \angle 65.5^\circ A$
The current, as measured by the relay on Z <sub>L</sub> (Figure 3), is only the current flowing through that line as determined by using the current divider equation.	
Eq. (27)	$I_L = I_{sys} \times \frac{Z_{TR}}{Z_L + Z_{TR}}$
	$I_L = 3,854 \angle 65.5^\circ A \times \frac{(4 + j20) \times 10^{10} \Omega}{(4 + j20) \Omega + (4 + j20) \times 10^{10} \Omega}$
	$I_L = 3,854 \angle 65.5^\circ A$
The voltage, as measured by the relay on Z <sub>L</sub> (Figure 3), is the voltage drop from the sending-end source through the sending-end source impedance.	
Eq. (28)	$V_S = E_S - (Z_S \times I_L)$
	$V_S = 132,791 \angle 120^\circ V - [(2 + j10) \Omega \times 3,854 \angle 65.5^\circ A]$
	$V_S = 98,265 \angle 110.6^\circ V$
The impedance seen by the relay on Z <sub>L</sub> .	
Eq. (29)	$Z_{L-Relay} = \frac{V_S}{I_L}$
	$Z_{L-Relay} = \frac{98,265 \angle 110.6^\circ V}{3,854 \angle 65.5^\circ A}$
	$Z_{L-Relay} = 18.005 + j18.054 \Omega$

Table 5: Example Calculation (Lens Point 4)	
This example is for calculating the impedance fourth point of the lens characteristic. Equal source voltages are used for the 230 kV (base) line with the sending-end voltage (E <sub>S</sub> ) leading the receiving-end voltage (E <sub>R</sub> ) by 240 degrees. See Figures 3 and 4.	
Eq. (30)	$E_S = \frac{V_{LL} \angle 240^\circ}{\sqrt{3}}$
	$E_S = \frac{230,000 \angle 240^\circ V}{\sqrt{3}}$

Table 5: Example Calculation (Lens Point 4)			
	$E_S = 132,791 \angle 240^\circ V$		
Eq. (31)	$E_R = \frac{V_{LL} \angle 0^\circ}{\sqrt{3}}$		
	$E_R = \frac{230,000 \angle 0^\circ V}{\sqrt{3}}$		
	$E_R = 132,791 \angle 0^\circ V$		
Positive sequence impedance data (with transfer impedance $Z_{TR}$ set to a large value).			
Given:	$Z_S = 2 + j10 \Omega$	$Z_L = 4 + j20 \Omega$	$Z_R = 4 + j20 \Omega$
Given:	$Z_{TR} = Z_L \times 10^{10} \Omega$		
Total impedance between the generators.			
Eq. (32)	$Z_{total} = \frac{(Z_L \times Z_{TR})}{(Z_L + Z_{TR})}$		
	$Z_{total} = \frac{((4 + j20) \Omega \times (4 + j20) \times 10^{10} \Omega)}{((4 + j20) \Omega + (4 + j20) \times 10^{10} \Omega)}$		
	$Z_{total} = 4 + j20 \Omega$		
Total system impedance.			
Eq. (33)	$Z_{sys} = Z_S + Z_{total} + Z_R$		
	$Z_{sys} = (2 + j10) \Omega + (4 + j20) \Omega + (4 + j20) \Omega$		
	$Z_{sys} = 10 + j50 \Omega$		
Total system current from sending-end source.			
Eq. (34)	$I_{sys} = \frac{E_S - E_R}{Z_{sys}}$		
	$I_{sys} = \frac{132,791 \angle 240^\circ V - 132,791 \angle 0^\circ V}{(10 + j50) \Omega}$		
	$I_{sys} = 4,511 \angle 131.3^\circ A$		
The current, as measured by the relay on $Z_L$ (Figure 3), is only the current flowing through that line as determined by using the current divider equation.			
Eq. (35)	$I_L = I_{sys} \times \frac{Z_{TR}}{Z_L + Z_{TR}}$		
	$I_L = 4,511 \angle 131.1^\circ A \times \frac{(4 + j20) \times 10^{10} \Omega}{(4 + j20) \Omega + (4 + j20) \times 10^{10} \Omega}$		
	$I_L = 4,511 \angle 131.1^\circ A$		

Table 5: Example Calculation (Lens Point 4)	
The voltage, as measured by the relay on $Z_L$ (Figure 3), is the voltage drop from the sending-end source through the sending-end source impedance.	
Eq. (36)	$V_S = E_S - (Z_S \times I_L)$
	$V_S = 132,791 \angle 240^\circ V - [(2 + j10) \Omega \times 4,511 \angle 131.1^\circ A]$
	$V_S = 95,756 \angle -106.1^\circ V$
The impedance seen by the relay on $Z_L$ .	
Eq. (37)	$Z_{L-Relay} = \frac{V_S}{I_L}$
	$Z_{L-Relay} = \frac{95,756 \angle -106.1^\circ V}{4,511 \angle 131.1^\circ A}$
	$Z_{L-Relay} = -11.434 + j17.887 \Omega$

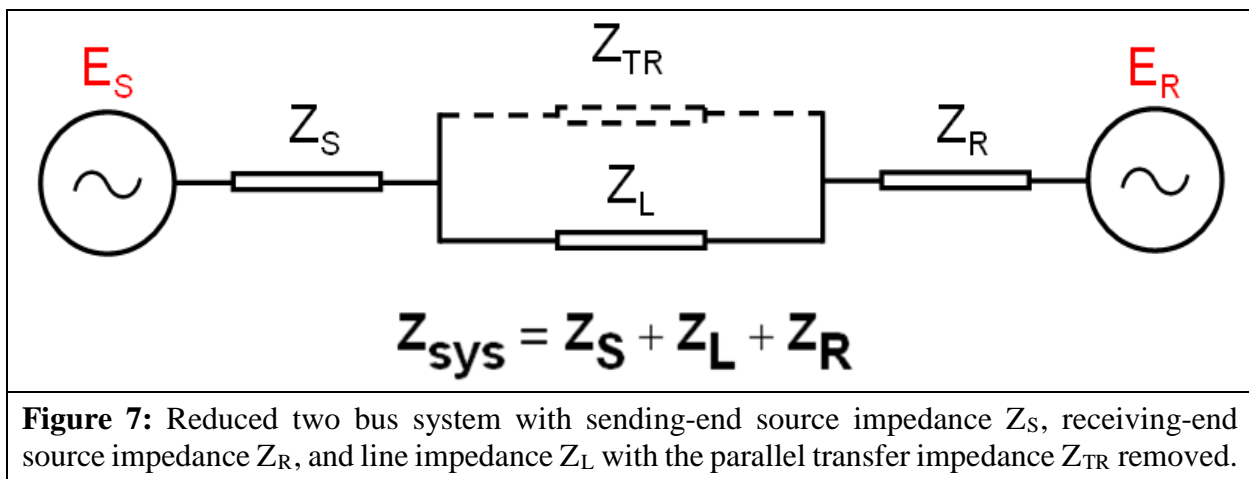
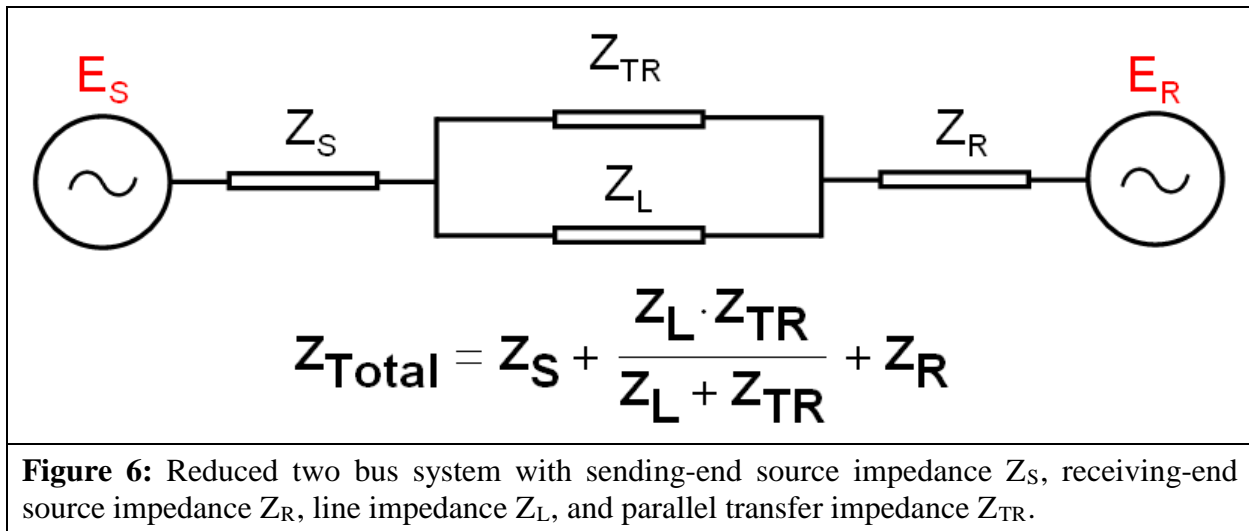
Table 6: Example Calculation (Lens Point 5)	
This example is for calculating the impedance fifth point of the lens characteristic. Unequal source voltages are used for the 230 kV (base) line with the sending-end voltage ( $E_S$ ) at 70% of the receiving-end voltage ( $E_R$ ) and leading the receiving-end voltage by 240 degrees. See Figures 3 and 4.	
Eq. (38)	$E_S = \frac{V_{LL} \angle 240^\circ}{\sqrt{3}} \times 70\%$
	$E_S = \frac{230,000 \angle 240^\circ V}{\sqrt{3}} \times 0.70$
	$E_S = 92,953.7 \angle 240^\circ V$
Eq. (39)	$E_R = \frac{V_{LL} \angle 0^\circ}{\sqrt{3}}$
	$E_R = \frac{230,000 \angle 0^\circ V}{\sqrt{3}}$
	$E_R = 132,791 \angle 0^\circ V$
Positive sequence impedance data (with transfer impedance $Z_{TR}$ set to a large value).	
Given:	$Z_S = 2 + j10 \Omega$ $Z_L = 4 + j20 \Omega$ $Z_R = 4 + j20 \Omega$
Given:	$Z_{TR} = Z_L \times 10^{10} \Omega$
Total impedance between the generators.	
Eq. (40)	$Z_{total} = \frac{(Z_L \times Z_{TR})}{(Z_L + Z_{TR})}$

Table 6: Example Calculation (Lens Point 5)	
	$Z_{total} = \frac{((4 + j20) \Omega \times (4 + j20) \times 10^{10} \Omega)}{((4 + j20) \Omega + (4 + j20) \times 10^{10} \Omega)}$
	$Z_{total} = 4 + j20 \Omega$
Total system impedance.	
Eq. (41)	$Z_{sys} = Z_S + Z_{total} + Z_R$
	$Z_{sys} = (2 + j10 \Omega) + (4 + j20 \Omega) + (4 + j20 \Omega)$
	$Z_{sys} = 10 + j50 \Omega$
Total system current from sending-end source.	
Eq. (42)	$I_{sys} = \frac{E_S - E_R}{Z_{sys}}$
	$I_{sys} = \frac{92,953.7 \angle 240^\circ V - 132,791 \angle 0^\circ V}{10 + j50 \Omega}$
	$I_{sys} = 3,854 \angle 125.5^\circ A$
The current, as measured by the relay on $Z_L$ (Figure 3), is only the current flowing through that line as determined by using the current divider equation.	
Eq. (43)	$I_L = I_{sys} \times \frac{Z_{TR}}{Z_L + Z_{TR}}$
	$I_L = 3,854 \angle 125.5^\circ A \times \frac{(4 + j20) \times 10^{10} \Omega}{(4 + j20) \Omega + (4 + j20) \times 10^{10} \Omega}$
	$I_L = 3,854 \angle 125.5^\circ A$
The voltage, as measured by the relay on $Z_L$ (Figure 3), is the voltage drop from the sending-end source through the sending-end source impedance.	
Eq. (44)	$V_S = E_S - (Z_S \times I_L)$
	$V_S = 92,953.7 \angle 240^\circ V - [(2 + j10) \Omega \times 3,854 \angle 125.5^\circ A]$
	$V_S = 65,270.5 \angle -99.4^\circ V$
The impedance seen by the relay on $Z_L$ .	
Eq. (45)	$Z_{L-Relay} = \frac{V_S}{I_L}$
	$Z_{L-Relay} = \frac{65,270.5 \angle -99.4^\circ V}{3,854 \angle 125.5^\circ A}$
	$Z_{L-Relay} = -12.005 + j11.946 \Omega$

Table 7: Example Calculation (Lens Point 6)			
This example is for calculating the impedance sixth point of the lens characteristic. Unequal source voltages are used for the 230 kV (base) line with the receiving-end voltage ( $E_R$ ) at 70% of the sending-end voltage ( $E_S$ ) and the sending-end voltage leading the receiving-end voltage by 240 degrees. See Figures 3 and 4.			
Eq. (46)	$E_S = \frac{V_{LL} \angle 240^\circ}{\sqrt{3}}$		
	$E_S = \frac{230,000 \angle 240^\circ V}{\sqrt{3}}$		
	$E_S = 132,791 \angle 240^\circ V$		
Eq. (47)	$E_R = \frac{V_{LL} \angle 0^\circ}{\sqrt{3}} \times 70\%$		
	$E_R = \frac{230,000 \angle 0^\circ V}{\sqrt{3}} \times 0.70$		
	$E_R = 92,953.7 \angle 0^\circ V$		
Positive sequence impedance data (with transfer impedance $Z_{TR}$ set to a large value).			
Given:	$Z_S = 2 + j10 \Omega$	$Z_L = 4 + j20 \Omega$	$Z_R = 4 + j20 \Omega$
Given:	$Z_{TR} = Z_L \times 10^{10} \Omega$		
Total impedance between the generators.			
Eq. (48)	$Z_{total} = \frac{(Z_L \times Z_{TR})}{(Z_L + Z_{TR})}$		
	$Z_{total} = \frac{((4 + j20) \Omega \times (4 + j20) \times 10^{10} \Omega)}{((4 + j20) \Omega + (4 + j20) \times 10^{10} \Omega)}$		
	$Z_{total} = 4 + j20 \Omega$		
Total system impedance.			
Eq. (49)	$Z_{sys} = Z_S + Z_{total} + Z_R$		
	$Z_{sys} = (2 + j10) \Omega + (4 + j20) \Omega + (4 + j20) \Omega$		
	$Z_{sys} = 10 + j50 \Omega$		
Total system current from sending-end source.			
Eq. (50)	$I_{sys} = \frac{E_S - E_R}{Z_{sys}}$		
	$I_{sys} = \frac{132,791 \angle 240^\circ V - 92,953.7 \angle 0^\circ V}{10 + j50 \Omega}$		
	$I_{sys} = 3,854 \angle 137.1^\circ A$		

Table 7: Example Calculation (Lens Point 6)	
The current, as measured by the relay on $Z_L$ (Figure 3), is only the current flowing through that line as determined by using the current divider equation.	
Eq. (51)	$I_L = I_{sys} \times \frac{Z_{TR}}{Z_L + Z_{TR}}$
	$I_L = 3,854 \angle 137.1^\circ A \times \frac{(4 + j20) \times 10^{10} \Omega}{(4 + j20) \Omega + (4 + j20) \times 10^{10} \Omega}$
	$I_L = 3,854 \angle 137.1^\circ A$
The voltage, as measured by the relay on $Z_L$ (Figure 3), is the voltage drop from the sending-end source through the sending-end source impedance.	
Eq. (52)	$V_S = E_S - (Z_S \times I_L)$
	$V_S = 132,791 \angle 240^\circ V - [(2 + j10) \Omega \times 3,854 \angle 137.1^\circ A]$
	$V_S = 98,265 \angle -110.6^\circ V$
The impedance seen by the relay on $Z_L$ .	
Eq. (53)	$Z_{L-Relay} = \frac{V_S}{I_L}$
	$Z_{L-Relay} = \frac{98,265 \angle -110.6^\circ V}{3,854 \angle 137.1^\circ A}$
	$Z_{L-Relay} = -9.676 + j23.59 \Omega$





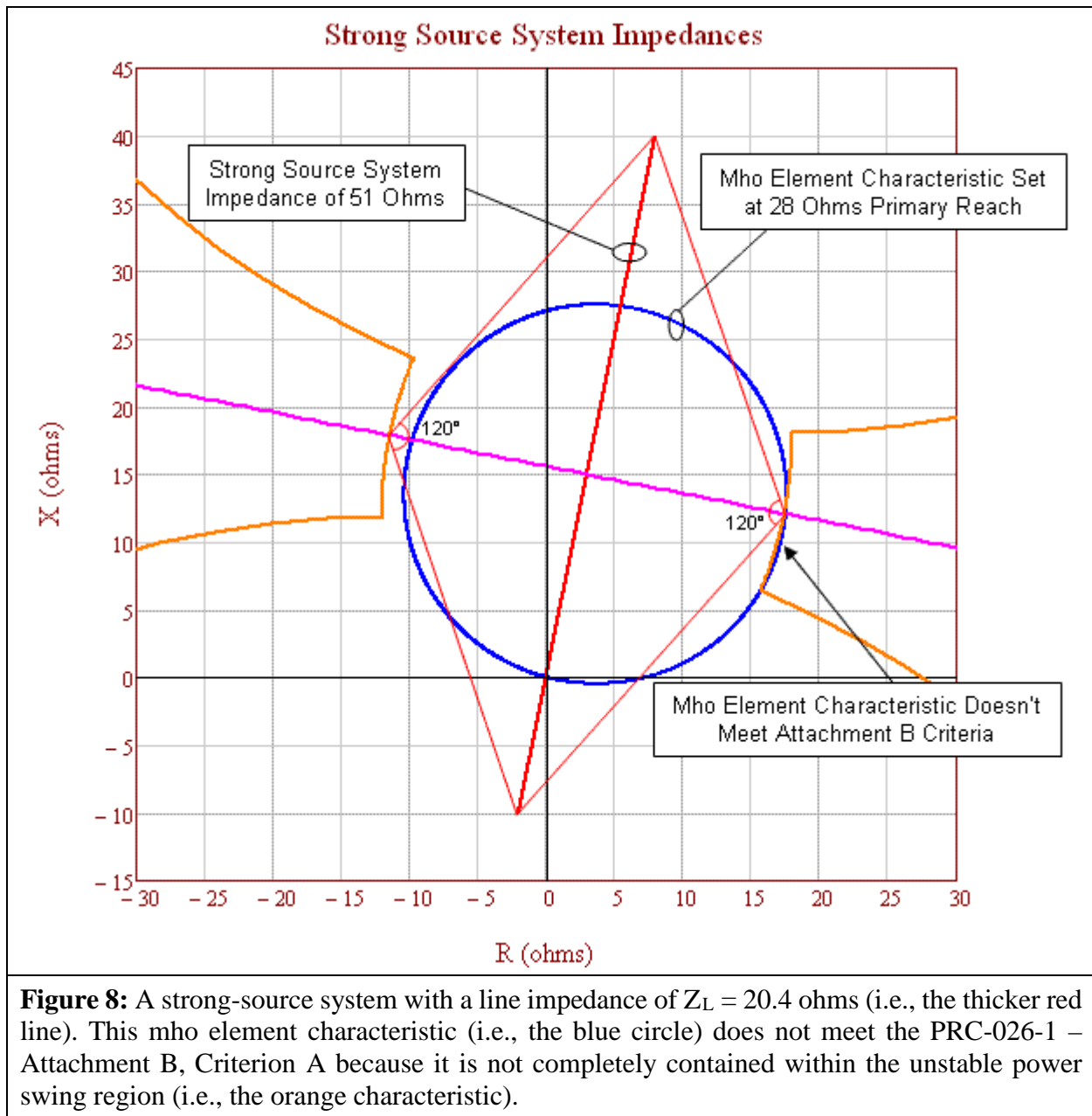
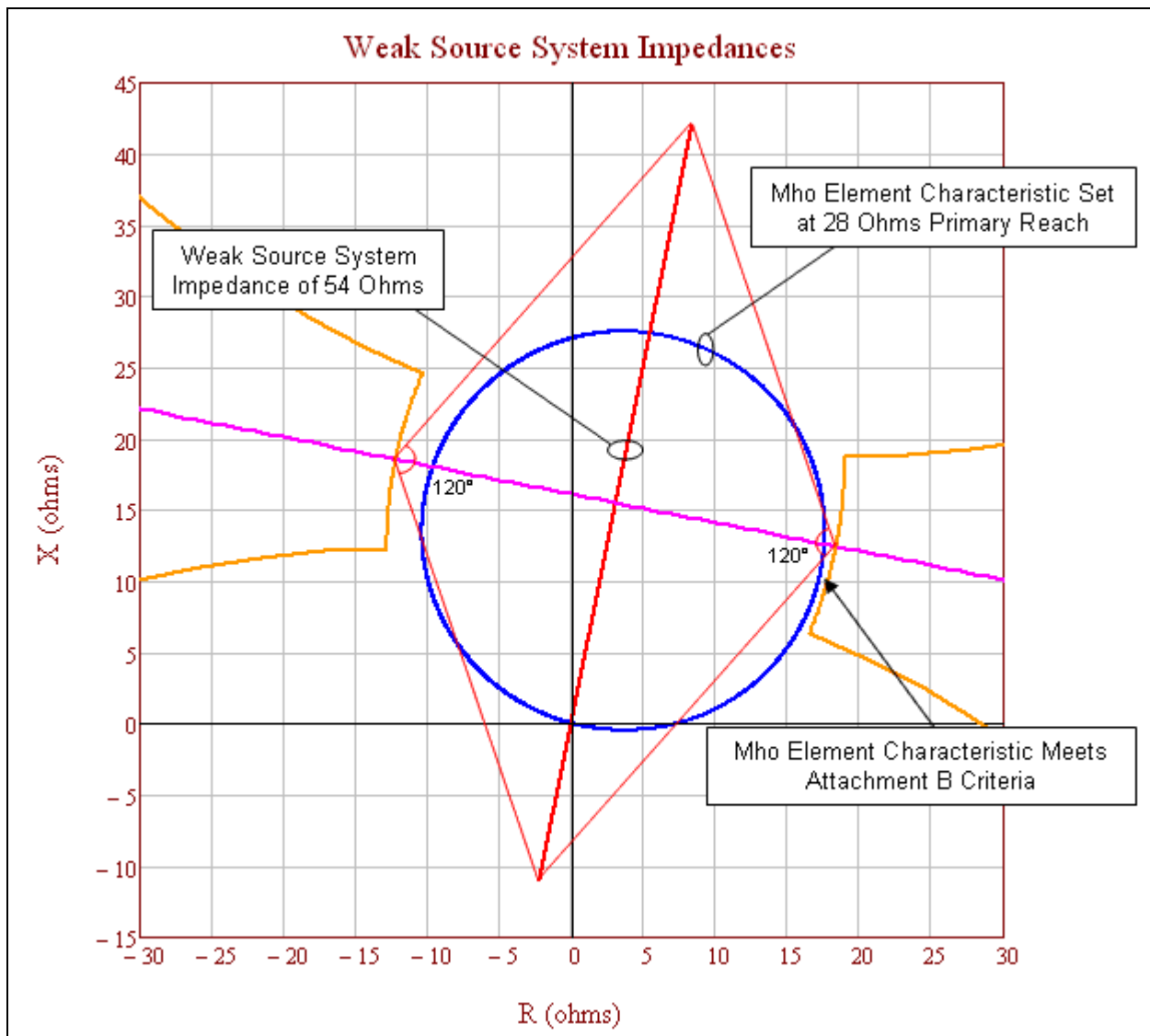
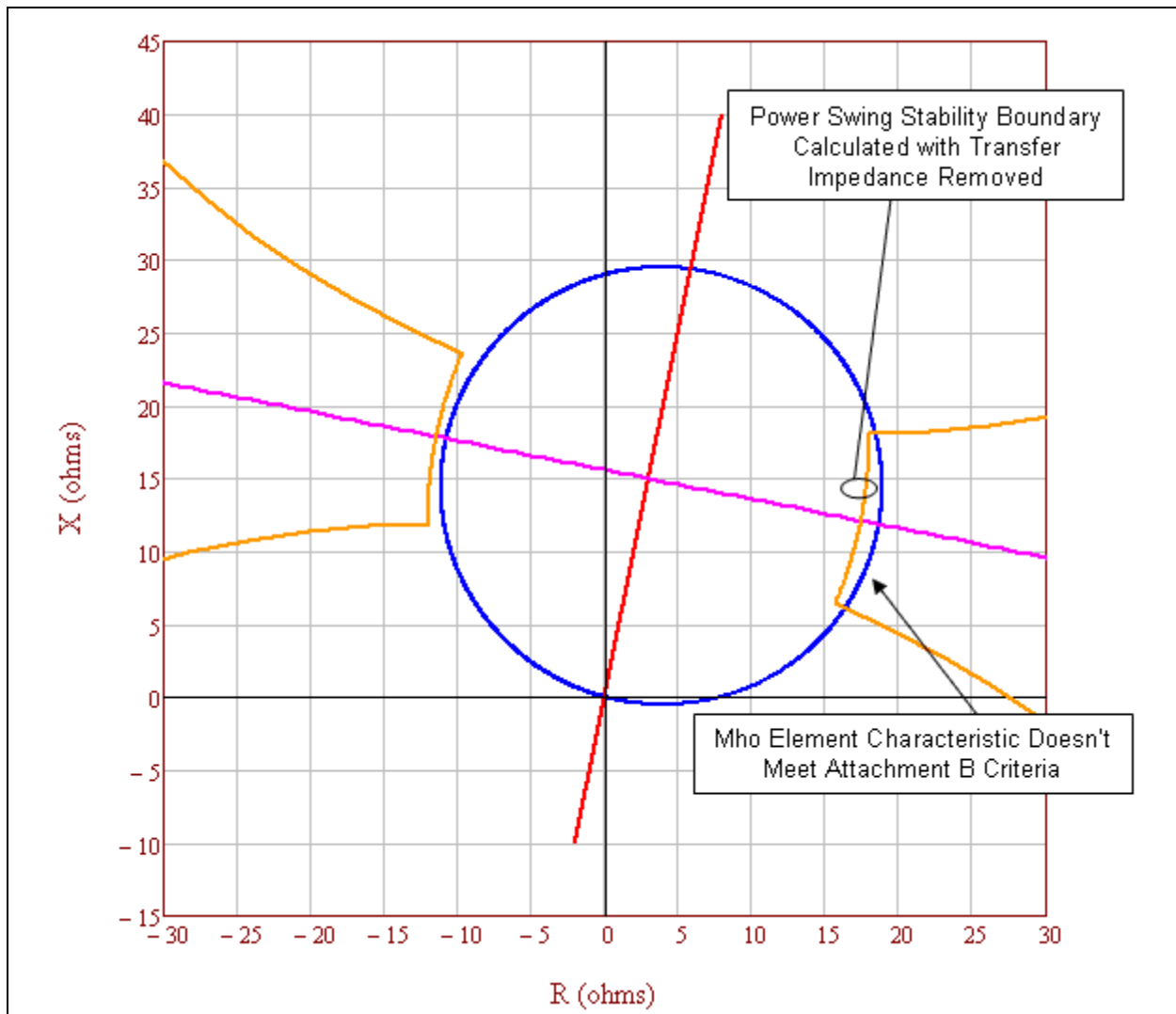


Figure 8 above represents a heavily-loaded system with all generation in service and all transmission BES Elements in their normal operating state. The mho element characteristic (set at 137% of  $Z_L$ ) extends into the unstable power swing region (i.e., the orange characteristic). Using the strongest source system is more conservative because it shrinks the unstable power swing region, bringing it closer to the mho element characteristic. This figure also graphically represents the effect of a system strengthening over time and this is the reason for re-evaluation if the relay has not been evaluated in the last five calendar years. Figure 9 below depicts a relay that meets the PRC-026-1 – Attachment B, Criterion A. Figure 8 depicts the same relay with the same setting five years later, where each source has strengthened by about 10% and now the same mho element characteristic does not meet Criterion A.



**Figure 9:** A weak-source system with a line impedance of  $Z_L = 20.4$  ohms (i.e., the thicker red line). This mho element characteristic (i.e., the blue circle) meets the PRC-026-1 – Attachment B, Criterion A because it is completely contained within the unstable power swing region (i.e., the orange characteristic).

Figure 9 above represents a lightly-loaded system, using a minimum generation profile. The mho element characteristic (set at 137% of  $Z_L$ ) does not extend into the unstable power swing region (i.e., the orange characteristic). Using a weaker source system expands the unstable power swing region away from the mho element characteristic.

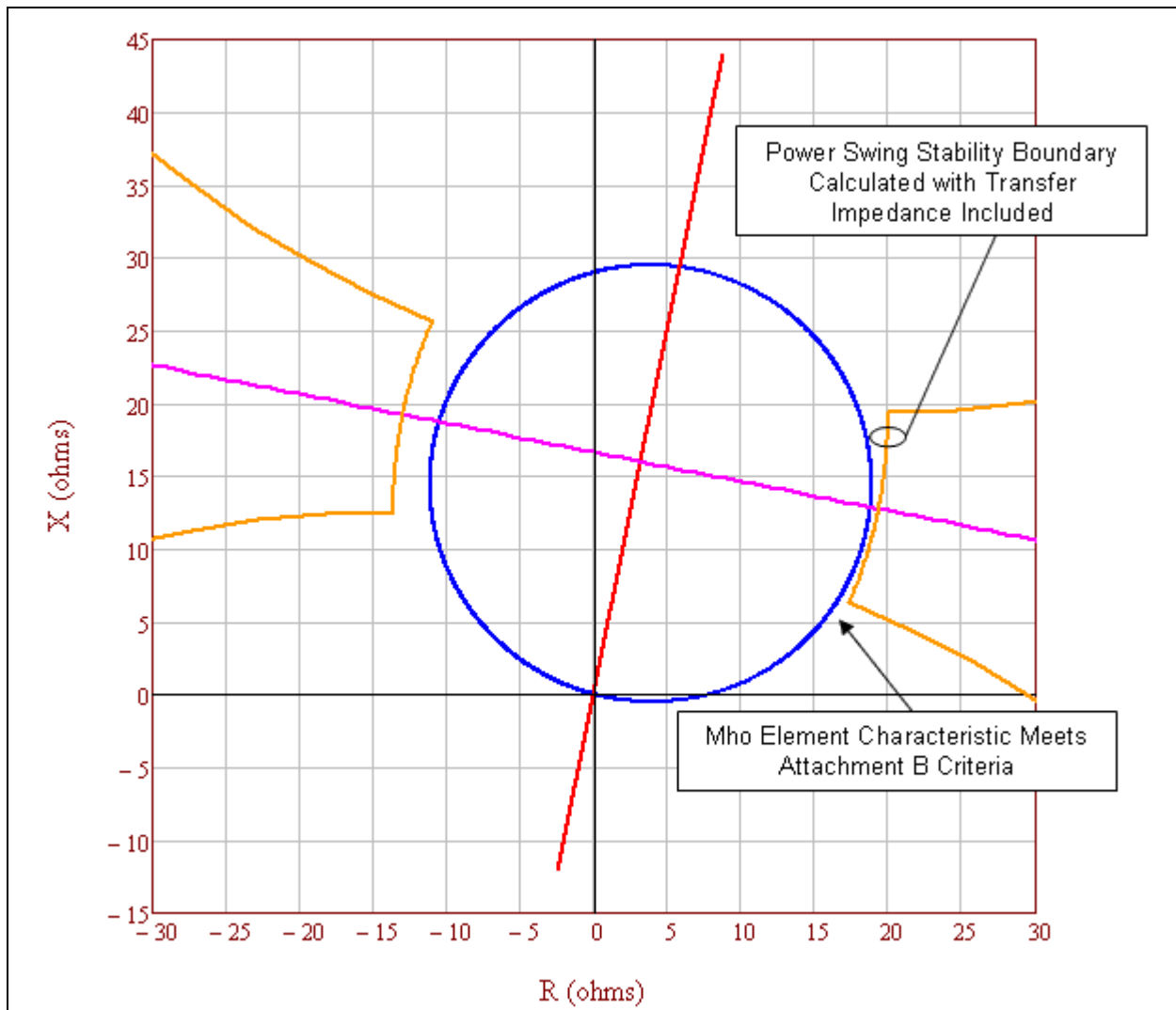


**Figure 10:** This is an example of an unstable power swing region (i.e., the orange characteristic) with the parallel transfer impedance removed. This relay mho element characteristic (i.e., the blue circle) does not meet PRC-026-1 – Attachment B, Criterion A because it is not completely contained within the unstable power swing region.

Table 8: Example Calculation (Parallel Transfer Impedance Removed)	
Calculations for the point at 120 degrees with equal source impedances. The total system current equals the line current. See Figure 10.	
Eq. (54)	$E_S = \frac{V_{LL} \angle 120^\circ}{\sqrt{3}}$
	$E_S = \frac{230,000 \angle 120^\circ V}{\sqrt{3}}$
	$E_S = 132,791 \angle 120^\circ V$

Table 8: Example Calculation (Parallel Transfer Impedance Removed)			
Eq. (55)	$E_R = \frac{V_{LL} \angle 0^\circ}{\sqrt{3}}$		
	$E_R = \frac{230,000 \angle 0^\circ V}{\sqrt{3}}$		
	$E_R = 132,791 \angle 0^\circ V$		
Given impedance data.			
Given:	$Z_S = 2 + j10 \Omega$	$Z_L = 4 + j20 \Omega$	$Z_R = 4 + j20 \Omega$
Given:	$Z_{TR} = Z_L \times 10^{10} \Omega$		
Total impedance between the generators.			
Eq. (56)	$Z_{total} = \frac{(Z_L \times Z_{TR})}{(Z_L + Z_{TR})}$		
	$Z_{total} = \frac{(4 + j20) \Omega \times (4 + j20) \times 10^{10} \Omega}{(4 + j20) \Omega + (4 + j20) \times 10^{10} \Omega}$		
	$Z_{total} = 4 + j20 \Omega$		
Total system impedance.			
Eq. (57)	$Z_{sys} = Z_S + Z_{total} + Z_R$		
	$Z_{sys} = (2 + j10) \Omega + (4 + j20) \Omega + (4 + j20) \Omega$		
	$Z_{sys} = 10 + j50 \Omega$		
Total system current from sending-end source.			
Eq. (58)	$I_{sys} = \frac{E_S - E_R}{Z_{sys}}$		
	$I_{sys} = \frac{132,791 \angle 120^\circ V - 132,791 \angle 0^\circ V}{10 + j50 \Omega}$		
	$I_{sys} = 4,511 \angle 71.3^\circ A$		
The current, as measured by the relay on $Z_L$ (Figure 3), is only the current flowing through that line as determined by using the current divider equation.			
Eq. (59)	$I_L = I_{sys} \times \frac{Z_{TR}}{Z_L + Z_{TR}}$		
	$I_L = 4,511 \angle 71.3^\circ A \times \frac{(4 + j20) \times 10^{10} \Omega}{(4 + j20) \Omega + (4 + j20) \times 10^{10} \Omega}$		
	$I_L = 4,511 \angle 71.3^\circ A$		

Table 8: Example Calculation (Parallel Transfer Impedance Removed)	
The voltage, as measured by the relay on $Z_L$ (Figure 3), is the voltage drop from the sending-end source through the sending-end source impedance.	
Eq. (60)	$V_S = E_S - (Z_S \times I_{sys})$
	$V_S = 132,791 \angle 120^\circ V - [(2 + j10 \Omega) \times 4,511 \angle 71.3^\circ A]$
	$V_S = 95,757 \angle 106.1^\circ V$
The impedance seen by the relay on $Z_L$ .	
Eq. (61)	$Z_{L-Relay} = \frac{V_S}{I_L}$
	$Z_{L-Relay} = \frac{95,757 \angle 106.1^\circ V}{4,511 \angle 71.3^\circ A}$
	$Z_{L-Relay} = 17.434 + j12.113 \Omega$



**Figure 11:** This is an example of an unstable power swing region (i.e., the orange characteristic) with the parallel transfer impedance included causing the mho element characteristic (i.e., the blue circle) to appear to meet the PRC-026-1 – Attachment B, Criterion A because it is completely contained within the unstable power swing region. Including the parallel transfer impedance in the calculation is not allowed by the PRC-026-1 – Attachment B, Criterion A.

In Figure 11 above, the parallel transfer impedance is 5 times the line impedance. The unstable power swing region has expanded out beyond the mho element characteristic due to the infeed effect from the parallel current through the parallel transfer impedance, thus allowing the mho element characteristic to appear to meet the PRC-026-1 – Attachment B, Criterion A. Including the parallel transfer impedance in the calculation is not allowed by the PRC-026-1 – Attachment B, Criterion A.

Table 9: Example Calculation (Parallel Transfer Impedance Included)			
Calculations for the point at 120 degrees with equal source impedances. The total system current does not equal the line current. See Figure 11.			
Eq. (62)	$E_S = \frac{V_{LL} \angle 120^\circ}{\sqrt{3}}$		
	$E_S = \frac{230,000 \angle 120^\circ V}{\sqrt{3}}$		
	$E_S = 132,791 \angle 120^\circ V$		
Eq. (63)	$E_R = \frac{V_{LL} \angle 0^\circ}{\sqrt{3}}$		
	$E_R = \frac{230,000 \angle 0^\circ V}{\sqrt{3}}$		
	$E_R = 132,791 \angle 0^\circ V$		
Given impedance data.			
Given:	$Z_S = 2 + j10 \Omega$	$Z_L = 4 + j20 \Omega$	$Z_R = 4 + j20 \Omega$
Given:	$Z_{TR} = Z_L \times 5$		
	$Z_{TR} = (4 + j20) \Omega \times 5$		
	$Z_{TR} = 20 + j100 \Omega$		
Total impedance between the generators.			
Eq. (64)	$Z_{total} = \frac{(Z_L \times Z_{TR})}{(Z_L + Z_{TR})}$		
	$Z_{total} = \frac{(4 + j20) \Omega \times (20 + j100) \Omega}{(4 + j20) \Omega + (20 + j100) \Omega}$		
	$Z_{total} = 3.333 + j16.667 \Omega$		
Total system impedance.			
Eq. (65)	$Z_{sys} = Z_S + Z_{total} + Z_R$		
	$Z_{sys} = (2 + j10) \Omega + (3.333 + j16.667) \Omega + (4 + j20) \Omega$		
	$Z_{sys} = 9.333 + j46.667 \Omega$		
Total system current from sending-end source.			
Eq. (66)	$I_{sys} = \frac{E_S - E_R}{Z_{sys}}$		
	$I_{sys} = \frac{132,791 \angle 120^\circ V - 132,791 \angle 0^\circ V}{9.333 + j46.667 \Omega}$		

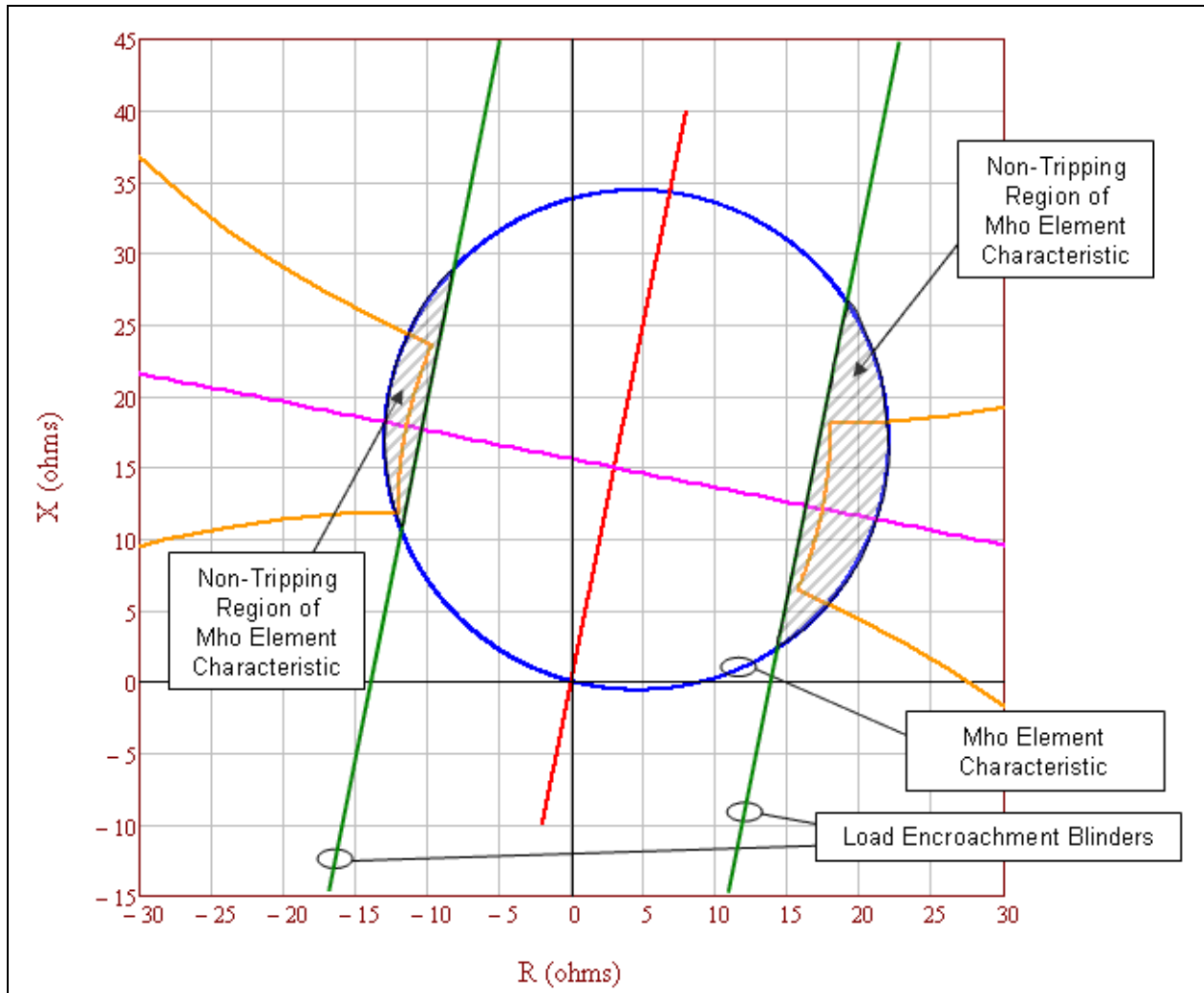


Table 9: Example Calculation (Parallel Transfer Impedance Included)	
	$I_{sys} = 4,833 \angle 71.3^\circ A$
The current, as measured by the relay on $Z_L$ (Figure 3), is only the current flowing through that line as determined by using the current divider equation.	
Eq. (67)	$I_L = I_{sys} \times \frac{Z_{TR}}{Z_L + Z_{TR}}$
	$I_L = 4,833 \angle 71.3^\circ A \times \frac{(20 + j100) \Omega}{(4 + j20) \Omega + (20 + j100) \Omega}$
	$I_L = 4,027.4 \angle 71.3^\circ A$
The voltage, as measured by the relay on $Z_L$ (Figure 3), is the voltage drop from the sending-end source through the sending-end source impedance.	
Eq. (68)	$V_S = E_S - (Z_S \times I_{sys})$
	$V_S = 132,791 \angle 120^\circ V - [(2 + j10 \Omega) \times 4,833 \angle 71.3^\circ A]$
	$V_S = 93,417 \angle 104.7^\circ V$
The impedance seen by the relay on $Z_L$ .	
Eq. (69)	$Z_{L-Relay} = \frac{V_S}{I_L}$
	$Z_{L-Relay} = \frac{93,417 \angle 104.7^\circ V}{4,027 \angle 71.3^\circ A}$
	$Z_{L-Relay} = 19.366 + j12.767 \Omega$

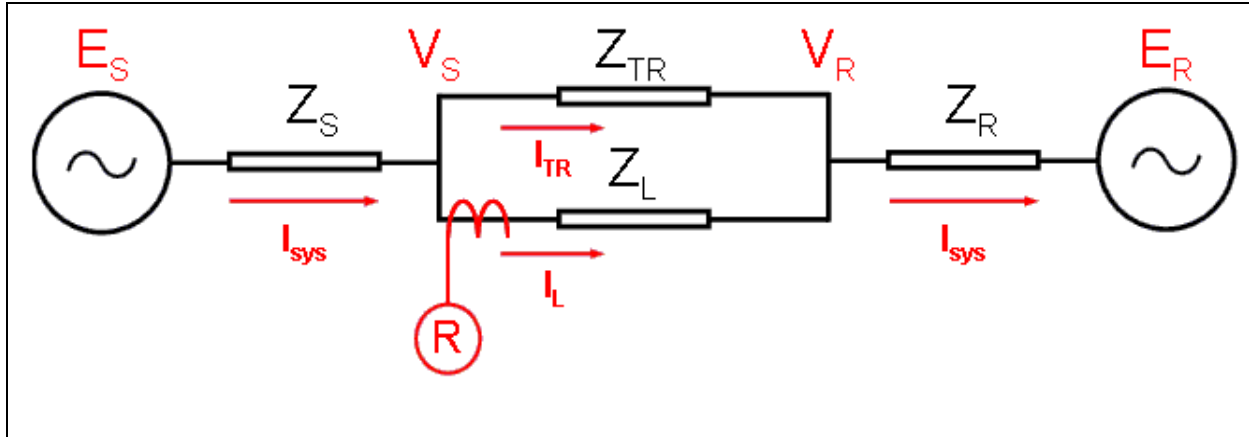
**Table 10: Percent Increase of a Lens Due To Parallel Transfer Impedance.**

The following demonstrates the percent size increase of the lens characteristic for  $Z_{TR}$  in multiples of  $Z_L$  with the parallel transfer impedance included.

$Z_{TR}$ in multiples of $Z_L$	Percent increase of lens with equal EMF sources (Infinite source as reference)
Infinite	N/A
1000	0.05%
100	0.46%
10	4.63%
5	9.27%
2	23.26%
1	46.76%
0.5	94.14%
0.25	189.56%



**Figure 12:** The tripping portion of the mho element characteristic (i.e., the blue circle) not blocked by load encroachment (i.e., the parallel green lines) is completely contained within the unstable power swing region (i.e., the orange characteristic). Therefore, the mho element characteristic meets the PRC-026-1 – Attachment B, Criterion A.



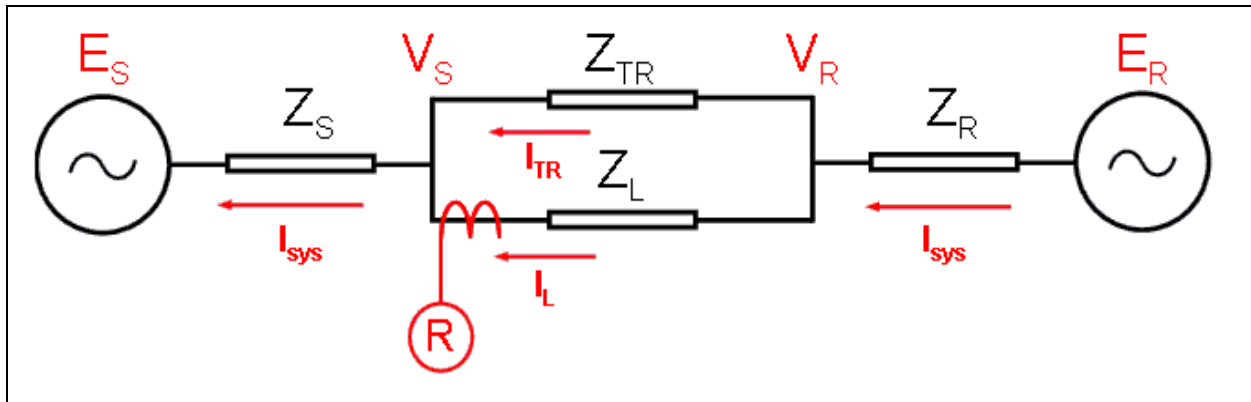
**Figure 13:** The infeed diagram shows the impedance in front of the relay R with the parallel transfer impedance included. As the parallel transfer impedance approaches infinity, the impedances seen by the relay R in the forward direction becomes  $Z_L + Z_R$ .

**Table 11: Calculations (System Apparent Impedance in the forward direction)**

The following equations are provided for calculating the apparent impedance back to the  $E_R$  source voltage as seen by relay R. Infeed equations from  $V_S$  to source  $E_R$  where  $E_R = 0$ . See Figure 13.

Eq. (70)	$I_L = \frac{V_S - V_R}{Z_L}$			
Eq. (71)	$I_{sys} = \frac{V_R - E_R}{Z_R}$			
Eq. (72)	$I_{sys} = I_L + I_{TR}$			
Eq. (73)	$I_{sys} = \frac{V_R}{Z_R}$	Since $E_R = 0$	Rearranged:	$V_R = I_{sys} \times Z_R$
Eq. (74)	$I_L = \frac{V_S - I_{sys} \times Z_R}{Z_L}$			
Eq. (75)	$I_L = \frac{V_S - [(I_L + I_{TR}) \times Z_R]}{Z_L}$			
Eq. (76)	$V_S = (I_L \times Z_L) + (I_L \times Z_R) + (I_{TR} \times Z_R)$			
Eq. (77)	$Z_{Relay} = \frac{V_S}{I_L} = Z_L + Z_R + \frac{I_{TR} \times Z_R}{I_L} = Z_L + Z_R \times \left(1 + \frac{I_{TR}}{I_L}\right)$			
Eq. (78)	$I_{TR} = I_{sys} \times \frac{Z_L}{Z_L + Z_{TR}}$			
Eq. (79)	$I_L = I_{sys} \times \frac{Z_{TR}}{Z_L + Z_{TR}}$			

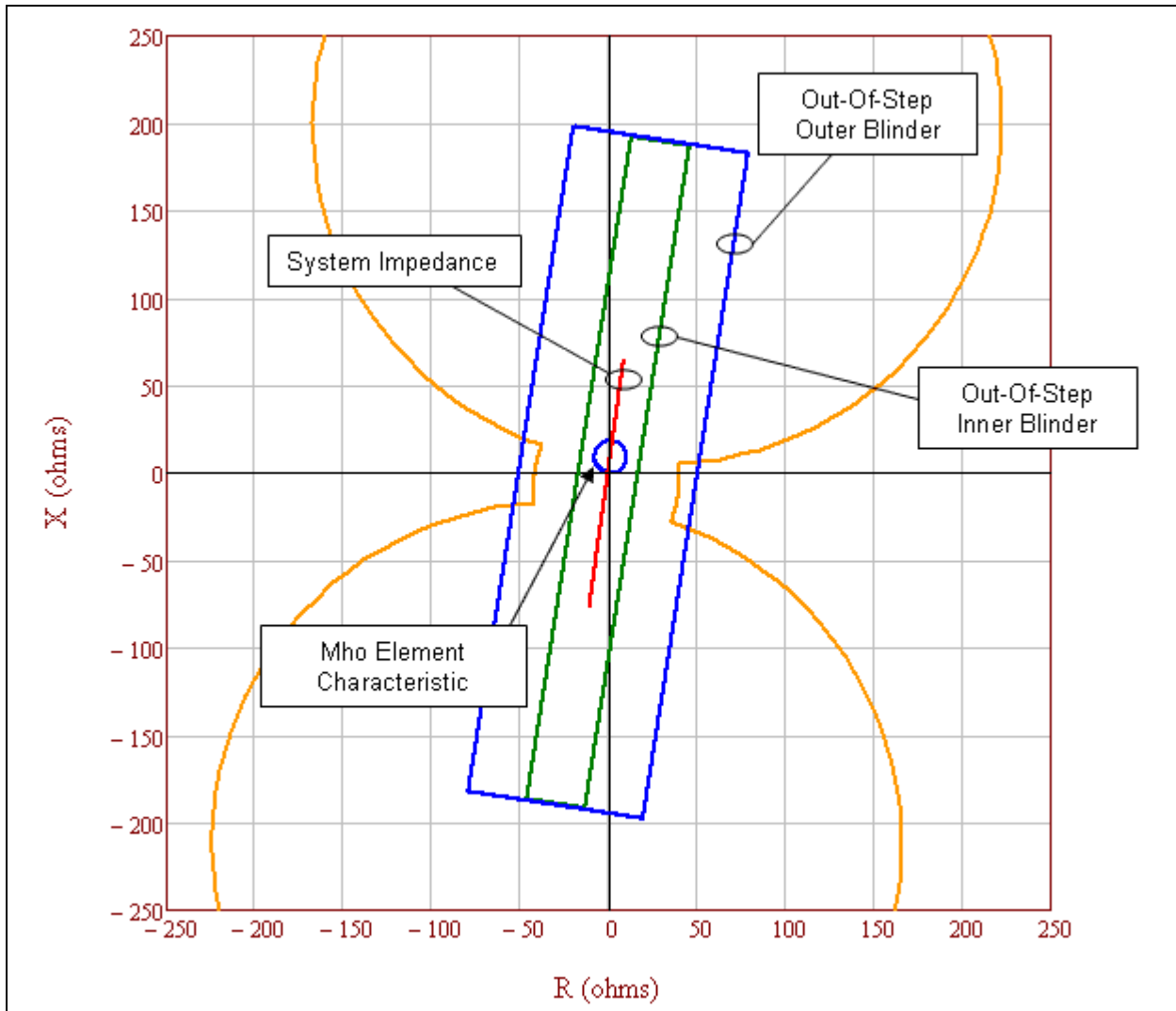
Table 11: Calculations (System Apparent Impedance in the forward direction)	
Eq. (80)	$\frac{I_{TR}}{I_L} = \frac{Z_L}{Z_{TR}}$
The infeed equations shows the impedance in front of the relay R (Figure 13) with the parallel transfer impedance included. As the parallel transfer impedance approaches infinity, the impedances seen by the relay R in the forward direction becomes $Z_L + Z_R$ .	
Eq. (81)	$Z_{Relay} = Z_L + Z_R \times \left(1 + \frac{Z_L}{Z_{TR}}\right)$



**Figure 14:** The infeed diagram shows the impedance behind relay R with the parallel transfer impedance included. As the parallel transfer impedance approaches infinity, the impedances seen by the relay R in the reverse direction becomes  $Z_S$ .

Table 12: Calculations (System Apparent Impedance in the Reverse Direction)				
The following equations are provided for calculating the apparent impedance back to the $E_S$ source voltage as seen by relay R. Infeed equations from $V_R$ back to source $E_S$ where $E_S = 0$ . See Figure 14.				
Eq. (82)	$I_L = \frac{V_R - V_S}{Z_L}$			
Eq. (83)	$I_{sys} = \frac{V_S - E_S}{Z_S}$			
Eq. (84)	$I_{sys} = I_L + I_{TR}$			
Eq. (85)	$I_{sys} = \frac{V_S}{Z_S}$	Since $E_S = 0$	Rearranged:	$V_S = I_{sys} \times Z_S$
Eq. (86)	$I_L = \frac{V_R - I_{sys} \times Z_S}{Z_L}$			

Table 12: Calculations (System Apparent Impedance in the Reverse Direction)		
Eq. (87)	$I_L = \frac{V_R - [(I_L + I_{TR}) \times Z_S]}{Z_L}$	
Eq. (88)	$V_R = (I_L \times Z_L) + (I_L \times Z_S) + (I_{TR} \times Z_{RS})$	
Eq. (89)	$Z_{Relay} = \frac{V_R}{I_L} = Z_L + Z_S + \frac{I_{TR} \times Z_S}{I_L} = Z_L + Z_S \times \left(1 + \frac{I_{TR}}{I_L}\right)$	
Eq. (90)	$I_{TR} = I_{sys} \times \frac{Z_L}{Z_L + Z_{TR}}$	
Eq. (91)	$I_L = I_{sys} \times \frac{Z_{TR}}{Z_L + Z_{TR}}$	
Eq. (92)	$\frac{I_{TR}}{I_L} = \frac{Z_L}{Z_{TR}}$	
The infeed equations shows the impedance behind relay R (Figure 14) with the parallel transfer impedance included. As the parallel transfer impedance approaches infinity, the impedances seen by the relay R in the reverse direction becomes $Z_S$ .		
Eq. (93)	$Z_{Relay} = Z_L + Z_S \times \left(1 + \frac{Z_L}{Z_{TR}}\right)$	As seen by relay R at the receiving-end of the line.
Eq. (94)	$Z_{Relay} = Z_S \times \left(1 + \frac{Z_L}{Z_{TR}}\right)$	Subtract $Z_L$ for relay R impedance as seen at sending-end of the line.



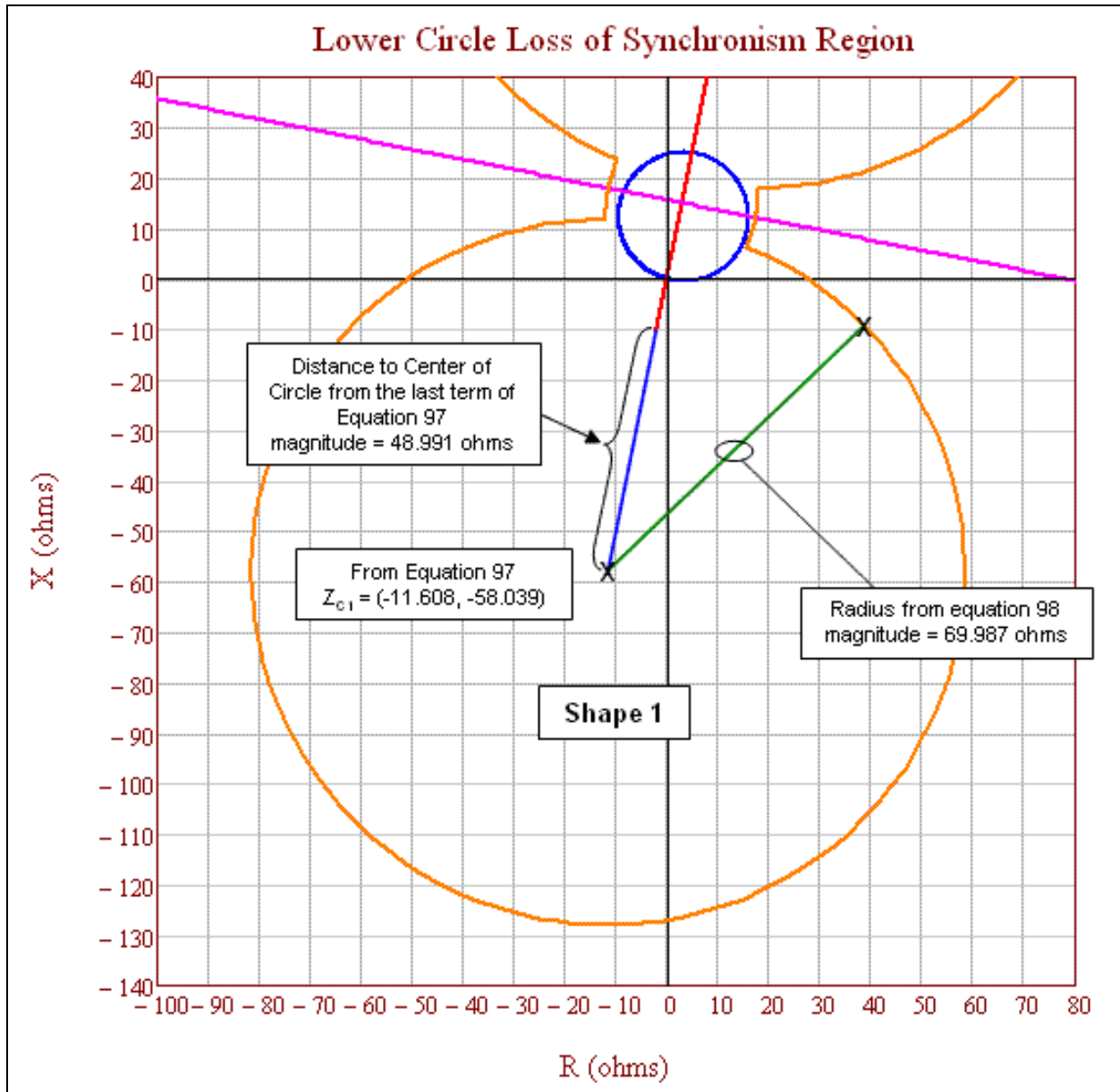
**Figure 15:** Out-of-step trip (OST) inner blinder (i.e., the parallel green lines) meets the PRC-026-1 – Attachment B, Criterion A because the inner OST blinder initiates tripping either On-The-Way-In or On-The-Way-Out. Since the inner blinder is completely contained within the unstable power swing region (i.e., the orange characteristic), it meets the PRC-026-1 – Attachment B, Criterion A.

Table 13: Example Calculation (Voltage Ratios)			
These calculations are based on the loss-of-synchronism characteristics for the cases of $N < 1$ and $N > 1$ as found in the <i>Application of Out-of-Step Blocking and Tripping Relays</i> , GER-3180, p. 12, Figure 3. <sup>19</sup> The GE illustration shows the formulae used to calculate the radius and center of the circles that make up the ends of the portion of the lens.			
Voltage ratio equations, source impedance equation with infeed formulae applied, and circle equations.			
Given:	$E_S = 0.7$	$E_R = 1.0$	
Eq. (95)	$N = \frac{ E_S }{ E_R } = \frac{0.7}{1.0} = 0.7$		
The total system impedance as seen by the relay with infeed formulae applied.			
Given:	$Z_S = 2 + j10 \Omega$	$Z_L = 4 + j20 \Omega$	$Z_R = 4 + j20 \Omega$
Given:	$Z_{TR} = Z_L \times 10^{10} \Omega$		
	$Z_{TR} = (4 + j20) \times 10^{10} \Omega$		
Eq. (96)	$Z_{sys} = Z_S \times \left(1 + \frac{Z_L}{Z_{TR}}\right) + \left[Z_L + Z_R \times \left(1 + \frac{Z_L}{Z_{TR}}\right)\right]$		
	$Z_{sys} = 10 + j50 \Omega$		
The calculated coordinates of the lower loss-of-synchronism circle center.			
Eq. (97)	$Z_{C1} = - \left[ Z_S \times \left(1 + \frac{Z_L}{Z_{TR}}\right) \right] - \left[ \frac{N^2 \times Z_{sys}}{1 - N^2} \right]$		
	$Z_{C1} = - \left[ (2 + j10) \Omega \times \left(1 + \frac{(4 + j20) \Omega}{(4 + j20) \times 10^{10} \Omega}\right) \right] - \left[ \frac{0.7^2 \times (10 + j50) \Omega}{1 - 0.7^2} \right]$		
	$Z_{C1} = -11.608 - j58.039 \Omega$		
The calculated radius of the lower loss-of-synchronism circle.			
Eq. (98)	$r_a = \left  \frac{N \times Z_{sys}}{1 - N^2} \right $		
	$r_a = \left  \frac{0.7 \times (10 + j50) \Omega}{1 - 0.7^2} \right $		
	$r_a = 69.987 \Omega$		
The calculated coordinates of the upper loss-of-synchronism circle center.			
Given:	$E_S = 1.0$	$E_R = 0.7$	

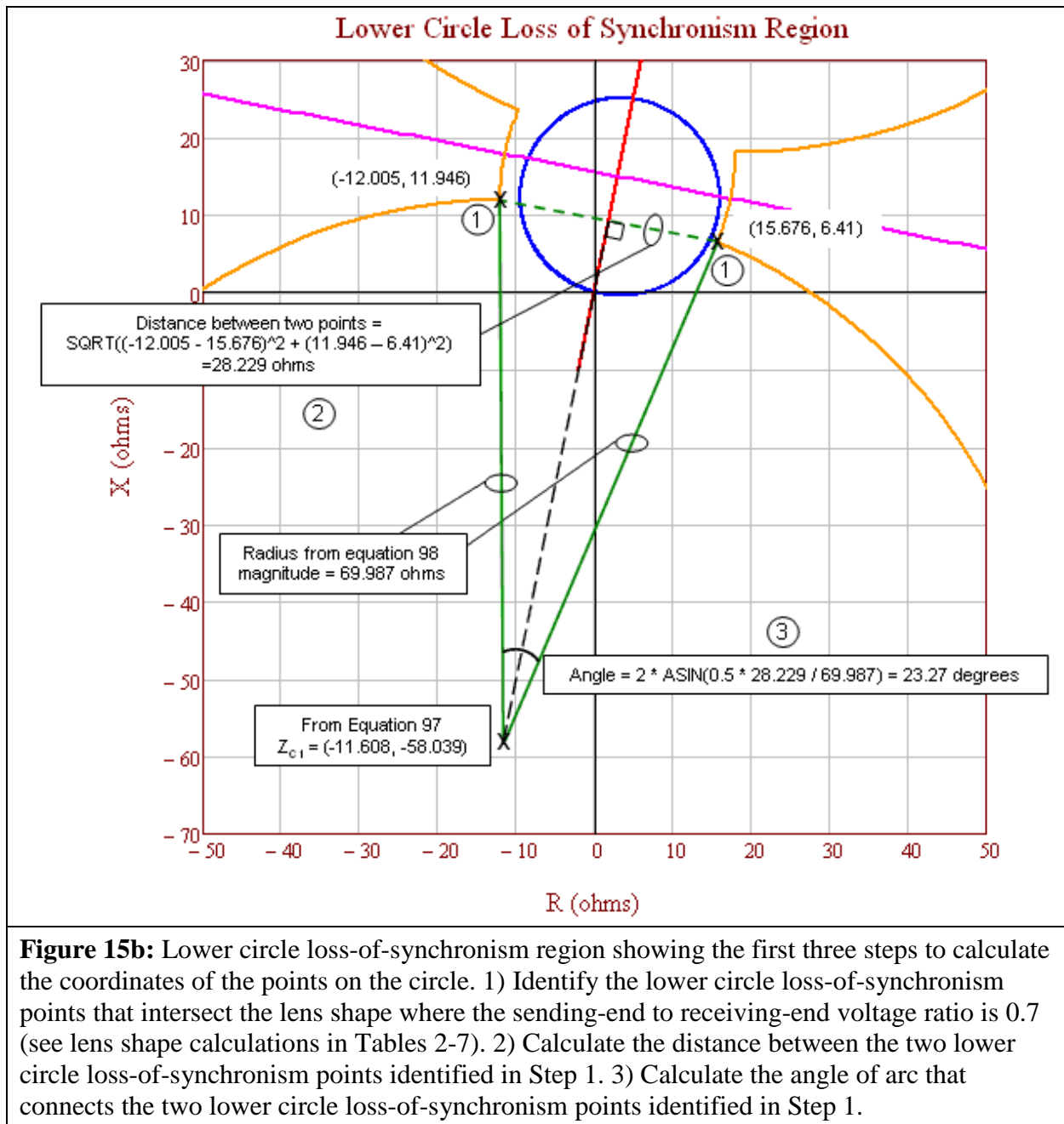
<sup>19</sup> <http://store.gedigitalenergy.com/faq/Documents/Alps/GER-3180.pdf>



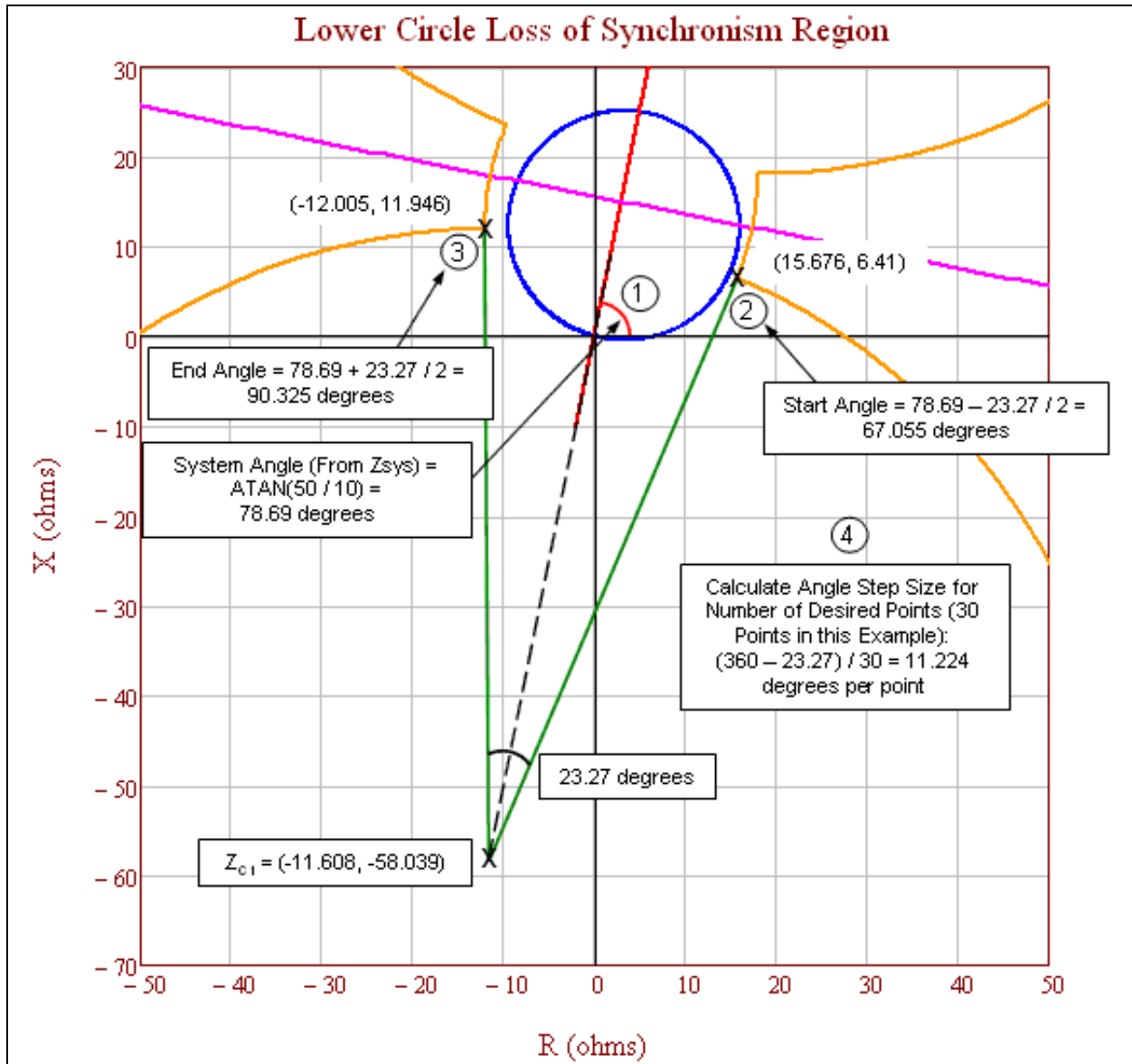
Table 13: Example Calculation (Voltage Ratios)	
Eq. (99)	$N = \frac{ E_S }{ E_R } = \frac{1.0}{0.7} = 1.43$
Eq. (100)	$Z_{C2} = Z_L + \left[ Z_R \times \left( 1 + \frac{Z_L}{Z_{TR}} \right) \right] + \left[ \frac{Z_{sys}}{N^2 - 1} \right]$
	$Z_{C2} = 4 + j20 \Omega + \left[ (4 + j20) \Omega \times \left( 1 + \frac{(4 + j20) \Omega}{(4 + j20) \times 10^{10} \Omega} \right) \right] + \left[ \frac{(10 + j50) \Omega}{1.43^2 - 1} \right]$
	$Z_{C2} = 17.608 + j88.039 \Omega$
The calculated radius of the upper loss-of-synchronism circle.	
Eq. (101)	$r_b = \left  \frac{N \times Z_{sys}}{N^2 - 1} \right $
	$r_b = \left  \frac{1.43 \times (10 + j50) \Omega}{1.43^2 - 1} \right $
	$r_b = 69.987 \Omega$



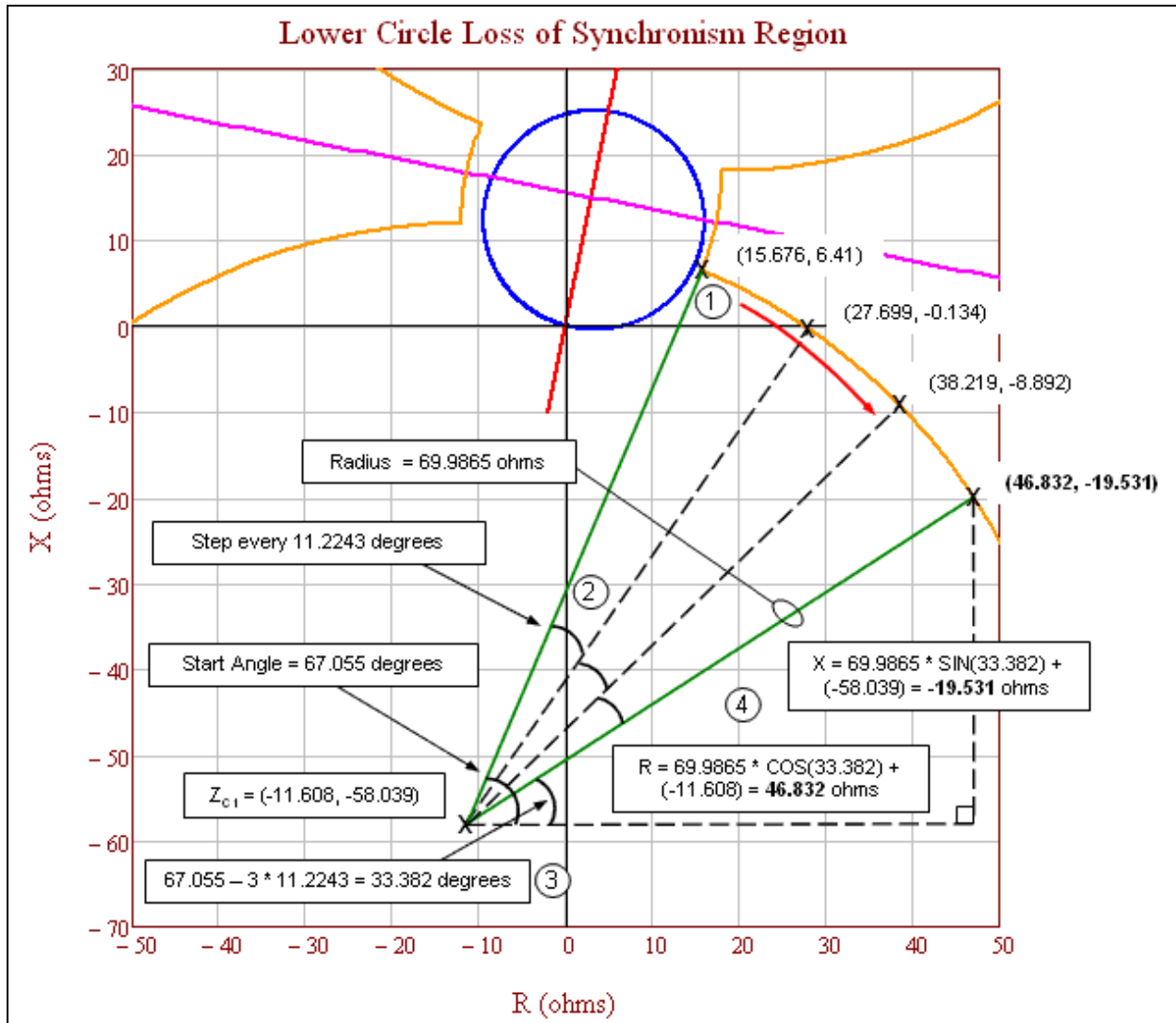
**Figure 15a:** Lower circle loss-of-synchronism region showing the coordinates of the circle center and the circle radius.



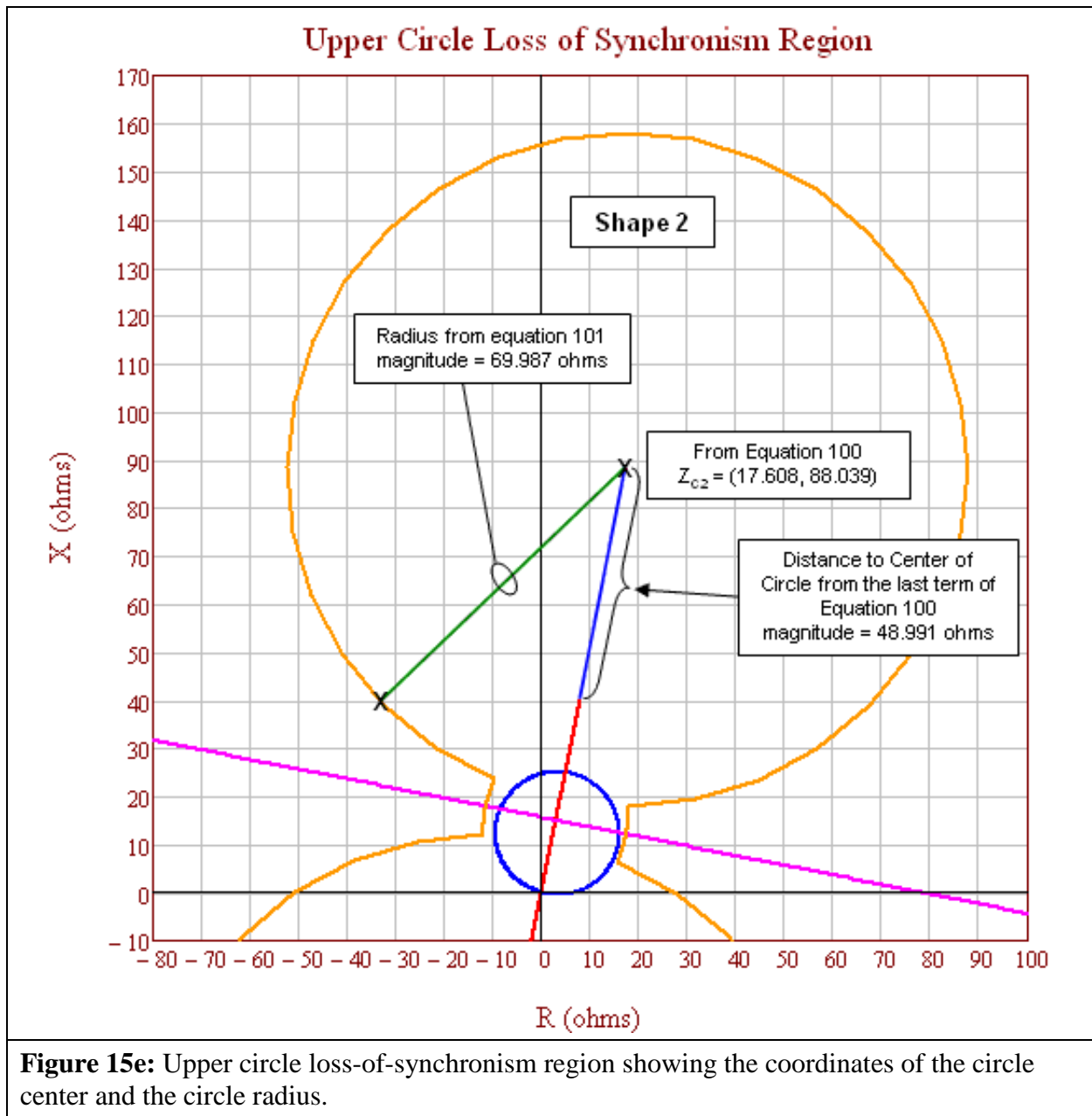
**Figure 15b:** Lower circle loss-of-synchronism region showing the first three steps to calculate the coordinates of the points on the circle. 1) Identify the lower circle loss-of-synchronism points that intersect the lens shape where the sending-end to receiving-end voltage ratio is 0.7 (see lens shape calculations in Tables 2-7). 2) Calculate the distance between the two lower circle loss-of-synchronism points identified in Step 1. 3) Calculate the angle of arc that connects the two lower circle loss-of-synchronism points identified in Step 1.



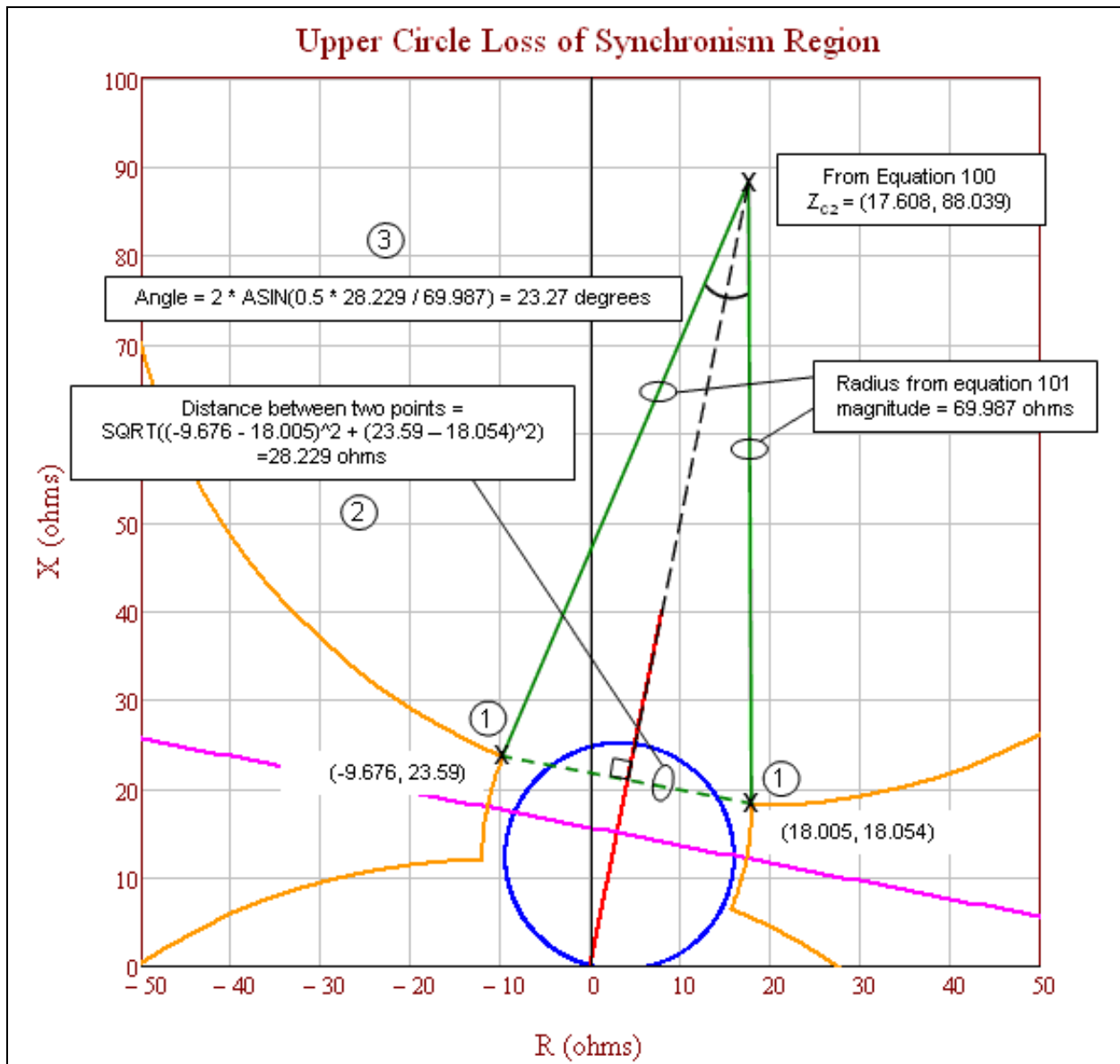
**Figure 15c:** Lower circle loss-of-synchronism region showing the steps to calculate the start angle, end angle, and the angle step size for the desired number of calculated points. 1) Calculate the system angle. 2) Calculate the start angle. 3) Calculate the end angle. 4) Calculate the angle step size for the desired number of points.



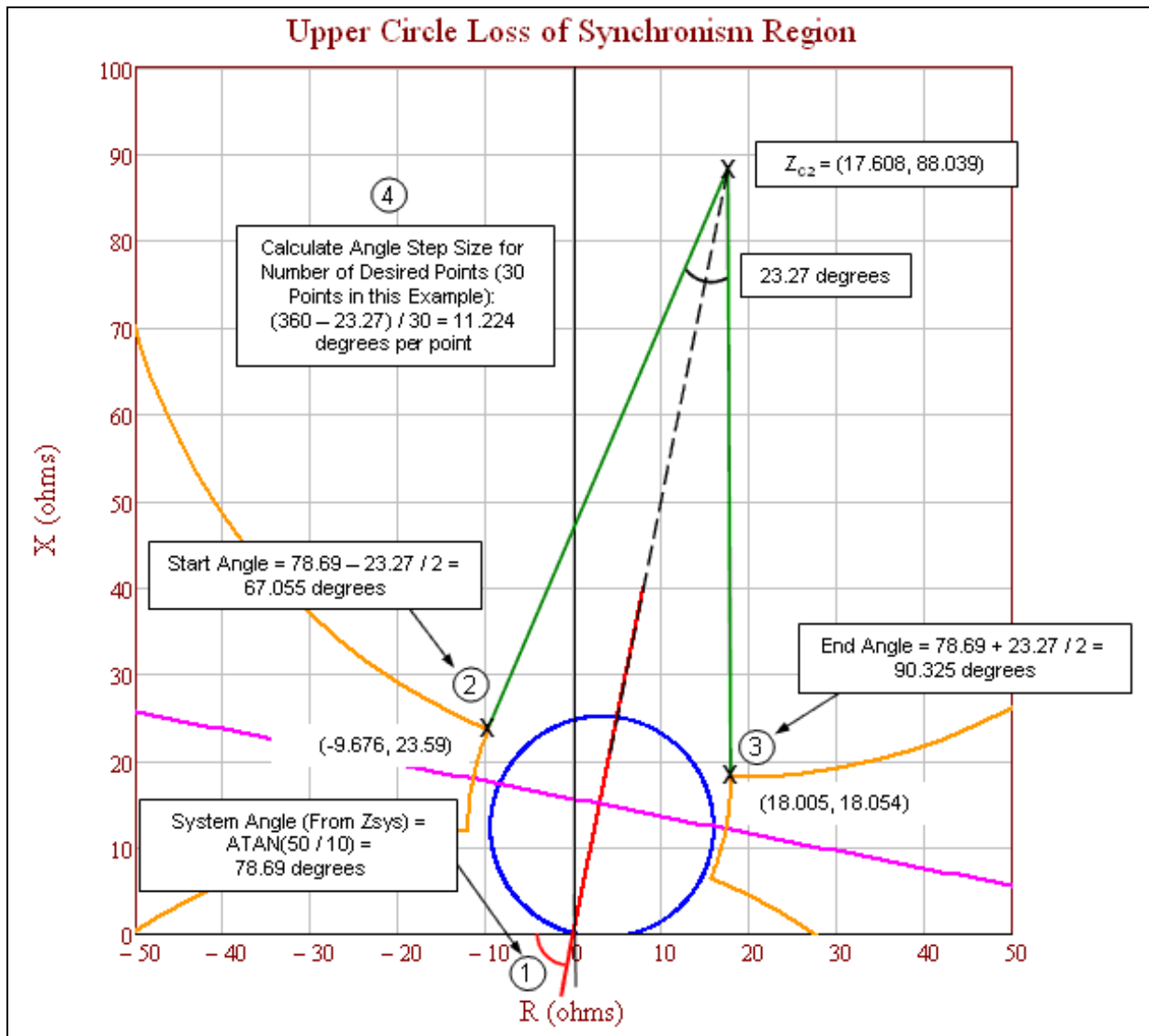
**Figure 15d:** Lower circle loss-of-synchronism region showing the final steps to calculate the coordinates of the points on the circle. 1) Start at the intersection with the lens shape and proceed in a clockwise direction. 2) Advance the step angle for each point. 3) Calculate the new angle after step advancement. 4) Calculate the R–X coordinates.



**Figure 15e:** Upper circle loss-of-synchronism region showing the coordinates of the circle center and the circle radius.

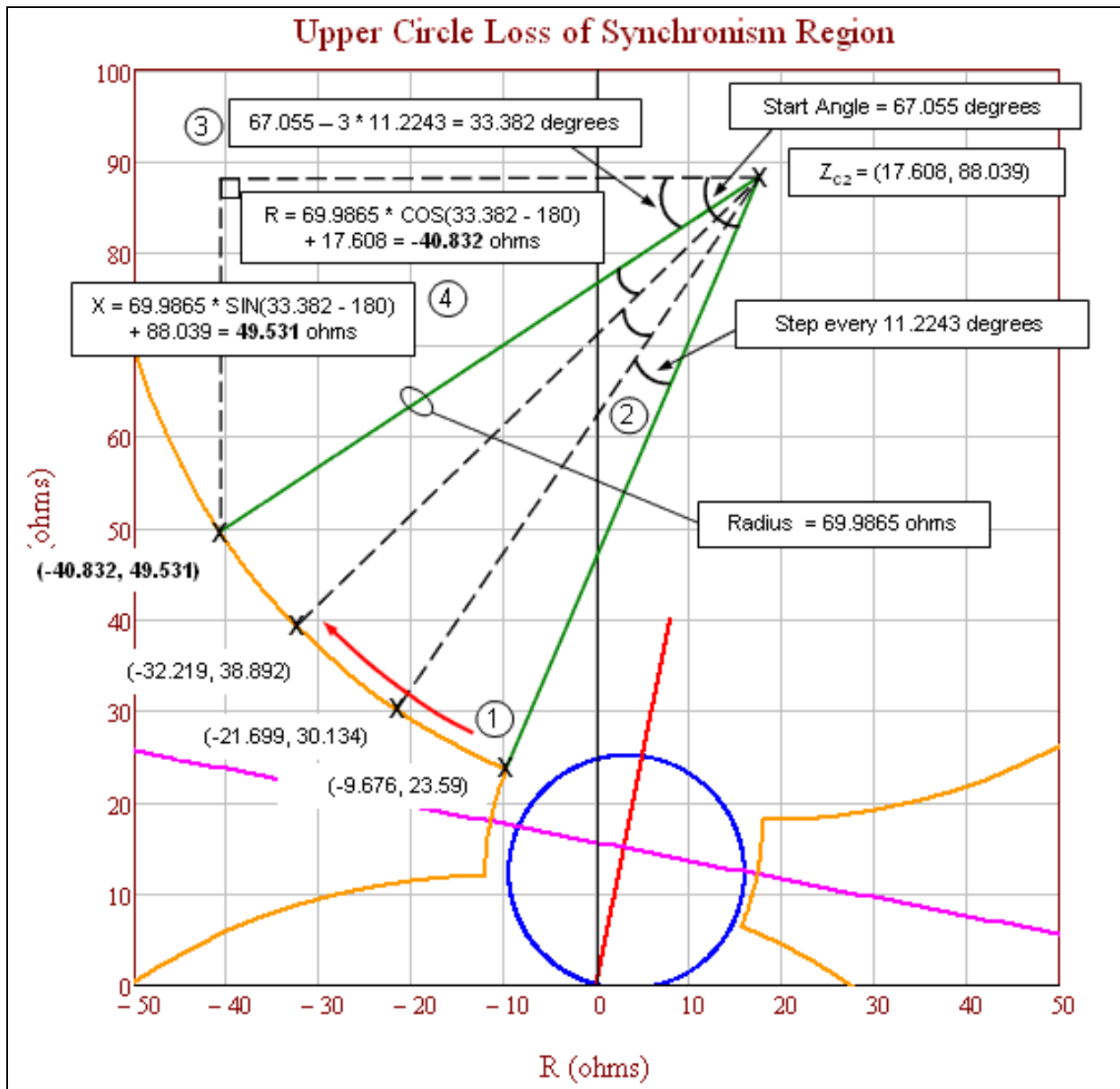


**Figure 15f:** Upper circle loss-of-synchronism region showing the first three steps to calculate the coordinates of the points on the circle. 1) Identify the upper circle points that intersect the lens shape where the sending-end to receiving-end voltage ratio is 1.43 (see lens shape calculations in Tables 2-7). 2) Calculate the distance between the two upper circle points identified in Step 1. 3) Calculate the angle of arc that connects the two upper circle points identified in Step 1.



**Figure 15g:** Upper circle loss-of-synchronism region showing the steps to calculate the start angle, end angle, and the angle step size for the desired number of calculated points. 1) Calculate the system angle. 2) Calculate the start angle. 3) Calculate the end angle. 4) Calculate the angle step size for the desired number of points.





**Figure 15h:** Upper circle loss-of-synchronism region showing the final steps to calculate the coordinates of the points on the circle. 1) Start at the intersection with the lens shape and proceed in a clockwise direction. 2) Advance the step angle for each point. 3) Calculate the new angle after step advancement. 4) Calculate the R-X coordinates.

Lower Loss of Synchronism Circle Coordinates			Upper Loss of Synchronism Circle Coordinates		
Angle (degrees)	R	+ jX	Angle (degrees)	R	+ jX
67.055	15.676	6.41	67.055	-9.676	23.59
55.831	27.699	-0.134	55.831	-21.699	30.134
44.606	38.219	-8.892	44.606	-32.219	38.892
<b>33.382</b>	<b>46.832</b>	<b>-19.531</b>	<b>33.382</b>	<b>-40.832</b>	<b>49.531</b>
22.158	53.21	-31.643	22.158	-47.21	61.643
10.933	57.108	-44.765	10.933	-51.108	74.765
359.709	58.378	-58.395	359.709	-52.378	88.395
348.485	56.97	-72.011	348.485	-50.97	102.011
337.26	52.939	-85.092	337.26	-46.939	115.092
326.036	46.438	-97.139	326.036	-40.438	127.139
314.812	37.717	-107.69	314.812	-31.717	137.69
303.587	27.109	-116.341	303.587	-21.109	146.341
292.363	15.02	-122.762	292.363	-9.02	152.762
281.139	1.913	-126.707	281.139	4.087	156.707
269.914	-11.712	-128.026	269.914	17.712	158.026
258.69	-25.333	-126.667	258.69	31.333	156.667
247.466	-38.429	-122.682	247.466	44.429	152.682
236.241	-50.499	-116.225	236.241	56.499	146.225
225.017	-61.081	-107.542	225.017	67.081	137.542
213.793	-69.771	-96.965	213.793	75.771	126.965
202.568	-76.235	-84.899	202.568	82.235	114.899
191.344	-80.227	-71.806	191.344	86.227	101.806
180.12	-81.594	-58.185	180.12	87.594	88.185
168.895	-80.284	-44.56	168.895	86.284	74.56
157.671	-76.347	-31.45	157.671	82.347	61.45
146.447	-69.933	-19.357	146.447	75.933	49.357
135.222	-61.288	-8.744	135.222	67.288	38.744
123.998	-50.742	-0.016	123.998	56.742	30.016
112.774	-38.699	6.491	112.774	44.699	23.509
101.549	-25.62	10.53	101.549	31.62	19.47
90.325	-12.005	11.946	90.325	18.005	18.054

**Figure 15i:** Full tables of calculated lower and upper loss-of-synchronism circle coordinates. The highlighted row is the detailed calculated points in Figures 15d and 15h.

### Application Specific to Criterion B

The PRC-026-1 – Attachment B, Criterion B evaluates overcurrent elements used for tripping. The same criteria as PRC-026-1 – Attachment B, Criterion A is used except for an additional criterion (No. 4) that calculates a current magnitude based upon generator internal voltage of 1.05 per unit. A value of 1.05 per unit generator voltage is used to establish a minimum pickup current value for overcurrent relays that have a time delay less than 15 cycles. The sending-end and receiving-end voltages are established at 1.05 per unit at 120 degree system separation angle. The 1.05 per unit is the typical upper end of the operating voltage, which is also consistent with the maximum power

## PRC-026-1 – Application Guidelines

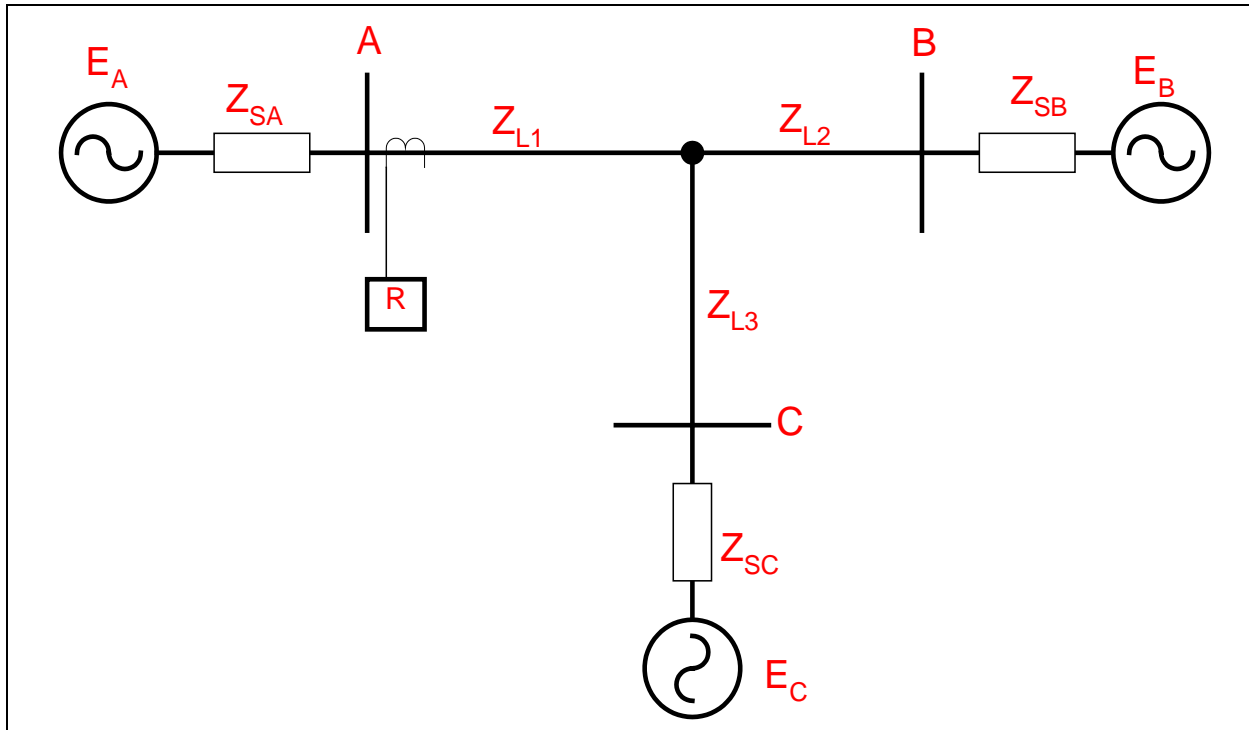
transfer calculation using actual system source impedances in the PRC-023 NERC Reliability Standard. The formulas used to calculate the current are in Table 14 below.

<b>Table 14: Example Calculation (Overcurrent)</b>			
<p>This example is for a 230 kV line terminal with a directional instantaneous phase overcurrent element set to 50 amps secondary times a CT ratio of 160:1 that equals 8,000 amps, primary. The following calculation is where <math>V_S</math> equals the base line-to-ground sending-end generator source voltage times 1.05 at an angle of 120 degrees, <math>V_R</math> equals the base line-to-ground receiving-end generator internal voltage times 1.05 at an angle of 0 degrees, and <math>Z_{sys}</math> equals the sum of the sending-end source, line, and receiving-end source impedances in ohms.</p> <p>Here, the instantaneous phase setting of 8,000 amps is greater than the calculated system current of 5,716 amps; therefore, it meets PRC-026-1 – Attachment B, Criterion B.</p>			
Eq. (102)	$V_S = \frac{V_{LL} \angle 120^\circ}{\sqrt{3}} \times 1.05$		
	$V_S = \frac{230,000 \angle 120^\circ V}{\sqrt{3}} \times 1.05$		
	$V_S = 139,430 \angle 120^\circ V$		
Receiving-end generator terminal voltage.			
Eq. (103)	$V_R = \frac{V_{LL} \angle 0^\circ}{\sqrt{3}} \times 1.05$		
	$V_R = \frac{230,000 \angle 0^\circ V}{\sqrt{3}} \times 1.05$		
	$V_R = 139,430 \angle 0^\circ V$		
<p>The total impedance of the system (<math>Z_{sys}</math>) equals the sum of the sending-end source impedance (<math>Z_S</math>), the impedance of the line (<math>Z_L</math>), and receiving-end impedance (<math>Z_R</math>) in ohms.</p>			
Given:	$Z_S = 3 + j26 \Omega$	$Z_L = 1.3 + j8.7 \Omega$	$Z_R = 0.3 + j7.3 \Omega$
Eq. (104)	$Z_{sys} = Z_S + Z_L + Z_R$		
	$Z_{sys} = (3 + j26) \Omega + (1.3 + j8.7) \Omega + (0.3 + j7.3) \Omega$		
	$Z_{sys} = 4.6 + j42 \Omega$		
Total system current.			
Eq. (105)	$I_{sys} = \frac{(V_S - V_R)}{Z_{sys}}$		
	$I_{sys} = \frac{(139,430 \angle 120^\circ V - 139,430 \angle 0^\circ V)}{(4.6 + j42) \Omega}$		
	$I_{sys} = 5,715.82 \angle 66.25^\circ A$		

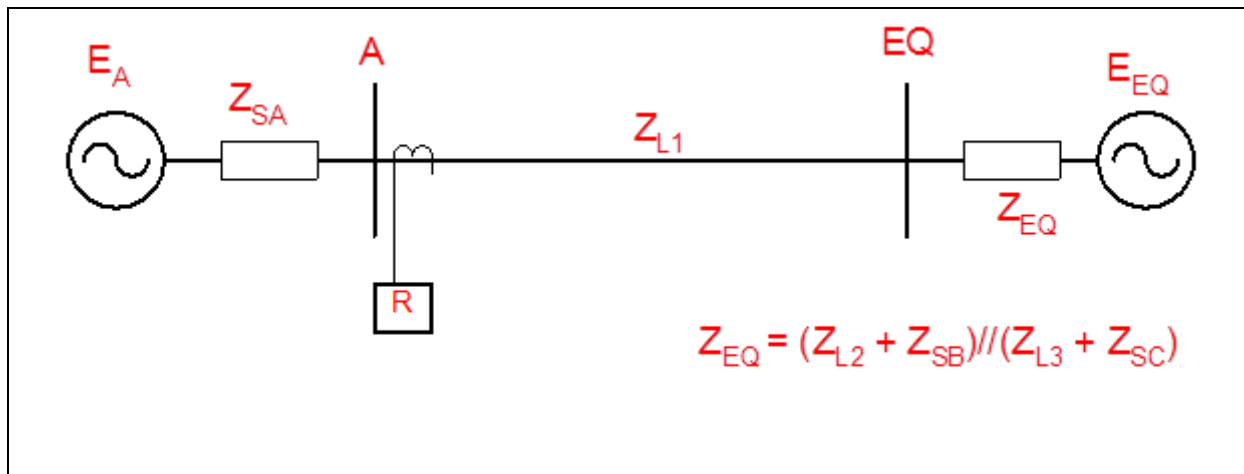
### Application Specific to Three-Terminal Lines

If a three-terminal line is identified as an Element that is susceptible to a power swing based on Requirement R1, the load-responsive protective relays at each end of the three-terminal line must be evaluated.

As shown in Figure 15j, the source impedances at each end of the line can be obtained from the similar short circuit calculation as for the two-terminal line (assuming the parallel transfer impedances are ignored).



**Figure 15j:** Three-terminal line. To evaluate the load-responsive protective relays on the three-terminal line at Terminal A, the circuit in Figure 15j is first reduced to the equivalent circuit shown in Figure 15k. The evaluation process for the load-responsive protective relays on the line at Terminal A will now be the same as that of the two-terminal line.



**Figure 15k:** Three-terminal line reduced to a two-terminal line.

### Application to Generation Elements

As with transmission BES Elements, the determination of the apparent impedance seen at an Element located at, or near, a generation Facility is complex for power swings due to various interdependent quantities. These variances in quantities are caused by changes in machine internal voltage, speed governor action, voltage regulator action, the reaction of other local generators, and the reaction of other interconnected transmission BES Elements as the event progresses through the time domain. Though transient stability simulations may be used to determine the apparent impedance for verifying load-responsive relay settings,<sup>20,21</sup> Requirement R2, PRC-026-1 – Attachment B, Criteria A and B provides a simplified method for evaluating the load-responsive protective relay’s susceptibility to tripping in response to a stable power swing without requiring stability simulations.

In general, the electrical center will be in the transmission system for cases where the generator is connected through a weak transmission system (high external impedance). In other cases where the generator is connected through a strong transmission system, the electrical center could be inside the unit connected zone.<sup>22</sup> In either case, load-responsive protective relays connected at the generator terminals or at the high-voltage side of the generator step-up (GSU) transformer may be challenged by power swings. Relays that may be challenged by power swings will be determined by the Planning Coordinator in Requirement R1 or by the Generator Owner after becoming aware of a generator, transformer, or transmission line BES Element that tripped<sup>23</sup> in response to a stable or unstable power swing due to the operation of its protective relay(s) in Requirement R2.

<sup>20</sup> Donald Reimert, *Protective Relaying for Power Generation Systems*, Boca Raton, FL, CRC Press, 2006.

<sup>21</sup> Prabha Kundur, *Power System Stability and Control*, EPRI, McGraw Hill, Inc., 1994.

<sup>22</sup> Ibid, Kundur.

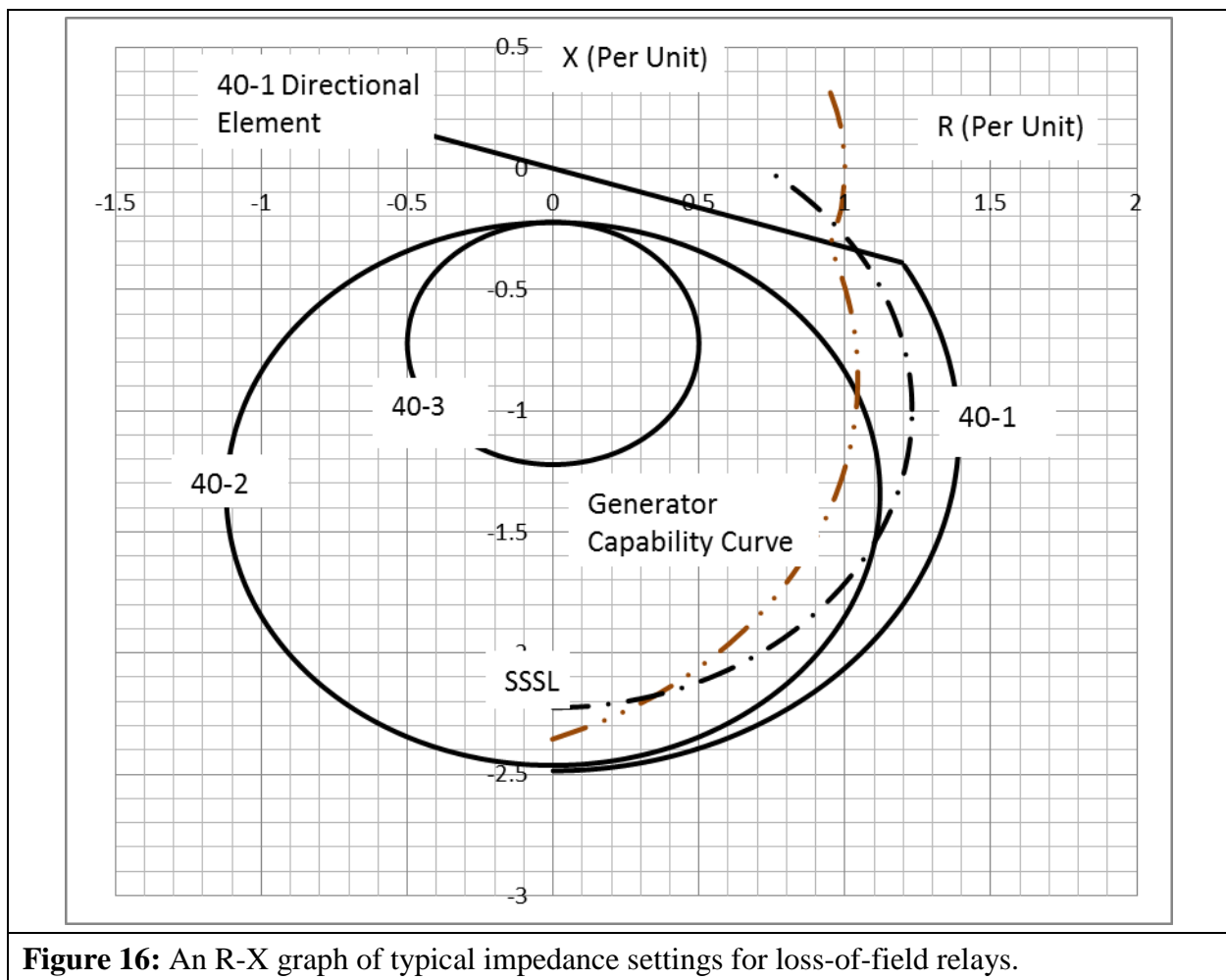
<sup>23</sup> See Guidelines and Technical Basis section, “Becoming Aware of an Element That Tripped in Response to a Power Swing,”

## PRC-026-1 – Application Guidelines

Voltage controlled time-overcurrent and voltage-restrained time-overcurrent relays are excluded from this standard. When these relays are set based on equipment permissible overload capability, their operating times are much greater than 15 cycles for the current levels observed during a power swing.

Instantaneous overcurrent, time-overcurrent, and definite-time overcurrent relays with a time delay of less than 15 cycles for the current levels observed during a power swing are applicable and are required to be evaluated for identified Elements.

The generator loss-of-field protective function is provided by impedance relay(s) connected at the generator terminals. The settings are applied to protect the generator from a partial or complete loss of excitation under all generator loading conditions and, at the same time, be immune to tripping on stable power swings. It is more likely that the loss-of-field relay would operate during a power swing when the automatic voltage regulator (AVR) is in manual mode rather than when in automatic mode.<sup>24</sup> Figure 16 illustrates the loss-of-field relay in the R-X plot, which typically includes up to three zones of protection.



<sup>24</sup> John Burdy, *Loss-of-excitation Protection for Synchronous Generators GER-3183*, General Electric Company.

Loss-of-field characteristic 40-1 has a wider impedance characteristic (positive offset) than characteristic 40-2 or characteristic 40-3 and provides additional generator protection for a partial loss of field or a loss of field under low load (less than 10% of rated). The tripping logic of this protection scheme is established by a directional contact, a voltage setpoint, and a time delay. The voltage and time delay add security to the relay operation for stable power swings. Characteristic 40-3 is less sensitive to power swings than characteristic 40-2 and is set outside the generator capability curve in the leading direction. Regardless of the relay impedance setting, PRC-019<sup>25</sup> requires that the “in-service limiters operate before Protection Systems to avoid unnecessary trip” and “in-service Protection System devices are set to isolate or de-energize equipment in order to limit the extent of damage when operating conditions exceed equipment capabilities or stability limits.” Time delays for tripping associated with loss-of-field relays<sup>26,27</sup> have a range from 15 cycles for characteristic 40-2 to 60 cycles for characteristic 40-1 to minimize tripping during stable power swings. In PRC-026-1, 15 cycles establishes a threshold for applicability; however, it is the responsibility of the Generator Owner to establish settings that provide security against stable power swings and, at the same time, dependable protection for the generator.

The simple two-machine system circuit (method also used in the Application to Transmission Elements section) is used to analyze the effect of a power swing at a generator facility for load-responsive relays. In this section, the calculation method is used for calculating the impedance seen by the relay connected at a point in the circuit.<sup>28</sup> The electrical quantities used to determine the apparent impedance plot using this method are generator saturated transient reactance ( $X'_d$ ), GSU transformer impedance ( $X_{GSU}$ ), transmission line impedance ( $Z_L$ ), and the system equivalent ( $Z_e$ ) at the point of interconnection. All impedance values are known to the Generator Owner except for the system equivalent. The system equivalent is obtainable from the Transmission Owner. The sending-end and receiving-end source voltages are varied from 0.0 to 1.0 per unit to form the lens shape portion of the unstable power swing region. The voltage range of 0.7 to 1.0 results in a ratio range from 0.7 to 1.43. This ratio range is used to form the lower and upper loss-of-synchronism circle shapes of the unstable power swing region. A system separation angle of 120 degrees is used in accordance with PRC-026-1 – Attachment B criteria for each load-responsive protective relay evaluation.

Table 15 below is an example calculation of the apparent impedance locus method based on Figures 17 and 18.<sup>29</sup> In this example, the generator is connected to the 345 kV transmission system through the GSU transformer and has the listed ratings. Note that the load-responsive protective relays in this example may have ownership with the Generator Owner or the Transmission Owner.

---

<sup>25</sup> Coordination of Generating Unit or Plant Capabilities, Voltage Regulating Controls, and Protection

<sup>26</sup> Ibid, Burdy.

<sup>27</sup> *Applied Protective Relaying*, Westinghouse Electric Corporation, 1979.

<sup>28</sup> Edward Wilson Kimbark, *Power System Stability, Volume II: Power Circuit Breakers and Protective Relays*, Published by John Wiley and Sons, 1950.

<sup>29</sup> Ibid, Kimbark.

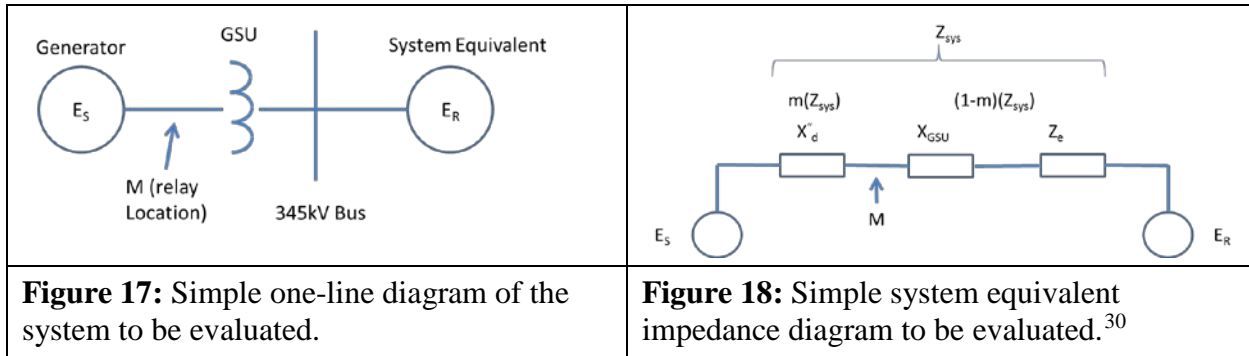


Table15: Example Data (Generator)	
Input Descriptions	Input Values
Synchronous Generator nameplate (MVA)	940 MVA
Saturated transient reactance (940 MVA base)	$X'_d = 0.3845$ per unit
Generator rated voltage (Line-to-Line)	20 kV
Generator step-up (GSU) transformer rating	880 MVA
GSU transformer reactance (880 MVA base)	$X_{GSU} = 16.05\%$
System Equivalent (100 MVA base)	$Z_e = 0.00723 \angle 90^\circ$ per unit
Generator Owner Load-Responsive Protective Relays	
40-1	Positive Offset Impedance
	Offset = 0.294 per unit
	Diameter = 0.294 per unit
40-2	Negative Offset Impedance
	Offset = 0.22 per unit
	Diameter = 2.24 per unit
40-3	Negative Offset Impedance
	Offset = 0.22 per unit
	Diameter = 1.00 per unit
21-1	Diameter = 0.643 per unit
	MTA = 85°

<sup>30</sup> Ibid, Kimbark.



Table15: Example Data (Generator)	
50	I (pickup) = 5.0 per unit
Transmission Owned Load-Responsive Protective Relays	
21-2	Diameter = 0.55 per unit
	MTA = 85°

Calculations shown for a 120 degree angle and  $E_S/E_R = 1$ . The equation for calculating  $Z_R$  is:<sup>31</sup>

$$\text{Eq. (106)} \quad Z_R = \left( \frac{(1 - m)(E_S \angle \delta) + (m)(E_R)}{E_S \angle \delta - E_R} \right) \times Z_{sys}$$

Where m is the relay location as a function of the total impedance (real number less than 1)

$E_S$  and  $E_R$  is the sending-end and receiving-end voltages

$Z_{sys}$  is the total system impedance

$Z_R$  is the complex impedance at the relay location and plotted on an R-X diagram

All of the above are constants (940 MVA base) while the angle  $\delta$  is varied. Table 16 below contains calculations for a generator using the data listed in Table 15.

Table16: Example Calculations (Generator)			
The following calculations are on a 940 MVA base.			
Given:	$X'_d = j0.3845 pu$	$X_{GSU} = j0.17144 pu$	$Z_e = j0.06796 pu$
Eq. (107)	$Z_{sys} = X'_d + X_{GSU} + Z_e$		
	$Z_{sys} = j0.3845 pu + j0.17144 pu + j0.06796 pu$		
	$Z_{sys} = 0.6239 \angle 90^\circ pu$		
Eq. (108)	$m = \frac{X'_d}{Z_{sys}} = \frac{0.3845}{0.6239} = 0.6163$		
Eq. (109)	$Z_R = \left( \frac{(1 - m)(E_S \angle \delta) + (m)(E_R)}{E_S \angle \delta - E_R} \right) \times Z_{sys}$		
	$Z_R = \left( \frac{(1 - 0.6163) \times (1 \angle 120^\circ) + (0.6163)(1 \angle 0^\circ)}{1 \angle 120^\circ - 1 \angle 0^\circ} \right) \times (0.6239 \angle 90^\circ) pu$		

<sup>31</sup> Ibid, Kimbark.

Table16: Example Calculations (Generator)	
	$Z_R = \left( \frac{0.4244 + j0.3323}{-1.5 + j 0.866} \right) \times (0.6239 \angle 90^\circ) pu$
	$Z_R = (0.3116 \angle -111.95^\circ) \times (0.6239 \angle 90^\circ) pu$
	$Z_R = 0.194 \angle -21.95^\circ pu$
	$Z_R = -0.18 - j0.073 pu$

Table 17 lists the swing impedance values at other angles and at  $E_S/E_R = 1, 1.43,$  and  $0.7$ . The impedance values are plotted on an R-X graph with the center being at the generator terminals for use in evaluating impedance relay settings.

Table 17: Sample Calculations for a Swing Impedance Chart for Varying Voltages at the Sending-End and Receiving-End.						
Angle ( $\delta$ ) (Degrees)	$E_S/E_R=1$		$E_S/E_R=1.43$		$E_S/E_R=0.7$	
	$Z_R$		$Z_R$		$Z_R$	
	Magnitude (pu)	Angle (Degrees)	Magnitude (pu)	Angle (Degrees)	Magnitude (pu)	Angle (Degrees)
90	0.320	-13.1	0.296	6.3	0.344	-31.5
120	0.194	-21.9	0.173	-0.4	0.227	-40.1
150	0.111	-41.0	0.082	-10.3	0.154	-58.4
210	0.111	-25.9	0.082	190.3	0.154	238.4
240	0.194	201.9	0.173	180.4	0.225	220.1
270	0.320	193.1	0.296	173.7	0.344	211.5

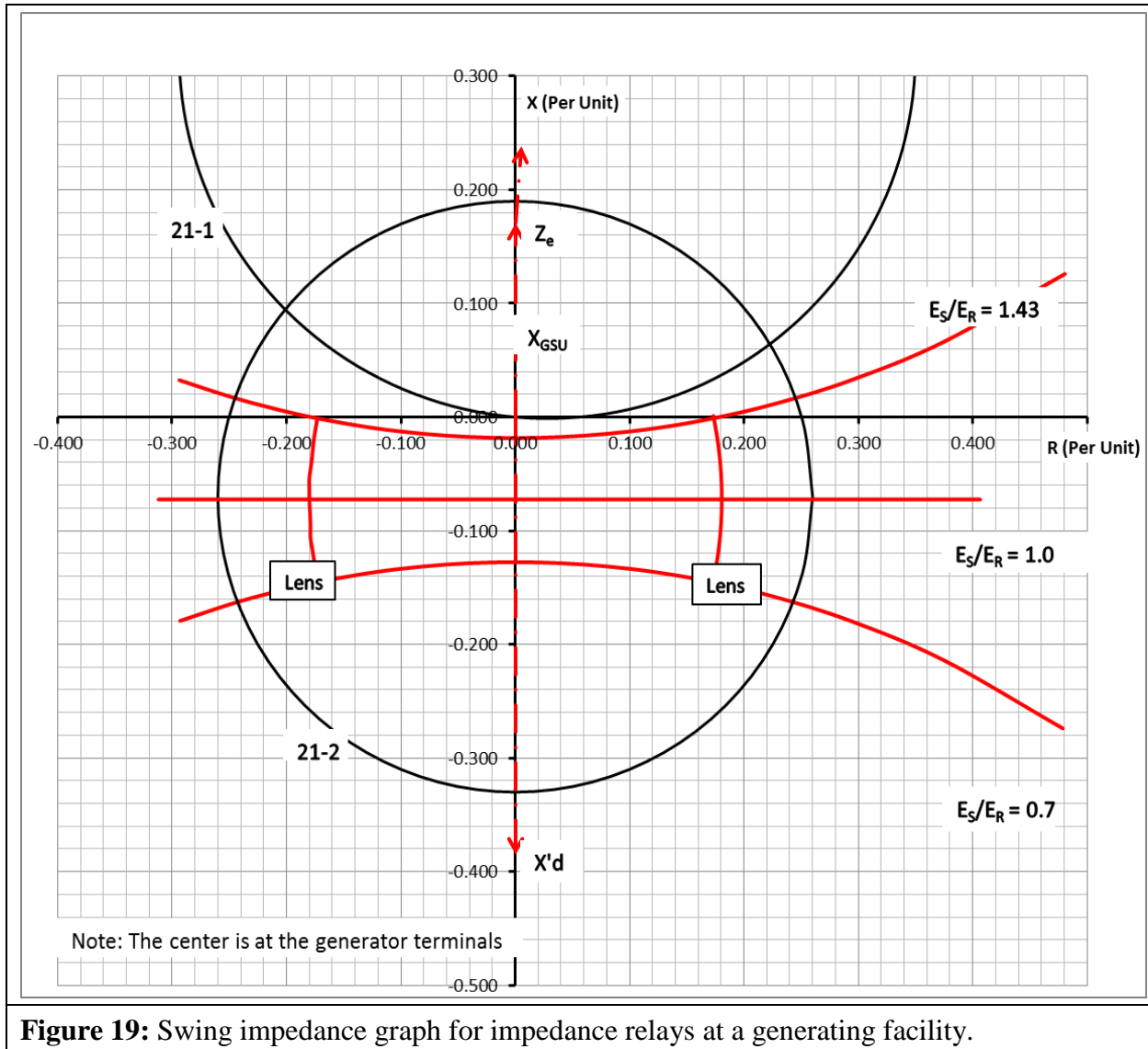
## Requirement R2 Generator Examples

### *Distance Relay Application*

Based on PRC-026-1 – Attachment B, Criterion A, the distance relay (21-1) (i.e., owned by the Generation Owner) characteristic is in the region where a stable power swing would not occur as shown in Figure 19. There is no further obligation to the owner in this standard for this load-responsive protective relay.

The distance relay (21-2) (i.e., owned by the Transmission Owner) is connected at the high-voltage side of the GSU transformer and its impedance characteristic is in the region where a stable power swing could occur causing the relay to operate. In this example, if the intentional time delay of this relay is less than 15 cycles, the PRC-026 – Attachment B, Criterion A cannot be met, thus the Transmission Owner is required to create a CAP (Requirement R3). Some of the options include,

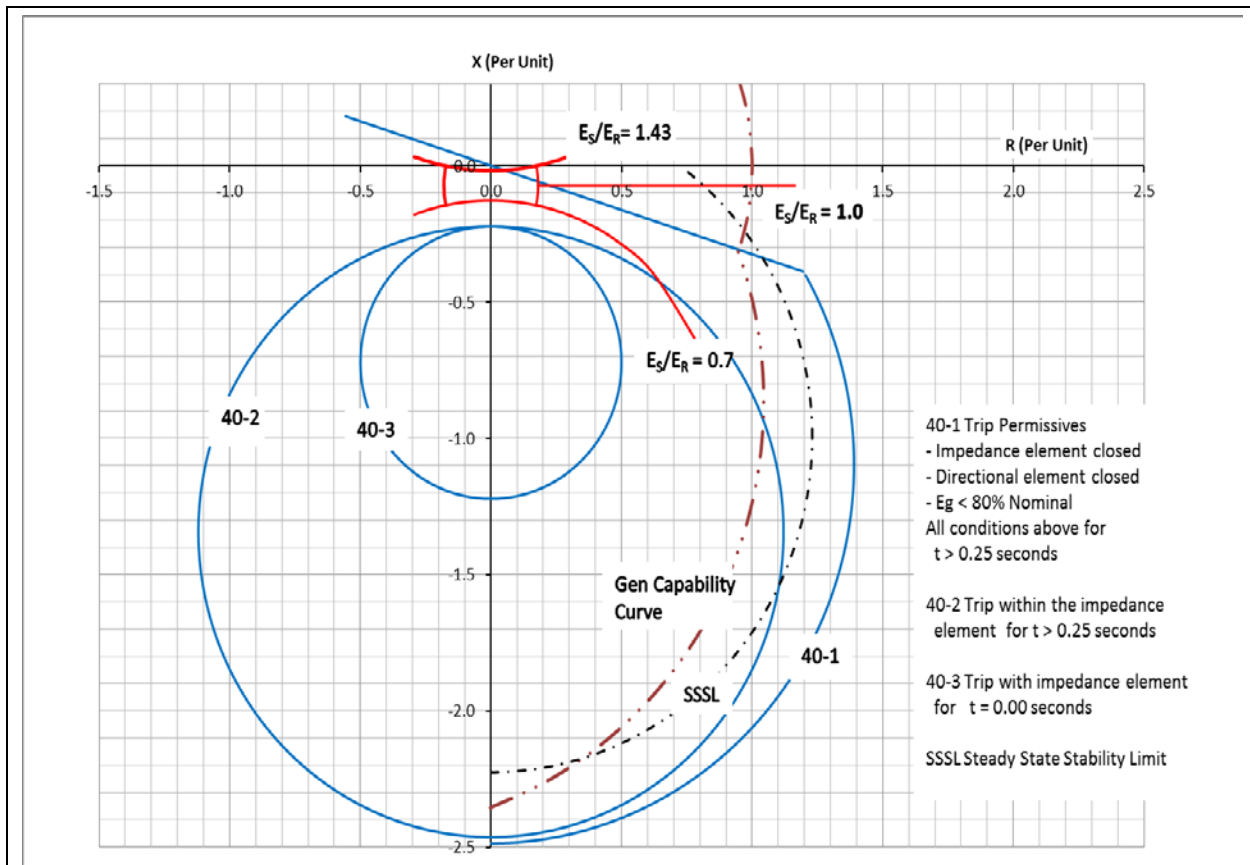
but are not limited to, changing the relay setting (i.e., impedance reach, angle, time delay), modify the scheme (i.e., add PSB), or replace the Protection System. Note that the relay may be excluded from this standard if it has an intentional time delay equal to or greater than 15 cycles.



### Loss-of-Field Relay Application

In Figure 20, the R-X diagram shows the loss-of-field relay (40-1 and 40-2) characteristics are in the region where a stable power swing can cause a relay operation. Protective relay 40-1 would be excluded if it has an intentional time delay equal to or greater than 15 cycles. Similarly, 40-2 would be excluded if its intentional time delay is equal to or greater than 15 cycles. For example, if 40-1 has a time delay of 1 second and 40-2 has a time delay of 0.25 seconds, they are excluded and there is no further obligation on the Generator Owner in this standard for these relays. The

loss-of-field relay characteristic 40-3 is entirely inside the unstable power swing region. In this case, the owner may select high speed tripping on operation of the 40-3 impedance element.



**Figure 20:** Typical R-X graph for loss-of-field relays with a portion of the unstable power swing region defined by PRC-026-1 – Attachment B, Criterion A.

### **Instantaneous Overcurrent Relay**

In similar fashion to the transmission line overcurrent example calculation in Table 14, the instantaneous overcurrent relay minimum setting is established by PRC-026-1 – Attachment B, Criterion B. The solution is found by:

$$\text{Eq. (110)} \quad I_{sys} = \frac{E_S - E_R}{Z_{sys}}$$

As stated in the relay settings in Table 15, the relay is installed on the high-voltage side of the GSU transformer with a pickup of 5.0 per unit. The maximum allowable current is calculated below.

$$I_{sys} = \frac{(1.05 \angle 120^\circ - 1.05 \angle 0^\circ)}{0.6239 \angle 90^\circ} \text{ pu}$$

$$I_{sys} = \frac{1.819 \angle 150^\circ}{0.6239 \angle 90^\circ} pu$$

$$I_{sys} = 2.91 \angle 60^\circ pu$$

The instantaneous phase setting of 5.0 per unit is greater than the calculated system current of 2.91 per unit; therefore, it meets the PRC-026-1 – Attachment B, Criterion B.

### ***Out-of-Step Tripping for Generation Facilities***

Out-of-step protection for the generator generally falls into three different schemes. The first scheme is a distance relay connected at the high-voltage side of the GSU transformer with the directional element looking toward the generator. Because this relay setting may be the same setting used for generator backup protection (see Requirement R2 Generator Examples, Distance Relay Application), it is susceptible to tripping in response to stable power swings and would require modification. Because this scheme is susceptible to tripping in response to stable power swings and any modification to the mho circle will jeopardize the overall protection of the out-of-step protection of the generator, available technical literature does not recommend using this scheme specifically for generator out-of-step protection. The second and third out-of-step Protection System schemes are commonly referred to as single and double blinder schemes. These schemes are installed or enabled for out-of-step protection using a combination of blinders, a mho element, and timers. The combination of these protective relay functions provides out-of-step protection and discrimination logic for stable and unstable power swings. Single blinder schemes use logic that discriminate between stable and unstable power swings by issuing a trip command after the first slip cycle. Double blinder schemes are more complex than the single blinder scheme and, depending on the settings of the inner blinder, a trip for a stable power swing may occur. While the logic discriminates between stable and unstable power swings in either scheme, it is important that the trip initiating blinders be set at an angle greater than the stability limit of 120 degrees to remove the possibility of a trip for a stable power swing. Below is a discussion of the double blinder scheme.

### ***Double Blinder Scheme***

The double blinder scheme is a method for measuring the rate of change of positive sequence impedance for out-of-step swing detection. The scheme compares a timer setting to the actual elapsed time required by the impedance locus to pass between two impedance characteristics. In this case, the two impedance characteristics are simple blinders, each set to a specific resistive reach on the R-X plane. Typically, the two blinders on the left half plane are the mirror images of those on the right half plane. The scheme typically includes a mho characteristic which acts as a starting element, but is not a tripping element.

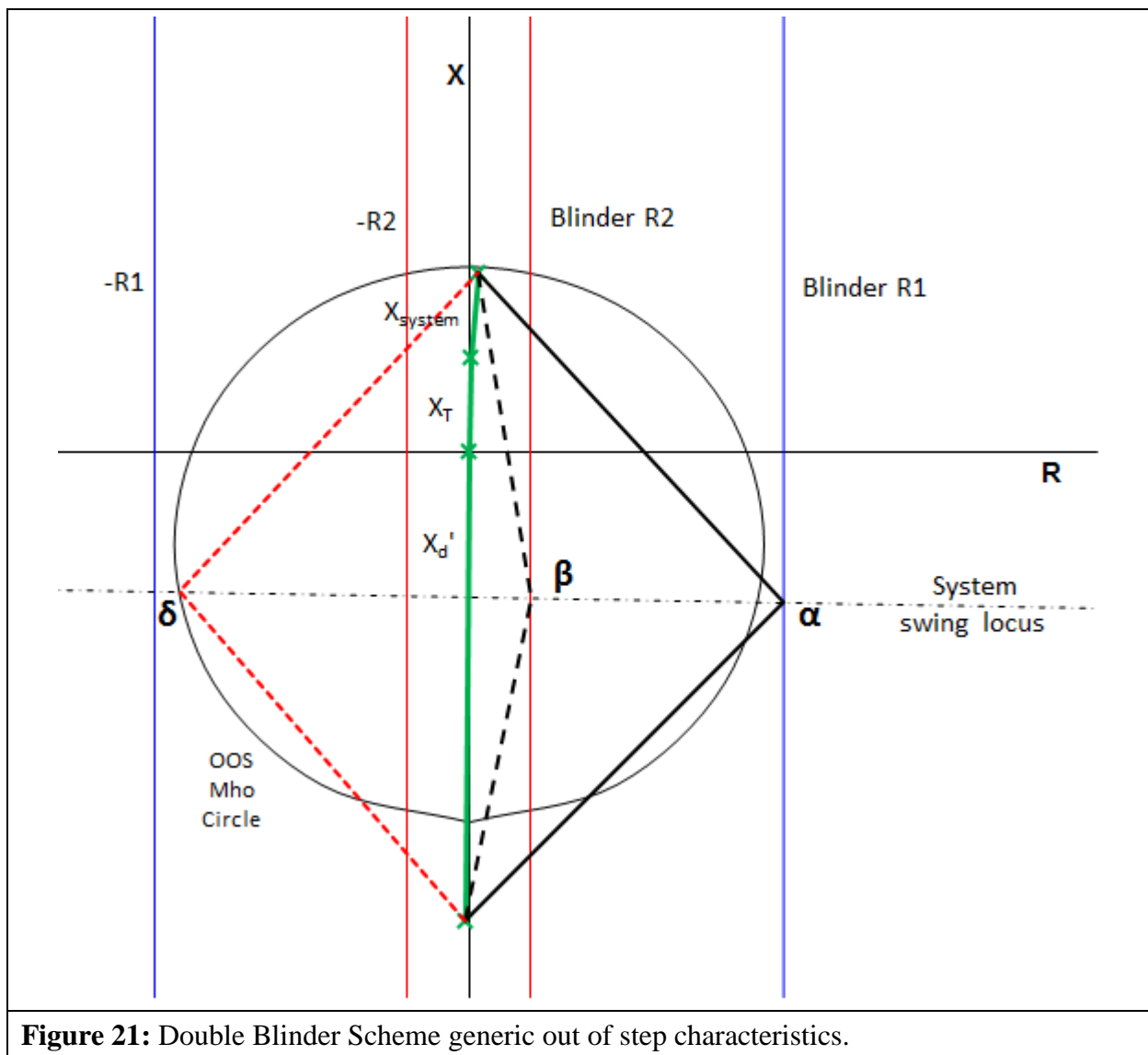
The scheme detects the blinder crossings and time delays as represented on the R-X plane as shown in Figure 21. The system impedance is composed of the generator transient ( $X_d'$ ), GSU transformer ( $X_T$ ), and transmission system ( $X_{system}$ ), impedances.

The scheme logic is initiated when the swing locus crosses the outer Blinder R1 (Figure 21), on the right at separation angle  $\alpha$ . The scheme only commits to take action when a swing crosses the

## PRC-026-1 – Application Guidelines

inner blinder. At this point the scheme logic seals in the out-of-step trip logic at separation angle  $\beta$ . Tripping actually asserts as the impedance locus leaves the scheme characteristic at separation angle  $\delta$ .

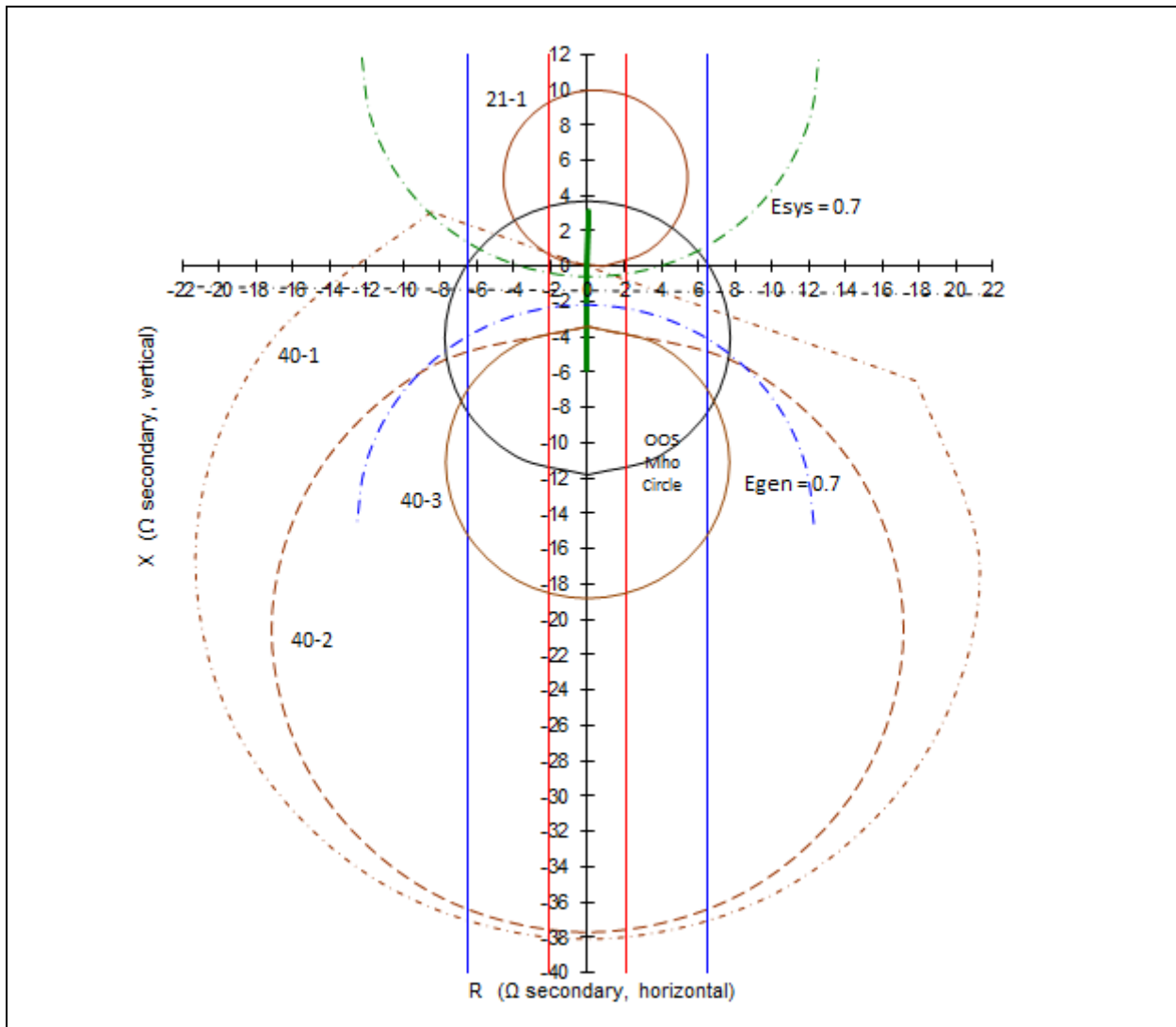
The power swing may leave both inner and outer blinders in either direction, and tripping will assert. Therefore, the inner blinder must be set such that the separation angle  $\beta$  is large enough that the system cannot recover. This angle should be set at 120 degrees or more. Setting the angle greater than 120 degrees satisfies the PRC-026-1 – Attachment B, Criterion A (No. 1, 1<sup>st</sup> bullet) since the tripping function is asserted by the blinder element. Transient stability studies may indicate that a smaller stability limit angle is acceptable under PRC-026-1 – Attachment B, Criterion A (No. 1, 2<sup>nd</sup> bullet). In this respect, the double blinder scheme is similar to the double lens and triple lens schemes and many transmission application out-of-step schemes.



**Figure 21:** Double Blinder Scheme generic out of step characteristics.

## PRC-026-1 – Application Guidelines

Figure 22 illustrates a sample setting of the double blinder scheme for the example 940 MVA generator. The only setting requirement for this relay scheme is the right inner blinder, which must be set greater than the separation angle of 120 degrees (or a lesser angle based on a transient stability study) to ensure that the out-of-step protective function is expected to not trip in response to a stable power swing during non-Fault conditions. Other settings such as the mho characteristic, outer blinders, and timers are set according to transient stability studies and are not a part of this standard.



**Figure 22:** Double Blinder Out-of-Step Scheme with unit impedance data and load-responsive protective relay impedance characteristics for the example 940 MVA generator, scaled in relay secondary ohms.

### Requirement R3

To achieve the stated purpose of this standard, which is to ensure that relays are expected to not trip in response to stable power swings during non-Fault conditions, this Requirement ensures that the applicable entity develops a Corrective Action Plan (CAP) that reduces the risk of relays tripping in response to a stable power swing during non-Fault conditions that may occur on any applicable BES Element.

### Requirement R4

To achieve the stated purpose of this standard, which is to ensure that load-responsive protective relays are expected to not trip in response to stable power swings during non-Fault conditions, the applicable entity is required to implement any CAP developed pursuant to Requirement R3 such that the Protection System will meet PRC-026-1 – Attachment B criteria or can be excluded under the PRC-026-1 – Attachment A criteria (e.g., modifying the Protection System so that relay functions are supervised by power swing blocking or using relay systems that are immune to power swings), while maintaining dependable fault detection and dependable out-of-step tripping (if out-of-step tripping is applied at the terminal of the BES Element). Protection System owners are required in the implementation of a CAP to update it when actions or timetable change, until all actions are complete. Accomplishing this objective is intended to reduce the occurrence of Protection System tripping during a stable power swing, thereby improving reliability and minimizing risk to the BES.

The following are examples of actions taken to complete CAPs for a relay that did not meet PRC-026-1 – Attachment B and could be at-risk of tripping in response to a stable power swing during non-Fault conditions. A Protection System change was determined to be acceptable (without diminishing the ability of the relay to protect for faults within its zone of protection).

**Example R4a:** Actions: Settings were issued on 6/02/2015 to reduce the Zone 2 reach of the impedance relay used in the directional comparison unblocking (DCUB) scheme from 30 ohms to 25 ohms so that the relay characteristic is completely contained within the lens characteristic identified by the criterion. The settings were applied to the relay on 6/25/2015. CAP was completed on 06/25/2015.

**Example R4b:** Actions: Settings were issued on 6/02/2015 to enable out-of-step blocking on the existing microprocessor-based relay to prevent tripping in response to stable power swings. The setting changes were applied to the relay on 6/25/2015. CAP was completed on 06/25/2015.



## PRC-026-1 – Application Guidelines

The following is an example of actions taken to complete a CAP for a relay responding to a stable power swing that required the addition of an electromechanical power swing blocking relay.

**Example R4c:** Actions: A project for the addition of an electromechanical power swing blocking relay to supervise the Zone 2 impedance relay was initiated on 6/5/2015 to prevent tripping in response to stable power swings. The relay installation was completed on 9/25/2015. CAP was completed on 9/25/2015.

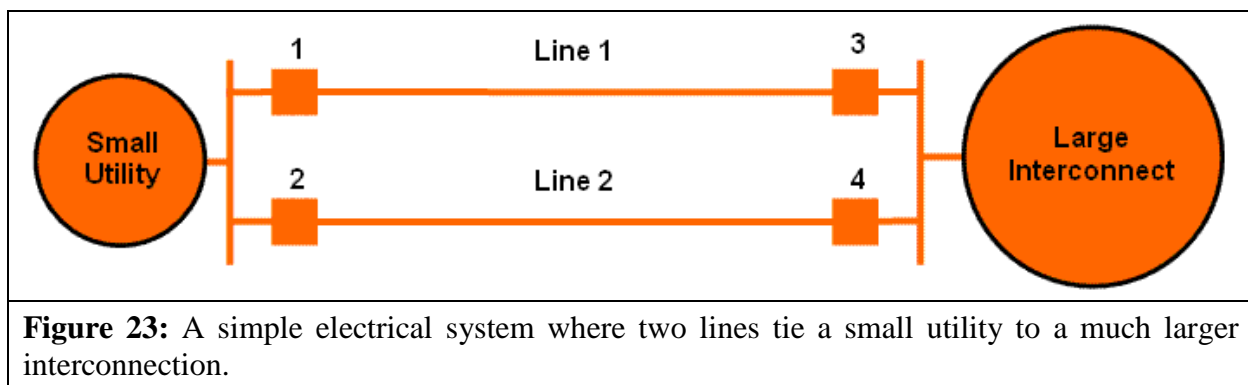
The following is an example of actions taken to complete a CAP with a timetable that required updating for the replacement of the relay.

**Example R4d:** Actions: A project for the replacement of the impedance relays at both terminals of line X with line current differential relays was initiated on 6/5/2015 to prevent tripping in response to stable power swings. The completion of the project was postponed due to line outage rescheduling from 11/15/2015 to 3/15/2016. Following the timetable change, the impedance relay replacement was completed on 3/18/2016. CAP was completed on 3/18/2016.

The CAP is complete when all the documented actions to remedy the specific problem (i.e., unnecessary tripping during stable power swings) are completed.

## Justification for Including Unstable Power Swings in the Requirements

Protection Systems that are applicable to the Standard and must be secure for a stable power swing condition (i.e., meets PRC-026-1 – Attachment B criteria) are identified based on Elements that are susceptible to both stable and unstable power swings. This section provides an example of why Elements that trip in response to unstable power swings (in addition to stable power swings) are identified and that their load-responsive protective relays need to be evaluated under PRC-026-1 – Attachment B criteria.

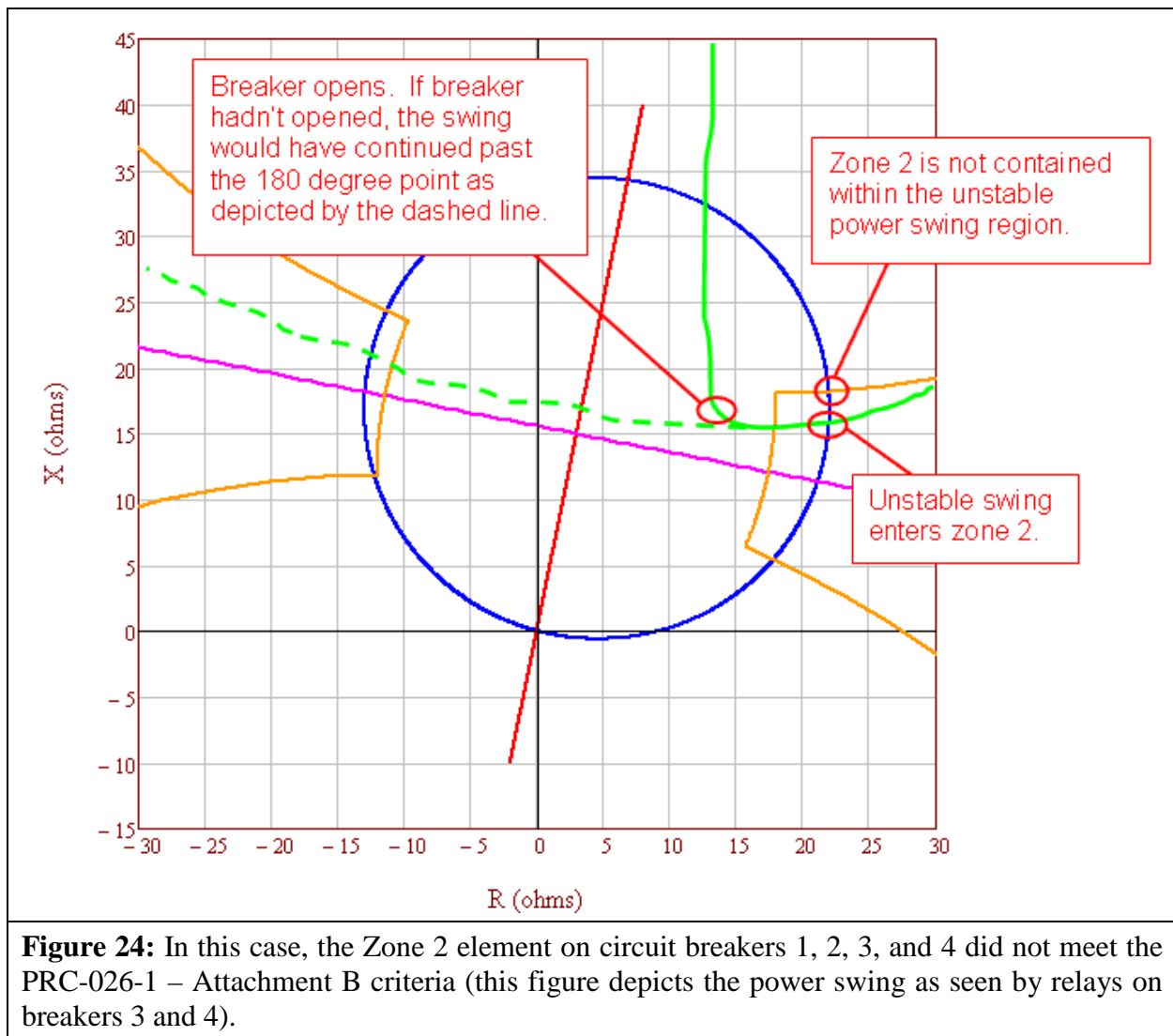


**Figure 23:** A simple electrical system where two lines tie a small utility to a much larger interconnection.

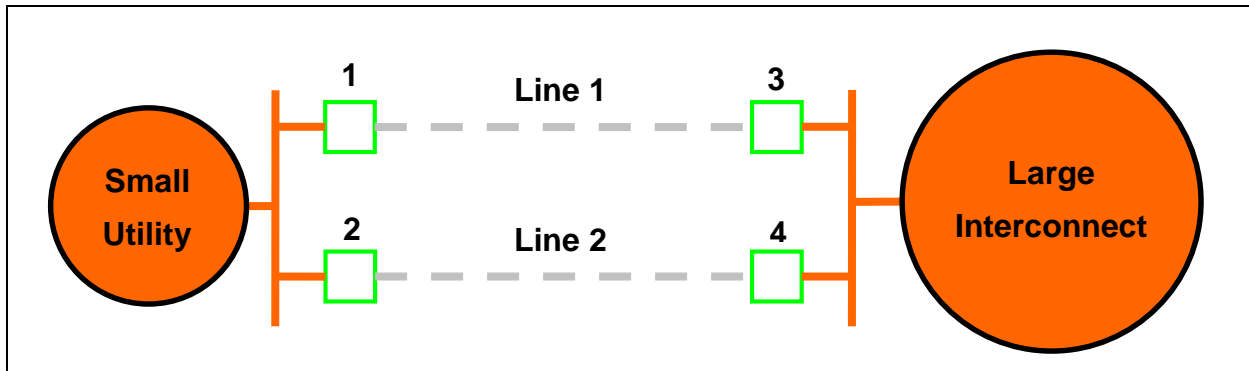
In Figure 23 the relays at circuit breakers 1, 2, 3, and 4 are equipped with a typical overreaching Zone 2 pilot system, using a Directional Comparison Blocking (DCB) scheme. Internal faults (or power swings) will result in instantaneous tripping of the Zone 2 relays if the measured fault or power swing impedance falls within the zone 2 operating characteristic. These lines will trip on

## PRC-026-1 – Application Guidelines

pilot Zone 2 for out-of-step conditions if the power swing impedance characteristic enters into Zone 2. All breakers are rated for out-of-phase switching.

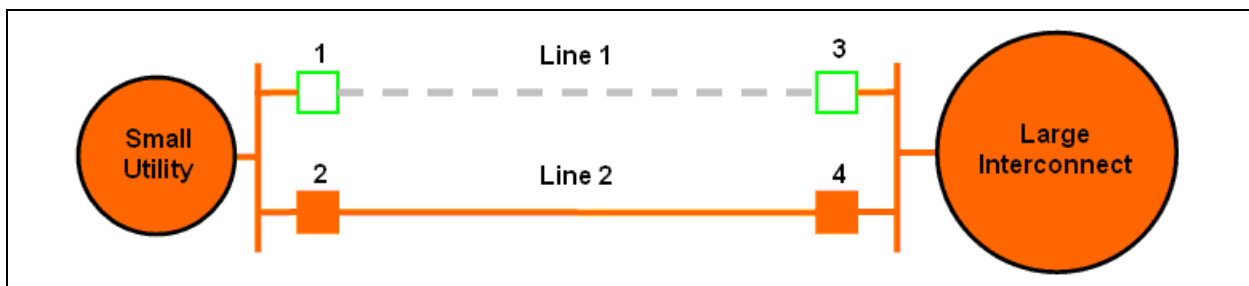


In Figure 24, a large disturbance occurs within the small utility and its system goes out-of-step with the large interconnect. The small utility is importing power at the time of the disturbance. The actual power swing, as shown by the solid green line, enters the Zone 2 relay characteristic on the terminals of Lines 1, 2, 3, and 4 causing both lines to trip as shown in Figure 25.



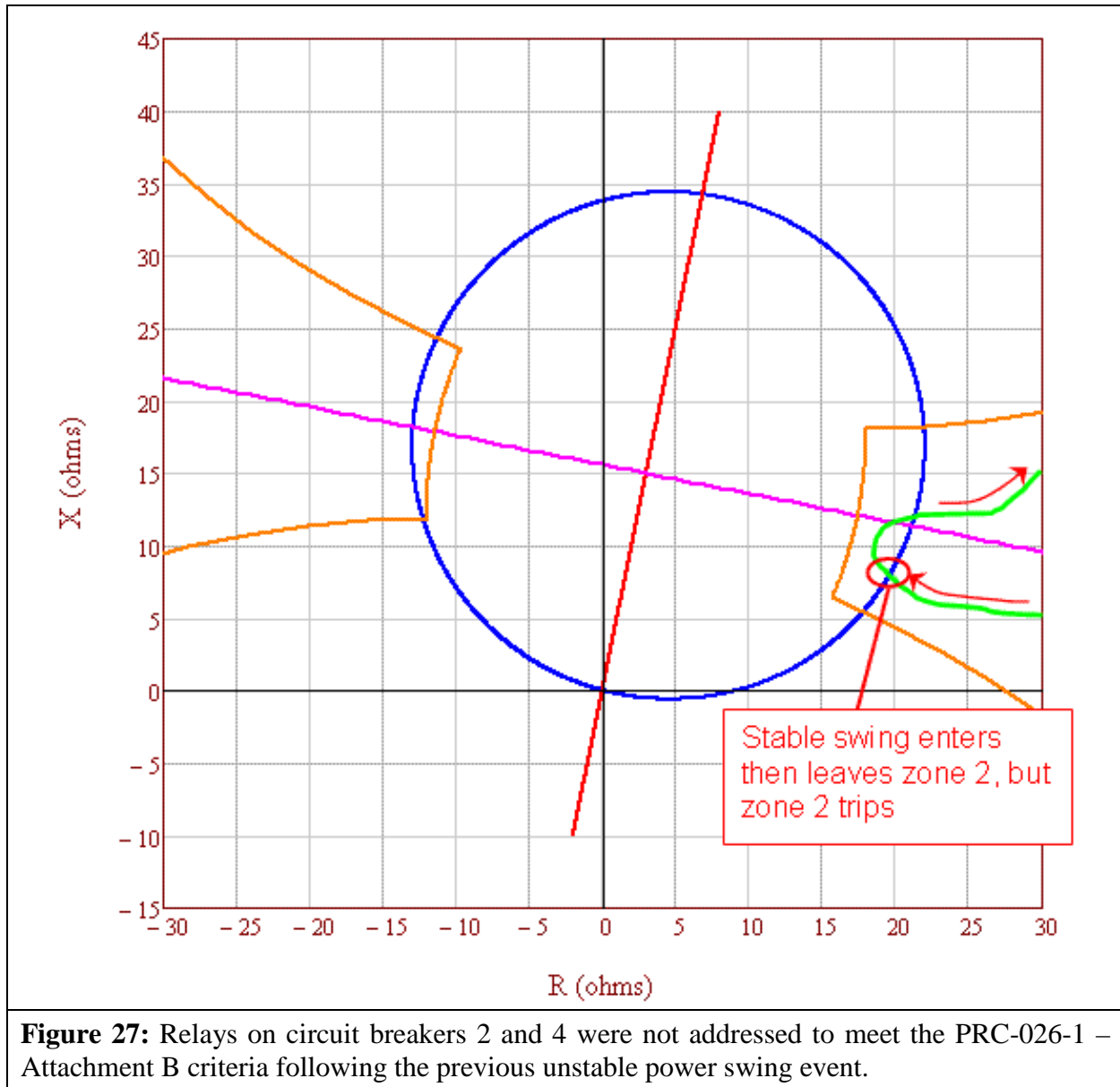
**Figure 25:** Islanding of the small utility due to Lines 1 and 2 tripping in response to an unstable power swing.

In Figure 25, the relays at circuit breakers 1, 2, 3, and 4 have correctly tripped due to the unstable power swing (shown by the dashed green line in Figure 24), de-energizing Lines 1 and 2, and creating an island between the small utility and the big interconnect. The small utility shed 500 MW of load on underfrequency and maintained a load to generation balance.

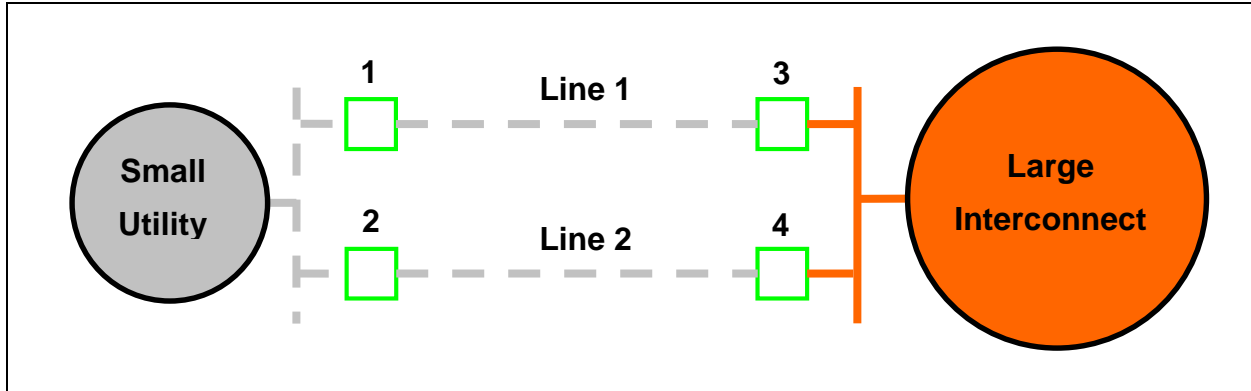


**Figure 26:** Line 1 is out-of-service for maintenance, Line 2 is loaded beyond its normal rating (but within its emergency rating).

Subsequent to the correct tripping of Lines 1 and 2 for the unstable power swing in Figure 25, another system disturbance occurs while the system is operating with Line 1 out-of-service for maintenance. The disturbance causes a stable power swing on Line 2, which challenges the relays at circuit breakers 2 and 4 as shown in Figure 27.



If the relays on circuit breakers 2 and 4 were not addressed under the Requirements for the previous unstable power swing condition, the relays would trip in response to the stable power swing, which would result in unnecessary system separation, load shedding, and possibly cascading or blackout.



**Figure 28:** Possible blackout of the small utility.

If the relays that tripped in response to the previous unstable power swing condition in Figure 24 were addressed under the Requirements to meet PRC-026-1 - Attachment B criteria, the unnecessary tripping of the relays for the stable power swing shown in Figure 28 would have been averted, and the possible blackout of the small utility would have been avoided.

## Standard Development Timeline

*This section is maintained by the drafting team during the development of the standard and will be removed when the standard becomes effective.*

### Development Steps Completed

1. Standards Authorization Request (SAR) posted for comment from August 19, 2010, through September 19, 2010.
2. Standards Committee (SC) authorized moving the SAR forward into standard development on August 12, 2010.
3. SC authorized initial posting of Draft 1 on April 24, 2014.
4. Draft 1 of PRC-026-1 was posted for a 45-day formal comment period from April 25 – June 9, 2014, with a concurrent/parallel initial ballot in the last ten days of the comment period from May 30 – June 9, 2014.
5. Draft 2 of PRC-026-1 was posted for an additional 45-day formal comment period from August 22 – October 6, 2014 with a concurrent/parallel additional ballot in the last ten days of the comment period from September 26 – October 6, 2014.
6. SC authorized a waiver of the Standards Process Manual on October 22, 2014 to reduce the Draft 3 additional formal comment period of PRC-026-1 from 45 days to 21 days with a concurrent/additional ballot period in the last ten days of the comment period.
7. Draft 3 of PRC-026-1 was posted for an additional 21-day formal comment period from November 4 – November 24, 2014 with a concurrent/parallel additional ballot in the last ten days of the comment period from November 14 – November 24, 2014

### Description of Current Draft

The Protection System Response to Power Swings Standard Drafting Team (PSRPS SDT) is posting Draft ~~34~~ of PRC-026-1 – Relay Performance During Stable Power Swings for a ~~21~~10-day ~~additional comment period and concurrent/parallel additional~~ final ballot ~~in the last ten days of the comment period.~~

Anticipated Actions	Anticipated Date
45-day Formal Comment Period with Concurrent/Parallel Initial 10-day Ballot	April 2014
45-day Formal Comment Period with Concurrent/Parallel Additional 10-day Ballot	August 2014

Anticipated Actions	Anticipated Date
21-day Formal Comment Period with Concurrent/Parallel Additional 10-day Ballot (Standards Committee authorized a waiver of the Standards Process Manual, October 22, 2014)	<del>October</del> <u>November</u> 2014
Final Ballot	December 2014
NERC Board of Trustees Adoption	December 2014

**Version History**

Version	Date	Action	Change Tracking
1.0	TBD	Effective Date	New

### Definitions of Terms Used in Standard

*This section includes all newly defined or revised terms used in the proposed standard. Terms already defined in the Glossary of Terms Used in Reliability Standards (Glossary) are not repeated here. New or revised definitions listed below become approved when the proposed standard is approved. When the standard becomes effective, these defined terms will be removed from the individual standard and added to the Glossary.*

**Term:** None.



*When this standard has received ballot approval, the rationale boxes will be moved to the Application Guidelines Section of the standard.*

## A. Introduction

1. **Title:** Relay Performance During Stable Power Swings
2. **Number:** PRC-026-1
3. **Purpose:** To ensure that load-responsive protective relays are expected to not trip in response to stable power swings during non-Fault conditions.
4. **Applicability:**
  - 4.1. **Functional Entities:**
    - 4.1.1 Generator Owner that applies load-responsive protective relays as described in PRC-026-1 – Attachment A at the terminals of the Elements listed in Section 4.2, Facilities.
    - 4.1.2 Planning Coordinator.
    - 4.1.3 Transmission Owner that applies load-responsive protective relays as described in PRC-026-1 – Attachment A at the terminals of the Elements listed in Section 4.2, Facilities.
  - 4.2. **Facilities:** The following Elements that are part of the Bulk Electric System (BES):
    - 4.2.1 Generators.
    - 4.2.2 Transformers.
    - 4.2.3 Transmission lines.

## 5. Background:

This is the third phase of a three-phased standard development project that focused on developing this new Reliability Standard to address protective relay operations due to stable power swings. The March 18, 2010, Federal Energy Regulatory Commission (FERC) Order No. 733, approved Reliability Standard PRC-023-1 – Transmission Relay Loadability. In ~~this~~that Order, FERC directed NERC to address three areas of relay loadability that include modifications to the approved PRC-023-1, development of a new Reliability Standard to address generator protective relay loadability, and a new Reliability Standard to address the operation of protective relays due to stable power swings. This project's SAR addresses these directives with a three-phased approach to standard development.

Phase 1 focused on making the specific modifications from FERC Order No. 733 to PRC-023-1 ~~and was completed in the approved~~. Reliability Standard PRC-023-2, which incorporated these modifications, became mandatory on July 1, 2012.

Phase 2 focused on developing a new Reliability Standard, PRC-025-1 – Generator Relay Loadability, to address generator protective relay loadability. PRC-025-1 became

mandatory on October 1, 2014, along with PRC-023-3, which was modified to harmonize PRC-023-2 with PRC-025-1.

Phase 3 ~~of the project establishes Requirements aimed at~~ focuses on preventing protective relays from tripping unnecessarily due to stable power swings by requiring ~~the~~ identification of Elements on which a stable or unstable power swing may affect Protection System operation, ~~and to develop Requirements to assess~~ assessment of the security of load-responsive protective relays to tripping in response to only a stable power swing. ~~Last, to require entities to implement, and implementation of~~ Corrective Action Plans (CAP), where necessary, ~~to improve.~~ Phase 3 improves security of load-responsive protective relays for stable power swings so they are expected to not trip in response to stable power swings during non-Fault conditions; while maintaining dependable fault detection and dependable out-of-step tripping.

## 6. Effective Dates:

### Requirement R1

First day of the first full calendar year that is 12 months after the date that the standard is approved by an applicable governmental authority or as otherwise provided for in a jurisdiction where approval by an applicable governmental authority is required for a standard to go into effect. Where approval by an applicable governmental authority is not required, the standard shall become effective on the first day of the first full calendar year that is 12 months after the date the standard is adopted by the NERC Board of Trustees or as otherwise provided for in that jurisdiction.

### Requirements R2, R3, and R4

First day of the first full calendar year that is 36 months after the date that the standard is approved by an applicable governmental authority or as otherwise provided for in a jurisdiction where approval by an applicable governmental authority is required for a standard to go into effect. Where approval by an applicable governmental authority is not required, the standard shall become effective on the first day of the first full calendar year that is 36 months after the date the standard is adopted by the NERC Board of Trustees or as otherwise provided for in that jurisdiction.

## B. Requirements and Measures

**R1.** Each Planning Coordinator shall, at least once each calendar year, provide notification of each generator, transformer, and transmission line BES Element in its area that ~~meet~~meets one or more of the following criteria, if any, to the respective Generator Owner and Transmission Owner: [*Violation Risk Factor: Medium*] [*Time Horizon: Long-term Planning*]

Criteria:

1. Generator(s) where an angular stability constraint exists that is addressed by a System Operating Limit (SOL) or a Remedial Action Scheme (RAS) and those Elements terminating at the Transmission station associated with the generator(s).
2. An Element that is monitored as part of ~~an~~an SOL identified by the Planning Coordinator's methodology<sup>1</sup> based on an angular stability constraint.
3. An Element that forms the boundary of an island in the most recent underfrequency load shedding (UFLS) design assessment based on application of the Planning Coordinator's criteria for identifying islands, ~~where~~whereonly if the island is formed by tripping the Element due to angular instability.
4. An Element identified in the most recent annual Planning Assessment where relay tripping occurs due to a stable or unstable<sup>2</sup> power swing during a simulated disturbance.

**M1.** Each Planning Coordinator shall have dated evidence that demonstrates notification of the generator, transformer, and transmission line BES Element(s) that meet one or more of the criteria in Requirement R1, if any, to the respective Generator Owner and Transmission Owner. Evidence may include, but is not limited to, the following documentation: emails, facsimiles, records, reports, transmittals, lists, or spreadsheets.

---

<sup>1</sup> NERC Reliability Standard FAC-~~10-014-2~~ – Establish and Communicate System Operating Limits ~~Methodology for the Planning Horizon, Requirement R3.~~

<sup>2</sup> An example of an unstable power swing is provided in the Guidelines and Technical Basis section, "Justification for Including Unstable Power Swings in the Requirements section of the Guidelines and Technical Basis."

**Rationale for R1:** The Planning Coordinator has a wide-area view and is in the position to identify generator, transformer, and transmission line BES Elements which meet the criteria, if any. The criteria-based approach is consistent with the NERC System Protection and Control Subcommittee (SPCS) technical document *Protection System Response to Power Swings*, August 2013 (“PSRPS Report”),<sup>3</sup> which recommends a focused approach to determine an at-risk BES Element. See the Guidelines and Technical Basis for a detailed discussion of the criteria.

- R2.** Each Generator Owner and Transmission Owner shall ~~determine~~: [Violation Risk Factor: High] [Time Horizon: Operations Planning]
- 2.1** Within 12 full calendar months of notification of a BES Element pursuant to Requirement R1, determine whether its load-responsive protective relay(s) applied to that BES Element meets the criteria in PRC-026-1 – Attachment B where an evaluation of that Element’s load-responsive protective relay(s) based on PRC-026-1 – Attachment B criteria has not been performed in the last five calendar years.
- 2.2** Within 12 full calendar months of becoming aware<sup>4</sup> of a generator, transformer, or transmission line BES Element that tripped in response to a stable or unstable<sup>5</sup> power swing due to the operation of its protective relay(s), determine whether its load-responsive protective relay(s) applied to that BES Element meets the criteria in PRC-026-1 – Attachment B.
- M2.** Each Generator Owner and Transmission Owner shall have dated evidence that demonstrates the evaluation was performed according to Requirement R2. Evidence may include, but is not limited to, the following documentation: apparent impedance characteristic plots, email, design drawings, facsimiles, R-X plots, software output, records, reports, transmittals, lists, settings sheets, or spreadsheets.

---

<sup>3</sup> NERC System Protection and Control Subcommittee, *Protection System Response to Power Swings*, August 2013: [http://www.nerc.com/comm/PC/System%20Protection%20and%20Control%20Subcommittee%20SPCS%2020/SPCS%20Power%20Swing%20Report\\_Final\\_20131015.pdf](http://www.nerc.com/comm/PC/System%20Protection%20and%20Control%20Subcommittee%20SPCS%2020/SPCS%20Power%20Swing%20Report_Final_20131015.pdf)

<sup>4</sup> Some examples of the ways an entity may become aware of a power swing are provided in the Guidelines and Technical Basis section, “Becoming Aware of an Element That Tripped in Response to a Power Swing.”

<sup>5</sup> An example of an unstable power swing is provided in the Guidelines and Technical Basis section, “Justification for Including Unstable Power Swings in the Requirements section of the Guidelines and Technical Basis.”

**Rationale for R2:** The Generator Owner and Transmission Owner are in a position to determine whether ~~it~~their load-responsive protective relays meet the PRC-026-1 – Attachment B criteria. Generator, transformer, and transmission line BES Elements are identified by the Planning Coordinator in Requirement R1 and by the Generator Owner and Transmission Owner following an actual event where the Generator Owner and Transmission Owner became aware (i.e., through an event analysis or Protection System review) tripping was due to a stable or unstable power swing. A period of 12 calendar months allows sufficient time for ~~protection staff~~the entity to conduct the evaluation.

**R3.** Each Generator Owner and Transmission Owner shall, within six full calendar months of determining a load-responsive protective relay does not meet the PRC-026-1 – Attachment B criteria pursuant to Requirement R2, develop a Corrective Action Plan (CAP) to meet one ~~or more~~ of the following: [*Violation Risk Factor: Medium*] [*Time Horizon: Operations Planning*]

- The Protection System meets the PRC-026-1 – Attachment B criteria, while maintaining dependable fault detection and dependable out-of-step tripping (if out-of-step tripping is applied at the terminal of the BES Element); or
- The Protection System is excluded under the PRC-026-1 – Attachment A criteria (e.g., modifying the Protection System so that relay functions are supervised by power swing blocking or using relay systems that are immune to power swings), while maintaining dependable fault detection and dependable out-of-step tripping (if out-of-step tripping is applied at the terminal of the BES Element).

**M3.** The Generator Owner and Transmission Owner shall have dated evidence that demonstrates the development of a CAP in accordance with Requirement R3. Evidence may include, but is not limited to, the following documentation: corrective action plans, maintenance records, settings sheets, project or work management program records, or work orders.

**Rationale for R3:** To meet the reliability purpose of the standard, a CAP is necessary to ensure the entity’s Protection System meets the PRC-026-1 – Attachment B criteria (1<sup>st</sup> bullet) so that protective relays are expected to not trip in response to stable power swings. A CAP may also be developed to modify the Protection System for exclusion under PRC-026-1 – Attachment A (2<sup>nd</sup> bullet). Such an exclusion will allow the Protection System to be exempt from the Requirement for future events. The phrase, “...while maintaining dependable fault detection and dependable out-of-step tripping...” in Requirement ~~R2~~R3 describes that the entity is to comply with this standard, while achieving their desired protection goals. Refer to the Guidelines and Technical Basis, Introduction, for more information.

- R4.** Each Generator Owner and Transmission Owner shall implement each CAP developed pursuant to Requirement R3 and update each CAP if actions or timetables change until all actions are complete. [*Violation Risk Factor: Medium*][*Time Horizon: Long-Term Planning*]
- M4.** The Generator Owner and Transmission Owner shall have dated evidence that demonstrates implementation of each CAP according to Requirement R4, including updates to the CAP when actions or timetables change. Evidence may include, but is not limited to, the following documentation: corrective action plans, maintenance records, settings sheets, project or work management program records, or work orders.

**Rationale for R4:** Implementation of the CAP must accomplish all identified actions to be complete to achieve the desired reliability goal. During the course of implementing a CAP, updates may be necessary for a variety of reasons such as new information, scheduling conflicts, or resource issues. Documenting CAP changes and completion of activities provides measurable progress and confirmation of completion.

## C. Compliance

### 1. Compliance Monitoring Process

#### 1.1. Compliance Enforcement Authority

As defined in the NERC Rules of Procedure, “Compliance Enforcement Authority” (CEA) means NERC or the Regional Entity in their respective roles of monitoring and enforcing compliance with the NERC Reliability Standards.

#### 1.2. Evidence Retention

The following evidence retention periods identify the period of time an entity is required to retain specific evidence to demonstrate compliance. For instances where the evidence retention period specified below is shorter than the time since the last audit, the CEA may ask an entity to provide other evidence to show that it was compliant for the full time period since the last audit.

The Generator Owner, Planning Coordinator, and Transmission Owner shall keep data or evidence to show compliance as identified below unless directed by its CEA to retain specific evidence for a longer period of time as part of an investigation.

- The Planning Coordinator shall retain evidence of Requirement R1 for a minimum of one calendar year following the completion of the Requirement.
- The Generator Owner and Transmission Owner shall retain evidence of Requirement R2 evaluation for a minimum of 12 calendar months following completion of each evaluation where a CAP is not developed.

- The Generator Owner and Transmission Owner shall retain evidence of Requirements R2, R3, and R4 for a minimum of 12 calendar months following completion of each CAP.

If a Generator Owner, Planning Coordinator, or Transmission Owner is found non-compliant, it shall keep information related to the non-compliance until mitigation is complete and approved, or for the time specified above, whichever is longer.

The CEA shall keep the last audit records and all requested and submitted subsequent audit records.

**1.3. Compliance Monitoring and Assessment Processes:**

As defined in the NERC Rules of Procedure; “Compliance Monitoring and Assessment Processes” refers to the identification of the processes that will be used to evaluate data or information for the purpose of assessing performance or outcomes with the associated reliability standard.

**1.4. Additional Compliance Information**

None.

Table of Compliance Elements

R#	Time Horizon	VRF	Violation Severity Levels			
			Lower VSL	Moderate VSL	High VSL	Severe VSL
R1	Long-term Planning	Medium	The Planning Coordinator provided notification of the BES Element(s) in accordance with Requirement R1, but was less than or equal to 30 calendar days late.	The Planning Coordinator provided notification of the BES Element(s) in accordance with Requirement R1, but was more than 30 calendar days and less than or equal to 60 calendar days late.	The Planning Coordinator provided notification of the BES Element(s) in accordance with Requirement R1, but was more than 60 calendar days and less than or equal to 90 calendar days late.	The Planning Coordinator provided notification of the BES Element(s) in accordance with Requirement R1, but was more than 90 calendar days late.  OR  The Planning Coordinator failed to provide notification of the BES Element(s) in accordance with Requirement R1.



R#	Time Horizon	VRF	Violation Severity Levels			
			Lower VSL	Moderate VSL	High VSL	Severe VSL
<b>R2</b>	Operations Planning	High	The Generator Owner or Transmission Owner evaluated its load-responsive protective relay(s) in accordance with Requirement R2, but was less than or equal to 30 calendar days late.	The Generator Owner or Transmission Owner evaluated its load-responsive protective relay(s) in accordance with Requirement R2, but was more than 30 calendar days and less than or equal to 60 calendar days late.	The Generator Owner or Transmission Owner evaluated its load-responsive protective relay(s) in accordance with Requirement R2, but was more than 60 calendar days and less than or equal to 90 calendar days late.	The Generator Owner or Transmission Owner evaluated its load-responsive protective relay(s) in accordance with Requirement R2, but was more than 90 calendar days late.  OR The Generator Owner or Transmission Owner failed to evaluate its load-responsive protective relay(s) in accordance with Requirement R2.

R#	Time Horizon	VRF	Violation Severity Levels			
			Lower VSL	Moderate VSL	High VSL	Severe VSL
<b>R3</b>	Long-term Planning	Medium	The Generator Owner or Transmission Owner developed a Corrective Action Plan (CAP) in accordance with Requirement R3, but in more than six calendar months and less than or equal to seven calendar months.	The Generator Owner or Transmission Owner developed a Corrective Action Plan (CAP) in accordance with Requirement R3, but in more than seven calendar months and less than or equal to eight calendar months.	The Generator Owner or Transmission Owner developed a Corrective Action Plan (CAP) in accordance with Requirement R3, but in more than eight calendar months and less than or equal to nine calendar months.	The Generator Owner or Transmission Owner developed a Corrective Action Plan (CAP) in accordance with Requirement R3, but in more than nine calendar months.  OR The Generator Owner or Transmission Owner failed to develop a CAP in accordance with Requirement R3.
<b>R4</b>	Long-term Planning	Medium	The Generator Owner or Transmission Owner implemented a Corrective Action Plan (CAP), but failed to update a CAP when actions or timetables changed, in accordance with Requirement R4.	N/A	N/A	The Generator Owner or Transmission Owner failed to implement a Corrective Action Plan (CAP) in accordance with Requirement R4.

#### D. Regional Variances

None.

#### E. Interpretations

None.

#### F. Associated Documents

*Applied Protective Relaying*, Westinghouse Electric Corporation, 1979.

Burdy, John, *Loss-of-excitation Protection for Synchronous Generators GER-3183*, General Electric Company.

IEEE Power System Relaying Committee WG D6, *Power Swing and Out-of-Step Considerations on Transmission Lines*, July 2005: <http://www.pes-psrc.org/Reports/Power%20Swing%20and%20OOS%20Considerations%20on%20Transmission%20Lines%20F..pdf>.

Kimbark Edward Wilson, *Power System Stability, Volume II: Power Circuit Breakers and Protective Relays*, Published by John Wiley and Sons, 1950.

Kundur, Prabha, *Power System Stability and Control*, 1994, Palo Alto: EPRI, McGraw Hill, Inc.

NERC System Protection and Control Subcommittee, *Protection System Response to Power Swings*, August 2013: [http://www.nerc.com/comm/PC/System%20Protection%20and%20Control%20Subcommittee%20SPCS%2020/SPCS%20Power%20Swing%20Report\\_Final\\_20131015.pdf](http://www.nerc.com/comm/PC/System%20Protection%20and%20Control%20Subcommittee%20SPCS%2020/SPCS%20Power%20Swing%20Report_Final_20131015.pdf).

Reimert, Donald, *Protective Relaying for Power Generation Systems*, 2006, Boca Raton: CRC Press.

### PRC-026-1 – Attachment A

This standard applies to any protective functions which could trip instantaneously or with a time delay of less than 15 cycles on load current (i.e., “load-responsive”) including, but not limited to:

- Phase distance
- Phase overcurrent
- Out-of-step tripping
- Loss-of-field

The following protection functions are excluded from Requirements of this standard:

- Relay elements supervised by power swing blocking
- Relay elements that are only enabled when other relays or associated systems fail. For example:
  - Overcurrent elements that are only enabled during loss of potential conditions.
  - Relay elements that are only enabled during a loss of communications
- Thermal emulation relays which are used in conjunction with dynamic Facility Ratings
- Relay elements associated with direct current (dc) lines
- Relay elements associated with dc converter transformers
- Phase fault detector relay elements employed to supervise other load-responsive phase distance elements (i.e.g., in order to prevent false operation in the event of a loss of potential) ~~provided the distance element is set in accordance with the criteria outlined in the standard~~
- Relay elements associated with switch-onto-fault schemes
- Reverse power relay on the generator
- Generator relay elements that are armed only when the generator is disconnected from the system, (e.g., non-directional overcurrent elements used in conjunction with inadvertent energization schemes, and open breaker flashover schemes)
- Current differential relay, pilot wire relay, and phase comparison relay
- Voltage-restrained or voltage-controlled overcurrent relays

PRC-026-1 – Attachment B

**Criteria**Criterion A:

An impedance-based relay used for tripping is expected to not trip for a stable power swing, when the relay characteristic is completely contained within the unstable power swing region.<sup>6</sup> The unstable power swing region is formed by the union of three shapes in the impedance (R-X) plane; (1) a lower loss-of-synchronism circle based on a ratio of the sending-end to receiving-end voltages of 0.7; (2) an upper loss-of-synchronism circle based on a ratio of the sending-end to receiving-~~end to sending~~-end voltages of 1.43; (3) a lens that connects the endpoints of the total system impedance (with the parallel transfer impedance removed) bounded by varying the sending-end and receiving-end voltages from 0.0 to 1.0 per unit, while maintaining a constant system separation angle across the total system impedance where:

1. The system separation angle is:
  - At least 120 degrees, or
  - An angle less than 120 degrees where a documented transient stability analysis demonstrates that the expected maximum stable separation angle is less than 120 degrees.
2. All generation is in service and all transmission BES Elements are in their normal operating state when calculating the system impedance.
3. Saturated (transient or sub-transient) reactance is used for all machines.

**Rationale for Attachment B (CriteriaCriterion A):** The PRC-026-1 – Attachment B, CriteriaCriterion A provides a basis for determining if the relays are expected to not trip for a stable power swing having a system separation angle of up to 120 degrees with the sending-end and receiving-end voltages varying from 0.7 to 1.0 per unit (See Guidelines and Technical Basis).

---

<sup>6</sup> Guidelines and Technical Basis, Figures 1 and 2.

## PRC-026-1 – Attachment B

### Criteria Criterion B:

The pickup of an overcurrent relay element used for tripping, that is above the calculated current value (with the parallel transfer impedance removed) for the conditions below:

1. The system separation angle is:
  - At least 120 degrees, or
  - An angle less than 120 degrees where a documented transient stability analysis demonstrates that the expected maximum stable separation angle is less than 120 degrees.
2. All generation is in service and all transmission BES Elements are in their normal operating state when calculating the system impedance.
3. Saturated (transient or sub-transient) reactance is used for all machines.
4. Both the sending-end and receiving-end voltages at 1.05 per unit.

**Rationale for Attachment B (Criteria Criterion B):** The PRC-026-1 – Attachment B, Criteria Criterion B provides a basis for determining if the relays are expected to not trip for a stable power swing having a system separation angle of up to 120 degrees with the sending-end and receiving-end voltages at 1.05 per unit (See Guidelines and Technical Basis).

### Guidelines and Technical Basis

#### Introduction

The NERC System Protection and Control Subcommittee technical document, *Protection System Response to Power Swings*, August 2013,<sup>7</sup> (“PSRPS Report” or “report”) was specifically prepared to support the development of this NERC Reliability Standard. The report provided a historical perspective on power swings as early as 1965 up through the approval of the report by the NERC Planning Committee. The report also addresses reliability issues regarding trade-offs between security and dependability of Protection Systems, considerations for this NERC Reliability Standard, and a collection of technical information about power swing characteristics and varying issues with practical applications and approaches to power swings. Of these topics, the report suggests an approach for this NERC Reliability Standard (“standard” or “PRC-026-1”) which is consistent with addressing ~~two of the~~ three regulatory directives in the FERC Order No. 733. The first directive concerns the need for “...protective relay systems that differentiate between faults and stable power swings and, when necessary, phases out protective relay systems that cannot meet this requirement.”<sup>8</sup> Second, is “...to develop a Reliability Standard addressing undesirable relay operation due to stable power swings.”<sup>9</sup> The third directive “...to consider “islanding” strategies that achieve the fundamental performance for all islands in developing the new Reliability Standard addressing stable power swings”<sup>10</sup> was considered during development of the standard.

The development of this standard implements the majority of the approaches suggested by the report. However, it is noted that the Reliability Coordinator and Transmission Planner have not been included in the standard’s Applicability section (as suggested by the PSRPS Report). This is so that a single entity, the Planning Coordinator, may be the single source for identifying Elements according to Requirement R1. A single source will insure that multiple entities will not identify Elements in duplicate, nor will one entity fail to provide an Element because it believes the Element is being provided by another entity. The Planning Coordinator has, or has access to, the wide-area model and can correctly identify the Elements that may be susceptible to a stable or unstable power swing. Additionally, not including the Reliability Coordinator and Transmission Planner is consistent with the applicability of other relay loadability NERC Reliability Standards (e.g., PRC-023 and PRC-025). It is also consistent with the NERC Functional Model.

The phrase, “while maintaining dependable fault detection and dependable out-of-step tripping” in Requirement ~~R2R3~~, describes that the Generator Owner and Transmission Owner ~~is~~are to comply with this standard; while achieving its desired protection goals. Load-responsive protective relays, as addressed within this standard, may be intended to provide a variety of backup protection functions, both within the generating unit or generating plant and on the transmission system, and

---

<sup>7</sup> NERC System Protection and Control Subcommittee, *Protection System Response to Power Swings*, August 2013: [http://www.nerc.com/comm/PC/System%20Protection%20and%20Control%20Subcommittee%20SPCS%2020/SPCS%20Power%20Swing%20Report\\_Final\\_20131015.pdf](http://www.nerc.com/comm/PC/System%20Protection%20and%20Control%20Subcommittee%20SPCS%2020/SPCS%20Power%20Swing%20Report_Final_20131015.pdf)

<sup>8</sup> Transmission Relay Loadability Reliability Standard, Order No. 733, P.150 FERC ¶ 61,221 (2010).

<sup>9</sup> Ibid. P.153.

<sup>10</sup> Ibid. P.162.

this standard is not intended to result in the loss of these protection functions. Instead, ~~it is suggested that~~ the Generator Owner and Transmission Owner must consider both the Requirements within this standard and its desired protection goals, and perform modifications to its protective relays or protection philosophies as necessary to achieve both.

### Power Swings

The IEEE Power System Relaying Committee WG D6 developed a technical document called *Power Swing and Out-of-Step Considerations on Transmission Lines* (July 2005) that provides background on power swings. The following are general definitions from that document:<sup>11</sup>

**Power Swing:** a variation in three phase power flow which occurs when the generator rotor angles are advancing or retarding relative to each other in response to changes in load magnitude and direction, line switching, loss of generation, faults, and other system disturbances.

**Pole Slip:** a condition whereby a generator, or group of generators, terminal voltage angles (or phases) go past 180 degrees with respect to the rest of the connected power system.

**Stable Power Swing:** a power swing is considered stable if the generators do not slip poles and the system reaches a new state of equilibrium, i.e. an acceptable operating condition.

**Unstable Power Swing:** a power swing that will result in a generator or group of generators experiencing pole slipping for which some corrective action must be taken.

**Out-of-Step Condition:** Same as an unstable power swing.

**Electrical System Center or Voltage Zero:** it is the point or points in the system where the voltage becomes zero during an unstable power swing.

### Burden to Entities

The PSRPS Report provides a technical basis and approach for focusing on Protection Systems, which are susceptible to power swings, while achieving the purpose of the standard. The approach reduces the number of relays to which the PRC-026-1 Requirements would apply by first identifying the BES Element(s) on which load-responsive protective relays must be evaluated. The first step uses criteria to identify the Elements on which a Protection System is expected to be challenged by power swings. Of those Elements, the second step is to evaluate each load-responsive protective relay that is applied on each identified Element. Rather than requiring the Planning Coordinator or Transmission Planner to perform simulations to obtain information for each identified Element, the Generator Owner and Transmission Owner will reduce the need for simulation by comparing the load-responsive protective relay characteristic to specific criteria in PRC-026-1 – Attachment B.

---

<sup>11</sup> <http://www.pes-psrc.org/Reports/Power%20Swing%20and%20OOS%20Considerations%20on%20Transmission%20Lines%20F..pdf>.



### Applicability

The standard is applicable to the Generator Owner, Planning Coordinator, and Transmission Owner entities. More specifically, the Generator Owner and Transmission Owner entities are applicable when applying load-responsive protective relays at the terminals of the applicable BES Elements. The standard is applicable to the following BES Elements: generators, transformers, and transmission lines. The Distribution Provider was considered for inclusion in the standard; however, it is not subject to the standard because this entity, by functional registration, would not own generators, transmission lines, or transformers other than load serving.

Load-responsive protective relays include any protective functions which could trip with or without time delay, on load current.

### Requirement R1

The Planning Coordinator has a wide-area view and is in the ~~position~~ position to identify what, if any, Elements meet the criteria. The criterion-based approach is consistent with the NERC System Protection and Control Subcommittee (SPCS) technical document, *Protection System Response to Power Swings* (August 2013),<sup>12</sup> which recommends a focused approach to determine an at-risk Element. Identification of Elements comes from the annual Planning Assessments pursuant to the transmission planning (i.e., “TPL”) and other NERC Reliability Standards (e.g., PRC-006), and the standard is not requiring any other assessments to be performed by the Planning Coordinator. The required notification on a calendar year basis to the respective Generator Owner and Transmission Owner is sufficient because it is expected that the Planning Coordinator will make its notifications following the completion of its annual Planning Assessments. The Planning Coordinator will continue to provide notification of Elements on a calendar year basis even if a study is performed less frequently (e.g., PRC-006 – Automatic Underfrequency Load Shedding, which is five years) and has not changed. It is possible that ~~the~~ Planning Coordinator ~~provided notification of Elements could utilize studies from a prior year in two different calendar years using the same annual Planning Assessment determining the necessary notifications pursuant to Requirement R1.~~ provided notification of Elements could utilize studies from a prior year in two different calendar years using the same annual Planning Assessment determining the necessary notifications pursuant to Requirement R1.

### Criterion 1

The first criterion involves generator(s) where an angular stability constraint exists that is addressed by a System Operating Limit (SOL) or a Remedial Action Scheme (RAS) and those Elements terminating at the Transmission station associated with the generator(s). For example, a scheme to remove generation for specific conditions is implemented for a four-unit generating plant (1,100 MW). Two of the units are 500 MW each; one is connected to the 345 kV system and one is connected to the 230 kV system. The Transmission Owner has two 230 kV transmission lines and one 345 kV transmission line all terminating at the generating facility as well as a 345/230 kV autotransformer. The remaining 100 MW consists of two 50 MW combustion turbine (CT) units connected to four 66 kV transmission lines. The 66 kV transmission ~~line is~~ lines are not

---

<sup>12</sup> [http://www.nerc.com/comm/PC/System%20Protection%20and%20Control%20Subcommittee%20SPCS%20/SPCS%20Power%20Swing%20Report\\_Final\\_20131015.pdf](http://www.nerc.com/comm/PC/System%20Protection%20and%20Control%20Subcommittee%20SPCS%20/SPCS%20Power%20Swing%20Report_Final_20131015.pdf)

electrically joined to the 345 kV and 230 kV transmission lines at the plant site and ~~is~~ are not a part of ~~subject to~~ the operating limit or RAS. A stability constraint limits the output of the portion of the plant affected by the RAS to 700 MW for an outage of the 345 kV transmission line. The RAS trips one of the 500 MW units to maintain stability for a loss of the 345 kV transmission line when the total output from both 500 MW units is above 700 MW. For this example, both 500 MW generating units and the associated generator step-up (GSU) transformers would be identified as Elements meeting this criterion. The 345/230 kV autotransformer, the 345 kV transmission line, and the two 230 kV transmission lines would also be identified as Elements meeting this criterion. The 50 MW combustion turbines and 66 kV transmission lines would not be identified pursuant to Criterion 1 because these Elements are not subject to an operating limit or RAS and do not terminate at the Transmission station associated with the generators that are subject to the SOL or RAS.

### Criterion 2

The second criterion involves Elements that are monitored as a part of an established System Operating Limit (SOL) based on an angular stability limit regardless of the outage conditions that result in the enforcement of the SOL. For example, if two long parallel 500 kV transmission lines have a combined SOL of 1,200 MW, and this limit is based on angular instability resulting from a fault and subsequent loss of one of the two lines, then both lines would be identified as ~~an~~ Element/Elements meeting the criterion.

### Criterion 3

The third criterion involves Elements that form the boundary of an island within an underfrequency load shedding (UFLS) design assessment. The criterion applies to islands identified based on application of the Planning Coordinator's criteria for identifying islands, where the island is formed by tripping the Elements based on angular instability. The criterion applies if the angular instability is modeled in the UFLS design assessment, or if the boundary is identified "off-line" (i.e., the Elements are selected based on angular instability considerations, but the Elements are tripped in the UFLS design assessment without modeling the initiating angular instability). In cases where an out-of-step condition is detected and tripping is initiated at an alternate location, the criterion applies to the Element on which the power swing is detected. The criterion does not apply to islands identified based on other considerations that do not involve angular instability, such as excessive loading, Planning Coordinator area boundary tie lines, or Balancing Authority boundary tie lines.

### Criterion 4

The fourth criterion involves Elements identified in the most recent annual Planning Assessment where relay tripping occurs due to a stable or unstable<sup>13</sup> power swing during a simulated disturbance. The intent is for the Planning Coordinator to include any Element(s) where relay

---

<sup>13</sup> Refer to the "Justification for Including Unstable Power Swings in the Requirements" section.

tripping was observed during simulations performed for the most recent annual Planning Assessment associated with the transmission planning TPL-001-4 Reliability Standard. Note that relay tripping must be assessed within those annual Planning Assessments per TPL-001-4, R4, Part 4.3.1.3, which indicates that analysis shall include the “Tripping of Transmission lines and transformers where transient swings cause Protection System operation based on generic or actual relay models.” Identifying such Elements according to Criterion 4 and notifying the respective Generator Owner and Transmission Owner will require that the owners of any load-responsive protective relay applied at the terminals of the identified Element evaluate the relay’s susceptibility to tripping in response to a stable power swing.

Planning Coordinators have the discretion to determine whether the observed tripping for a power swing in its Planning Assessments occurs for valid contingencies and system conditions. The Planning Coordinator will address tripping that is observed in transient analyses on an individual basis; therefore, the Planning Coordinator is responsible for identifying the Elements based only on simulation results that are determined to be valid.

Due to the nature of how a Planning Assessment is performed, there may be cases where a previously-identified Element is not identified in the most recent annual Planning Assessment. If so, this is acceptable because the Generator Owner and Transmission Owner would have taken action upon the initial notification of the previously identified Element. When an Element is not identified in later Planning Assessments, the risk of load-responsive protective relays tripping in response to a stable power swing during non-Fault conditions would have already been assessed under Requirement R2 and mitigated according to Requirements R3 and R4 where the relays did not meet the PRC-026-1 – Attachment B criteria. According to Requirement R2, the Generator Owner and Transmission Owner are only required to re-evaluate each load-responsive protective relay for an identified Element where the evaluation has not been performed in the last five calendar years.

Although Requirement R1 requires the Planning Coordinator to notify the respective Generator Owner and Transmission Owner of any Elements meeting one or more of the four criteria, it does not preclude the Planning Coordinator from providing additional information, such as apparent impedance characteristics, in advance or upon request, that may be useful in evaluating protective relays. Generator Owners and Transmission Owners are able to complete protective relay evaluations and perform the required actions without additional information. The standard does not include any requirement for the entities to provide information that is already being shared or exchanged between entities for operating needs. While a Requirement has not been included for the exchange of information, entities should recognize that relay performance needs to be measured against the most current information.

### Requirement R2

Requirement R2 requires the Generator Owner and Transmission Owner to evaluate its load-responsive protective relays to ensure that they are expected to not trip in response to stable power swings.

The PRC-026-1 – Attachment A lists the applicable load-responsive relays that must be evaluated. ~~These relays which~~ include phase distance, phase overcurrent, out-of-step tripping, and loss-of-field. ~~relay functions~~. Phase distance relays ~~can~~ could include, but are not limited to, the following:

- ~~Mho element characteristics such as Zone 1, Zone 2, or Zone 3 elements~~ with instantaneous tripping or intentional time delays of less than 15 cycles ~~or less~~.
- ~~Mho element characteristics that overreach the remote line terminal~~ Phase distance elements used in high-speed, ~~communications-assisted~~ communication-aided tripping schemes including:
  - Directional Comparison Blocking (DCB) schemes
  - Directional Comparison Un-Blocking (DCUB) schemes
  - Permissive Overreach Transfer Trip (POTT) schemes
  - Permissive Underreach Transfer Trip (PUTT) schemes

A method is provided within the standard to support consistent evaluation by Generator Owners and Transmission Owners based on specified conditions. Once a Generator Owner or Transmission Owner is notified of Elements pursuant to Requirement R1, it has 12 full calendar months to determine if each Element's load-responsive protective relays meet the ~~applicable~~ PRC-026-1 – Attachment B criteria, if the determination has not been performed in the last five calendar years. Additionally, each Generator Owner and Transmission Owner, that becomes aware of a generator, transformer, or transmission line BES Element that tripped in response to a stable or unstable power swing due to the operation of its protective relays pursuant to Requirement R2, Part 2.2, must perform the same PRC-026-1 – Attachment B criteria determination within 12 full calendar months.

### Becoming Aware of an Element That Tripped in Response to a Power Swing

Part 2.2 in Requirement R2 is intended to initiate action by the Generator Owner and Transmission Owner when there is a known stable or unstable power swing and it resulted in the entity's Element tripping. The criterion starts with becoming aware of the event (i.e., power swing) and then any connection with the entity's Element tripping. By doing so, the focus is removed from the entity having to demonstrate that it ~~performed~~ made a determination whether a power swing ~~analysis was~~ present for every Element trip. The basis for structuring the criterion in this manner is driven by the available ways that a Generator Owner and Transmission Owner could become aware of an Element that tripped in response to a stable or unstable power swing due to the operation of its protective relay(s).

Element trips caused by stable or unstable power swings, though infrequent, would be more common in a larger event. The identification of power swings will be revealed during an analysis of the event. Event analysis where an entity may become aware of a stable or unstable power swing could include internal analysis conducted by the entity, the entity's Protection System review following a trip, or a larger scale analysis which includes by other entities. Event analysis could include involvement by the entity's Regional Entity, and in some cases NERC.

### Information Common to Both Generation and Transmission Elements

The PRC-026-1 – Attachment A lists the load-responsive protective relays that are subject to this standard. Generator Owners and Transmission Owners may own load-responsive protective relays (i.e., distance relays) that directly affect generation or transmission BES Elements and will require analysis as a result of Elements being identified by the Planning Coordinator in Requirement R1 or the Generator Owner or Transmission Owner in Requirement R2. For example, distance relays owned by the Transmission Owner may be installed at the high-voltage side of the generator step-up (GSU) transformer (directional toward the generator) providing backup to generation protection. Generator Owners may have distance relays applied to backup transmission protection or backup protection to the GSU transformer. The Generator Owner may have relays installed at the generator terminals or the high-voltage side of the GSU transformer.

### Exclusion of Time Based Load-Responsive Protective Relays

The purpose of the standard is “[t]o ensure that load-responsive protective relays are expected to not trip in response to stable power swings during non-Fault conditions.” Load-responsive, high-speed tripping protective relays pose the highest risk of operating during a power swing. Because of this, high-speed tripping protective relays and relays with a time delay of less than 15 cycles are included in the standard; whereas other relays (i.e., Zones 2 and 3) with a time delay of 15 cycles or greater are excluded. The time delay used for exclusion on some load-responsive protective relays is ~~recommended based on 1) the minimum time delay these relays are set in practice, and 2) based on~~ the maximum expected time that load-responsive protective relays would be exposed to a stable power swing ~~based on with a swingslow slip rate frequency.~~

In order to establish a time delay that distinguishes a high-risk load-responsive protective relay from one that has a time delay for tripping (lower-risk), a sample of swing rates were calculated based on a stable power swing entering and leaving the impedance characteristic as shown in Table 1. For a relay impedance characteristic that has ~~the~~ power swing entering and leaving, beginning at 90 degrees with a termination at 120 degrees before exiting the zone, ~~calculation of the zone~~ timer must be greater than the ~~calculated~~ time the stable power swing is inside the ~~relay operate zone~~ relay’s operating zone to not trip in response to the stable power swing.

$$\text{Eq. (1)} \quad \text{Zone timer} > 2 \times \left( \frac{(120^\circ - \text{Angle of entry into the relay characteristic}) \times 60}{(360 \times \text{Slip Rate})} \right)$$

Table 1: Swing Rates	
Zone Timer (Cycles)	Slip Rate (Hz)
10	1.00
15	0.67
20	0.50
30	0.33

With a minimum zone timer of 15 cycles, the corresponding slip rate of the system is 0.67 Hz. This represents an approximation of a slow slip rate during a system Disturbance. ~~Consequently, this value corresponds to the typical minimum time delay used for Zone 2 distance relays in transmission line protection.~~ Longer time delays allow for slower slip rates.

### Application to Transmission Elements

~~Criteria~~Criterion A in PRC-026-1 – Attachment B describes an unstable power swing region that is formed by the union of three shapes in the impedance (R-X) plane. The first shape is a lower loss-of-synchronism circle based on a ratio of the sending-end to receiving-end voltages of 0.7 (i.e.,  $E_S / E_R = 0.7 / 1.0 = 0.7$ ). The second shape is an upper loss-of-synchronism circle based on a ratio of the ~~sending-end to receiving-end~~ ~~to sending-end~~ voltages of 1.43 (i.e.,  $E_S / E_R = 1.0 / 0.7 = 1.43$ ). The third shape is a lens that connects the endpoints of the total system impedance together by varying the sending-end and receiving-end system voltages from 0.0 to 1.0 per unit, while maintaining a constant system separation angle across the total system impedance (with the parallel transfer impedance removed—see Figures 1 through 5). The total system impedance is derived from a two-bus equivalent network and is determined by summing the sending-end source impedance, the line impedance (excluding the Thévenin equivalent transfer impedance), and the receiving-end source impedance as shown in Figures 6 and 7. ~~The goal in establishing~~Establishing the total system impedance ~~is to represent~~provides a conservative condition that will maximize the security of the relay against various system conditions. The smallest total system impedance represents a condition where the size of the lens characteristic in the R-X plane is smallest and is a conservative operating point from the standpoint of ensuring a load-responsive protective relay is expected to not trip given a predetermined angular displacement between the sending-end and receiving-end voltages. The smallest total system impedance results when all generation is in service and all transmission BES Elements are modeled in their “normal” system configuration (PRC-026-1 – Attachment B, ~~Criteria~~Criterion A). The parallel transfer impedance is removed to represent a likely condition where parallel ~~elements~~Elements may be lost during the disturbance, and the loss of these ~~elements~~Elements magnifies the sensitivity of the load-responsive relays on the parallel line by removing the “infeed effect” (i.e., the apparent impedance sensed by the relay is decreased as a result of the loss of the transfer impedance, thus making the relay more likely to trip for a stable power swing—See Figures 13 and 14).

The sending-end and receiving-end source voltages are varied from 0.7 to 1.0 per unit to form the lower and upper loss-of-synchronism circles. The ratio of these two voltages is used in the calculation of the loss-of-synchronism circles, and result in a ratio range from 0.7 to 1.43.

Eq. (2) 
$$\frac{E_S}{E_R} = \frac{0.7}{1.0} = 0.7$$

Eq. (3): 
$$\frac{E_R}{E_S} = \frac{1.0}{0.7} = 1.43$$

The internal generator voltage during severe power swings or transmission system fault conditions will be greater than zero, due to voltage regulator support. The voltage ratio of 0.7 to 1.43 is chosen

## PRC-026-1 – Application Guidelines

---

to be more conservative than the PRC-023<sup>14</sup> and PRC-025<sup>15</sup> NERC Reliability Standards, where a lower bound voltage of 0.85 per unit voltage is used. A  $\pm 15\%$  internal generator voltage range was chosen as a conservative voltage range for calculation of the voltage ratio used to calculate the loss-of-synchronism circles. For example, the voltage ratio using these voltages would result in a ratio range from 0.739 to 1.353.

$$\text{Eq. (4)} \quad \frac{E_S}{E_R} = \frac{0.85}{1.15} = 0.739$$

$$\text{Eq. (5):} \quad \frac{\frac{E_R}{E_S} E_S}{\frac{E_S}{E_R} E_R} = \frac{1.15}{0.85} = 1.353$$

The lower ratio is rounded down to 0.7 to be more conservative, allowing a voltage range of 0.7 to 1.0 per unit to be used for the calculation of the loss-of-synchronism circles.<sup>16</sup>

When the parallel transfer impedance is included in the model, the ~~split-division of~~ current through the parallel transfer impedance path results in actual measured relay impedances that are larger than those measured when the parallel transfer impedance is removed (i.e., infeed effect), which would make it more likely for an impedance relay element to be completely contained within the unstable power swing region as shown in Figure 11. If the transfer impedance is included in the evaluation, a distance relay element could be deemed as meeting PRC-026-1 – Attachment B criteria and, in fact would be secure, assuming all ~~elements~~ Elements were in their normal state. In this case, the distance relay element could trip ~~for~~ in response to a stable power swing during an actual event if the system was weakened (i.e., a higher transfer impedance) by the loss of a subset of lines that make up the parallel transfer impedance: as shown in Figure 10. This could happen because the subset of lines that make up the parallel transfer impedance tripped on unstable swings, contained the initiating fault, and/or were lost due to operation of breaker failure or remote back-up protection schemes ~~in Figure 10~~.

Table 10 shows the percent size increase of the lens shape as seen by the relay under evaluation when the parallel transfer impedance is included. The parallel transfer impedance has minimal effect on the apparent size of the lens shape as long as the parallel transfer impedance is at least 10 multiples of the parallel line impedance (less than 5% lens shape expansion), therefore, its removal has minimal impact, but results in a slightly more conservative, smaller lens shape. ~~Transfer~~ Parallel transfer impedances of 5 multiples of the parallel line impedance or less result in an apparent lens shape size of 10% or greater as seen by the relay. If two parallel lines and a parallel transfer impedance tie the sending-end and receiving-end buses together, the total parallel transfer impedance will be one or less multiples of the parallel line impedance, resulting in an apparent lens shape size of 45% or greater. It is a realistic contingency that the parallel line could be out-of-service, leaving the parallel transfer impedance making up the rest of the system in parallel with the line impedance. Since it is not known exactly which lines making up the parallel

---

<sup>14</sup> Transmission Relay Loadability

<sup>15</sup> Generator Relay Loadability

<sup>16</sup> *Final Report on the August 14, 2003 Blackout in the United States and Canada: Causes and Recommendations*, April 2004, Section 6 (The Cascade Stage of the Blackout), p. 94 under “Why the Generators Tripped Off,” states, “Some generator undervoltage relays were set to trip at or above 90% voltage. However, a motor stalls out at about 70% voltage and a motor starter contactor drops out around 75%, so if there is a compelling need to protect the turbine from the system the under-voltage trigger point should be no higher than 80%.”

transfer impedance ~~that~~ will be out of service during a major system disturbance, it is most conservative to assume that all of them are out, leaving just the line under evaluation in service.

Either the saturated transient or sub-transient direct axis reactance ~~values~~ may be used for machines in the evaluation because they are smaller than ~~the~~ un-saturated ~~reactance values~~ ~~reactances~~. Since ~~saturated~~ sub-transient ~~saturated~~ generator reactances are smaller than the transient or synchronous ~~reactance, they~~ ~~reactances~~, the use of sub-transient reactances will result in a smaller source impedance and a smaller unstable power swing region in the graphical analysis as shown in Figures 8 and 9. ~~Since~~ ~~Because~~ power swings occur in a time frame where generator transient reactances will be prevalent, it is acceptable to use saturated transient reactances instead of saturated sub-transient ~~reactance values~~ ~~Some~~ ~~reactances~~. ~~Because some~~ short-circuit models may not include transient ~~reactance values~~, ~~so in this case~~ ~~reactances~~, the use of sub-transient ~~reactances~~ is ~~also~~ acceptable because it ~~also~~ produces more conservative results ~~than transient reactances~~. For this reason, either value is acceptable when determining the system source impedances (PRC-026-1 – Attachment B, ~~Criteria~~ Criterion A and B, No. 3).

Saturated ~~reactance values~~ ~~reactances~~ are ~~also the values~~ used in short-circuit programs that produce the system impedance mentioned above. Planning and stability software generally use ~~the~~ un-saturated ~~reactance values~~ ~~reactances~~. Generator models used in transient stability analyses recognize that the extent of the saturation effect depends upon both rotor (field) and stator currents. Accordingly, they derive the effective saturated parameters of the machine at each instant by internal calculation from the specified (constant) unsaturated values of machine reactances and the instantaneous internal flux level. The specific assumptions regarding which inductances are affected by saturation, and the relative effect of that saturation, are different for the various generator models used. Thus, unsaturated values of all machine reactances are used in setting up planning and stability software data, and the appropriate set of open-circuit magnetization curve data is provided for each machine.

Saturated reactance values are smaller than unsaturated reactance values and are used in short-circuit programs owned by the Generator and Transmission Owners. Because of this, saturated reactance values are to be used in the development of the system source impedances.

The source or system equivalent impedances can be obtained by a number of different methods using commercially available short-circuit calculation tools.<sup>17</sup> Most short-circuit tools have a network reduction feature that allows the user to select the local and remote terminal buses to retain. The first method reduces the system to one that contains two buses, an equivalent generator at each bus (representing the source ~~impedance~~ ~~impedances~~ at the sending-end and receiving-~~ends~~ ~~end~~), and two parallel lines; one being the line impedance of the protected line with relays being analyzed, the other being the parallel transfer impedance representing all other combinations of lines that connect the two buses together as shown in Figure 6. Another conservative method is to open both ends of the line ~~in question~~ ~~being evaluated~~, and apply a three-phase bolted fault at each bus. ~~The resulting source~~ ~~to determine the Thévenin equivalent~~ impedance at each ~~end~~ ~~bus~~. The source impedances are set equal to the Thévenin equivalent impedances and will be less than

---

<sup>17</sup> Demetrios A. Tziouvaras and Daqing Hou, Appendix in *Out-Of-Step Protection Fundamentals and Advancements*, April 17, 2014: <https://www.selinc.com>.



or equal to the actual source ~~impedance~~impedances calculated by the network reduction method. Either method can be used to develop the system source impedances at both ends.

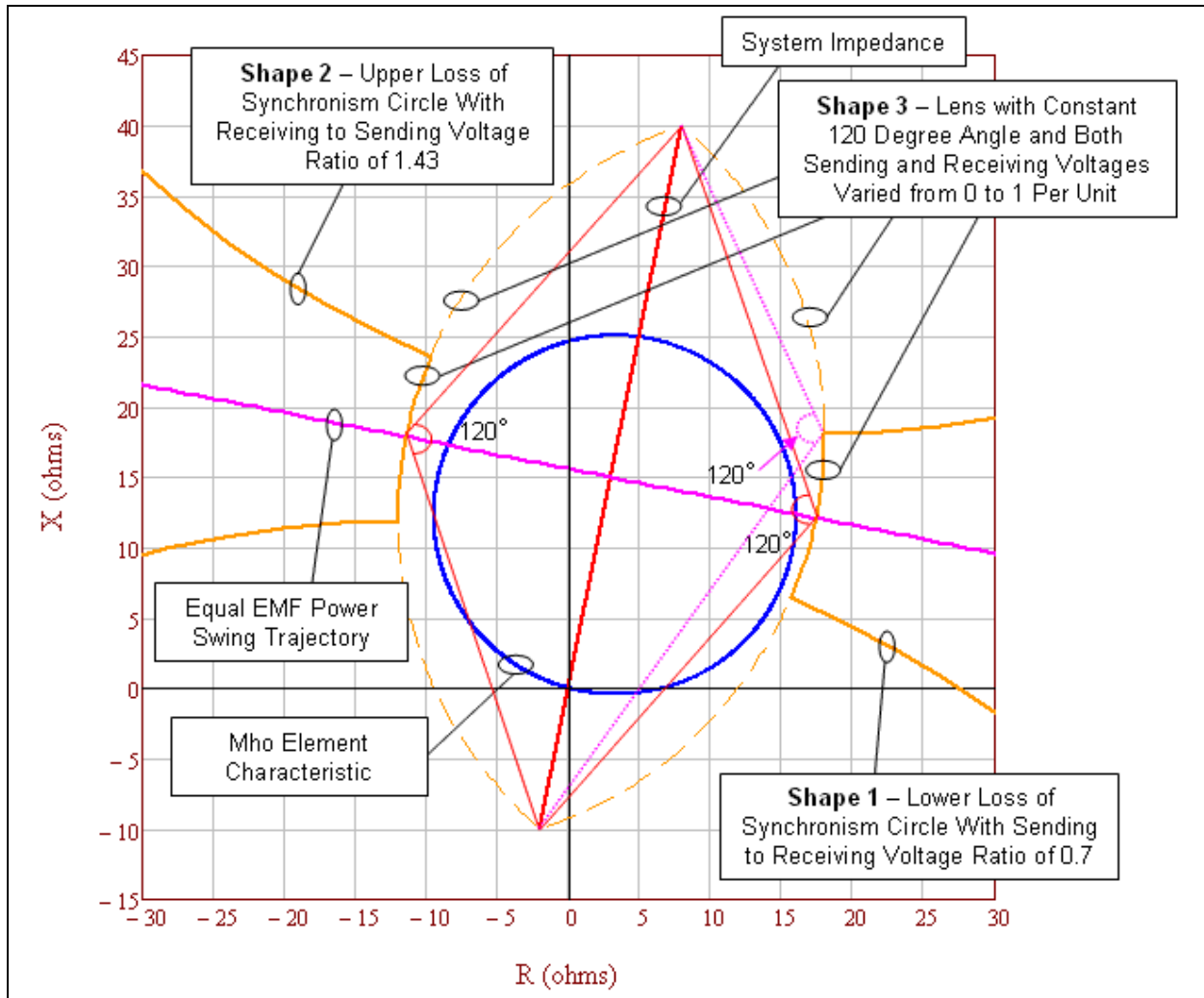
The two bullets of PRC-026-1 – Attachment B, ~~Criteria~~Criterion A, No. 1, identify the system separation angles used to identify the size of the power swing stability boundary ~~to be used to test for evaluating~~ load-responsive protective relay impedance elements. ~~Both bullets test impedance relay elements that are not supervised by power swing blocking (PSB).~~ The first bullet of PRC-026-1 – Attachment B, ~~Criteria~~Criterion A, No. 1 evaluates a system separation angle of at least 120 degrees that is held constant while varying the sending-end and receiving-end source voltages from 0.7 to 1.0 per unit, thus creating an unstable power swing region about the total system impedance in Figure 1. This unstable power swing region is compared to the tripping portion of the distance relay characteristic; that is, the portion that is not supervised by load encroachment, blinders, or some other form of supervision as shown in Figure 12 that restricts the distance element from tripping for heavy, balanced load conditions. If the tripping portion of the impedance characteristics are completely contained within the unstable power swing region, the relay impedance element meets ~~Criteria~~Criterion A in PRC-026-1 – Attachment B. A system separation angle of 120 degrees was chosen for the evaluation ~~where PSB is not applied~~ because it is generally accepted in the industry that recovery for a swing beyond this angle is unlikely to occur.<sup>18</sup>

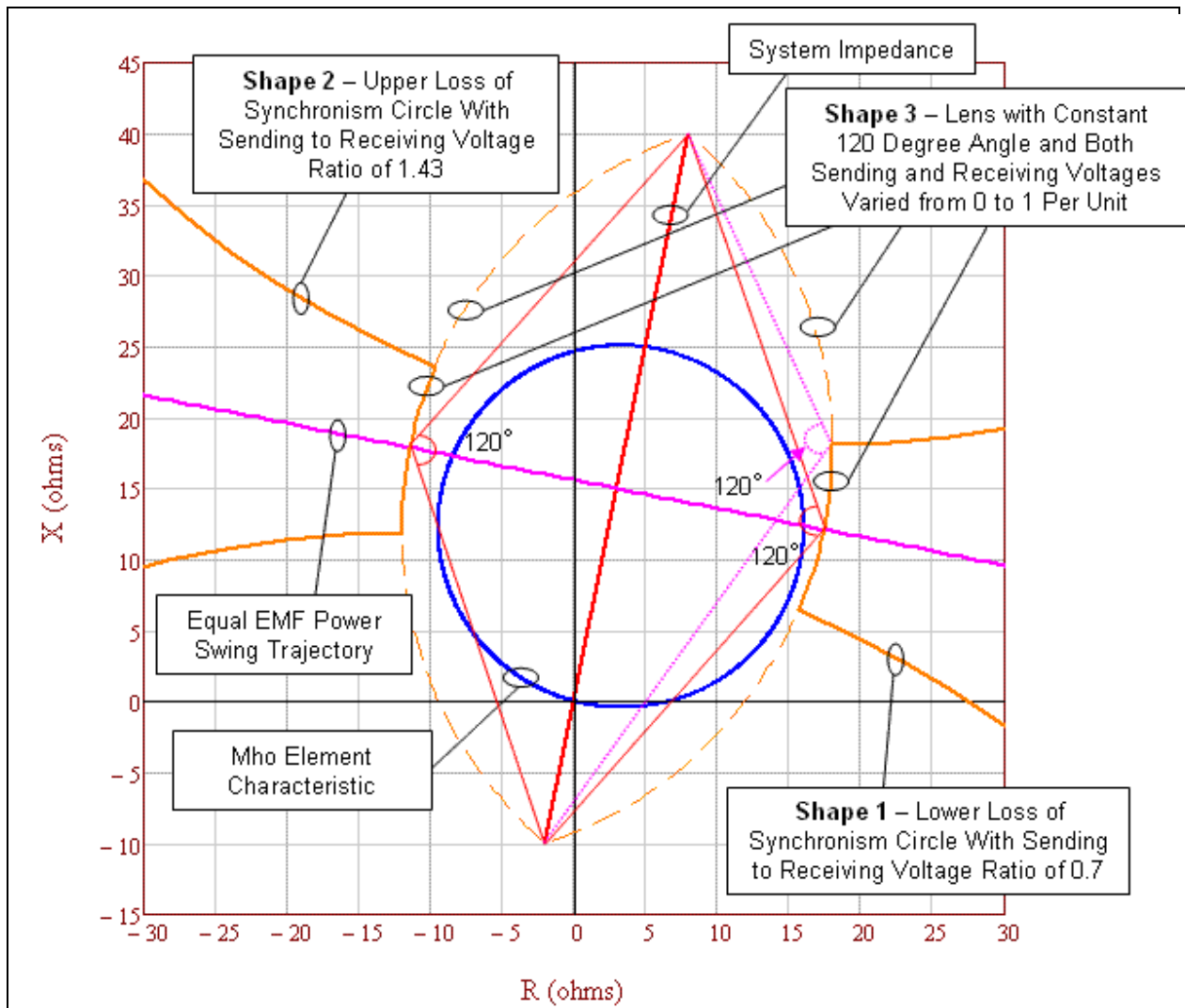
The second bullet of PRC-026-1 – Attachment B, ~~Criteria~~Criterion A, No. 1 evaluates impedance relay elements at a system separation angle of less than 120 degrees, similar to the first bullet described above. An angle less than 120 degrees may be used if a documented stability analysis demonstrates that the power swing becomes unstable at a system separation angle of less than 120 degrees.

The exclusion of relay elements supervised by Power Swing Blocking (PSB) in PRC-026-1 – Attachment A allows the Generator Owner or Transmission Owner to exclude protective relay elements if they are blocked from tripping by PSB relays. A PSB relay applied and set according to industry accepted practices prevent supervised load-responsive protective relays from tripping in response to power swings. Further, PSB relays are set to allow dependable tripping of supervised elements. The criteria in PRC-026-1 – Attachment B specifically applies to unsupervised elements that could trip for stable power swings. Therefore, load-responsive protective relay elements supervised by PSB can be excluded from the Requirements of this standard.

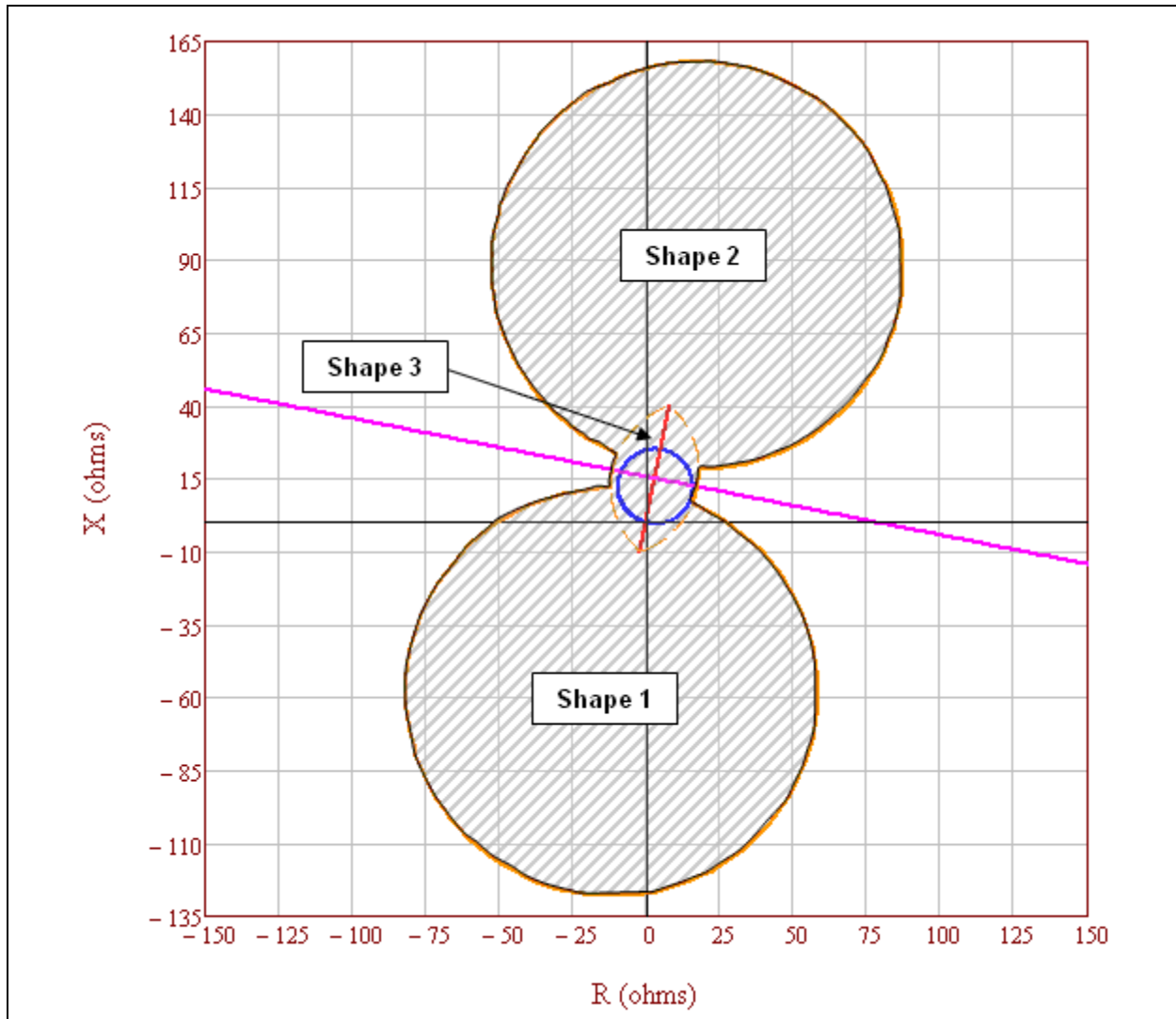
---

<sup>18</sup> “The critical angle for maintaining stability will vary depending on the contingency and the system condition at the time the contingency occurs; however, the likelihood of recovering from a swing that exceeds 120 degrees is marginal and 120 degrees is generally accepted as an appropriate basis for setting out-of-step protection. Given the importance of separating unstable systems, defining 120 degrees as the critical angle is appropriate to achieve a proper balance between dependable tripping for unstable power swings and secure operation for stable power swings.” NERC System Protection and Control Subcommittee, *Protection System Response to Power Swings*, August 2013: [http://www.nerc.com/comm/PC/System%20Protection%20and%20Control%20Subcommittee%20SPCS%202020/SPCS%20Power%20Swing%20Report\\_Final\\_20131015.pdf](http://www.nerc.com/comm/PC/System%20Protection%20and%20Control%20Subcommittee%20SPCS%202020/SPCS%20Power%20Swing%20Report_Final_20131015.pdf), p. 28.

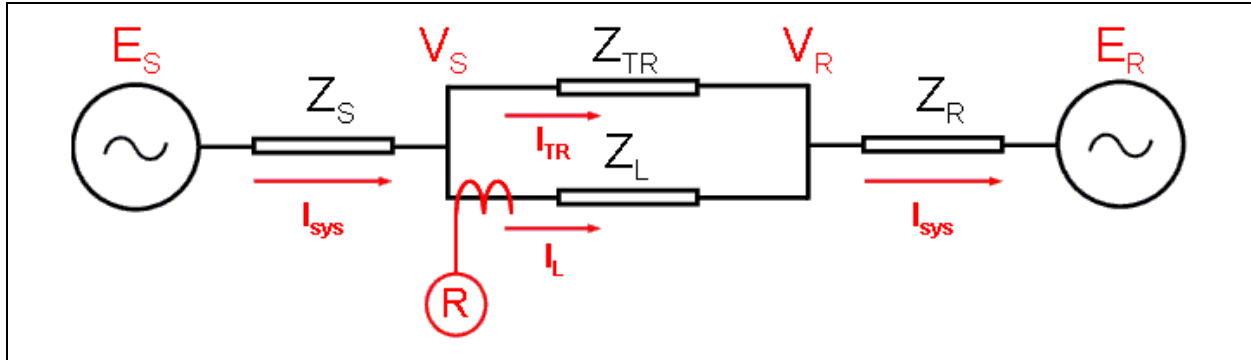




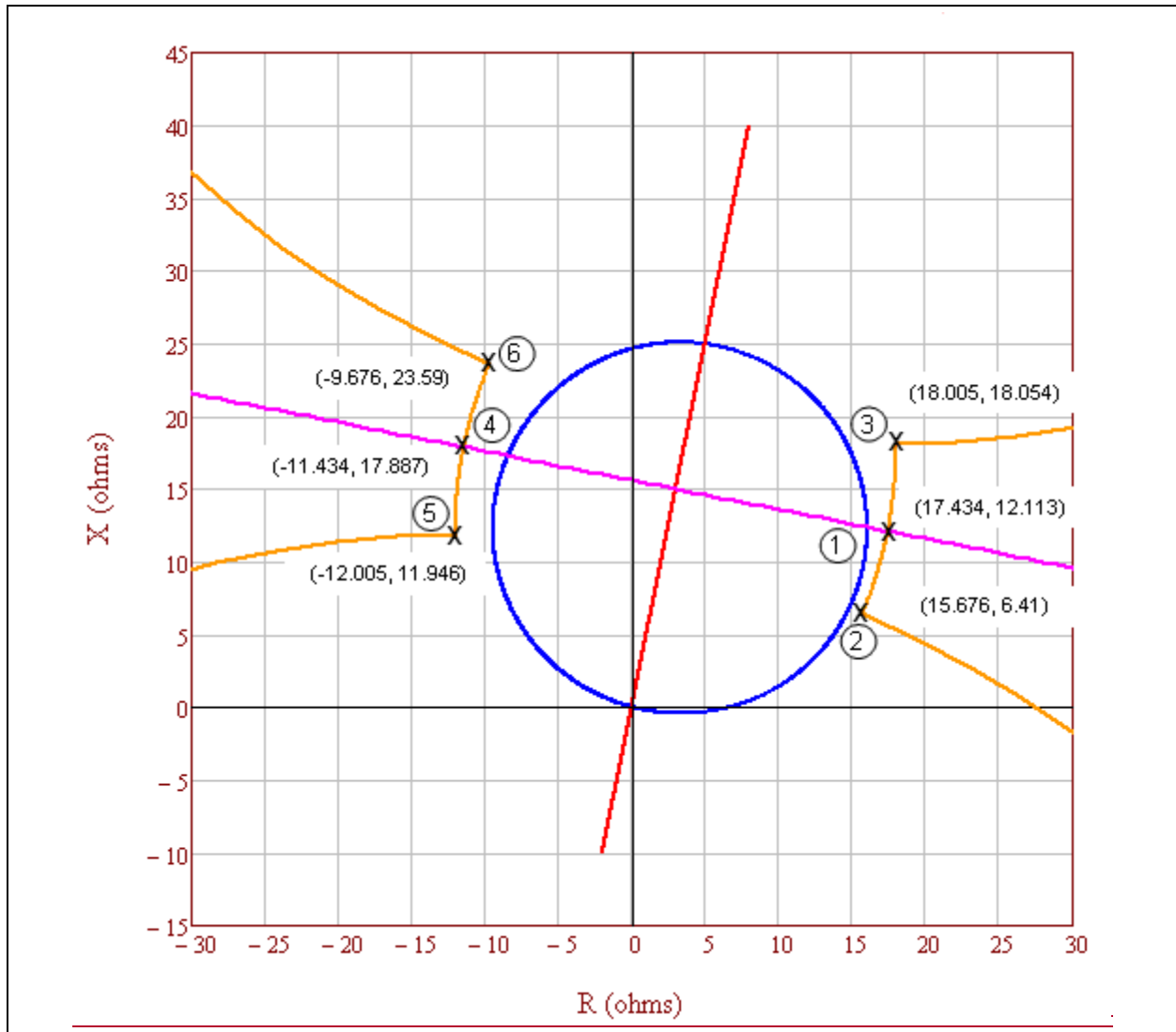
**Figure 1:** An enlarged graphic illustrating the unstable power swing region formed by the union of three shapes in the impedance (R-X) plane: Shape 1) Lower loss-of-synchronism circle, Shape 2) Upper loss-of-synchronism circle, and Shape 3) Lens. The mho element characteristic is completely contained within the unstable power swing region (i.e., it does not intersect any portion of the unstable power swing region), therefore it ~~complies with~~ meets PRC-026-1 – Attachment B, ~~Criteria~~ Criterion A, No. 1.

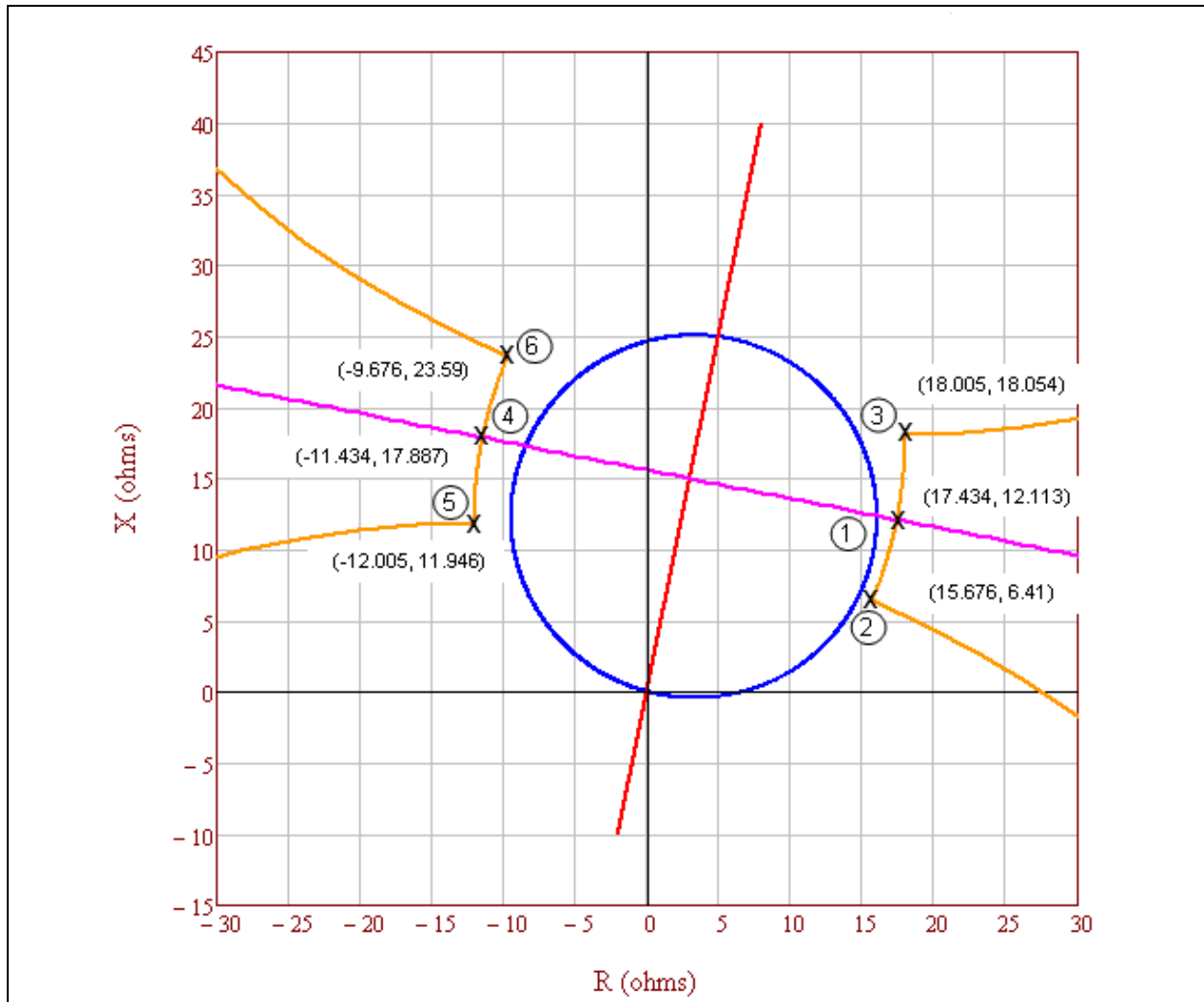


**Figure 2:** Full graphic of the unstable power swing region formed by the union of the three shapes in the impedance (R-X) plane: Shape 1) Lower loss-of-synchronism circle, Shape 2) Upper loss-of-synchronism circle, and Shape 3) Lens. The mho element characteristic is completely contained within the unstable power swing region, therefore it meets PRC-26-1 – Attachment B, Criteria Criterion A, No.1.



**Figure 3.:** System ~~impedance~~ impedances as seen by ~~relay~~ Relay R. (voltage connections are not shown).





**Figure 4.:** The defining unstable power swing region points where the lens shape intersects the lower and upper loss-of-synchronism circle shapes and where the lens intersects the equal EMF (electromotive force) power swing.

**PRC-026-1 – Application Guidelines**

Voltage (p.u.)	Left Side Coordinates		Right Side Coordinates	
	R	+ jX	R	+ jX
<b>0.7</b>	<b>-12.005</b>	<b>11.946</b>	<b>15.676</b>	<b>6.41</b>
0.72	-12.004	12.407	15.852	6.836
0.74	-11.996	12.857	16.018	7.255
0.76	-11.982	13.298	16.175	7.667
0.78	-11.961	13.729	16.321	8.073
0.8	-11.935	14.151	16.459	8.472
0.82	-11.903	14.563	16.589	8.865
0.84	-11.867	14.966	16.71	9.251
0.86	-11.826	15.361	16.824	9.631
0.88	-11.78	15.746	16.93	10.004
0.9	-11.731	16.123	17.03	10.371
0.92	-11.678	16.492	17.123	10.732
0.94	-11.621	16.852	17.209	11.086
0.96	-11.562	17.205	17.29	11.435
0.98	-11.499	17.55	17.364	11.777
<b>1</b>	<b>-11.434</b>	<b>17.887</b>	<b>17.434</b>	<b>12.113</b>
0.98	-11.364	18.223	17.499	12.45
0.96	-11.29	18.565	17.562	12.795
0.94	-11.209	18.914	17.621	13.148
0.92	-11.123	19.268	17.678	13.508
0.9	-11.03	19.629	17.731	13.877
0.88	-10.93	19.996	17.78	14.254
0.86	-10.824	20.369	17.826	14.639
0.84	-10.71	20.749	17.867	15.034
0.82	-10.589	21.135	17.903	15.437
0.8	-10.459	21.528	17.935	15.849
0.78	-10.321	21.927	17.961	16.271
0.76	-10.175	22.333	17.982	16.702
0.74	-10.018	22.745	17.996	17.143
0.72	-9.852	23.164	18.004	17.593
<b>0.7</b>	<b>-9.676</b>	<b>23.59</b>	<b>18.005</b>	<b>18.054</b>



E <sub>S</sub> / E <sub>R</sub> Voltage Ratio	Left Side Coordinates		Right Side Coordinates	
	R	+ jX	R	+ jX
<b>0.7</b>	<b>-12.005</b>	<b>11.946</b>	<b>15.676</b>	<b>6.41</b>
0.72	-12.004	12.407	15.852	6.836
0.74	-11.996	12.857	16.018	7.255
0.76	-11.982	13.298	16.175	7.667
0.78	-11.961	13.729	16.321	8.073
0.8	-11.935	14.151	16.459	8.472
0.82	-11.903	14.563	16.589	8.865
0.84	-11.867	14.966	16.71	9.251
0.86	-11.826	15.361	16.824	9.631
0.88	-11.78	15.746	16.93	10.004
0.9	-11.731	16.123	17.03	10.371
0.92	-11.678	16.492	17.123	10.732
0.94	-11.621	16.852	17.209	11.086
0.96	-11.562	17.205	17.29	11.435
0.98	-11.499	17.55	17.364	11.777
<b>1</b>	<b>-11.434</b>	<b>17.887</b>	<b>17.434</b>	<b>12.113</b>
1.0286	-11.336	18.356	17.524	12.584
1.0572	-11.234	18.81	17.604	13.043
1.0858	-11.127	19.251	17.675	13.49
1.1144	-11.017	19.677	17.738	13.926
1.143	-10.904	20.091	17.792	14.351
1.1716	-10.788	20.491	17.84	14.766
1.2002	-10.67	20.88	17.88	15.17
1.2288	-10.55	21.256	17.914	15.564
1.2574	-10.428	21.621	17.942	15.948
1.286	-10.304	21.975	17.964	16.322
1.3146	-10.18	22.319	17.981	16.687
1.3432	-10.054	22.652	17.993	17.043
1.3718	-9.928	22.976	18.001	17.39
1.4004	-9.801	23.29	18.005	17.728
<b>1.429</b>	<b>-9.676</b>	<b>23.59</b>	<b>18.005</b>	<b>18.054</b>

**Figure 5:** Full table of 31 detailed lens shape point calculations. The bold highlighted rows correspond to the detailed calculations in Tables 2-7.

**Table 2: Example Calculation (Lens Point 1)**

This example is for calculating the impedance the first point of the lens characteristic. Equal source voltages are used for the 230 kV (base) line with the sending-end voltage (E<sub>S</sub>) leading the receiving-end voltage (E<sub>R</sub>) by 120 degrees. See Figures 3 and 4.

Eq. (6)	$E_S = \frac{V_{LL} \angle 120^\circ}{\sqrt{3}}$
---------	--------------------------------------------------

Table 2: Example Calculation (Lens Point 1)			
	$E_S = \frac{230,000 \angle 120^\circ V}{\sqrt{3}}$		
	$E_S = 132,791 \angle 120^\circ V$		
Eq. (7)	$E_R = \frac{V_{LL} \angle 0^\circ}{\sqrt{3}}$		
	$E_R = \frac{230,000 \angle 0^\circ V}{\sqrt{3}}$		
	$E_R = 132,791 \angle 0^\circ V$		
Given <del>positive</del> <b>Positive</b> sequence impedance data ( <del>The</del> <b>with</b> transfer impedance $Z_{TR}$ <del>is</del> set to <b>infinity</b> <del>a large value</del> ).			
Given:	$Z_S = 2 + j10 \Omega$	$Z_L = 4 + j20 \Omega$	$Z_R = 4 + j20 \Omega$
Given:	$Z_{TR} = Z_L \times 10^{10} \Omega$		
Total impedance between <b>the</b> generators.			
Eq. (8)	$Z_{total} = \frac{(Z_L \times Z_{TR})}{(Z_L + Z_{TR})}$		
	$Z_{total} = \frac{((4 + j20) \Omega \times (4 + j20)^{10} \Omega)}{((4 + j20) \Omega + (4 + j20)^{10} \Omega)} = \frac{((4 + j20) \Omega \times (4 + j20) \times 10^{10} \Omega)}{((4 + j20) \Omega + (4 + j20) \times 10^{10} \Omega)}$		
	$Z_{total} = 4 + j20 \Omega$		
Total system impedance.			
Eq. (9)	$Z_{sys} = Z_S + Z_{total} + Z_R$		
	$Z_{sys} = (2 + j10) \Omega + (4 + j20) \Omega + (4 + j20) \Omega$		
	$Z_{sys} = 10 + j50 \Omega$		
Total system current from sending-end source.			
Eq. (10)	$I_{sys} = \frac{E_S - E_R}{Z_{sys}}$		
	$I_{sys} = \frac{132,791 \angle 120^\circ V - 132,791 \angle 0^\circ V}{(10 + j50) \Omega}$		
	$I_{sys} = 4,511 \angle 71.3^\circ A$		
The current, as measured by the relay on $Z_L$ ( <b>Figure 3</b> ), is only the current flowing through that line as determined by using the current divider equation.			
Eq. (11)	$I_L = I_{sys} \times \frac{Z_{TR}}{Z_L + Z_{TR}}$		

**Table 2: Example Calculation (Lens Point 1)**

	$I_L = 4,511 \angle 71.3^\circ A$ $\times \frac{(4 + j20)^{10} \Omega}{(4 + j20) \Omega + (4 + j20)^{10} \Omega} \frac{(4 + j20) \times 10^{10} \Omega}{(4 + j20) \Omega + (4 + j20) \times 10^{10} \Omega}$
	$I_L = 4,511 \angle 71.3^\circ A$
<p>The voltage, as measured by the relay on <math>Z_L</math> (Figure 3), is the voltage drop from the sending-end source through the sending-end source impedance.</p>	
Eq. (12)	$V_S = E_S - (Z_S \times I_{sys})$
	$V_S = 132,791 \angle 120^\circ V - [(2 + j10) \Omega \times 4,511 \angle 71.3^\circ A]$
	$V_S = 95,757 \angle 106.1^\circ V$
<p>The impedance seen by the relay on <math>Z_L</math>.</p>	
Eq. (13)	$Z_{L-Relay} = \frac{V_S}{I_L}$
	$Z_{L-Relay} = \frac{95,757 \angle 106.1^\circ V}{4,511 \angle 71.3^\circ A}$
	$Z_{L-Relay} = 17.434 + j12.113 \Omega$

**Table 3: Example Calculation (Lens Point 2)**

<p>This example is for calculating the impedance second point of the lens characteristic. Unequal source voltages are used for the 230 kV (base) line with the sending-end voltage (<math>E_S</math>) at 70% of the receiving-end voltage (<math>E_R</math>) and leading the receiving-end voltage by 120 degrees. See Figures 3 and 4.</p>	
Eq. (14)	$E_S = \frac{V_{LL} \angle 120^\circ}{\sqrt{3}} \times 70\%$
	$E_S = \frac{230,000 \angle 120^\circ V}{\sqrt{3}} \times 0.70$
	$E_S = 92,953.7 \angle 120^\circ V$
Eq. (15)	$E_R = \frac{V_{LL} \angle 0^\circ}{\sqrt{3}}$
	$E_R = \frac{230,000 \angle 0^\circ V}{\sqrt{3}}$
	$E_R = 132,791 \angle 0^\circ V$

Table 3: Example Calculation (Lens Point 2)			
Given <del>positive</del> Positive sequence impedance data ( <del>The</del> with transfer impedance $Z_{TR}$ <del>is</del> set to <del>infinity</del> a large value).			
Given:	$Z_S = 2 + j10 \Omega$	$Z_L = 4 + j20 \Omega$	$Z_R = 4 + j20 \Omega$
Given:	$Z_{TR} = Z_L \times 10^{10} \Omega$		
Total impedance between <del>the</del> generators.			
Eq. (16)	$Z_{total} = \frac{(Z_L \times Z_{TR})}{(Z_L + Z_{TR})}$		
	$Z_{total} = \frac{\cancel{(4 + j20) \Omega} \times \cancel{(4 + j20)^{10} \Omega} ((4 + j20) \Omega \times (4 + j20) \times 10^{10} \Omega)}{\cancel{(4 + j20) \Omega} + \cancel{(4 + j20)^{10} \Omega} ((4 + j20) \Omega + (4 + j20) \times 10^{10} \Omega)}$		
	$Z_{total} = 4 + j20 \Omega$		
Total system impedance.			
Eq. (17)	$Z_{sys} = Z_S + Z_{total} + Z_R$		
	$Z_{sys} = (2 + j10) \Omega + (4 + j20) \Omega + (4 + j20) \Omega$		
	$Z_{sys} = 10 + j50 \Omega$		
Total system current from sending-end source.			
Eq. (18)	$I_{sys} = \frac{E_S - E_R}{Z_{sys}}$		
	$I_{sys} = \frac{92,953.7 \angle 120^\circ V - 132,791 \angle 0^\circ V}{(10 + j50) \Omega}$		
	$I_{sys} = 3,854 \angle 77^\circ A$		
The current, $I_L$ , as measured by the relay on $Z_L$ (Figure 3), is only the current flowing through that line as determined by using the current divider equation.			
Eq. (19)	$I_L = I_{sys} \times \frac{Z_{TR}}{Z_L + Z_{TR}}$		
	$I_L = 3,854 \angle 77^\circ A \times \frac{\cancel{(4 + j20)^{10} \Omega} (4 + j20) \times 10^{10} \Omega}{\cancel{(4 + j20) \Omega} + \cancel{(4 + j20)^{10} \Omega} (4 + j20) \Omega + (4 + j20) \times 10^{10} \Omega}$		
	$I_L = 3,854 \angle 77^\circ A$		
The voltage, $V_S$ , as measured by the relay on $Z_L$ (Figure 3), is the voltage drop from the sending-end source through the sending-end source impedance.			
Eq. (20)	$V_S = E_S - (Z_S \times I_{sys})$		
	$V_S = 92,953 \angle 120^\circ V - [(2 + j10) \Omega \times 3,854 \angle 77^\circ A]$		

Table 3: Example Calculation (Lens Point 2)	
	$V_S = 65,271 \angle 99^\circ V$
The impedance seen by the relay on $Z_L$ .	
Eq. (21)	$Z_{L-Relay} = \frac{V_S}{I_L}$
	$Z_{L-Relay} = \frac{65,271 \angle 99^\circ V}{3,854 \angle 77^\circ A}$
	$Z_{L-Relay} = 15.676 + j6.41 \Omega$

Table 4: Example Calculation (Lens Point 3)	
This example is for calculating the impedance third point of the lens characteristic. Unequal source voltages are used for the 230 kV (base) line with the receiving-end voltage ( $E_R$ ) at 70% of the sending-end voltage ( $E_S$ ) and the sending-end voltage leading the receiving-end voltage by 120 degrees. See Figures 3 and 4.	
Eq. (22)	$E_S = \frac{V_{LL} \angle 120^\circ}{\sqrt{3}}$
	$E_S = \frac{230,000 \angle 120^\circ V}{\sqrt{3}}$
	$E_S = 132,791 \angle 120^\circ V$
Eq. (23)	$E_R = \frac{V_{LL} \angle 0^\circ}{\sqrt{3}} \times 70\%$
	$E_R = \frac{230,000 \angle 0^\circ V}{\sqrt{3}} \times 0.70$
	$E_R = 92,953.7 \angle 0^\circ V$
<del>Given positive</del> Positive sequence impedance data ( <del>The</del> with transfer impedance $Z_{TR}$ <del>is</del> set to <del>infinity</del> a large value).	
Given:	$Z_S = 2 + j10 \Omega$ $Z_L = 4 + j20 \Omega$ $Z_R = 4 + j20 \Omega$
Given:	$Z_{TR} = Z_L \times 10^{10} \Omega$
Total impedance between <del>the</del> generators.	
Eq. (24)	$Z_{total} = \frac{(Z_L \times Z_{TR})}{(Z_L + Z_{TR})}$
	$Z_{total} = \frac{((4 + j20) \Omega \times (4 + j20)^{10} \Omega)}{((4 + j20) \Omega + (4 + j20)^{10} \Omega)} \frac{((4 + j20) \Omega \times (4 + j20) \times 10^{10} \Omega)}{((4 + j20) \Omega + (4 + j20) \times 10^{10} \Omega)}$
	$Z_{total} = 4 + j20 \Omega$

Table 4: Example Calculation (Lens Point 3)	
Total system impedance.	
Eq. (25)	$Z_{sys} = Z_S + Z_{total} + Z_R$
	$Z_{sys} = (2 + j10) \Omega + (4 + j20) \Omega + (4 + j20) \Omega$
	$Z_{sys} = 10 + j50 \Omega$
Total system current from sending-end source.	
Eq. (26)	$I_{sys} = \frac{E_S - E_R}{Z_{sys}}$
	$I_{sys} = \frac{132,791 \angle 120^\circ V - 92,953.7 \angle 0^\circ V}{(10 + j50) \Omega}$
	$I_{sys} = 3,854 \angle 65.5^\circ A$
The current, as measured by the relay on $Z_L$ (Figure 3), is only the current flowing through that line as determined by using the current divider equation.	
Eq. (27)	$I_L = I_{sys} \times \frac{Z_{TR}}{Z_L + Z_{TR}}$
	$I_L = 3,854 \angle 65.5^\circ A$ $\times \frac{(4 + j20) \times 10^{10} \Omega}{(4 + j20) \Omega + (4 + j20) \times 10^{10} \Omega} \frac{(4 + j20) \times 10^{10} \Omega}{(4 + j20) \Omega + (4 + j20) \times 10^{10} \Omega}$
	$I_L = 3,854 \angle 65.5^\circ A$
The voltage, as measured by the relay on $Z_L$ (Figure 3), is the voltage drop from the sending-end source through the sending-end source impedance.	
Eq. (28)	$V_S = E_S - (Z_S \times I_L)$
	$V_S = 132,791 \angle 120^\circ V - [(2 + j10) \Omega \times 3,854 \angle 65.5^\circ A]$
	$V_S = 98,265 \angle 110.6^\circ V$
The impedance seen by the relay on $Z_L$ .	
Eq. (29)	$Z_{L-Relay} = \frac{V_S}{I_L}$
	$Z_{L-Relay} = \frac{98,265 \angle 110.6^\circ V}{3,854 \angle 65.5^\circ A}$
	$Z_{L-Relay} = 18.005 + j18.054 \Omega$

**Table 5: Example Calculation (Lens Point 4)**

This example is for calculating the impedance fourth point of the lens characteristic. Equal source voltages are used for the 230 kV (base) line with the sending-end voltage ( $E_S$ ) leading the receiving-end voltage ( $E_R$ ) by 240 degrees. See Figures 3 and 4.

Eq. (30)	$E_S = \frac{V_{LL} \angle 240^\circ}{\sqrt{3}}$
	$E_S = \frac{230,000 \angle 240^\circ V}{\sqrt{3}}$
	$E_S = 132,791 \angle 240^\circ V$
Eq. (31)	$E_R = \frac{V_{LL} \angle 0^\circ}{\sqrt{3}}$
	$E_R = \frac{230,000 \angle 0^\circ V}{\sqrt{3}}$
	$E_R = 132,791 \angle 0^\circ V$
<p><del>Given positive</del> Positive sequence impedance data (<del>The</del>with transfer impedance <math>Z_{TR}</math> <del>is</del> set to <del>infinity</del> a large value).</p>	
Given:	$Z_S = 2 + j10 \Omega$ $Z_L = 4 + j20 \Omega$ $Z_R = 4 + j20 \Omega$
Given:	$Z_{TR} = Z_L \times 10^{10} \Omega$
Total impedance between <del>the</del> generators.	
Eq. (32)	$Z_{total} = \frac{(Z_L \times Z_{TR})}{(Z_L + Z_{TR})}$
	$Z_{total} = \frac{\cancel{(4 + j20) \Omega} \times \cancel{(4 + j20)^{10} \Omega}}{\cancel{(4 + j20) \Omega} + \cancel{(4 + j20)^{10} \Omega}} \frac{((4 + j20) \Omega \times (4 + j20) \times 10^{10} \Omega)}{((4 + j20) \Omega + (4 + j20) \times 10^{10} \Omega)}$
	$Z_{total} = 4 + j20 \Omega$
Total system impedance.	
Eq. (33)	$Z_{sys} = Z_S + Z_{total} + Z_R$
	$Z_{sys} = (2 + j10) \Omega + (4 + j20) \Omega + (4 + j20) \Omega$
	$Z_{sys} = 10 + j50 \Omega$
Total system current from sending-end source.	
Eq. (34)	$I_{sys} = \frac{E_S - E_R}{Z_{sys}}$
	$I_{sys} = \frac{132,791 \angle 240^\circ V - 132,791 \angle 0^\circ V}{(10 + j50) \Omega}$
	$I_{sys} = 4,510511 \angle 131.3^\circ A$

**Table 5: Example Calculation (Lens Point 4)**

The current, $I_L$ , as measured by the relay on $Z_L$ (Figure 3), is only the current flowing through that line as determined by using the current divider equation.	
Eq. (35)	$I_L = I_{sys} \times \frac{Z_{TR}}{Z_L + Z_{TR}}$
	$I_L = 4,510,511 \angle 131.1^\circ A \times \frac{(4 + j20) \times 10^{10} \Omega}{(4 + j20) \Omega + (4 + j20) \times 10^{10} \Omega}$
	$I_L = 4,510,511 \angle 131.1^\circ A$
The voltage, $V_S$ , as measured by the relay on $Z_L$ (Figure 3), is the voltage drop from the sending-end source through the sending-end source impedance.	
Eq. (36)	$V_S = E_S - (Z_S \times I_L)$
	$V_S = 132,791 \angle 240^\circ V - [(2 + j10) \Omega \times 4,510 \angle 131.1^\circ A] + [(2 + j10) \Omega \times 4,511 \angle 131.1^\circ A]$
	$V_S = 95,756 \angle -106.1^\circ V$
The impedance seen by the relay on $Z_L$ .	
Eq. (37)	$Z_{L-Relay} = \frac{V_S}{I_L}$
	$Z_{L-Relay} = \frac{95,756 \angle -106.1^\circ V}{4,510 \angle 131.1^\circ A} = \frac{95,756 \angle -106.1^\circ V}{4,511 \angle 131.1^\circ A}$
	$Z_{L-Relay} = -11.434 + j17.887 \Omega$

**Table 6: Example Calculation (Lens Point 5)**

This example is for calculating the impedance fifth point of the lens characteristic. Unequal source voltages are used for the 230 kV (base) line with the sending-end voltage ( $E_S$ ) at 70% of the receiving-end voltage ( $E_R$ ) and leading the receiving-end voltage by 240 degrees. See Figures 3 and 4.	
Eq. (38)	$E_S = \frac{V_{LL} \angle 240^\circ}{\sqrt{3}} \times 70\%$
	$E_S = \frac{230,000 \angle 240^\circ V}{\sqrt{3}} \times 0.70$
	$E_S = 92,953.7 \angle 240^\circ V$
Eq. (39)	$E_R = \frac{V_{LL} \angle 0^\circ}{\sqrt{3}}$



Table 6: Example Calculation (Lens Point 5)			
	$E_R = \frac{230,000 \angle 0^\circ V}{\sqrt{3}}$		
	$E_R = 132,791 \angle 0^\circ V$		
Given <del>positive</del> Positive sequence impedance data ( <del>The</del> with transfer impedance $Z_{TR}$ <del>is</del> -set to <del>infinity</del> a large value).			
Given:	$Z_S = 2 + j10 \Omega$	$Z_L = 4 + j20 \Omega$	$Z_R = 4 + j20 \Omega$
Given:	$Z_{TR} = Z_L \times 10^{10} \Omega$		
Total impedance between <del>the</del> generators.			
Eq. (40)	$Z_{total} = \frac{(Z_L \times Z_{TR})}{(Z_L + Z_{TR})}$		
	$Z_{total} = \frac{((4 + j20) \Omega \times (4 + j20)^{10} \Omega) ((4 + j20) \Omega \times (4 + j20) \times 10^{10} \Omega)}{((4 + j20) \Omega + (4 + j20)^{10} \Omega) ((4 + j20) \Omega + (4 + j20) \times 10^{10} \Omega)}$		
	$Z_{total} = 4 + j20 \Omega$		
Total system impedance.			
Eq. (41)	$Z_{sys} = Z_S + Z_{total} + Z_R$		
	$Z_{sys} = (2 + j10 \Omega) + (4 + j20 \Omega) + (4 + j20 \Omega)$		
	$Z_{sys} = 10 + j50 \Omega$		
Total system current from sending-end source.			
Eq. (42)	$I_{sys} = \frac{E_S - E_R}{Z_{sys}}$		
	$I_{sys} = \frac{92,953.7 \angle 240^\circ V - 132,791 \angle 0^\circ V}{10 + j50 \Omega}$		
	$I_{sys} = 3,854 \angle 125.5^\circ A$		
The current, $I_L$ , as measured by the relay on $Z_L$ (Figure 3), is only the current flowing through that line as determined by using the current divider equation.			
Eq. (43)	$I_L = I_{sys} \times \frac{Z_{TR}}{Z_L + Z_{TR}}$		
	$I_L = 3,854 \angle 125.5^\circ A$		
	$\times \frac{(4 + j20)^{10} \Omega}{(4 + j20) \Omega + (4 + j20)^{10} \Omega} \frac{(4 + j20) \times 10^{10} \Omega}{(4 + j20) \Omega + (4 + j20) \times 10^{10} \Omega}$		
	$I_L = 3,854 \angle 125.5^\circ A$		

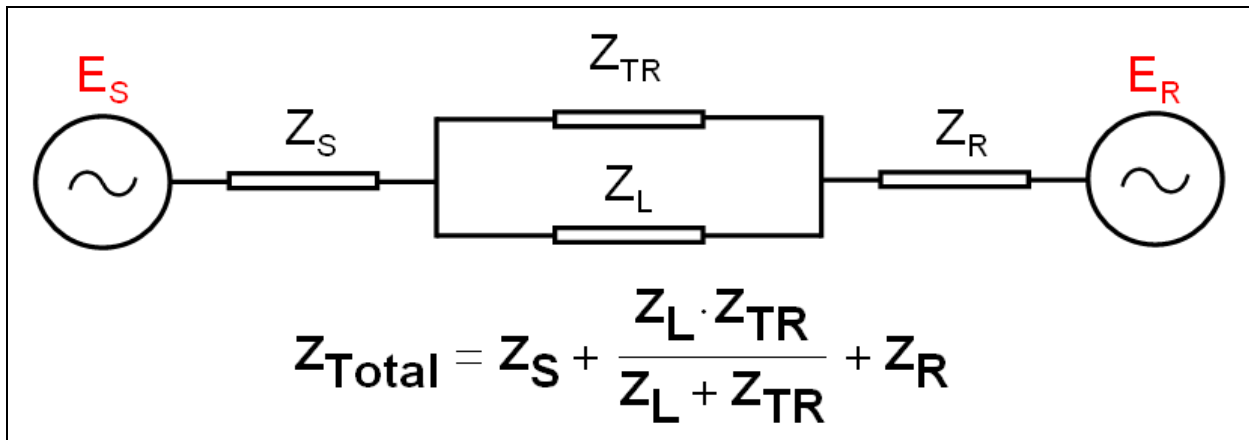
**Table 6: Example Calculation (Lens Point 5)**

The voltage, as measured by the relay on $Z_L$ (Figure 3), is the voltage drop from the sending-end source through the sending-end source impedance.	
Eq. (44)	$V_S = E_S - (Z_S \times I_L)$
	$V_S = 92,953.7 \angle 240^\circ V - [(2 + j10) \Omega \times 3,854 \angle 125.5^\circ A]$
	$V_S = 65,270.5 \angle -99.4^\circ V$
The impedance seen by the relay on $Z_L$ .	
Eq. (45)	$Z_{L-Relay} = \frac{V_S}{I_L}$
	$Z_{L-Relay} = \frac{65,270.5 \angle -99.4^\circ V}{3,854 \angle 125.5^\circ A}$
	$Z_{L-Relay} = -12.005 + j11.946 \Omega$

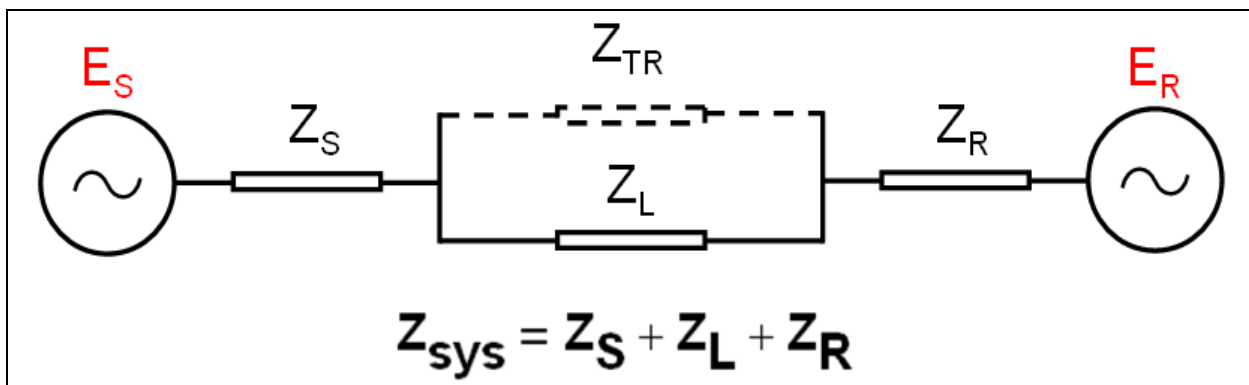
**Table 7: Example Calculation (Lens Point 6)**

This example is for calculating the impedance sixth point of the lens characteristic. Unequal source voltages are used for the 230 kV (base) line with the receiving-end voltage ( $E_R$ ) at 70% of the sending-end voltage ( $E_S$ ) and the sending-end voltage leading the receiving-end voltage by 240 degrees. See Figures 3 and 4.	
Eq. (46)	$E_S = \frac{V_{LL} \angle 240^\circ}{\sqrt{3}}$
	$E_S = \frac{230,000 \angle 240^\circ V}{\sqrt{3}}$
	$E_S = 132,791 \angle 240^\circ V$
Eq. (47)	$E_R = \frac{V_{LL} \angle 0^\circ}{\sqrt{3}} \times 70\%$
	$E_R = \frac{230,000 \angle 0^\circ V}{\sqrt{3}} \times 0.70$
	$E_R = 92,953.7 \angle 0^\circ V$
<del>Given positive</del> Positive sequence impedance data ( <del>The</del> with transfer impedance $Z_{TR}$ <del>is</del> -set to <del>infinity</del> a large value).	
Given:	$Z_S = 2 + j10 \Omega$ $Z_L = 4 + j20 \Omega$ $Z_R = 4 + j20 \Omega$
Given:	$Z_{TR} = Z_L \times 10^{10} \Omega$
Total impedance between <del>the</del> generators.	
Eq. (48)	$Z_{total} = \frac{(Z_L \times Z_{TR})}{(Z_L + Z_{TR})}$

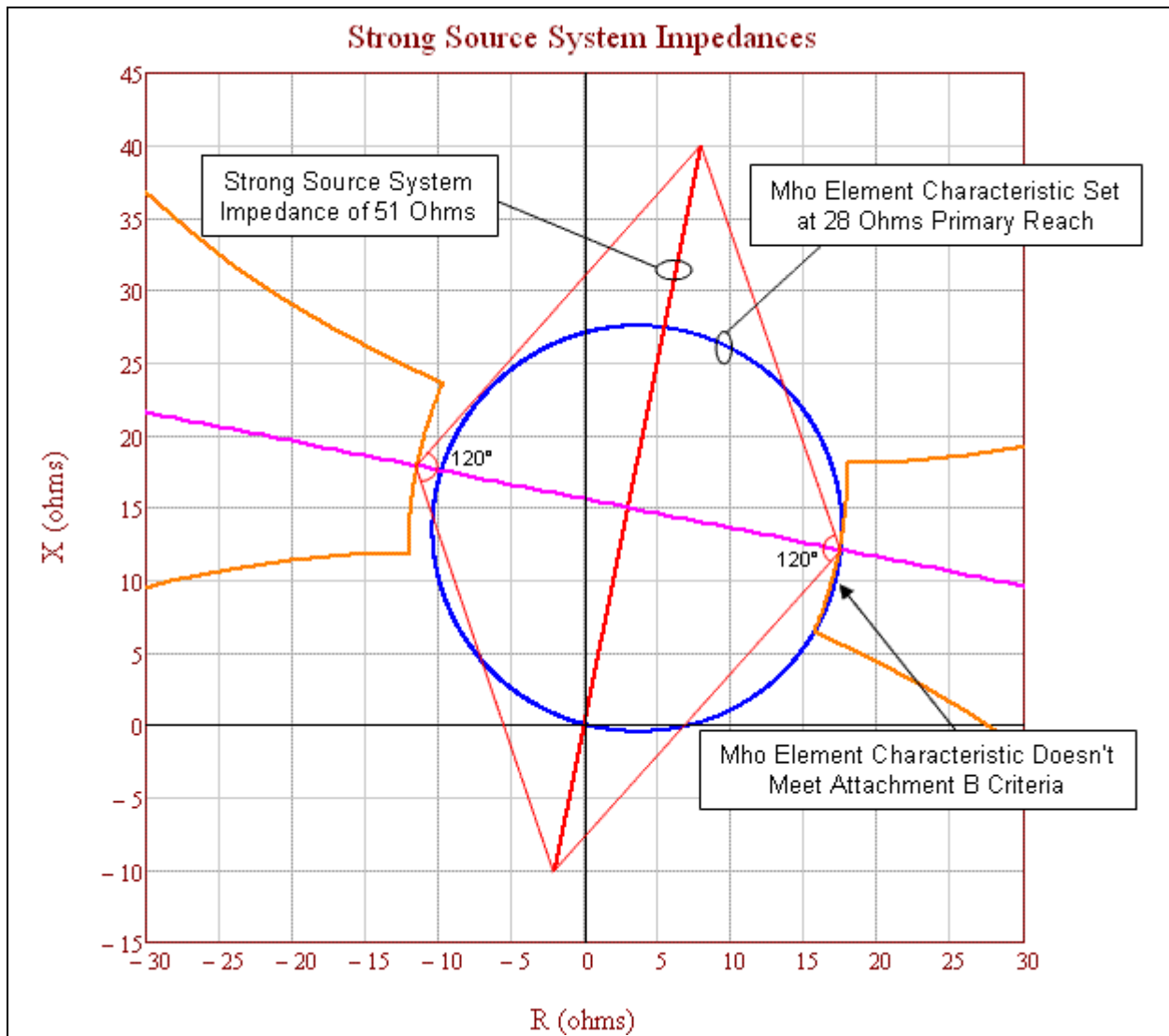
Table 7: Example Calculation (Lens Point 6)	
	$Z_{total} = \frac{((4 + j20) \Omega \times (4 + j20)^{10} \Omega) ((4 + j20) \Omega \times (4 + j20) \times 10^{10} \Omega)}{((4 + j20) \Omega + (4 + j20)^{10} \Omega) ((4 + j20) \Omega + (4 + j20) \times 10^{10} \Omega)}$
	$Z_{total} = 4 + j20 \Omega$
Total system impedance.	
Eq. (49)	$Z_{sys} = Z_S + Z_{total} + Z_R$
	$Z_{sys} = (2 + j10) \Omega + (4 + j20) \Omega + (4 + j20) \Omega$
	$Z_{sys} = 10 + j50 \Omega$
Total system current from sending-end source.	
Eq. (50)	$I_{sys} = \frac{E_S - E_R}{Z_{sys}}$
	$I_{sys} = \frac{132,791 \angle 240^\circ V - 92,953.7 \angle 0^\circ V}{10 + j50 \Omega}$
	$I_{sys} = 3,854 \angle 137.1^\circ A$
The current, $I_L$ , as measured by the relay on $Z_L$ (Figure 3), is only the current flowing through that line as determined by using the current divider equation.	
Eq. (51)	$I_L = I_{sys} \times \frac{Z_{TR}}{Z_L + Z_{TR}}$
	$I_L = 3,854 \angle 137.1^\circ A$ $\times \frac{(4 + j20)^{10} \Omega}{(4 + j20) \Omega + (4 + j20)^{10} \Omega} \frac{(4 + j20) \times 10^{10} \Omega}{(4 + j20) \Omega + (4 + j20) \times 10^{10} \Omega}$
	$I_L = 3,854 \angle 137.1^\circ A$
The voltage, $V_S$ , as measured by the relay on $Z_L$ (Figure 3), is the voltage drop from the sending-end source through the sending-end source impedance.	
Eq. (52)	$V_S = E_S - (Z_S \times I_L)$
	$V_S = 132,791 \angle 240^\circ V$ $- [(2 + j10) \Omega \times 3,854 \angle 137.1^\circ A] [(2 + j10) \Omega \times 3,854 \angle 137.1^\circ A]$
	$V_S = 98,265 \angle -110.6^\circ V$
The impedance seen by the relay on $Z_L$ .	
Eq. (53)	$Z_{L-Relay} = \frac{V_S}{I_L}$
	$Z_{L-Relay} = \frac{98,265 \angle -110.6^\circ V}{3,854 \angle 137.1^\circ A}$
	$Z_{L-Relay} = -9.676 + j23.59 \Omega$



**Figure 6:** Reduced two bus system with sending-end source impedance  $Z_S$ , receiving-end source impedance  $Z_R$ , line impedance  $Z_L$ , and parallel transfer impedance  $Z_{\text{TR}}$ .

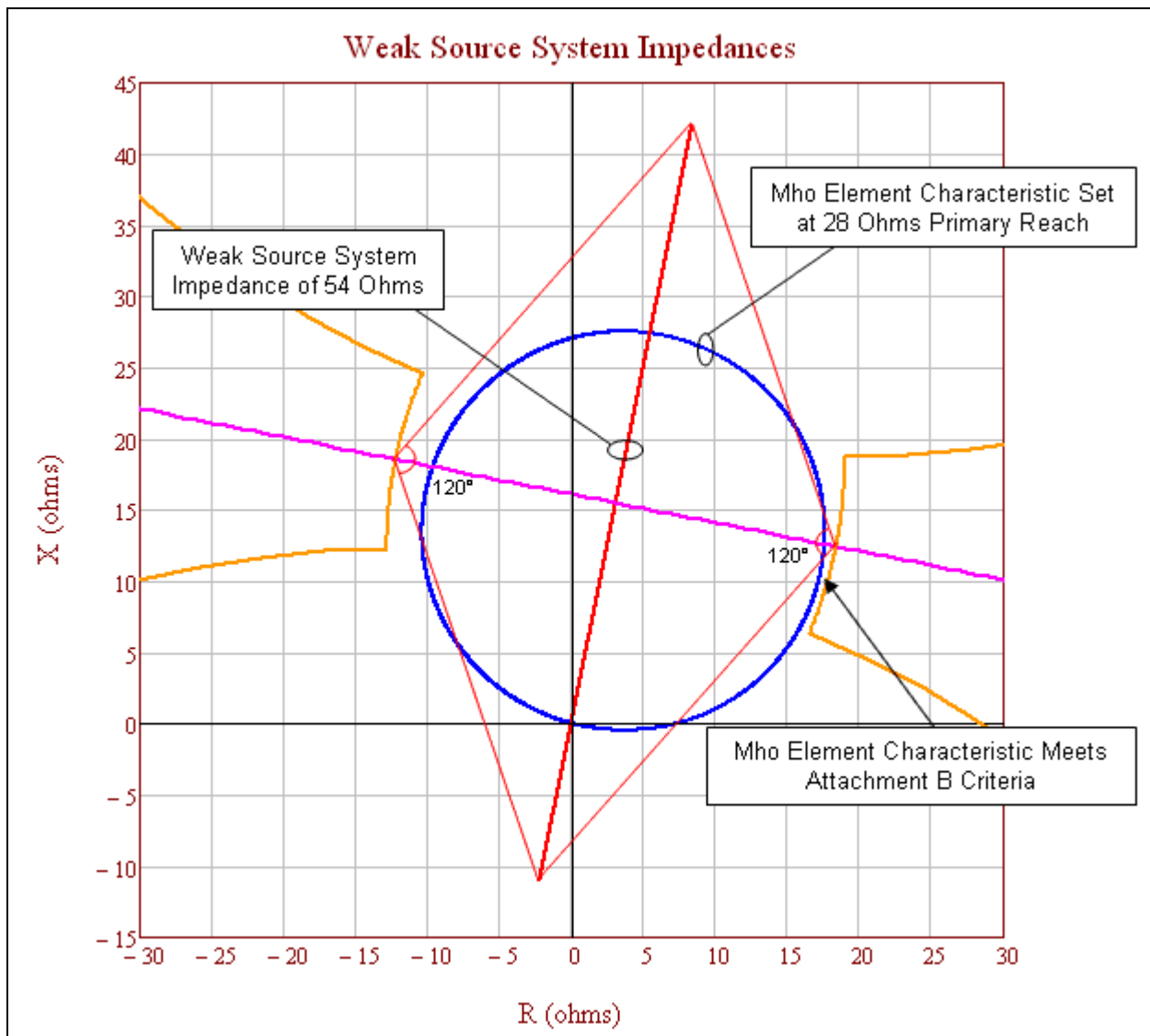


**Figure 7:** Reduced two bus system with sending-end source impedance  $Z_S$ , receiving-end source impedance  $Z_R$ , and line impedance  $Z_L$ , and with the parallel transfer impedance  $Z_{\text{TR}}$  removed.



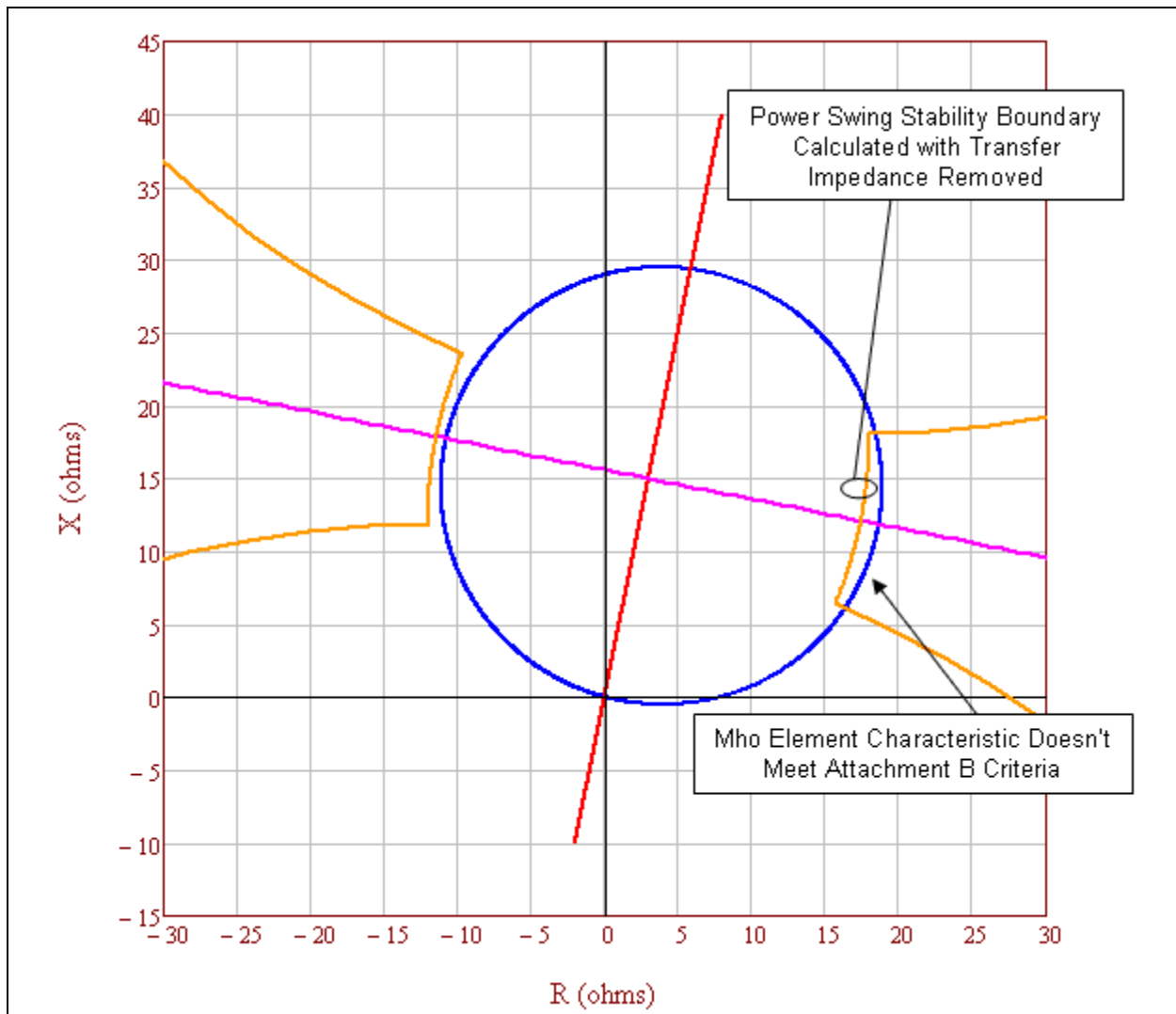
**Figure 8:** A strong-source system with a line impedance of  $Z_L = 20.4$  ohms (i.e., the thicker red line). This mho element characteristic (i.e., the blue circle) does not meet the PRC-026-1 – Attachment B, Criteria Criterion A because it is not completely contained within the unstable power swing region (i.e., the orange characteristic).

The figure Figure 8 above represents a heavily-heavily-loaded system using a maximum with all generation profile in service and all transmission BES Elements in their normal operating state. The mho element characteristic (set at 137% of  $Z_L$ ) extends into the unstable power swing region (i.e., the orange characteristic). Using the strongest source system is more conservative because it shrinks the unstable power swing region, bringing it closer to the mho element characteristic. This figure also graphically represents the effect of a system strengthening over time and this is the reason for re-evaluation if the relay has not been evaluated in the last five calendar years. Figure 9 below depicts a relay that meets the PRC-026-1 – Attachment B, Criteria Criterion A. Figure 8 depicts the same relay with the same setting five years later, where each source has strengthened by about 10% and now the same mho element characteristic does not meet Criteria Criterion A.



**Figure 9:** A weak-source system with a line impedance of  $Z_L = 20.4$  ohms (i.e., the thicker red line). This mho element characteristic (i.e., the blue circle) meets the PRC-026-1 – Attachment B, Criteria Criterion A because it is completely contained within the unstable power swing region (i.e., the orange characteristic).

The figure Figure 9 above represents a lightly-loaded system, using a minimum generation profile. The mho element characteristic (set at 137% of  $Z_L$ ) does not extend into the unstable power swing region (i.e., the orange characteristic). Using a weaker source system expands the unstable power swing region away from the mho element characteristic.



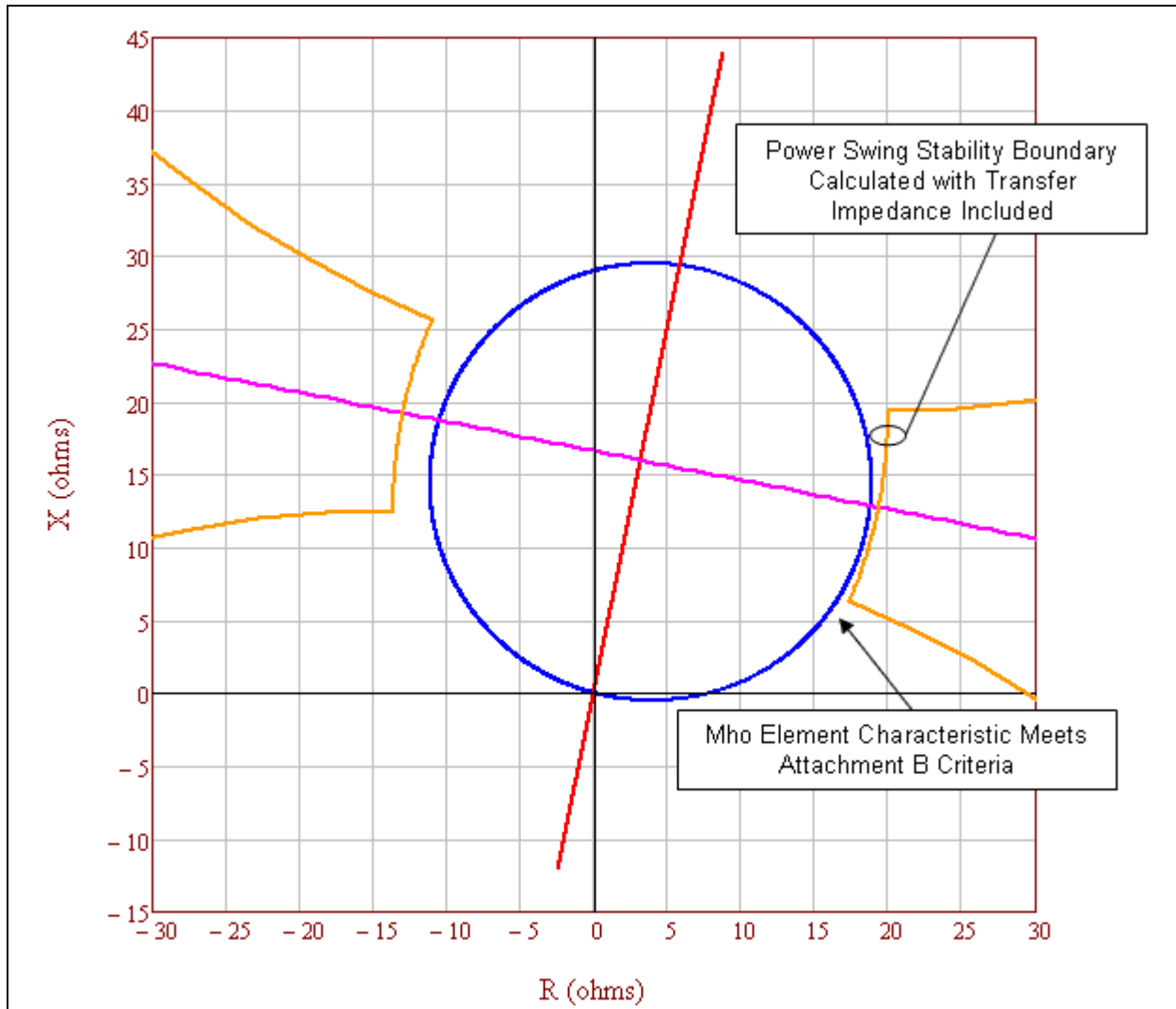
**Figure 10:** This is an example of an unstable power swing region (i.e., the orange characteristic) with the parallel transfer impedance removed. This relay mho element characteristic (i.e., the blue circle) does not meet PRC-026-1 – Attachment B, CriteriaCriterion A because it is not completely contained within the unstable power swing region.

Table 8 : Example Calculation ( <u>Parallel</u> Transfer Impedance Removed)	
Calculations for the point at 120 degrees with equal source impedances. The total system current equals the line current. See Figure 10.	
Eq. (54)	$E_S = \frac{V_{LL} \angle 120^\circ}{\sqrt{3}}$
	$E_S = \frac{230,000 \angle 120^\circ V}{\sqrt{3}}$
	$E_S = 132,791 \angle 120^\circ V$

Table 8: Example Calculation ( <del>Parallel</del> Transfer Impedance Removed)			
Eq. (55)	$E_R = \frac{V_{LL} \angle 0^\circ}{\sqrt{3}}$		
	$E_R = \frac{230,000 \angle 0^\circ V}{\sqrt{3}}$		
	$E_R = 132,791 \angle 0^\circ V$		
Given impedance data.			
Given:	$Z_S = 2 + j10 \Omega$	$Z_L = 4 + j20 \Omega$	$Z_R = 4 + j20 \Omega$
Given:	$Z_{TR} = Z_L \times 10^{10} \Omega$		
Total impedance between <del>the</del> generators.			
Eq. (56)	$Z_{total} = \frac{(Z_L \times Z_{TR})}{(Z_L + Z_{TR})}$		
	$Z_{total} = \frac{((4 + j20) \Omega \times (4 + j20)^{10} \Omega)}{((4 + j20) \Omega + (4 + j20)^{10} \Omega)} \frac{((4 + j20) \Omega \times (4 + j20) \times 10^{10} \Omega)}{((4 + j20) \Omega + (4 + j20) \times 10^{10} \Omega)}$		
	$Z_{total} = 4 + j20 \Omega$		
Total system impedance.			
Eq. (57)	$Z_{sys} = Z_S + Z_{total} + Z_R$		
	$Z_{sys} = (2 + j10) \Omega + (4 + j20) \Omega + (4 + j20) \Omega$		
	$Z_{sys} = 10 + j50 \Omega$		
Total system current from sending-end source.			
Eq. (58)	$I_{sys} = \frac{E_S - E_R}{Z_{sys}}$		
	$I_{sys} = \frac{132,791 \angle 120^\circ V - 132,791 \angle 0^\circ V}{10 + j50 \Omega}$		
	$I_{sys} = 4,511 \angle 71.3^\circ A$		
The current, as measured by the relay on $Z_L$ (Figure 3), is only the current flowing through that line as determined by using the current divider equation.			
Eq. (59)	$I_L = I_{sys} \times \frac{Z_{TR}}{Z_L + Z_{TR}}$		
	$I_L = 4,511 \angle 71.3^\circ A$		
	$\times \frac{(4 + j20)^{10} \Omega}{(4 + j20) \Omega + (4 + j20)^{10} \Omega} \frac{(4 + j20) \times 10^{10} \Omega}{(4 + j20) \Omega + (4 + j20) \times 10^{10} \Omega}$		
	$I_L = 4,511 \angle 71.3^\circ A$		



Table 8 : Example Calculation ( <del>Parallel</del> Transfer Impedance Removed)	
The voltage, as measured by the relay on $Z_L$ (Figure 3), is the voltage drop from the sending-end source through the sending-end source impedance.	
Eq. (60)	$V_S = E_S - (Z_S \times I_{sys})$
	$V_S = 132,791 \angle 120^\circ V - [(2 + j10 \Omega) \times 4,511 \angle 71.3^\circ A]$
	$V_S = 95,757 \angle 106.1^\circ V$
The impedance seen by the relay on $Z_L$ .	
Eq. (61)	$Z_{L-Relay} = \frac{V_S}{I_L}$
	$Z_{L-Relay} = \frac{95,757 \angle 106.1^\circ V}{4,511 \angle 71.3^\circ A}$
	$Z_{L-Relay} = 17.434 + j12.113 \Omega$



**Figure 11:** This is an example of an unstable power swing region (i.e., the orange characteristic) with the parallel transfer impedance included. ~~The causing the~~ mho element characteristic (i.e., the blue circle) ~~meets to appear to meet~~ the PRC-026-1 – Attachment B, ~~Criteria~~ Criterion A because it is completely contained within the unstable power swing region. ~~However, including~~ Including the parallel transfer impedance in the calculation is not ~~compliant with~~ allowed by the PRC-026-1 – Attachment B ~~Criteria, Criterion~~ A.

In ~~the figure~~ Figure 11 above, the parallel transfer impedance is 5 times the line impedance. The unstable power swing region has expanded out beyond the mho element characteristic due to the infeed effect from the parallel current through the parallel transfer impedance, thus allowing the mho element characteristic to appear to meet ~~the~~ PRC-026-1 – Attachment B, ~~Criteria~~ Criterion A. ~~However, including~~ Including the parallel transfer impedance in the calculation is not ~~compliant with~~ allowed by the PRC-026-1 – Attachment B ~~Criteria, Criterion~~ A.

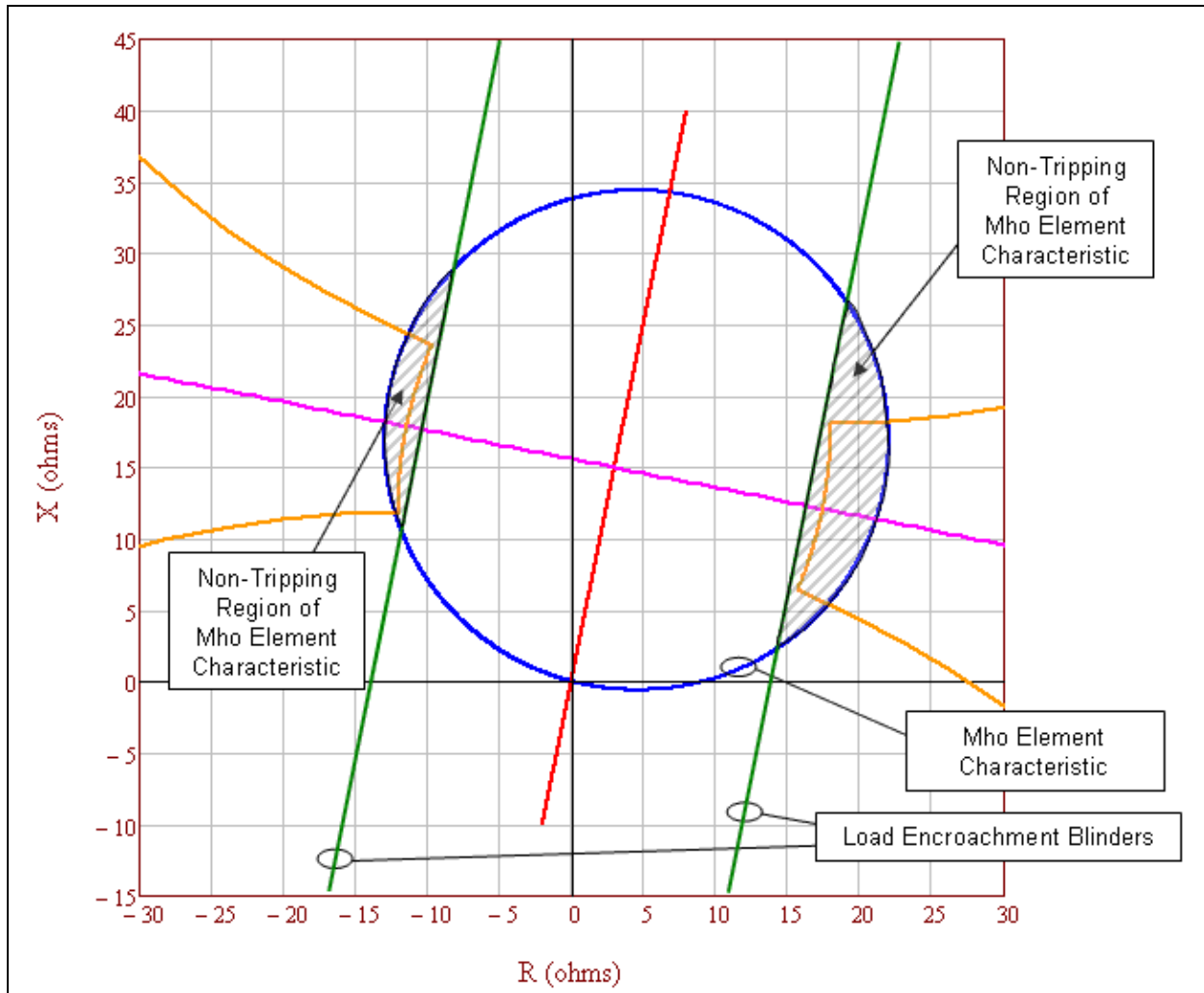
Table 9: Example Calculation ( <u>Parallel</u> Transfer Impedance Included)			
Calculations for the point at 120 degrees with equal source impedances. The total system current does not equal the line current. See Figure 11.			
Eq. (62)	$E_S = \frac{V_{LL} \angle 120^\circ}{\sqrt{3}}$		
	$E_S = \frac{230,000 \angle 120^\circ V}{\sqrt{3}}$		
	$E_S = 132,791 \angle 120^\circ V$		
Eq. (63)	$E_R = \frac{V_{LL} \angle 0^\circ}{\sqrt{3}}$		
	$E_R = \frac{230,000 \angle 0^\circ V}{\sqrt{3}}$		
	$E_R = 132,791 \angle 0^\circ V$		
Given impedance data.			
Given:	$Z_S = 2 + j10 \Omega$	$Z_L = 4 + j20 \Omega$	$Z_R = 4 + j20 \Omega$
Given:	$Z_{TR} = Z_L \times 5$		
	$Z_{TR} = (4 + j20) \Omega \times 5$		
	$Z_{TR} = 20 + j100 \Omega$		
Total impedance between <u>the</u> generators.			
Eq. (64)	$Z_{total} = \frac{(Z_L \times Z_{TR})}{(Z_L + Z_{TR})}$		
	$Z_{total} = \frac{(4 + j20) \Omega \times (20 + j100) \Omega}{(4 + j20) \Omega + (20 + j100) \Omega}$		
	$Z_{total} = 3.333 + j16.667 \Omega$		
Total system impedance.			
Eq. (65)	$Z_{sys} = Z_S + Z_{total} + Z_R$		
	$Z_{sys} = (2 + j10) \Omega + (3.333 + j16.667) \Omega + (4 + j20) \Omega$		
	$Z_{sys} = 9.333 + j46.667 \Omega$		
Total system current from sending-end source.			
Eq. (66)	$I_{sys} = \frac{E_S - E_R}{Z_{sys}}$		
	$I_{sys} = \frac{132,791 \angle 120^\circ V - 132,791 \angle 0^\circ V}{9.333 + j46.667 \Omega}$		

Table 9: Example Calculation ( <u>Parallel</u> Transfer Impedance Included)	
	$I_{sys} = 4,832833 \angle 71.3^\circ A$
The current, as measured by the relay on $Z_L$ (Figure 3), is only the current flowing through that line as determined by using the current divider equation.	
Eq. (67)	$I_L = I_{sys} \times \frac{Z_{TR}}{Z_L + Z_{TR}}$
	$I_L = 4,832833 \angle 71.3^\circ A$ $\times \frac{(20 + j100) \Omega}{(9.333 + j46.667) \Omega + (20 + j100) \Omega} \frac{(20 + j100) \Omega}{(4 + j20) \Omega + (20 + j100) \Omega}$
	$I_L = 4,027.4 \angle 71.3^\circ A$
The voltage, as measured by the relay on $Z_L$ (Figure 3), is the voltage drop from the sending-end source through the sending-end source impedance.	
Eq. (68)	$V_S = E_S - (Z_S \times I_{sys})$
	$V_S = 132,791 \angle 120^\circ V$ $- [(2 + j10 \Omega) \times 4,027 \angle 71.3^\circ A] - [(2 + j10 \Omega) \times 4,833 \angle 71.3^\circ A]$
	$V_S = 93,417 \angle 104.7^\circ V$
The impedance seen by the relay on $Z_L$ .	
Eq. (69)	$Z_{L-Relay} = \frac{V_S}{I_L}$
	$Z_{L-Relay} = \frac{93,417 \angle 104.7^\circ V}{4,027 \angle 71.3^\circ A}$
	$Z_{L-Relay} = 19.366 + j12.767 \Omega$

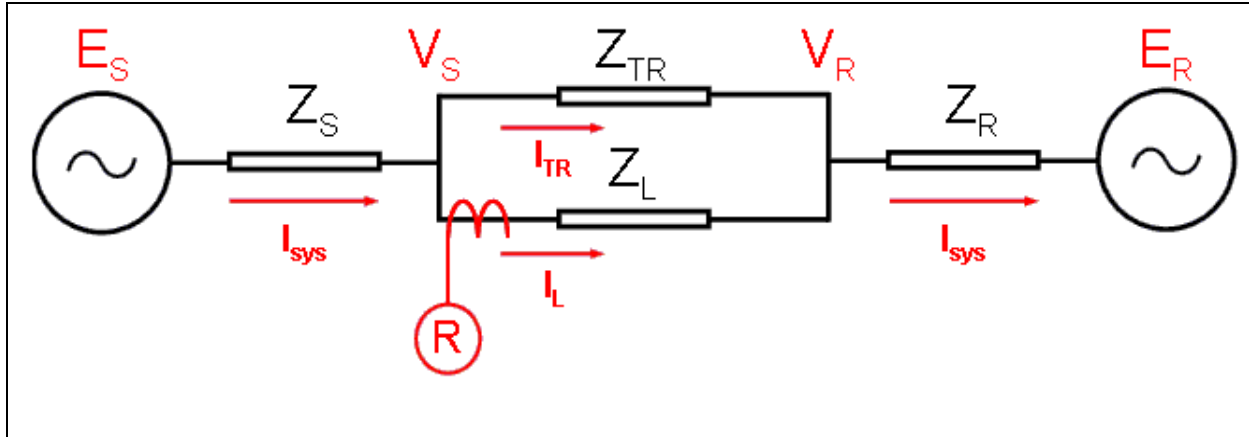
**Table 10: Percent Increase of a Lens Due To Parallel Transfer Impedance.**

The following demonstrates the percent size increase of the lens characteristic for  $Z_{TR}$  in multiples of  $Z_L$  with the parallel transfer impedance included.

$Z_{TR}$ in multiples of $Z_L$	Percent increase of lens with equal EMF sources (Infinite source as reference)
Infinite	N/A
1000	0.05%
100	0.46%
10	4.63%
5	9.27%
2	23.26%
1	46.76%
0.5	94.14%
0.25	189.56%



**Figure 12:** The tripping portion of the mho element characteristic (i.e., the blue circle) not blocked by load encroachment (i.e., the parallel green lines) of the mho element characteristic (i.e., the blue circle) is completely contained within the unstable power swing region (i.e., the orange characteristic). Therefore, the mho element characteristic meets the PRC-026-1 – Attachment B, Criteria~~Criterion~~ A.



**Figure 13:** The infeed diagram shows the impedance in front of the relay R with the parallel transfer impedance included. As the parallel transfer impedance approaches infinity, the impedances seen by the relay R in the forward direction becomes  $Z_L + Z_R$ .

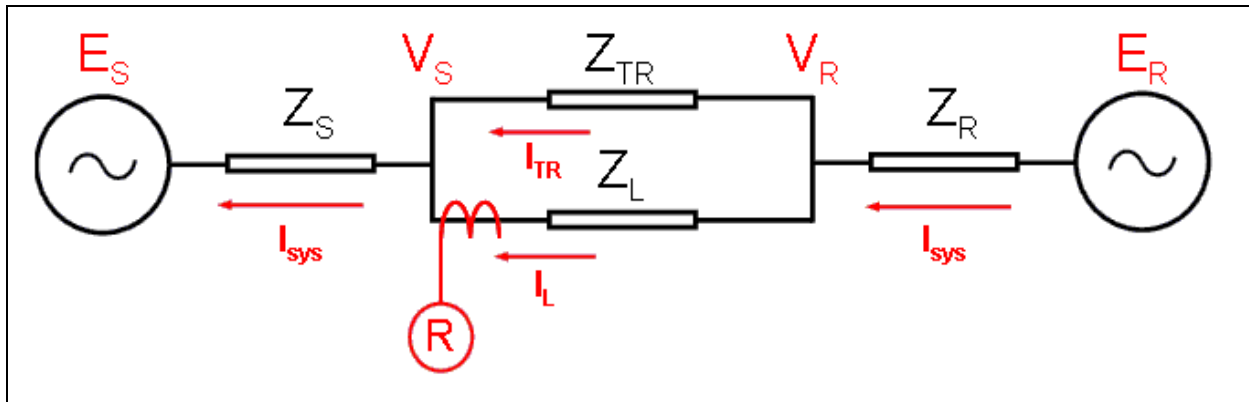
**Table 11-3 Calculations (System Apparent Impedance in the forward direction)**

The following equations are provided for calculating the apparent impedance back to the  $E_R$  source voltage as seen by relay R. Infeed equations from  $V_S$  to source  $E_R$  where  $E_R = 0$ . See Figure 13.

Eq. (70)	$I_L = \frac{V_S - V_R}{Z_L}$			
Eq. (71)	$I_{sys} = \frac{V_R - E_R}{Z_R}$			
Eq. (72)	$I_{sys} = I_L + I_{TR}$			
Eq. (73)	$I_{sys} = \frac{V_R}{Z_R}$	Since $E_R = 0$	Rearranged:	$V_R = I_{sys} \times Z_R$
Eq. (74)	$I_L = \frac{V_S - I_{sys} \times Z_R}{Z_L}$			
Eq. (75)	$I_L = \frac{V_S - [(I_L + I_{TR}) \times Z_R]}{Z_L}$			
Eq. (76)	$V_S = (I_L \times Z_L) + (I_L \times Z_R) + (I_{TR} \times Z_R)$			
Eq. (77)	$Z_{Relay} = \frac{V_S}{I_L} = Z_L + Z_R + \frac{I_{TR} \times Z_R}{I_L} = Z_L + Z_R \times \left(1 + \frac{I_{TR}}{I_L}\right)$			
Eq. (78)	$I_{TR} = I_{sys} \times \frac{Z_L}{Z_L + Z_{TR}}$			
Eq. (79)	$I_L = I_{sys} \times \frac{Z_{TR}}{Z_L + Z_{TR}}$			

**Table 11: Calculations (System Apparent Impedance in the forward direction)**

Eq. (80)	$\frac{I_{TR}}{I_L} = \frac{Z_L}{Z_{TR}}$
The infeed equations shows the impedance in front of the relay R (Figure 13) with the parallel transfer impedance included. As the parallel transfer impedance approaches infinity, the impedances seen by the relay R in the forward direction becomes $Z_L + Z_R$ .	
Eq. (81)	$Z_{Relay} = Z_L + Z_R \times \left(1 + \frac{Z_L}{Z_{TR}}\right)$



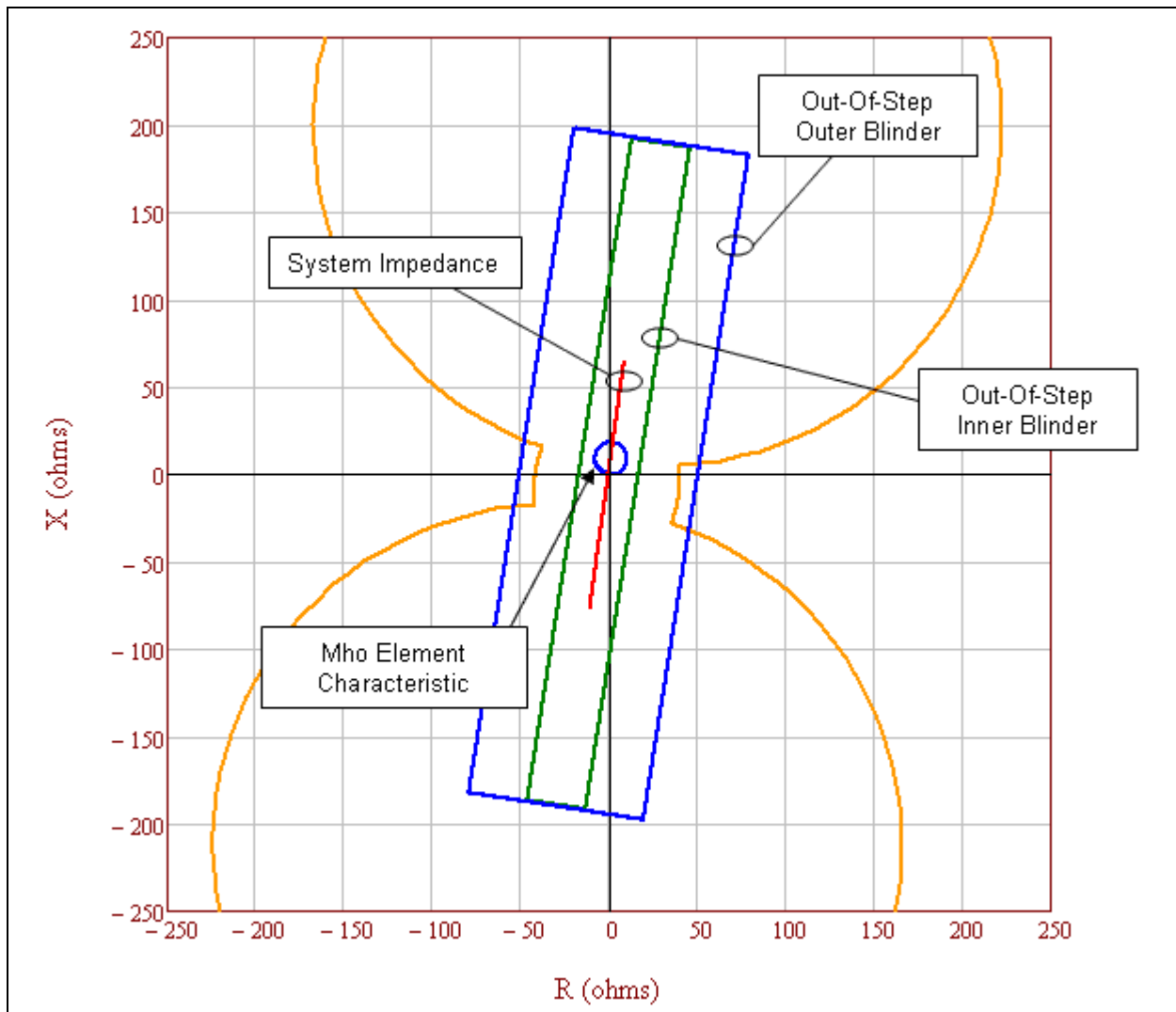
**Figure 14:** The infeed diagram shows the impedance behind relay R with the parallel transfer impedance included. As the parallel transfer impedance approaches infinity, the impedances seen by the relay R in the reverse direction becomes  $Z_S$ .

**Table 12: Calculations (System Apparent Impedance in the reverse direction)**

The following equations are provided for calculating the apparent impedance back to the $E_S$ source voltage as seen by relay R. Infeed equations from $V_R$ back to source $E_S$ where $E_S = 0$ . See Figure 14.				
Eq. (82)	$I_L = \frac{V_R - V_S}{Z_L}$			
Eq. (83)	$I_{sys} = \frac{V_S - E_S}{Z_S}$			
Eq. (84)	$I_{sys} = I_L + I_{TR}$			
Eq. (85)	$I_{sys} = \frac{V_S}{Z_S}$	Since $E_S = 0$	Rearranged:	$V_S = I_{sys} \times Z_S$
Eq. (86)	$I_L = \frac{V_R - I_{sys} \times Z_S}{Z_L}$			



Table 12-3: Calculations (System Apparent Impedance in the <b>reverse direction</b> <u>Reverse Direction</u> )		
Eq. (87)	$I_L = \frac{V_R - [(I_L + I_{TR}) \times Z_S]}{Z_L}$	
Eq. (88)	$V_R = (I_L \times Z_L) + (I_L \times Z_S) + (I_{TR} \times Z_{RS})$	
Eq. (89)	$Z_{Relay} = \frac{V_R}{I_L} = Z_L + Z_S + \frac{I_{TR} \times Z_S}{I_L} = Z_L + Z_S \times \left(1 + \frac{I_{TR}}{I_L}\right)$	
Eq. (90)	$I_{TR} = I_{sys} \times \frac{Z_L}{Z_L + Z_{TR}}$	
Eq. (91)	$I_L = I_{sys} \times \frac{Z_{TR}}{Z_L + Z_{TR}}$	
Eq. (92)	$\frac{I_{TR}}{I_L} = \frac{Z_L}{Z_{TR}}$	
The infeed equations shows the impedance behind relay R ( <a href="#">Figure 14</a> ) with the parallel transfer impedance included. As the parallel transfer impedance approaches infinity, the impedances seen by the relay R in the reverse direction becomes $Z_S$ .		
Eq. (93)	$Z_{Relay} = Z_L + Z_S \times \left(1 + \frac{Z_L}{Z_{TR}}\right)$	As seen by relay R at the receiving-end of the line.
Eq. (94)	$Z_{Relay} = Z_S \times \left(1 + \frac{Z_L}{Z_{TR}}\right)$	Subtract $Z_L$ for relay R impedance as seen at sending-end of the line.



**Figure 15:** Out-of-step trip (OST) inner blinder (i.e., the parallel green lines) meets the PRC-026-1 – Attachment B, Criteria Criterion A because the inner OST blinder initiates tripping either On-The-Way-In or On-The-Way-Out. Since the inner blinder is completely contained within the unstable power swing region (i.e., the orange characteristic), it meets the PRC-026-1 – Attachment B, Criteria Criterion A.

**Table 13: Example Calculation (Voltage Ratios)**

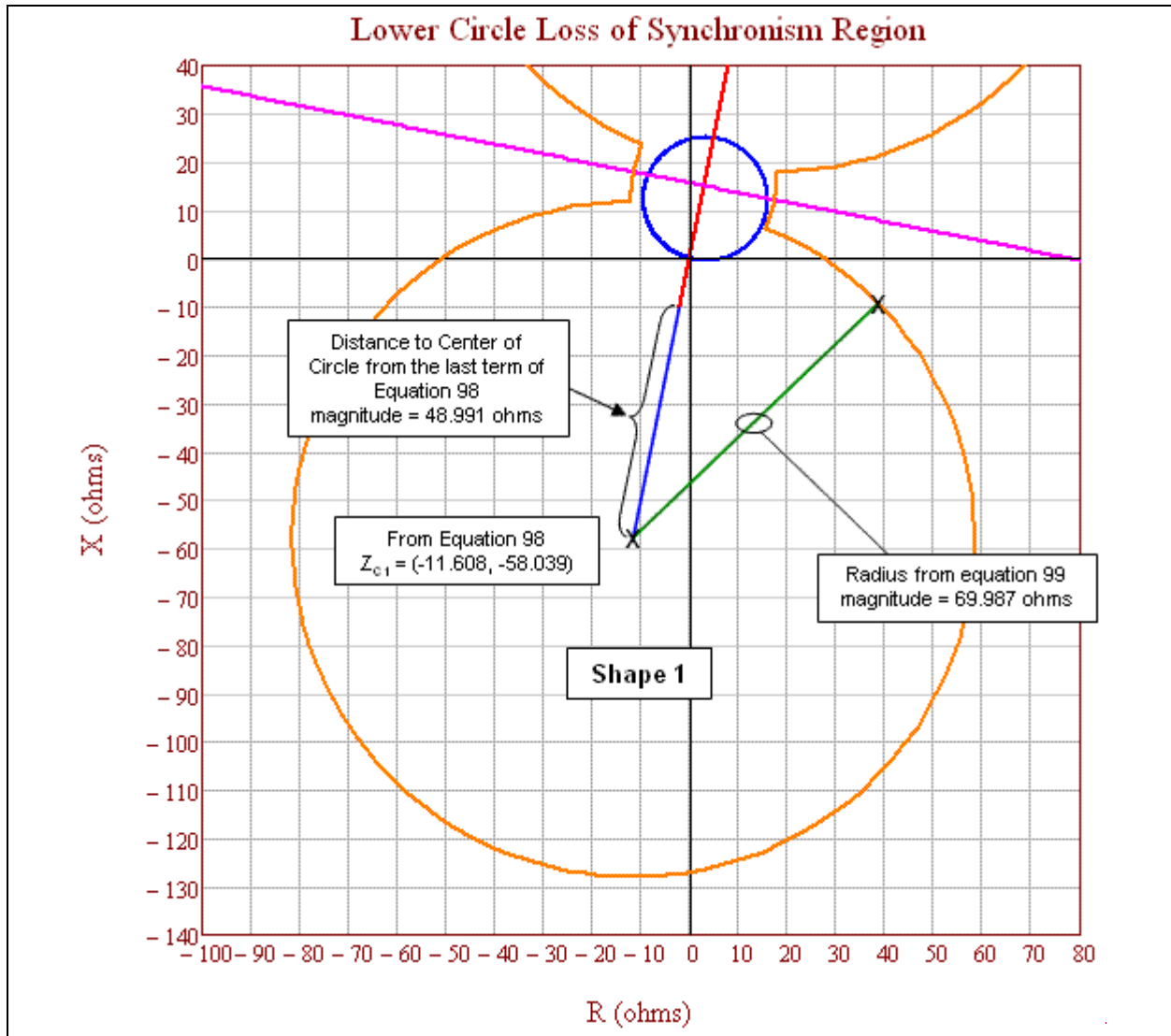
These calculations are based on the loss-of-synchronism characteristics for the cases of  $N < 1$  and  $N > 1$  as found in the *Application of Out-of-Step Blocking and Tripping Relays*, GER-3180, p. 12, Figure 13.<sup>19</sup> The GE illustration shows the formulae used to calculate the radius and center of the circles that make up the ends of the portion of the lens.

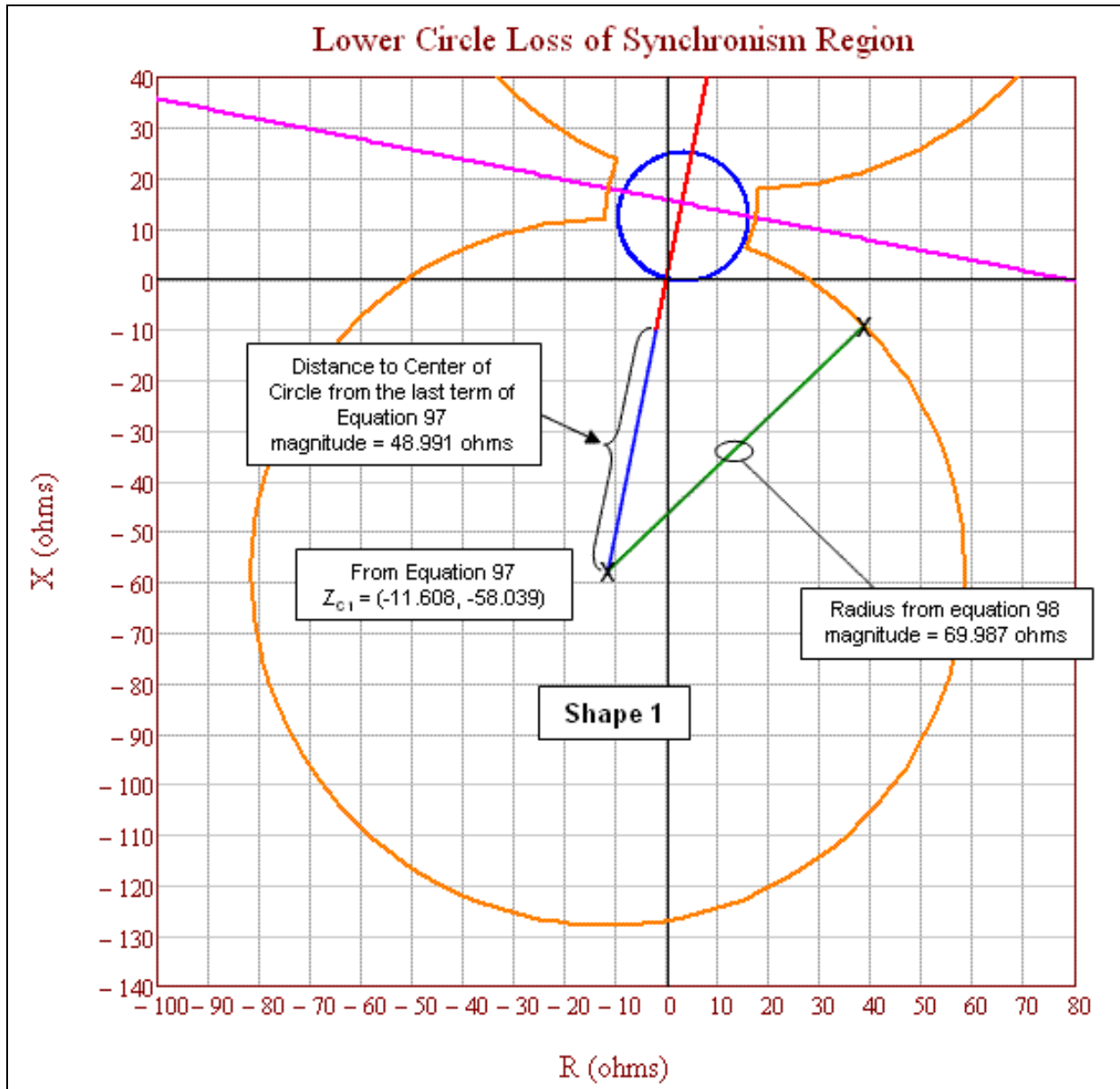
Voltage ratio equations, source impedance equation with infeed formulae applied, and circle equations.

Given:	$E_S = 0.7$	$E_R = 1.0$
Eq. (95)	$N_a = \frac{ E_S }{ E_R } N = \frac{0.7}{1.0} = 0.7$	
Eq. (96)	$N_b = \frac{ E_R }{ E_S } = \frac{1.0}{0.7} = 1.43$	
The total system impedance as seen by the relay with infeed formulae applied.		
Given:	$Z_S = 2 + j10 \Omega$	$Z_L = 4 + j20 \Omega$ $Z_R = 4 + j20 \Omega$
Given:	$Z_{TR} = Z_L \times 10^{10} \Omega$	
	$Z_{TR} = (4 + j20) \times 10^{10} \Omega$	
Eq. (9796)	$Z_{sys} = Z_S \times \left(1 + \frac{Z_L}{Z_{TR}}\right) + \left[Z_L + Z_R \times \left(1 + \frac{Z_L}{Z_{TR}}\right)\right]$	
	$Z_{sys} = 10 + j50 \Omega$	
The calculated coordinates of the lower <u>loss-of-synchronism</u> circle center.		
Eq. (9897)	$Z_{C1} = - \left[ Z_S \times \left(1 + \frac{Z_L}{Z_{TR}}\right) \right] - \left[ \frac{N_a^2 \times Z_{sys}}{1 - N_a^2} \right] \left[ \frac{N^2 \times Z_{sys}}{1 - N^2} \right]$	
	$Z_{C1} = - \left[ (2 + j10) \Omega \times \left(1 + \frac{(4 + j20) \Omega}{(4 + j20) \times 10^{10} \Omega}\right) \right] \left[ (2 + j10) \Omega \right. \\ \left. \times \left(1 + \frac{(4 + j20) \Omega}{(4 + j20) \times 10^{10} \Omega}\right) \right] - \left[ \frac{0.7^2 \times (10 + j50) \Omega}{1 - 0.7^2} \right]$	
	$Z_{C1} = -11.608 - j58.039 \Omega$	
The calculated radius of the lower <u>loss-of-synchronism</u> circle.		
Eq. (9998)	$r_a = \left[ \frac{N_a \times Z_{sys}}{1 - N_a^2} \right] \left  \frac{N \times Z_{sys}}{1 - N^2} \right $	
	$r_a = \left[ \frac{0.7 \times (10 + j50) \Omega}{1 - 0.7^2} \right] \left  \frac{0.7 \times (10 + j50) \Omega}{1 - 0.7^2} \right $	

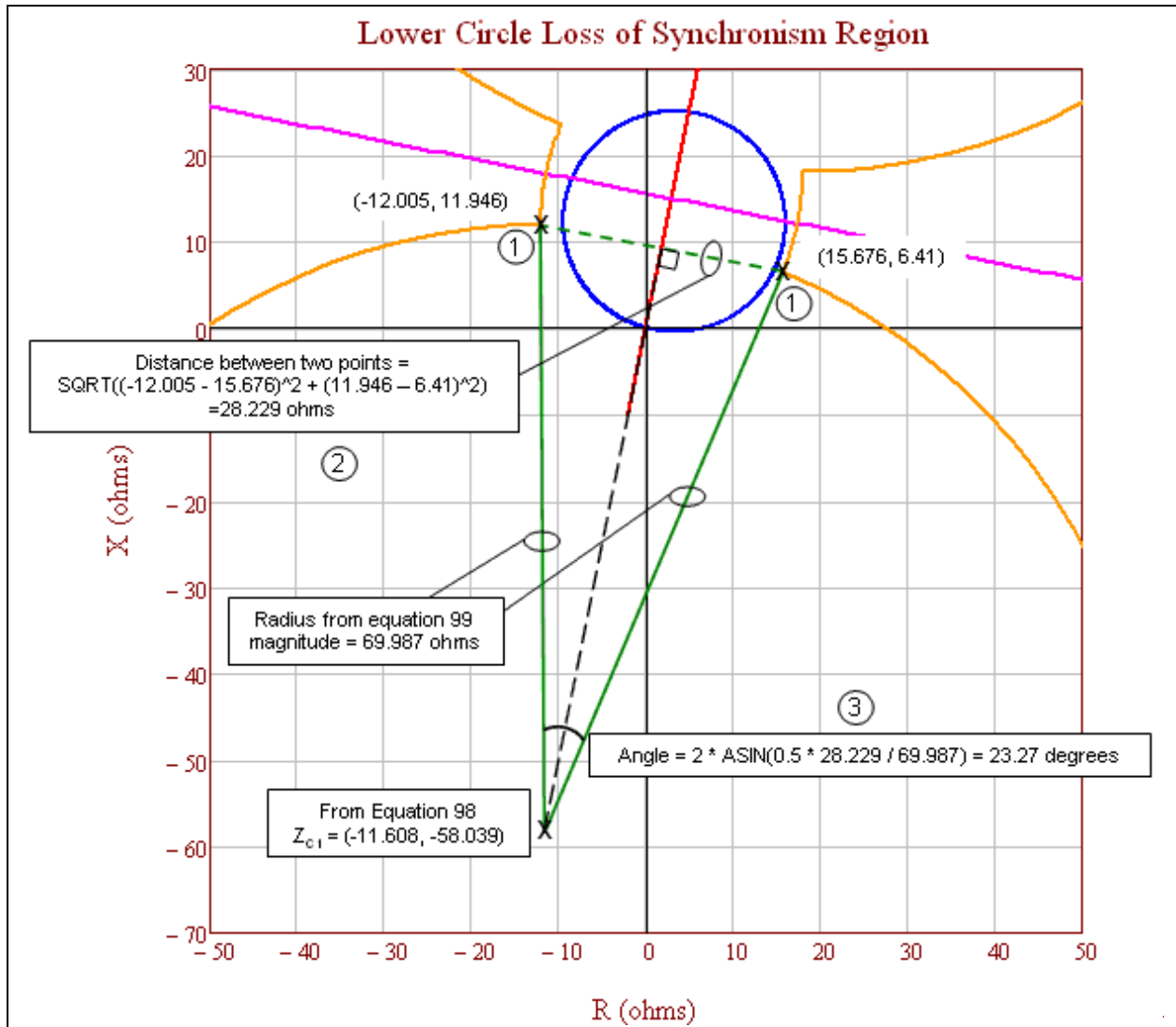
<sup>19</sup> <http://store.gedigitalenergy.com/faq/Documents/Alps/GER-3180.pdf>

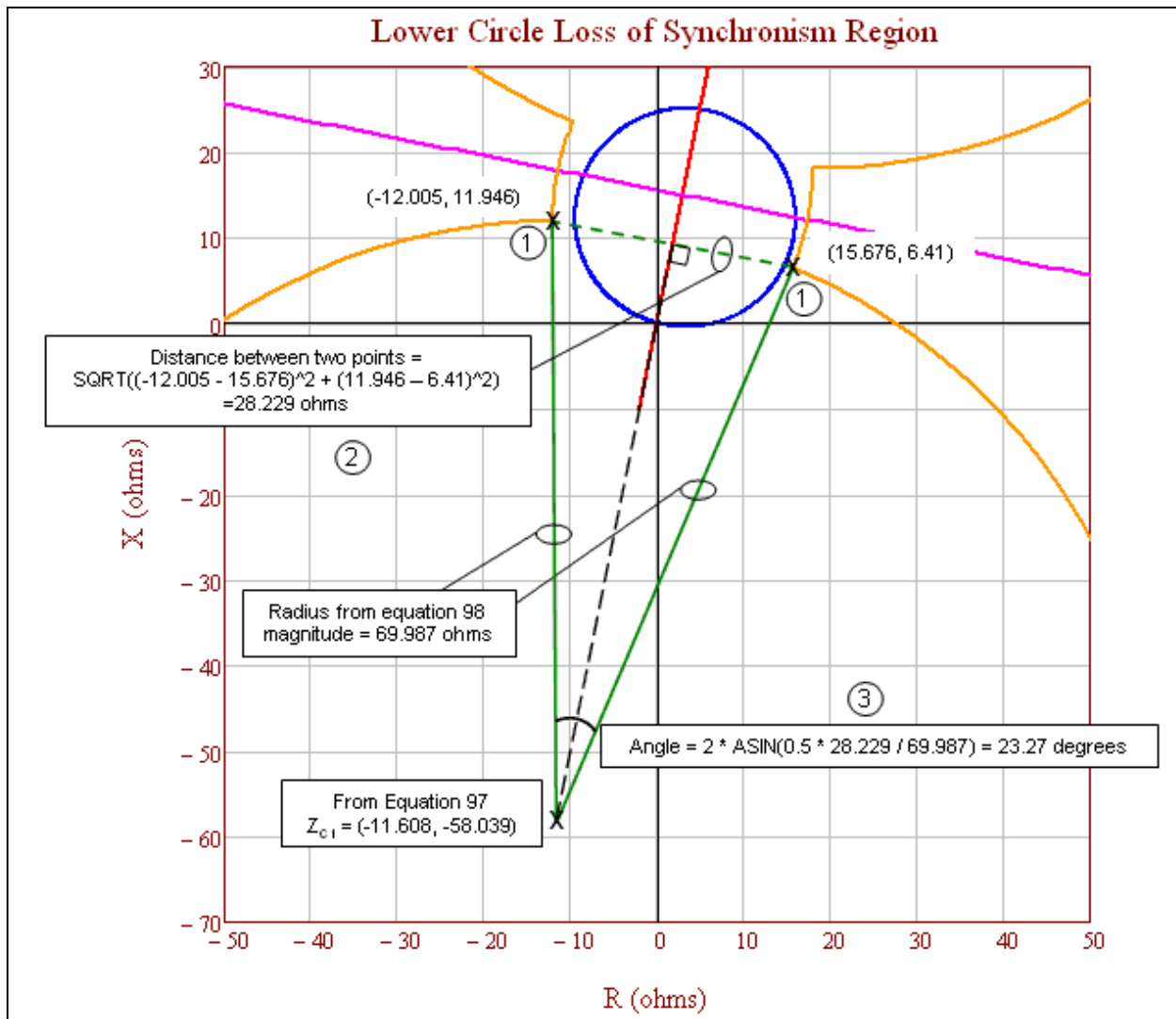
Table 13: Example Calculation (Voltage Ratios)	
	$r_a = 69.987 \Omega$
The calculated coordinates of the upper <u>loss-of-synchronism</u> circle center.	
<u>Given:</u>	$E_S = 1.0$ <span style="margin-left: 100px;"><math>E_R = 0.7</math></span>
Eq. (99)	$N = \frac{ E_S }{ E_R } = \frac{1.0}{0.7} = 1.43$
Eq. (100)	$Z_{C2} = Z_L + \left[ Z_R \times \left( 1 + \frac{Z_L}{Z_{TR}} \right) \right] + \left[ \frac{Z_{sys}}{N_b^2 - 1} \right] \left[ \frac{Z_{sys}}{N^2 - 1} \right]$
	$Z_{C2} = \left[ (4 + j20) \Omega \times \left( 1 + \frac{(4 + j20) \Omega}{(4 + j20) \times 10^9 \Omega} \right) \right] + \left[ \frac{(10 + j50) \Omega}{1.43^2 - 1} \right] Z_{C2}$ $= 4 + j20 \Omega + \left[ (4 + j20) \Omega \times \left( 1 + \frac{(4 + j20) \Omega}{(4 + j20) \times 10^{10} \Omega} \right) \right]$ $+ \left[ \frac{(10 + j50) \Omega}{1.43^2 - 1} \right]$
	$Z_{C2} = 17.608 + j88.039 \Omega$
The calculated radius of the upper <u>loss-of-synchronism</u> circle.	
Eq. (101)	$r_b = \left[ \frac{N_b \times Z_{sys}}{N_b^2 - 1} \right] \left  \frac{N \times Z_{sys}}{N^2 - 1} \right $
	$r_b = \left[ \frac{1.43 \times (10 + j50) \Omega}{1.43^2 - 1} \right] \left  \frac{1.43 \times (10 + j50) \Omega}{1.43^2 - 1} \right $
	$r_b = 69.987 \Omega$





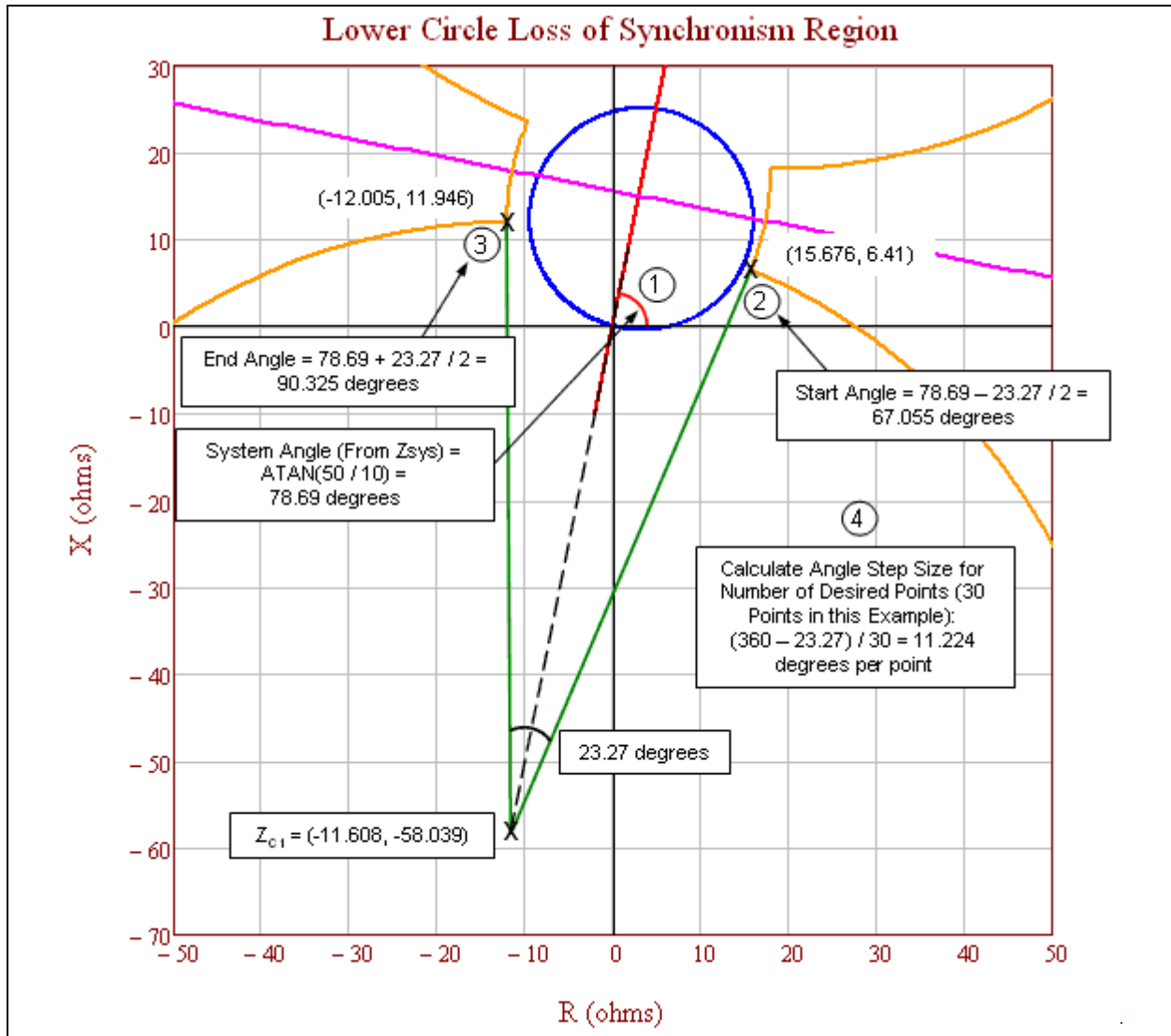
**Figure 15a:** Lower circle loss-of-synchronism region showing the coordinates of the circle center and the circle radius.

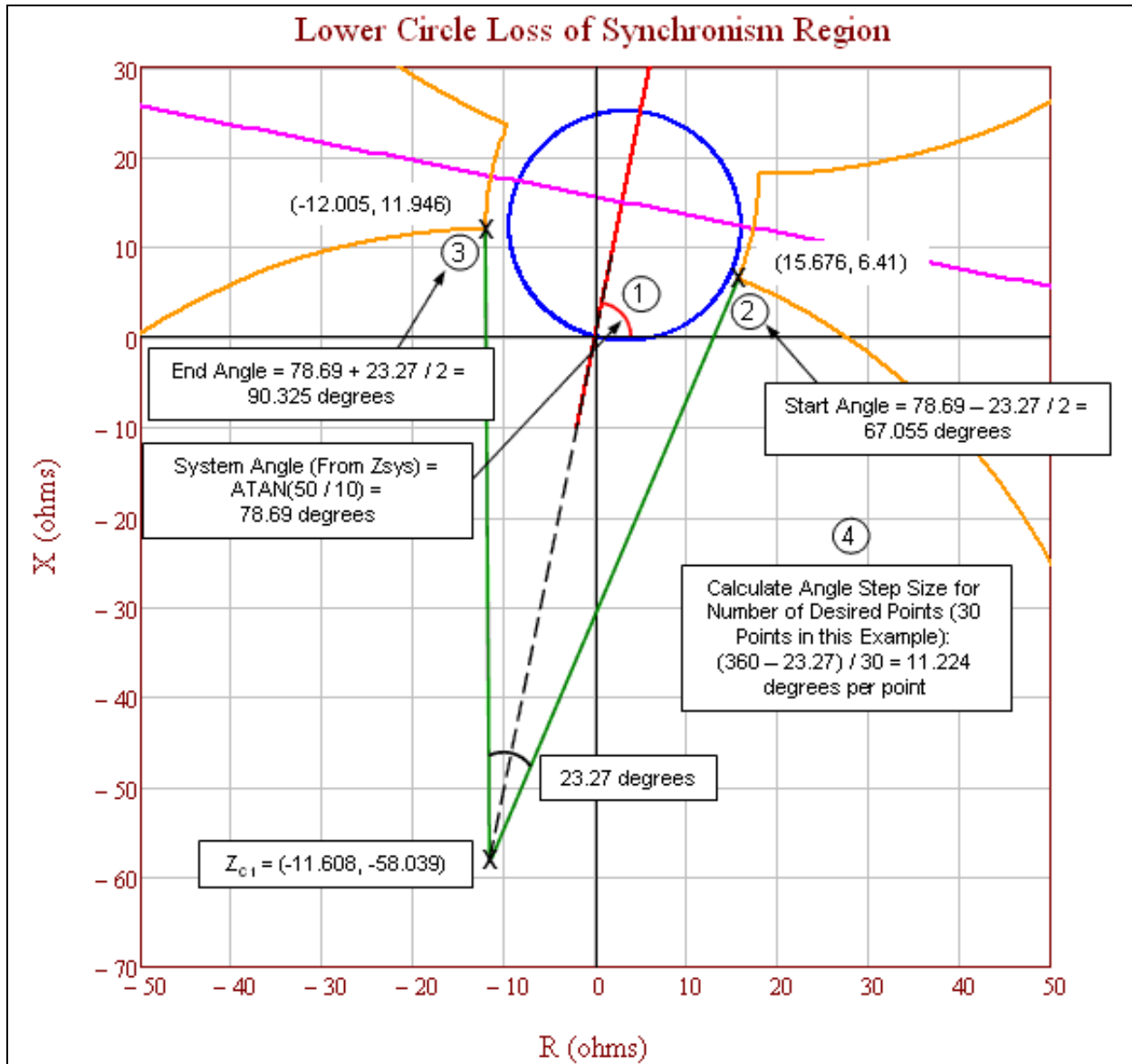




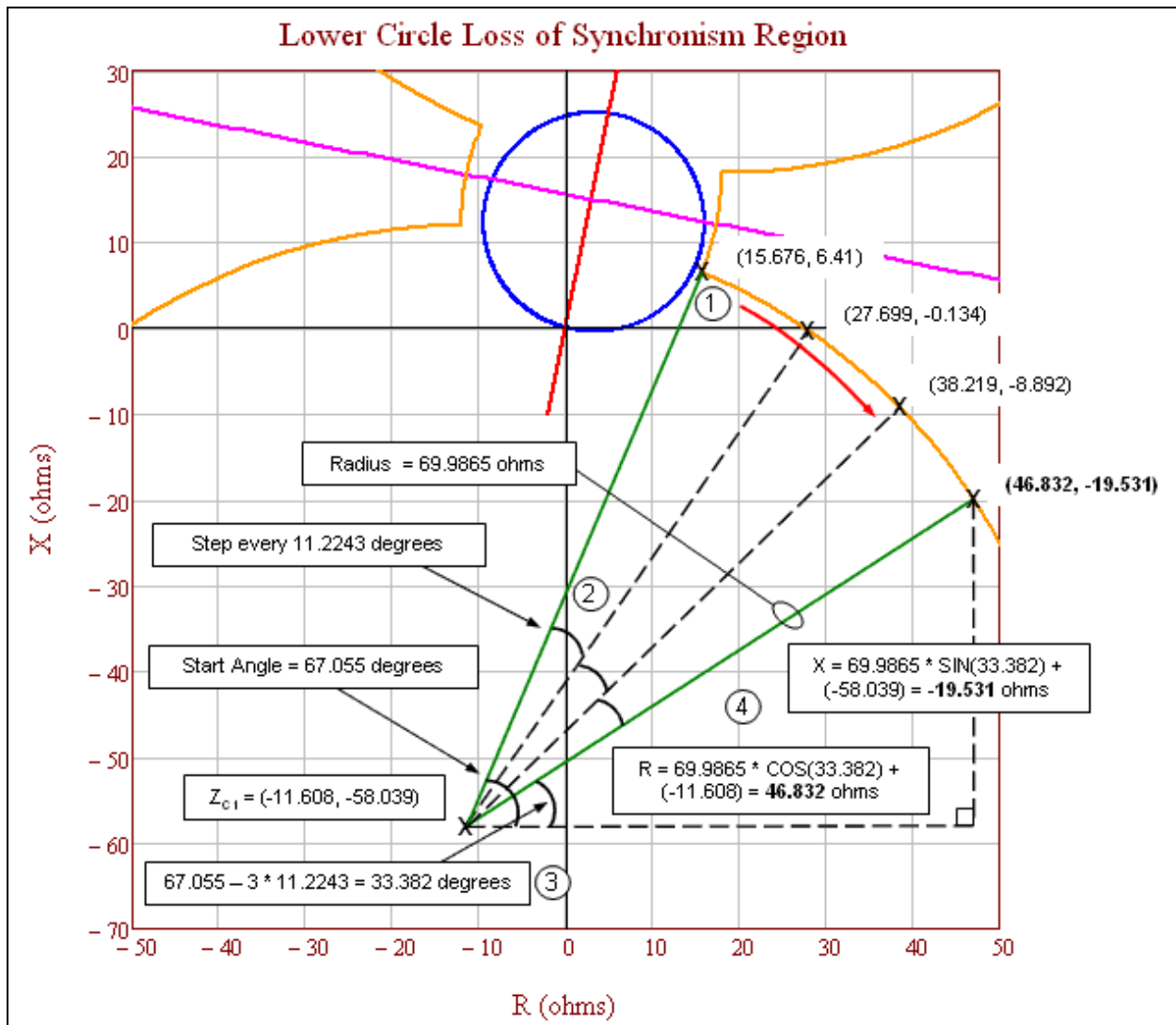
**Figure 15b:** Lower circle loss-of-synchronism region showing the first three steps to calculate the coordinates of the points on the circle. 1) Identify the lower circle loss-of-synchronism points that intersect the lens shape where the sending-end to receiving-end voltage ratio is 0.7 (see lens shape calculations in Tables 2-7). 2) Calculate the distance between the two lower circle loss-of-synchronism points identified in Step 1. 3) Calculate the angle of arc that connects the two lower circle loss-of-synchronism points identified in Step 1.



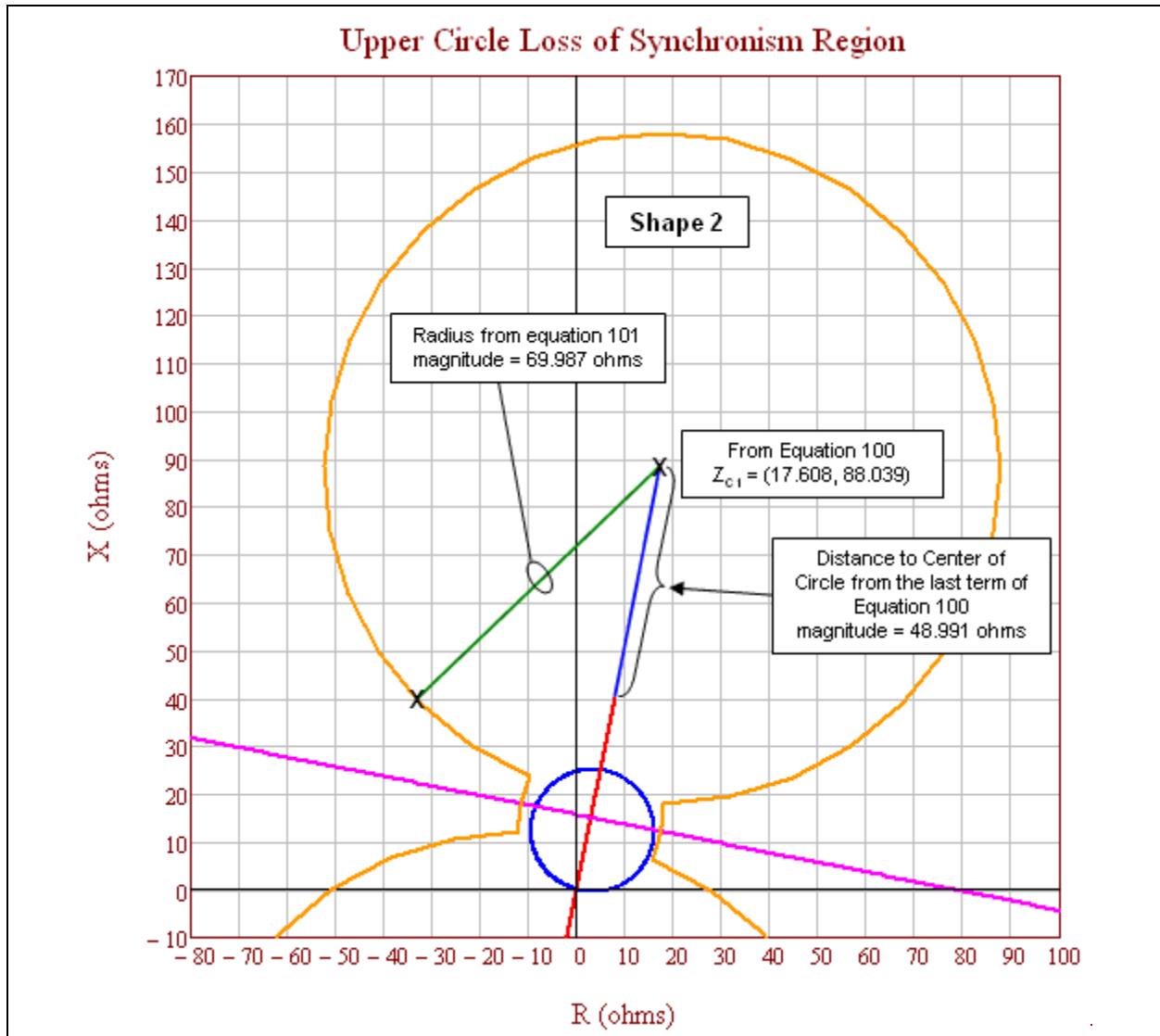


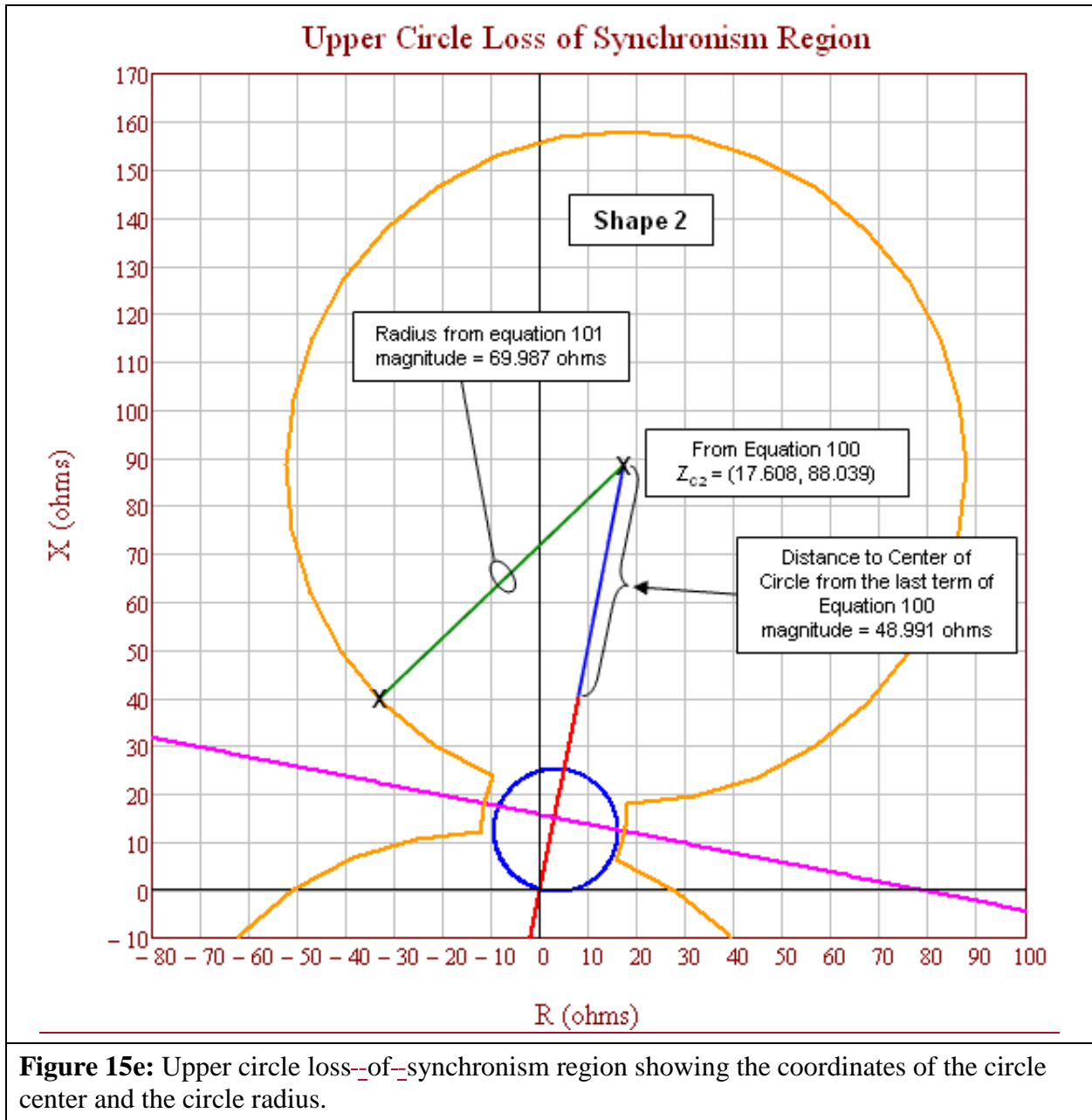


**Figure 15c:** Lower circle loss-of-synchronism region showing the steps to calculate the start angle, end angle, and the angle step size for the desired number of calculated points. 1) Calculate the system angle. 2) Calculate the start angle. 3) Calculate the end angle. 4) Calculate the angle step size for the desired number of points.

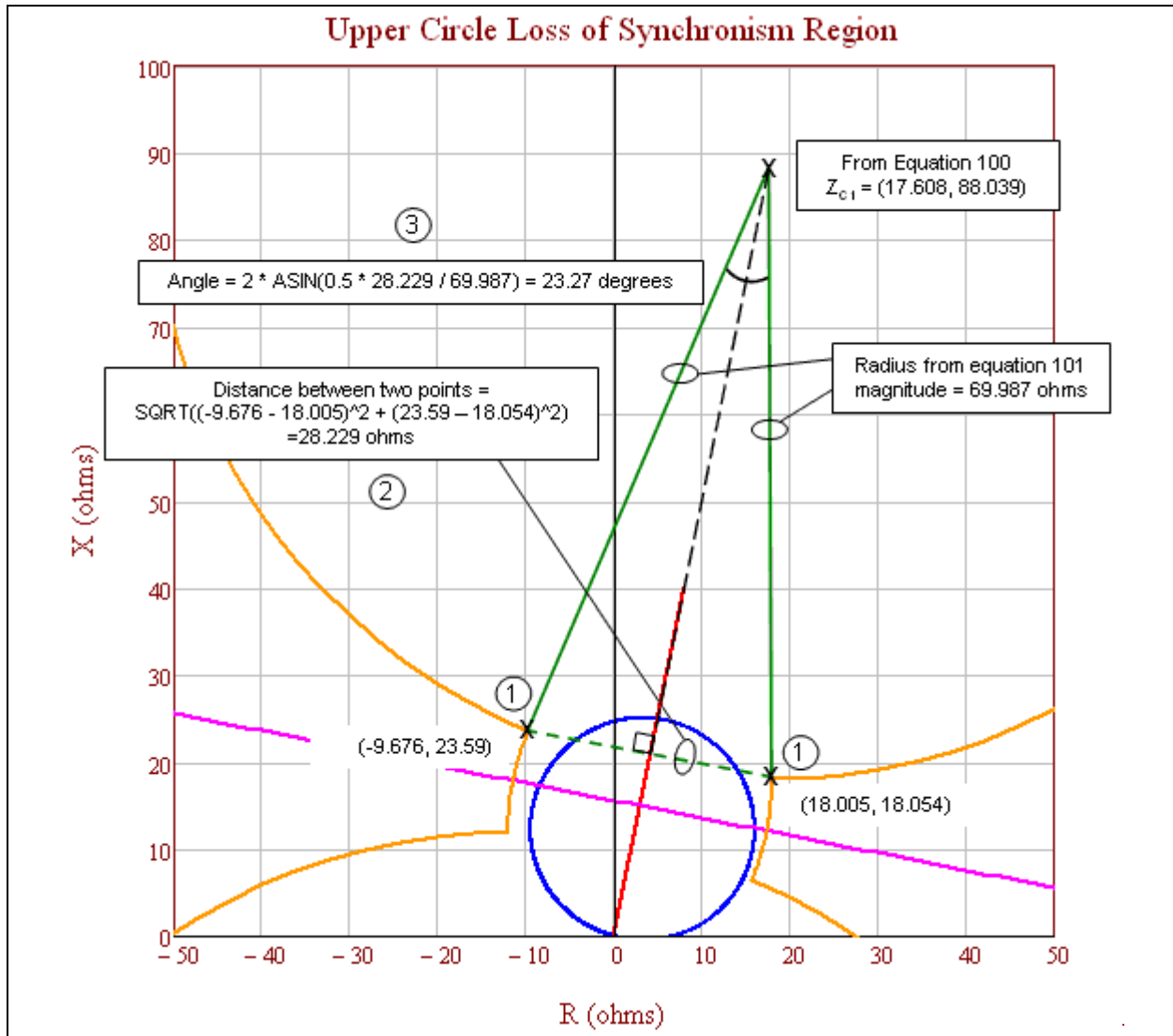


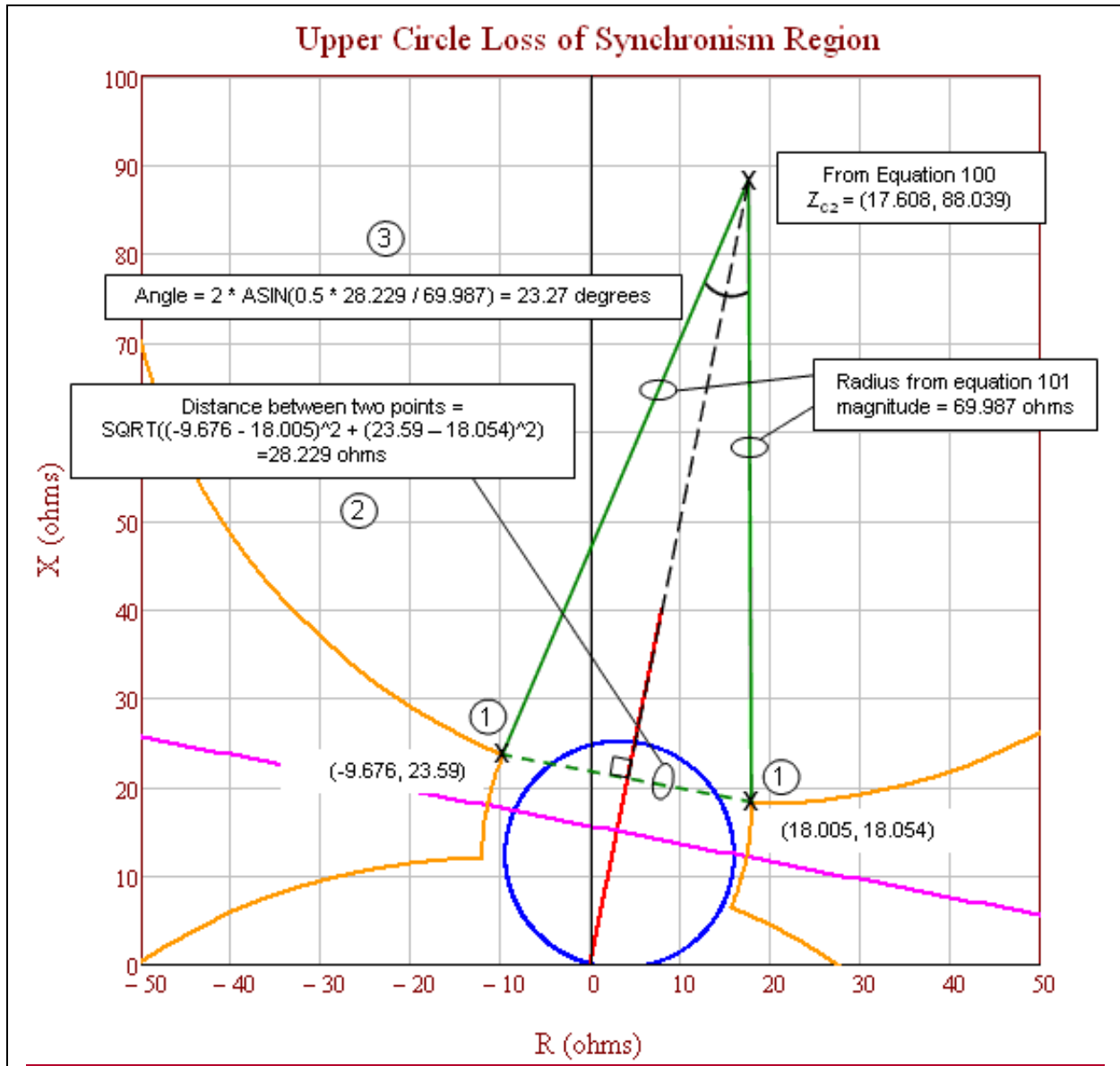
**Figure 15d:** Lower circle loss-of-synchronism region showing the final steps to calculate the coordinates of the points on the circle. 1) Start at the intersection with the lens shape and proceed in a clockwise direction. 2) Advance the step angle for each point. 3) Calculate the new angle after step advancement. 4) Calculate the R–X coordinates.



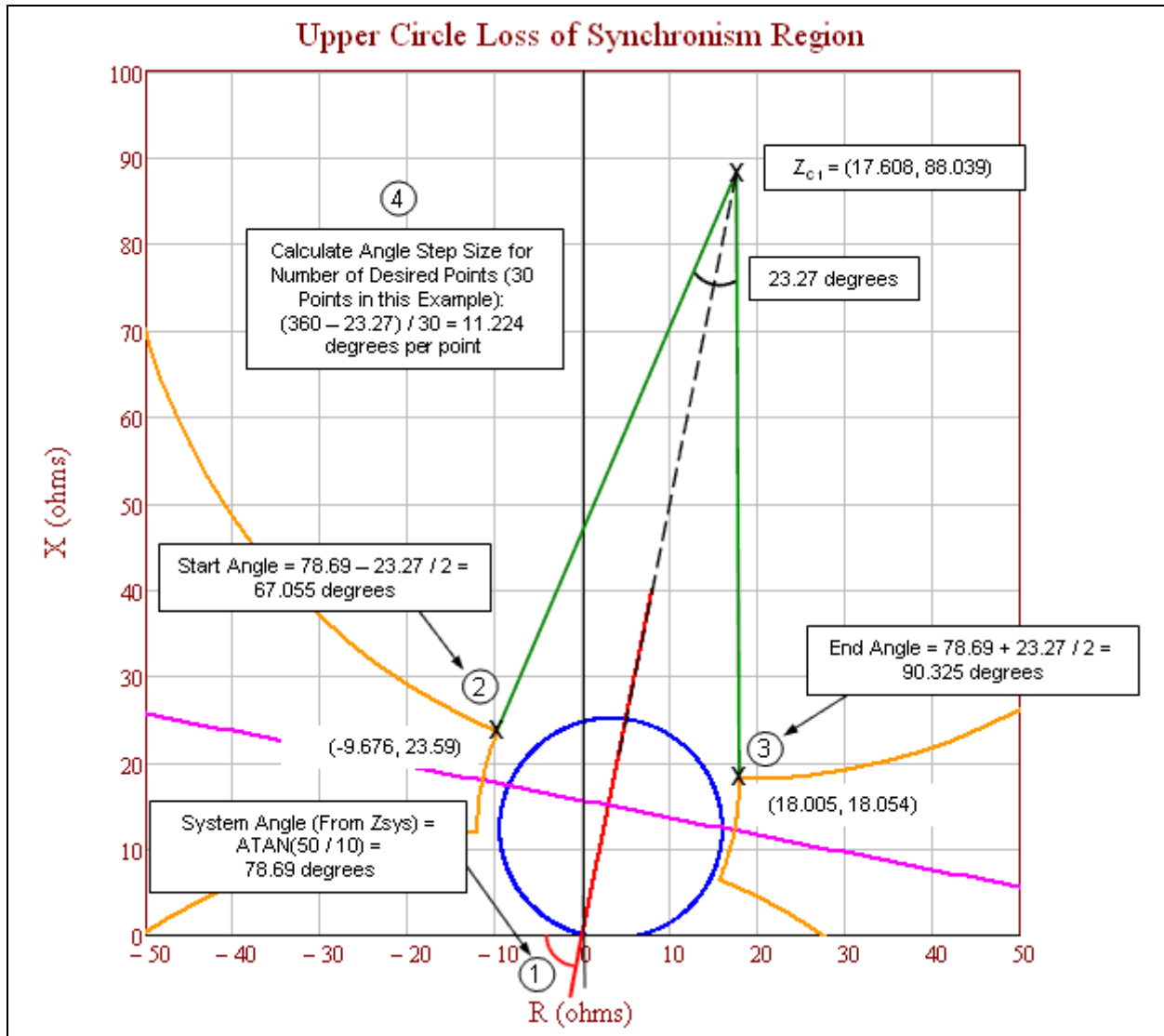


**Figure 15e:** Upper circle loss-of-synchronism region showing the coordinates of the circle center and the circle radius.

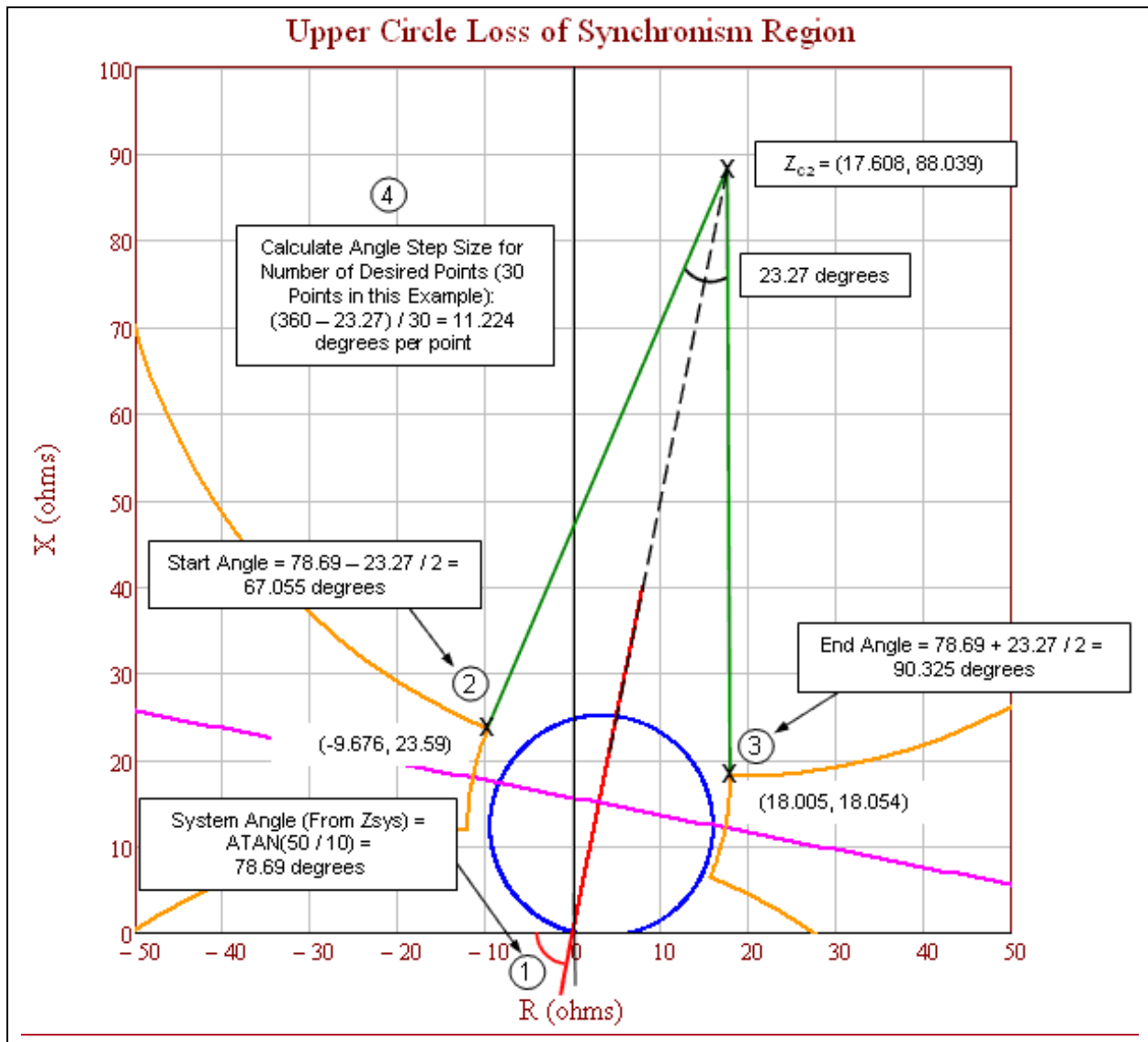




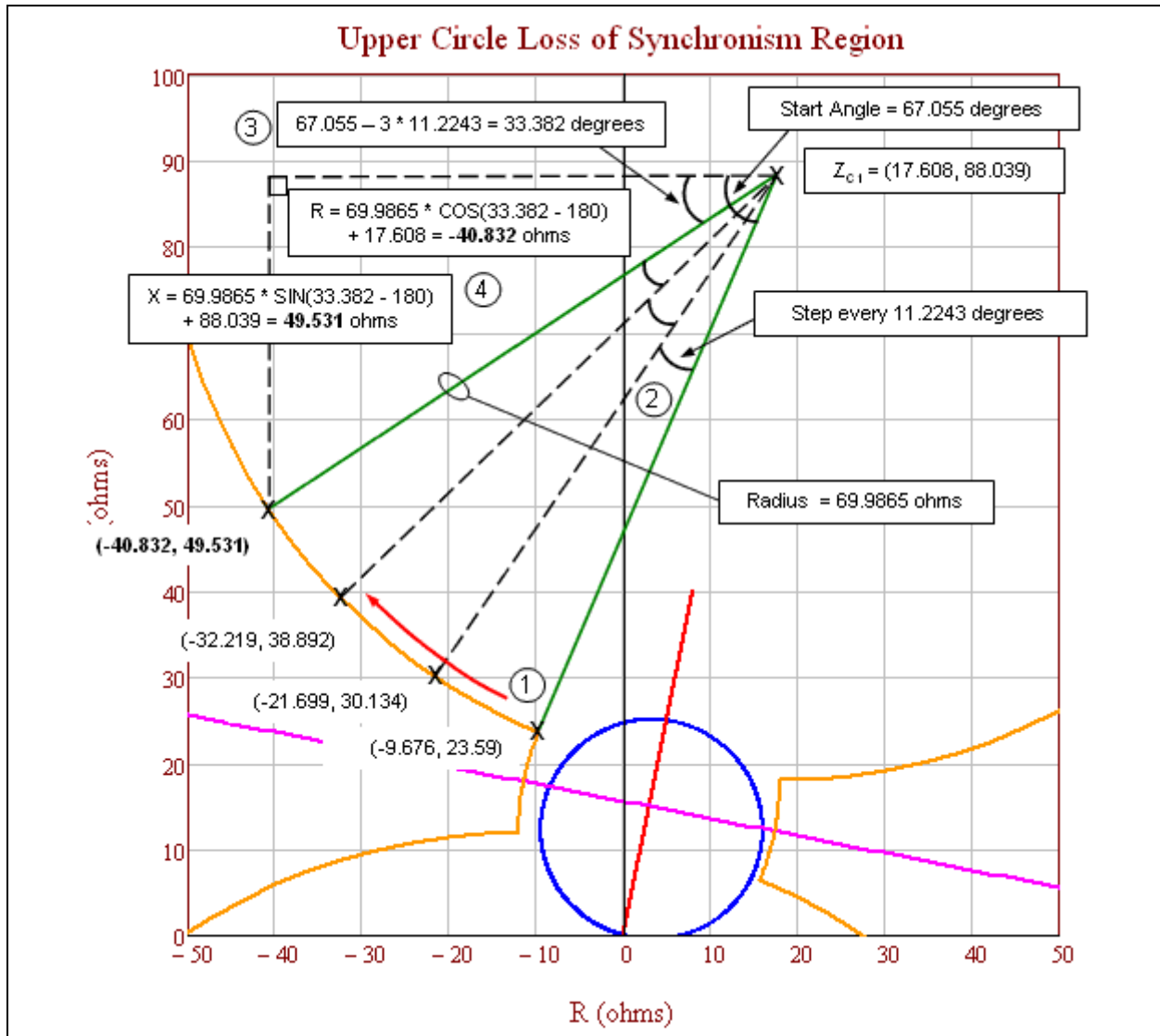
**Figure 15f:** Upper circle loss-of-synchronism region showing the first three steps to calculate the coordinates of the points on the circle. 1) Identify the upper circle points that intersect the lens shape where the sending-end to receiving-end voltage ratio is 1.43 (see lens shape calculations in Tables 2-7). 2) Calculate the distance between the two upper circle points identified in Step 1. 3) Calculate the angle of arc that connects the two upper circle points identified in Step 1.

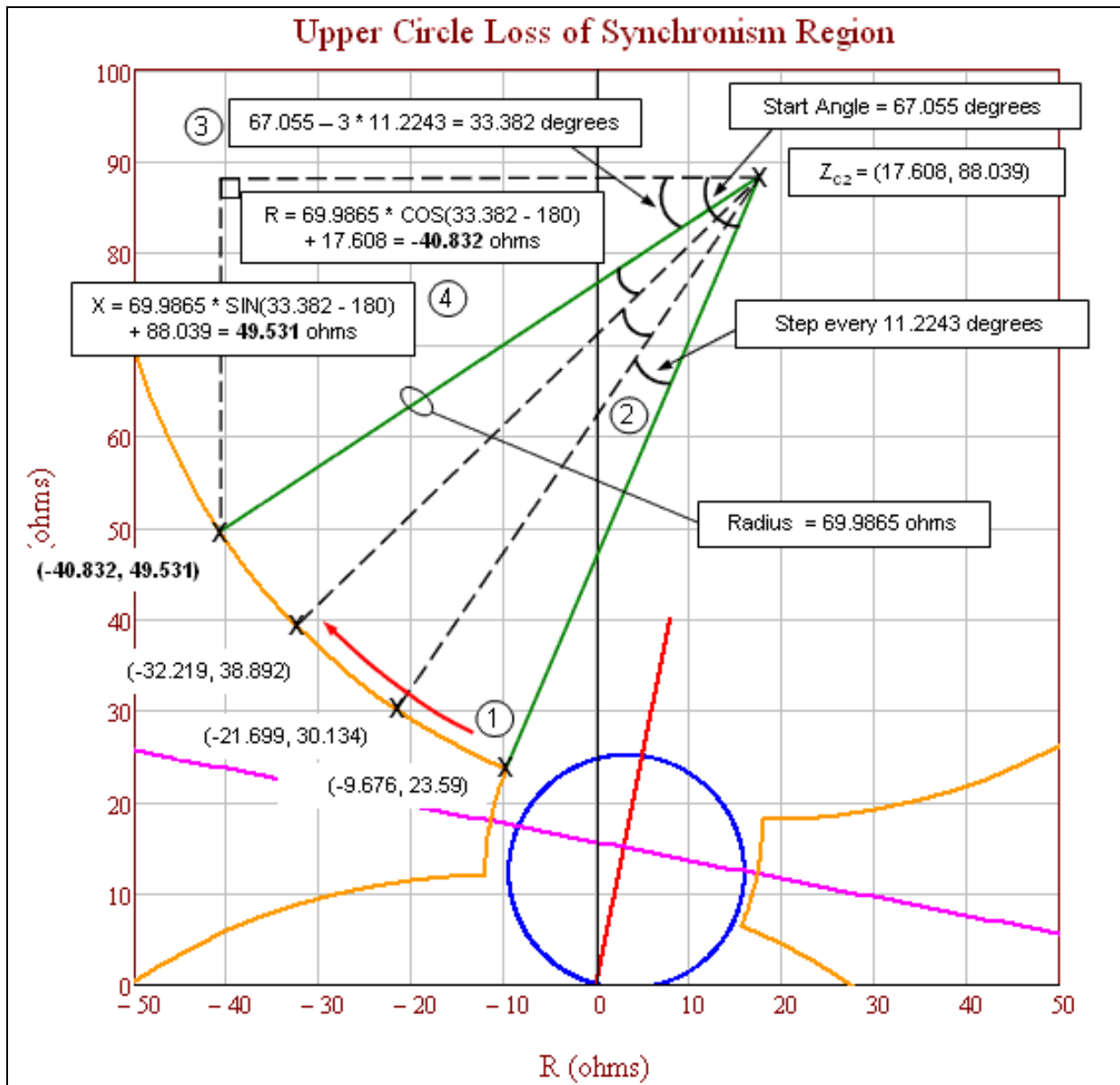






**Figure 15g:** Upper circle loss-of-synchronism region showing the steps to calculate the start angle, end angle, and the angle step size for the desired number of calculated points. 1) Calculate the system angle. 2) Calculate the start angle. 3) Calculate the end angle. 4) Calculate the angle step size for the desired number of points.





**Figure 15h:** Upper circle loss-of-synchronism region showing the final steps to calculate the coordinates of the points on the circle. 1) Start at the intersection with the lens shape and proceed in a clockwise direction. 2) Advance the step angle for each point. 3) Calculate the new angle after step advancement. 4) Calculate the R-X coordinates.

Lower Loss of Synchronism Circle Coordinates			Upper Loss of Synchronism Circle Coordinates		
Angle (degrees)	R	+ jX	Angle (degrees)	R	+ jX
67.055	15.676	6.41	67.055	-9.676	23.59
55.831	27.699	-0.134	55.831	-21.699	30.134
44.606	38.219	-8.892	44.606	-32.219	38.892
<b>33.382</b>	<b>46.832</b>	<b>-19.531</b>	<b>33.382</b>	<b>-40.832</b>	<b>49.531</b>
22.158	53.21	-31.643	22.158	-47.21	61.643
10.933	57.108	-44.765	10.933	-51.108	74.765
359.709	58.378	-58.395	359.709	-52.378	88.395
348.485	56.97	-72.011	348.485	-50.97	102.011
337.26	52.939	-85.092	337.26	-46.939	115.092
326.036	46.438	-97.139	326.036	-40.438	127.139
314.812	37.717	-107.69	314.812	-31.717	137.69
303.587	27.109	-116.341	303.587	-21.109	146.341
292.363	15.02	-122.762	292.363	-9.02	152.762
281.139	1.913	-126.707	281.139	4.087	156.707
269.914	-11.712	-128.026	269.914	17.712	158.026
258.69	-25.333	-126.667	258.69	31.333	156.667
247.466	-38.429	-122.682	247.466	44.429	152.682
236.241	-50.499	-116.225	236.241	56.499	146.225
225.017	-61.081	-107.542	225.017	67.081	137.542
213.793	-69.771	-96.965	213.793	75.771	126.965
202.568	-76.235	-84.899	202.568	82.235	114.899
191.344	-80.227	-71.806	191.344	86.227	101.806
180.12	-81.594	-58.185	180.12	87.594	88.185
168.895	-80.284	-44.56	168.895	86.284	74.56
157.671	-76.347	-31.45	157.671	82.347	61.45
146.447	-69.933	-19.357	146.447	75.933	49.357
135.222	-61.288	-8.744	135.222	67.288	38.744
123.998	-50.742	-0.016	123.998	56.742	30.016
112.774	-38.699	6.491	112.774	44.699	23.509
101.549	-25.62	10.53	101.549	31.62	19.47
90.325	-12.005	11.946	90.325	18.005	18.054

**Figure 15i:** Full tables of calculated lower and upper loss-of-synchronism circle coordinates. The highlighted row is the detailed calculated points in Figures 15d and 15h.

### Application Specific to ~~Criteria~~ **Criterion B**

The PRC-026-1 – Attachment B, ~~Criteria~~ **Criterion B** evaluates overcurrent elements used for tripping. The same criteria as PRC-026-1 – Attachment B, ~~Criteria~~ **Criterion A** is used except for an additional ~~criteria~~ **riterion** (No. 4) that calculates a current magnitude based upon generator ~~terminal voltages~~ **internal voltage** of 1.05 per unit. **A value of 1.05 per unit generator voltage is used to establish a minimum pickup current value for overcurrent relays that have a time delay less than 15 cycles. The formulas sending-end and receiving-end voltages are established at 1.05 per unit at 120 degree system separation angle. The 1.05 per unit is the typical upper end of the operating voltage, which is also consistent with the maximum power transfer calculation using actual system**

## PRC-026-1 – Application Guidelines

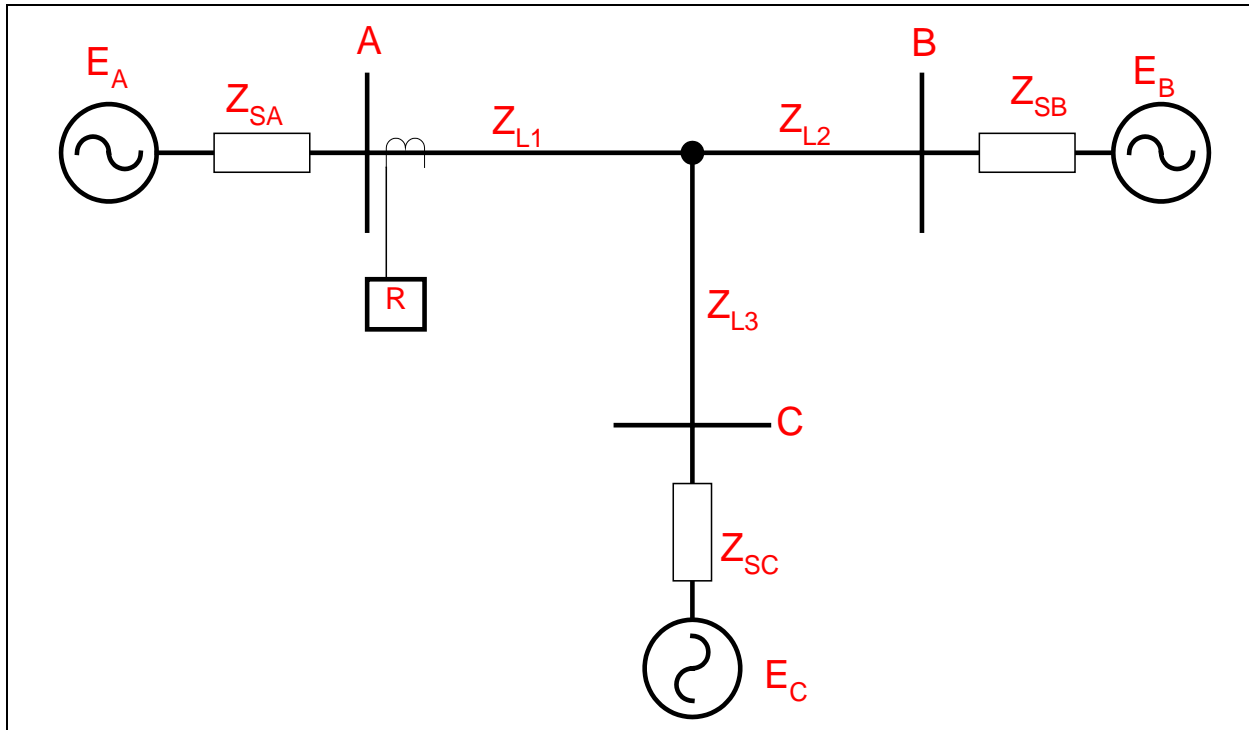
source impedances in the PRC-023 NERC Reliability Standard. The formulas used to calculate the current is as follows: are in Table 14 below.

Table 14: Example Calculation (Overcurrent)			
<p>This example is for a 230 kV line terminal with a directional instantaneous phase overcurrent element set to 50 amps secondary times a CT ratio of 160:1 that equals 8,000 amps, primary. The following calculation is where <math>V_S</math> equals the base line-to-ground sending-end generator source voltage times 1.05 at an angle of 120 degrees, <math>V_R</math> equals the base line-to-ground receiving-end generator <del>terminal</del>internal voltage times 1.05 at an angle of 0 degrees, and <math>Z_{sys}</math> equals the sum of the sending-end <u>source</u>, line, and receiving-end source impedances in ohms.</p> <p>Here, the <del>phase</del>instantaneous <u>phase</u> setting of 8,000 amps is greater than the calculated system current of 5,716 amps; therefore, it meets PRC-026-1 – Attachment B, <del>Criteria</del>Criterion B.</p>			
Eq. (102)	$V_S = \frac{V_{LL} \angle 120^\circ}{\sqrt{3}} \times 1.05$		
	$V_S = \frac{230,000 \angle 120^\circ V}{\sqrt{3}} \times 1.05$		
	$V_S = 139,430 \angle 120^\circ V$		
Receiving-end generator terminal voltage.			
Eq. (103)	$V_R = \frac{V_{LL} \angle 0^\circ}{\sqrt{3}} \times 1.05$		
	$V_R = \frac{230,000 \angle 0^\circ V}{\sqrt{3}} \times 1.05$		
	$V_R = 139,430 \angle 0^\circ V$		
<p>The total impedance of the system (<math>Z_{sys}</math>) equals the sum of the sending-end source impedance (<math>Z_S</math>), the impedance of the line (<math>Z_L</math>), and receiving-end impedance (<math>Z_R</math>) in ohms.</p>			
Given:	$Z_S = 3 + j26 \Omega$	$Z_L = 1.3 + j8.7 \Omega$	$Z_R = 0.3 + j7.3 \Omega$
Eq. (104)	$Z_{sys} = Z_S + Z_L + Z_R$		
	$Z_{sys} = (3 + j26) \Omega + (1.3 + j8.7) \Omega + (0.3 + j7.3) \Omega$		
	$Z_{sys} = 4.6 + j42 \Omega$		
Total system current <del>from sending-end source</del> .			
Eq. (105)	$I_{sys} = \frac{(V_S - V_R)}{Z_{sys}}$		
	$I_{sys} = \frac{(139,430 \angle 120^\circ V - 139,430 \angle 0^\circ V)}{(4.6 + j42) \Omega}$		
	$I_{sys} = 5,715.82 \angle 66.25^\circ A$		

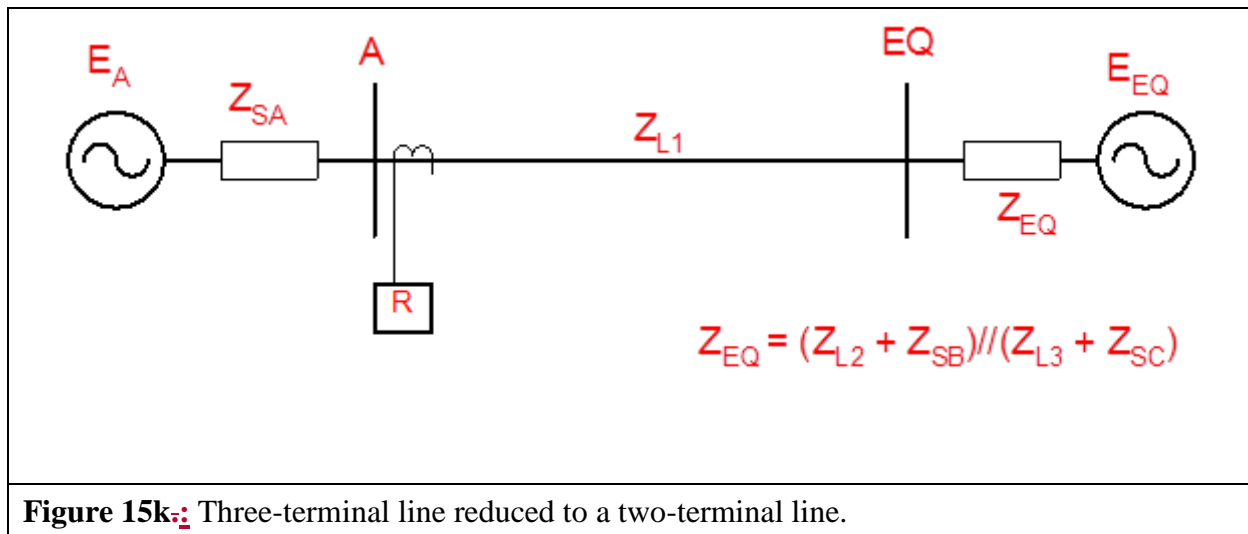
### Application Specific to Three-Terminal Lines

If a three-terminal line is identified as an Element that is susceptible to a power swing based on Requirement R1, the load-responsive protective relays at each end of the three-terminal line must be evaluated.

As shown in Figure 15j, the source impedances at each end of the line can be obtained from the similar short circuit calculation as for the two-terminal line- (assuming the parallel transfer impedances are ignored).



**Figure 15j:** Three-terminal line. To evaluate the load-responsive protective relays on the three-terminal line at Terminal A, the circuit in Figure 15j is first reduced to the equivalent circuit shown in Figure 15k. The evaluation process for the load-responsive protective relays on the line at Terminal A will now be the same as that of the two-terminal line.



**Figure 15k:** Three-terminal line reduced to a two-terminal line.

### Application to Generation Elements

As with transmission BES Elements, the determination of the apparent impedance seen at an Element located at, or near, a generation Facility is complex for power swings due to various interdependent quantities. These variances in quantities are caused by changes in machine internal voltage, speed governor action, voltage regulator action, the reaction of other local generators, and the reaction of other interconnected transmission BES Elements as the event progresses through the time domain. Though transient stability simulations may be used to determine the apparent impedance for verifying load-responsive relay settings,<sup>20,21</sup> Requirement R2, PRC-026-1 – Attachment B, Criteria A and B provides a simplified method for evaluating the load-responsive protective relay’s susceptibility to tripping in response to a stable power swing without requiring stability simulations.

In general, the electrical center will be in the transmission system for cases where the generator is connected through a weak transmission system (high external impedance). ~~Other~~In other cases where the generator is connected through a strong ~~Transmission~~transmission system, the electrical center could be inside the unit connected zone.<sup>22</sup> In either case, load-responsive protective relays connected at the generator terminals or at the high-voltage side of the generator step-up (GSU) transformer may be challenged by power swings ~~as~~. Relays that may be challenged by power swings will be determined by the Planning Coordinator in Requirement R1 or by the Generator Owner after becoming aware of a generator, transformer, or transmission line BES Element that tripped<sup>23</sup> in response to a stable or unstable power swing due to the operation of its protective relay(s) in Requirement R2.

<sup>20</sup> Donald Reimert, *Protective Relaying for Power Generation Systems*, Boca Raton, FL, CRC Press, 2006.

<sup>21</sup> Prabha Kundur, *Power System Stability and Control*, EPRI, McGraw Hill, Inc., 1994.

<sup>22</sup> Ibid, Kundur.

<sup>23</sup> See Guidelines and Technical Basis section, “Becoming Aware of an Element That Tripped in Response to a Power Swing,”

## PRC-026-1 – Application Guidelines

---

~~Load-responsive protective relays such as time-over-current, voltage~~ Voltage controlled time-overcurrent ~~or~~ and voltage-restrained time-overcurrent relays are excluded from this standard ~~if they. When these relays~~ are set based on equipment permissible overload capability. ~~Their, their~~ operating ~~time is~~ times are much greater than 15 cycles for the current levels observed during a power swing.

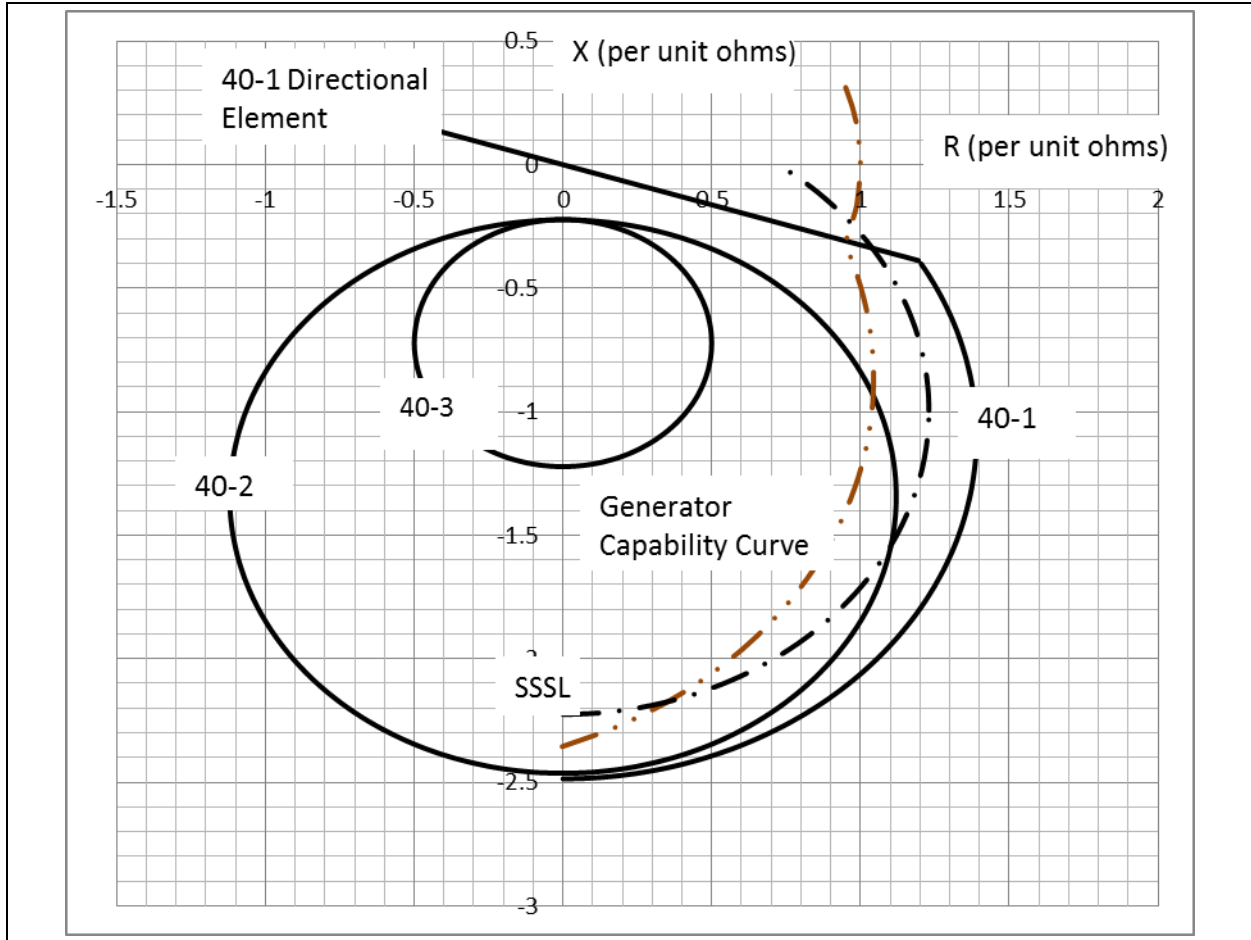
Instantaneous overcurrent, time-overcurrent, and definite-time overcurrent relays with a time delay of less than 15 cycles for the current levels observed during a power swing are applicable and are required to be evaluated for identified Elements.

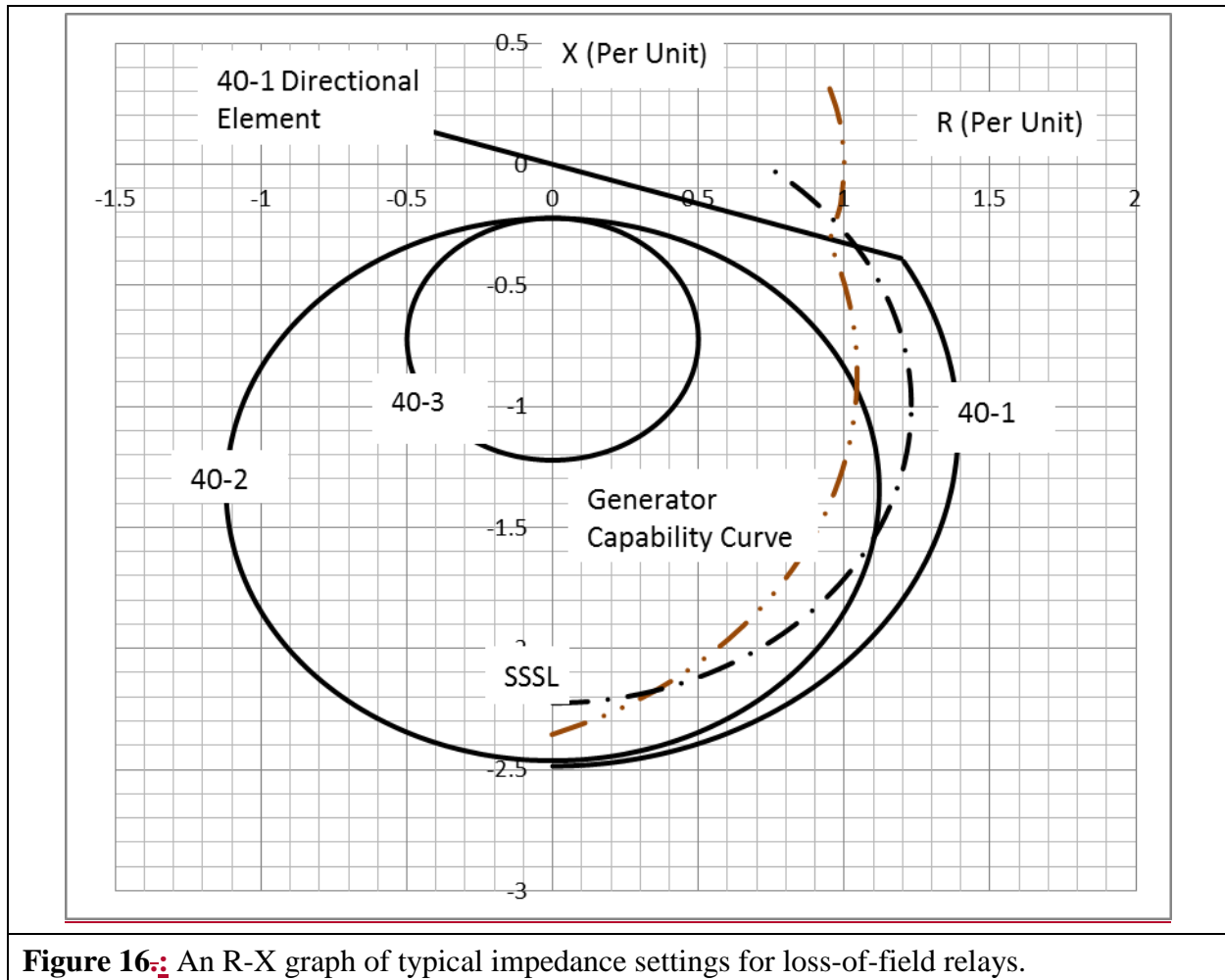
The generator loss-of-field protective function is provided by impedance relay(s) connected at the generator terminals. The settings are applied to protect the generator from a partial or complete loss of excitation under all generator loading conditions and, at the same time, be immune to tripping on stable power swings. It is more likely that the loss-of-field relay would operate during a power swing when the automatic voltage regulator (AVR) is in manual mode rather than when in automatic mode.<sup>24</sup> Figure 16 illustrates the loss-of-field relay in the R-X plot, which typically includes up to three zones of protection.

---

<sup>24</sup> John Burdy, *Loss-of-excitation Protection for Synchronous Generators GER-3183*, General Electric Company.







**Figure 16:** An R-X graph of typical impedance settings for loss-of-field relays.

Loss-of-field characteristic 40-1 has a wider impedance characteristic (positive offset) than characteristic 40-2 or characteristic 40-3 and provides additional generator protection for a partial loss of field or a loss of field under low load (less than 10% of rated). The tripping logic of this protection scheme is established by a directional contact, a voltage setpoint, and a time delay. The voltage and time delay add security to the relay operation for stable power swings. Characteristic 40-3 is less sensitive to power swings than characteristic 40-2 and is set outside the generator capability curve in the leading direction. Regardless of the relay impedance setting, PRC-019<sup>25</sup> requires that the “in-service limiters operate before Protection Systems to avoid unnecessary trip” and “in-service Protection System devices are set to isolate or de-energize equipment in order to limit the extent of damage when operating conditions exceed equipment capabilities or stability limits.” Time delays for tripping associated with loss-of-field relays<sup>26,27</sup> have a range from 15 cycles for characteristic 40-2 to 60 cycles for characteristic 40-1 to minimize tripping during stable

<sup>25</sup> Coordination of Generating Unit or Plant Capabilities, Voltage Regulating Controls, and Protection

<sup>26</sup> Ibid, Burdy.

<sup>27</sup> *Applied Protective Relaying*, Westinghouse Electric Corporation, 1979.

power swings. In ~~the standard~~ PRC-026-1, 15 cycles establishes a threshold for applicability; however, it is the responsibility of the Generator Owner to establish settings that provide security against stable power swings and, at the same time, dependable protection for the generator.

The simple two-machine system circuit (method also used in the Application to Transmission Elements section) is used to analyze the effect of a power swing at a generator facility for load-responsive relays. In this section, the calculation method is used for calculating the impedance seen by the relay connected at a point in the circuit.<sup>28</sup> The electrical quantities used to determine the apparent impedance plot using this method are generator saturated transient reactance ( $X'_d$ ), GSU transformer impedance ( $X_{GSU}$ ), transmission line impedance ( $Z_L$ ), and the system equivalent ( $Z_e$ ) at the point of interconnection. All impedance values are known to the Generator Owner except for the system equivalent. The system equivalent is obtainable from the Transmission Owner. The sending-end and receiving-end source voltages are varied from 0.0 to 1.0 per unit to form the lens shape portion of the unstable power swing region. The voltage range of 0.7 to 1.0 results in a ratio range from 0.7 to 1.43. This ratio range is used to form the lower and upper loss-of-synchronism circle shapes of the unstable power swing region. A system separation angle of 120 degrees is used in accordance with PRC-026-1 – Attachment B criteria for each load-responsive protective relay evaluation.

Table 15 below is an example calculation of the apparent impedance locus method based on Figures 17 and 18.<sup>29</sup> In this example, the generator is connected to the 345 kV transmission system through the GSU transformer and has the listed ratings. Note that the load-responsive protective relays in this example may have ownership with the Generator Owner or the Transmission Owner.

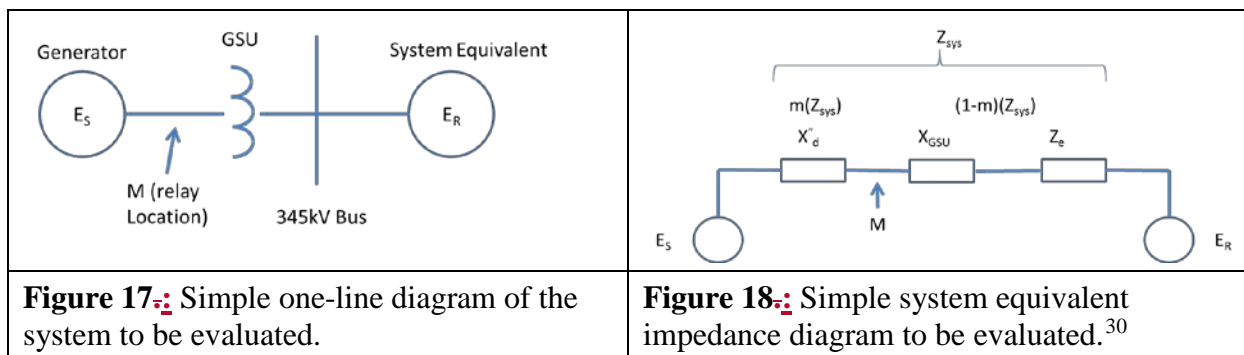


Table 15: Example Data (Generator)	
Input Descriptions	Input Values
Synchronous Generator nameplate (MVA)	940 MVA

<sup>28</sup> Edward Wilson Kimbark, *Power System Stability, Volume II: Power Circuit Breakers and Protective Relays*, Published by John Wiley and Sons, 1950.

<sup>29</sup> Ibid, Kimbark.

<sup>30</sup> Ibid, Kimbark.

Table 15: Example Data (Generator)	
Sub-Saturated transient reactance (940 MVA base)	$X'_d = 0.3845$ (per unit)
Generator rated voltage (Line-to-Line)	20 kV
Generator step-up (GSU) transformer rating	880 MVA
GSU transformer reactance (880 MVA base)	$X_{GSU} = 16.05\%$
System Equivalent (100 MVA base)	$Z_e = 0.00723 \angle 86^\circ$ <del>ohms</del> <span style="color: red;">90° per unit</span>
Generator Owner Load-Responsive Protective Relays	
40-1	Positive Offset Impedance
	Offset = 0.294 per unit <del>ohms</del> <span style="color: red;">ohms</span>
	Diameter = 0.294 per unit <del>ohms</del> <span style="color: red;">ohms</span>
40-2	Negative Offset Impedance
	Offset = 0.22 per unit <del>ohms</del> <span style="color: red;">ohms</span>
	Diameter = 2.24 per unit <del>ohms</del> <span style="color: red;">ohms</span>
40-3	Negative Offset Impedance
	Offset = 0.22 per unit <del>ohms</del> <span style="color: red;">ohms</span>
	Diameter = 1.00 per unit <del>ohms</del> <span style="color: red;">ohms</span>
21-1	Diameter = 0.643 per unit <del>ohms</del> <span style="color: red;">ohms</span>
	MTA = 85°
50	I (pickup) = 5.0 per unit
Transmission Owned Load-Responsive Protective Relays	
21-2	Diameter = 0.55 per unit <del>ohms</del> <span style="color: red;">ohms</span>
	MTA = 85°

Calculations shown for a 120 degree angle and  $E_S/E_R = 1$ . The equation for calculating  $Z_R$  is:<sup>31</sup>

$$\text{Eq. (106)} \quad Z_R = \left( \frac{(1 - m)(E_S \angle \delta) + (m)(E_R)}{E_S \angle \delta - E_R} \right) \times Z_{sys}$$

<sup>31</sup> Ibid, Kimbark.

## PRC-026-1 – Application Guidelines

Where  $m$  is the relay location as a function of the total impedance (real number less than 1)

$E_S$  and  $E_R$  is the sending-end and receiving-end voltages

$Z_{sys}$  is the total system impedance

$Z_R$  is the complex impedance at the relay location and plotted on an R-X diagram

All of the above are constants (940 MVA base) while the angle  $\delta$  is varied. Table 16 below contains calculations for a generator using the data listed in Table 15.

Table 16: Example Calculations (Generator)			
The following calculations are on a 940 MVA base.			
Given:	$X'_d = j0.3845 \Omega pu$	$X_{GSU} = j0.171 \Omega + 0.17144 pu$	$Z_e = 0j0.06796 \Omega pu$
Eq. (107)	$Z_{sys} = X'_d + X_{GSU} + Z_e$		
	$Z_{sys} = j0.3845 \Omega pu + j0.171 \Omega + 0.17144 pu + j0.06796 \Omega pu$		
	$Z_{sys} = 0.6239 \angle 90^\circ \Omega pu$		
Eq. (108)	$m = \frac{X'_d}{Z_{sys}} = \frac{0.3845}{0.6239} = 0.616336163$		
Eq. (109)	$Z_R = \left( \frac{(1-m)(E_S \angle \delta) + (m)(E_R)}{E_S \angle \delta - E_R} \right) \times Z_{sys}$		
	$Z_R = \left( \frac{(1-0.61633) \times (1 \angle 120^\circ) + (0.61633)(1 \angle 0^\circ)}{1 \angle 120^\circ - 1 \angle 0^\circ} \right) \times (0.6234 \angle 90^\circ) \Omega Z_R$ $= \left( \frac{(1-0.6163) \times (1 \angle 120^\circ) + (0.6163)(1 \angle 0^\circ)}{1 \angle 120^\circ - 1 \angle 0^\circ} \right) \times (0.6239 \angle 90^\circ) pu$		
	$Z_R = \left( \frac{0.4244 + j0.3323}{-1.5 + j0.866} \right) \times (0.6234 \angle 90^\circ)(0.6239 \angle 90^\circ) \Omega pu$		
	$Z_R = (0.3112 \angle -111.94^\circ)(0.3116 \angle -111.95^\circ) \times (0.6234 \angle 90^\circ)(0.6239 \angle 90^\circ) \Omega pu$		
	$Z_R = 0.194 \angle -21.94^\circ \Omega 95^\circ pu$		
	$Z_R = -0.18 - j0.073 \Omega pu$		

Table 17 lists the swing impedance values at other angles and at  $E_S/E_R = 1, 1.43,$  and  $0.7$ . The impedance values are plotted on an R-X graph with the center being at the generator terminals for use in evaluating impedance relay settings.

**Table 17: Sample calculations for a swing impedance chart for varying voltages at the sending-end and receiving-end.**

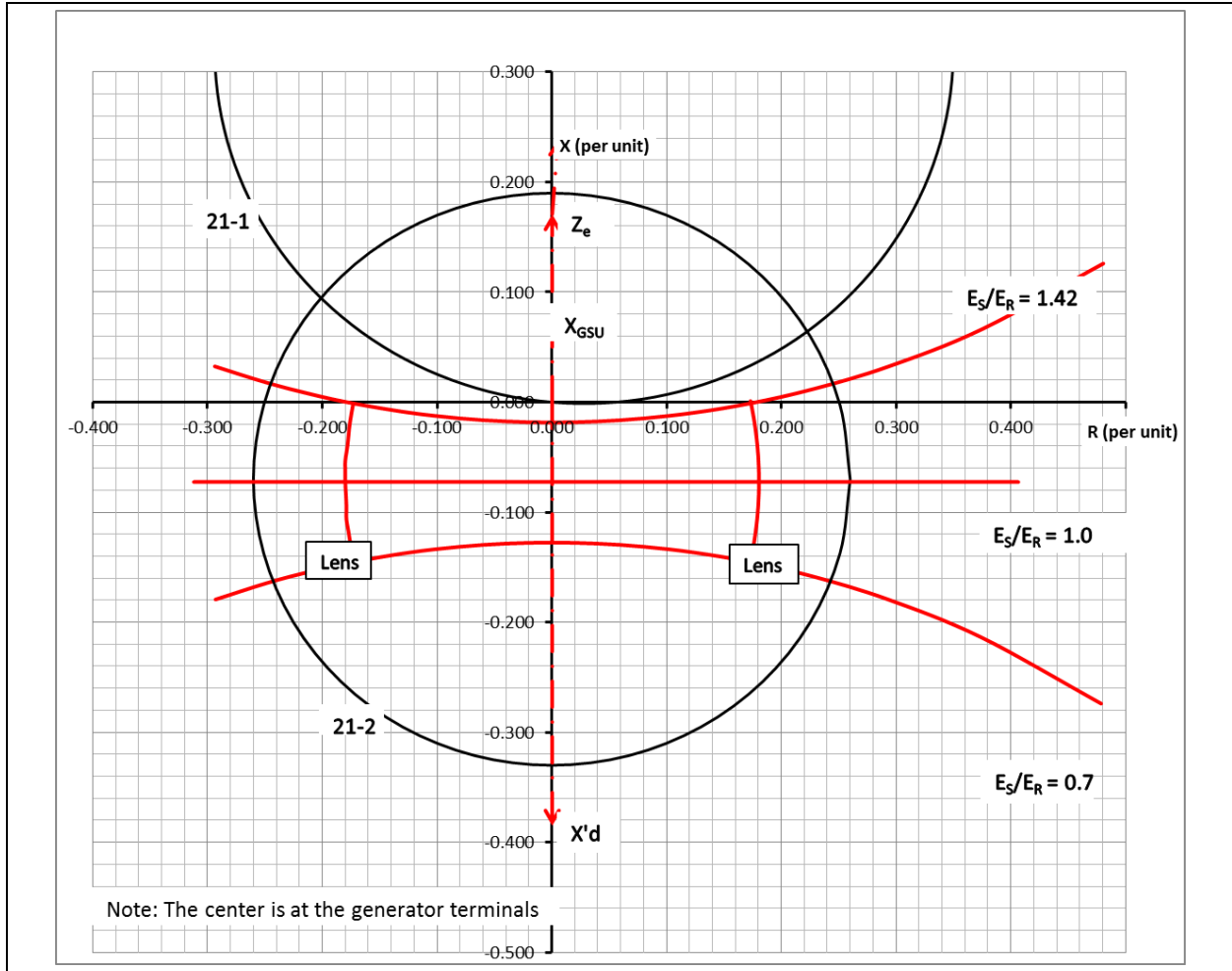
Angle ( $\delta$ ) (Degrees)	$E_S/E_R=1$		$E_S/E_R=1.43$		$E_S/E_R=0.7$	
	$Z_R$		$Z_R$		$Z_R$	
	Magnitude ( $\text{PU}$ $\text{Ohms/PU}$ )	Angle (Degrees)	Magnitude ( $\text{PU}$ $\text{Ohms/PU}$ )	Angle (Degrees)	Magnitude ( $\text{PU}$ $\text{Ohms/PU}$ )	Angle (Degrees)
90	0.320	-13.1	0.296	6.3	0.344	-31.5
120	0.194	-21.9	0.173	-0.4	0.227	-40.1
150	0.111	-41.0	0.082	-10.3	0.154	-58.4
210	0.111	-25.9	0.082	190.3	0.154	238.4
240	0.194	201.9	0.173	180.4	0.225	220.1
270	0.320	193.1	0.296	173.7	0.344	211.5

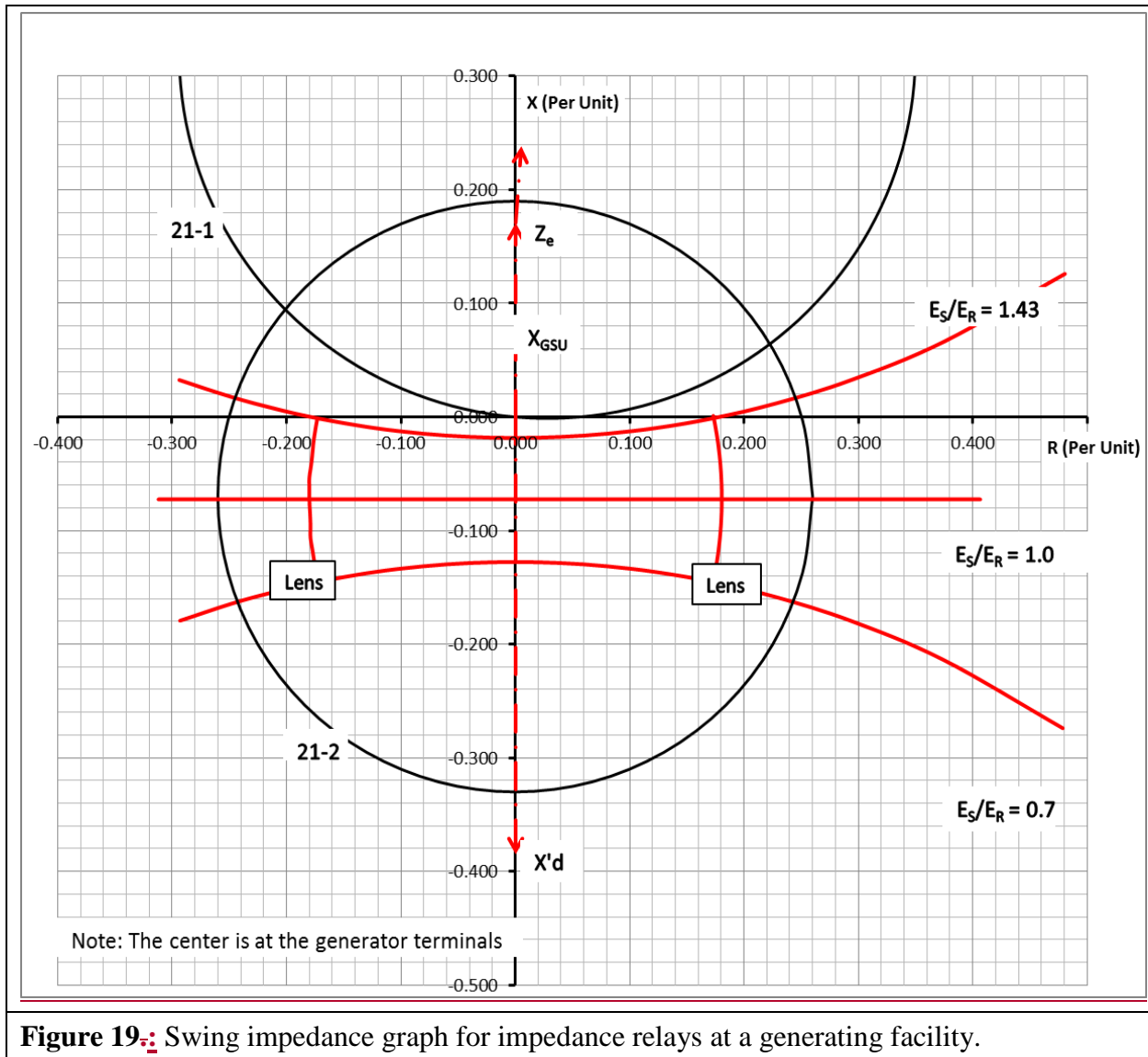
## Requirement R2 Generator Examples

### Distance Relay Application

Based on PRC-026-1 – Attachment B, ~~Criteria~~ Criterion A, the distance relay (21-1) (i.e., owned by the Generation Owner) characteristic is in the region where a stable power swing would not occur as shown in Figure 19. There is no further obligation to the owner in this standard for this load-responsive protective relay.

The distance relay (21-2) (i.e., owned by the Transmission Owner) is connected at the high-voltage side of the GSU transformer and its impedance characteristic is in the region where a stable power swing could occur causing the relay to operate. In this example, if the intentional time delay of this relay is less than 15 cycles, the PRC-026 – Attachment B, ~~Criteria B~~ Criterion A cannot be met, thus the Transmission Owner is required to create a CAP (Requirement R3). Some of the options include, but are not limited to, changing the relay setting (i.e., impedance reach, angle, time delay), modify the scheme (i.e., add PSB), or replace the Protection System. Note that the relay may be excluded from this standard if it has an intentional time delay equal to or greater than 15 cycles.





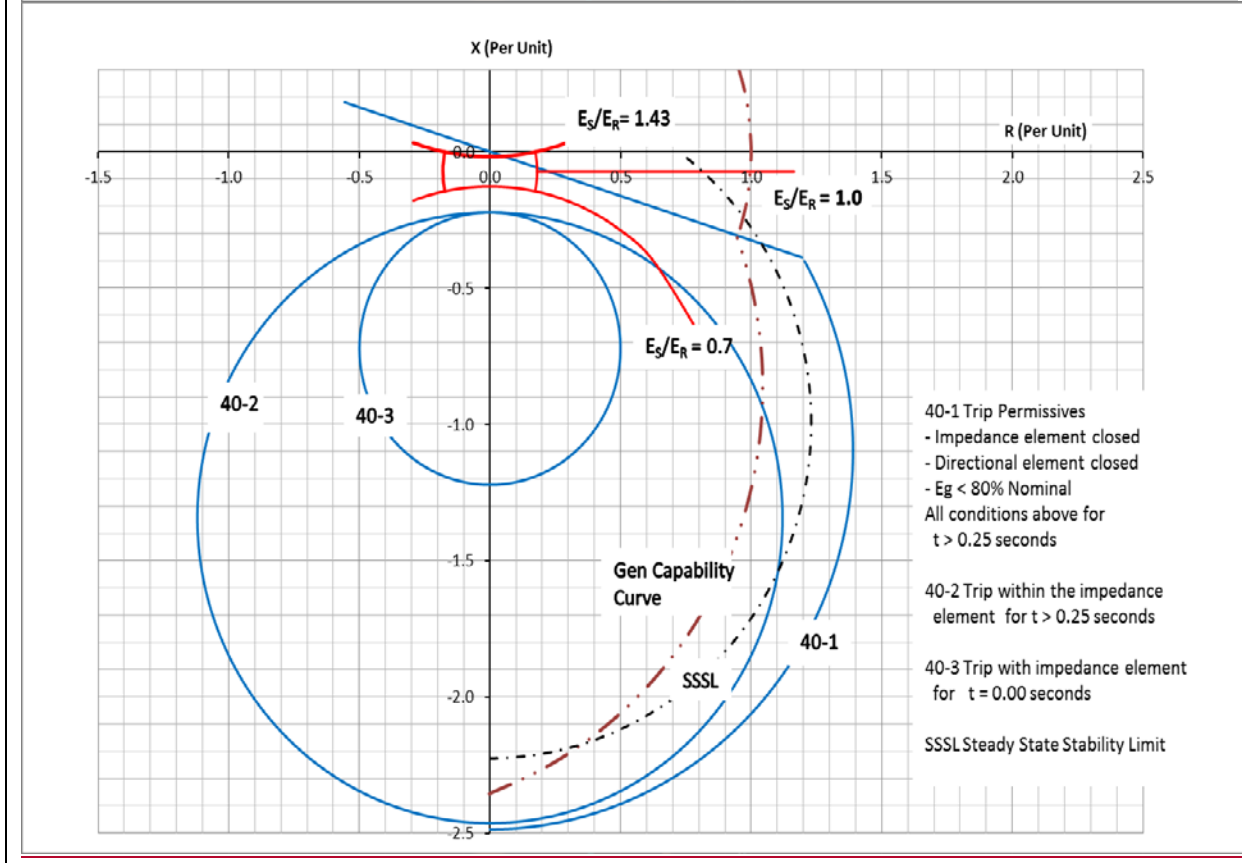
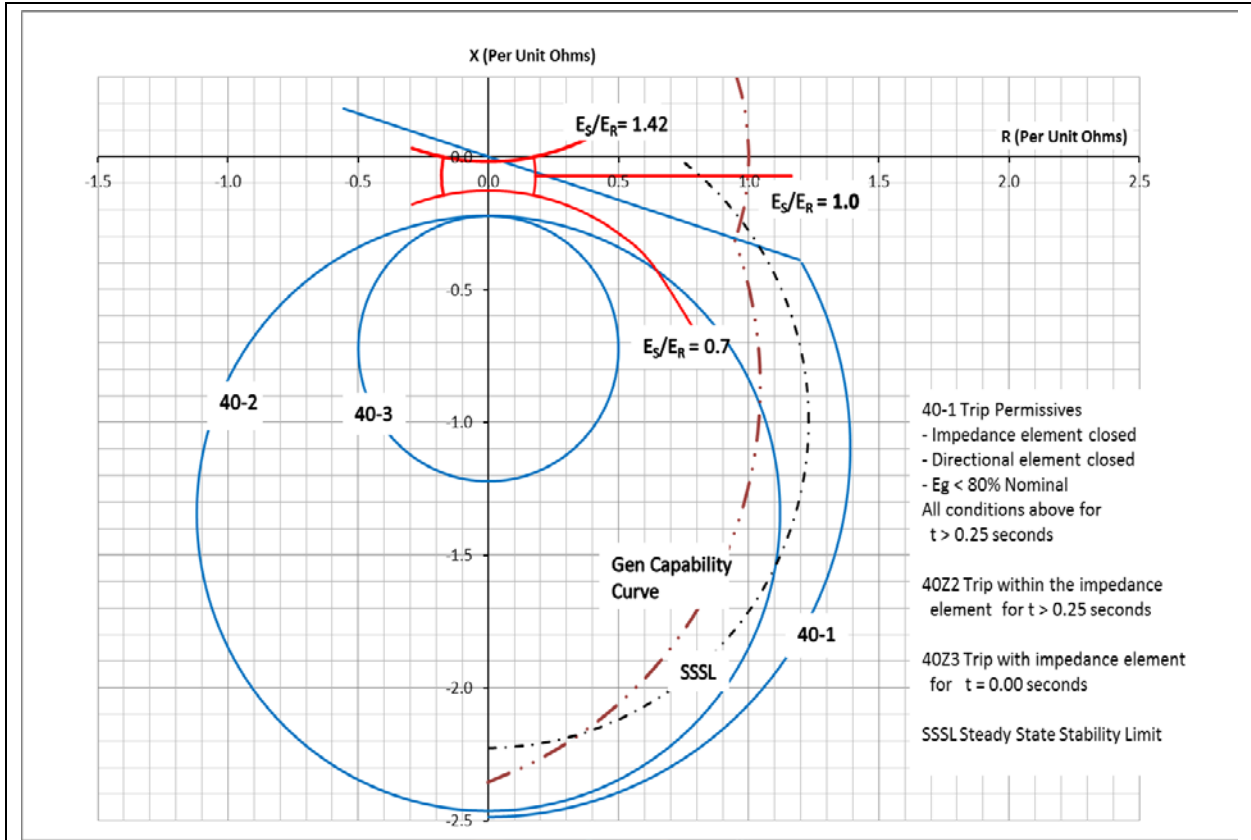
**Figure 19:** Swing impedance graph for impedance relays at a generating facility.

### Loss-of-Field Relay Application

In Figure 20, the R-X diagram shows the loss-of-field relay (40-1 and 40-2) characteristics are in the region where a stable power swing can cause a relay operation. Protective relay 40-1 would be excluded if it has an intentional time delay equal to or greater than 15 cycles. Similarly, 40-2 would be excluded if its intentional time delay is equal to or greater than 15 cycles. For example, if 40-1 has a time delay of 1 second and 40-2 has a time delay of 0.25 seconds, they are excluded and there is no further obligation on the Generator Owner in this standard for these relays. The loss-of-field relay characteristic 40-3 is outside entirely inside the region where a stable unstable power swing can cause a relay operation region. In this case, the owner may select high speed tripping on operation of the 40-3 impedance element.



# PRC-026-1 – Application Guidelines



**Figure 20: ~~Stable power swing~~ Typical R-X graph for loss-of-field relays with a portion of the unstable power swing region defined by PRC-026-1 – Attachment B, Criterion A.**

### Instantaneous Overcurrent Relay

In similar fashion to the transmission line overcurrent example calculation in Table 14, the instantaneous overcurrent relay minimum setting is established by PRC-026-1 – Attachment B, ~~Criteria~~Criterion B. The solution is found by:

$$\text{Eq. (110)} \quad I_{sys} = \frac{E_S - E_R}{Z_{sys}}$$

As stated in the relay settings in Table 15, the relay is installed on the high-voltage side of the GSU transformer with a pickup of 5.0 per unit ~~amps~~. The maximum allowable current is calculated below.

$$I_{sys} = \frac{(1.05 \angle 120^\circ - 1.05 \angle 0^\circ)}{0.6234 \angle 90^\circ} \frac{(1.05 \angle 120^\circ - 1.05 \angle 0^\circ)}{0.6239 \angle 90^\circ} \text{Apu}$$

$$I_{sys} = \frac{1.775 \angle 150^\circ \text{V}}{0.6234 \angle 90^\circ \Omega} \frac{1.819 \angle 150^\circ}{0.6239 \angle 90^\circ} \text{pu}$$

$$I_{sys} = 2.8491 \angle 60^\circ \text{Apu}$$

The ~~phase~~-instantaneous phase setting of 5.0 per unit ~~amps~~ is greater than the calculated system current of 2.8491 per unit ~~amps~~; therefore, it meets the PRC-026-1 – Attachment B, ~~Criteria~~Criterion B.

### Out-of-Step Tripping for Generation Facilities

Out-of-step protection for the generator generally falls into three different schemes. The first scheme is a distance relay connected at the high-voltage side of the GSU transformer with the directional element looking toward the generator. Because this relay setting may be the same setting used for generator backup protection (see Requirement R2 Generator Examples, Distance Relay Application), it is susceptible to tripping in response to stable power swings and would require modification. Because this scheme is susceptible to tripping in response to stable power swings and any modification to the mho circle will jeopardize the overall protection of the out-of-step protection of the generator, available technical literature does not recommend using this scheme specifically for generator out-of-step protection. The second and third out-of-step Protection System schemes are commonly referred to as single and double blinder schemes. These schemes are installed or enabled for out-of-step protection using a combination of blinders, a mho element, and timers. The combination of these protective relay functions provides out-of-step protection and discrimination logic for stable and unstable power swings. Single blinder schemes use logic that discriminate between stable and unstable power swings by issuing a trip command after the first slip cycle. Double blinder schemes are more complex ~~than~~ the single blinder scheme and, depending on the settings of the inner blinder, a trip for a

stable power swing may occur. While the logic discriminates between stable and unstable power swings in either scheme, it is important that the trip initiating blinders be set at an angle greater than the stability limit of 120 degrees to remove the possibility of a trip for a stable power swing. Below is a discussion of the double blinder scheme.

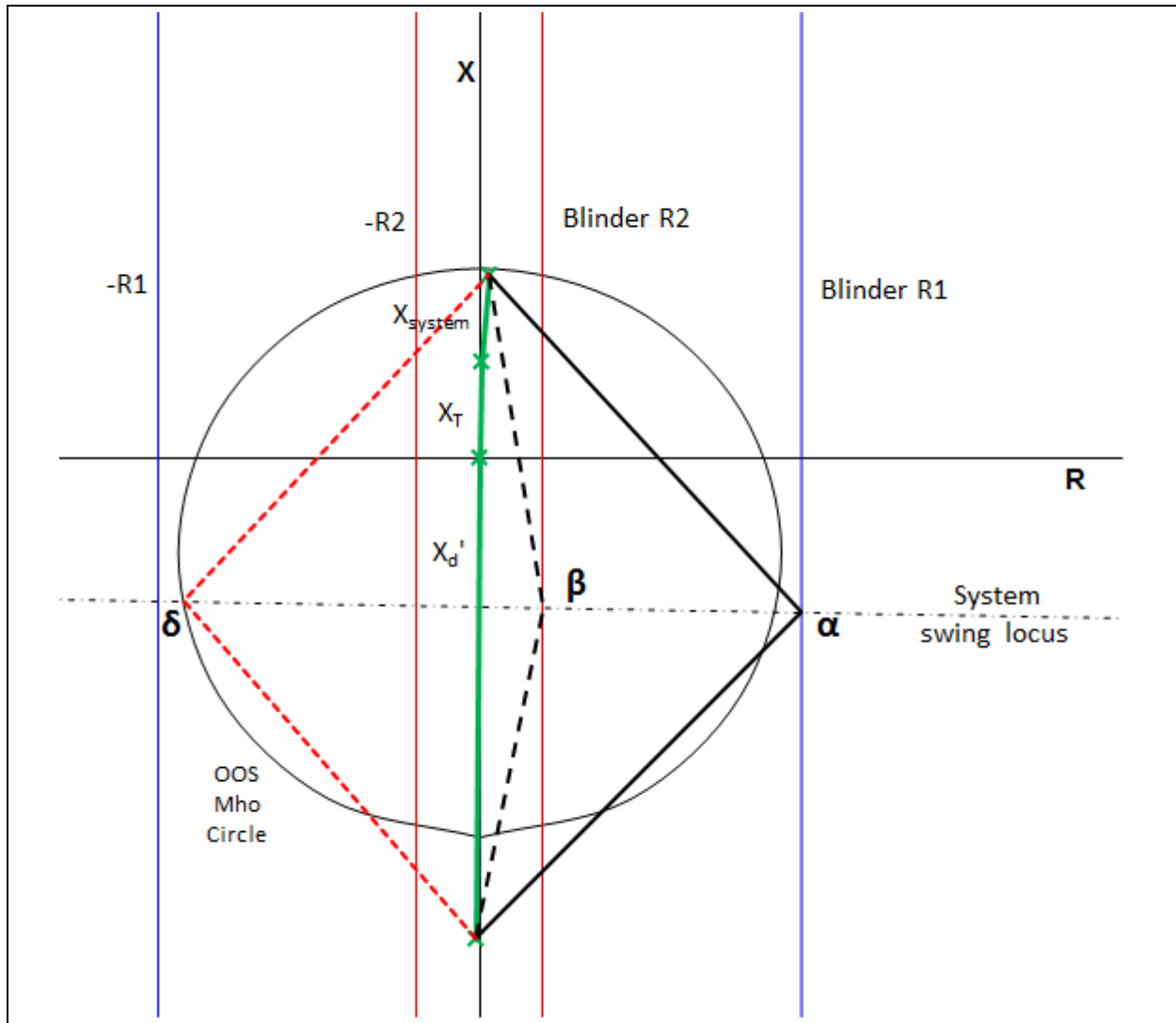
### ***Double Blinder Scheme***

The double blinder scheme is a method for measuring the rate of change of positive sequence impedance for out-of-step swing detection. The scheme compares a timer setting to the actual elapsed time required by the impedance locus to pass between two impedance characteristics. In this case, the two impedance characteristics are simple blinders, each set to a specific resistive reach on the R-X plane. Typically, the two blinders on the left half plane are the mirror images of those on the right half plane. The scheme typically includes a mho characteristic which acts as a starting element, but is not a tripping element.

The scheme detects the blinder crossings and time delays as represented on the R-X plane as shown in Figure 21. The system impedance is composed of the generator transient ( $X_d'$ ), GSU transformer ( $X_T$ ), and transmission system ( $X_{\text{system}}$ ), impedances.

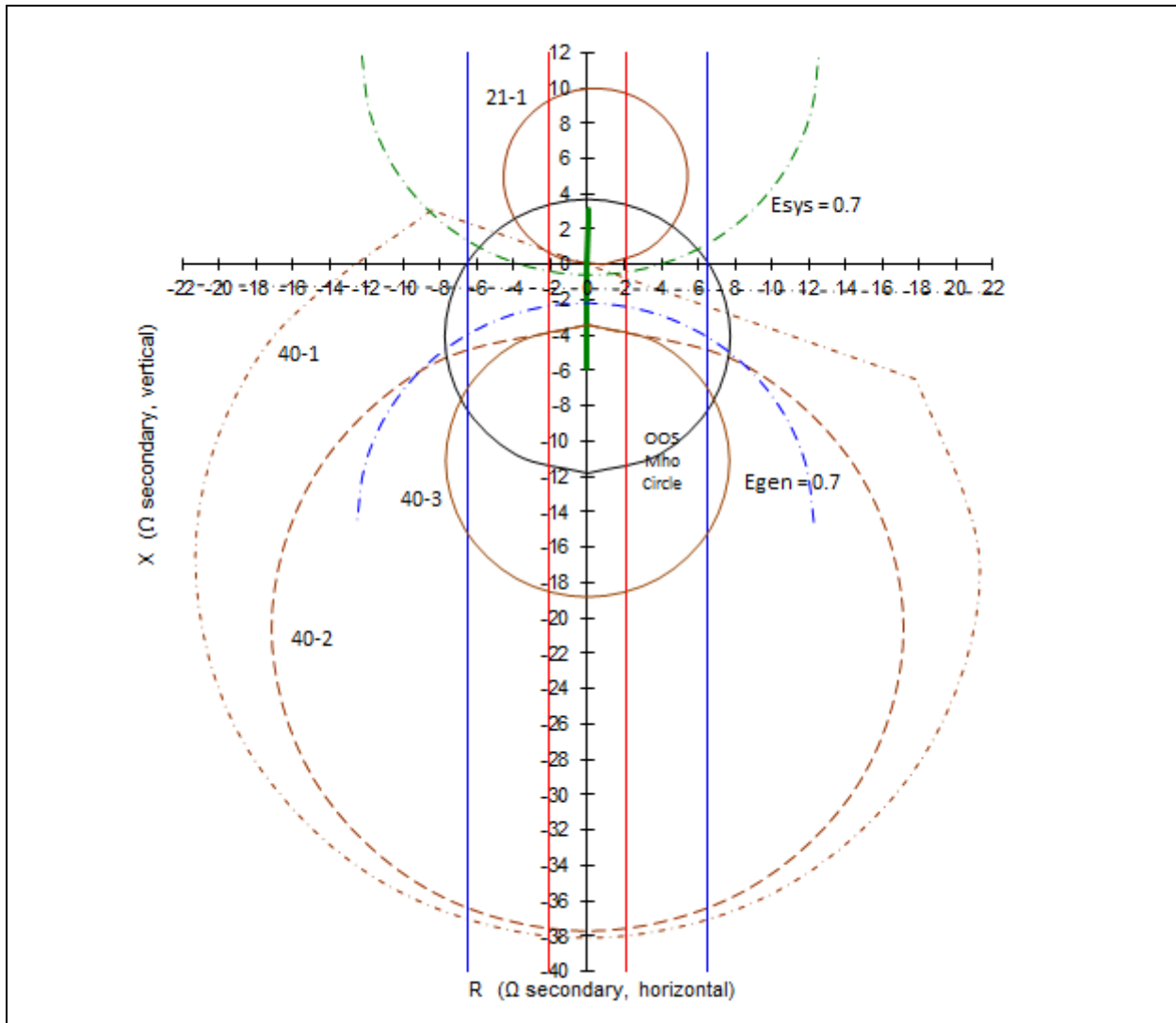
The scheme logic is initiated when the swing locus crosses the outer Blinder R1 (Figure 21), on the right at separation angle  $\alpha$ . The scheme only commits to take action when a swing crosses the inner blinder. At this point the scheme logic seals in the out-of-step trip logic at separation angle  $\beta$ . Tripping actually asserts as the impedance locus leaves the scheme characteristic at separation angle  $\delta$ .

The power swing may leave both inner and outer blinders in either direction, and tripping will assert. Therefore, the inner blinder must be set such that the separation angle  $\beta$  is large enough that the system cannot recover. This angle should be set at 120 degrees or more. Setting the angle greater than 120 degrees satisfies the PRC-026-1 – Attachment B ~~Criteria, Criterion~~ A (No. 1, 1<sup>st</sup> bullet) since the tripping function is asserted by the blinder element. Transient stability studies ~~are usually required to determine an appropriate inner blinder setting. Such studies~~ may indicate that a smaller stability limit angle is acceptable under PRC-026-1 – Attachment B ~~Criteria,~~ Criterion A (No. 1, 2<sup>nd</sup> bullet). In this respect, the double blinder scheme is similar to the double lens and triple lens schemes, and many transmission application out-of-step schemes.



**Figure 21:** Double Blinder Scheme generic out of step characteristics.

Figure 22 illustrates a sample setting of the double blinder scheme for the example 940 MVA generator. The only setting requirement for this relay scheme is the right inner blinder, which must be set greater than the separation angle of 120 degrees (or a lesser angle based on a transient stability study) to ensure that the out-of-step protective function is expected to not trip in response to a stable power swing during non-Fault conditions. Other settings such as the mho characteristic, outer blinders, and timers are set according to transient stability studies and are not a part of this standard.



**Figure 22:** Double Blinder Out-of-Step Scheme with unit impedance data and load-responsive protective relay impedance characteristics for the example 940 MVA generator, scaled in relay secondary ohms.

### Requirement R3

To achieve the stated purpose of this standard, which is to ensure that relays are expected to not trip in response to stable power swings during non-Fault conditions, this Requirement ensures that the applicable entity develops a Corrective Action Plan (CAP) that reduces the risk of relays tripping in response to a stable power swing during non-Fault conditions that may occur on any applicable BES Element.

### Requirement R4

To achieve the stated purpose of this standard, which is to ensure that load-responsive protective relays are expected to not trip in response to stable power swings during non-Fault conditions, the applicable entity is required to implement any CAP developed pursuant to Requirement R3 such that the Protection System will meet PRC-026-1 – Attachment B criteria or can be excluded under the PRC-026-1 – Attachment A criteria (e.g., modifying the Protection System so that relay functions are supervised by power swing blocking or using relay systems that are immune to power swings), while maintaining dependable fault detection and dependable out-of-step tripping (if out-of-step tripping is applied at the terminal of the BES Element). Protection System owners are required in the implementation of a CAP to update it when actions or timetable change, until all actions are complete. Accomplishing this objective is intended to reduce the occurrence of Protection System tripping during a stable power swing, thereby improving reliability and minimizing risk to the BES.

The following are examples of actions taken to complete CAPs for a relay that did not meet PRC-026-1 – Attachment B and could be at-risk of tripping in response to a stable power swing during non-Fault conditions. A Protection System change was determined to be acceptable (without diminishing the ability of the relay to protect for faults within its zone of protection).

**Example R4a:** Actions: Settings were issued on 6/02/2015 to reduce the Zone 2 reach of the impedance relay used in the directional comparison unblocking (DCUB) scheme from 30 ohms to 25 ohms so that the relay characteristic is completely contained within the lens characteristic identified by the criterion. The settings were applied to the relay on 6/25/2015. CAP was completed on 06/25/2015.

**Example R4b:** Actions: Settings were issued on 6/02/2015 to enable out-of-step blocking on the existing microprocessor-based relay to prevent tripping in response to stable power swings. The setting changes were applied to the relay on 6/25/2015. CAP was completed on 06/25/2015.

The following is an example of actions taken to complete a CAP for a relay responding to a stable power swing that required the addition of an electromechanical power swing blocking relay.

**Example R4c:** Actions: A project for the addition of an electromechanical power swing blocking relay to supervise the Zone 2 impedance relay was initiated on 6/5/2015 to prevent tripping in response to stable power swings. The relay installation was completed on 9/25/2015. CAP was completed on 9/25/2015.

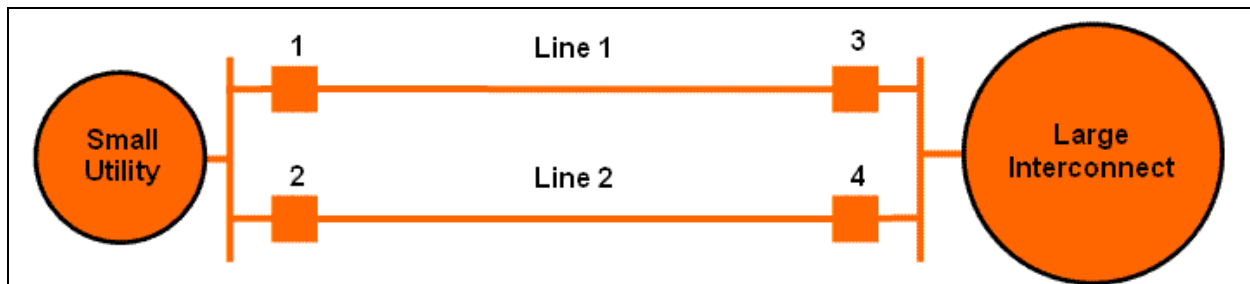
The following is an example of actions taken to complete a CAP with a timetable that required updating for the replacement of the relay.

**Example R4d:** Actions: A project for the replacement of the impedance relays at both terminals of line X with line current differential relays was initiated on 6/5/2015 to prevent tripping in response to stable power swings. The completion of the project was postponed due to line outage rescheduling from 11/15/2015 to 3/15/2016. Following the timetable change, the impedance relay replacement was completed on 3/18/2016. CAP was completed on 3/18/2016.

The CAP is complete when all the documented actions to remedy the specific problem (i.e., unnecessary tripping during stable power swings) are completed.

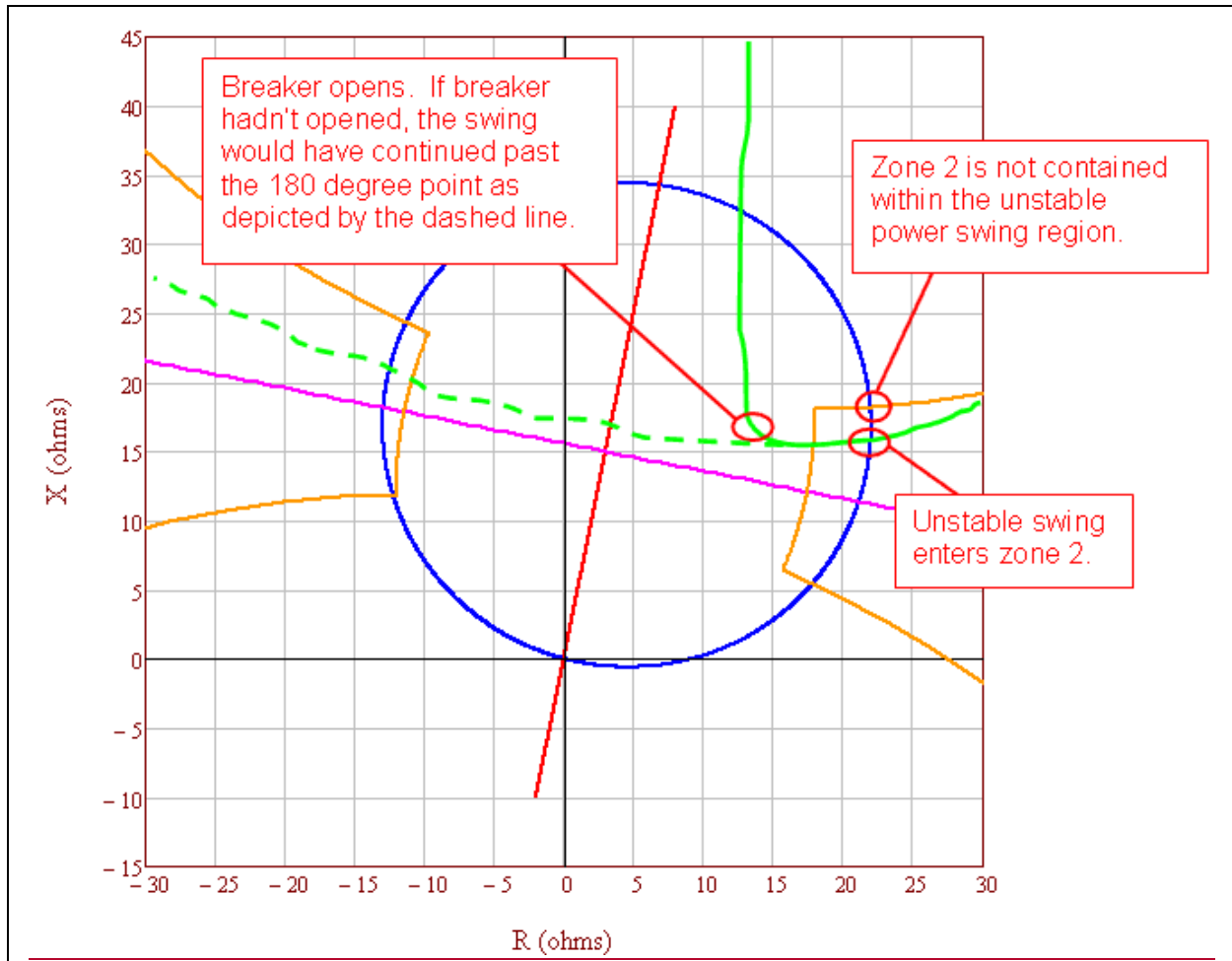
## Justification for Including Unstable Power Swings in the Requirements

Protection Systems that are applicable to the Standard and must be secure for a stable power swing condition (i.e., meets PRC-026-1 – Attachment B criteria) are identified based on Elements that are susceptible to both stable and unstable power swings. This section provides an example of why Elements that trip in response to unstable power swings (in addition to stable power swings) are identified and that their load-responsive protective relays need to be evaluated under PRC-026-1 – Attachment B criteria.



**Figure 23:** A simple electrical system where two lines tie a small utility to a much larger interconnection.

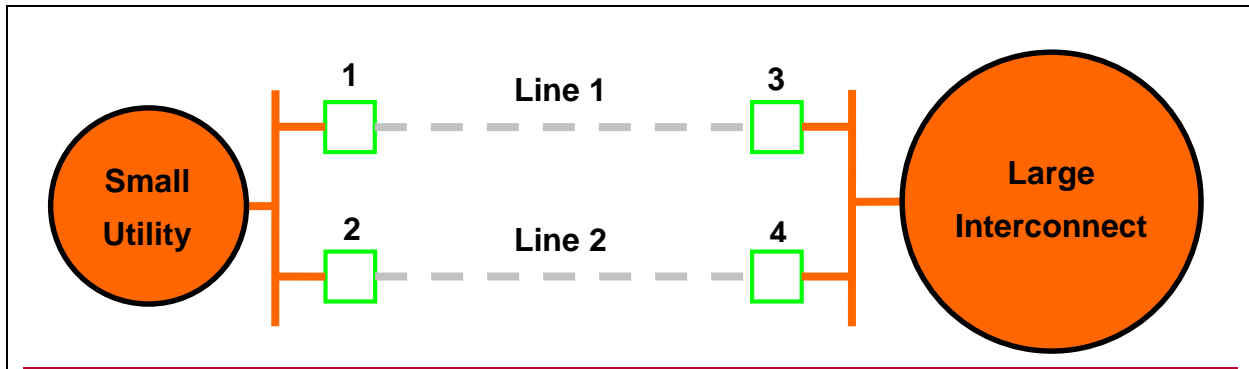
In Figure 23 the relays at circuit breakers 1, 2, 3, and 4 are equipped with a typical overreaching Zone 2 pilot system, using a Directional Comparison Blocking (DCB) scheme. Internal faults (or power swings) will result in instantaneous tripping of the Zone 2 relays if the measured fault or power swing impedance falls within the zone 2 operating characteristic. These lines will trip on pilot Zone 2 for out-of-step conditions if the power swing impedance characteristic enters into Zone 2. All breakers are rated for out-of-phase switching.



**Figure 24:** In this case, the Zone 2 element on circuit breakers 1, 2, 3, and 4 did not meet the PRC-026-1 – Attachment B criteria (this figure depicts the power swing as seen by relays on breakers 3 and 4).

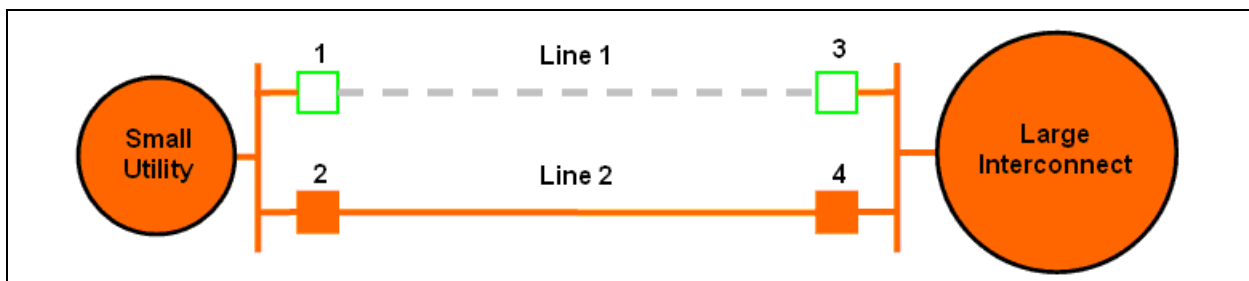
In Figure 24, a large disturbance occurs within the small utility and its system goes out-of-step with the large interconnect. The small utility is importing power at the time of the disturbance. The actual power swing, as shown by the solid green line, enters the Zone 2 relay characteristic on the terminals of Lines 1, 2, 3, and 4 causing both lines to trip as shown in Figure 25.





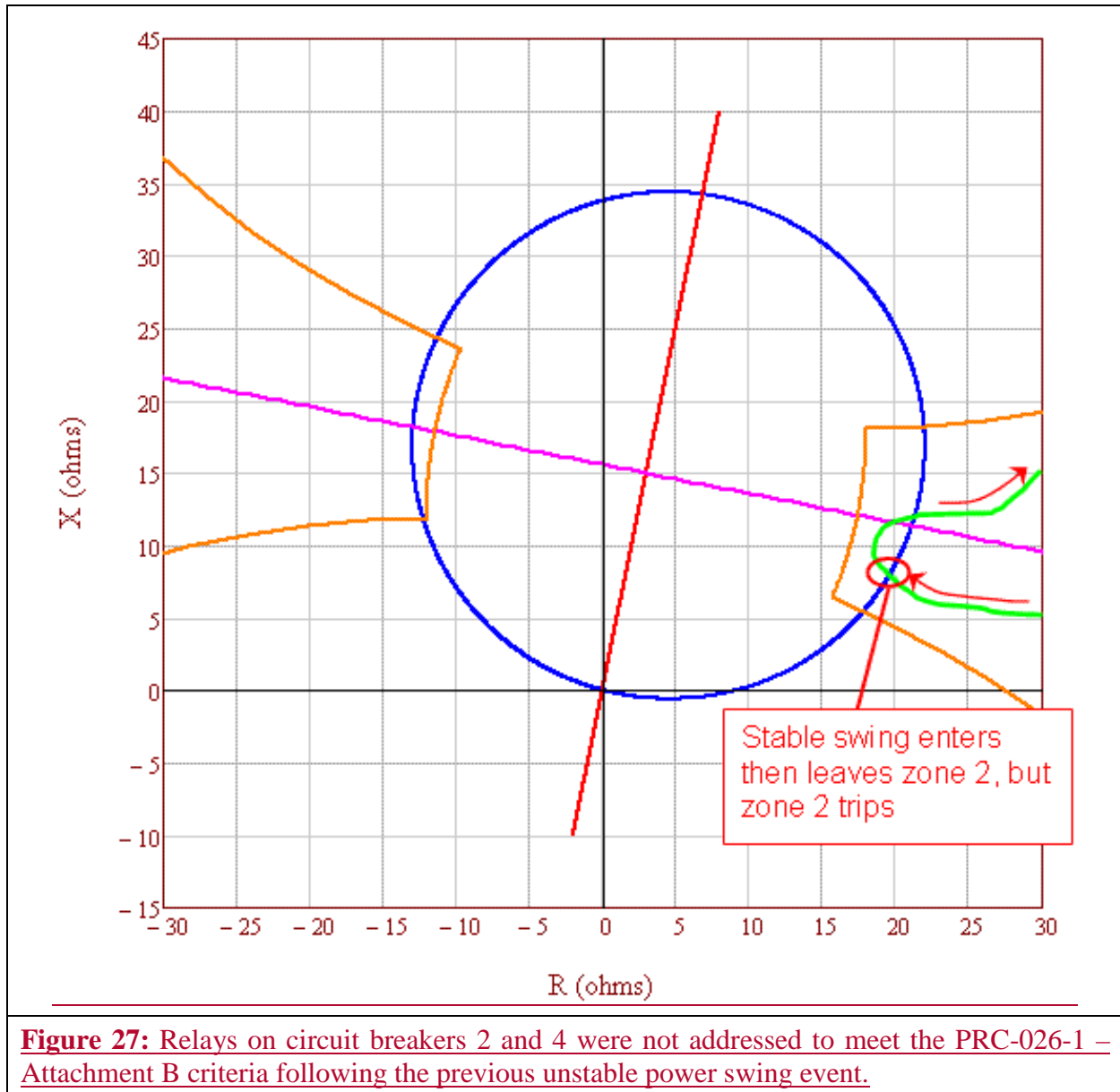
**Figure 25:** Islanding of the small utility due to Lines 1 and 2 tripping in response to an unstable power swing.

In Figure 25, the relays at circuit breakers 1, 2, 3, and 4 have correctly tripped due to the unstable power swing (shown by the dashed green line in Figure 24), de-energizing Lines 1 and 2, and creating an island between the small utility and the big interconnect. The small utility shed 500 MW of load on underfrequency and maintained a load to generation balance.

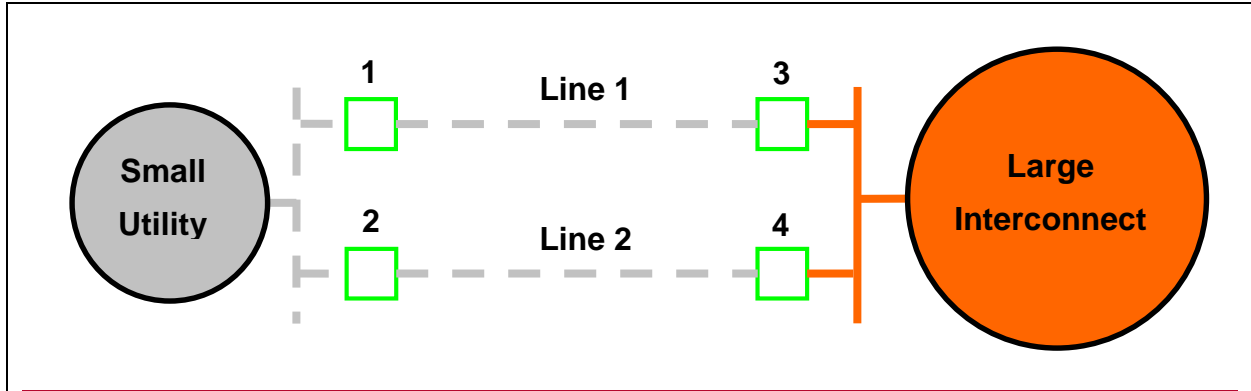


**Figure 26:** Line 1 is out-of-service for maintenance, Line 2 is loaded beyond its normal rating (but within its emergency rating).

Subsequent to the correct tripping of Lines 1 and 2 for the unstable power swing in Figure 25, another system disturbance occurs while the system is operating with Line 1 out-of-service for maintenance. The disturbance causes a stable power swing on Line 2, which challenges the relays at circuit breakers 2 and 4 as shown in Figure 27.



If the relays on circuit breakers 2 and 4 were not addressed under the Requirements for the previous unstable power swing condition, the relays would trip in response to the stable power swing, which would result in unnecessary system separation, load shedding, and possibly cascading or blackout.



**Figure 28:** Possible blackout of the small utility.

If the relays that tripped in response to the previous unstable power swing condition in Figure 24 were addressed under the Requirements to meet PRC-026-1 - Attachment B criteria, the unnecessary tripping of the relays for the stable power swing shown in Figure 28 would have been averted, and the possible blackout of the small utility would have been avoided.

## Implementation Plan

### Project 2010-13.3 – Relay Loadability: Stable Power Swings

#### Requested Approvals

PRC-026-1 – Relay Performance During Stable Power Swings

#### Requested Retirements

None.

#### Prerequisite Approvals

None.

#### General Considerations

There are a number of factors that influenced the determination of an implementation period for the new proposed standard. The following factors may be specific to one or more of the applicable entities listed below.

1. The effort and resources for all applicable entities to develop or modify internal processes and/or procedures.
2. The effort and resources for the Planning Coordinator to begin identifying Element(s) according to the criteria in Requirement R1 is based on existing information (e.g., the most recent Planning Assessment).
3. The notification of Elements in Requirement R1 is based on the Planning Coordinator's existing studies (i.e., annual Planning Assessments) and there will be minimal additional effort to identify Elements according to the criteria.
4. The need for the Generator Owner or Transmission Owner to plan for and secure resources (e.g., availability of consultants, if needed) to address the initial influx of Element notifications from the Planning Coordinator during the implementation period of Requirement R2.

#### Applicable Entities

Generator Owner

Planning Coordinator

Transmission Owner

## Effective Dates

### *Requirement R1*

First day of the first full calendar year that is 12 months after the date that the standard is approved by an applicable governmental authority or as otherwise provided for in a jurisdiction where approval by an applicable governmental authority is required for a standard to go into effect. Where approval by an applicable governmental authority is not required, the standard shall become effective on the first day of the first full calendar year that is 12 months after the date the standard is adopted by the NERC Board of Trustees or as otherwise provided for in that jurisdiction.

### *Requirements R2, R3, and R4*

First day of the first full calendar year that is 36 months after the date that the standard is approved by an applicable governmental authority or as otherwise provided for in a jurisdiction where approval by an applicable governmental authority is required for a standard to go into effect. Where approval by an applicable governmental authority is not required, the standard shall become effective on the first day of the first full calendar year that is 36 months after the date the standard is adopted by the NERC Board of Trustees or as otherwise provided for in that jurisdiction.

## Notifications Prior to the Effective Date of Requirement R2

The implementation plan is designed such that the Planning Coordinator will begin notifying the respective Generator Owners and Transmission Owners of any Elements in Requirement R1 based on the effective date language. The 36 months for the Generator Owner and Transmission Owner in Requirement R2 (and Requirements R3 and R4) to become compliant is intended to allow the entity an opportunity to address the initial influx of identified Elements in Requirement R1. There is no obligation on the Generator Owner or Transmission Owner to perform Requirement R2, R3, or R4 until the effective date of these Requirements. Although there is no compliance obligation during the 36 month implementation period, an entity will have the full obligation of Requirements R2, R3, and R4 following the 36 month period. The 36 month implementation period also allows an opportunity for the entity to establish the evaluation of load-responsive protective relays pursuant to Requirement R2 which will provide the point in time that the five year re-evaluation of such relays will occur. ~~“No change made.”~~

## Justification

The implementation plan is based on the general considerations above and provides sufficient time for the Generator Owner, Planning Coordinator, and Transmission Owner to begin becoming compliant with the standard. The Effective date is constructed such that once the standard is adopted or approved it would become effective on the first day of the first whole calendar year that is 12 months for Requirement R1 and 36 months for Requirements R2, R3, and R4 after applicable adoption or approval.

**Requirement R1** – The Planning Coordinator will have at least one full calendar year to prepare itself to identify any generator, transformer, and transmission line BES Elements that meet the criteria and notify the respective Generator Owner and Transmission Owner of identified Elements, if any, within the allotted timeframe.

**Requirement R2** – The Generator Owner and Transmission Owner will have 36 calendar months to determine if its load-responsive protective relays for an identified Element pursuant to Requirement R1 meet the PRC-026-1 – Attachment B criteria for the initial influx of Elements. Also, both entities are provided an implementation that will allow the entity to conduct initial evaluations of its load-responsive protective relays for an identified Element during the first 36 calendar months of approval.

**Requirement R3** – The implementation period for the development of a Corrective Action Plan (CAP) is set to be consistent with Requirement R2 to begin during the fourth calendar year of adoptions or approvals to address any load-responsive protective relays determined in Requirement R2 not to meet the PRC-026-1 – Attachment B criteria.

**Requirement R4** – The implementation period for this Requirement is set to be consistent with Requirement R3, the development of a CAP.

# Implementation Plan

## Project 2010-13.3 – Relay Loadability: Stable Power Swings

### Requested Approvals

PRC-026-1 – Relay Performance During Stable Power Swings

### Requested Retirements

None.

### Prerequisite Approvals

None.

### General Considerations

There are a number of factors that ~~influence~~influenced the determination of an implementation period for the new proposed standard. The following factors may be specific to one or more of the applicable entities listed below.

1. The effort and resources for all applicable entities to develop or modify internal processes and/or procedures.
2. The effort and resources for the Planning Coordinator to begin identifying Element(s) according to the criteria in Requirement R1 is based on existing information (e.g., the most recent Planning Assessment).
3. The notification of Elements in Requirement R1 is based on the Planning Coordinator's existing studies (i.e., annual Planning Assessments) and there will be minimal additional effort to identify Elements according to the criteria.
4. The need for the Generator Owner or Transmission Owner to plan for and secure resources (e.g., availability of consultants, if needed) to address the initial influx of ~~Elements~~Element notifications from the Planning Coordinator during the implementation period of Requirement R2.

### Applicable Entities

Generator Owner  
Planning Coordinator  
Transmission Owner

## Effective Dates

### *Requirement R1*

First day of the first full calendar year that is 12 months after the date that the standard is approved by an applicable governmental authority or as otherwise provided for in a jurisdiction where approval by an applicable governmental authority is required for a standard to go into effect. Where approval by an applicable governmental authority is not required, the standard shall become effective on the first day of the first full calendar year that is 12 months after the date the standard is adopted by the NERC Board of Trustees or as otherwise provided for in that jurisdiction.

### *Requirements R2, R3, and R4*

First day of the first full calendar year that is 36 months after the date that the standard is approved by an applicable governmental authority or as otherwise provided for in a jurisdiction where approval by an applicable governmental authority is required for a standard to go into effect. Where approval by an applicable governmental authority is not required, the standard shall become effective on the first day of the first full calendar year that is 36 months after the date the standard is adopted by the NERC Board of Trustees or as otherwise provided for in that jurisdiction.

## Notifications Prior to the Effective Date of **Requirement R2**

~~During the implementation of the standard, notifications are likely to occur prior to Requirement R2 becoming effective. Where notification of Elements under Requirement R1 or becoming aware of an Element tripping due to a stable or unstable power swing prior to the Effective Date of Requirement R2, the 12 month time period to evaluate if an Element's load-responsive protective relays meet the criteria in PRC-026-1 – Attachment B in Requirement R2 will begin, as expected, from the Effective Date of Requirement R2. Thereafter, entities will follow the 12 month time period in accordance with Requirement R2. The intention of the additional time for R2 to become effective is to handle the initial influx of notifications and identifications.~~

The implementation plan is designed such that the Planning Coordinator will begin notifying the respective Generator Owners and Transmission Owners of any Elements in Requirement R1 based on the effective date language. The 36 months for the Generator Owner and Transmission Owner in Requirement R2 (and Requirements R3 and R4) to become compliant is intended to allow the entity an opportunity to address the initial influx of identified Elements in Requirement R1. There is no obligation on the Generator Owner or Transmission Owner to perform Requirement R2, R3, or R4 until the effective date of these Requirements. Although there is no compliance obligation during the 36 month implementation period, an entity will have the full obligation of Requirements R2, R3, and R4 following the 36 month period. The 36 month implementation period also allows an opportunity for the entity to establish the evaluation of load-responsive protective relays pursuant to Requirement R2 which will provide the point in time that the five year re-evaluation of such relays will occur.



## Justification

The implementation plan is based on the general considerations above and provides sufficient time for the Generator Owner, Planning Coordinator, and Transmission Owner to begin becoming compliant with the standard. The Effective date is constructed such that once the standard is adopted or approved it would become effective on the first day of the first whole calendar year that is 12 months for Requirement R1 and 36 months for Requirements R2, R3, and R4 after applicable adoption or approval.

**Requirement R1** – The Planning Coordinator will have at least one full calendar year to prepare itself to identify any generator, transformer, and transmission line BES Elements that meet the criteria and notify the respective Generator Owner and Transmission Owner of identified Elements, if any, within the allotted timeframe.

**Requirement R2** – The Generator Owner and Transmission Owner will have 36 calendar months to determine if its load-responsive protective relays for an identified Element pursuant to Requirement R1 meet the PRC-026-1 – Attachment B criteria for the initial influx of Elements. Also, both entities are provided an implementation that will allow the entity to conduct initial evaluations of its load-responsive protective relays for an identified Element during the first 36 calendar months of approval.

**Requirement R3** – The implementation period for the development of a Corrective Action Plan (CAP) is set to be consistent with Requirement R2 to begin during the fourth calendar year of adoptions or approvals to address any load-responsive protective relays determined in Requirement R2 not to meet the PRC-026-1 – Attachment B criteria.

**Requirement R4** – The implementation period for this Requirement is set to be consistent with Requirement R3, the development of a CAP.

# Violation Risk Factors and Violation Severity Level Justifications

Project 2010-13.3 – Relay Loadability: Stable Power Swings  
(PRC-026-1 – Relay Performance During Stable Power Swings)

## Violation Risk Factor and Violation Severity Level Justifications

This document provides the drafting team's justification for assignment of violation risk factors (VRFs) and violation severity levels (VSLs) for each requirement in: PRC-026-1 – Relay Performance During Stable Power Swings.

Each primary requirement is assigned a VRF and a set of one or more VSLs. These elements support the determination of an initial value range for the Base Penalty Amount regarding violations of requirements in FERC-approved Reliability Standards, as defined in the ERO Sanction Guidelines.

The Protection System Response to Power Swings Standard Drafting Team applied the following NERC criteria and FERC Guidelines when proposing VRFs and VSLs for the requirements under this project.

### **NERC Criteria - Violation Risk Factors**

#### ***High Risk Requirement***

A requirement that, if violated, could directly cause or contribute to bulk electric system instability, separation, or a cascading sequence of failures, or could place the bulk electric system at an unacceptable risk of instability, separation, or cascading failures; or, a requirement in a planning time frame that, if violated, could, under emergency, abnormal, or restorative conditions anticipated by the preparations, directly cause or contribute to bulk electric system instability, separation, or a cascading sequence of failures, or could place the bulk electric system at an unacceptable risk of instability, separation, or cascading failures, or could hinder restoration to a normal condition.

#### ***Medium Risk Requirement***

A requirement that, if violated, could directly affect the electrical state or the capability of the bulk electric system, or the ability to effectively monitor and control the bulk electric system. However, violation of a medium risk requirement is unlikely to lead to bulk electric system instability, separation, or cascading failures; or, a requirement in a planning time frame that, if violated, could, under emergency, abnormal, or restorative conditions anticipated by the preparations, directly and adversely affect the electrical state or capability of the bulk electric system, or the ability to effectively monitor, control, or restore the bulk electric system.

However, violation of a medium risk requirement is unlikely, under emergency, abnormal, or restoration conditions anticipated by the preparations, to lead to bulk electric system instability, separation, or cascading failures, nor to hinder restoration to a normal condition.

### ***Lower Risk Requirement***

A requirement that is administrative in nature and a requirement that, if violated, would not be expected to adversely affect the electrical state or capability of the bulk electric system, or the ability to effectively monitor and control the bulk electric system; or, a requirement that is administrative in nature and a requirement in a planning time frame that, if violated, would not, under the emergency, abnormal, or restorative conditions anticipated by the preparations, be expected to adversely affect the electrical state or capability of the bulk electric system, or the ability to effectively monitor, control, or restore the bulk electric system. A planning requirement that is administrative in nature.

### **FERC Violation Risk Factor Guidelines**

The standard drafting team (SDT) also considered consistency with the FERC Violation Risk Factor Guidelines for setting VRFs:<sup>1</sup>

#### **Guideline (1) — Consistency with the Conclusions of the Final Blackout Report**

The Commission seeks to ensure that Violation Risk Factors assigned to Requirements of Reliability Standards in these identified areas appropriately reflect their historical critical impact on the reliability of the Bulk-Power System.

In the VSL Order, FERC listed critical areas (from the Final Blackout Report) where violations could severely affect the reliability of the Bulk-Power System:<sup>2</sup>

- Emergency operations
- Vegetation management
- Operator personnel training
- Protection systems and their coordination
- Operating tools and backup facilities
- Reactive power and voltage control
- System modeling and data exchange
- Communication protocol and facilities
- Requirements to determine equipment ratings
- Synchronized data recorders
- Clearer criteria for operationally critical facilities
- Appropriate use of transmission loading relief

#### **Guideline (2) — Consistency within a Reliability Standard**

<sup>1</sup> North American Electric Reliability Corp., 119 FERC ¶ 61,145, order on reh'g and compliance filing, 120 FERC ¶ 61,145 (2007) ("VRF Rehearing Order").

<sup>2</sup> Id. at footnote 15.

The Commission expects a rational connection between the sub-Requirement Violation Risk Factor assignments and the main Requirement Violation Risk Factor assignment.

**Guideline (3) – Consistency among Reliability Standards**

The Commission expects the assignment of Violation Risk Factors corresponding to Requirements that address similar reliability goals in different Reliability Standards would be treated comparably.

**Guideline (4) – Consistency with NERC’s Definition of the Violation Risk Factor Level**

Guideline (4) was developed to evaluate whether the assignment of a particular Violation Risk Factor level conforms to NERC’s definition of that risk level.

**Guideline (5) – Treatment of Requirements that Co-mingle More Than One Obligation**

Where a single Requirement co-mingles a higher risk reliability objective and a lesser risk reliability objective, the VRF assignment for such Requirements must not be watered down to reflect the lower risk level associated with the less important objective of the Reliability Standard.

**NERC Criteria - Violation Severity Levels**

Violation Severity Levels (VSLs) define the degree to which compliance with a requirement was not achieved. Each requirement must have at least one VSL. While it is preferable to have four VSLs for each requirement, some requirements do not have multiple “degrees” of noncompliant performance and may have only one, two, or three VSLs.

Violation severity levels should be based on the guidelines shown in the table below:

Lower	Moderate	High	Severe
Missing a minor element (or a small percentage) of the required performance The performance or product measured has significant value as it almost meets the full intent of the requirement.	Missing at least one significant element (or a moderate percentage) of the required performance. The performance or product measured still has significant value in meeting the intent of the requirement.	Missing more than one significant element (or is missing a high percentage) of the required performance or is missing a single vital component. The performance or product has limited value in meeting the intent of the requirement.	Missing most or all of the significant elements (or a significant percentage) of the required performance. The performance measured does not meet the intent of the requirement or the product delivered cannot be used in meeting the intent of the requirement.

***FERC Order on Violation Severity Levels***

In its June 19, 2008 Order on Violation Severity Levels, FERC indicated it would use the following four guidelines for determining whether to approve VSLs:

***Guideline 1: Violation Severity Level Assignments Should Not Have the Unintended Consequence of Lowering the Current Level of Compliance***

Compare the VSLs to any prior Levels of Non-compliance and avoid significant changes that may encourage a lower level of compliance than was required when Levels of Non-compliance were used.

***Guideline 2: Violation Severity Level Assignments Should Ensure Uniformity and Consistency in the Determination of Penalties***

Guideline 2a: A violation of a “binary” type requirement must be a “Severe” VSL.

Guideline 2b: Do not use ambiguous terms such as “minor” and “significant” to describe noncompliant performance.

***Guideline 3: Violation Severity Level Assignment Should Be Consistent with the Corresponding Requirement***

VSLs should not expand on what is required in the requirement.

***Guideline 4: Violation Severity Level Assignment Should Be Based on A Single Violation, Not on A Cumulative Number of Violations***

. . . unless otherwise stated in the requirement, each instance of non-compliance with a requirement is a separate violation. Section 4 of the Sanction Guidelines states that assessing penalties on a per violation per day basis is the “default” for penalty calculations.

VRF and VSL Justifications – PRC-026-1, R1	
Proposed VRF	Medium
NERC VRF Discussion	<p>A Violation Risk Factor of Medium is consistent with the NERC VRF Guidelines:</p> <p>A failure to notify the respective Generator Owner or Transmission Owner of the BES Element(s) that meet the Requirement R1 criteria prohibits further evaluation of any load-responsive protective relay applied at the terminal of the Element(s). A load-responsive protective relay that goes without evaluation may not be secure for a stable power swing and could, in the planning time frame, under emergency, abnormal, or restorative conditions anticipated by the preparations, directly and adversely affect the electrical state or capability of the bulk electric system, or the ability to effectively monitor, control, or restore the bulk electric system.</p>
FERC VRF G1 Discussion	<p>Guideline 1- Consistency w/ Blackout Report:</p> <p>The blackout report and subsequent technical analysis identified that two Bulk Power System (BPS) transmission lines tripped due to protective relay operation in response to stable power swings. The Protection System operations on these lines did not contribute significantly to the overall outcome of the August 14, 2003 system disturbance; however, Protection System operation during stable powers swings could negatively impact system reliability under different operating conditions. Identification and evaluation of BES Elements susceptible to power swings and the subsequent mitigation of load-responsive protective relays applied at the terminals of these BES Elements that do not meet the PRC-026-1 – Attachment B criteria will reduce the likelihood of reoccurrence.</p> <p>This Requirement is consistent with the intent of Recommendation 8: Improve System Protection to Slow or Limit the Spread of Future Cascading Outages. While the actions associated with this recommendation did not focus specifically on the issue of Protection Systems tripping in response to stable power swings, the recommendation does note that “power system protection devices should be set to address the specific condition of concern, such as a fault, out-of-step condition, etc., and should not compromise a power system’s inherent physical capability to slow down or stop a cascading event.”</p>

VRF and VSL Justifications – PRC-026-1, R1	
FERC VRF G2 Discussion	<p>Guideline 2- Consistency within a Reliability Standard:</p> <p>The Requirement has a single reliability activity associated with the reliability objective and no sub-Requirement(s) which allows a single VRF to be assigned; therefore no conflict(s) exist.</p>
FERC VRF G3 Discussion	<p>Guideline 3- Consistency among Reliability Standards:</p> <p>The Requirement is consistent with NERC Reliability Standard FAC-014-2, R6 (“...Planning Authority shall identify the subset of multiple contingencies...”) which has a VRF of Medium.</p>
FERC VRF G4 Discussion	<p>Guideline 4- Consistency with NERC Definitions of VRFs:</p> <p>A failure of the Planning Coordinator to notify the respective Generator Owner or Transmission Owner of the BES Element(s) that meet the Requirement R1 criteria prohibits further evaluation of any load-responsive protective relay applied at the terminal of the Element. A load-responsive protective relay that goes without evaluation may not be secure for a stable power swing and could, in the planning time frame, under emergency, abnormal, or restorative conditions anticipated by the preparations, directly and adversely affect the electrical state or capability of the bulk electric system, or the ability to effectively monitor, control, or restore the bulk electric system.</p>
FERC VRF G5 Discussion	<p>Guideline 5- Treatment of Requirements that Co-mingle More than One Obligation:</p> <p>This Requirement does not co-mingle reliability objectives of differing risk; therefore, the assigned VRF of Medium is consistent.</p>

VRF and VSL Justifications – PRC-026-1, R1			
Proposed VSL			
Lower	Moderate	High	Severe
The Planning Coordinator provided notification of the BES Element(s) in accordance with Requirement R1, but was less than or equal to 30 calendar days late.	The Planning Coordinator provided notification of the BES Element(s) in accordance with Requirement R1, but was more than 30 calendar days and less than or equal to 60 calendar days late.	The Planning Coordinator provided notification of the BES Element(s) in accordance with Requirement R1, but was more than 60 calendar days and less than or equal to 90 calendar days late.	The Planning Coordinator provided notification of the BES Element(s) in accordance with Requirement R1, but was more than 90 calendar days late.  OR The Planning Coordinator failed to provide notification of the BES Element(s) in accordance with Requirement R1.
NERC VSL Guidelines	Meets NERC’s VSL Guidelines—There is an incremental aspect to the VSL for tardiness and a binary aspect for failure. The VSL is entity size-neutral because performance is Element-driven and not by the total assets which an entity may have awareness over.		
FERC VSL G1 Violation Severity Level Assignments Should Not Have the Unintended Consequence of Lowering the Current Level of Compliance	The proposed VSL does not lower the current level of compliance because the Requirement is new.		



VRF and VSL Justifications – PRC-026-1, R1

<p>FERC VSL G2</p> <p>Violation Severity Level Assignments Should Ensure Uniformity and Consistency in the Determination of Penalties</p> <p>Guideline 2a: The Single Violation Severity Level Assignment Category for "Binary" Requirements Is Not Consistent</p> <p>Guideline 2b: Violation Severity Level Assignments that Contain Ambiguous Language</p>	<p>Guideline 2a:</p> <p>This Requirement is binary and utilizes a VSL of Severe for failure in addition to incremental VSLs for tardiness.</p> <p>Guideline 2b:</p> <p>The proposed VSL does not use any ambiguous terminology, thereby supporting uniformity and consistency in the determination of similar penalties for similar violations.</p>
<p>FERC VSL G3</p> <p>Violation Severity Level Assignment Should Be Consistent with the Corresponding Requirement</p>	<p>The proposed VSL uses similar terminology to that used in the corresponding Requirement, and is therefore consistent with the Requirement.</p>
<p>FERC VSL G4</p> <p>Violation Severity Level Assignment Should Be Based on A Single Violation, Not on A Cumulative Number of Violations</p>	<p>The VSL is based on a single violation and not cumulative violations.</p>

VRF and VSL Justifications – PRC-026-1, R2

Proposed VRF	High
NERC VRF Discussion	<p>A Violation Risk Factor of High is consistent with the NERC VRF Guidelines:</p> <p>A failure to evaluate the Protection System to determine that it is expected to not trip for a stable power swing for a BES Element could, under emergency, abnormal, or restorative conditions anticipated by the preparations, directly cause or contribute to bulk electric system instability, separation, or a cascading sequence of failures, or could place the bulk electric system at an unacceptable risk of instability, separation, or cascading failures, or could hinder restoration to a normal condition.</p> <p>A Protection System that does not meet the PRC-026-1 – Attachment B criteria is less secure during stable power swings, which increases the risk of tripping should the Protection System be challenged by a power swing.</p>
FERC VRF G1 Discussion	<p>Guideline 1- Consistency w/ Blackout Report:</p> <p>The blackout report and subsequent technical analysis identified that two bulk power system (BPS) transmission lines tripped due to protective relay operation in response to stable power swings. The Protection System operations on these lines did not contribute significantly to the overall outcome of the August 14, 2003 system disturbance; however, Protection System operation during stable powers swings could negatively impact system reliability under different operating conditions. Evaluation of load-responsive protective relays applied at the terminals of identified BES Elements will allow the Generator Owner and Transmission Owner to determine whether the load-responsive protective relays meet the PRC-026-1 – Attachment B criteria.</p> <p>This Requirement is consistent with the intent of Recommendation 8: Improve System Protection to Slow or Limit the Spread of Future Cascading Outages. While the actions associated with this recommendation did not focus specifically on this issue of Protection Systems tripping in response to stable power swings, the recommendation does note that “power system protection devices should be set to address the specific condition of concern, such as a fault, out-of-step condition, etc., and should not compromise a power system’s inherent physical capability to slow down or stop a cascading event.”</p>

VRF and VSL Justifications – PRC-026-1, R2	
FERC VRF G2 Discussion	<p>Guideline 2- Consistency within a Reliability Standard:</p> <p>The Requirement has a single reliability activity associated with the reliability objective and no sub-Requirement(s) which allows a single VRF to be assigned; therefore no conflict(s) exist.</p>
FERC VRF G3 Discussion	<p>Guideline 3- Consistency among Reliability Standards:</p> <p>The Requirement is consistent with NERC Reliability Standard PRC-023-3, R1 (“...Each Transmission Owner, Generator Owner, and Distribution Provider shall evaluate relay loadability at 0.85 per unit voltage and a power factor angle of 30 degrees”) which has a VRF of High.</p>
FERC VRF G4 Discussion	<p>Guideline 4- Consistency with NERC Definitions of VRFs:</p> <p>A failure of the Generator Owner or Transmission Owner to evaluate that the Protection System is expected to not trip in response to a stable power swing during a non-Fault condition for a BES Element could, under emergency, abnormal, or restorative conditions anticipated by the preparations, directly cause or contribute to bulk electric system instability, separation, or a cascading sequence of failures, or could place the bulk electric system at an unacceptable risk of instability, separation, or cascading failures, or could hinder restoration to a normal condition.</p> <p>A Protection System that does not meet the PRC-026-1 – Attachment B criteria is less secure during stable power swings, it increases the risk of tripping should the Protection System be challenged by a power swing.</p>
FERC VRF G5 Discussion	<p>Guideline 5- Treatment of Requirements that Co-mingle More than One Obligation:</p> <p>This Requirement does not co-mingle reliability objectives of differing risk; therefore, the assigned VRF of Medium is consistent.</p>

VRF and VSL Justifications – PRC-026-1, R2			
Proposed VSL			
Lower	Moderate	High	Severe
The Generator Owner or Transmission Owner evaluated its load-responsive protective relay(s) in accordance with Requirement R2, but was less than or equal to 30 calendar days late.	The Generator Owner or Transmission Owner evaluated its load-responsive protective relay(s) in accordance with Requirement R2, but was more than 30 calendar days and less than or equal to 60 calendar days late.	The Generator Owner or Transmission Owner evaluated its load-responsive protective relay(s) in accordance with Requirement R2, but was more than 60 calendar days and less than or equal to 90 calendar days late.	The Generator Owner or Transmission Owner evaluated its load-responsive protective relay(s) in accordance with Requirement R2, but was more than 90 calendar days late.  OR The Generator Owner or Transmission Owner failed to evaluate its load-responsive protective relay(s) in accordance with Requirement R2.
NERC VSL Guidelines	Meets NERC’s VSL Guidelines—There is an incremental aspect to the VSL for tardiness and a binary aspect for failure. The VSL is entity size-neutral because performance is driven by exception. For example, each identified Element must be evaluated.		
FERC VSL G1 Violation Severity Level Assignments Should Not Have the Unintended Consequence of Lowering the Current Level of Compliance	The proposed VSL does not lower the current level of compliance because the Requirement is new.		

VRF and VSL Justifications – PRC-026-1, R2

<p>FERC VSL G2</p> <p>Violation Severity Level Assignments Should Ensure Uniformity and Consistency in the Determination of Penalties</p> <p>Guideline 2a: The Single Violation Severity Level Assignment Category for "Binary" Requirements Is Not Consistent</p> <p>Guideline 2b: Violation Severity Level Assignments that Contain Ambiguous Language</p>	<p>Guideline 2a:</p> <p>This Requirement is not binary; therefore, this criterion does not apply.</p> <p>Guideline 2b:</p> <p>The proposed VSL does not use any ambiguous terminology, thereby supporting uniformity and consistency in the determination of similar penalties for similar violations.</p>
<p>FERC VSL G3</p> <p>Violation Severity Level Assignment Should Be Consistent with the Corresponding Requirement</p>	<p>The proposed VSL uses similar terminology to that used in the corresponding Requirement, and is therefore consistent with the Requirement.</p>
<p>FERC VSL G4</p> <p>Violation Severity Level Assignment Should Be Based on A Single Violation, Not on A Cumulative Number of Violations</p>	<p>The VSL is based on a single violation and not cumulative violations.</p>

VRF and VSL Justifications – PRC-004-3, R3

Proposed VRF	Medium
NERC VRF Discussion	<p>A Violation Risk Factor of Medium is consistent with the NERC VRF Guidelines:</p> <p>Failure to develop a Corrective Action Plan (CAP) such that the Protection System of a BES Element will meet the PRC-026-1 – Attachment B criteria or to exclude the Protection System under the PRC-026-1 – Attachment A criteria (e.g., modifying the Protection System so that relay functions are supervised by power swing blocking or using relay systems that are immune to power swings) could in the planning time frame, under emergency, abnormal, or restorative conditions anticipated by the preparations, directly and adversely affect the electrical state or capability of the bulk electric system, or the ability to effectively monitor, control, or restore the bulk electric system.</p>
FERC VRF G1 Discussion	<p>Guideline 1- Consistency w/ Blackout Report:</p> <p>The blackout report and subsequent technical analysis identified that two bulk power system (BPS) transmission lines tripped due to protective relay operation in response to stable power swings. The Protection System operations on these lines did not contribute significantly to the overall outcome of the August 14, 2003 system disturbance; however, Protection System operation during stable powers swings could negatively impact system reliability under different operating conditions. Developing a CAP such that the Protection System will meet the Attachment B criteria or to exclude the Protection System under the PRC-026-1 – Attachment A criteria (e.g., modifying the Protection System so that relay functions are supervised by power swing blocking or using relay systems that are immune to power swings) applied at the terminals of BES Elements will reduce the likelihood of reoccurrence.</p> <p>This Requirement is consistent with the intent of Recommendation 8: Improve System Protection to Slow or Limit the Spread of Future Cascading Outages. While the actions associated with this recommendation did not focus specifically on this issue of Protection Systems tripping in response to stable power swings, the recommendation does note that “power system protection devices should be set to address the specific condition of concern, such as a fault, out-of-step condition, etc., and should not compromise a power system’s inherent physical capability to slow down or stop a cascading event.”</p>

VRF and VSL Justifications – PRC-004-3, R3	
FERC VRF G2 Discussion	<p>Guideline 2- Consistency within a Reliability Standard:</p> <p>This Requirement has a single reliability activity associated with the reliability objective and no sub-Requirement(s) which allows a single VRF to be assigned; therefore no conflict(s) exist.</p>
FERC VRF G3 Discussion	<p>Guideline 3- Consistency among Reliability Standards:</p> <p>This Requirement is consistent with the following Reliability Standards which require corrective actions (e.g., Corrective Action Plans); PRC-016-0.1, R2 (“...shall take corrective actions to avoid future Misoperations”), PRC-022-1, R1.5 (“For any Misoperation, a Corrective Action Plan...”), and FAC-003, R5 (“...Transmission Owner or applicable Generator Owner shall take corrective action to ensure continued vegetation management”) all three of which have a VRF of Medium.</p>
FERC VRF G4 Discussion	<p>Guideline 4- Consistency with NERC Definitions of VRFs:</p> <p>A Violation Risk Factor of Medium is consistent with the NERC VRF Guidelines:</p> <p>A failure to develop the Corrective Action Plan (CAP) such that the Protection System of a BES Element will meet the Attachment B criteria or to exclude the Protection System under the PRC-026-1 – Attachment A criteria (e.g., modifying the Protection System so that relay functions are supervised by power swing blocking or using relay systems that are immune to power swings) could, in the planning time frame, under emergency, abnormal, or restorative conditions anticipated by the preparations, directly and adversely affect the electrical state or capability of the bulk electric system, or the ability to effectively monitor, control, or restore the bulk electric system.</p>
FERC VRF G5 Discussion	<p>Guideline 5- Treatment of Requirements that Co-mingle More than One Obligation:</p> <p>This requirement does not co-mingle reliability objectives of differing risk; therefore, the assigned VRF of Medium is consistent.</p>

VRF and VSL Justifications – PRC-004-3, R3			
Proposed VSL			
Lower	Moderate	High	Severe
The Generator Owner or Transmission Owner developed a Corrective Action Plan (CAP) in accordance with Requirement R3, but in more than six calendar months and less than or equal to seven calendar months.	The Generator Owner or Transmission Owner developed a Corrective Action Plan (CAP) in accordance with Requirement R3, but in more than seven calendar months and less than or equal to eight calendar months.	The Generator Owner or Transmission Owner developed a Corrective Action Plan (CAP) in accordance with Requirement R3, but in more than eight calendar months and less than or equal to nine calendar months.	The Generator Owner or Transmission Owner developed a Corrective Action Plan (CAP) in accordance with Requirement R3, but in more than nine calendar months.  OR The Generator Owner or Transmission Owner failed to develop a CAP in accordance with Requirement R3.
NERC VSL Guidelines	Meets NERC’s VSL Guidelines—There is an incremental aspect to the VSL for failing to develop the Corrective Action Plan in a timely fashion and a binary aspect for a complete failure. The VSL is entity size-neutral because performance is driven by the need to mitigate the Protection System so that it is expected to not trip on a stable power swing.		
FERC VSL G1 Violation Severity Level Assignments Should Not Have the Unintended Consequence of Lowering the Current Level of Compliance	The proposed VSL does not lower the current level of compliance because the Requirement is new.		



VRF and VSL Justifications – PRC-004-3, R3

<p>FERC VSL G2</p> <p>Violation Severity Level Assignments Should Ensure Uniformity and Consistency in the Determination of Penalties</p> <p>Guideline 2a: The Single Violation Severity Level Assignment Category for "Binary" Requirements Is Not Consistent</p> <p>Guideline 2b: Violation Severity Level Assignments that Contain Ambiguous Language</p>	<p>Guideline 2a:</p> <p>This Requirement is binary and utilizes a VSL of Severe for failure in addition to incremental VSLs for tardiness.</p> <p>Guideline 2b:</p> <p>This proposed VSL does not use any ambiguous terminology, thereby supporting uniformity and consistency in the determination of similar penalties for similar violations.</p>
<p>FERC VSL G3</p> <p>Violation Severity Level Assignment Should Be Consistent with the Corresponding Requirement</p>	<p>This proposed VSL uses similar terminology to that used in the corresponding Requirement, and is therefore consistent with this Requirement.</p>
<p>FERC VSL G4</p> <p>Violation Severity Level Assignment Should Be Based on A Single Violation, Not on A Cumulative Number of Violations</p>	<p>The VSL is based on a single violation and not cumulative violations.</p>

VRF and VSL Justifications – PRC-026-1, R4	
Proposed VRF	Medium
NERC VRF Discussion	<p>A Violation Risk Factor of Medium is consistent with the NERC VRF Guidelines:</p> <p>A failure to implement the Corrective Action Plan (CAP) to meet the PRC-026-1 – Attachment B criteria or to exclude the Protection System under the PRC-026-1 – Attachment A criteria (e.g., modifying the Protection System so that relay functions are supervised by power swing blocking or using relay systems that are immune to power swings) could, in the planning time frame, under emergency, abnormal, or restorative conditions anticipated by the preparations, directly and adversely affect the electrical state or capability of the bulk electric system, or the ability to effectively monitor, control, or restore the bulk electric system.</p>
FERC VRF G1 Discussion	<p>Guideline 1- Consistency w/ Blackout Report:</p> <p>The blackout report and subsequent technical analysis identified that two bulk power system (BPS) transmission lines tripped due to protective relay operation in response to stable power swings. The Protection System operations on these lines did not contribute significantly to the overall outcome of the August 14, 2003 system disturbance; however, Protection System operation during stable powers swings could negatively impact system reliability under different operating conditions. Implementing a CAP such that the Protection System will meet the Attachment B criteria or to exclude the Protection System under the PRC-026-1 – Attachment A criteria (e.g., modifying the Protection System so that relay functions are supervised by power swing blocking or using relay systems that are immune to power swings) applied at the terminals of these Elements will reduce the likelihood of reoccurrence.</p> <p>This Requirement is consistent with the intent of Recommendation 8: Improve System Protection to Slow or Limit the Spread of Future Cascading Outages. While the actions associated with this recommendation did not focus specifically on this issue of Protection Systems tripping in response to stable power swings, the recommendation does note that “power system protection devices should be set to address the</p>

VRF and VSL Justifications – PRC-026-1, R4	
	specific condition of concern, such as a fault, out-of-step condition, etc., and should not compromise a power system’s inherent physical capability to slow down or stop a cascading event.”
FERC VRF G2 Discussion	<p>Guideline 2- Consistency within a Reliability Standard:</p> <p>The Requirement has a single reliability activity associated with the reliability objective and no sub-Requirement(s) which allows a single VRF to be assigned; therefore no conflict(s) exist.</p>
FERC VRF G3 Discussion	<p>Guideline 3- Consistency among Reliability Standards:</p> <p>This Requirement is consistent with the following Reliability Standards which require corrective actions (e.g., Corrective Action Plans): PRC-016-0.1, R2 (“...shall take corrective actions to avoid future Misoperations”), PRC-022-1, R1.5 (“For any Misoperation, a Corrective Action Plan...”), and FAC-003, R5 (“...Transmission Owner or applicable Generator Owner shall take corrective action to ensure continued vegetation management”) all of which have a VRF of Medium.</p>
FERC VRF G4 Discussion	<p>A Violation Risk Factor of Medium is consistent with the NERC VRF Guidelines:</p> <p>A failure to implement the Corrective Action Plan such that the Protection System of a BES Element will meet the Attachment B criteria or to exclude the Protection System under the PRC-026-1 – Attachment A criteria (e.g., modifying the Protection System so that relay functions are supervised by power swing blocking or using relay systems that are immune to power swings) could, in the planning time frame, under emergency, abnormal, or restorative conditions anticipated by the preparations, directly and adversely affect the electrical state or capability of the bulk electric system, or the ability to effectively monitor, control, or restore the bulk electric system.</p>
FERC VRF G5 Discussion	<p>Guideline 5- Treatment of Requirements that Co-mingle More than One Obligation:</p> <p>This Requirement does not co-mingle reliability objectives of differing risk; therefore, the assigned VRF of Medium is consistent.</p>

VRF and VSL Justifications – PRC-026-1, R4			
Proposed VSL			
Lower	Moderate	High	Severe
The responsible entity implemented, but failed to update a CAP, when actions or timetables changed, in accordance with Requirement R4.	N/A	N/A	The responsible entity failed to implement a CAP in accordance with Requirement R4.
NERC VSL Guidelines			
Meets NERC’s VSL Guidelines—There is an incremental aspect to the VSL for failing to update the Corrective Action Plan and a binary aspect for failure to implement. The VSL is entity size-neutral because performance is driven by the need to mitigate the Protection System so that it is expected to not trip on a stable power swing.			
FERC VSL G1 Violation Severity Level Assignments Should Not Have the Unintended Consequence of Lowering the Current Level of Compliance			
The proposed VSL does not lower the current level of compliance because the Requirement is new.			
FERC VSL G2 Violation Severity Level Assignments Should Ensure Uniformity and Consistency in the Determination of Penalties			
Guideline 2a: This Requirement is not binary; therefore, this criterion does not apply.			

VRF and VSL Justifications – PRC-026-1, R4

<p>Guideline 2a: The Single Violation Severity Level Assignment Category for "Binary" Requirements Is Not Consistent</p> <p>Guideline 2b: Violation Severity Level Assignments that Contain Ambiguous Language</p>	<p>Guideline 2b:</p> <p>The proposed VSL does not use any ambiguous terminology, thereby supporting uniformity and consistency in the determination of similar penalties for similar violations.</p>
<p>FERC VSL G3</p> <p>Violation Severity Level Assignment Should Be Consistent with the Corresponding Requirement</p>	<p>The proposed VSL uses similar terminology to that used in the corresponding Requirement, and is therefore consistent with the Requirement.</p>
<p>FERC VSL G4</p> <p>Violation Severity Level Assignment Should Be Based on A Single Violation, Not on A Cumulative Number of Violations</p>	<p>The VSL is based on a single violation and not cumulative violations.</p>

# Violation Risk Factors and Violation Severity Level Justifications

Project 2010-13.3 – Relay Loadability: Stable Power Swings  
(PRC-026-1 – Relay Performance During Stable Power Swings)

## Violation Risk Factor and Violation Severity Level Justifications

This document provides the drafting team's justification for assignment of violation risk factors (VRFs) and violation severity levels (VSLs) for each requirement in: PRC-026-1 – Relay Performance During Stable Power Swings.

Each primary requirement is assigned a VRF and a set of one or more VSLs. These elements support the determination of an initial value range for the Base Penalty Amount regarding violations of requirements in FERC-approved Reliability Standards, as defined in the ERO Sanction Guidelines.

The Protection System Response to Power Swings Standard Drafting Team applied the following NERC criteria and FERC Guidelines when proposing VRFs and VSLs for the requirements under this project.

### **NERC Criteria - Violation Risk Factors**

#### ***High Risk Requirement***

A requirement that, if violated, could directly cause or contribute to bulk electric system instability, separation, or a cascading sequence of failures, or could place the bulk electric system at an unacceptable risk of instability, separation, or cascading failures; or, a requirement in a planning time frame that, if violated, could, under emergency, abnormal, or restorative conditions anticipated by the preparations, directly cause or contribute to bulk electric system instability, separation, or a cascading sequence of failures, or could place the bulk electric system at an unacceptable risk of instability, separation, or cascading failures, or could hinder restoration to a normal condition.

#### ***Medium Risk Requirement***

A requirement that, if violated, could directly affect the electrical state or the capability of the bulk electric system, or the ability to effectively monitor and control the bulk electric system. However, violation of a medium risk requirement is unlikely to lead to bulk electric system instability, separation, or cascading failures; or, a requirement in a planning time frame that, if violated, could, under emergency, abnormal, or restorative conditions anticipated by the preparations, directly and adversely affect the electrical state or capability of the bulk electric system, or the ability to effectively monitor, control, or restore the bulk electric system.

However, violation of a medium risk requirement is unlikely, under emergency, abnormal, or restoration conditions anticipated by the preparations, to lead to bulk electric system instability, separation, or cascading failures, nor to hinder restoration to a normal condition.

### ***Lower Risk Requirement***

A requirement that is administrative in nature and a requirement that, if violated, would not be expected to adversely affect the electrical state or capability of the bulk electric system, or the ability to effectively monitor and control the bulk electric system; or, a requirement that is administrative in nature and a requirement in a planning time frame that, if violated, would not, under the emergency, abnormal, or restorative conditions anticipated by the preparations, be expected to adversely affect the electrical state or capability of the bulk electric system, or the ability to effectively monitor, control, or restore the bulk electric system. A planning requirement that is administrative in nature.

### **FERC Violation Risk Factor Guidelines**

The standard drafting team (SDT) also considered consistency with the FERC Violation Risk Factor Guidelines for setting VRFs:<sup>1</sup>

#### **Guideline (1) — Consistency with the Conclusions of the Final Blackout Report**

The Commission seeks to ensure that Violation Risk Factors assigned to Requirements of Reliability Standards in these identified areas appropriately reflect their historical critical impact on the reliability of the Bulk-Power System.

In the VSL Order, FERC listed critical areas (from the Final Blackout Report) where violations could severely affect the reliability of the Bulk-Power System:<sup>2</sup>

- Emergency operations
- Vegetation management
- Operator personnel training
- Protection systems and their coordination
- Operating tools and backup facilities
- Reactive power and voltage control
- System modeling and data exchange
- Communication protocol and facilities
- Requirements to determine equipment ratings
- Synchronized data recorders
- Clearer criteria for operationally critical facilities
- Appropriate use of transmission loading relief

#### **Guideline (2) — Consistency within a Reliability Standard**

<sup>1</sup> North American Electric Reliability Corp., 119 FERC ¶ 61,145, order on reh'g and compliance filing, 120 FERC ¶ 61,145 (2007) ("VRF Rehearing Order").

<sup>2</sup> Id. at footnote 15.

The Commission expects a rational connection between the sub-Requirement Violation Risk Factor assignments and the main Requirement Violation Risk Factor assignment.

**Guideline (3) – Consistency among Reliability Standards**

The Commission expects the assignment of Violation Risk Factors corresponding to Requirements that address similar reliability goals in different Reliability Standards would be treated comparably.

**Guideline (4) – Consistency with NERC’s Definition of the Violation Risk Factor Level**

Guideline (4) was developed to evaluate whether the assignment of a particular Violation Risk Factor level conforms to NERC’s definition of that risk level.

**Guideline (5) – Treatment of Requirements that Co-mingle More Than One Obligation**

Where a single Requirement co-mingles a higher risk reliability objective and a lesser risk reliability objective, the VRF assignment for such Requirements must not be watered down to reflect the lower risk level associated with the less important objective of the Reliability Standard.

**NERC Criteria - Violation Severity Levels**

Violation Severity Levels (VSLs) define the degree to which compliance with a requirement was not achieved. Each requirement must have at least one VSL. While it is preferable to have four VSLs for each requirement, some requirements do not have multiple “degrees” of noncompliant performance and may have only one, two, or three VSLs.

Violation severity levels should be based on the guidelines shown in the table below:

Lower	Moderate	High	Severe
Missing a minor element (or a small percentage) of the required performance The performance or product measured has significant value as it almost meets the full intent of the requirement.	Missing at least one significant element (or a moderate percentage) of the required performance. The performance or product measured still has significant value in meeting the intent of the requirement.	Missing more than one significant element (or is missing a high percentage) of the required performance or is missing a single vital component. The performance or product has limited value in meeting the intent of the requirement.	Missing most or all of the significant elements (or a significant percentage) of the required performance. The performance measured does not meet the intent of the requirement or the product delivered cannot be used in meeting the intent of the requirement.



***FERC Order on Violation Severity Levels***

In its June 19, 2008 Order on Violation Severity Levels, FERC indicated it would use the following four guidelines for determining whether to approve VSLs:

***Guideline 1: Violation Severity Level Assignments Should Not Have the Unintended Consequence of Lowering the Current Level of Compliance***

Compare the VSLs to any prior Levels of Non-compliance and avoid significant changes that may encourage a lower level of compliance than was required when Levels of Non-compliance were used.

***Guideline 2: Violation Severity Level Assignments Should Ensure Uniformity and Consistency in the Determination of Penalties***

Guideline 2a: A violation of a “binary” type requirement must be a “Severe” VSL.

Guideline 2b: Do not use ambiguous terms such as “minor” and “significant” to describe noncompliant performance.

***Guideline 3: Violation Severity Level Assignment Should Be Consistent with the Corresponding Requirement***

VSLs should not expand on what is required in the requirement.

***Guideline 4: Violation Severity Level Assignment Should Be Based on A Single Violation, Not on A Cumulative Number of Violations***

. . . unless otherwise stated in the requirement, each instance of non-compliance with a requirement is a separate violation. Section 4 of the Sanction Guidelines states that assessing penalties on a per violation per day basis is the “default” for penalty calculations.

VRF and VSL Justifications – PRC-026-1, R1	
Proposed VRF	Medium
NERC VRF Discussion	<p>A Violation Risk Factor of Medium is consistent with the NERC VRF Guidelines:</p> <p>A failure to notify the respective Generator Owner or Transmission Owner of the <b>BES</b> Element(s) that meet the Requirement R1 criteria prohibits further evaluation of any load-responsive protective relay applied at the terminal of the Element(s). A load-responsive protective relay that goes without evaluation may not be secure for a stable power swing and could, in the planning time frame, under emergency, abnormal, or restorative conditions anticipated by the preparations, directly and adversely affect the electrical state or capability of the bulk electric system, or the ability to effectively monitor, control, or restore the bulk electric system.</p> <p><del>Identifying an Element for notification that is expected to encounter stable power swings based on Requirement R1 criteria is the first step in ensuring the reliable operation of the Bulk Electric System (BES) and in preventing the future severity of disturbances from affecting a wider area.</del></p>
FERC VRF G1 Discussion	<p>Guideline 1- Consistency w/ Blackout Report:</p> <p>The blackout report and subsequent technical analysis identified that two Bulk Power System (BPS) transmission lines tripped due to protective relay operation in response to stable power swings. The Protection System operations on these lines did not contribute significantly to the overall outcome of the August 14, 2003 system disturbance; however, Protection System operation during stable powers swings could negatively impact system reliability under different operating conditions. Identification and evaluation of BES Elements susceptible to power swings and the subsequent mitigation of load-responsive protective relays applied at the terminals of these BES Elements that do not meet the PRC-026-1 – Attachment B criteria will reduce the likelihood of reoccurrence.</p> <p>This Requirement is consistent with the intent of Recommendation 8: Improve System Protection to Slow or Limit the Spread of Future Cascading Outages. While the actions associated with this recommendation did not focus specifically on the issue of Protection Systems tripping in response to stable power swings, the recommendation does note that “power system protection devices should be set to address the</p>

VRF and VSL Justifications – PRC-026-1, R1	
	specific condition of concern, such as a fault, out-of-step condition, etc., and should not compromise a power system’s inherent physical capability to slow down or stop a cascading event.”
FERC VRF G2 Discussion	<p>Guideline 2- Consistency within a Reliability Standard:</p> <p>The Requirement has a single reliability activity associated with the reliability objective and no sub-Requirement(s) which allows a single VRF to be assigned; therefore no conflict(s) exist.</p>
FERC VRF G3 Discussion	<p>Guideline 3- Consistency among Reliability Standards:</p> <p>The Requirement is consistent with NERC Reliability Standard FAC-014-2, R6 (“...Planning Authority shall identify the subset of multiple contingencies...”) which has a VRF of Medium.</p>
FERC VRF G4 Discussion	<p>Guideline 4- Consistency with NERC Definitions of VRFs:</p> <p>A failure of the Planning Coordinator to notify the respective Generator Owner or Transmission Owner of the BES Element(s) that meet the Requirement R1 criteria prohibits further evaluation of any load-responsive protective relay applied at the terminal of the Element. A load-responsive protective relay that goes without evaluation may not be secure for a stable power swing and could, in the planning time frame, under emergency, abnormal, or restorative conditions anticipated by the preparations, directly and adversely affect the electrical state or capability of the bulk electric system, or the ability to effectively monitor, control, or restore the bulk electric system.</p> <p><del>Identifying an Element for notification that is expected to encounter stable power swings based on the Requirement R1 criteria is the first step in ensuring the reliable operation of the BES and in preventing the future severity of disturbances from affecting a wider area.</del></p>
FERC VRF G5 Discussion	<p>Guideline 5- Treatment of Requirements that Co-mingle More than One Obligation:</p> <p>This Requirement does not co-mingle reliability objectives of differing risk; therefore, the assigned VRF of Medium is consistent.</p>

VRF and VSL Justifications – PRC-026-1, R1			
Proposed VSL			
Lower	Moderate	High	Severe
The Planning Coordinator provided notification of the BES Element(s) in accordance with Requirement R1, but was less than or equal to 30 calendar days late.	The Planning Coordinator provided notification of the BES Element(s) in accordance with Requirement R1, but was more than 30 calendar days and less than or equal to 60 calendar days late.	The Planning Coordinator provided notification of the BES Element(s) in accordance with Requirement R1, but was more than 60 calendar days and less than or equal to 90 calendar days late.	The Planning Coordinator provided notification of the BES Element(s) in accordance with Requirement R1, but was more than 90 calendar days late.  OR The Planning Coordinator failed to provide notification of the BES Element(s) in accordance with Requirement R1.
NERC VSL Guidelines	Meets NERC’s VSL Guidelines—There is an incremental aspect to the VSL for tardiness and a binary aspect for failure. The VSL is entity size-neutral because performance is Element-driven and not by the total assets which an entity may have awareness over.		
FERC VSL G1 Violation Severity Level Assignments Should Not Have the Unintended Consequence of Lowering the Current Level of Compliance	The proposed VSL does not lower the current level of compliance because the Requirement is new.		

VRF and VSL Justifications – PRC-026-1, R1

<p>FERC VSL G2</p> <p>Violation Severity Level Assignments Should Ensure Uniformity and Consistency in the Determination of Penalties</p> <p>Guideline 2a: The Single Violation Severity Level Assignment Category for "Binary" Requirements Is Not Consistent</p> <p>Guideline 2b: Violation Severity Level Assignments that Contain Ambiguous Language</p>	<p>Guideline 2a:</p> <p>This Requirement is <del>not binary; therefore, this criterion does not apply</del> and utilizes a VSL of Severe for <u>failure in addition to incremental VSLs for tardiness.</u></p> <p>Guideline 2b:</p> <p>The proposed VSL does not use any ambiguous terminology, thereby supporting uniformity and consistency in the determination of similar penalties for similar violations.</p>
<p>FERC VSL G3</p> <p>Violation Severity Level Assignment Should Be Consistent with the Corresponding Requirement</p>	<p>The proposed VSL uses similar terminology to that used in the corresponding Requirement, and is therefore consistent with the Requirement.</p>
<p>FERC VSL G4</p> <p>Violation Severity Level Assignment Should Be Based on A Single Violation, Not on A Cumulative Number of Violations</p>	<p>The VSL is based on a single violation and not cumulative violations.</p>

VRF and VSL Justifications – PRC-026-1, R2

Proposed VRF	High
NERC VRF Discussion	<p>A Violation Risk Factor of High is consistent with the NERC VRF Guidelines:</p> <p>A failure to evaluate the Protection System to determine that it is expected to not trip for a stable power swing for a BES Element could, under emergency, abnormal, or restorative conditions anticipated by the preparations, directly cause or contribute to bulk electric system instability, separation, or a cascading sequence of failures, or could place the bulk electric system at an unacceptable risk of instability, separation, or cascading failures, or could hinder restoration to a normal condition.</p> <p>A Protection System that does not meet the PRC-026-1 – Attachment B criteria is less secure during stable power swings, which increases the risk of tripping should the Protection System be challenged by a power swing.</p>
FERC VRF G1 Discussion	<p>Guideline 1- Consistency w/ Blackout Report:</p> <p>The blackout report and subsequent technical analysis identified that two bulk power system (BPS) transmission lines tripped due to protective relay operation in response to stable power swings. The Protection System operations on these lines did not contribute significantly to the overall outcome of the August 14, 2003 system disturbance; however, Protection System operation during stable powers swings could negatively impact system reliability under different operating conditions. Evaluation of load-responsive protective relays applied at the terminals of identified BES Elements will allow the Generator Owner and Transmission Owner to determine whether the load-responsive protective relays meet the PRC-026-1 – Attachment B criteria.</p> <p>This Requirement is consistent with the intent of Recommendation 8: Improve System Protection to Slow or Limit the Spread of Future Cascading Outages. While the actions associated with this recommendation did not focus specifically on this issue of Protection Systems tripping in response to stable power swings, the recommendation does note that “power system protection devices should be set to address the specific condition of concern, such as a fault, out-of-step condition, etc., and should not compromise a power system’s inherent physical capability to slow down or stop a cascading event.”</p>

VRF and VSL Justifications – PRC-026-1, R2	
FERC VRF G2 Discussion	<p>Guideline 2- Consistency within a Reliability Standard:</p> <p>The Requirement has a single reliability activity associated with the reliability objective and no sub-Requirement(s) which allows a single VRF to be assigned; therefore no conflict(s) exist.</p>
FERC VRF G3 Discussion	<p>Guideline 3- Consistency among Reliability Standards:</p> <p>The Requirement is consistent with NERC Reliability Standard PRC-023-3, R1 (“...Each Transmission Owner, Generator Owner, and Distribution Provider shall evaluate relay loadability at 0.85 per unit voltage and a power factor angle of 30 degrees”) which has a VRF of High.</p>
FERC VRF G4 Discussion	<p>Guideline 4- Consistency with NERC Definitions of VRFs:</p> <p>A failure of the Generator Owner or Transmission Owner to evaluate that the Protection System is expected to not trip in response to a stable power swing during a non-Fault condition for a BES Element could, under emergency, abnormal, or restorative conditions anticipated by the preparations, directly cause or contribute to bulk electric system instability, separation, or a cascading sequence of failures, or could place the bulk electric system at an unacceptable risk of instability, separation, or cascading failures, or could hinder restoration to a normal condition.</p> <p>A Protection System that does not meet the PRC-026-1 – Attachment B criteria is less secure during stable power swings, it increases the risk of tripping should the Protection System be challenged by a power swing.</p>
FERC VRF G5 Discussion	<p>Guideline 5- Treatment of Requirements that Co-mingle More than One Obligation:</p> <p>This Requirement does not co-mingle reliability objectives of differing risk; therefore, the assigned VRF of Medium is consistent.</p>

VRF and VSL Justifications – PRC-026-1, R2			
Proposed VSL			
Lower	Moderate	High	Severe
The Generator Owner or Transmission Owner evaluated its load-responsive protective relay(s) in accordance with Requirement R2, but was less than or equal to 30 calendar days late.	The Generator Owner or Transmission Owner evaluated its load-responsive protective relay(s) in accordance with Requirement R2, but was more than 30 calendar days and less than or equal to 60 calendar days late.	The Generator Owner or Transmission Owner evaluated its load-responsive protective relay(s) in accordance with Requirement R2, but was more than 60 calendar days and less than or equal to 90 calendar days late.	The Generator Owner or Transmission Owner evaluated its load-responsive protective relay(s) in accordance with Requirement R2, but was more than 90 calendar days late.  OR The Generator Owner or Transmission Owner failed to evaluate its load-responsive protective relay(s) in accordance with Requirement R2.
NERC VSL Guidelines	Meets NERC’s VSL Guidelines—There is an incremental aspect to the VSL for tardiness and a binary aspect for failure. The VSL is entity size-neutral because performance is driven by exception. For example, each identified Element must be evaluated.		
FERC VSL G1 Violation Severity Level Assignments Should Not Have the Unintended Consequence of Lowering the Current Level of Compliance	The proposed VSL does not lower the current level of compliance because the Requirement is new.		



VRF and VSL Justifications – PRC-026-1, R2

<p>FERC VSL G2</p> <p>Violation Severity Level Assignments Should Ensure Uniformity and Consistency in the Determination of Penalties</p> <p>Guideline 2a: The Single Violation Severity Level Assignment Category for "Binary" Requirements Is Not Consistent</p> <p>Guideline 2b: Violation Severity Level Assignments that Contain Ambiguous Language</p>	<p>Guideline 2a:</p> <p>This Requirement is not binary; therefore, this criterion does not apply.</p> <p>Guideline 2b:</p> <p>The proposed VSL does not use any ambiguous terminology, thereby supporting uniformity and consistency in the determination of similar penalties for similar violations.</p>
<p>FERC VSL G3</p> <p>Violation Severity Level Assignment Should Be Consistent with the Corresponding Requirement</p>	<p>The proposed VSL uses similar terminology to that used in the corresponding Requirement, and is therefore consistent with the Requirement.</p>
<p>FERC VSL G4</p> <p>Violation Severity Level Assignment Should Be Based on A Single Violation, Not on A Cumulative Number of Violations</p>	<p>The VSL is based on a single violation and not cumulative violations.</p>

VRF and VSL Justifications – PRC-004-3, R3

Proposed VRF	Medium
<p>NERC VRF Discussion</p>	<p>A Violation Risk Factor of Medium is consistent with the NERC VRF Guidelines:</p> <p>Failure to develop a Corrective Action Plan (CAP) such that the Protection System of a BES Element will meet the PRC-026-1 – Attachment B criteria or to exclude the Protection System under the PRC-026-1 – Attachment A criteria (e.g., modifying the Protection System so that relay functions are supervised by power swing blocking or using relay systems that are immune to power swings) could in the planning time frame, under emergency, abnormal, or restorative conditions anticipated by the preparations, directly and adversely affect the electrical state or capability of the bulk electric system, or the ability to effectively monitor, control, or restore the bulk electric system.</p> <p><del>An unmitigated Protection System could affect the electrical state or capability of the bulk electric system, or the ability to effectively monitor, control, or restore the bulk electric system.</del></p>
<p>FERC VRF G1 Discussion</p>	<p>Guideline 1- Consistency w/ Blackout Report:</p> <p>The blackout report and subsequent technical analysis identified that two bulk power system (BPS) transmission lines tripped due to protective relay operation in response to stable power swings. The Protection System operations on these lines did not contribute significantly to the overall outcome of the August 14, 2003 system disturbance; however, Protection System operation during stable powers swings could negatively impact system reliability under different operating conditions. Developing a CAP such that the Protection System will meet the Attachment B criteria or to exclude the Protection System under the PRC-026-1 – Attachment A criteria (e.g., modifying the Protection System so that relay functions are supervised by power swing blocking or using relay systems that are immune to power swings) applied at the terminals of BES Elements will reduce the likelihood of reoccurrence.</p>

VRF and VSL Justifications – PRC-004-3, R3	
	<p>This Requirement is consistent with the intent of Recommendation 8: Improve System Protection to Slow or Limit the Spread of Future Cascading Outages. While the actions associated with this recommendation did not focus specifically on this issue of Protection Systems tripping in response to stable power swings, the recommendation does note that “power system protection devices should be set to address the specific condition of concern, such as a fault, out-of-step condition, etc., and should not compromise a power system’s inherent physical capability to slow down or stop a cascading event.”</p>
FERC VRF G2 Discussion	<p>Guideline 2- Consistency within a Reliability Standard:</p> <p>This Requirement has a single reliability activity associated with the reliability objective and no sub-Requirement(s) which allows a single VRF to be assigned; therefore no conflict(s) exist.</p>
FERC VRF G3 Discussion	<p>Guideline 3- Consistency among Reliability Standards:</p> <p>This Requirement is consistent with the following Reliability Standards which <del>requiring</del><u>require</u> corrective actions (e.g., Corrective Action Plans); PRC-016-0.1, R2 (“...shall take corrective actions to avoid future Misoperations”), PRC-022-1, R1.5 (“For any Misoperation, a Corrective Action Plan...”), and FAC-003, R5 (“...Transmission Owner or applicable Generator Owner shall take corrective action to ensure continued vegetation management”) all three of which have a VRF of Medium.</p>
FERC VRF G4 Discussion	<p>Guideline 4- Consistency with NERC Definitions of VRFs:</p> <p>A Violation Risk Factor of Medium is consistent with the NERC VRF Guidelines:</p> <p>A failure to develop the Corrective Action Plan (CAP) such that the Protection System of a BES Element will meet the Attachment B criteria or to exclude the Protection System under the PRC-026-1 – Attachment A criteria (e.g., modifying the Protection System so that relay functions are supervised by power swing blocking or using relay systems that are immune to power swings) could, in the planning time frame, under emergency, abnormal, or restorative conditions anticipated by the preparations, directly and adversely affect the electrical state or capability of the bulk electric system, or the ability to effectively monitor, control, or restore the bulk electric system.</p>

VRF and VSL Justifications – PRC-004-3, R3			
	<del>An unmitigated Protection System could contribute to the severity of future disturbances affecting a wider area, or potential equipment damage.</del>		
FERC VRF G5 Discussion	<p>Guideline 5- Treatment of Requirements that Co-mingle More than One Obligation:</p> <p>This requirement does not co-mingle reliability objectives of differing risk; therefore, the assigned VRF of Medium is consistent.</p>		
Proposed VSL			
Lower	Moderate	High	Severe
The Generator Owner or Transmission Owner developed a Corrective Action Plan (CAP) in accordance with Requirement R3, but in more than six calendar months and less than or equal to seven calendar months.	The Generator Owner or Transmission Owner developed a Corrective Action Plan (CAP) in accordance with Requirement R3, but in more than seven calendar months and less than or equal to eight calendar months.	The Generator Owner or Transmission Owner developed a Corrective Action Plan (CAP) in accordance with Requirement R3, but in more than eight calendar months and less than or equal to nine calendar months.	<p>The Generator Owner or Transmission Owner developed a Corrective Action Plan (CAP) in accordance with Requirement R3, but in more than nine calendar months.</p> <p>OR</p> <p>The Generator Owner or Transmission Owner failed to develop a CAP in accordance with Requirement R3.</p>
NERC VSL Guidelines	Meets NERC’s VSL Guidelines—There is an incremental aspect to the VSL for failing to develop the Corrective Action Plan in a timely fashion and a binary aspect for a complete failure. The VSL is entity size-neutral because performance is driven by the need to mitigate the Protection System so that it is expected to not trip on a stable power swing.		

VRF and VSL Justifications – PRC-004-3, R3

<p>FERC VSL G1</p> <p>Violation Severity Level Assignments Should Not Have the Unintended Consequence of Lowering the Current Level of Compliance</p>	<p>The proposed VSL does not lower the current level of compliance because the Requirement is new.</p>
<p>FERC VSL G2</p> <p>Violation Severity Level Assignments Should Ensure Uniformity and Consistency in the Determination of Penalties</p> <p>Guideline 2a: The Single Violation Severity Level Assignment Category for "Binary" Requirements Is Not Consistent</p> <p>Guideline 2b: Violation Severity Level Assignments that Contain Ambiguous Language</p>	<p>Guideline 2a:</p> <p>This Requirement is <del>not binary; therefore, this criterion does not apply</del> and utilizes a VSL of Severe for <u>failure in addition to incremental VSLs for tardiness.</u></p> <p>Guideline 2b:</p> <p>This proposed VSL does not use any ambiguous terminology, thereby supporting uniformity and consistency in the determination of similar penalties for similar violations.</p>
<p>FERC VSL G3</p> <p>Violation Severity Level Assignment Should Be Consistent with the Corresponding Requirement</p>	<p>This proposed VSL uses similar terminology to that used in the corresponding Requirement, and is therefore consistent with this Requirement.</p>
<p>FERC VSL G4</p>	<p>The VSL is based on a single violation and not cumulative violations.</p>

VRF and VSL Justifications – PRC-004-3, R3

Violation Severity Level  
Assignment Should Be Based on  
A Single Violation, Not on A  
Cumulative Number of  
Violations

VRF and VSL Justifications – PRC-026-1, R4

Proposed VRF	Medium
NERC VRF Discussion	<p>A Violation Risk Factor of Medium is consistent with the NERC VRF Guidelines:</p> <p>A failure to implement the Corrective Action Plan (CAP) to meet the PRC-026-1 – Attachment B criteria or to exclude the Protection System under the PRC-026-1 – Attachment A criteria (e.g., modifying the Protection System so that relay functions are supervised by power swing blocking or using relay systems that are immune to power swings) could, in the planning time frame, under emergency, abnormal, or restorative conditions anticipated by the preparations, directly and adversely affect the electrical state or capability of the bulk electric system, or the ability to effectively monitor, control, or restore the bulk electric system.</p> <p><del>An unmitigated Protection System could affect the electrical state or capability of the bulk electric system, or the ability to effectively monitor, control, or restore the bulk electric system.</del></p>
FERC VRF G1 Discussion	<p>Guideline 1- Consistency w/ Blackout Report:</p> <p>The blackout report and subsequent technical analysis identified that two bulk power system (BPS) transmission lines tripped due to protective relay operation in response to stable power swings. The Protection System operations on these lines did not contribute significantly to the overall outcome of the August 14, 2003 system disturbance; however, Protection System operation during stable powers swings</p>

VRF and VSL Justifications – PRC-026-1, R4

	<p>could negatively impact system reliability under different operating conditions. Implementing a CAP such that the Protection System will meet the Attachment B criteria or to exclude the Protection System under the PRC-026-1 – Attachment A criteria (e.g., modifying the Protection System so that relay functions are supervised by power swing blocking or using relay systems that are immune to power swings) applied at the terminals of these Elements will reduce the likelihood of reoccurrence.</p> <p>This Requirement is consistent with the intent of Recommendation 8: Improve System Protection to Slow or Limit the Spread of Future Cascading Outages. While the actions associated with this recommendation did not focus specifically on this issue of Protection Systems tripping in response to stable power swings, the recommendation does note that “power system protection devices should be set to address the specific condition of concern, such as a fault, out-of-step condition, etc., and should not compromise a power system’s inherent physical capability to slow down or stop a cascading event.”</p>
<p>FERC VRF G2 Discussion</p>	<p>Guideline 2- Consistency within a Reliability Standard:</p> <p>The Requirement has a single reliability activity associated with the reliability objective and no sub-Requirement(s) which allows a single VRF to be assigned; therefore no conflict(s) exist.</p>
<p>FERC VRF G3 Discussion</p>	<p>Guideline 3- Consistency among Reliability Standards:</p> <p>This Requirement is consistent with the following Reliability Standards which <del>requiring</del><u>require</u> corrective actions (e.g., Corrective Action Plans): PRC-016-0.1, R2 (“...shall take corrective actions to avoid future Misoperations”), PRC-022-1, R1.5 (“For any Misoperation, a Corrective Action Plan...”), and FAC-003, R5 (“...Transmission Owner or applicable Generator Owner shall take corrective action to ensure continued vegetation management”) all of which have a VRF of Medium.</p>
<p>FERC VRF G4 Discussion</p>	<p>A Violation Risk Factor of Medium is consistent with the NERC VRF Guidelines:</p> <p>A failure to implement the Corrective Action Plan such that the Protection System of a BES Element will meet the Attachment B criteria or to exclude the Protection System under the PRC-026-1 – Attachment A criteria (e.g., modifying the Protection System so that relay functions are supervised by power swing blocking or using relay systems that are immune to power swings) could, in the planning time frame, under emergency, abnormal, or restorative conditions anticipated by the preparations, directly and</p>

VRF and VSL Justifications – PRC-026-1, R4			
	<p>adversely affect the electrical state or capability of the bulk electric system, or the ability to effectively monitor, control, or restore the bulk electric system.</p> <p><del>An unmitigated Protection System could contribute to the severity of future disturbances affecting a wider area, or potential equipment damage.</del></p>		
FERC VRF G5 Discussion	<p>Guideline 5- Treatment of Requirements that Co-mingle More than One Obligation:</p> <p>This Requirement does not co-mingle reliability objectives of differing risk; therefore, the assigned VRF of Medium is consistent.</p>		
Proposed VSL			
Lower	Moderate	High	Severe
The responsible entity implemented, but failed to update a CAP, when actions or timetables changed, in accordance with Requirement R4.	N/A	N/A	The responsible entity failed to implement a CAP in accordance with Requirement R4.
NERC VSL Guidelines	<p>Meets NERC’s VSL Guidelines—There is an incremental aspect to the VSL for failing to update the Corrective Action Plan and a binary aspect for failure to implement. The VSL is entity size-neutral because performance is driven by the need to mitigate the Protection System so that it is expected to not trip on a stable power swing.</p>		
FERC VSL G1 Violation Severity Level Assignments Should Not Have	<p>The proposed VSL does not lower the current level of compliance because the Requirement is new.</p>		



VRF and VSL Justifications – PRC-026-1, R4

<p>the Unintended Consequence of Lowering the Current Level of Compliance</p>	
<p>FERC VSL G2 Violation Severity Level Assignments Should Ensure Uniformity and Consistency in the Determination of Penalties Guideline 2a: The Single Violation Severity Level Assignment Category for "Binary" Requirements Is Not Consistent Guideline 2b: Violation Severity Level Assignments that Contain Ambiguous Language</p>	<p>Guideline 2a: This Requirement is not binary; therefore, this criterion does not apply.  Guideline 2b: The proposed VSL does not use any ambiguous terminology, thereby supporting uniformity and consistency in the determination of similar penalties for similar violations.</p>
<p>FERC VSL G3 Violation Severity Level Assignment Should Be Consistent with the Corresponding Requirement</p>	<p>The proposed VSL uses similar terminology to that used in the corresponding Requirement, and is therefore consistent with the Requirement.</p>
<p>FERC VSL G4 Violation Severity Level Assignment Should Be Based on A Single Violation, Not on A</p>	<p>The VSL is based on a single violation and not cumulative violations.</p>

VRF and VSL Justifications – PRC-026-1, R4

Cumulative Number of Violations	
---------------------------------	--

## Table of Issues and Directives

### Project 2010-13.3 – Relay Loadability: Stable Power Swings

Table of Issues and Directives Associated with PRC-026-1

Source	Issue or Directive Language (including Para. #)	Section and/or Requirement(s)	Consideration of Issue or Directive
FERC Order 733	<b>150.</b> We will not direct the ERO to modify PRC-023-1 to address stable power swings. However, because both NERC and the Task Force have identified undesirable relay operation due to stable power swings as a reliability issue, we direct the ERO to develop a Reliability Standard that requires the use of protective relay systems that can differentiate between faults and stable power swings and, when necessary, phases out protective relay systems that cannot meet this requirement.	All requirements	<p>The PRC-026-1 standard is responsive to this directive by using an equally effective and efficient focused approach for the Planning Coordinator to provide notification of BES Elements according to the Requirement R1 criteria to the respective Generator Owner and Transmission Owner. The criteria used to identify a BES Element are based on the NERC System Protection and Control Subcommittee technical document, <i>Protection System Response to Power Swings</i> (“PSRPS Report”).<sup>1</sup> The specific criteria are based on where power swings are expected to challenge load-responsive protective relays.</p> <p>The criteria include 1) Generator(s) where an angular stability constraint exists that is addressed by a System Operating Limit (SOL) or a Remedial Action Scheme (RAS) and those Elements</p>

<sup>1</sup> NERC System Protection and Control Subcommittee technical document, *Protection System Response to Power Swings*, August 2013: [http://www.nerc.com/comm/PC/System%20Protection%20and%20Control%20Subcommittee%20SPCS%2020/SPCS%20Power%20Swing%20Report\\_Final\\_20131015.pdf](http://www.nerc.com/comm/PC/System%20Protection%20and%20Control%20Subcommittee%20SPCS%2020/SPCS%20Power%20Swing%20Report_Final_20131015.pdf)

<p>We also direct the ERO to file a report no later than 120 days of this Final Rule addressing the issue of protective relay operation due to power swings. The report should include an action plan and timeline that explains how and when the ERO intends to address this issue through its Reliability Standards development process.</p> <p><b>AND</b></p> <p><b>153.</b> While we recognize that addressing stable power swings is a complex issue, we note that more than six years have passed since the August 2003 blackout and there is still no Reliability Standard that addresses relays tripping due to stable power swings. Additionally, NERC has long identified undesirable relay operation due to stable power swings as a reliability issue. Consequently, pursuant to section 215(d)(5) of the FPA, we find that undesirable relay operation due to stable power swings is a specific matter that the ERO must address to carry out the goals of section 215, and we direct the ERO to develop a Reliability Standard</p>	<p>terminating at the Transmission station associated with the generator(s); 2) An Element that is monitored as part of an SOL identified by the Planning Coordinator’s methodology based on an angular stability constraint; 3) An Element that forms the boundary of an island in the most recent underfrequency load shedding (UFLS) design assessment based on application of the Planning Coordinator’s criteria for identifying islands, only if the island is formed by tripping the Element based on angular instability; 4) An Element identified in the most recent annual Planning Assessment where relay tripping occurs due to a stable or unstable power swing during a simulated disturbance.</p> <p>Requirement R2 requires the Generator Owner and Transmission Owner to evaluate their load-responsive protective relays that are applied at all of the terminals of each BES Element identified by the Planning Coordinator in Requirement R1 or upon becoming aware of a generator, transformer, or transmission line BES Element that tripped in response to a stable or unstable power swing due to the operation of their protective relay(s). The initial evaluation allows the Generator Owner and Transmission Owner to determine whether their load-responsive protective relays applied at all of the terminals of the BES Element meet the PRC-026-1 – Attachment B criteria. Additionally, the Requirement ensures that the Generator Owner and Transmission Owner must re-evaluate the Protection System</p>
--------------------------------------------------------------------------------------------------------------------------------------------------------------------------------------------------------------------------------------------------------------------------------------------------------------------------------------------------------------------------------------------------------------------------------------------------------------------------------------------------------------------------------------------------------------------------------------------------------------------------------------------------------------------------------------------------------------------------------------------------------------------------------------------------------------------------------------------------------------------------------------------------------------------------------------------------------------------------------------------------------------------------------------------------	---------------------------------------------------------------------------------------------------------------------------------------------------------------------------------------------------------------------------------------------------------------------------------------------------------------------------------------------------------------------------------------------------------------------------------------------------------------------------------------------------------------------------------------------------------------------------------------------------------------------------------------------------------------------------------------------------------------------------------------------------------------------------------------------------------------------------------------------------------------------------------------------------------------------------------------------------------------------------------------------------------------------------------------------------------------------------------------------------------------------------------------------------------------------------------------------------------------------------------------------------------------------------------------------------------------------------------------------------------------------------------------------------------------------------------------------------------------------------------------------------------------------------------------------

	<p>addressing undesirable relay operation due to stable power swings.</p>		<p>on a five year basis should the BES Element continue to be identified by the Planning Coordinator in Requirement R1.</p> <p>Requirement R3 mandates the development of a Corrective Action Plan (CAP) such that the Protection System of a BES Element will meet the PRC-026-1 –Attachment B criteria or the Protection System can be excluded under the PRC-026-1 – Attachment A criteria (e.g., modifying the Protection System so that relay functions are supervised by power swing blocking or using relay systems that are immune to power swings).</p> <p>Requirement R4 mandates that the Generator Owner and Transmission Owner implement each developed CAP in Requirement R3 so that load-responsive protective relays are expected to not trip in response to stable power swings during non-Fault conditions.</p>
	<p><b>162.</b> The PSEG Companies also assert that the Commission’s approach to stable power swings should be inclusive and include “islanding” strategies in conjunction with out-of-step blocking or tripping requirements. We agree with the PSEG Companies and direct the ERO to consider “islanding” strategies that achieve the fundamental performance for all islands in developing the new</p>	<p>Requirement R1, Criterion 3</p>	<p>Islanding strategies were considered during the development of the proposed standard. It was determined that islanding strategies are not an appropriate method to meet the purpose of the proposed standard. Islanding strategies are developed to isolate the system from unstable power swings, which is not prohibited under the proposed standard. The proposed standard’s intent is to ensure that load-responsive protective relays are expected to not trip in response to stable power swings during non-Fault conditions, while maintaining dependable fault detection and dependable out-of-step</p>

	Reliability Standard addressing stable power swings.		tripping (if out-of-step tripping is applied at the terminal of the BES Element).
--	------------------------------------------------------	--	-----------------------------------------------------------------------------------

# Standards Announcement

## Project 2010-13.3 Phase 3 of Relay Loadability: Stable Power Swings

Final Ballot Now Open through December 16, 2014

### [Now Available](#)

A final ballot for **PRC-026-1 – Relay Performance During Stable Power Swings** is open through **8 p.m. Eastern, Monday, December 16, 2014.**

Background information for this project can be found on the [project page](#).

### Instructions for Balloting

In the final ballot, votes are counted by exception. Only members of the ballot pool may cast a ballot; all ballot pool members may change their previously cast votes. A ballot pool member who failed to cast a vote during the last ballot window may cast a vote in the final ballot window. If a ballot pool member cast a vote in the previous ballot and does not participate in the final ballot, that member's vote will be carried over in the final ballot.

Members of the ballot pool associated with this project may log in and submit their vote for the standard by clicking [here](#).

### Next Steps

The voting results for the standard will be posted and announced after the ballot window closes. If approved, it will be submitted to the Board of Trustees for adoption and then filed with the appropriate regulatory authorities.

For information on the **Standards Development Process**, please refer to the [Standard Processes Manual](#).

*For more information or assistance, please contact [Scott Barfield-McGinnis](#), Standards Developer at 404-446-9689.*

North American Electric Reliability Corporation  
3353 Peachtree Rd, NE  
Suite 600, North Tower

Atlanta, GA 30326  
404-446-2560 | [www.nerc.com](http://www.nerc.com)



# Standards Announcement

## Project 2010-13.3 Phase 3 of Relay Loadability: Stable Power Swings PRC-026-1

### Final Ballot Results

#### [Now Available](#)

A final ballot for **PRC-026-1 – Relay Performance During Stable Power Swings** concluded **8 p.m. Eastern on Tuesday, December 16, 2014.**

The standard achieved a quorum and received sufficient affirmative votes for approval. Voting statistics are listed below, and the [Ballot Results](#) page provides a link to the detailed results for the ballot.

Quorum /Approval
84.81% / 68.08%

Background information for this project can be found on the [project page](#).

### Next Steps

The standard will be submitted to the Board of Trustees for adoption and then filed with the appropriate regulatory authorities.

For more information on the **Standards Development Process**, please refer to the [Standard Processes Manual](#).

*For more information or assistance, please contact Standards Developer, [Scott Barfield](#), or by telephone at 404-446-9689.*

North American Electric Reliability Corporation  
3353 Peachtree Rd, NE  
Suite 600, North Tower  
Atlanta, GA 30326  
404-446-2560 | [www.nerc.com](http://www.nerc.com)

Log In

- Ballot Pools
- Current Ballots
- Ballot Results
- Registered Ballot Body
- Proxy Voters
- Register

[Home Page](#)

Ballot Results	
<b>Ballot Name:</b>	Project 2010-13.3 Relay Loadability Stable Power Swings PRC-026-1_Final_Ballot_December_2014
<b>Ballot Period:</b>	12/5/2014 - 12/16/2014
<b>Ballot Type:</b>	Final
<b>Total # Votes:</b>	307
<b>Total Ballot Pool:</b>	362
<b>Quorum:</b>	<b>84.81 % The Quorum has been reached</b>
<b>Weighted Segment Vote:</b>	68.08 %
<b>Ballot Results:</b>	<b>A quorum was reached and there were sufficient affirmative votes for approval.</b>

Summary of Ballot Results										
Segment	Ballot Pool	Segment Weight	Affirmative		Negative		Negative Vote without a Comment	Abstain	No Vote	
			# Votes	Fraction	# Votes	Fraction				
1 - Segment 1	104	1	44	0.62	27	0.38	0	15	18	
2 - Segment 2	9	0.8	6	0.6	2	0.2	0	0	1	
3 - Segment 3	76	1	37	0.698	16	0.302	0	10	13	
4 - Segment 4	25	1	12	0.6	8	0.4	0	3	2	
5 - Segment 5	79	1	35	0.574	26	0.426	0	6	12	
6 - Segment 6	52	1	25	0.61	16	0.39	0	4	7	
7 - Segment 7	2	0.1	0	0	1	0.1	0	0	1	
8 - Segment 8	4	0.3	2	0.2	1	0.1	0	1	0	
9 -										

Segment 9	2	0.2	2	0.2	0	0	0	0	0
10 - Segment 10	9	0.8	8	0.8	0	0	0	0	1
<b>Totals</b>	<b>362</b>	<b>7.2</b>	<b>171</b>	<b>4.902</b>	<b>97</b>	<b>2.298</b>	<b>0</b>	<b>39</b>	<b>55</b>

Individual Ballot Pool Results				
Segment	Organization	Member	Ballot	NERC Notes
1	Ameren Services	Eric Scott	Affirmative	
1	American Electric Power	Paul B Johnson	Affirmative	
1	American Transmission Company, LLC	Andrew Z Pusztai	Affirmative	
1	Arizona Public Service Co.	Robert Smith		
1	Associated Electric Cooperative, Inc.	John Bussman	Negative	SUPPORTS THIRD PARTY COMMENTS
1	ATCO Electric	Glen Sutton	Abstain	
1	Austin Energy	James Armke	Abstain	
1	Avista Utilities	Heather Rosentrater		
1	Balancing Authority of Northern California	Kevin Smith	Affirmative	
1	Baltimore Gas & Electric Company	Christopher J Scanlon	Affirmative	
1	BC Hydro and Power Authority	Patricia Robertson	Negative	COMMENT RECEIVED
1	Black Hills Corp	Wes Wingen	Abstain	
1	Brazos Electric Power Cooperative, Inc.	Tony Kroskey		
1	Bryan Texas Utilities	John C Fontenot	Affirmative	
1	CenterPoint Energy Houston Electric, LLC	John Brockhan	Negative	COMMENT RECEIVED
1	Central Electric Power Cooperative	Michael B Bax	Negative	SUPPORTS THIRD PARTY COMMENTS
1	Central Iowa Power Cooperative	Kevin J Lyons	Affirmative	
1	City of Tacoma, Department of Public Utilities, Light Division, dba Tacoma Power	Chang G Choi	Affirmative	
1	City of Tallahassee	Daniel S Langston	Negative	
1	Clark Public Utilities	Jack Stamper	Affirmative	
1	Colorado Springs Utilities	Shawna Speer	Negative	
1	Consolidated Edison Co. of New York	Christopher L de Graffenried	Affirmative	
1	CPS Energy	Glenn Pressler	Negative	SUPPORTS THIRD PARTY COMMENTS
1	Dairyland Power Coop.	Robert W. Roddy	Abstain	
1	Deseret Power	James Tucker	Abstain	
1	Dominion Virginia Power	Larry Nash	Affirmative	
1	Duke Energy Carolina	Doug E Hils	Negative	SUPPORTS THIRD PARTY COMMENTS
1	Empire District Electric Co.	Ralph F Meyer	Abstain	
1	Encari	Steven E Hamburg		
1	Entergy Transmission	Oliver A Burke	Negative	
1	FirstEnergy Corp.	William J Smith	Affirmative	
1	Florida Keys Electric Cooperative Assoc.	Dennis Minton	Affirmative	
1	Florida Power & Light Co.	Mike O'Neil	Affirmative	
1	Gainesville Regional Utilities	Richard Bachmeier		
1	Georgia Transmission Corporation	Jason Snodgrass	Affirmative	
1	Great River Energy	Gordon Pietsch	Affirmative	
1	Hydro One Networks, Inc.	Muhammed Ali	Affirmative	
1	Hydro-Quebec TransEnergie	Martin Boisvert	Affirmative	
1	Idaho Power Company	Molly Devine	Affirmative	
1	International Transmission Company Holdings Corp	Michael Moltane	Negative	
1	JDRJC Associates	Jim D Cyrulewski	Affirmative	
				COMMENT

1	JEA	Ted E Hobson	Negative	RECEIVED
1	KAMO Electric Cooperative	Walter Kenyon	Negative	SUPPORTS THIRD PARTY COMMENTS
1	Kansas City Power & Light Co.	Daniel Gibson	Negative	COMMENT RECEIVED
1	Keys Energy Services	Stan T Rzad	Negative	NO COMMENT RECEIVED
1	Lakeland Electric	Larry E Watt		
1	Lee County Electric Cooperative	John Chin		
1	Los Angeles Department of Water & Power	faranak sarbaz	Abstain	
1	Lower Colorado River Authority	Martyn Turner	Affirmative	
1	Manitoba Hydro	Jo-Anne M Ross	Affirmative	
1	MEAG Power	Danny Dees	Affirmative	
1	MidAmerican Energy Co.	Terry Harbour	Affirmative	
1	Minnkota Power Coop. Inc.	Daniel L Inman	Abstain	
1	N.W. Electric Power Cooperative, Inc.	Mark Ramsey	Negative	SUPPORTS THIRD PARTY COMMENTS
1	National Grid USA	Michael Jones	Affirmative	
1	NB Power Corporation	Alan MacNaughton	Abstain	
1	Nebraska Public Power District	Jamison Cawley	Negative	
1	New York Power Authority	Bruce Metruck	Affirmative	
1	Northeast Missouri Electric Power Cooperative	Kevin White	Negative	SUPPORTS THIRD PARTY COMMENTS
1	Northeast Utilities	William Temple	Affirmative	
1	Northern Indiana Public Service Co.	Julaine Dyke	Abstain	
1	NorthWestern Energy	John Canavan		
1	Ohio Valley Electric Corp.	Scott R Cunningham	Affirmative	
1	Oklahoma Gas and Electric Co.	Terri Pyle	Negative	
1	Omaha Public Power District	Doug Peterchuck	Negative	SUPPORTS THIRD PARTY COMMENTS
1	Oncor Electric Delivery	Jen Fiegel	Affirmative	
1	Otter Tail Power Company	Daryl Hanson	Negative	SUPPORTS THIRD PARTY COMMENTS
1	Pacific Gas and Electric Company	Bangalore Vijayraghavan		
1	Peak Reliability	Jared Shakespeare		
1	Platte River Power Authority	John C. Collins	Affirmative	
1	Portland General Electric Co.	John T Walker	Affirmative	
1	Potomac Electric Power Co.	David Thorne	Abstain	
1	PPL Electric Utilities Corp.	Brenda L Truhe	Affirmative	
1	Public Service Company of New Mexico	Laurie Williams		
1	Public Service Electric and Gas Co.	Kenneth D. Brown	Negative	COMMENT RECEIVED
1	Public Utility District No. 1 of Okanogan County	Dale Dunckel	Abstain	
1	Puget Sound Energy, Inc.	Denise M Lietz	Affirmative	
1	Rochester Gas and Electric Corp.	John C. Allen	Abstain	
1	Sacramento Municipal Utility District	Tim Kelley	Affirmative	
1	Salt River Project	Robert Kondziolka	Affirmative	
1	SaskPower	Wayne Guttormson	Abstain	
1	Seattle City Light	Pawel Krupa	Negative	SUPPORTS THIRD PARTY COMMENTS
1	Seminole Electric Cooperative, Inc.	Glenn Spurlock	Negative	
1	Sho-Me Power Electric Cooperative	Denise Stevens	Negative	
1	Snohomish County PUD No. 1	Long T Duong	Affirmative	
1	South Carolina Electric & Gas Co.	Tom Hanzlik	Affirmative	
1	South Carolina Public Service Authority	Shawn T Abrams	Abstain	
1	Southern California Edison Company	Steven Mavis	Affirmative	
1	Southern Company Services, Inc.	Robert A. Schaffeld	Affirmative	

1	Southern Illinois Power Coop.	William Hutchison		
1	Southwest Transmission Cooperative, Inc.	John Shaver	Affirmative	
1	Sunflower Electric Power Corporation	Noman Lee Williams		
1	Tampa Electric Co.	Beth Young		
1	Tennessee Valley Authority	Howell D Scott	Affirmative	
1	Trans Bay Cable LLC	Steven Powell	Affirmative	
1	Tri-State Generation & Transmission Association, Inc.	Tracy Sliman	Affirmative	
1	Tucson Electric Power Co.	John Tolo	Negative	
1	U.S. Bureau of Reclamation	Richard T Jackson		
1	United Illuminating Co.	Jonathan Appelbaum	Affirmative	
1	Vermont Electric Power Company, Inc.	Kim Moulton		
1	Westar Energy	Allen Klassen	Negative	SUPPORTS THIRD PARTY COMMENTS
1	Western Area Power Administration	Lloyd A Linke		
1	Wolverine Power Supply Coop., Inc.	Michelle Clements		
1	Xcel Energy, Inc.	Gregory L Pieper	Negative	
2	BC Hydro	Venkataramakrishnan Vinnakota	Negative	SUPPORTS THIRD PARTY COMMENTS
2	California ISO	Rich Vine	Negative	COMMENT RECEIVED
2	Electric Reliability Council of Texas, Inc.	Cheryl Moseley	Affirmative	
2	Independent Electricity System Operator	Leonard Kula	Affirmative	
2	ISO New England, Inc.	Matthew F Goldberg	Affirmative	
2	MISO	Marie Knox	Affirmative	
2	New York Independent System Operator	Gregory Campoli		
2	PJM Interconnection, L.L.C.	stephanie monzon	Affirmative	
2	Southwest Power Pool, Inc.	Charles H. Yeung	Affirmative	
3	AEP	Michael E Deloach	Affirmative	
3	Alabama Power Company	Robert S Moore	Affirmative	
3	Ameren Corp.	David J Jendras	Affirmative	
3	APS	Sarah Kist		
3	Associated Electric Cooperative, Inc.	Todd Bennett	Negative	SUPPORTS THIRD PARTY COMMENTS
3	Atlantic City Electric Company	NICOLE BUCKMAN		
3	Avista Corp.	Scott J Kinney	Abstain	
3	BC Hydro and Power Authority	Pat G. Harrington	Negative	SUPPORTS THIRD PARTY COMMENTS
3	Central Electric Power Cooperative	Adam M Weber	Negative	
3	City of Austin dba Austin Energy	Andrew Gallo	Abstain	
3	City of Clewiston	Lynne Mila	Affirmative	
3	City of Farmington	Linda R Jacobson	Abstain	
3	City of Green Cove Springs	Mark Schultz	Affirmative	
3	City of Redding	Bill Hughes	Affirmative	
3	City of Tallahassee	Bill R Fowler	Abstain	
3	Colorado Springs Utilities	Jean Mueller	Negative	
3	ComEd	John Bee	Affirmative	
3	Consolidated Edison Co. of New York	Peter T Yost	Affirmative	
3	Consumers Energy Company	Gerald G Farringer	Affirmative	
3	Cowlitz County PUD	Russell A Noble		
3	CPS Energy	Jose Escamilla		
3	Delmarva Power & Light Co.	Michael R. Mayer		
3	Dominion Resources, Inc.	Connie B Lowe	Affirmative	
3	DTE Electric	Kent Kujala	Negative	
3	FirstEnergy Corp.	Cindy E Stewart	Affirmative	
3	Florida Keys Electric Cooperative	Tom B Anthony	Abstain	
3	Florida Municipal Power Agency	Joe McKinney	Affirmative	
3	Florida Power & Light Co.	Summer C. Esquerre	Affirmative	
3	Florida Power Corporation	Lee Schuster	Negative	SUPPORTS THIRD PARTY COMMENTS

3	Georgia System Operations Corporation	Scott McGough		
3	Great River Energy	Brian Glover	Affirmative	
3	Hydro One Networks, Inc.	Ayesha Sabouba	Affirmative	
3	JEA	Garry Baker		
3	Kansas City Power & Light Co.	Joshua D Bach	Negative	
3	Lakeland Electric	Mace D Hunter		
3	Lee County Electric Cooperative	David A Hadzima		
3	Lincoln Electric System	Jason Fortik	Negative	SUPPORTS THIRD PARTY COMMENTS
3	Los Angeles Department of Water & Power	Mike Anctil	Abstain	
3	Louisville Gas and Electric Co.	Charles A. Freibert	Affirmative	
3	Manitoba Hydro	Greg C. Parent	Affirmative	
3	MEAG Power	Roger Brand	Affirmative	
3	MidAmerican Energy Co.	Thomas C. Mielnik	Affirmative	
3	Modesto Irrigation District	Jack W Savage	Affirmative	
3	Muscatine Power & Water	John S Bos		
3	National Grid USA	Brian E Shanahan	Affirmative	
3	Nebraska Public Power District	Tony Eddleman	Negative	
3	New York Power Authority	David R Rivera	Affirmative	
3	Northern Indiana Public Service Co.	Ramon J Barany	Abstain	
3	NW Electric Power Cooperative, Inc.	David McDowell		
3	Ocala Utility Services	Randy Hahn	Affirmative	
3	Oklahoma Gas and Electric Co.	Donald Hargrove	Negative	
3	Omaha Public Power District	Blaine R. Dinwiddie	Negative	SUPPORTS THIRD PARTY COMMENTS
3	Orlando Utilities Commission	Ballard K Mutters	Affirmative	
3	Owensboro Municipal Utilities	Thomas T Lyons	Affirmative	
3	Pacific Gas and Electric Company	John H Hagen	Affirmative	
3	Platte River Power Authority	Terry L Baker	Affirmative	
3	PNM Resources	Michael Mertz	Abstain	
3	Portland General Electric Co.	Thomas G Ward	Affirmative	
3	Potomac Electric Power Co.	Mark Yerger	Abstain	
3	Public Service Electric and Gas Co.	Jeffrey Mueller	Negative	SUPPORTS THIRD PARTY COMMENTS
3	Puget Sound Energy, Inc.	Mariah R Kennedy	Affirmative	
3	Sacramento Municipal Utility District	James Leigh-Kendall	Affirmative	
3	Salt River Project	John T. Underhill	Affirmative	
3	Santee Cooper	James M Poston	Abstain	
3	Seattle City Light	Dana Wheelock	Negative	SUPPORTS THIRD PARTY COMMENTS
3	Seminole Electric Cooperative, Inc.	James R Frauen	Negative	
3	Sho-Me Power Electric Cooperative	Jeff L Neas		
3	Snohomish County PUD No. 1	Mark Oens	Affirmative	
3	South Carolina Electric & Gas Co.	Hubert C Young	Affirmative	
3	Southern California Edison Company	Lujuanna Medina	Affirmative	
3	Tacoma Power	Marc Donaldson	Affirmative	
3	Tampa Electric Co.	Ronald L. Donahey		
3	Tennessee Valley Authority	Ian S Grant	Affirmative	
3	Tri-State Generation & Transmission Association, Inc.	Janelle Marriott	Affirmative	
3	Westar Energy	Bo Jones	Negative	SUPPORTS THIRD PARTY COMMENTS
3	Xcel Energy, Inc.	Michael Ibold	Negative	
4	Alliant Energy Corp. Services, Inc.	Kenneth Goldsmith	Negative	SUPPORTS THIRD PARTY COMMENTS
4	Blue Ridge Power Agency	Duane S Dahlquist	Affirmative	
4	City of Austin dba Austin Energy	Reza Ebrahimian	Abstain	
4	City of Redding	Nicholas Zettel	Affirmative	
				SUPPORTS

4	City Utilities of Springfield, Missouri	John Allen	Negative	THIRD PARTY COMMENTS
4	Consumers Energy Company	Tracy Goble	Affirmative	
4	Cowlitz County PUD	Rick Syring		
4	DTE Electric	Daniel Herring	Negative	
4	Florida Municipal Power Agency	Frank Gaffney	Affirmative	
4	Georgia System Operations Corporation	Guy Andrews	Affirmative	
4	Herb Schrayshuen	Herb Schrayshuen	Affirmative	
4	Illinois Municipal Electric Agency	Bob C. Thomas	Abstain	
4	Indiana Municipal Power Agency	Jack Alvey	Negative	SUPPORTS THIRD PARTY COMMENTS
4	Madison Gas and Electric Co.	Joseph DePoorter	Affirmative	
4	Modesto Irrigation District	Spencer Tacke	Negative	COMMENT RECEIVED
4	Ohio Edison Company	Douglas Hohlbaugh	Affirmative	
4	Oklahoma Municipal Power Authority	Ashley Stringer	Abstain	
4	Old Dominion Electric Coop.	Mark Ringhausen	Affirmative	
4	Public Utility District No. 1 of Snohomish County	John D Martinsen	Affirmative	
4	Sacramento Municipal Utility District	Mike Ramirez	Affirmative	
4	Seattle City Light	Hao Li	Negative	SUPPORTS THIRD PARTY COMMENTS
4	Seminole Electric Cooperative, Inc.	Steven R Wallace	Negative	
4	South Mississippi Electric Power Association	Steve McElhane		
4	Tacoma Public Utilities	Keith Morissette	Affirmative	
4	Utility Services, Inc.	Brian Evans-Mongeon	Negative	
5	Amerenue	Sam Dwyer	Affirmative	
5	American Electric Power	Thomas Foltz	Affirmative	
5	Arizona Public Service Co.	Scott Takinen	Affirmative	
5	Associated Electric Cooperative, Inc.	Matthew Pacobit	Negative	SUPPORTS THIRD PARTY COMMENTS
5	BC Hydro and Power Authority	Clement Ma	Negative	SUPPORTS THIRD PARTY COMMENTS
5	Boise-Kuna Irrigation District/dba Lucky peak power plant project	Mike D Kukla		
5	Bonneville Power Administration	Francis J. Halpin	Affirmative	
5	Brazos Electric Power Cooperative, Inc.	Shari Heino	Negative	
5	City and County of San Francisco	Daniel Mason		
5	City of Austin dba Austin Energy	Jeanie Doty	Abstain	
5	City of Redding	Paul A. Cummings	Affirmative	
5	City of Tallahassee	Karen Webb	Negative	
5	City Water, Light & Power of Springfield	Steve Rose		
5	Cleco Power	Stephanie Huffman	Negative	SUPPORTS THIRD PARTY COMMENTS
5	Cogentrix Energy Power Management, LLC	Mike D Hirst	Negative	
5	Colorado Springs Utilities	Kaleb Brimhall	Negative	
5	Con Edison Company of New York	Brian O'Boyle	Affirmative	
5	Consumers Energy Company	David C Greyerbiehl	Affirmative	
5	Cowlitz County PUD	Bob Essex		
5	Dairyland Power Coop.	Tommy Drea	Negative	SUPPORTS THIRD PARTY COMMENTS
5	Dominion Resources, Inc.	Mike Garton	Affirmative	
5	DTE Electric	Mark Stefaniak	Negative	SUPPORTS THIRD PARTY COMMENTS
5	Duke Energy	Dale Q Goodwine	Negative	SUPPORTS THIRD PARTY COMMENTS

5	Dynegy Inc.	Dan Roethemeyer	Abstain	
5	E.ON Climate & Renewables North America, LLC	Dana Showalter		
5	Entergy Services, Inc.	Tracey Stubbs		
5	Exelon Nuclear	Mark F Draper	Affirmative	
5	First Wind	John Robertson	Negative	SUPPORTS THIRD PARTY COMMENTS
5	FirstEnergy Solutions	Kenneth Dresner	Affirmative	
5	Florida Municipal Power Agency	David Schumann	Affirmative	
5	Great River Energy	Preston L Walsh	Affirmative	
5	Hydro-Québec Production	Roger Dufresne	Affirmative	
5	Ingleside Cogeneration LP	Michelle R DAntuono	Negative	
5	JEA	John J Babik	Negative	COMMENT RECEIVED
5	Kansas City Power & Light Co.	Brett Holland	Negative	
5	Kissimmee Utility Authority	Mike Blough	Affirmative	
5	Lakeland Electric	James M Howard	Affirmative	
5	Liberty Electric Power LLC	Daniel Duff	Negative	SUPPORTS THIRD PARTY COMMENTS
5	Lincoln Electric System	Dennis Florom	Negative	SUPPORTS THIRD PARTY COMMENTS
5	Los Angeles Department of Water & Power	Kenneth Silver	Abstain	
5	Lower Colorado River Authority	Dixie Wells	Affirmative	
5	Luminant Generation Company LLC	Rick Terrill	Negative	
5	Manitoba Hydro	Chris Mazur	Affirmative	
5	Massachusetts Municipal Wholesale Electric Company	David Gordon	Abstain	
5	MEAG Power	Steven Grego	Affirmative	
5	Muscatine Power & Water	Mike Avesing	Negative	
5	Nebraska Public Power District	Don Schmit	Negative	SUPPORTS THIRD PARTY COMMENTS
5	New York Power Authority	Wayne Sipperly	Affirmative	
5	NextEra Energy	Allen D Schriver	Affirmative	
5	North Carolina Electric Membership Corp.	Jeffrey S Brame	Affirmative	
5	Northern Indiana Public Service Co.	Michael D Melvin	Abstain	
5	Oglethorpe Power Corporation	Bernard Johnson	Affirmative	
5	Oklahoma Gas and Electric Co.	Henry L Staples	Negative	
5	Omaha Public Power District	Mahmood Z. Safi	Negative	SUPPORTS THIRD PARTY COMMENTS
5	Pacific Gas and Electric Company	Alex Chua		
5	Platte River Power Authority	Christopher R Wood	Affirmative	
5	Portland General Electric Co.	Matt E. Jastram	Affirmative	
5	PPL Generation LLC	Annette M Bannon	Negative	SUPPORTS THIRD PARTY COMMENTS
5	PSEG Fossil LLC	Tim Kucey	Negative	SUPPORTS THIRD PARTY COMMENTS
5	Public Utility District No. 1 of Lewis County	Steven Grega		
5	Public Utility District No. 2 of Grant County, Washington	Michiko Sell		
5	Puget Sound Energy, Inc.	Lynda Kupfer	Affirmative	
5	Sacramento Municipal Utility District	Susan Gill-Zobitz	Affirmative	
5	Salt River Project	William Alkema	Affirmative	
5	Santee Cooper	Lewis P Pierce	Abstain	
5	Seattle City Light	Michael J. Haynes	Negative	SUPPORTS THIRD PARTY COMMENTS
5	Snohomish County PUD No. 1	Sam Nietfeld	Affirmative	



5	South Carolina Electric & Gas Co.	Edward Magic	Affirmative	
5	Southern California Edison Company	Denise Yaffe	Affirmative	
5	Southern Company Generation	William D Shultz	Affirmative	
5	Tacoma Power	Chris Mattson	Affirmative	
5	Tampa Electric Co.	RJames Rocha	Affirmative	
5	Tenaska, Inc.	Scott M. Helyer		
5	Tennessee Valley Authority	David Thompson	Affirmative	
5	Tri-State Generation & Transmission Association, Inc.	Mark Stein	Affirmative	
5	U.S. Army Corps of Engineers	Melissa Kurtz		
5	USDI Bureau of Reclamation	Erika Doot		
5	Westar Energy	Bryan Taggart	Negative	SUPPORTS THIRD PARTY COMMENTS
5	Xcel Energy, Inc.	Mark A Castagneri	Negative	COMMENT RECEIVED
6	AEP Marketing	Edward P. Cox	Affirmative	
6	Ameren Missouri	Robert Quinlivan	Affirmative	
6	APS	Randy A. Young	Negative	
6	Associated Electric Cooperative, Inc.	Brian Ackermann	Negative	SUPPORTS THIRD PARTY COMMENTS
6	Bonneville Power Administration	Brenda S. Anderson	Affirmative	
6	City of Austin dba Austin Energy	Lisa Martin	Abstain	
6	City of Redding	Marvin Briggs	Affirmative	
6	Cleco Power LLC	Robert Hirchak	Negative	SUPPORTS THIRD PARTY COMMENTS
6	Colorado Springs Utilities	Shannon Fair	Negative	
6	Con Edison Company of New York	David Balban	Affirmative	
6	Constellation Energy Commodities Group	David J Carlson	Affirmative	
6	Dominion Resources, Inc.	Louis S. Slade	Affirmative	
6	Duke Energy	Greg Cecil	Negative	SUPPORTS THIRD PARTY COMMENTS
6	FirstEnergy Solutions	Kevin Querry	Affirmative	
6	Florida Municipal Power Agency	Richard L. Montgomery	Affirmative	
6	Florida Municipal Power Pool	Thomas Washburn		
6	Florida Power & Light Co.	Silvia P Mitchell	Affirmative	
6	Great River Energy	Donna Stephenson		
6	Kansas City Power & Light Co.	Jessica L Klinghoffer	Negative	
6	Lakeland Electric	Paul Shipps		
6	Lincoln Electric System	Eric Ruskamp	Negative	SUPPORTS THIRD PARTY COMMENTS
6	Lower Colorado River Authority	Michael Shaw	Affirmative	
6	Luminant Energy	Brenda Hampton	Negative	SUPPORTS THIRD PARTY COMMENTS
6	Manitoba Hydro	Blair Mukanik	Affirmative	
6	Modesto Irrigation District	James McFall	Affirmative	
6	New York Power Authority	Shivaz Chopra	Affirmative	
6	Northern Indiana Public Service Co.	Joseph O'Brien	Abstain	
6	Oglethorpe Power Corporation	Donna Johnson	Affirmative	
6	Oklahoma Gas and Electric Co.	Jerry Nottnagel	Negative	
6	Omaha Public Power District	Douglas Collins	Negative	SUPPORTS THIRD PARTY COMMENTS
6	PacifiCorp	Sandra L Shaffer	Negative	
6	Platte River Power Authority	Carol Ballantine	Affirmative	
6	Portland General Electric Co.	Shawn P Davis		
6	Power Generation Services, Inc.	Stephen C Knapp		
6	Powerex Corp.	Gordon Dobson-Mack	Negative	SUPPORTS THIRD PARTY

				COMMENTS
6	PPL EnergyPlus LLC	Elizabeth Davis	Affirmative	
6	PSEG Energy Resources & Trade LLC	Peter Dolan	Negative	SUPPORTS THIRD PARTY COMMENTS
6	Public Utility District No. 1 of Chelan County	Hugh A. Owen	Abstain	
6	Sacramento Municipal Utility District	Diane Enderby	Affirmative	
6	Salt River Project	William Abraham	Affirmative	
6	Santee Cooper	Michael Brown	Abstain	
6	Seattle City Light	Dennis Sismaet	Negative	
6	Seminole Electric Cooperative, Inc.	Trudy S. Novak	Negative	
6	Snohomish County PUD No. 1	Kenn Backholm	Affirmative	
6	Southern California Edison Company	Joseph T Marone	Affirmative	
6	Southern Company Generation and Energy Marketing	John J. Ciza	Affirmative	
6	Tacoma Public Utilities	Michael C Hill	Affirmative	
6	Tampa Electric Co.	Benjamin F Smith II		
6	Tennessee Valley Authority	Marjorie S Parsons	Affirmative	
6	Westar Energy	Grant L Wilkerson	Affirmative	
6	Western Area Power Administration - UGP Marketing	Peter H Kinney		
6	Xcel Energy, Inc.	Peter Colussy	Negative	
7	Occidental Chemical	Venona Greaff	Negative	SUPPORTS THIRD PARTY COMMENTS
7	Siemens Energy, Inc.	Frank R. McElvain		
8		David L Kiguel	Affirmative	
8		Roger C Zaklukiewicz	Affirmative	
8	Massachusetts Attorney General	Frederick R Plett	Abstain	
8	Volkman Consulting, Inc.	Terry Volkman	Negative	SUPPORTS THIRD PARTY COMMENTS
9	Commonwealth of Massachusetts Department of Public Utilities	Donald Nelson	Affirmative	
9	New York State Public Service Commission	Diane J Barney	Affirmative	
10	Florida Reliability Coordinating Council	Linda C Campbell	Affirmative	
10	Midwest Reliability Organization	Russel Mountjoy	Affirmative	
10	New York State Reliability Council	Alan Adamson	Affirmative	
10	Northeast Power Coordinating Council	Guy V. Zito	Affirmative	
10	ReliabilityFirst	Anthony E Jablonski	Affirmative	
10	SERC Reliability Corporation	Joseph W Spencer	Affirmative	
10	Southwest Power Pool RE	Bob Reynolds		
10	Texas Reliability Entity, Inc.	Karin Schweitzer	Affirmative	
10	Western Electricity Coordinating Council	Steven L. Rueckert	Affirmative	

Legal and Privacy : 404.446.2560 voice : 404.467.0474 fax : 3353 Peachtree Road, N.E. : Suite 600, North Tower : Atlanta, GA 30326  
 Washington Office: 1325 G Street, N.W. : Suite 600 : Washington, DC 20005-3801

[Account Log-In/Register](#)

Copyright © 2014 by the North American Electric Reliability Corporation. : All rights reserved.  
 A New Jersey Nonprofit Corporation

**Exhibit H**

**Standard Drafting Team Roster**

## Team Roster

### Project 2010-13.3 Phase 3 of Relay Loadability: Stable Power Swings

	Participant	Contact Information
Chair	Bill Middaugh, P.E. System Protection Manager	Tri-State Generation & Transmission Association, Inc. 1100 W. 116th Avenue Westminster, Colorado 80234 (303) 254-3433 (303) 254-3566 Fx bmiddaugh@tristategt.org
Vice Chair	Kevin W. Jones, P.E. Principal Engineer, System Protection Engineering	Xcel Energy, Inc. 600 South Tyler Street Suite 2800 Amarillo, Texas 79101 (806) 378-2376 (806) 378-2883 Fx Kevin.Jones@xcelenergy.com
Member	David E. Barber, P.E. Supervisor Transmission Protection	FirstEnergy P.O. Box 16001 Reading, Pennsylvania 19612-6001 (610) 921-6542 debarber@firstenergycorp.com
Member	Steven Black, P.E. Project Planning Engineer	Florida Reliability Coordinating Council 3000 Bayport Drive Suite 600 Tampa, Florida 33607 (813) 289-5644 (813) 289-5646 Fx sblack@frcc.com

Member	Ding Lin, P.Eng. Principal System Protection Engineer	Manitoba Hydro PO Box 815 Winnipeg, Manitoba R3C 2P4 (204) 360-5416 dlin@hydro.mb.ca
Member	Slobodan Pajic Principal Engineer	GE Energy One River Road Bldg. 53, Room 302A Schenectady, New York 12345 (518) 385-3963 slobodan.pajic@ge.com
Member	Fabio Rodriguez, P.E. Principal Engineer	Duke Energy - Florida 6565 38th Avenue N. St. Petersburg, Florida 33710 (727) 384-7544 fabio.rodriguez@duke-energy.com
Member	John Schmall, P.E. Senior Planning Engineer	Electric Reliability Council of Texas, Inc. 2705 West Lake Drive Taylor, Texas 76574-4953 (512) 248-4243 john.schmall@ercot.com
Member	Matthew H. Tackett, P.E. Principal Advisor-Transmission Expansion Planning	MISO P.O. Box 4202 Carmel, Indiana 46082-4202 (317) 249-5455 mtackett@misoenergy.org
Observer	Gene Henneberg Staff Protection Engineer	NV Energy 1 Ohm Place P.O. Box 10100 Reno, Nevada 89511 (775) 834-7187 (775) 834-7199 Fx ghenneberg@nvenergy.com

Observer	David Youngblood	Luminant Energy 500 North Akard Street Dallas, Texas 75201 (903) 360-1202 dyoungb2@yahoo.com
NERC Staff	Scott Barfield-McGinnis, P.E. Standards Developer	North American Electric Reliability Corporation 3353 Peachtree Road, N.E. Suite 600, North Tower Atlanta, Georgia 30326 (404) 446-2560 (404) 446-2595 Fx scott.barfield@nerc.net
NERC Staff	William Edwards Counsel, Standards	North American Electric Reliability Corporation 1325 G Street, N.W. Suite 600 Washington, D.C. 20005 (202) 400-3000 (202) 644-8099 Fx william.edwards@nerc.net
NERC Staff	Al McMeekin, P.E. Standards Developer	North American Electric Reliability Corporation 3353 Peachtree Road, N.E. Suite 600, North Tower Atlanta, Georgia 30326 (404) 446-2560 (404) 446-2595 Fx al.mcmeekin@nerc.net