

Exhibit A-1

FAC-011-4 (Clean and Redline to Last Approved)

## A. Introduction

**Title:** System Operating Limits Methodology for the Operations Horizon

**Number:** FAC-011-4

**Purpose:** To ensure that System Operating Limits (SOLs) used in the reliable operation of the Bulk Electric System (BES) are determined based on an established methodology or methodologies.

**Applicability:**

**1.1. Functional Entities:**

**4.1.1. Reliability Coordinator**

**Effective Date:** See Implementation Plan for [Project 2015-09](#).

## B. Requirements and Measures

- R1.** Each Reliability Coordinator shall have a documented methodology for establishing SOLs (i.e., SOL methodology) within its Reliability Coordinator Area. *[Violation Risk Factor: Medium] [Time Horizon: Operations Planning]*
- M1.** Acceptable evidence may include, but is not limited to, dated electronic or hard copy documentation of its SOL methodology.
- R2.** Each Reliability Coordinator shall include in its SOL methodology the method for Transmission Operators to determine which owner-provided Facility Ratings are to be used in operations such that the Transmission Operator and its Reliability Coordinator use common Facility Ratings *[Violation Risk Factor: Medium] [Time Horizon: Operations Planning]*
- M2.** Acceptable evidence may include, but is not limited to, dated electronic or hard copy documentation of its SOL methodology, that addresses the items listed in Requirement R2.
- R3.** Each Reliability Coordinator shall include in its SOL methodology the method for Transmission Operators to determine the System Voltage Limits to be used in operations. The method shall: *[Violation Risk Factor: Medium] [Time Horizon: Operations Planning]*
  - 3.1.** Require that each BES bus/station have an associated System Voltage Limits, unless its SOL methodology specifically allows the exclusion of BES buses/stations from the requirement to have an associated System Voltage Limit;
  - 3.2.** Require that System Voltage Limits respect voltage-based Facility Ratings;

- 3.3. Require that System Voltage Limits are greater than or equal to in-service BES relay settings for undervoltage load shedding systems and Undervoltage Load Shedding Programs;
  - 3.4. Identify the minimum allowable System Voltage Limit;
  - 3.5. Define the method for determining common System Voltage Limits between the Reliability Coordinator and its Transmission Operators, between adjacent Transmission Operators, and between adjacent Reliability Coordinators within an Interconnection.
- M3.** Acceptable evidence may include, but is not limited to, dated electronic or hard copy documentation of its SOL methodology that addresses the items listed in Requirement R3.
- R4.** Each Reliability Coordinator shall include in its SOL methodology the method for determining the stability limits to be used in operations. The method shall: *[Violation Risk Factor: Medium] [Time Horizon: Operations Planning]*
- 4.1. Specify stability performance criteria, including any margins applied. The criteria shall, at a minimum, include the following:
    - 4.1.1. steady-state voltage stability;
    - 4.1.2. transient voltage response;
    - 4.1.3. angular stability; and
    - 4.1.4. System damping.
  - 4.2. Require that stability limits are established to meet the criteria specified in Part 4.1 for the Contingencies identified in Requirement R5 applicable to the establishment of stability limits that are expected to produce more severe System impacts on its portion of the BES.
  - 4.3. Describe how the Reliability Coordinator establishes stability limits when there is an impact to more than one Transmission Operator in its Reliability Coordinator Area or other Reliability Coordinator Areas.
  - 4.4. Describe how stability limits are determined, considering levels of transfers, Load and generation dispatch, and System conditions including any changes to System topology such as Facility outages.
  - 4.5. Describe the level of detail that is required for the study model(s), including the portion modeled of the Reliability Coordinator Area, and the critical modeling details from other Reliability Coordinator Areas, necessary to determine different types of stability limits.
  - 4.6. Describe the allowed uses of Remedial Action Schemes and other automatic post-Contingency mitigation actions in establishing stability limits used in operations.

- 4.7.** State that the use of underfrequency load shedding (UFLS) programs and Undervoltage Load Shedding (UVLS) Programs are not allowed in the establishment of stability limits.
- M4.** Acceptable evidence may include, but is not limited to, dated electronic or hard copy documentation of its SOL methodology that addresses the items listed in Requirement R4.
- R5.** Each Reliability Coordinator shall identify in its SOL methodology the set of Contingency events for use in determining stability limits and the set of Contingency events for use in performing Operational Planning Analysis (OPAs) and Real-time Assessments (RTAs). The SOL methodology for each set shall: *[Violation Risk Factor: Medium] [Time Horizon: Operations Planning]*
- 5.1.** Specify the following single Contingency events
- 5.1.1.** Loss of any of the following either by single phase to ground or three phase Fault (whichever is more severe) with Normal Clearing, or without a Fault:
- generator;
  - transmission circuit;
  - transformer;
  - shunt device; or
  - single pole block in a monopolar or bipolar high voltage direct current system.
- 5.2.** Specify additional single or multiple Contingency events or types of Contingency events, if any.
- 5.3.** Describe the method(s) for identifying which, if any, of the Contingency events provided by the Planning Coordinator or Transmission Planner in accordance with FAC-014-3, Requirement R7, to use in determining stability limits.
- M5.** Acceptable evidence may include, but is not limited to, dated electronic or hard copy documentation of its SOL methodology that addresses the items listed in Requirement R5.
- R6.** Each Reliability Coordinator shall include the following performance framework in its SOL methodology to determine SOL exceedances when performing Real-time monitoring, Real-time Assessments, and Operational Planning Analyses: *[Violation Risk Factor: High] [Time Horizon: Operations Planning]*
- 6.1.** System performance for no Contingencies demonstrates the following:
- 6.1.1.** Steady state flow through Facilities are within Normal Ratings; however, Emergency Ratings may be used when System adjustments to return the



flow within its Normal Rating could be executed and completed within the specified time duration of those Emergency Ratings.

- 6.1.2.** Steady state voltages are within normal System Voltage Limits; however, emergency System Voltage Limits may be used when System adjustments to return the voltage within its normal System Voltage Limits could be executed and completed within the specified time duration of those emergency System Voltage Limits.
- 6.1.3.** Predetermined stability limits are not exceeded.
- 6.1.4.** Instability, Cascading or uncontrolled separation that adversely impact the reliability of the Bulk Electric System does not occur.<sup>1</sup>
- 6.2.** System performance for the single Contingencies listed in Part 5.1 demonstrates the following:
  - 6.2.1.** Steady state post-Contingency flow through Facilities within applicable Emergency Ratings. Steady state post-Contingency flow through a Facility must not be above the Facility’s highest Emergency Rating.
  - 6.2.2.** Steady state post-Contingency voltages are within emergency System Voltage Limits.
  - 6.2.3.** The stability performance criteria defined in the Reliability Coordinator’s SOL methodology are met<sup>1</sup>.
  - 6.2.4.** Instability, Cascading or uncontrolled separation that adversely impact the reliability of the Bulk Electric System does not occur<sup>1</sup>.
- 6.3.** System performance for applicable Contingencies identified in Part 5.2 demonstrates that: instability, Cascading, or uncontrolled separation that adversely impact the reliability of the Bulk Electric System does not occur.
- 6.4.** In determining the System’s response to any Contingency identified in Requirement R5, planned manual load shedding is acceptable only after all other available System adjustments have been made.
- M6.** Acceptable evidence may include, but is not limited to, dated electronic or hard copy documentation of its SOL methodology that addresses the items listed in Requirement R6.
- R7.** Each Reliability Coordinator shall include in its SOL methodology a risk-based approach for determining how SOL exceedances identified as part of Real-time monitoring and Real-time Assessments must be communicated and if so, the timeframe that communication must occur. The approach shall include: *[Violation Risk Factor: High] [Time Horizon: Operations Planning]*

---

<sup>1</sup> Stability evaluations and assessments of instability, Cascading, and uncontrolled separation can be performed using real-time stability assessments, predetermined stability limits or other offline analysis techniques.

- 7.1.** A requirement that the following SOL exceedances will always be communicated, within a timeframe identified by the Reliability Coordinator.
  - 7.1.1** IROL exceedances;
  - 7.1.2** SOL exceedances of stability limits;
  - 7.1.3** Post Contingency SOL exceedances that are identified to have a validated risk of instability, Cascading, and uncontrolled separation;
  - 7.1.4** Pre-Contingency SOL exceedances of Facility Ratings; and
  - 7.1.5** Pre-Contingency SOL exceedances of normal minimum System Voltage Limits.
- 7.2.** A requirement that the following SOL exceedances must be communicated, if not resolved within 30 minutes, within a timeframe identified by the Reliability Coordinator.
  - 7.2.1** Post-Contingency SOL exceedances of Facility Ratings and emergency System Voltage Limits, and
  - 7.2.2** Pre-Contingency SOL exceedances of normal maximum System Voltage Limits.
- M7.** Acceptable evidence may include, but is not limited to dated electronic or hard copy documentation of its SOL methodology that addresses the items listed in Requirement R7.
- R8.** Each Reliability Coordinator shall include in its SOL methodology: *[Violation Risk Factor: High] [Time Horizon: Operations Planning]*
  - 8.1.** A description of how to identify the subset of SOLs that qualify as Interconnection Reliability Operating Limits (IROLs).
  - 8.2.** Criteria for determining when exceeding a SOL qualifies as exceeding an IROL and criteria for developing any associated IROL  $T_v$ .
- M8.** Acceptable evidence may include, but is not limited to, dated electronic or hard copy documentation of its SOL methodology that addresses the items listed in Requirement R8.
- R9.** Each Reliability Coordinator shall provide its SOL methodology to: *[Violation Risk Factor: Lower] [Time Horizon: Operations Planning]*
  - 9.1.** Each Reliability Coordinator that requests and indicates it has a reliability-related need within 30 days of a request.
  - 9.2.** Each of the following entities prior to the effective date of the SOL methodology:
    - 9.2.1.** Each adjacent Reliability Coordinator within the same; Interconnection;
    - 9.2.2.** Each Planning Coordinator and Transmission Planner that is responsible for planning any portion of the Reliability Coordinator Area;

9.2.3. Each Transmission Operator within its Reliability Coordinator Area; and

9.2.4. Each Reliability Coordinator that has requested to receive updates and indicated it had a reliability-related need.

M9. Acceptable evidence may include, but is not limited to, dated electronic or hard copy documentation such as emails with receipts, registered mail receipts, or postings to a secure web site with accompanying notification(s).

## C. Compliance

### 1. Compliance Monitoring Process

1.1. **Compliance Enforcement Authority:** “Compliance Enforcement Authority” means NERC or the Regional Entity, or any entity as otherwise designated by an Applicable Governmental Authority, in their respective roles of monitoring and/or enforcing compliance with mandatory and enforceable Reliability Standards in their respective jurisdictions.

1.2. **Evidence Retention:** The following evidence retention period(s) identify the period of time an entity is required to retain specific evidence to demonstrate compliance. For instances where the evidence retention period specified below is shorter than the time since the last audit, the Compliance Enforcement Authority may ask an entity to provide other evidence to show that it was compliant for the full-time period since the last audit.

The applicable entity shall keep data or evidence to show compliance as identified below unless directed by its Compliance Enforcement Authority to retain specific evidence for a longer period of time as part of an investigation.

- The Reliability Coordinator shall keep data or evidence of compliance with Requirements R1 through R9 for the current year plus the previous 12 calendar months.

1.3. **Compliance Monitoring and Enforcement Program:** As defined in the NERC Rules of Procedure, “Compliance Monitoring and Enforcement Program” refers to the identification of the processes that will be used to evaluate data or information for the purpose of assessing performance or outcomes with the associated Reliability Standard.

## Violation Severity Levels

Requirement	Lower	Moderate	High	Severe
<b>R1.</b>	N/A	N/A	N/A	The Reliability Coordinator did not have a documented SOL methodology for establishing SOLs within its Reliability Coordinator Area.
<b>R2.</b>	N/A	N/A	The Reliability Coordinator included in its SOL methodology the method for Transmission Operators to determine which owner-provided Facility Ratings are to be used in operations, but the method did not address the use of common Facility Ratings between the Reliability Coordinator and the Transmission Operators in its Reliability Coordinator Area.	The Reliability Coordinator did not include in its SOL methodology the method for Transmission Operators to determine which owner-provided Facility Ratings are to be used in operations.
<b>R3.</b>	The Reliability Coordinator failed to incorporate one of the Parts of Requirement R3 into its SOL methodology.	The Reliability Coordinator failed to incorporate two of the Parts of Requirement R3 into its SOL methodology.	The Reliability Coordinator failed to incorporate three of the Parts of Requirement R3 into its SOL methodology.	The Reliability Coordinator failed to incorporate four or more of the Parts of Requirement R3 into its SOL methodology.
<b>R4.</b>	The Reliability Coordinator failed to incorporate one of	The Reliability Coordinator failed to incorporate two of	The Reliability Coordinator failed to incorporate three of	The Reliability Coordinator failed to incorporate four or

Requirement	Lower	Moderate	High	Severe
	the Parts of Requirement R4 into its SOL methodology.	the Parts of Requirement R4 into its SOL methodology.	the Parts of Requirement R4 into its SOL methodology.	more of the Parts of Requirement R4 into its SOL methodology.
<b>R5.</b>	N/A	N/A	The Reliability Coordinator failed to incorporate one of the Parts 5.2 or 5.3 of Requirement R5 into its SOL methodology.	The Reliability Coordinator failed to incorporate Part 5.1 of Requirement R5 into its SOL methodology.  OR The Reliability Coordinator failed to incorporate Parts 5.2 and 5.3 of Requirement R5 into its SOL methodology.
<b>R6.</b>	The Reliability Coordinator failed to incorporate one of the Parts of Requirement R6 into its SOL methodology.	The Reliability Coordinator failed to incorporate two of the Parts of Requirement R6 into its SOL methodology.	The Reliability Coordinator failed to incorporate three of the Parts of Requirement R6 into its SOL methodology.	The Reliability Coordinator failed to incorporate four of the Parts of Requirement R6 into its SOL methodology.
<b>R7.</b>	N/A	The Reliability Coordinator included in its SOL methodology, a risk-based approach for determining how SOL exceedances identified as part of Real-time monitoring and Real-time Assessments must be communicated and if so, with what priority, but failed to	The Reliability Coordinator included in its SOL methodology, a risk-based approach for determining how SOL exceedances identified as part of Real-time monitoring and Real-time Assessments must be communicated and if so, with what priority, but failed to	The Reliability Coordinator failed to include in its SOL methodology, a risk-based approach for determining how SOL exceedances identified as part of Real-time monitoring and Real-time Assessments must be

Requirement	Lower	Moderate	High	Severe
		include one of the Parts 7.2.1 through 7.2.2.	include one of the Parts 7.1.1 through 7.1.5.	communicated and if so, with what priority.
<b>R8.</b>	N/A	N/A	<p>The Reliability Coordinator failed to include Part 8.1 (a description of how to identify the subset of SOLs that qualify as IROLs) in its SOL methodology.</p> <p>OR</p> <p>The Reliability Coordinator failed to include Part 8.2 (a criteria for determining when violating a SOL qualifies as an IROL in its SOL methodology.</p> <p>OR</p> <p>The Reliability Coordinator failed to include Part 8.2 (criteria for developing any associated IROL <math>T_v</math>) in its SOL methodology.</p>	The Reliability Coordinator failed to include Parts 8.1 and 8.2 in its SOL methodology.
<b>R9.</b>	The Reliability Coordinator failed to provide its new or revised SOL methodology to one of the parties specified in	The Reliability Coordinator failed to provide its new or revised SOL methodology to two of the parties specified	The Reliability Coordinator failed to provide its new or revised SOL methodology to three of the parties specified	The Reliability Coordinator failed to provide its new or revised SOL methodology to four or more of the parties specified in Requirement R9,

Requirement	Lower	Moderate	High	Severe
	<p>Requirement R9, Part 9.2 prior to the effective date</p> <p>OR</p> <p>The Reliability Coordinator provided its new or revised SOL methodology to a requesting Reliability Coordinator in accordance with Requirement R9, Part 9.1 but was late by less than or equal to 10 calendar days.</p>	<p>in Requirement R9, Part 9.2 prior to the effective date</p> <p>OR</p> <p>The Reliability Coordinator provided its new or revised SOL methodology to a requesting Reliability Coordinator in accordance with Requirement R9, Part 9.1, but was late by more than 10 calendar days but less than or equal to 20 calendar days.</p>	<p>in Requirement R9, Part 9.2 prior to the effective date</p> <p>OR</p> <p>The Reliability Coordinator provided its new or revised SOL methodology to a requesting Reliability Coordinator in accordance with Requirement R9, Part 9.1, but was late by more than 20 calendar days but less than or equal to 30 calendar days.</p>	<p>Part 9.2 prior to the effective date</p> <p>OR</p> <p>The Reliability Coordinator failed to provide its new or revised SOL methodology to one or more of the parties specified in Requirement R9, Part 9.2</p> <p>OR</p> <p>The Reliability Coordinator provided its new or revised SOL methodology to a requesting Reliability Coordinator in accordance with Requirement R9, Part 9.1, but was late by more than 30 calendar days.</p> <p>OR</p> <p>The Reliability Coordinator failed to provide its new or revised SOL methodology to a requesting Reliability Coordinator in accordance with Requirement R9, Part 9.1.</p>

## **D. Regional Variances**

None.

## **E. Associated Documents**

Implementation Plan



## Version History

Version	Date	Action	Change Tracking
1	November 1, 2006	Adopted by Board	New
2		<p>Changed the effective date to October 1, 2008</p> <p>Changed “Cascading Outage” to “Cascading”</p> <p>Replaced Levels of Non-compliance with Violation Severity Levels</p> <p>Corrected footnote 1 to reference FAC-011 rather than FAC-010</p>	Revised
2	June 24, 2008	Adopted by Board: FERC Order 705	Revised
2	January 22, 2010	Updated effective date and footer to April 29, 2009 based on the March 20, 2009 FERC Order	Update
2	February 7, 2013	R5 and associated elements approved by NERC Board of Trustees for retirement as part of the Paragraph 81 project (Project 2013-02) pending applicable regulatory approval.	
2	November 21, 2013	R5 and associated elements approved by FERC for retirement as part of the Paragraph 81 project (Project 2013-02)	
2	February 24, 2014	Updated VSLs based on June 24, 2013 approval.	
3	November 13, 2014	Adopted by the NERC Board	Replaced references to Special Protection System and SPS with Remedial Action Scheme and RAS
3	November 19, 2015	FERC Order issued approving FAC-011-3. Docket No. RM15-13-000.	

**FAC-011-4– System Operating Limits Methodology for the Operations Horizon**

---

4	May 13, 2021	Adopted by the NERC Board of Trustees	Revised under Project 2015-09
---	--------------	---------------------------------------	-------------------------------

## A. Introduction

**Title:** System Operating Limits Methodology for the Operations Horizon

**Number:** FAC-011-~~43~~

**Purpose:** To ensure that System Operating Limits (SOLs) used in the reliable operation of the Bulk Electric System (BES) are determined based on an established methodology or methodologies.

**Applicability:**

### 1.1. Functional Entities:

#### 4.1.1. Reliability Coordinator

**Effective Date:** See Implementation Plan for [Project 2015-09](#).

## B. Requirements and Measures

- R1.** ~~The Each~~ Reliability Coordinator shall have a documented methodology for ~~use in establishing developing~~ SOLs (i.e., SOL ~~M~~ methodology) within its Reliability Coordinator Area. ~~This SOL Methodology shall:~~ *[Violation Risk Factor: Medium] [Time Horizon: Operations Planning]*
- ~~1.0.~~ — Be applicable for developing SOLs used in the operations horizon.
  - ~~2.0.~~ — State that SOLs shall not exceed associated Facility Ratings.
  - ~~3.0.~~ — Include a description of how to identify the subset of SOLs that qualify as IROLs.
- M1.** ~~Acceptable evidence may include, but is not limited to, dated electronic or hard copy documentation of its~~ The Reliability Coordinator's SOL ~~M~~ methodology shall address all of the items listed in Requirement 1 through Requirement 3.
- R2.** ~~The Each~~ Reliability Coordinator ~~'s~~ shall include in its SOL ~~M~~ methodology the method for Transmission Operators to determine which owner-provided Facility Ratings are to be used in operations such that the Transmission Operator and its Reliability Coordinator use common Facility Ratings shall include a requirement that SOLs provide BES performance consistent with the following: *[Violation Risk Factor: Medium] [Time Horizon: Operations Planning]*
- ~~4.0.~~ — In the pre-contingency state, the BES shall demonstrate transient, dynamic and voltage stability; all Facilities shall be within their Facility Ratings and within their thermal, voltage and stability limits. In the determination of SOLs, the BES condition used shall reflect current or expected system conditions and shall reflect changes to system topology such as Facility outages.

- ~~2.1.~~ Following the single Contingencies<sup>†</sup> identified in Requirement 2.2.1 through Requirement 2.2.3, the system shall demonstrate transient, dynamic and voltage stability; all Facilities shall be operating within their Facility Ratings and within their thermal, voltage and stability limits; and Cascading or uncontrolled separation shall not occur.
- ~~0.~~ Single line to ground or 3 phase Fault (whichever is more severe), with Normal Clearing, on any Faulted generator, line, transformer, or shunt device.
  - ~~0.~~ Loss of any generator, line, transformer, or shunt device without a Fault.
  - ~~0.~~ Single pole block, with Normal Clearing, in a monopolar or bipolar high voltage direct current system.
- ~~8.0.~~ In determining the system's response to a single Contingency, the following shall be acceptable:
- ~~0.~~ Planned or controlled interruption of electric supply to radial customers or some local network customers connected to or supplied by the Faulted Facility or by the affected area.
  - ~~0.~~ Interruption of other network customers, (a) only if the system has already been adjusted, or is being adjusted, following at least one prior outage, or (b) if the real time operating conditions are more adverse than anticipated in the corresponding studies
  - ~~0.~~ System reconfiguration through manual or automatic control or protection actions.
- ~~12.0.~~ To prepare for the next Contingency, system adjustments may be made, including changes to generation, uses of the transmission system, and the transmission system topology.

M2. Acceptable evidence may include, but is not limited to, dated electronic or hard copy documentation of its The Reliability Coordinator shall have evidence it issued its SOL Methodology, that addresses the items listed in Requirement R2 and any changes to that methodology, including the date they were issued, in accordance with Requirement 4.

R4.R3. The Each Reliability Coordinator's shall include in its SOL methodology method the methodology for Transmission Operators to determining the System Voltage Limits to be used in operations. The method shall: SOLs, shall include, as a minimum, a description of the following, along with any reliability

---

<sup>†</sup>The Contingencies identified in FAC 011 R2.2.1 through R2.2.3 are the minimum contingencies that must be studied but are not necessarily the only Contingencies that should be studied.

~~margins applied for each: [Violation Risk Factor: Medium] [Time Horizon: Operations Planning]~~

~~4.1.3.1. Require that each BES bus/station have an associated System Voltage Limits, unless its SOL methodology specifically allows the exclusion of BES buses/stations from the requirement to have an associated System Voltage Limit; Study model (must include at least the entire Reliability Coordinator Area as well as the critical modeling details from other Reliability Coordinator Areas that would impact the Facility or Facilities under study.)~~

~~4.2.3.2. Require that System Voltage Limits respect voltage-based Facility Ratings; Selection of applicable Contingencies~~

~~4.3.3.3. Require that System Voltage Limits are greater than or equal to in-service BES relay settings for undervoltage load shedding systems and Undervoltage Load Shedding Programs; A process for determining which of the stability limits associated with the list of multiple contingencies (provided by the Planning Authority in accordance with FAC-014 Requirement 6) are applicable for use in the operating horizon given the actual or expected system conditions.~~

~~0. This process shall address the need to modify these limits, to modify the list of limits, and to modify the list of associated multiple contingencies.~~

~~4.5.3.4. Identify the minimum allowable System Voltage Limit; Level of detail of system models used to determine SOLs.~~

~~4.6.3.5. Define the method for determining common System Voltage Limits between the Reliability Coordinator and its Transmission Operators, between adjacent Transmission Operators, and between adjacent Reliability Coordinators within an Interconnection Allowed uses of Remedial Action Schemes.~~

~~13.0. Anticipated transmission system configuration, generation dispatch and Load level~~

~~14.0. Criteria for determining when violating a SOL qualifies as an Interconnection Reliability Operating Limit (IROL) and criteria for developing any associated IROL T<sub>v</sub>.~~

~~M3. Acceptable evidence may include, but is not limited to, dated electronic or hard copy documentation of its SOL methodology that addresses the items listed in Requirement R3.~~

~~R5-R4. The Each Reliability Coordinator shall include in issue its SOL methodology the method for determining the stability limits to be used in operations. The method shall: [Violation Risk Factor: Medium] [Time Horizon: Operations Planning] and any changes to that methodology, prior to the effectiveness of the Methodology or of a change to the Methodology, to all of the following:~~

- 4.1. Specify stability performance criteria, including any margins applied. The criteria shall, at a minimum, include the following: ~~Each adjacent Reliability Coordinator and each Reliability Coordinator that indicated it has a reliability-related need for the methodology.~~
- 4.1.1. steady-state voltage stability;
  - 4.1.2. transient voltage response;
  - 4.1.3. angular stability; and
  - 4.1.4. System damping.
- 5.1.4.2. ~~Require that stability limits are established to meet the criteria specified in Part 4.1 for the Contingencies identified in Requirement R5 applicable to the establishment of stability limits that are expected to produce more severe System impacts on its~~ Each Planning Authority and Transmission Planner that models any portion of the Reliability Coordinator's Reliability Coordinator Area the BES.
- 4.3. Describe how the Reliability Coordinator establishes stability limits when ~~there is an impact to more than one~~ Each Transmission Operator in its Reliability Coordinator Area or other that operates in the Reliability Coordinator Areas.
- 4.4. Describe how stability limits are determined, considering levels of transfers, Load and generation dispatch, and System conditions including any changes to System topology such as Facility outages.
- 4.5. Describe the level of detail that is required for the study model(s), including ~~the portion modeled of the Reliability Coordinator Area, and the critical modeling details from other Reliability Coordinator Areas, necessary to determine different types of stability limits.~~
- 4.6. Describe the allowed uses of Remedial Action Schemes and other automatic post-Contingency mitigation actions in establishing stability limits used in operations.
- 4.7. State that the use of underfrequency load shedding (UFLS) programs and Undervoltage Load Shedding (UVLS) Programs are not allowed in the establishment of stability limits.
- M4. Acceptable evidence may include, but is not limited to, dated electronic or hard copy documentation of its SOL methodology that addresses the items listed in Requirement R4.
- R5. Each Reliability Coordinator shall identify in its SOL methodology the set of Contingency events for use in determining stability limits and the set of Contingency events for use in performing Operational Planning Analysis (OPAs) and Real-time Assessments (RTAs). The SOL methodology for each set shall: [Violation Risk Factor: Medium] [Time Horizon: Operations Planning]

5.1. Specify the following single Contingency events

5.1.1. Loss of any of the following either by single phase to ground or three phase Fault (whichever is more severe) with Normal Clearing, or without a Fault:

- generator;
- transmission circuit;
- transformer;
- shunt device; or
- single pole block in a monopolar or bipolar high voltage direct current system.

5.2. Specify additional single or multiple Contingency events or types of Contingency events, if any.

5.3. Describe the method(s) for identifying which, if any, of the Contingency events provided by the Planning Coordinator or Transmission Planner in accordance with FAC-014-3, Requirement R7, to use in determining stability limits.

M5. Acceptable evidence may include, but is not limited to, dated electronic or hard copy documentation of its SOL methodology that addresses the items listed in Requirement R5.

R6. Each Reliability Coordinator shall include the following performance framework in its SOL methodology to determine SOL exceedances when performing Real-time monitoring, Real-time Assessments, and Operational Planning Analyses: *[Violation Risk Factor: High] [Time Horizon: Operations Planning]*

6.1. System performance for no Contingencies demonstrates the following:

6.1.1. Steady state flow through Facilities are within Normal Ratings; however, Emergency Ratings may be used when System adjustments to return the flow within its Normal Rating could be executed and completed within the specified time duration of those Emergency Ratings.

6.1.2. Steady state voltages are within normal System Voltage Limits; however, emergency System Voltage Limits may be used when System adjustments to return the voltage within its normal System Voltage Limits could be executed and completed within the specified time duration of those emergency System Voltage Limits.

6.1.3. Predetermined stability limits are not exceeded.

- 6.1.4. Instability, Cascading or uncontrolled separation that adversely impact the reliability of the Bulk Electric System does not occur.<sup>1</sup>
- 6.2. System performance for the single Contingencies listed in Part 5.1 demonstrates the following:
  - 6.2.1. Steady state post-Contingency flow through Facilities within applicable -Emergency Ratings. Steady state post-Contingency flow through a Facility -must not be above the Facility’s highest Emergency Rating.
  - 6.2.2. Steady state post-Contingency voltages are within emergency System -Voltage Limits.
  - 6.2.3. The stability performance criteria defined in the Reliability Coordinator’s -SOL methodology are met<sup>1</sup>.
  - 6.2.4. Instability, Cascading or uncontrolled separation that adversely impact -the reliability of the Bulk Electric System does not occur<sup>1</sup>.
- 6.3. System performance for applicable Contingencies identified in Part 5.2 demonstrates that: instability, Cascading, or uncontrolled separation that adversely impact the reliability of the Bulk Electric System does not occur.
- 6.4. In determining the System’s response to any Contingency identified in Requirement R5, planned manual load shedding is acceptable only after all other available System adjustments have been made.
- M6. Acceptable evidence may include, but is not limited to, dated electronic or hard copy documentation of its SOL methodology that addresses the items listed in Requirement R6.
- R7. Each Reliability Coordinator shall include in its SOL methodology a risk-based approach for determining how SOL exceedances identified as part of Real-time monitoring and Real-time Assessments must be communicated and if so, the timeframe that communication must occur. The approach shall include: *[Violation Risk Factor: High] [Time Horizon: Operations Planning]*
- 7.1. A requirement that the following SOL exceedances will always be communicated, within a timeframe identified by the Reliability Coordinator.
  - 7.1.1 IROL exceedances;
  - 7.1.2 SOL exceedances of stability limits;
  - 7.1.3 Post Contingency SOL exceedances that are identified to have a validated risk of instability, Cascading, and uncontrolled separation;
  - 7.1.4 Pre-Contingency SOL exceedances of Facility Ratings; and

---

<sup>1</sup> Stability evaluations and assessments of instability, Cascading, and uncontrolled separation can be performed using real-time stability assessments, predetermined stability limits or other offline analysis techniques.



7.1.5 Pre-Contingency SOL exceedances of normal minimum System Voltage Limits.

7.2. A requirement that the following SOL exceedances must be communicated, if not resolved within 30 minutes, within a timeframe identified by the Reliability Coordinator.

7.2.1 Post-Contingency SOL exceedances of Facility Ratings and emergency System Voltage Limits, and

7.2.2 Pre-Contingency SOL exceedances of normal maximum System Voltage Limits.

M7. Acceptable evidence may include, but is not limited to dated electronic or hard copy documentation of its SOL methodology that addresses the items listed in Requirement R7.

R8. Each Reliability Coordinator shall include in its SOL methodology: *[Violation Risk Factor: High] [Time Horizon: Operations Planning]*

8.1. A description of how to identify the subset of SOLs that qualify as Interconnection Reliability Operating Limits (IROLs).

8.2. Criteria for determining when exceeding a SOL qualifies as exceeding an IROL and criteria for developing any associated IROL  $T_v$ .

M8. Acceptable evidence may include, but is not limited to, dated electronic or hard copy documentation of its SOL methodology that addresses the items listed in Requirement R8.

R9. Each Reliability Coordinator shall provide its SOL methodology to: *[Violation Risk Factor: Lower] [Time Horizon: Operations Planning]*

9.1. Each Reliability Coordinator that requests and indicates it has a reliability-related need within 30 days of a request.

9.2. Each of the following entities prior to the effective date of the SOL methodology:

9.2.1. Each adjacent Reliability Coordinator within the same; Interconnection;

9.2.2. Each Planning Coordinator and Transmission Planner that is responsible for planning any portion of the Reliability Coordinator Area;

9.2.3. Each Transmission Operator within its Reliability Coordinator Area; and

9.2.4. Each Reliability Coordinator that has requested to receive updates and -indicated it had a reliability-related need.

M9. Acceptable evidence may include, but is not limited to, dated electronic or hard copy documentation such as emails with receipts, registered mail receipts, or postings to a secure web site with accompanying notification(s).

~~M15.~~

~~M16-M1. The Reliability Coordinator's SOL Methodology shall address all of the items listed in Requirement 1 through Requirement 3.~~

~~M17-M1. The Reliability Coordinator shall have evidence it issued its SOL Methodology, and any changes to that methodology, including the date they were issued, in accordance with Requirement 4.~~

## C. Compliance

### 1. Compliance Monitoring Process

**1.1. Compliance Enforcement Authority:** "Compliance Enforcement Authority" means NERC or the Regional Entity, or any entity as otherwise designated by an Applicable Governmental Authority, in their respective roles of monitoring and/or enforcing compliance with mandatory and enforceable Reliability Standards in their respective jurisdictions.

**1.2. Evidence Retention:** The following evidence retention period(s) identify the period of time an entity is required to retain specific evidence to demonstrate compliance. For instances where the evidence retention period specified below is shorter than the time since the last audit, the Compliance Enforcement Authority may ask an entity to provide other evidence to show that it was compliant for the full-time period since the last audit.

The applicable entity shall keep data or evidence to show compliance as identified below unless directed by its Compliance Enforcement Authority to retain specific evidence for a longer period of time as part of an investigation.

- The Reliability Coordinator shall keep data or evidence of compliance with Requirements R1 through R9 for the current year plus the previous 12 calendar months.

**1.3. Compliance Monitoring and Enforcement Program:** As defined in the NERC Rules of Procedure, "Compliance Monitoring and Enforcement Program" refers to the identification of the processes that will be used to evaluate data or information for the purpose of assessing performance or outcomes with the associated Reliability Standard.

## Violation Severity Levels

Requirement	Lower	Moderate	High	Severe
<b>R1.</b>	<del>N/A Not applicable.</del>	<del>N/A The Reliability Coordinator has a documented SOL Methodology for use in developing SOLs within its Reliability Coordinator Area, but it does not address R1.2.</del>	<del>N/A The Reliability Coordinator has a documented SOL Methodology for use in developing SOLs within its Reliability Coordinator Area, but it does not address R1.3.</del>	<p>The Reliability Coordinator <del>has a documented</del> <u>did not have a documented</u> SOL <del>Methodology for use in developing</del> <u>establishing</u> SOLs within its Reliability Coordinator Area, <del>but it does not address R1.1.</del></p> <p>OR</p> <p>The Reliability Coordinator <del>has no documented SOL Methodology for use in developing SOLs within its Reliability Coordinator Area.</del></p>
<b>R2.</b>	<del>N/A The Reliability Coordinator's SOL Methodology requires that SOLs are set to meet BES performance following single contingencies, but does not require that SOLs are set to meet BES performance in the pre-contingency state. (R2.1)</del>	<del>N/A Not applicable.</del>	<del>The Reliability Coordinator's</del> <u>Coordinator</u> <del>included in its SOL</del> <u>Methodology</u> <del>the method for Transmission Operators to determine which owner-provided Facility Ratings are to be used in operations, but the method did not address the use of common Facility Ratings between the Reliability Coordinator and the Transmission Operators</del>	<del>The Reliability Coordinator's</del> <u>did not include in its</u> SOL <del>Methodology</del> <u>the method for Transmission Operators to determine which owner-provided Facility Ratings are to be used in operations.</u> <del>does not require that SOLs are set to meet BES performance in the pre-contingency state and does not require that SOLs are set to meet BES performance following single</del>

Requirement	Lower	Moderate	High	Severe
			<p><del>in its Reliability Coordinator Area, requires that SOLs are set to meet BES performance in the pre-contingency state, but does not require that SOLs are set to meet BES performance following single contingencies. (R2.2 — R2.4)</del></p>	<p><del>contingencies. (R2.1 through R2.4)</del></p>
<p><del>R3.</del></p>	<p><del>The Reliability Coordinator's failed to incorporate one of the Parts of Requirement R3 into its SOL Methodology includes a description for all but one of the following: R3.1 through R3.7.</del></p>	<p><del>The Reliability Coordinator's failed to incorporate two of the Parts of Requirement R3 into its SOL Methodology includes a description for all but two of the following: R3.1 through R3.7.</del></p>	<p><del>The Reliability Coordinator's failed to incorporate three of the Parts of Requirement R3 into its SOL Methodology includes a description for all but three of the following: R3.1 through R3.7.</del></p>	<p><del>The Reliability Coordinator's failed to incorporate four or more of the Parts of Requirement R3 into its SOL Methodology is missing a description of four or more of the following: R3.1 through R3.7.</del></p>
<p><del>R4.</del></p>	<p><del>The Reliability Coordinator failed to incorporate one of the Parts of Requirement R4 into its SOL Methodology and/or one or more changes to that methodology to one of the required entities specified in R4.1, R4.2, and R4.3.</del></p> <p><del>OR</del></p>	<p><del>The Reliability Coordinator failed to incorporate two of the Parts of Requirement R4 into its SOL Methodology and/or one or more changes to that methodology to two of the required entities specified in R4.1, R4.2, and R4.3.</del></p> <p><del>OR</del></p>	<p><del>The Reliability Coordinator failed to incorporate three of the Parts of Requirement R4 into its SOL Methodology and/or one or more changes to that methodology to three of the required entities specified in R4.1, R4.2, and R4.3.</del></p> <p><del>OR</del></p>	<p><del>The Reliability Coordinator failed to incorporate four or more of the Parts of Requirement R4 into its SOL Methodology and/or one or more changes to that methodology to four or more of the required entities specified in R4.1, R4.2, and R4.3.</del></p> <p><del>OR</del></p>

Requirement	Lower	Moderate	High	Severe
	<p><del>For a change in methodology, the changed methodology was provided to one or more of the required entities before the effectiveness of the change, but was provided to all the required entities no more than 10 calendar days after the effectiveness of the change.</del></p>	<p><del>For a change in methodology, the changed methodology was provided to one or more of the required entities more than 10 calendar days after the effectiveness of the change, but less than or equal to 20 days after the effectiveness of the change.</del></p>	<p><del>For a change in methodology, the changed methodology was provided to one or more of required entities more than 20 calendar days after the effectiveness of the change, but less than or equal to 30 days after the effectiveness of the change.</del></p>	<p><del>For a change in methodology, the changed methodology was provided to one or more of the required entities more than 30 calendar days after the effectiveness of the change.</del></p>
<u>R5.</u>	<u>N/A</u>	<u>N/A</u>	<p><u>The Reliability Coordinator failed to incorporate one of the Parts 5.2 or 5.3 of Requirement R5 into its SOL methodology.</u></p>	<p><u>The Reliability Coordinator failed to incorporate Part 5.1 of Requirement R5 into its SOL methodology.</u></p> <p><u>OR</u></p> <p><u>The Reliability Coordinator failed to incorporate Parts 5.2 and 5.3 of Requirement R5 into its SOL methodology.</u></p>
<u>R6.</u>	<p><u>The Reliability Coordinator failed to incorporate one of the Parts of Requirement R6 into its SOL methodology.</u></p>	<p><u>The Reliability Coordinator failed to incorporate two of the Parts of Requirement R6 into its SOL methodology.</u></p>	<p><u>The Reliability Coordinator failed to incorporate three of the Parts of Requirement R6 into its SOL methodology.</u></p>	<p><u>The Reliability Coordinator failed to incorporate four of the Parts of Requirement R6 into its SOL methodology.</u></p>
<u>R7.</u>	<u>N/A</u>	<p><u>The Reliability Coordinator included in its SOL methodology, a risk-based approach for determining</u></p>	<p><u>The Reliability Coordinator included in its SOL methodology, a risk-based approach for determining</u></p>	<p><u>The Reliability Coordinator failed to include in its SOL methodology, a risk-based approach for determining</u></p>

Requirement	Lower	Moderate	High	Severe
		<p><u>how SOL exceedances identified as part of Real-time monitoring and Real-time Assessments must be communicated and if so, with what priority, but failed to include one of the Parts 7.2.1 through 7.2.2.</u></p>	<p><u>how SOL exceedances identified as part of Real-time monitoring and Real-time Assessments must be communicated and if so, with what priority, but failed to include one of the Parts 7.1.1 through 7.1.5.</u></p>	<p><u>how SOL exceedances identified as part of Real-time monitoring and Real-time Assessments must be communicated and if so, with what priority.</u></p>
<p><u>R8.</u></p>	<p><u>N/A</u></p>	<p><u>N/A</u></p>	<p><u>The Reliability Coordinator failed to include Part 8.1 (a description of how to identify the subset of SOLs that qualify as IROLs) in its SOL methodology.</u></p> <p><u>OR</u></p> <p><u>The Reliability Coordinator failed to include Part 8.2 (a criteria for determining when violating a SOL qualifies as an IROL in its SOL methodology.</u></p> <p><u>OR</u></p> <p><u>The Reliability Coordinator failed to include Part 8.2 (criteria for developing any associated IROL T<sub>v</sub>) in its SOL methodology.</u></p>	<p><u>The Reliability Coordinator failed to include Parts 8.1 and 8.2 in its SOL methodology.</u></p>

Requirement	Lower	Moderate	High	Severe
<p><u>R9.</u></p>	<p><u>The Reliability Coordinator failed to provide its new or revised SOL methodology to one of the parties specified in Requirement R9, Part 9.2 prior to the effective date</u></p> <p><u>OR</u></p> <p><u>The Reliability Coordinator provided its new or revised SOL methodology to a requesting Reliability Coordinator in accordance with Requirement R9, Part 9.1 but was late by less than or equal to 10 calendar days.</u></p>	<p><u>The Reliability Coordinator failed to provide its new or revised SOL methodology to two of the parties specified in Requirement R9, Part 9.2 prior to the effective date</u></p> <p><u>OR</u></p> <p><u>The Reliability Coordinator provided its new or revised SOL methodology to a requesting Reliability Coordinator in accordance with Requirement R9, Part 9.1, but was late by more than 10 calendar days but less than or equal to 20 calendar days.</u></p>	<p><u>The Reliability Coordinator failed to provide its new or revised SOL methodology to three of the parties specified in Requirement R9, Part 9.2 prior to the effective date</u></p> <p><u>OR</u></p> <p><u>The Reliability Coordinator provided its new or revised SOL methodology to a requesting Reliability Coordinator in accordance with Requirement R9, Part 9.1, but was late by more than 20 calendar days but less than or equal to 30 calendar days.</u></p>	<p><u>The Reliability Coordinator failed to provide its new or revised SOL methodology to four or more of the parties specified in Requirement R9, Part 9.2 prior to the effective date</u></p> <p><u>OR</u></p> <p><u>The Reliability Coordinator failed to provide its new or revised SOL methodology to one or more of the parties specified in Requirement R9, Part 9.2</u></p> <p><u>OR</u></p> <p><u>The Reliability Coordinator provided its new or revised SOL methodology to a requesting Reliability Coordinator in accordance with Requirement R9, Part 9.1, but was late by more than 30 calendar days.</u></p> <p><u>OR</u></p> <p><u>The Reliability Coordinator failed to provide its new or revised SOL methodology to</u></p>

Requirement	Lower	Moderate	High	Severe
				<u>a requesting Reliability Coordinator in accordance with Requirement R9, Part 9.1.</u>



## D. Regional Variances

~~1.~~ The following Interconnection-wide Regional Difference shall be applicable in the Western Interconnection:

~~1.3.~~ As governed by the requirements of R3.3, starting with all Facilities in service, shall require the evaluation of the following multiple Facility Contingencies when establishing SOLs:

~~1.3.0~~ Simultaneous permanent phase to ground Faults on different phases of each of two adjacent transmission circuits on a multiple circuit tower, with Normal Clearing. If multiple circuit towers are used only for station entrance and exit purposes, and if they do not exceed five towers at each station, then this condition is an acceptable risk and therefore can be excluded.

~~1.3.0~~ A permanent phase to ground Fault on any generator, transmission circuit, transformer, or bus section with Delayed Fault Clearing except for bus sectionalizing breakers or bus tie breakers addressed in E1.1.7

~~1.3.0~~ Simultaneous permanent loss of both poles of a direct current bipolar Facility without an alternating current Fault.

~~1.3.0~~ The failure of a circuit breaker associated with a Remedial Action Scheme to operate when required following: the loss of any element without a Fault; or a permanent phase to ground Fault, with Normal Clearing, on any transmission circuit, transformer or bus section.

~~1.3.0~~ A non-three phase Fault with Normal Clearing on common mode Contingency of two adjacent circuits on separate towers unless the event frequency is determined to be less than one in thirty years.

~~1.3.0~~ A common mode outage of two generating units connected to the same switchyard, not otherwise addressed by FAC-011.

~~1.3.0~~ The loss of multiple bus sections as a result of failure or delayed clearing of a bus tie or bus sectionalizing breaker to clear a permanent Phase to Ground Fault.

~~1.3.~~ SOLs shall be established such that for multiple Facility Contingencies in E1.1.1 through E1.1.5 operation within the SOL shall provide system performance consistent with the following:

~~1.3.0~~ All Facilities are operating within their applicable Post Contingency thermal, frequency and voltage limits.

~~1.3.0~~ Cascading does not occur.

~~1.3.1 Uncontrolled separation of the system does not occur.~~

~~1.3.1 The system demonstrates transient, dynamic and voltage stability.~~

~~1.3.1 Depending on system design and expected system impacts, the controlled interruption of electric supply to customers (load shedding), the planned removal from service of certain generators, and/or the curtailment of contracted firm (non-recallable reserved) electric power transfers may be necessary to maintain the overall security of the interconnected transmission systems.~~

~~1.3.1 Interruption of firm transfer, Load or system reconfiguration is permitted through manual or automatic control or protection actions.~~

~~1.3.1 To prepare for the next Contingency, system adjustments are permitted, including changes to generation, Load and the transmission system topology when determining limits.~~

~~1.3. SOLs shall be established such that for multiple Facility Contingencies in E1.1.6 through E1.1.7 operation within the SOL shall provide system performance consistent with the following with respect to impacts on other systems:~~

~~1.3.1 Cascading does not occur.~~

~~1.3. The Western Interconnection may make changes (performance category adjustments) to the Contingencies required to be studied and/or the required responses to Contingencies for specific facilities based on actual system performance and robust design. Such changes will apply in determining SOLs.~~

None.

## E. Associated Documents

None. Implementation Plan

## Version History

Version	Date	Action	Change Tracking
1	November 1, 2006	Adopted by Board	New
2		<p>Changed the effective date to October 1, 2008</p> <p>Changed "Cascading Outage" to "Cascading"</p> <p>Replaced Levels of Non-compliance with Violation Severity Levels</p> <p>Corrected footnote 1 to reference FAC-011 rather than FAC-010</p>	Revised
2	June 24, 2008	Adopted by Board: FERC Order 705	Revised
2	January 22, 2010	Updated effective date and footer to April 29, 2009 based on the March 20, 2009 FERC Order	Update
2	February 7, 2013	R5 and associated elements approved by NERC Board of Trustees for retirement as part of the Paragraph 81 project (Project 2013-02) pending applicable regulatory approval.	
2	November 21, 2013	R5 and associated elements approved by FERC for retirement as part of the Paragraph 81 project (Project 2013-02)	
2	February 24, 2014	Updated VSLs based on June 24, 2013 approval.	
3	November 13, 2014	Adopted by the NERC Board	Replaced references to Special Protection System and SPS with Remedial Action Scheme and RAS
3	November 19, 2015	FERC Order issued approving FAC-011-3. Docket No. RM15-13-000.	

4	May 13, 2021	Adopted by the NERC Board of Trustees	Revised under Project 2015-09
---	--------------	---------------------------------------	-------------------------------

Exhibit A-2

FAC-014-3 (Clean and Redline to Last Approved)

## A. Introduction

1. **Title:** Establish and Communicate System Operating Limits
2. **Number:** FAC-014-3
3. **Purpose:** To ensure that System Operating Limits (SOLs) used in the reliable operation of the Bulk Electric System (BES) are determined based on an established methodology or methodologies and that Planning Assessment performance criteria is coordinated with these methodologies.
4. **Applicability:**
  - 4.1. **Functional Entities:**
    - 4.1.1. Planning Coordinator
    - 4.1.2. Reliability Coordinator
    - 4.1.3. Transmission Operator
    - 4.1.4. Transmission Planner
5. **Effective Date:** See Implementation Plan for [Project 2015-09](#).

## B. Requirements and Measures

- R1.** Each Reliability Coordinator shall establish Interconnection Reliability Operating Limits (IROLs) for its Reliability Coordinator Area in accordance with its System Operating Limit methodology (SOL methodology). *[Violation Risk Factor: High ] [Time Horizon: Operations Planning]*
- M1.** Acceptable evidence may include, but is not limited to, dated electronic or hard copy documentation that demonstrates the Reliability Coordinator established IROLs in accordance with its SOL methodology.
- R2.** Each Transmission Operator shall establish System Operating Limits (SOLs) for its portion of the Reliability Coordinator Area in accordance with its Reliability Coordinator's SOL methodology. *[Violation Risk Factor: Medium] [Time Horizon: Operations Planning]*
- M2.** Acceptable evidence may include, but is not limited to, dated electronic or hard copy documentation that demonstrates the Transmission Operator established SOLs in accordance with its Reliability Coordinator's SOL methodology.
- R3.** Each Transmission Operator shall provide its SOLs to its Reliability Coordinator. *[Violation Risk Factor: Medium] [Time Horizon: Operations Planning, Same-day Operations, Real-Time Operations]*
- M3.** Acceptable evidence may include, but is not limited to, dated electronic or hard copy documentation that demonstrates the Transmission Operator provided its SOLs.

- R4.** Each Reliability Coordinator shall establish stability limits when an identified instability impacts adjacent Reliability Coordinator Areas or more than one Transmission Operator in its Reliability Coordinator Area in accordance with its SOL methodology. *[Violation Risk Factor: High] [Time Horizon: Operations Planning]*
- M4.** Acceptable evidence may include, but is not limited to, dated electronic or hard copy documentation that demonstrates the Reliability Coordinator established stability limits in accordance with Requirement R4.
- R5.** Each Reliability Coordinator shall provide: *[Violation Risk Factor: High] [Time Horizon: Operations Planning, Same-day Operations, Real-Time Operations]*
- 5.1** Each Planning Coordinator and each Transmission Planner within its Reliability Coordinator Area, the SOLs for its Reliability Coordinator Area (including the subset of SOLs that are IROLs) at least once every twelve calendar months. *[Time Horizon: Operations Planning]*
- 5.2** Each impacted Planning Coordinator and each impacted Transmission Planner within its Reliability Coordinator Area, the following information for each established stability limit and each established IROL at least once every twelve calendar months: *[Time Horizon: Operations Planning]*
- 5.2.1** The value of the stability limit or IROL;
- 5.2.2** Identification of the Facilities that are critical to the derivation of the stability limit or the IROL;
- 5.2.3** The associated IROL  $T_v$  for any IROL;
- 5.2.4** The associated critical Contingency(ies);
- 5.2.5** A description of system conditions associated with the stability limit or IROL; and
- 5.2.6** The type of limitation represented by the stability limit or IROL (*e.g.*, voltage collapse, angular stability).
- 5.3** Each impacted Transmission Operator within its Reliability Coordinator Area, the value of the stability limits established pursuant to Requirement R4 and each IROL established pursuant to Requirement R1, in an agreed upon time frame necessary for inclusion in the Transmission Operator’s Operational Planning Analyses, Real-time monitoring, and Real-time Assessments. *[Time Horizon: Operations Planning, Same-day Operations, Real-Time Operations]*
- 5.4** Each impacted Transmission Operator within its Reliability Coordinator Area, the information identified in Requirement R5 Parts 5.2.2 – 5.2.6 for each established stability limit and each established IROL, and any updates to that information within an agreed upon time frame necessary for inclusion in the Transmission Operator’s Operational Planning Analyses. *[Time Horizon: Operations Planning, Same-day Operations, Real-Time Operations]*

- 5.5** Each requesting Transmission Operator within its Reliability Coordinator Area, requested SOL information for its Reliability Coordinator Area, on a mutually agreed upon schedule. *[Time Horizon: Operations Planning]*
- 5.6** Each impacted Generator Owner or Transmission Owner, within its Reliability Coordinator Area, with a list of their Facilities that have been identified as critical to the derivation of an IROL and its associated critical contingencies at least once every twelve calendar months. *[Time Horizon: Operations Planning]*
- M5.** Acceptable evidence may include, but is not limited to, dated electronic or hard copy documentation, posting to a secure website, or other electronic means, that demonstrates the Reliability Coordinator provided the information in accordance with Requirement R5.
- R6.** Each Planning Coordinator and each Transmission Planner shall implement a documented process to use Facility Ratings, System steady-state voltage limits and stability criteria in its Planning Assessment of Near-Term Transmission Planning Horizon that are equally limiting or more limiting than the criteria for Facility Ratings, System Voltage Limits and stability described in its respective Reliability Coordinator's SOL methodology. *[Violation Risk Factor: Medium] [Time Horizon: Long-term Planning]*
- The Planning Coordinator may use less limiting Facility Ratings, System steady-state voltage limits and stability criteria if it provides a technical rationale to each affected Transmission Planner, Transmission Operator and Reliability Coordinator.
  - The Transmission Planner may use less limiting Facility Ratings, System steady-state voltage limits and stability criteria if it provides a technical rationale to each affected Planning Coordinator, Transmission Operator and Reliability Coordinator.
- M6.** Acceptable evidence may include, but is not limited to, dated electronic or hard copy documentation demonstrating the Planning Coordinator and Transmission Planner implemented its documented process in accordance with Requirement R6.
- R7.** Each Planning Coordinator and each Transmission Planner shall annually communicate the following information for Corrective Action Plans developed to address any instability identified in its Planning Assessment of the Near-Term Transmission Planning Horizon to each impacted Transmission Operator and Reliability Coordinator. This communication shall include: *[Violation Risk Factor: Medium] [Time Horizon: Long-term Planning]*
- 7.1** The Corrective Action Plan developed to mitigate the identified instability, including any automatic control or operator-assisted actions (such as Remedial Action Schemes, under voltage load shedding, or any Operating Procedures);
  - 7.2** The type of instability addressed by the Corrective Action Plan (e.g. steady-state and/or transient voltage instability, angular instability including generating unit loss of synchronism and/or unacceptable damping);
  - 7.3** The associated stability criteria violation requiring the Corrective Action Plan (e.g. violation of transient voltage response criteria or damping rate criteria);



- 7.4** The planning event Contingency(ies) associated with the identified instability requiring the Corrective Action Plan;
  - 7.5** The System conditions and Facilities associated with the identified instability requiring the Corrective Action Plan.
- M7.** Acceptable evidence may include, but is not limited to, dated electronic or hard copy documentation demonstrating the Planning Coordinator and Transmission Planner communicated the information in accordance with Requirement R7.
- R8.** Each Planning Coordinator and each Transmission Planner shall annually communicate to each impacted Transmission Owner and Generation Owner a list of their Facilities that comprise the planning event Contingency(ies) that would cause instability, Cascading or uncontrolled separation that adversely impacts the reliability of the BES as identified in its Planning Assessment of the Near-Term Transmission Planning Horizon. *[Violation Risk Factor: Medium] [Time Horizon: Long- term Planning]*
- M8.** Acceptable evidence may include, but is not limited to, dated electronic or hard copy documentation demonstrating the Planning Coordinator and Transmission Planner communicated the information in accordance with Requirement R8.

## C. Compliance

### 1. Compliance Monitoring Process

#### 1.1. Compliance Enforcement Authority:

“Compliance Enforcement Authority” means NERC or the Regional Entity, or any entity as otherwise designated by an Applicable Governmental Authority, in their respective roles of monitoring and/or enforcing compliance with mandatory and enforceable Reliability Standards in their respective jurisdictions.

#### 1.2. Evidence Retention:

The following evidence retention period(s) identify the period of time an entity is required to retain specific evidence to demonstrate compliance. For instances where the evidence retention period specified below is shorter than the time since the last audit, the Compliance Enforcement Authority may ask an entity to provide other evidence to show that it was compliant for the full-time period since the last audit.

The applicable entity shall keep data or evidence to show compliance as identified below unless directed by its Compliance Enforcement Authority to retain specific evidence for a longer period of time as part of an investigation.

- The Reliability Coordinator, Transmission Operator, Transmission Planner, Planning Coordinator shall keep data or evidence of Requirements R1 through R8 for the current year plus the previous 12 calendar months.

#### 1.3. Compliance Monitoring and Enforcement Program

As defined in the NERC Rules of Procedure, “Compliance Monitoring and Enforcement Program” refers to the identification of the processes that will be used to evaluate data or information for the purpose of assessing performance or outcomes with the associated Reliability Standard.

## Violation Severity Levels

R #	Violation Severity Levels			
	Lower VSL	Moderate VSL	High VSL	Severe VSL
<b>R1.</b>	N/A	N/A	N/A	The Reliability Coordinator failed to establish Interconnection Reliability Operating Limits (IROLs) for its Reliability Coordinator Area in accordance with its System Operating Limit Methodology (“SOL methodology”).
<b>R2.</b>	N/A	N/A	N/A	The Transmission Operator failed to establish SOLs for its portion of the Reliability Coordinator Area in accordance with its Reliability Coordinator’s SOL methodology.
<b>R3.</b>	N/A	N/A	The Transmission Operator provided its SOLs to its Reliability Coordinator, but failed to provide its SOLs at the periodicity at which the Reliability Coordinator needs such information to perform its reliability functions.	The Transmission Operator failed to provide its SOLs to its Reliability Coordinator.

<p><b>R4.</b></p>	<p>N/A</p>	<p>N/A</p>	<p>N/A</p>	<p>The Reliability Coordinator failed to establish stability limits to be used in operations when the limit impacts an adjacent Reliability Coordinator or more than one Transmission Operator in its Reliability Coordinator Area in accordance with its SOL methodology.</p>
<p><b>R5.</b></p>	<p>The Reliability Coordinator failed to provide one of the items listed in Requirement R5, Parts 5.1 through 5.6.</p>	<p>The Reliability Coordinator failed to provide two of the items listed in Requirement R5, Parts 5.1 through 5.6.</p>	<p>The Reliability Coordinator failed to provide three of the items listed in Requirement R5, Parts 5.1 through 5.6.</p>	<p>The Reliability Coordinator failed to provide four or more of the items listed in Requirement R5, Parts 5.1 through 5.6.</p>
<p><b>R6.</b></p>	<p>N/A</p>	<p>N/A</p>	<p>The Planning Coordinator or a Transmission Planner used less limiting Facility Ratings, System steady state voltage limits or stability criteria than the criteria for Facility Ratings, System Voltage Limits or stability described in its respective Reliability Coordinator’s SOL methodology, but failed to provide a technical rationale for allowing the use of less</p>	<p>The Planning Coordinator or a Transmission Planner failed to implement a process to ensure that Facility Ratings, System steady state voltage limits or stability criteria used in Planning Assessment are equally limiting or more limiting than the criteria for Facility Ratings, System Voltage Limits or stability described in its respective</p>

			limiting Facility Ratings, System Voltage Limits or stability criteria	Reliability Coordinator’s SOL methodology.
<b>R7.</b>	The Planning Coordinator or a Transmission Planner communicated the identified instability to each impacted Reliability Coordinator and Transmission Operator, but the communication did not contain one of the elements listed in Requirement R7, Parts 7.1 through 7.5.	The Planning Coordinator or a Transmission Planner communicated the identified instability to each impacted Reliability Coordinator and Transmission Operator, but the communication did not contain two of the elements listed in Requirement R7, Parts 7.1 through 7.5.	The Planning Coordinator or a Transmission Planner communicated the identified instability to each impacted Reliability Coordinator and Transmission Operator, but the communication did not contain three elements listed in Requirement R7, Parts 7.1 through 7.5.	The Planning Coordinator or a Transmission Planner communicated the identified instability to each impacted Reliability Coordinator and Transmission Operator, but the communication did not contain four or more of the elements listed in Requirement R7, Parts 7.1 through 7.5.  OR The Planning Coordinator or a Transmission Planner failed to communicate any identified instability, to each impacted Reliability Coordinator and Transmission Operator.
<b>R8.</b>			The Planning Coordinator or a Transmission Planner provided the instability, Cascading or uncontrolled separation information listed in Requirement R8 to the applicable Transmission	The Planning Coordinator or a Transmission Planner failed to provide the instability, Cascading or uncontrolled separation information listed in Requirement R8 to the applicable Transmission

			Owner, and Generation Owner, but failed to provide them annually.	Owner, and Generation Owner.
--	--	--	---	------------------------------

**D. Regional Variances**

None.

**E. Interpretations**

None.

**F. Associated Documents**

Implementation Plan

## Version History

Version	Date	Action	Change Tracking
1	November 1, 2006	Adopted by Board	New
2		Changed the effective date to January 1, 2009 Replaced Levels of Non-compliance with Violation Severity Levels	Revised
2	June 24, 2008	Adopted by Board: FERC Order	Revised
2	January 22, 2010	Updated effective date and footer to April 29, 2009 based on the March 20, 2009 FERC Order	Update
2	April 29, 2015 – July 23, 2015	Incorrectly included TOP as the applicable function for Requirement R5. 7/23/15: Corrected to designate R5 as: RC, PA and TP.	Revised
3	May 13, 2021	Adopted by Board of Trustees	Revised under Project 2015-09

## A. Introduction

1. **Title:** Establish and Communicate System Operating Limits
2. **Number:** FAC-014-23
3. **Purpose:** To ensure that System Operating Limits (SOLs) used in the reliable ~~planning and~~ operation of the Bulk Electric System (BES) are determined based on an established methodology or methodologies and that Planning Assessment performance criteria is coordinated with these methodologies.
4. **Applicability**
  - 4.1. **Functional Entities**
    - 4.1.1. Planning Coordinator
    - 4.1.2. Reliability Coordinator
    - 4.1.3. Transmission Operator
    - 4.1.4. Transmission Planner
5. **Effective Date:** April 29, 2009 See Implementation Plan for Project 2015-09.

## B. Requirements and Measures

- R1. ~~The Each~~ Reliability Coordinator shall establish ensure that SOLs, including Interconnection Reliability Operating Limits (IROLs) for its Reliability Coordinator Area in accordance with its System Operating Limit methodology (SOL methodology). [Violation Risk Factor: High ] [Time Horizon: Operations Planning] ~~for its Reliability Coordinator Area are established and that the SOLs (including Interconnection Reliability Operating Limits) are consistent with its SOL Methodology~~
- M1. Acceptable evidence may include, but is not limited to, dated electronic or hard copy documentation that demonstrates the Reliability Coordinator established IROLs in accordance with its SOL methodology. The Reliability Coordinator, Planning Authority, Transmission Operator, and Transmission Planner shall each be able to demonstrate that it developed its SOLs (including the subset of SOLs that are IROLs) consistent with the applicable SOL Methodology in accordance with Requirements 1 through 4.
- R2. ~~The Each~~ Transmission Operator shall establish System Operating Limits (SOLs) for its portion of the (as directed by its Reliability Coordinator) Area in accordance with for its portion of the Reliability Coordinator's Area that are consistent with its Reliability Coordinator's SOL Methodology. [Violation Risk Factor: Medium] [Time Horizon: Operations Planning]
- M2. Acceptable evidence may include, but is not limited to, dated electronic or hard copy documentation that demonstrates the Transmission Operator established SOLs in accordance with its Reliability Coordinator's SOL methodology. The Reliability



~~Coordinator, Planning Authority, Transmission Operator, and Transmission Planner shall each have evidence that its SOLs (including the subset of SOLs that are IROLs) were supplied in accordance with schedules supplied by the requestors of such SOLs as specified in Requirement 5.~~

~~**R3.** The Each Planning Authority Transmission Operator shall provide its establish SOLs, to its Reliability Coordinator Coordinator including IROLs, for its Planning Authority Area that are consistent with its SOL Methodology. [Violation Risk Factor: Medium] [Time Horizon: Operations Planning, Same-day Operations, Real-Time Operations]~~

~~**M3.** Acceptable evidence may include, but is not limited to, dated electronic or hard copy documentation that demonstrates the Transmission Operator provided its SOLs. The Planning Authority shall have evidence it identified a list of multiple contingencies (if any) and their associated stability limits and provided the list and the limits to its Reliability Coordinators in accordance with Requirement 6.~~

~~**R4.** The Transmission Planner Each Reliability Coordinator shall establish stability limits when an identified instability impacts adjacent Reliability Coordinator Areas or more than one Transmission Operator in its Reliability Coordinator Area in accordance with SOLs, including IROLs, for its Transmission Planning Area that are consistent with its Planning Authority's SOL Methodology. [Violation Risk Factor: High] [Time Horizon: Operations Planning]~~

~~**M1-M4.** Acceptable evidence may include, but is not limited to, dated electronic or hard copy documentation that demonstrates the Reliability Coordinator established stability limits in accordance with Requirement R4.~~

~~**R3-R5.** Each The Reliability Coordinator, Planning Authority, and Transmission Planner shall each provide its SOLs and IROLs to those entities that have a reliability-related need for those limits and provide a written request that includes a schedule for delivery of those limits as follows: [Violation Risk Factor: High] [Time Horizon: Operations Planning, Same-day Operations, Real-Time Operations]~~

~~**5.1** The Reliability Each Planning Coordinator and each Transmission Planner within shall provide its SOLs (including the subset of SOLs that are IROLs) to adjacent Reliability Coordinator Area and Reliability Coordinators who indicate a reliability-related need for those limits, and to the SOLs Transmission Operators, Transmission Planners, Transmission Service Providers and Planning Authorities within for its Reliability Coordinator Area (including including the subset of SOLs that are For each IROLs) at least once every twelve calendar months. [Time Horizon: Operations Planning], the Reliability Coordinator shall provide the following supporting information:~~

~~**5.2** Identification and status of the associated Facility (or group of Facilities) that is (are) critical to the derivation of the IROL.~~

~~The value of the IROL and its associated  $T_v$ .~~

~~The associated Contingency(ies).~~

~~The type of limitation represented by the IROL (e.g., voltage collapse, angular stability).~~

~~Each impacted Planning Coordinator and each impacted Transmission Operator Planner shall provide any SOLs it developed to within its Reliability Coordinator Area, and to the following information for each established stability limit and each established IROL at least once every twelve calendar months: [Time Horizon: Operations Planning] Transmission Service Providers that share its portion of the Reliability Coordinator Area.~~

~~5.2.1 The value of the stability limit or IROL;~~

~~5.2.2 Identification of the Facilities that are critical to the derivation of the stability limit or the IROL;~~

~~5.2.3 The associated IROL  $T_v$  for any IROL;~~

~~5.2.4 The associated critical Contingency(ies);~~

~~5.2.5 A description of system conditions associated with the stability limit or IROL; and~~

~~5.2.6 The type of limitation represented by the stability limit or IROL (e.g., voltage collapse, angular stability).~~

~~5.3 Each impacted Transmission Operator within The Planning Authority shall provide its SOLs (including the subset of SOLs that are IROLs) to adjacent Planning Authorities, and to Transmission Planners, Transmission Service Providers, Transmission Operators and Reliability Coordinator Areas, the value of the stability limits —established pursuant to Requirement R4 and each IROL established pursuant to Requirement R1, in an agreed upon time frame necessary for inclusion in the Transmission Operator’s Operational Planning Analyses, Real-time monitoring, and Real-time Assessments. [Time Horizon: Operations Planning, Same-day Operations, Real-Time Operations] that work within its Planning Authority Area.~~

~~5.4 Each impacted The Transmission Planner-Operator shall provide its SOLs (including the subset of SOLs that are IROLs) to within its Planning Authority, Reliability Coordinators Area, the information identified in —Requirement R5 Parts 5.2.2 – 5.2.6 for each established stability limit and each established IROL, and any updates to that information within an agreed upon time frame necessary for inclusion in the Transmission Operator’s Operational Planning Analyses. [Time Horizon: Operations Planning, Same-day Operations, Real-Time Operations] Transmission Operators, and Transmission Service Providers that work within its Transmission Planning Area and to adjacent Transmission Planners.~~

~~5.5 Each requesting Transmission Operator within its Reliability Coordinator Area, requested SOL information for its Reliability Coordinator Area, on a mutually agreed upon schedule. [Time Horizon: Operations Planning]~~

5.6 Each impacted Generator Owner or Transmission Owner, within its Reliability Coordinator Area, with a list of their Facilities that have been identified as critical to the derivation of an IROL and its associated critical contingencies at least once every twelve calendar months. [Time Horizon: Operations Planning]

M2-M5. Acceptable evidence may include, but is not limited to, dated electronic or hard copy documentation, posting to a secure website, or other electronic means, that demonstrates the Reliability Coordinator provided the information in accordance with Requirement R5.

R4,R6. The Each Planning Authority Coordinator and each Transmission Planner shall implement a documented process to use Facility Ratings, System steady-state voltage limits and stability criteria in its Planning Assessment of Near Term Transmission Planning Horizon that are equally limiting or more limiting than the criteria for Facility Ratings, System Voltage Limits and stability described in its respective Reliability Coordinator's SOL methodology. [Violation Risk Factor: Medium] [Time Horizon: Long-term Planning] shall identify the subset of multiple contingencies (if any), from Reliability Standard TPL 003 which result in stability limits.

- The Planning Coordinator may Authority use less limiting Facility Ratings, System steady-state voltage limits and stability criteria if it provides a technical rationale to each affected Transmission Planner, Transmission Operator and Reliability Coordinator. shall provide this list of multiple contingencies and the associated stability limits to the Reliability Coordinators that monitor the facilities associated with these contingencies and limits.
- If the Transmission Planner may use less limiting Facility Ratings, System steady-state voltage limits and stability criteria if it provides a technical rationale to each affected Planning Coordinator, Transmission Operator and Planning Authority does not identify any stability-related multiple contingencies, the Planning Authority shall so notify the Reliability Coordinator.

M6. Acceptable evidence may include, but is not limited to, dated electronic or hard copy documentation demonstrating the Planning Coordinator and Transmission Planner implemented its documented process in accordance with Requirement R6.

R7. Each Planning Coordinator and each Transmission Planner shall annually communicate the following information for Corrective Action Plans developed to address any instability identified in its Planning Assessment of the Near-Term Transmission Planning Horizon to each impacted Transmission Operator and Reliability Coordinator. This communication shall include: [Violation Risk Factor: Medium] [Time Horizon: Long-term Planning]

7.1 The Corrective Action Plan developed to mitigate the identified instability, including any automatic control or operator-assisted actions (such as Remedial Action Schemes, under voltage load shedding, or any Operating Procedures);

- 7.2 The type of instability addressed by the Corrective Action Plan (e.g. steady-state and/or transient voltage instability, angular instability including generating unit loss of synchronism and/or unacceptable damping);
- 7.3 The associated stability criteria violation requiring the Corrective Action Plan (e.g. violation of transient voltage response criteria or damping rate criteria);
- 7.4 The planning event Contingency(ies) associated with the identified instability requiring the Corrective Action Plan;
- 7.5 The System conditions and Facilities associated with the identified instability requiring the Corrective Action Plan.
- M7. Acceptable evidence may include, but is not limited to, dated electronic or hard copy documentation demonstrating the Planning Coordinator and Transmission Planner communicated the information in accordance with Requirement R7.
- R8. Each Planning Coordinator and each Transmission Planner shall annually communicate to each impacted Transmission Owner and Generation Owner a list of their Facilities that comprise the planning event Contingency(ies) that would cause instability, Cascading or uncontrolled separation that adversely impacts the reliability of the BES as identified in its Planning Assessment of the Near-Term Transmission Planning Horizon. [Violation Risk Factor: Medium] [Time Horizon: Long- term Planning]
- M3,M8. Acceptable evidence may include, but is not limited to, dated electronic or hard copy documentation demonstrating the Planning Coordinator and Transmission Planner communicated the information in accordance with Requirement R8.

## **C. Measures**

- ~~M4.M1. The Reliability Coordinator, Planning Authority, Transmission Operator, and Transmission Planner shall each be able to demonstrate that it developed its SOLs (including the subset of SOLs that are IROLs) consistent with the applicable SOL Methodology in accordance with Requirements 1 through 4.~~
- ~~M5.M1. The Reliability Coordinator, Planning Authority, Transmission Operator, and Transmission Planner shall each have evidence that its SOLs (including the subset of SOLs that are IROLs) were supplied in accordance with schedules supplied by the requestors of such SOLs as specified in Requirement 5.~~
- ~~M6.M1. The Planning Authority shall have evidence it identified a list of multiple contingencies (if any) and their associated stability limits and provided the list and the limits to its Reliability Coordinators in accordance with Requirement 6.~~

## **G.C. Compliance**

1. **Compliance Monitoring Process**
  - 1.1. Compliance Enforcement Authority: Compliance Monitoring Responsibility

“Compliance Enforcement Authority” means NERC or the Regional Entity, or any entity as otherwise designated by an Applicable Governmental Authority, in their respective roles of monitoring and/or enforcing compliance with mandatory and enforceable Reliability Standards in their respective jurisdictions. Regional Reliability Organization

**1.2. Evidence Retention:~~Compliance Monitoring Period and Reset Time Frame~~**

The following evidence retention period(s) identify the period of time an entity is required to retain specific evidence to demonstrate compliance. For instances where the evidence retention period specified below is shorter than the time since the last audit, the Compliance Enforcement Authority may ask an entity to provide other evidence to show that it was compliant for the full-time period since the last audit.

The applicable entity shall keep data or evidence to show compliance as identified below unless directed by its Compliance Enforcement Authority to retain specific evidence for a longer period of time as part of an investigation.

- The Reliability Coordinator, Transmission Operator, Transmission Planner, Planning Coordinator shall keep data or evidence of Requirements R1 through R8 for the current year plus the previous 12 calendar months.

~~The Reliability Coordinator, Planning Authority, Transmission Operator, and Transmission Planner shall each verify compliance through self-certification submitted to its Compliance Monitor annually. The Compliance Monitor may conduct a targeted audit once in each calendar year (January — December) and an investigation upon a complaint to assess performance.~~

~~The Performance Reset Period shall be twelve months from the last finding of non-compliance.~~

**1.5.1.3. Compliance Monitoring and Enforcement Program~~Data Retention~~**

As defined in the NERC Rules of Procedure, “Compliance Monitoring and Enforcement Program” refers to the identification of the processes that will be used to evaluate data or information for the purpose of assessing performance or outcomes with the associated Reliability Standard.

~~The Reliability Coordinator, Planning Authority, Transmission Operator, and Transmission Planner shall each keep documentation for 12 months. In addition, entities found non-compliant shall keep information related to non-compliance until found compliant.~~

~~The Compliance Monitor shall keep the last audit and all subsequent compliance records.~~

~~**Additional Compliance Information**~~

~~The Reliability Coordinator, Planning Authority, Transmission Operator, and Transmission Planner shall each make the following available for inspection during a targeted audit by the Compliance Monitor or within 15 business days of a request as part of an investigation upon complaint:~~

~~**1.6.0** SOL Methodology(ies)~~

~~**1.6.0** SOLs, including the subset of SOLs that are IROLs and the IROLs supporting information~~

~~**1.6.0** Evidence that SOLs were distributed~~

~~**1.6.0** Evidence that a list of stability related multiple contingencies and their associated limits were distributed~~

~~**1.6.0** Distribution schedules provided by entities that requested SOLs~~

### Violation Severity Levels:

R #	Violation Severity Levels			
	Lower VSL	Moderate VSL	High VSL	Severe VSL
R1.	<del>N/A There are SOLs, for the Reliability Coordinator Area, but from 1% up to but less than 25% of these SOLs are inconsistent with the Reliability Coordinator's SOL Methodology. (R1)</del>	<del>N/A There are SOLs, for the Reliability Coordinator Area, but 25% or more, but less than 50% of these SOLs are inconsistent with the Reliability Coordinator's SOL Methodology. (R1)</del>	<del>N/A There are SOLs, for the Reliability Coordinator Area, but 50% or more, but less than 75% of these SOLs are inconsistent with the Reliability Coordinator's SOL Methodology. (R1)</del>	<del>The Reliability Coordinator failed to establish Interconnection Reliability Operating Limits (IROLs) for its Reliability Coordinator Area in accordance with its System Operating Limit Methodology ("SOL methodology"). There are SOLs for the Reliability Coordinator Area, but 75% or more of these SOLs are inconsistent with the Reliability Coordinator's SOL Methodology. (R1)</del>
R2.	<del>N/A The Transmission Operator has established SOLs for its portion of the Reliability Coordinator Area, but from 1% up to but less than 25% of these SOLs are inconsistent with the Reliability Coordinator's SOL Methodology. (R2)</del>	<del>N/A The Transmission Operator has established SOLs for its portion of the Reliability Coordinator Area, but 25% or more, but less than 50% of these SOLs are inconsistent with the Reliability Coordinator's SOL Methodology. (R2)</del>	<del>N/A The Transmission Operator has established SOLs for its portion of the Reliability Coordinator Area, but 50% or more, but less than 75% of these SOLs are inconsistent with the Reliability Coordinator's SOL Methodology. (R2)</del>	<del>The Transmission Operator failed to establish SOLs for its portion of the Reliability Coordinator Area in accordance with its Reliability Coordinator's SOL methodology. The Transmission Operator has established SOLs for its portion of the Reliability</del>

				Coordinator Area, but 75% or more of these SOLs are inconsistent with the Reliability Coordinator's SOL Methodology. (R2)
R3.	<del>N/A</del> There are SOLs, for the Planning Coordinator Area, but from 1% up to, but less than, 25% of these SOLs are inconsistent with the Planning Coordinator's SOL Methodology. (R3)	<del>N/A</del> There are SOLs, for the Planning Coordinator Area, but 25% or more, but less than 50% of these SOLs are inconsistent with the Planning Coordinator's SOL Methodology. (R3)	<del>The Transmission Operator provided its SOLs to its Reliability Coordinator, but failed to provide its SOLs at the periodicity at which the Reliability Coordinator needs such information to perform its reliability functions.</del> There are SOLs for the Planning Coordinator Area, but 50% or more, but less than 75% of these SOLs are inconsistent with the Planning Coordinator's SOL Methodology. (R3)	<del>The Transmission Operator failed to provide its SOLs to its Reliability Coordinator.</del> There are SOLs, for the Planning Coordinator Area, but 75% or more of these SOLs are inconsistent with the Planning Coordinator's SOL Methodology. (R3)
R4.	<del>N/A</del> The Transmission Planner has established SOLs for its portion of the Planning Coordinator Area, but up to 25% of these SOLs are inconsistent with the Planning Coordinator's SOL Methodology. (R4)	<del>N/A</del> The Transmission Planner has established SOLs for its portion of the Planning Coordinator Area, but 25% or more, but less than 50% of these SOLs are inconsistent with the Planning Coordinator's SOL Methodology. (R4)	<del>N/A</del> The Transmission Planner has established SOLs for its portion of the Reliability Coordinator Area, but 50% or more, but less than 75% of these SOLs are inconsistent with the Planning Coordinator's SOL Methodology. (R4)	<del>The Reliability Coordinator failed to establish stability limits to be used in operations when the limit impacts an adjacent Reliability Coordinator or more than one Transmission Operator in its Reliability Coordinator Area in accordance with its SOL methodology.</del> The



				Transmission Planner has established SOLs for its portion of the Planning Coordinator Area, but 75% or more of these SOLs are inconsistent with the Planning Coordinator's SOL Methodology. (R4)
R5.	<u>The Reliability Coordinator failed to provide one of the items listed in Requirement R5, Parts 5.1 through 5.6.</u> The responsible entity provided its SOLs (including the subset of SOLs that are IROs) to all the requesting entities but missed meeting one or more of the schedules by less than 15 calendar days. (R5)	<u>The Reliability Coordinator failed to provide two of the items listed in Requirement R5, Parts 5.1 through 5.6.</u> One of the following: The responsible entity provided its SOLs (including the subset of SOLs that are IROs) to all but one of the requesting entities within the schedules provided. (R5) OR The responsible entity provided its SOLs to all the requesting entities but missed meeting one or more of the schedules for 15 or more but less than 30 calendar days. (R5) OR The supporting information provided with the IROs does not address 5.1.4	<u>The Reliability Coordinator failed to provide three of the items listed in Requirement R5, Parts 5.1 through 5.6.</u> One of the following: The responsible entity provided its SOLs (including the subset of SOLs that are IROs) to all but two of the requesting entities within the schedules provided. (R5) OR The responsible entity provided its SOLs to all the requesting entities but missed meeting one or more of the schedules for 30 or more but less than 45 calendar days. (R5) OR The supporting information provided with the IROs does not address 5.1.3	<u>The Reliability Coordinator failed to provide four or more of the items listed in Requirement R5, Parts 5.1 through 5.6.</u> One of the following: The responsible entity failed to provide its SOLs (including the subset of SOLs that are IROs) to more than two of the requesting entities within 45 calendar days of the associated schedules. (R5) OR The supporting information provided with the IROs does not address 5.1.1 and 5.1.2.
R6.	<u>N/A</u> The Planning Authority failed to notify the Reliability Coordinator in accordance with R6.2	<u>N/A</u> Not applicable.	<u>The Planning Coordinator or a Transmission Planner used less limiting Facility Ratings, System steady state voltage</u>	<u>The Planning Coordinator or a Transmission Planner failed to implement a process to ensure that Facility Ratings,</u>

			<p><u>limits or stability criteria than the criteria for Facility Ratings, System Voltage Limits or stability described in its respective Reliability Coordinator’s SOL methodology, but failed to provide a technical rationale for allowing the use of less limiting Facility Ratings, System Voltage Limits or stability criteria</u>The Planning Authority identified the subset of multiple contingencies which result in stability limits <del>but</del> did not provide the list of multiple contingencies and associated limits to one Reliability Coordinator that monitors the Facilities associated with these limits. (R6.1)</p>	<p><u>System steady state voltage limits or stability criteria used in Planning Assessment are equally limiting or more limiting than the criteria for Facility Ratings, System Voltage Limits or stability described in its respective Reliability Coordinator’s SOL methodology.</u>The Planning Authority did not identify the subset of multiple contingencies which result in stability limits. (R6)  OR  The Planning Authority identified the subset of multiple contingencies which result in stability limits <del>but</del> did not provide the list of multiple contingencies and associated limits to more than one Reliability Coordinator that monitors the Facilities associated with these limits. (R6.1)</p>
R7.	<u>The Planning Coordinator or a Transmission Planner communicated the identified instability to each impacted Reliability Coordinator and Transmission Operator, but the communication did not</u>	<u>The Planning Coordinator or a Transmission Planner communicated the identified instability to each impacted Reliability Coordinator and Transmission Operator, but the communication did not</u>	<u>The Planning Coordinator or a Transmission Planner communicated the identified instability to each impacted Reliability Coordinator and Transmission Operator, but the communication did not</u>	<u>The Planning Coordinator or a Transmission Planner communicated the identified instability to each impacted Reliability Coordinator and Transmission Operator, but the communication did not</u>

	<u>contain one of the elements listed in Requirement R7, Parts 7.1 through 7.5.</u>	<u>contain two of the elements listed in Requirement R7, Parts 7.1 through 7.5.</u>	<u>contain three elements listed in Requirement R7, Parts 7.1 through 7.5.</u>	<u>contain four or more of the elements listed in Requirement R7, Parts 7.1 through 7.5.</u>  <u>OR</u> <u>The Planning Coordinator or a Transmission Planner failed to communicate any identified instability, to each impacted Reliability Coordinator and Transmission Operator.</u>
<u>R8.</u>			<u>The Planning Coordinator or a Transmission Planner provided the instability, Cascading or uncontrolled separation information listed in Requirement R8 to the applicable Transmission Owner, and Generation Owner, but failed to provide them annually.</u>	<u>The Planning Coordinator or a Transmission Planner failed to provide the instability, Cascading or uncontrolled separation information listed in Requirement R8 to the applicable Transmission Owner, and Generation Owner.</u>

**H.D. Regional Variances**

None.

**I.E. Interpretations**

None.

**J.F. Associated Documents**

Implementation Plan

## Version History

Version	Date	Action	Change Tracking
1	November 1, 2006	Adopted by Board	New
2		Changed the effective date to January 1, 2009 Replaced Levels of Non-compliance with Violation Severity Levels	Revised
2	June 24, 2008	Adopted by Board: FERC Order	Revised
2	January 22, 2010	Updated effective date and footer to April 29, 2009 based on the March 20, 2009 FERC Order	Update
2	April 29, 2015 – July 23, 2015	Incorrectly included TOP as the applicable function for Requirement R5. 7/23/15: Corrected to designate R5 as: RC, PA and TP.	Revised
3	May 13, 2021	Adopted by Board of Trustees	Revised under Project 2015-09

Exhibit A-3

FAC-003-5 (Clean and Redline to Last Approved)

## A. Introduction

1. **Title:** Transmission Vegetation Management
2. **Number:** FAC-003-5
3. **Purpose:** To maintain a reliable electric transmission system by using a defense-in-depth strategy to manage vegetation located on transmission rights of way (ROW) and minimize encroachments from vegetation located adjacent to the ROW, thus preventing the risk of those vegetation-related outages that could lead to Cascading.
4. **Applicability:**
  - 4.1. **Functional Entities:**
    - 4.1.1. Applicable Transmission Owners
      - 4.1.1.1. Transmission Owners that own Transmission Facilities defined in 4.2.
    - 4.1.2. Applicable Generator Owners
      - 4.1.2.1. Generator Owners that own generation Facilities defined in 4.3.
  - 4.2. **Transmission Facilities:** Defined below (referred to as “applicable lines”), including but not limited to those that cross lands owned by federal,<sup>1</sup> state, provincial, public, private, or tribal entities:
    - 4.2.1. Each overhead transmission line operated at 200kV or higher.
    - 4.2.2. Each overhead transmission line operated below 200kV, identified by the Planning Coordinator or Transmission Planner, per its Planning Assessment of the Near-Term Transmission Planning Horizon as a Facility that if lost or degraded are expected to result in instances of instability, Cascading, or uncontrolled separation that adversely impacts the reliability of the Bulk Electric System for a planning event.
    - 4.2.3. Each overhead transmission line operated below 200 kV identified as an element of a Major Western Electricity Coordinating Council (WECC) Transfer Path in the Bulk Electric System by WECC.
    - 4.2.4. Each overhead transmission line identified above (4.2.1. through 4.2.3.) located outside the fenced area of the switchyard, station or substation and any portion of the span of the transmission line that is crossing the substation fence.

---

<sup>1</sup> EPAAct 2005 section 1211c: “Access approvals by Federal agencies.”

**4.3. Generation Facilities:** Defined below (referred to as “applicable lines”), including but not limited to those that cross lands owned by federal,<sup>2</sup> state, provincial, public, private, or tribal entities:

**4.3.1.** Overhead transmission lines that (1) extend greater than one mile or 1.609 kilometers beyond the fenced area of the generating station switchyard to the point of interconnection with a Transmission Owner’s Facility or (2) do not have a clear line of sight<sup>3</sup> from the generating station switchyard fence to the point of interconnection with a Transmission Owner’s Facility and are:

**4.3.1.1.** Operated at 200kV or higher; or

**4.3.1.2.** Operated below 200kV and are identified by the Planning Coordinator or Transmission Planner, per its Planning Assessment of the Near-Term Transmission Planning Horizon as a Facility that if lost or degraded are expected to result in instances of instability, Cascading, or uncontrolled separation that adversely impacts the reliability of the Bulk Electric System for a planning event; or

**4.3.1.3.** Operated below 200 kV identified as an element of a Major WECC Transfer Path in the Bulk Electric System by WECC.

**5. Effective Date:** See Implementation Plan

**6. Background:** This standard uses three types of requirements to provide layers of protection to prevent vegetation related outages that could lead to Cascading:

- a) Performance-based defines a particular reliability objective or outcome to be achieved. In its simplest form, a results-based requirement has four components: *who, under what conditions (if any), shall perform what action, to achieve what particular bulk power system performance result or outcome?*
- b) Risk-based preventive requirements to reduce the risks of failure to acceptable tolerance levels. A risk-based reliability requirement should be framed as: *who, under what conditions (if any), shall perform what action, to achieve what particular result or outcome that reduces a stated risk to the reliability of the bulk power system?*
- c) Competency-based defines a minimum set of capabilities an entity needs to have to demonstrate it is able to perform its designated reliability functions. A competency-based reliability requirement should be framed as: *who, under what conditions (if any), shall have what capability, to achieve what particular result or*

---

<sup>2</sup> *Id.*

<sup>3</sup> “Clear line of sight” means the distance that can be seen by the average person without special instrumentation (e.g., binoculars, telescope, spyglasses, etc.) on a clear day.



*outcome to perform an action to achieve a result or outcome or to reduce a risk to the reliability of the bulk power system?*

The defense-in-depth strategy for Reliability Standards development recognizes that each requirement in a NERC Reliability Standard has a role in preventing system failures, and that these roles are complementary and reinforcing. Reliability Standards should not be viewed as a body of unrelated requirements, but rather should be viewed as part of a portfolio of requirements designed to achieve an overall defense-in-depth strategy and comport with the quality objectives of a Reliability Standard.

This standard uses a defense-in-depth approach to improve the reliability of the electric Transmission system by:

- Requiring that vegetation be managed to prevent vegetation encroachment inside the flash-over clearance (R1 and R2);
- Requiring documentation of the maintenance strategies, procedures, processes and specifications used to manage vegetation to prevent potential flash-over conditions including consideration of 1) conductor dynamics and 2) the interrelationships between vegetation growth rates, control methods and the inspection frequency (R3);
- Requiring timely notification to the appropriate control center of vegetation conditions that could cause a flash-over at any moment (R4);
- Requiring corrective actions to ensure that flash-over distances will not be violated due to work constraints such as legal injunctions (R5);
- Requiring inspections of vegetation conditions to be performed annually (R6); and
- Requiring that the annual work needed to prevent flash-over is completed (R7).

For this standard, the requirements have been developed as follows:

- Performance-based: Requirements 1 and 2
- Competency-based: Requirement 3
- Risk-based: Requirements 4, 5, 6 and 7

Requirement R3 serves as the first line of defense by ensuring that entities understand the problem they are trying to manage and have fully developed strategies and plans to manage the problem. Requirements R1, R2, and R7 serve as the second line of defense by requiring that entities carry out their plans and manage vegetation. Requirement R6, which requires inspections, may be either a part of the first line of defense (as input into the strategies and plans) or as a third line of defense (as a check of the first and second lines of defense). Requirement R4 serves as the final line of defense, as it addresses cases in which all the other lines of defense have failed.

Major outages and operational problems have resulted from interference between overgrown vegetation and transmission lines located on many types of lands and ownership situations. Adherence to the standard requirements for applicable lines on any kind of land or easement, whether they are Federal Lands, state or provincial lands, public or private lands, franchises, easements or lands owned in fee, will reduce and manage this risk. For the purpose of the standard the term “public lands” includes municipal lands, village lands, city lands, and a host of other governmental entities.

This standard addresses vegetation management along applicable overhead lines and does not apply to underground lines, submarine lines or to line sections inside an electric station boundary.

This standard focuses on transmission lines to prevent those vegetation related outages that could lead to Cascading. It is not intended to prevent customer outages due to tree contact with lower voltage distribution system lines. For example, localized customer service might be disrupted if vegetation were to make contact with a 69kV transmission line supplying power to a 12kV distribution station. However, this standard is not written to address such isolated situations which have little impact on the overall electric transmission system.

Since vegetation growth is constant and always present, unmanaged vegetation poses an increased outage risk, especially when numerous transmission lines are operating at or near their Rating. This can present a significant risk of consecutive line failures when lines are experiencing large sags thereby leading to Cascading. Once the first line fails the shift of the current to the other lines and/or the increasing system loads will lead to the second and subsequent line failures as contact to the vegetation under those lines occurs. Conversely, most other outage causes (such as trees falling into lines, lightning, animals, motor vehicles, etc.) are not an interrelated function of the shift of currents or the increasing system loading. These events are not any more likely to occur during heavy system loads than any other time. There is no cause-effect relationship which creates the probability of simultaneous occurrence of other such events. Therefore these types of events are highly unlikely to cause large-scale grid failures. Thus, this standard places the highest priority on the management of vegetation to prevent vegetation grow-ins.

## **B. Requirements and Measures**

- R1.** Each applicable Transmission Owner and applicable Generator Owner shall manage vegetation to prevent encroachments into the Minimum Vegetation Clearance Distance (MVCD) of its applicable line(s), operating within their Rating and all Rated

Electrical Operating Conditions of the types shown below<sup>4</sup> [*Violation Risk Factor: High*] [*Time Horizon: Real-time*]:

- 1.1.** An encroachment into the MVCD as shown in FAC-003-Table 2, observed in Real-time, absent a Sustained Outage,<sup>5</sup>
  - 1.2.** An encroachment due to a fall-in from inside the ROW that caused a vegetation-related Sustained Outage,<sup>6</sup>
  - 1.3.** An encroachment due to the blowing together of applicable lines and vegetation located inside the ROW that caused a vegetation-related Sustained Outage,<sup>7</sup>
  - 1.4.** An encroachment due to vegetation growth into the MVCD that caused a vegetation-related Sustained Outage.<sup>8</sup>
- M1.** Each applicable Transmission Owner and applicable Generator Owner has evidence that it managed vegetation to prevent encroachment into the MVCD as described in R1. Examples of acceptable forms of evidence may include dated attestations, dated reports containing no Sustained Outages associated with encroachment types 2 through 4 above, or records confirming no Real-time observations of any MVCD encroachments. (R1)
- R2.** [Reserved for future use]
- M2.** [Reserved for future use]
- R3.** Each applicable Transmission Owner and applicable Generator Owner shall have documented maintenance strategies or procedures or processes or specifications it uses to prevent the encroachment of vegetation into the MVCD of its applicable lines that accounts for the following: [*Violation Risk Factor: Lower*] [*Time Horizon: Long Term Planning*]:
- 3.1.** Movement of applicable line conductors under their Rating and all Rated Electrical Operating Conditions;

---

<sup>4</sup> This requirement does not apply to circumstances that are beyond the control of an applicable Transmission Owner or applicable Generator Owner subject to this Reliability Standard, including natural disasters such as earthquakes, fires, tornados, hurricanes, landslides, wind shear, fresh gale, major storms as defined either by the applicable Transmission Owner or applicable Generator Owner or an applicable regulatory body, ice storms, and floods; human or animal activity such as logging, animal severing tree, vehicle contact with tree, or installation, removal, or digging of vegetation. Nothing in this footnote should be construed to limit the Transmission Owner's or applicable Generator Owner's right to exercise its full legal rights on the ROW.

<sup>5</sup> If a later confirmation of a Fault by the applicable Transmission Owner or applicable Generator Owner shows that a vegetation encroachment within the MVCD has occurred from vegetation within the ROW, this shall be considered the equivalent of a Real-time observation.

<sup>6</sup> Multiple Sustained Outages on an individual line, if caused by the same vegetation, will be reported as one outage regardless of the actual number of outages within a 24-hour period.

<sup>7</sup> *Id.*

<sup>8</sup> *Id.*

- 3.2.** Inter-relationships between vegetation growth rates, vegetation control methods, and inspection frequency.
- M3.** The maintenance strategies or procedures or processes or specifications provided demonstrate that the applicable Transmission Owner and applicable Generator Owner can prevent encroachment into the MVCD considering the factors identified in the requirement. (R3)
- R4.** Each applicable Transmission Owner and applicable Generator Owner, without any intentional time delay, shall notify the control center holding switching authority for the associated applicable line when the applicable Transmission Owner and applicable Generator Owner has confirmed the existence of a vegetation condition that is likely to cause a Fault at any moment [*Violation Risk Factor: Medium*] [*Time Horizon: Real-time*].
- M4.** Each applicable Transmission Owner and applicable Generator Owner that has a confirmed vegetation condition likely to cause a Fault at any moment will have evidence that it notified the control center holding switching authority for the associated transmission line without any intentional time delay. Examples of evidence may include control center logs, voice recordings, switching orders, clearance orders and subsequent work orders. (R4)
- R5.** When an applicable Transmission Owner and an applicable Generator Owner are constrained from performing vegetation work on an applicable line operating within its Rating and all Rated Electrical Operating Conditions, and the constraint may lead to a vegetation encroachment into the MVCD prior to the implementation of the next annual work plan, then the applicable Transmission Owner or applicable Generator Owner shall take corrective action to ensure continued vegetation management to prevent encroachments [*Violation Risk Factor: Medium*] [*Time Horizon: Operations Planning*].
- M5.** Each applicable Transmission Owner and applicable Generator Owner has evidence of the corrective action taken for each constraint where an applicable transmission line was put at potential risk. Examples of acceptable forms of evidence may include initially-planned work orders, documentation of constraints from landowners, court orders, inspection records of increased monitoring, documentation of the de-rating of lines, revised work orders, invoices, or evidence that the line was de-energized. (R5)
- R6.** Each applicable Transmission Owner and applicable Generator Owner shall perform a Vegetation Inspection of 100% of its applicable transmission lines (measured in units of choice - circuit, pole line, line miles or kilometers, etc.) at least once per calendar

year and with no more than 18 calendar months between inspections on the same ROW<sup>9</sup> [*Violation Risk Factor: Medium*] [*Time Horizon: Operations Planning*].

- M6.** Each applicable Transmission Owner and applicable Generator Owner has evidence that it conducted Vegetation Inspections of the transmission line ROW for all applicable lines at least once per calendar year but with no more than 18 calendar months between inspections on the same ROW. Examples of acceptable forms of evidence may include completed and dated work orders, dated invoices, or dated inspection records. (R6)
- R7.** Each applicable Transmission Owner and applicable Generator Owner shall complete 100% of its annual vegetation work plan of applicable lines to ensure no vegetation encroachments occur within the MVCD. Modifications to the work plan in response to changing conditions or to findings from vegetation inspections may be made (provided they do not allow encroachment of vegetation into the MVCD) and must be documented. The percent completed calculation is based on the number of units actually completed divided by the number of units in the final amended plan (measured in units of choice - circuit, pole line, line miles or kilometers, etc.). Examples of reasons for modification to annual plan may include [*Violation Risk Factor: Medium*] [*Time Horizon: Operations Planning*]:
- 7.1.** Change in expected growth rate/environmental factors
  - 7.2.** Circumstances that are beyond the control of an applicable Transmission Owner or applicable Generator Owner<sup>10</sup>
  - 7.3.** Rescheduling work between growing seasons
  - 7.4.** Crew or contractor availability/Mutual assistance agreements
  - 7.5.** Identified unanticipated high priority work
  - 7.6.** Weather conditions/Accessibility
  - 7.7.** Permitting delays
  - 7.8.** Land ownership changes/Change in land use by the landowner
  - 7.9.** Emerging technologies
- M7.** Each applicable Transmission Owner and applicable Generator Owner has evidence that it completed its annual vegetation work plan for its applicable lines. Examples of acceptable forms of evidence may include a copy of the completed annual work plan

---

<sup>9</sup> When the applicable Transmission Owner or applicable Generator Owner is prevented from performing a Vegetation Inspection within the timeframe in R6 due to a natural disaster, the TO or GO is granted a time extension that is equivalent to the duration of the time the TO or GO was prevented from performing the Vegetation Inspection.

<sup>10</sup> Circumstances that are beyond the control of an applicable Transmission Owner or applicable Generator Owner include but are not limited to natural disasters such as earthquakes, fires, tornados, hurricanes, landslides, ice storms, floods, or major storms as defined either by the TO or GO or an applicable regulatory body.

(as finally modified), dated work orders, dated invoices, or dated inspection records.  
(R7)

## C. Compliance

### 1. Compliance Monitoring Process

#### 1.1. Compliance Enforcement Authority:

“Compliance Enforcement Authority” means NERC or the Regional Entity, or any entity as otherwise designated by an Applicable Governmental Authority, in their respective roles of monitoring and/or enforcing compliance with mandatory and enforceable Reliability Standards in their respective jurisdictions.

#### 1.2. Evidence Retention:

The following evidence retention period(s) identify the period of time an entity is required to retain specific evidence to demonstrate compliance. For instances where the evidence retention period specified below is shorter than the time since the last audit, the Compliance Enforcement Authority may ask an entity to provide other evidence to show that it was compliant for the full-time period since the last audit.

The applicable entity shall keep data or evidence to show compliance as identified below unless directed by its Compliance Enforcement Authority to retain specific evidence for a longer period of time as part of an investigation.

- The applicable Transmission Owner and applicable Generator Owner retains data or evidence to show compliance with Requirements R1, R3, R5, R6 and R7, for three calendar years.
- The applicable Transmission Owner and applicable Generator Owner retains data or evidence to show compliance with Requirement R4, Measure M4 for most recent 12 months of operator logs or most recent 3 months of voice recordings or transcripts of voice recordings, unless directed by its Compliance Enforcement Authority to retain specific evidence for a longer period of time as part of an investigation.
- If an applicable Transmission Owner or applicable Generator Owner is found non-compliant, it shall keep information related to the non-compliance until found compliant or for the time period specified above, whichever is longer.

#### 1.3. Compliance Monitoring and Enforcement Program

As defined in the NERC Rules of Procedure, “Compliance Monitoring and Enforcement Program” refers to the identification of the processes that will be used to evaluate data or information for the purpose of assessing performance or outcomes with the associated Reliability Standard.

#### 1.4. Additional Compliance Information

**Periodic Data Submittal:** The applicable Transmission Owner and applicable Generator Owner will submit a quarterly report to its Regional Entity, or the Regional Entity's designee, identifying all Sustained Outages of applicable lines operated within their Rating and all Rated Electrical Operating Conditions as determined by the applicable Transmission Owner or applicable Generator Owner to have been caused by vegetation, except as excluded in footnote 4, and including as a minimum the following:

- The name of the circuit(s), the date, time and duration of the outage; the voltage of the circuit; a description of the cause of the outage; the category associated with the Sustained Outage; other pertinent comments; and any countermeasures taken by the applicable Transmission Owner or applicable Generator Owner.

A Sustained Outage is to be categorized as one of the following:

- Category 1A — Grow-ins: Sustained Outages caused by vegetation growing into applicable lines, that are identified by the Planning Coordinator, per its Planning Assessment of the Near-Term Transmission Planning Horizon as a Facility that if lost or degraded are expected to result in instances of instability, Cascading, or uncontrolled separation that adversely impacts the reliability of the Bulk Electric System by vegetation inside and/or outside of the ROW;
- Category 1B — Grow-ins: Sustained Outages caused by vegetation growing into applicable lines, but are not identified by the Planning Coordinator, per its Planning Assessment of the Near-Term Transmission Planning Horizon as a Facility that if lost or degraded are expected to result in instances of instability, Cascading, or uncontrolled separation that adversely impacts the reliability of the Bulk Electric System for a planning event by vegetation inside and/or outside of the ROW;
- Category 2A — Fall-ins: Sustained Outages caused by vegetation falling into applicable lines that are identified by the Planning Coordinator, per its Planning Assessment of the Near-Term Transmission Planning Horizon as Facility that if lost or degraded are expected to result in instances of instability, Cascading, or uncontrolled separation that adversely impacts the reliability of the Bulk Electric System for a planning event from within the ROW;
- Category 2B — Fall-ins: Sustained Outages caused by vegetation falling into applicable lines, but are not identified by the Planning Coordinator, per its Planning Assessment of the Near-Term Transmission Planning Horizon as Facilities that if lost or degraded are expected to result in instances of instability, Cascading, or uncontrolled separation that adversely impacts the reliability of the Bulk Electric System for a planning event from within the ROW;

- Category 3 — Fall-ins: Sustained Outages caused by vegetation falling into applicable lines from outside the ROW;
- Category 4A — Blowing together: Sustained Outages caused by vegetation and applicable lines that are identified by the Planning Coordinator, per its Planning Assessment of the Near-Term Transmission Planning Horizon as a Facility that if lost or degraded are expected to result in instances of instability, Cascading, or uncontrolled separation that adversely impacts the reliability of the Bulk Electric System for a planning event blowing together from within the ROW;
- Category 4B — Blowing together: Sustained Outages caused by vegetation and applicable lines, but are not identified by the Planning Coordinator, per its Planning Assessment of the Near-Term Transmission Planning Horizon as a Facility that if lost or degraded are expected to result in instances of instability, Cascading, or uncontrolled separation that adversely impacts the reliability of the Bulk Electric System for a planning event blowing together from within the ROW.

The Regional Entity will report the outage information provided by applicable Transmission Owners and applicable Generator Owners, as per the above, quarterly to NERC, as well as any actions taken by the Regional Entity as a result of any of the reported Sustained Outages.



Violation Severity Levels (Table 1)

R #	Table 1: Violation Severity Levels (VSL)			
	Lower VSL	Moderate VSL	High VSL	Severe VSL
R1.			<p>The responsible entity failed to manage vegetation to prevent encroachment into the MVCD of a line identified in the Applicability section 4.2 and 4.3 and encroachment into the MVCD as identified in FAC-003-5-Table 2 was observed in real time absent a Sustained Outage.</p>	<p>The responsible entity failed to manage vegetation to prevent encroachment into the MVCD of a line identified in the Applicability section 4.2 and 4.3 and a vegetation-related Sustained Outage was caused by one of the following:</p> <ul style="list-style-type: none"> <li>• <i>A fall-in from inside the active transmission line ROW</i></li> <li>• <i>Blowing together of applicable lines and vegetation located inside the active transmission line ROW</i></li> <li>• <i>A grow-in</i></li> </ul>
R2.Reserved for future use				

<p><b>R3.</b></p>		<p>The responsible entity has maintenance strategies or documented procedures or processes or specifications but has not accounted for the inter-relationships between vegetation growth rates, vegetation control methods, and inspection frequency, for the responsible entity's applicable lines. (Requirement R3, Part 3.2.)</p>	<p>The responsible entity has maintenance strategies or documented procedures or processes or specifications but has not accounted for the movement of transmission line conductors under their Rating and all Rated Electrical Operating Conditions, for the responsible entity's applicable lines. (Requirement R3, Part 3.1.)</p>	<p>The responsible entity does not have any maintenance strategies or documented procedures or processes or specifications used to prevent the encroachment of vegetation into the MVCD, for the responsible entity's applicable lines.</p>
<p><b>R4.</b></p>			<p>The responsible entity experienced a confirmed vegetation threat and notified the control center holding switching authority for that applicable line, but there was intentional delay in that notification.</p>	<p>The responsible entity experienced a confirmed vegetation threat and did not notify the control center holding switching authority for that applicable line.</p>
<p><b>R5.</b></p>				<p>The responsible entity did not take corrective action when it was constrained from performing planned vegetation work where an applicable line was put at potential risk.</p>

<p><b>R6.</b></p>	<p>The responsible entity failed to inspect 5% or less of its applicable lines (measured in units of choice - circuit, pole line, line miles or kilometers, etc.)</p>	<p>The responsible entity failed to inspect more than 5% up to and including 10% of its applicable lines (measured in units of choice - circuit, pole line, line miles or kilometers, etc.).</p>	<p>The responsible entity failed to inspect more than 10% up to and including 15% of its applicable lines (measured in units of choice - circuit, pole line, line miles or kilometers, etc.).</p>	<p>The responsible entity failed to inspect more than 15% of its applicable lines (measured in units of choice - circuit, pole line, line miles or kilometers, etc.).</p>
<p><b>R7.</b></p>	<p>The responsible entity failed to complete 5% or less of its annual vegetation work plan for its applicable lines (as finally modified).</p>	<p>The responsible entity failed to complete more than 5% and up to and including 10% of its annual vegetation work plan for its applicable lines (as finally modified).</p>	<p>The responsible entity failed to complete more than 10% and up to and including 15% of its annual vegetation work plan for its applicable lines (as finally modified).</p>	<p>The responsible entity failed to complete more than 15% of its annual vegetation work plan for its applicable lines (as finally modified).</p>

**D. Regional Variances**

None.

**E. Associated Documents**

- FAC-003-4 Implementation Plan

## Version History

Version	Date	Action	Change Tracking
1	January 20, 2006	<ol style="list-style-type: none"> <li>1. Added "Standard Development Roadmap."</li> <li>2. Changed "60" to "Sixty" in section A, 5.2.</li> <li>3. Added "Proposed Effective Date: April 7, 2006" to footer.</li> <li>4. Added "Draft 3: November 17, 2005" to footer.</li> </ol>	New
1	April 4, 2007	Regulatory Approval - Effective Date	New
2	November 3, 2011	Adopted by the NERC Board of Trustees	New
2	March 21, 2013	<p>FERC Order issued approving FAC-003-2 (Order No. 777)</p> <p>FERC Order No. 777 was issued on March 21, 2013 directing NERC to "conduct or contract testing to obtain empirical data and submit a report to the Commission providing the results of the testing."<sup>11</sup></p>	Revisions
2	May 9, 2013	Board of Trustees adopted the modification of the VRF for Requirement R2 of FAC-003-2 by raising the VRF from "Medium" to "High."	Revisions
3	May 9, 2013	FAC-003-3 adopted by Board of Trustees	Revisions
3	September 19, 2013	A FERC order was issued on September 19, 2013, approving FAC-003-3. This standard became enforceable on July 1, 2014 for Transmission Owners. For Generator Owners, R3 became enforceable on January 1, 2015 and all other requirements (R1, R2, R4, R5, R6, and R7) became enforceable on January 1, 2016.	Revisions
3	November 22, 2013	Updated the VRF for R2 from "Medium" to "High" per a Final Rule issued by FERC	Revisions
3	July 30, 2014	Transferred the effective dates section from FAC-003-2 (for Transmission Owners) into FAC-003-3, per the FAC-003-3 implementation plan	Revisions

<sup>11</sup> Revisions to Reliability Standard for Transmission Vegetation Management, Order No. 777, 142 FERC ¶ 61,208 (2013)

## FAC-003-5 Transmission Vegetation Management

---

4	February 11, 2016	Adopted by Board of Trustees. Adjusted MVCD values in Table 2 for alternating current systems, consistent with findings reported in report filed on August 12, 2015 in Docket No. RM12-4-002 consistent with FERC's directive in Order No. 777, and based on empirical testing results for flashover distances between conductors and vegetation.	Revisions
4	March 9, 2016	Corrected subpart 7.10 to M7, corrected value of .07 to .7	Errata
4	April 26, 2016	FERC Letter Order approving FAC-003-4. Docket No. RD16-4-000.	
5	May 13, 2021	Adopted by Board of Trustees	Revisions under Project 2015-09

**FAC-003 — TABLE 2 — Minimum Vegetation Clearance Distances (MVCD)<sup>12</sup>  
For Alternating Current Voltages (feet)**

( AC ) Nominal System Voltage (KV)*	( AC ) Maximum System Voltage (kV) <sup>13</sup>	MVCD (feet) Over sea level up to 500 ft	MVCD feet Over 500 ft up to 1000 ft	MVCD feet Over 1000 ft up to 2000 ft	MVCD feet Over 2000 ft up to 3000 ft	MVCD feet Over 3000 ft up to 4000 ft	MVCD feet Over 4000 ft up to 5000 ft	MVCD feet Over 5000 ft up to 6000 ft	MVCD feet Over 6000 ft up to 7000 ft	MVCD feet Over 7000 ft up to 8000 ft	MVCD feet Over 8000 ft up to 9000 ft	MVCD feet Over 9000 ft up to 10000 ft	MVCD feet Over 10000 ft up to 11000 ft	MVCD feet Over 11000 ft up to 12000 ft	MVCD feet Over 12000 ft up to 13000 ft	MVCD feet Over 13000 ft up to 14000 ft	MVCD feet Over 1400 ft up to 1500 ft
765	800	11.6ft	11.7ft	11.9ft	12.1ft	12.2ft	12.4ft	12.6ft	12.8ft	13.0ft	13.1ft	13.3ft	13.5ft	13.7ft	13.9ft	14.1ft	14.3ft
500	550	7.0ft	7.1ft	7.2ft	7.4ft	7.5ft	7.6ft	7.8ft	7.9ft	8.1ft	8.2ft	8.3ft	8.5ft	8.6ft	8.8ft	8.9ft	9.1ft
345	362 <sup>14</sup>	4.3ft	4.3ft	4.4ft	4.5ft	4.6ft	4.7ft	4.8ft	4.9ft	5.0ft	5.1ft	5.2ft	5.3ft	5.4ft	5.5ft	5.6ft	5.7ft
287	302	5.2ft	5.3ft	5.4ft	5.5ft	5.6ft	5.7ft	5.8ft	5.9ft	6.1ft	6.2ft	6.3ft	6.4ft	6.5ft	6.6ft	6.8ft	6.9ft
230	242	4.0ft	4.1ft	4.2ft	4.3ft	4.3ft	4.4ft	4.5ft	4.6ft	4.7ft	4.8ft	4.9ft	5.0ft	5.1ft	5.2ft	5.3ft	5.4ft
161	169	2.7ft	2.7ft	2.8ft	2.9ft	2.9ft	3.0ft	3.0ft	3.1ft	3.2ft	3.3ft	3.3ft	3.4ft	3.5ft	3.6ft	3.7ft	3.8ft
138	145	2.3ft	2.3ft	2.4ft	2.4ft	2.5ft	2.5ft	2.6ft	2.7ft	2.7ft	2.8ft	2.8ft	2.9ft	3.0ft	3.0ft	3.1ft	3.2ft
115	121	1.9ft	1.9ft	1.9ft	2.0ft	2.0ft	2.1ft	2.1ft	2.2ft	2.2ft	2.3ft	2.3ft	2.4ft	2.5ft	2.5ft	2.6ft	2.7ft
88	100	1.5ft	1.5ft	1.6ft	1.6ft	1.7ft	1.7ft	1.8ft	1.8ft	1.8ft	1.9ft	1.9ft	2.0ft	2.0ft	2.1ft	2.2ft	2.2ft
69	72	1.1ft	1.1ft	1.1ft	1.2ft	1.2ft	1.2ft	1.2ft	1.3ft	1.3ft	1.3ft	1.4ft	1.4ft	1.4ft	1.5ft	1.6ft	1.6ft

<sup>+</sup> Table 2 – Table of MVCD values at a 1.0 gap factor (in U.S. customary units), which is located in the EPRI report filed with FERC on August 12, 2015. (The 14000-15000 foot values were subsequently provided by EPRI in an updated Table 2 on December 1, 2015, filed with the FAC-003-4 Petition at FERC)

<sup>12</sup> The distances in this Table are the minimums required to prevent Flash-over; however prudent vegetation maintenance practices dictate that substantially greater distances will be achieved at time of vegetation maintenance.

<sup>13</sup> Where applicable lines are operated at nominal voltages other than those listed, the applicable Transmission Owner or applicable Generator Owner should use the maximum system voltage to determine the appropriate clearance for that line.

<sup>14</sup> The change in transient overvoltage factors in the calculations are the driver in the decrease in MVCDs for voltages of 345 kV and above. Refer to pp.29-31 in the Supplemental Materials for additional information.

**TABLE 2 (CONT) — Minimum Vegetation Clearance Distances (MVCD)<sup>15</sup>**  
**For Alternating Current Voltages (meters)**

( AC ) Nomin al Syste m Volutag e (KV) <sup>+</sup>	( AC ) Maximum System Voltage (kV) <sup>16</sup>	MVCD meters  Over sea level up to 153 m	MVCD meters  Over 153m up to 305m	MVCD meters  Over 305m up to 610m	MVCD meters  Over 610m up to 915m	MVCD meters  Over 915m up to 1220m	MVCD meters  Over 1220m up to 1524m	MVCD meters  Over 1524m up to 1829m	MVCD meters  Over 1829m up to 2134m	MVCD meters  Over 2134m up to 2439m	MVCD meters  Over 2439m up to 2744m	MVCD meters  Over 2744m up to 3048m	MVCD meters  Over 3048m up to 3353m	MVCD meters  Over 3353m up to 3657m	MVCD meters  Over 3657m up to 3962m	MVCD meters  Over 3962 m up to 4268 m	MVCD meters  Over 4268 m up to 4572 m
765	800	3.6m	3.6m	3.6m	3.7m	3.7m	3.8m	3.8m	3.9m	4.0m	4.0m	4.1m	4.1m	4.2m	4.2m	4.3m	4.4m
500	550	2.1m	2.2m	2.2m	2.3m	2.3m	2.3m	2.4m	2.4m	2.5m	2.5m	2.5m	2.6m	2.6m	2.7m	2.7m	2.7m
345	362 <sup>17</sup>	1.3m	1.3m	1.3m	1.4m	1.4m	1.4m	1.5m	1.5m	1.5m	1.6m	1.6m	1.6m	1.6m	1.7m	1.7m	1.8m
287	302	1.6m	1.6m	1.7m	1.7m	1.7m	1.7m	1.8m	1.8m	1.9m	1.9m	1.9m	2.0m	2.0m	2.0m	2.1m	2.1m
230	242	1.2m	1.3m	1.3m	1.3m	1.3m	1.3m	1.4m	1.4m	1.4m	1.5m	1.5m	1.5m	1.6m	1.6m	1.6m	1.6m
161	169	0.8m	0.8m	0.9m	0.9m	0.9m	0.9m	0.9m	1.0m	1.0m	1.0m	1.0m	1.0m	1.1m	1.1m	1.1m	1.1m
138	145	0.7m	0.7m	0.7m	0.7m	0.7m	0.7m	0.8m	0.8m	0.8m	0.9m	0.9m	0.9m	0.9m	0.9m	1.0m	1.0m
115	121	0.6m	0.6m	0.6m	0.6m	0.6m	0.6m	0.6m	0.7m	0.7m	0.7m	0.7m	0.7m	0.8m	0.8m	0.8m	0.8m
88	100	0.4m	0.4m	0.5m	0.5m	0.5m	0.5m	0.6m	0.6m	0.6m	0.6m	0.6m	0.6m	0.6m	0.6m	0.7m	0.7m
69	72	0.3m	0.3m	0.3m	0.4m	0.4m	0.4m	0.4m	0.4m	0.4m	0.4m	0.4m	0.4m	0.4m	0.5m	0.5m	0.5m

<sup>+</sup> Table 2 – Table of MVCD values at a 1.0 gap factor (in U.S. customary units), which is located in the EPRI report filed with FERC on August 12, 2015. (The 14000-15000 foot values were subsequently provided by EPRI in an updated Table 2 on December 1, 2015, filed with the FAC-003-4 Petition at FERC)

<sup>15</sup> The distances in this Table are the minimums required to prevent Flash-over; however prudent vegetation maintenance practices dictate that substantially greater distances will be achieved at time of vegetation maintenance.

<sup>16</sup>Where applicable lines are operated at nominal voltages other than those listed, the applicable Transmission Owner or applicable Generator Owner should use the maximum system voltage to determine the appropriate clearance for that line.

<sup>17</sup> The change in transient overvoltage factors in the calculations are the driver in the decrease in MVCDs for voltages of 345 kV and above. Refer to pp.29-31 in the supplemental materials for additional information.

**TABLE 2 (CONT) — Minimum Vegetation Clearance Distances (MVCD)<sup>18</sup>**  
 For **Direct Current** Voltages feet (meters)

( DC ) Nominal Pole to Ground Voltage (kV)	MVCD meters  Over sea level up to 500 ft  (Over sea level up to 152.4 m)	MVCD meters  Over 500 ft up to 1000 ft  (Over 152.4 m up to 304.8 m)	MVCD meters  Over 1000 ft up to 2000 ft  (Over 304.8 m up to 609.6m)	MVCD meters  Over 2000 ft up to 3000 ft  (Over 609.6m up to 914.4m)	MVCD meters  Over 3000 ft up to 4000 ft  (Over 914.4m up to 1219.2m)	MVCD meters  Over 4000 ft up to 5000 ft  (Over 1219.2m up to 1524m)	MVCD meters  Over 5000 ft up to 6000 ft  (Over 1524 m up to 1828.8 m)	MVCD meters  Over 6000 ft up to 7000 ft  (Over 1828.8m up to 2133.6m)	MVCD meters  Over 7000 ft up to 8000 ft  (Over 2133.6m up to 2438.4m)	MVCD meters  Over 8000 ft up to 9000 ft  (Over 2438.4m up to 2743.2m)	MVCD meters  Over 9000 ft up to 10000 ft  (Over 2743.2m up to 3048m)	MVCD meters  Over 10000 ft up to 11000 ft  (Over 3048m up to 3352.8m)
±750	14.12ft (4.30m)	14.31ft (4.36m)	14.70ft (4.48m)	15.07ft (4.59m)	15.45ft (4.71m)	15.82ft (4.82m)	16.2ft (4.94m)	16.55ft (5.04m)	16.91ft (5.15m)	17.27ft (5.26m)	17.62ft (5.37m)	17.97ft (5.48m)
±600	10.23ft (3.12m)	10.39ft (3.17m)	10.74ft (3.26m)	11.04ft (3.36m)	11.35ft (3.46m)	11.66ft (3.55m)	11.98ft (3.65m)	12.3ft (3.75m)	12.62ft (3.85m)	12.92ft (3.94m)	13.24ft (4.04m)	13.54ft (4.13m)
±500	8.03ft (2.45m)	8.16ft (2.49m)	8.44ft (2.57m)	8.71ft (2.65m)	8.99ft (2.74m)	9.25ft (2.82m)	9.55ft (2.91m)	9.82ft (2.99m)	10.1ft (3.08m)	10.38ft (3.16m)	10.65ft (3.25m)	10.92ft (3.33m)
±400	6.07ft (1.85m)	6.18ft (1.88m)	6.41ft (1.95m)	6.63ft (2.02m)	6.86ft (2.09m)	7.09ft (2.16m)	7.33ft (2.23m)	7.56ft (2.30m)	7.80ft (2.38m)	8.03ft (2.45m)	8.27ft (2.52m)	8.51ft (2.59m)
±250	3.50ft (1.07m)	3.57ft (1.09m)	3.72ft (1.13m)	3.87ft (1.18m)	4.02ft (1.23m)	4.18ft (1.27m)	4.34ft (1.32m)	4.5ft (1.37m)	4.66ft (1.42m)	4.83ft (1.47m)	5.00ft (1.52m)	5.17ft (1.58m)

<sup>18</sup> The distances in this Table are the minimums required to prevent Flash-over; however prudent vegetation maintenance practices dictate that substantially greater distances will be achieved at time of vegetation maintenance.



## Guideline and Technical Basis

### Effective dates:

The Compliance section is standard language used in most NERC standards to cover the general effective date and covers the vast majority of situations. A special case covers effective dates for (1) lines initially becoming subject to the Standard, (2) lines changing in applicability within the standard.

The special case is needed because the Planning Coordinators or Transmission Planners may designate lines below 200 kV, per its Planning Assessment of the Near-Term Transmission Planning Horizon or its Transfer Capability Assessment as Facilities that if lost or degraded are expected to result in instances of instability, Cascading, or uncontrolled separation that adversely impacts the reliability of the Bulk Electric System for a planning event in a future Planning Year (PY). For example, studies by the Planning Coordinator in 2015 may identify a line to have that designation beginning in PY 2025, ten years after the planning study is performed. It is not intended for the Standard to be immediately applicable to, or in effect for, that line until that future PY begins. The effective date provision for such lines ensures that the line will become subject to the standard on January 1 of the PY specified with an allowance of at least 12 months for the applicable Transmission Owner or applicable Generator Owner to make the necessary preparations to achieve compliance on that line. A line operating below 200kV designated by the Planning Coordinator or Transmission Planner, per its Planning Assessment of the Near-Term Transmission Planning Horizon or its Transfer Capability Assessment (Planning Coordinator only) as Facilities that if lost or degraded are expected to result in instances of instability, Cascading, or uncontrolled separation that adversely impacts the reliability of the Bulk Electric System for a planning event may be removed from that designation due to system improvements, changes in generation, changes in loads or changes in studies and analysis of the network.

<u>Date that Planning Study is completed</u>	<u>PY the line will become an identified element</u>	<u>Date 1</u>	<u>Date 2</u>	<u>Effective Date The later of Date 1 or Date 2</u>
05/15/2011	2012	05/15/2012	01/01/2012	05/15/2012
05/15/2011	2013	05/15/2012	01/01/2013	01/01/2013
05/15/2011	2014	05/15/2012	01/01/2014	01/01/2014
05/15/2011	2021	05/15/2012	01/01/2021	01/01/2021

### Defined Terms:

#### Explanation for revising the definition of ROW:

The current NERC glossary definition of Right of Way has been modified to include Generator Owners and to address the matter set forth in Paragraph 734 of FERC Order 693. The Order pointed out that Transmission Owners may in some cases own more property or rights than are needed to reliably operate transmission lines. This definition represents a slight but significant departure from the strict legal definition of “right of way” in that this definition is based on engineering and construction considerations that establish the width of a corridor from a technical basis. The pre-2007 maintenance records are included in the current definition to allow the use of such vegetation widths if there were no engineering or construction standards that referenced the width of right of way to be maintained for vegetation on a particular line but the evidence exists in maintenance records for a width that was in fact maintained prior to this standard becoming mandatory. Such widths may be the only information available for lines that had limited or no vegetation easement rights and were typically maintained primarily to ensure public safety. This standard does not require additional easement rights to be purchased to satisfy a minimum right of way width that did not exist prior to this standard becoming mandatory.

### **Explanation for revising the definition of Vegetation Inspection:**

The current glossary definition of this NERC term was modified to include Generator Owners and to allow both maintenance inspections and vegetation inspections to be performed concurrently. This allows potential efficiencies, especially for those lines with minimal vegetation and/or slow vegetation growth rates.

### **Explanation of the derivation of the MVCD:**

The MVCD is a calculated minimum distance that is derived from the Gallet equation. This is a method of calculating a flash over distance that has been used in the design of high voltage transmission lines. Keeping vegetation away from high voltage conductors by this distance will prevent voltage flash-over to the vegetation. See the explanatory text below for Requirement R3 and associated Figure 1. Table 2 of the standard provides MVCD values for various voltages and altitudes. The table is based on empirical testing data from EPRI as requested by FERC in Order No. 777.

### **Project 2010-07.1 Adjusted MVCDs per EPRI Testing:**

In Order No. 777, FERC directed NERC to undertake testing to gather empirical data validating the appropriate gap factor used in the Gallet equation to calculate MVCDs, specifically the gap factor for the flash-over distances between conductors and vegetation. See, Order No. 777, at P 60. NERC engaged industry through a collaborative research project and contracted EPRI to complete the scope of work. In January 2014, NERC formed an advisory group to assist with developing the scope of work for the project. This team provided subject matter expertise for developing the test plan, monitoring testing, and vetting the analysis and conclusions to be submitted in a final report. The advisory team was comprised of NERC staff, arborists, and industry members with wide-ranging expertise in transmission engineering, insulation coordination, and vegetation management. The testing project commenced in April 2014 and continued through October 2014 with the final set of testing completed in May 2015. Based on these testing results conducted by EPRI, and consistent with the report filed in FERC Docket No.

RM12-4-000, the gap factor used in the Gallet equation required adjustment from 1.3 to 1.0. This resulted in increased MVCD values for all alternating current system voltages identified. The adjusted MVCD values, reflecting the 1.0 gap factor, are included in Table 2 of version 4 of FAC-003.

The air gap testing completed by EPRI per FERC Order No. 777 established that trees with large spreading canopies growing directly below energized high voltage conductors create the greatest likelihood of an air gap flash over incident and was a key driver in changing the gap factor to a more conservative value of 1.0 in version 4 of this standard.

### **Requirements R1:**

R1 is a performance-based requirements. The reliability objective or outcome to be achieved is the management of vegetation such that there are no vegetation encroachments within a minimum distance of transmission lines R1 requires each applicable Transmission Owner or applicable Generator Owner to manage vegetation to prevent encroachment within the MVCD of transmission lines. R1 is applicable to lines that are identified as an element in the Applicability section 4.2 and 4.3.

Requirements R1 states that if inadequate vegetation management allows vegetation to encroach within the MVCD distance as shown in Table 2, it is a violation of the standard. Table 2 distances are the minimum clearances that will prevent spark-over based on the Gallet equations. These requirements assume that transmission lines and their conductors are operating within their Rating. If a line conductor is intentionally or inadvertently operated beyond its Rating and Rated Electrical Operating Condition (potentially in violation of other standards), the occurrence of a clearance encroachment may occur solely due to that condition. For example, emergency actions taken by an applicable Transmission Owner or applicable Generator Owner or Reliability Coordinator to protect an Interconnection may cause excessive sagging and an outage. Another example would be ice loading beyond the line's Rating and Rated Electrical Operating Condition. Such vegetation-related encroachments and outages are not violations of this standard.

Evidence of failures to adequately manage vegetation include real-time observation of a vegetation encroachment into the MVCD (absent a Sustained Outage), or a vegetation-related encroachment resulting in a Sustained Outage due to a fall-in from inside the ROW, or a vegetation-related encroachment resulting in a Sustained Outage due to the blowing together of the lines and vegetation located inside the ROW, or a vegetation-related encroachment resulting in a Sustained Outage due to a grow-in. Faults which do not cause a Sustained outage and which are confirmed to have been caused by vegetation encroachment within the MVCD are considered the equivalent of a Real-time observation for violation severity levels.

With this approach, the VSLs for R1 are structured such that they directly correlate to the severity of a failure of an applicable Transmission Owner or applicable Generator Owner to manage vegetation and to the corresponding performance level of the Transmission Owner's vegetation program's ability to meet the objective of "preventing the risk of those vegetation related outages that could lead to Cascading." Thus violation severity increases with an applicable

Transmission Owner's or applicable Generator Owner's inability to meet this goal and its potential of leading to a Cascading event. The additional benefits of such a combination are that it simplifies the standard and clearly defines performance for compliance. A performance-based requirement of this nature will promote high quality, cost effective vegetation management programs that will deliver the overall end result of improved reliability to the system.

Multiple Sustained Outages on an individual line can be caused by the same vegetation. For example initial investigations and corrective actions may not identify and remove the actual outage cause then another outage occurs after the line is re-energized and previous high conductor temperatures return. Such events are considered to be a single vegetation-related Sustained Outage under the standard where the Sustained Outages occur within a 24 hour period.

If the applicable Transmission Owner or applicable Generator Owner has applicable lines operated at nominal voltage levels not listed in Table 2, then the applicable TO or applicable GO should use the next largest clearance distance based on the next highest nominal voltage in the table to determine an acceptable distance.

### **Requirement R3:**

R3 is a competency based requirement concerned with the maintenance strategies, procedures, processes, or specifications, an applicable Transmission Owner or applicable Generator Owner uses for vegetation management.

An adequate transmission vegetation management program formally establishes the approach the applicable Transmission Owner or applicable Generator Owner uses to plan and perform vegetation work to prevent transmission Sustained Outages and minimize risk to the transmission system. The approach provides the basis for evaluating the intent, allocation of appropriate resources, and the competency of the applicable Transmission Owner or applicable Generator Owner in managing vegetation. There are many acceptable approaches to manage vegetation and avoid Sustained Outages. However, the applicable Transmission Owner or applicable Generator Owner must be able to show the documentation of its approach and how it conducts work to maintain clearances.

An example of one approach commonly used by industry is ANSI Standard A300, part 7. However, regardless of the approach a utility uses to manage vegetation, any approach an applicable Transmission Owner or applicable Generator Owner chooses to use will generally contain the following elements:

- 1. the maintenance strategy used (such as minimum vegetation-to-conductor distance or maximum vegetation height) to ensure that MVCD clearances are never violated*
- 2. the work methods that the applicable Transmission Owner or applicable Generator Owner uses to control vegetation*
- 3. a stated Vegetation Inspection frequency*

4. an annual work plan

The conductor's position in space at any point in time is continuously changing in reaction to a number of different loading variables. Changes in vertical and horizontal conductor positioning are the result of thermal and physical loads applied to the line. Thermal loading is a function of line current and the combination of numerous variables influencing ambient heat dissipation including wind velocity/direction, ambient air temperature and precipitation. Physical loading applied to the conductor affects sag and sway by combining physical factors such as ice and wind loading. The movement of the transmission line conductor and the MVCD is illustrated in Figure 1 below.

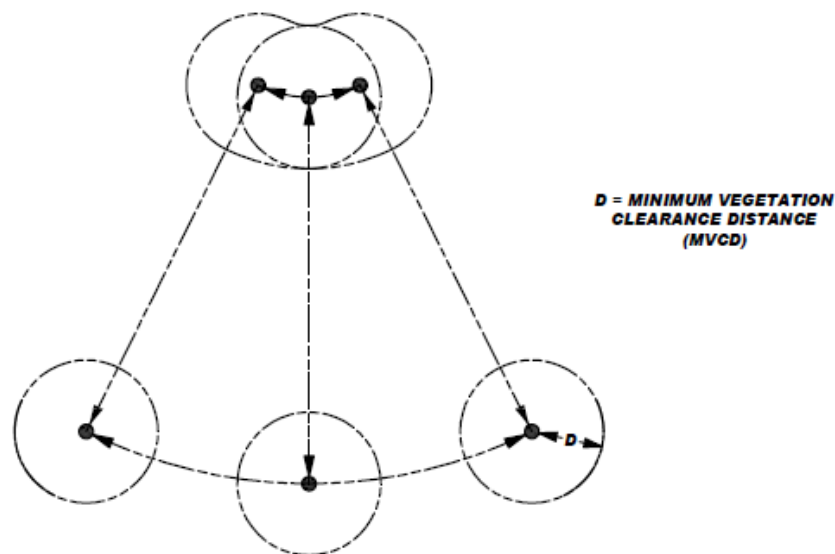


Figure 1

A cross-section view of a single conductor at a given point along the span is shown with six possible conductor positions due to movement resulting from thermal and mechanical loading.

**Requirement R4:**

R4 is a risk-based requirement. It focuses on preventative actions to be taken by the applicable Transmission Owner or applicable Generator Owner for the mitigation of Fault risk when a vegetation threat is confirmed. R4 involves the notification of potentially threatening vegetation conditions, without any intentional delay, to the control center holding switching authority for that specific transmission line. Examples of acceptable unintentional delays may include communication system problems (for example, cellular service or two-way radio disabled), crews located in remote field locations with no communication access, delays due to severe weather, etc.

Confirmation is key that a threat actually exists due to vegetation. This confirmation could be in the form of an applicable Transmission Owner or applicable Generator Owner employee who personally identifies such a threat in the field. Confirmation could also be made by sending out an employee to evaluate a situation reported by a landowner.

Vegetation-related conditions that warrant a response include vegetation that is near or encroaching into the MVCD (a grow-in issue) or vegetation that could fall into the transmission conductor (a fall-in issue). A knowledgeable verification of the risk would include an assessment of the possible sag or movement of the conductor while operating between no-load conditions and its rating.

The applicable Transmission Owner or applicable Generator Owner has the responsibility to ensure the proper communication between field personnel and the control center to allow the control center to take the appropriate action until or as the vegetation threat is relieved. Appropriate actions may include a temporary reduction in the line loading, switching the line out of service, or other preparatory actions in recognition of the increased risk of outage on that circuit. The notification of the threat should be communicated in terms of minutes or hours as opposed to a longer time frame for corrective action plans (see R5).

All potential grow-in or fall-in vegetation-related conditions will not necessarily cause a Fault at any moment. For example, some applicable Transmission Owners or applicable Generator Owners may have a danger tree identification program that identifies trees for removal with the potential to fall near the line. These trees would not require notification to the control center unless they pose an immediate fall-in threat.

### **Requirement R5:**

R5 is a risk-based requirement. It focuses upon preventative actions to be taken by the applicable Transmission Owner or applicable Generator Owner for the mitigation of Sustained Outage risk when temporarily constrained from performing vegetation maintenance. The intent of this requirement is to deal with situations that prevent the applicable Transmission Owner or applicable Generator Owner from performing planned vegetation management work and, as a result, have the potential to put the transmission line at risk. Constraints to performing vegetation maintenance work as planned could result from legal injunctions filed by property owners, the discovery of easement stipulations which limit the applicable Transmission Owner's or applicable Generator Owner's rights, or other circumstances.

This requirement is not intended to address situations where the transmission line is not at potential risk and the work event can be rescheduled or re-planned using an alternate work methodology. For example, a land owner may prevent the planned use of herbicides to control incompatible vegetation outside of the MVCD, but agree to the use of mechanical clearing. In this case the applicable Transmission Owner or applicable Generator Owner is not under any immediate time constraint for achieving the management objective, can easily reschedule work using an alternate approach, and therefore does not need to take interim corrective action.

However, in situations where transmission line reliability is potentially at risk due to a constraint, the applicable Transmission Owner or applicable Generator Owner is required to take an interim corrective action to mitigate the potential risk to the transmission line. A wide range of actions can be taken to address various situations. General considerations include:

- Identifying locations where the applicable Transmission Owner or applicable Generator Owner is constrained from performing planned vegetation maintenance work which potentially leaves the transmission line at risk.
- Developing the specific action to mitigate any potential risk associated with not performing the vegetation maintenance work as planned.
- Documenting and tracking the specific action taken for the location.
- In developing the specific action to mitigate the potential risk to the transmission line the applicable Transmission Owner or applicable Generator Owner could consider location specific measures such as modifying the inspection and/or maintenance intervals. Where a legal constraint would not allow any vegetation work, the interim corrective action could include limiting the loading on the transmission line.
- The applicable Transmission Owner or applicable Generator Owner should document and track the specific corrective action taken at each location. This location may be indicated as one span, one tree or a combination of spans on one property where the constraint is considered to be temporary.

### **Requirement R6:**

R6 is a risk-based requirement. This requirement sets a minimum time period for completing Vegetation Inspections. The provision that Vegetation Inspections can be performed in conjunction with general line inspections facilitates a Transmission Owner's ability to meet this requirement. However, the applicable Transmission Owner or applicable Generator Owner may determine that more frequent vegetation specific inspections are needed to maintain reliability levels, based on factors such as anticipated growth rates of the local vegetation, length of the local growing season, limited ROW width, and local rainfall. Therefore it is expected that some transmission lines may be designated with a higher frequency of inspections.

The VSLs for Requirement R6 have levels ranked by the failure to inspect a percentage of the applicable lines to be inspected. To calculate the appropriate VSL the applicable Transmission Owner or applicable Generator Owner may choose units such as: circuit, pole line, line miles or kilometers, etc.

For example, when an applicable Transmission Owner or applicable Generator Owner operates 2,000 miles of applicable transmission lines this applicable Transmission Owner or applicable Generator Owner will be responsible for inspecting all the 2,000 miles of lines at least once during the calendar year. If one of the included lines was 100 miles long, and if it was not inspected during the year, then the amount failed to inspect would be  $100/2000 = 0.05$  or 5%. The "Low VSL" for R6 would apply in this example.

### Requirement R7:

R7 is a risk-based requirement. The applicable Transmission Owner or applicable Generator Owner is required to complete its annual work plan for vegetation management to accomplish the purpose of this standard. Modifications to the work plan in response to changing conditions or to findings from vegetation inspections may be made and documented provided they do not put the transmission system at risk. The annual work plan requirement is not intended to necessarily require a “span-by-span”, or even a “line-by-line” detailed description of all work to be performed. It is only intended to require that the applicable Transmission Owner or applicable Generator Owner provide evidence of annual planning and execution of a vegetation management maintenance approach which successfully prevents encroachment of vegetation into the MVCD.

When an applicable Transmission Owner or applicable Generator Owner identifies 1,000 miles of applicable transmission lines to be completed in the applicable Transmission Owner’s or applicable Generator Owner’s annual plan, the applicable Transmission Owner or applicable Generator Owner will be responsible completing those identified miles. If an applicable Transmission Owner or applicable Generator Owner makes a modification to the annual plan that does not put the transmission system at risk of an encroachment the annual plan may be modified. If 100 miles of the annual plan is deferred until next year the calculation to determine what percentage was completed for the current year would be:  $1000 - 100$  (deferred miles) = 900 modified annual plan, or  $900 / 900 = 100\%$  completed annual miles. If an applicable Transmission Owner or applicable Generator Owner only completed 875 of the total 1000 miles with no acceptable documentation for modification of the annual plan the calculation for failure to complete the annual plan would be:  $1000 - 875 = 125$  miles failed to complete then,  $125$  miles (not completed) /  $1000$  total annual plan miles =  $12.5\%$  failed to complete.

The ability to modify the work plan allows the applicable Transmission Owner or applicable Generator Owner to change priorities or treatment methodologies during the year as conditions or situations dictate. For example recent line inspections may identify unanticipated high priority work, weather conditions (drought) could make herbicide application ineffective during the plan year, or a major storm could require redirecting local resources away from planned maintenance. This situation may also include complying with mutual assistance agreements by moving resources off the applicable Transmission Owner’s or applicable Generator Owner’s system to work on another system. Any of these examples could result in acceptable deferrals or additions to the annual work plan provided that they do not put the transmission system at risk of a vegetation encroachment.

In general, the vegetation management maintenance approach should use the full extent of the applicable Transmission Owner’s or applicable Generator Owner’s easement, fee simple and other legal rights allowed. A comprehensive approach that exercises the full extent of legal rights on the ROW is superior to incremental management because in the long term it reduces the overall potential for encroachments, and it ensures that future planned work and future planned inspection cycles are sufficient.



When developing the annual work plan the applicable Transmission Owner or applicable Generator Owner should allow time for procedural requirements to obtain permits to work on federal, state, provincial, public, tribal lands. In some cases the lead time for obtaining permits may necessitate preparing work plans more than a year prior to work start dates. Applicable Transmission Owners or applicable Generator Owners may also need to consider those special landowner requirements as documented in easement instruments.

This requirement sets the expectation that the work identified in the annual work plan will be completed as planned. Therefore, deferrals or relevant changes to the annual plan shall be documented. Depending on the planning and documentation format used by the applicable Transmission Owner or applicable Generator Owner, evidence of successful annual work plan execution could consist of signed-off work orders, signed contracts, printouts from work management systems, spreadsheets of planned versus completed work, timesheets, work inspection reports, or paid invoices. Other evidence may include photographs, and walk-through reports.

### **Notes:**

The SDT determined that the use of IEEE 516-2003 in version 1 of FAC-003 was a misapplication. The SDT consulted specialists who advised that the Gallet equation would be a technically justified method. The explanation of why the Gallet approach is more appropriate is explained in the paragraphs below.

The drafting team sought a method of establishing minimum clearance distances that uses realistic weather conditions and realistic maximum transient over-voltages factors for in-service transmission lines.

The SDT considered several factors when looking at changes to the minimum vegetation to conductor distances in FAC-003-1:

- avoid the problem associated with referring to tables in another standard (IEEE-516-2003)
- transmission lines operate in non-laboratory environments (wet conditions)
- transient over-voltage factors are lower for in-service transmission lines than for inadvertently re-energized transmission lines with trapped charges.

FAC-003-1 used the minimum air insulation distance (MAID) without tools formula provided in IEEE 516-2003 to determine the minimum distance between a transmission line conductor and vegetation. The equations and methods provided in IEEE 516 were developed by an IEEE Task Force in 1968 from test data provided by thirteen independent laboratories. The distances provided in IEEE 516 Tables 5 and 7 are based on the withstand voltage of a dry rod-rod air gap, or in other words, dry laboratory conditions. Consequently, the validity of using these distances in an outside environment application has been questioned.

FAC-003-1 allowed Transmission Owners to use either Table 5 or Table 7 to establish the minimum clearance distances. Table 7 could be used if the Transmission Owner knew the

maximum transient over-voltage factor for its system. Otherwise, Table 5 would have to be used. Table 5 represented minimum air insulation distances under the worst possible case for transient over-voltage factors. These worst case transient over-voltage factors were as follows: 3.5 for voltages up to 362 kV phase to phase; 3.0 for 500 - 550 kV phase to phase; and 2.5 for 765 to 800 kV phase to phase. These worst case over-voltage factors were also a cause for concern in this particular application of the distances.

In general, the worst case transient over-voltages occur on a transmission line that is inadvertently re-energized immediately after the line is de-energized and a trapped charge is still present. The intent of FAC-003 is to keep a transmission line that is in service from becoming de-energized (i.e. tripped out) due to spark-over from the line conductor to nearby vegetation. Thus, the worst case transient overvoltage assumptions are not appropriate for this application. Rather, the appropriate over voltage values are those that occur only while the line is energized.

Typical values of transient over-voltages of in-service lines are not readily available in the literature because they are negligible compared with the maximums. A conservative value for the maximum transient over-voltage that can occur anywhere along the length of an in-service ac line was approximately 2.0 per unit. This value was a conservative estimate of the transient over-voltage that is created at the point of application (e.g. a substation) by switching a capacitor bank without pre-insertion devices (e.g. closing resistors). At voltage levels where capacitor banks are not very common (e.g. Maximum System Voltage of 362 kV), the maximum transient over-voltage of an in-service ac line are created by fault initiation on adjacent ac lines and shunt reactor bank switching. These transient voltages are usually 1.5 per unit or less.

Even though these transient over-voltages will not be experienced at locations remote from the bus at which they are created, in order to be conservative, it is assumed that all nearby ac lines are subjected to this same level of over-voltage. Thus, a maximum transient over-voltage factor of 2.0 per unit for transmission lines operated at 302 kV and below was considered to be a realistic maximum in this application. Likewise, for ac transmission lines operated at Maximum System Voltages of 362 kV and above a transient over-voltage factor of 1.4 per unit was considered a realistic maximum.

The Gallet equations are an accepted method for insulation coordination in tower design. These equations are used for computing the required strike distances for proper transmission line insulation coordination. They were developed for both wet and dry applications and can be used with any value of transient over-voltage factor. The Gallet equation also can take into account various air gap geometries. This approach was used to design the first 500 kV and 765 kV lines in North America.

If one compares the MAID using the IEEE 516-2003 Table 7 (table D.5 for English values) with the critical spark-over distances computed using the Gallet wet equations, for each of the nominal voltage classes and identical transient over-voltage factors, the Gallet equations yield a more conservative (larger) minimum distance value.

Distances calculated from either the IEEE 516 (dry) formulas or the Gallet “wet” formulas are not vastly different when the same transient overvoltage factors are used; the “wet” equations will consistently produce slightly larger distances than the IEEE 516 equations when the same transient overvoltage is used. While the IEEE 516 equations were only developed for dry conditions the Gallet equations have provisions to calculate spark-over distances for both wet and dry conditions.

Since no empirical data for spark over distances to live vegetation existed at the time version 3 was developed, the SDT chose a proven method that has been used in other EHV applications. The Gallet equations relevance to wet conditions and the selection of a Transient Overvoltage Factor that is consistent with the absence of trapped charges on an in-service transmission line make this methodology a better choice.

The following table is an example of the comparison of distances derived from IEEE 516 and the Gallet equations.

**Comparison of spark-over distances computed using Gallet wet equations vs.  
IEEE 516-2003 MAID distances**

( AC ) Nom System Voltage (kV)	( AC ) Max System Voltage (kV)	Transient Over-voltage Factor (T)	Clearance (ft.) Gallet (wet) @ Alt. 3000 feet	Table 7 (Table D.5 for feet) IEEE 516-2003 MAID (ft) @ Alt. 3000 feet
765	800	2.0	14.36	13.95
500	550	2.4	11.0	10.07
345	362	3.0	8.55	7.47
230	242	3.0	5.28	4.2
115	121	3.0	2.46	2.1

### **Rationale:**

During development of this standard, text boxes were embedded within the standard to explain the rationale for various parts of the standard. Upon BOT approval, the text from the rationale text boxes was moved to this section.

### **Rationale for Applicability (section 4.2.4):**

The areas excluded in 4.2.4 were excluded based on comments from industry for reasons summarized as follows:

- 1) There is a very low risk from vegetation in this area. Based on an informal survey, no TOs reported such an event.
- 2) Substations, switchyards, and stations have many inspection and maintenance activities that are necessary for reliability. Those existing process manage the threat. As such, the formal steps in this standard are not well suited for this environment.
- 3) Specifically addressing the areas where the standard does and does not apply makes the standard clearer.

### **Rationale for Applicability (section 4.3):**

Within the text of NERC Reliability Standard FAC-003-3, “transmission line(s)” and “applicable line(s)” can also refer to the generation Facilities as referenced in 4.3 and its subsections.

### **Rationale for R1:**

Lines with the highest significance to reliability are covered in R1; all other lines are covered in R2.

Rationale for the types of failure to manage vegetation which are listed in order of increasing degrees of severity in non-compliant performance as it relates to a failure of an applicable Transmission Owner's or applicable Generator Owner's vegetation maintenance program:

1. This management failure is found by routine inspection or Fault event investigation, and is normally symptomatic of unusual conditions in an otherwise sound program.
2. This management failure occurs when the height and location of a side tree within the ROW is not adequately addressed by the program.
3. This management failure occurs when side growth is not adequately addressed and may be indicative of an unsound program.
4. This management failure is usually indicative of a program that is not addressing the most fundamental dynamic of vegetation management, (i.e. a grow-in under the line). If this type of failure is pervasive on multiple lines, it provides a mechanism for a Cascade.

### **Rationale for R3:**

The documentation provides a basis for evaluating the competency of the applicable Transmission Owner's or applicable Generator Owner's vegetation program. There may be many acceptable approaches to maintain clearances. Any approach must demonstrate that the

applicable Transmission Owner or applicable Generator Owner avoids vegetation-to-wire conflicts under all Ratings and all Rated Electrical Operating Conditions.

### **Rationale for R4:**

This is to ensure expeditious communication between the applicable Transmission Owner or applicable Generator Owner and the control center when a critical situation is confirmed.

### **Rationale for R5:**

Legal actions and other events may occur which result in constraints that prevent the applicable Transmission Owner or applicable Generator Owner from performing planned vegetation maintenance work.

In cases where the transmission line is put at potential risk due to constraints, the intent is for the applicable Transmission Owner and applicable Generator Owner to put interim measures in place, rather than do nothing.

The corrective action process is not intended to address situations where a planned work methodology cannot be performed but an alternate work methodology can be used.

### **Rationale for R6:**

Inspections are used by applicable Transmission Owners and applicable Generator Owners to assess the condition of the entire ROW. The information from the assessment can be used to determine risk, determine future work and evaluate recently-completed work. This requirement sets a minimum Vegetation Inspection frequency of once per calendar year but with no more than 18 months between inspections on the same ROW. Based upon average growth rates across North America and on common utility practice, this minimum frequency is reasonable. Transmission Owners should consider local and environmental factors that could warrant more frequent inspections.

### **Rationale for R7:**

This requirement sets the expectation that the work identified in the annual work plan will be completed as planned. It allows modifications to the planned work for changing conditions, taking into consideration anticipated growth of vegetation and all other environmental factors, provided that those modifications do not put the transmission system at risk of a vegetation encroachment.

## A. Introduction

1. **Title:** Transmission Vegetation Management
2. **Number:** FAC-003-~~54~~
3. **Purpose:** To maintain a reliable electric transmission system by using a defense-in-depth strategy to manage vegetation located on transmission rights of way (ROW) and minimize encroachments from vegetation located adjacent to the ROW, thus preventing the risk of those vegetation-related outages that could lead to Cascading.
4. **Applicability:**
  - 4.1. **Functional Entities:**
    - 4.1.1. Applicable Transmission Owners
      - 4.1.1.1. Transmission Owners that own Transmission Facilities defined in 4.2.
    - 4.1.2. Applicable Generator Owners
      - 4.1.2.1. Generator Owners that own generation Facilities defined in 4.3.
  - 4.2. **Transmission Facilities:** Defined below (referred to as “applicable lines”), including but not limited to those that cross lands owned by federal<sup>1</sup>, state, provincial, public, private, or tribal entities:
    - 4.2.1. Each overhead transmission line operated at 200kV or higher.
    - 4.2.2. Each overhead transmission line operated below 200kV, identified by the Planning Coordinator or Transmission Planner, per its Planning Assessment of the Near-Term Transmission Planning Horizon as a Facility that if lost or degraded are expected to result in instances of instability, Cascading, or uncontrolled separation that adversely impacts the reliability of the Bulk Electric System for a planning event. identified as an element of an IROL under NERC Standard FAC-014 by the Planning Coordinator.
    - 4.2.3. Each overhead transmission line operated below 200 kV identified as an element of a Major Western Electricity Coordinating Council (WECC) Transfer Path in the Bulk Electric System by WECC.
    - 4.2.4. Each overhead transmission line identified above (4.2.1. through 4.2.3.) located outside the fenced area of the switchyard, station or substation and any portion of the span of the transmission line that is crossing the substation fence.

---

<sup>1</sup> EPAAct 2005 section 1211c: “Access approvals by Federal agencies.”

**4.3. Generation Facilities:** Defined below (referred to as “applicable lines”), including but not limited to those that cross lands owned by federal<sup>2</sup>, state, provincial, public, private, or tribal entities:

**4.3.1.** Overhead transmission lines that (1) extend greater than one mile or 1.609 kilometers beyond the fenced area of the generating station switchyard to the point of interconnection with a Transmission Owner’s Facility or (2) do not have a clear line of sight<sup>3</sup> from the generating station switchyard fence to the point of interconnection with a Transmission Owner’s Facility and are:

**4.3.1.1.** Operated at 200kV or higher; or

**4.3.1.2.** Operated below 200kV and are identified by the Planning Coordinator or Transmission Planner, per its Planning Assessment of the Near-Term Transmission Planning Horizon as a Facility that if lost or degraded are expected to result in instances of instability, Cascading, or uncontrolled separation that adversely impacts the reliability of the Bulk Electric System for a planning event identified as an IROL under NERC Standard FAC-014 by the Planning Coordinator; or

**4.3.1.3.** Operated below 200 kV identified as an element of a Major WECC Transfer Path in the Bulk Electric System by WECC.

**5. Effective Date:** See Implementation Plan

**6. Background:** This standard uses three types of requirements to provide layers of protection to prevent vegetation related outages that could lead to Cascading:

- a) Performance-based defines a particular reliability objective or outcome to be achieved. In its simplest form, a results-based requirement has four components: *who, under what conditions (if any), shall perform what action, to achieve what particular bulk power system performance result or outcome?*
- b) Risk-based preventive requirements to reduce the risks of failure to acceptable tolerance levels. A risk-based reliability requirement should be framed as: *who, under what conditions (if any), shall perform what action, to achieve what particular result or outcome that reduces a stated risk to the reliability of the bulk power system?*
- c) Competency-based defines a minimum set of capabilities an entity needs to have to demonstrate it is able to perform its designated reliability functions. A competency-based reliability requirement should be framed as: *who, under what*

---

<sup>2</sup> *Id.*

<sup>3</sup> “Clear line of sight” means the distance that can be seen by the average person without special instrumentation (e.g., binoculars, telescope, spyglasses, etc.) on a clear day.

*conditions (if any), shall have what capability, to achieve what particular result or outcome to perform an action to achieve a result or outcome or to reduce a risk to the reliability of the bulk power system?*

The defense-in-depth strategy for Reliability Standards development recognizes that each requirement in a NERC Reliability Standard has a role in preventing system failures, and that these roles are complementary and reinforcing. Reliability Standards should not be viewed as a body of unrelated requirements, but rather should be viewed as part of a portfolio of requirements designed to achieve an overall defense-in-depth strategy and comport with the quality objectives of a Reliability Standard.

This standard uses a defense-in-depth approach to improve the reliability of the electric Transmission system by:

- Requiring that vegetation be managed to prevent vegetation encroachment inside the flash-over clearance (R1 and R2);
- Requiring documentation of the maintenance strategies, procedures, processes and specifications used to manage vegetation to prevent potential flash-over conditions including consideration of 1) conductor dynamics and 2) the interrelationships between vegetation growth rates, control methods and the inspection frequency (R3);
- Requiring timely notification to the appropriate control center of vegetation conditions that could cause a flash-over at any moment (R4);
- Requiring corrective actions to ensure that flash-over distances will not be violated due to work constrains such as legal injunctions (R5);
- Requiring inspections of vegetation conditions to be performed annually (R6); and
- Requiring that the annual work needed to prevent flash-over is completed (R7).

For this standard, the requirements have been developed as follows:

- Performance-based: Requirements 1 and 2
- Competency-based: Requirement 3
- Risk-based: Requirements 4, 5, 6 and 7

Requirement R3 serves as the first line of defense by ensuring that entities understand the problem they are trying to manage and have fully developed strategies and plans to manage the problem. Requirements R1, R2, and R7 serve as the second line of defense by requiring that entities carry out their plans and manage vegetation.

Requirement R6, which requires inspections, may be either a part of the first line of defense (as input into the strategies and plans) or as a third line of defense (as a check of the first and second lines of defense). Requirement R4 serves as the final line of defense, as it addresses cases in which all the other lines of defense have failed.



Major outages and operational problems have resulted from interference between overgrown vegetation and transmission lines located on many types of lands and ownership situations. Adherence to the standard requirements for applicable lines on any kind of land or easement, whether they are Federal Lands, state or provincial lands, public or private lands, franchises, easements or lands owned in fee, will reduce and manage this risk. For the purpose of the standard the term “public lands” includes municipal lands, village lands, city lands, and a host of other governmental entities.

This standard addresses vegetation management along applicable overhead lines and does not apply to underground lines, submarine lines or to line sections inside an electric station boundary.

This standard focuses on transmission lines to prevent those vegetation related outages that could lead to Cascading. It is not intended to prevent customer outages due to tree contact with lower voltage distribution system lines. For example, localized customer service might be disrupted if vegetation were to make contact with a 69kV transmission line supplying power to a 12kV distribution station. However, this standard is not written to address such isolated situations which have little impact on the overall electric transmission system.

Since vegetation growth is constant and always present, unmanaged vegetation poses an increased outage risk, especially when numerous transmission lines are operating at or near their Rating. This can present a significant risk of consecutive line failures when lines are experiencing large sags thereby leading to Cascading. Once the first line fails the shift of the current to the other lines and/or the increasing system loads will lead to the second and subsequent line failures as contact to the vegetation under those lines occurs. Conversely, most other outage causes (such as trees falling into lines, lightning, animals, motor vehicles, etc.) are not an interrelated function of the shift of currents or the increasing system loading. These events are not any more likely to occur during heavy system loads than any other time. There is no cause-effect relationship which creates the probability of simultaneous occurrence of other such events. Therefore these types of events are highly unlikely to cause large-scale grid failures. Thus, this standard places the highest priority on the management of vegetation to prevent vegetation grow-ins.

## B. Requirements and Measures

- R1. Each applicable Transmission Owner and applicable Generator Owner shall manage vegetation to prevent encroachments into the Minimum Vegetation Clearance Distance (MVCD) of its applicable line(s), ~~which are either an element of an IROL, or an element of a Major WECC Transfer Path;~~ operating within their Rating and all

Rated Electrical Operating Conditions of the types shown below<sup>4</sup> [*Violation Risk Factor: High*] [*Time Horizon: Real-time*]:

- 1.1. An encroachment into the MVCD as shown in FAC-003-Table 2, observed in Real-time, absent a Sustained Outage,<sup>5</sup>
  - 1.2. An encroachment due to a fall-in from inside the ROW that caused a vegetation-related Sustained Outage,<sup>6</sup>
  - 1.3. An encroachment due to the blowing together of applicable lines and vegetation located inside the ROW that caused a vegetation-related Sustained Outage,<sup>7</sup>
  - 1.4. An encroachment due to vegetation growth into the MVCD that caused a vegetation-related Sustained Outage.<sup>8</sup>
- M1. Each applicable Transmission Owner and applicable Generator Owner has evidence that it managed vegetation to prevent encroachment into the MVCD as described in R1. Examples of acceptable forms of evidence may include dated attestations, dated reports containing no Sustained Outages associated with encroachment types 2 through 4 above, or records confirming no Real-time observations of any MVCD encroachments. (R1)
- R2. ~~[Reserved for future use] Each applicable Transmission Owner and applicable Generator Owner shall manage vegetation to prevent encroachments into the MVCD of its applicable line(s) which are not either an element of an IROL, or an element of a Major WECC Transfer Path; operating within its Rating and all Rated Electrical Operating Conditions of the types shown below<sup>9</sup> [*Violation Risk Factor: High*] [*Time Horizon: Real-time*]:~~
- ~~2.1. An encroachment into the MVCD, observed in Real-time, absent a Sustained Outage,<sup>10</sup>~~

---

<sup>4</sup> This requirement does not apply to circumstances that are beyond the control of an applicable Transmission Owner or applicable Generator Owner subject to this ~~R~~eliability ~~S~~tandard, including natural disasters such as earthquakes, fires, tornados, hurricanes, landslides, wind shear, fresh gale, major storms as defined either by the applicable Transmission Owner or applicable Generator Owner or an applicable regulatory body, ice storms, and floods; human or animal activity such as logging, animal severing tree, vehicle contact with tree, or installation, removal, or digging of vegetation. Nothing in this footnote should be construed to limit the Transmission Owner's or applicable Generator Owner's right to exercise its full legal rights on the ROW.

<sup>5</sup> If a later confirmation of a Fault by the applicable Transmission Owner or applicable Generator Owner shows that a vegetation encroachment within the MVCD has occurred from vegetation within the ROW, this shall be considered the equivalent of a Real-time observation.

<sup>6</sup> Multiple Sustained Outages on an individual line, if caused by the same vegetation, will be reported as one outage regardless of the actual number of outages within a 24-hour period.

<sup>7</sup> *Id.*

<sup>8</sup> *Id.*

<sup>9</sup> ~~See footnote 4.~~

<sup>10</sup> ~~See footnote 5.~~

<sup>11</sup> ~~See footnote 6.~~

~~2.2. An encroachment due to a fall in from inside the ROW that caused a vegetation-related Sustained Outage,<sup>11</sup>~~

~~2.3. An encroachment due to the blowing together of applicable lines and vegetation located inside the ROW that caused a vegetation related Sustained Outage,<sup>12</sup>~~

~~2.4. An encroachment due to vegetation growth into the line MVCD that caused a vegetation related Sustained Outage.<sup>13</sup>~~

~~M2. [Reserved for future use] Each applicable Transmission Owner and applicable Generator Owner has evidence that it managed vegetation to prevent encroachment into the MVCD as described in R2. Examples of acceptable forms of evidence may include dated attestations, dated reports containing no Sustained Outages associated with encroachment types 2 through 4 above, or records confirming no Real-time observations of any MVCD encroachments. (R2)~~

**R3.** Each applicable Transmission Owner and applicable Generator Owner shall have documented maintenance strategies or procedures or processes or specifications it uses to prevent the encroachment of vegetation into the MVCD of its applicable lines that accounts for the following: *[Violation Risk Factor: Lower] [Time Horizon: Long Term Planning]*:

**3.1.** Movement of applicable line conductors under their Rating and all Rated Electrical Operating Conditions;

**3.2.** Inter-relationships between vegetation growth rates, vegetation control methods, and inspection frequency.

**M3.** The maintenance strategies or procedures or processes or specifications provided demonstrate that the applicable Transmission Owner and applicable Generator Owner can prevent encroachment into the MVCD considering the factors identified in the requirement. (R3)

**R4.** Each applicable Transmission Owner and applicable Generator Owner, without any intentional time delay, shall notify the control center holding switching authority for the associated applicable line when the applicable Transmission Owner and applicable Generator Owner has confirmed the existence of a vegetation condition that is likely to cause a Fault at any moment *[Violation Risk Factor: Medium] [Time Horizon: Real-time]*.

**M4.** Each applicable Transmission Owner and applicable Generator Owner that has a confirmed vegetation condition likely to cause a Fault at any moment will have evidence that it notified the control center holding switching authority for the associated transmission line without any intentional time delay. Examples of evidence may include control center logs, voice recordings, switching orders, clearance orders and subsequent work orders. (R4)

~~<sup>12</sup>-Id.~~

~~13-14~~

**R7.R5.** When an applicable Transmission Owner and an applicable Generator Owner are constrained from performing vegetation work on an applicable line operating within its Rating and all Rated Electrical Operating Conditions, and the constraint may lead to a vegetation encroachment into the MVCD prior to the implementation of the next annual work plan, then the applicable Transmission Owner or applicable Generator Owner shall take corrective action to ensure continued vegetation management to prevent encroachments [*Violation Risk Factor: Medium*] [*Time Horizon: Operations Planning*].

**M5.** Each applicable Transmission Owner and applicable Generator Owner has evidence of the corrective action taken for each constraint where an applicable transmission line was put at potential risk. Examples of acceptable forms of evidence may include initially-planned work orders, documentation of constraints from landowners, court orders, inspection records of increased monitoring, documentation of the de-rating of lines, revised work orders, invoices, or evidence that the line was de-energized. (R5)

**R8.R6.** Each applicable Transmission Owner and applicable Generator Owner shall perform a Vegetation Inspection of 100% of its applicable transmission lines (measured in units of choice - circuit, pole line, line miles or kilometers, etc.) at least once per calendar year and with no more than 18 calendar months between inspections on the same ROW<sup>9</sup> [*Violation Risk Factor: Medium*] [*Time Horizon: Operations Planning*].

**M6.** Each applicable Transmission Owner and applicable Generator Owner has evidence that it conducted Vegetation Inspections of the transmission line ROW for all applicable lines at least once per calendar year but with no more than 18 calendar months between inspections on the same ROW. Examples of acceptable forms of evidence may include completed and dated work orders, dated invoices, or dated inspection records. (R6)

**R9.R7.** Each applicable Transmission Owner and applicable Generator Owner shall complete 100% of its annual vegetation work plan of applicable lines to ensure no vegetation encroachments occur within the MVCD. Modifications to the work plan in response to changing conditions or to findings from vegetation inspections may be made (provided they do not allow encroachment of vegetation into the MVCD) and must be documented. The percent completed calculation is based on the number of units actually completed divided by the number of units in the final amended plan (measured in units of choice - circuit, pole line, line miles or kilometers, etc.).

---

<sup>9</sup> When the applicable Transmission Owner or applicable Generator Owner is prevented from performing a Vegetation Inspection within the timeframe in R6 due to a natural disaster, the TO or GO is granted a time extension that is equivalent to the duration of the time the TO or GO was prevented from performing the Vegetation Inspection.

Examples of reasons for modification to annual plan may include [*Violation Risk Factor: Medium*] [*Time Horizon: Operations Planning*]:

- 7.1. Change in expected growth rate/environmental factors
  - 7.2. Circumstances that are beyond the control of an applicable Transmission Owner or applicable Generator Owner<sup>10</sup>
  - 7.3. Rescheduling work between growing seasons
  - 7.4. Crew or contractor availability/Mutual assistance agreements
  - 7.5. Identified unanticipated high priority work
  - 7.6. Weather conditions/Accessibility
  - 7.7. Permitting delays
  - 7.8. Land ownership changes/Change in land use by the landowner
  - 7.9. Emerging technologies
- M7. Each applicable Transmission Owner and applicable Generator Owner has evidence that it completed its annual vegetation work plan for its applicable lines. Examples of acceptable forms of evidence may include a copy of the completed annual work plan (as finally modified), dated work orders, dated invoices, or dated inspection records. (R7)

## C. Compliance

### 1. Compliance Monitoring Process

#### 1.1. Compliance Enforcement Authority:

“Compliance Enforcement Authority” means NERC or the Regional Entity, or any entity as otherwise designated by an Applicable Governmental Authority, in their respective roles of monitoring and/or enforcing compliance with mandatory and enforceable Reliability Standards in their respective jurisdictions.

#### 1.2. Evidence Retention:

The following evidence retention period(s) identify the period of time an entity is required to retain specific evidence to demonstrate compliance. For instances where the evidence retention period specified below is shorter than the time since the last audit, the Compliance Enforcement Authority may ask an entity to provide other evidence to show that it was compliant for the full-time period since the last audit.

---

<sup>10</sup> Circumstances that are beyond the control of an applicable Transmission Owner or applicable Generator Owner include but are not limited to natural disasters such as earthquakes, fires, tornados, hurricanes, landslides, ice storms, floods, or major storms as defined either by the TO or GO or an applicable regulatory body.

The applicable entity shall keep data or evidence to show compliance as identified below unless directed by its Compliance Enforcement Authority to retain specific evidence for a longer period of time as part of an investigation.

- The applicable Transmission Owner and applicable Generator Owner retains data or evidence to show compliance with Requirements R1, ~~R2~~, R3, R5, R6 and R7, for three calendar years.
- The applicable Transmission Owner and applicable Generator Owner retains data or evidence to show compliance with Requirement R4, Measure M4 for most recent 12 months of operator logs or most recent 3 months of voice recordings or transcripts of voice recordings, unless directed by its Compliance Enforcement Authority to retain specific evidence for a longer period of time as part of an investigation.
- If an applicable Transmission Owner or applicable Generator Owner is found non-compliant, it shall keep information related to the non-compliance until found compliant or for the time period specified above, whichever is longer.

### 1.3. Compliance Monitoring and Enforcement Program

As defined in the NERC Rules of Procedure, “Compliance Monitoring and Enforcement Program” refers to the identification of the processes that will be used to evaluate data or information for the purpose of assessing performance or outcomes with the associated Reliability Standard.

### 1.4. Additional Compliance Information

**Periodic Data Submittal:** The applicable Transmission Owner and applicable Generator Owner will submit a quarterly report to its Regional Entity, or the Regional Entity’s designee, identifying all Sustained Outages of applicable lines operated within their Rating and all Rated Electrical Operating Conditions as determined by the applicable Transmission Owner or applicable Generator Owner to have been caused by vegetation, except as excluded in footnote ~~24~~, and including as a minimum the following:

- The name of the circuit(s), the date, time and duration of the outage; the voltage of the circuit; a description of the cause of the outage; the category associated with the Sustained Outage; other pertinent comments; and any countermeasures taken by the applicable Transmission Owner or applicable Generator Owner.

A Sustained Outage is to be categorized as one of the following:

- Category 1A — Grow-ins: Sustained Outages caused by vegetation growing into applicable lines, that are identified by the Planning Coordinator, per its Planning Assessment of the Near-Term Transmission Planning Horizon as a Facility that if lost or degraded are expected to result in instances of instability, Cascading, or uncontrolled separation that adversely impacts the

reliability of the Bulk Electric System as an element of an IROL or Major WECC Transfer Path, by vegetation inside and/or outside of the ROW;

- Category 1B — Grow-ins: Sustained Outages caused by vegetation growing into applicable lines, but are not identified by the Planning Coordinator, per its Planning Assessment of the Near-Term Transmission Planning Horizon as a Facility that if lost or degraded are expected to result in instances of instability, Cascading, or uncontrolled separation that adversely impacts the reliability of the Bulk Electric System for a planning event as an element of an IROL or Major WECC Transfer Path, by vegetation inside and/or outside of the ROW;
- Category 2A — Fall-ins: Sustained Outages caused by vegetation falling into applicable lines that are identified by the Planning Coordinator, per its Planning Assessment of the Near-Term Transmission Planning Horizon as Facility that if lost or degraded are expected to result in instances of instability, Cascading, or uncontrolled separation that adversely impacts the reliability of the Bulk Electric System for a planning event as an element of an IROL or Major WECC Transfer Path, from within the ROW;
- Category 2B — Fall-ins: Sustained Outages caused by vegetation falling into applicable lines, but are not identified by the Planning Coordinator, per its Planning Assessment of the Near-Term Transmission Planning Horizon as Facilities that if lost or degraded are expected to result in instances of instability, Cascading, or uncontrolled separation that adversely impacts the reliability of the Bulk Electric System for a planning event as an element of an IROL or Major WECC Transfer Path, from within the ROW;
- Category 3 — Fall-ins: Sustained Outages caused by vegetation falling into applicable lines from outside the ROW;
- Category 4A — Blowing together: Sustained Outages caused by vegetation and applicable lines that are identified by the Planning Coordinator, per its Planning Assessment of the Near-Term Transmission Planning Horizon as a Facility that if lost or degraded are expected to result in instances of instability, Cascading, or uncontrolled separation that adversely impacts the reliability of the Bulk Electric System for a planning event as an element of an IROL or Major WECC Transfer Path, blowing together from within the ROW;
- Category 4B — Blowing together: Sustained Outages caused by vegetation and applicable lines, but are not identified by the Planning Coordinator, per its Planning Assessment of the Near-Term Transmission Planning Horizon as a Facility that if lost or degraded are expected to result in instances of instability, Cascading, or uncontrolled separation that adversely impacts the reliability of the Bulk Electric System for a planning event as an element of

~~an IROL or Major WECC Transfer Path~~, blowing together from within the ROW.

The Regional Entity will report the outage information provided by applicable Transmission Owners and applicable Generator Owners, as per the above, quarterly to NERC, as well as any actions taken by the Regional Entity as a result of any of the reported Sustained Outages.



Violation Severity Levels (Table 1)

R #	Table 1: Violation Severity Levels (VSL)			
	Lower VSL	Moderate VSL	High VSL	Severe VSL
R1.			<p>The responsible entity failed to manage vegetation to prevent encroachment into the MVCD of a line identified <u>in the Applicability section 4.2 and 4.3 by the Planning Coordinator, per its Planning Assessment of the Near-Term Transmission Planning Horizon or its Transfer Capability Assessment (Planning Coordinator only) as Facilities that if lost or degraded are expected to result in instances of instability, Cascading, or uncontrolled separation as an element of an IROL or Major WECC transfer path</u> and encroachment into the MVCD as identified in FAC-003-45-Table 2 was observed in real time</p>	<p>The responsible entity failed to manage vegetation to prevent encroachment into the MVCD of a line identified <u>in the Applicability section 4.2 and 4.3 by the Planning Coordinator, per its Planning Assessment of the Near-Term Transmission Planning Horizon or its Transfer Capability Assessment (Planning Coordinator only) as Facilities that if lost or degraded are expected to result in instances of instability, Cascading, or uncontrolled separation as an element of an IROL or Major WECC transfer path</u> and a vegetation-related Sustained Outage was caused by one of the following:</p>

			absent a Sustained Outage.	<ul style="list-style-type: none"> <li>• <i>A fall-in from inside the active transmission line ROW</i></li> <li>• <i>Blowing together of applicable lines and vegetation located inside the active transmission line ROW</i></li> <li>• <i>A grow-in</i></li> </ul>
<u>R2.Reserved for future use</u>			The responsible entity failed to manage vegetation to prevent encroachment into the MVCD of a line not identified as an element of an IROL or Major WECC transfer path and encroachment into the MVCD as identified in FAC-003-4 Table 2 was observed in real time absent a Sustained Outage.	<p>The responsible entity failed to manage vegetation to prevent encroachment into the MVCD of a line not identified as an element of an IROL or Major WECC transfer path and a vegetation-related Sustained Outage was caused by one of the following:</p> <ul style="list-style-type: none"> <li><i>A fall-in from inside the active transmission line ROW</i></li> <li><i>Blowing together of applicable lines and vegetation located inside the active transmission line ROW</i></li> </ul>

				<i>A-grow-in</i>
<b>R3.</b>		The responsible entity has maintenance strategies or documented procedures or processes or specifications but has not accounted for the inter-relationships between vegetation growth rates, vegetation control methods, and inspection frequency, for the responsible entity's applicable lines. (Requirement R3, Part 3.2.)	The responsible entity has maintenance strategies or documented procedures or processes or specifications but has not accounted for the movement of transmission line conductors under their Rating and all Rated Electrical Operating Conditions, for the responsible entity's applicable lines. (Requirement R3, Part 3.1.)	The responsible entity does not have any maintenance strategies or documented procedures or processes or specifications used to prevent the encroachment of vegetation into the MVCD, for the responsible entity's applicable lines.
<b>R4.</b>			The responsible entity experienced a confirmed vegetation threat and notified the control center holding switching authority for that applicable line, but there was intentional delay in that notification.	The responsible entity experienced a confirmed vegetation threat and did not notify the control center holding switching authority for that applicable line.
<b>R5.</b>				The responsible entity did not take corrective action when it was constrained from performing planned

				vegetation work where an applicable line was put at potential risk.
<b>R6.</b>	The responsible entity failed to inspect 5% or less of its applicable lines (measured in units of choice - circuit, pole line, line miles or kilometers, etc.)	The responsible entity failed to inspect more than 5% up to and including 10% of its applicable lines (measured in units of choice - circuit, pole line, line miles or kilometers, etc.).	The responsible entity failed to inspect more than 10% up to and including 15% of its applicable lines (measured in units of choice - circuit, pole line, line miles or kilometers, etc.).	The responsible entity failed to inspect more than 15% of its applicable lines (measured in units of choice - circuit, pole line, line miles or kilometers, etc.).
<b>R7.</b>	The responsible entity failed to complete 5% or less of its annual vegetation work plan for its applicable lines (as finally modified).	The responsible entity failed to complete more than 5% and up to and including 10% of its annual vegetation work plan for its applicable lines (as finally modified).	The responsible entity failed to complete more than 10% and up to and including 15% of its annual vegetation work plan for its applicable lines (as finally modified).	The responsible entity failed to complete more than 15% of its annual vegetation work plan for its applicable lines (as finally modified).

### D. Regional Variances

None.

### E. Associated Documents

- [FAC-003-4 Implementation Plan](#)

## Version History

Version	Date	Action	Change Tracking
1	January 20, 2006	<ol style="list-style-type: none"> <li>1. Added "Standard Development Roadmap."</li> <li>2. Changed "60" to "Sixty" in section A, 5.2.</li> <li>3. Added "Proposed Effective Date: April 7, 2006" to footer.</li> <li>4. Added "Draft 3: November 17, 2005" to footer.</li> </ol>	New
1	April 4, 2007	Regulatory Approval - Effective Date	New
2	November 3, 2011	Adopted by the NERC Board of Trustees	New
2	March 21, 2013	<p>FERC Order issued approving FAC-003-2 (Order No. 777)</p> <p>FERC Order No. 777 was issued on March 21, 2013 directing NERC to "conduct or contract testing to obtain empirical data and submit a report to the Commission providing the results of the testing."<sup>11</sup></p>	Revisions
2	May 9, 2013	Board of Trustees adopted the modification of the VRF for Requirement R2 of FAC-003-2 by raising the VRF from "Medium" to "High."	Revisions
3	May 9, 2013	FAC-003-3 adopted by Board of Trustees	Revisions
3	September 19, 2013	A FERC order was issued on September 19, 2013, approving FAC-003-3. This standard became enforceable on July 1, 2014 for Transmission Owners. For Generator Owners, R3 became enforceable on January 1, 2015 and all other requirements (R1, R2, R4, R5, R6, and R7) became enforceable on January 1, 2016.	Revisions
3	November 22, 2013	Updated the VRF for R2 from "Medium" to "High" per a Final Rule issued by FERC	Revisions
3	July 30, 2014	Transferred the effective dates section from FAC-003-2 (for Transmission Owners) into FAC-003-3, per the FAC-003-3 implementation plan	Revisions

<sup>11</sup> Revisions to Reliability Standard for Transmission Vegetation Management, Order No. 777, 142 FERC ¶ 61,208 (2013)

4	February 11, 2016	Adopted by Board of Trustees. Adjusted MVCD values in Table 2 for alternating current systems, consistent with findings reported in report filed on August 12, 2015 in Docket No. RM12-4-002 consistent with FERC's directive in Order No. 777, and based on empirical testing results for flashover distances between conductors and vegetation.	Revisions
4	March 9, 2016	Corrected subpart 7.10 to M7, corrected value of .07 to .7	Errata
4	April 26, 2016	FERC Letter Order approving FAC-003-4. Docket No. RD16-4-000.	
5	May 13, 2021	Adopted by Board of Trustees	Revisions under Project 2015-09

**FAC-003 — TABLE 2 — Minimum Vegetation Clearance Distances (MVCD)<sup>12</sup>  
For Alternating Current Voltages (feet)**

( AC ) Nominal System Voltage (KV)*	( AC ) Maximum System Voltage (kV) <sup>13</sup>	MVCD (feet) Over sea level up to 500 ft	MVCD feet Over 500 ft up to 1000 ft	MVCD feet Over 1000 ft up to 2000 ft	MVCD feet Over 2000 ft up to 3000 ft	MVCD feet Over 3000 ft up to 4000 ft	MVCD feet Over 4000 ft up to 5000 ft	MVCD feet Over 5000 ft up to 6000 ft	MVCD feet Over 6000 ft up to 7000 ft	MVCD feet Over 7000 ft up to 8000 ft	MVCD feet Over 8000 ft up to 9000 ft	MVCD feet Over 9000 ft up to 10000 ft	MVCD feet Over 10000 ft up to 11000 ft	MVCD feet Over 11000 ft up to 12000 ft	MVCD feet Over 12000 ft up to 13000 ft	MVCD feet Over 13000 ft up to 14000 ft	MVCD feet Over 1400 ft up to 1500 ft
765	800	11.6ft	11.7ft	11.9ft	12.1ft	12.2ft	12.4ft	12.6ft	12.8ft	13.0ft	13.1ft	13.3ft	13.5ft	13.7ft	13.9ft	14.1ft	14.3ft
500	550	7.0ft	7.1ft	7.2ft	7.4ft	7.5ft	7.6ft	7.8ft	7.9ft	8.1ft	8.2ft	8.3ft	8.5ft	8.6ft	8.8ft	8.9ft	9.1ft
345	362 <sup>14</sup>	4.3ft	4.3ft	4.4ft	4.5ft	4.6ft	4.7ft	4.8ft	4.9ft	5.0ft	5.1ft	5.2ft	5.3ft	5.4ft	5.5ft	5.6ft	5.7ft
287	302	5.2ft	5.3ft	5.4ft	5.5ft	5.6ft	5.7ft	5.8ft	5.9ft	6.1ft	6.2ft	6.3ft	6.4ft	6.5ft	6.6ft	6.8ft	6.9ft
230	242	4.0ft	4.1ft	4.2ft	4.3ft	4.3ft	4.4ft	4.5ft	4.6ft	4.7ft	4.8ft	4.9ft	5.0ft	5.1ft	5.2ft	5.3ft	5.4ft
161*	169	2.7ft	2.7ft	2.8ft	2.9ft	2.9ft	3.0ft	3.0ft	3.1ft	3.2ft	3.3ft	3.3ft	3.4ft	3.5ft	3.6ft	3.7ft	3.8ft
138*	145	2.3ft	2.3ft	2.4ft	2.4ft	2.5ft	2.5ft	2.6ft	2.7ft	2.7ft	2.8ft	2.8ft	2.9ft	3.0ft	3.0ft	3.1ft	3.2ft
115*	121	1.9ft	1.9ft	1.9ft	2.0ft	2.0ft	2.1ft	2.1ft	2.2ft	2.2ft	2.3ft	2.3ft	2.4ft	2.5ft	2.5ft	2.6ft	2.7ft
88*	100	1.5ft	1.5ft	1.6ft	1.6ft	1.7ft	1.7ft	1.8ft	1.8ft	1.8ft	1.9ft	1.9ft	2.0ft	2.0ft	2.1ft	2.2ft	2.2ft
69*	72	1.1ft	1.1ft	1.1ft	1.2ft	1.2ft	1.2ft	1.2ft	1.3ft	1.3ft	1.3ft	1.4ft	1.4ft	1.4ft	1.5ft	1.6ft	1.6ft

\*— Such lines are applicable to this standard only if PC has determined such per FAC-014 (refer to the Applicability Section above)

<sup>12</sup> The distances in this Table are the minimums required to prevent Flash-over; however prudent vegetation maintenance practices dictate that substantially greater distances will be achieved at time of vegetation maintenance.

<sup>13</sup> Where applicable lines are operated at nominal voltages other than those listed, the applicable Transmission Owner or applicable Generator Owner should use the maximum system voltage to determine the appropriate clearance for that line.

<sup>14</sup> The change in transient overvoltage factors in the calculations are the driver in the decrease in MVCDs for voltages of 345 kV and above. Refer to pp.29-31 in the Supplemental Materials for additional information.

+ Table 2 – Table of MVCD values at a 1.0 gap factor (in U.S. customary units), which is located in the EPRI report filed with FERC on August 12, 2015. (The 14000-15000 foot values were subsequently provided by EPRI in an updated Table 2 on December 1, 2015, filed with the FAC-003-4 Petition at FERC)

**TABLE 2 (CONT) — Minimum Vegetation Clearance Distances (MVCD)<sup>15</sup>**  
**For Alternating Current Voltages (meters)**

( AC ) Nomin al Syste m Volutag e (kV) <sup>+</sup>	( AC ) Maximum System Voltage (kV) <sup>16</sup>	MVCD meters  Over sea level up to 153 m	MVCD meters  Over 153m up to 305m	MVCD meters  Over 305m up to 610m	MVCD meters  Over 610m up to 915m	MVCD meters  Over 915m up to 1220m	MVCD meters  Over 1220m up to 1524m	MVCD meters  Over 1524m up to 1829m	MVCD meters  Over 1829m up to 2134m	MVCD meters  Over 2134m up to 2439m	MVCD meters  Over 2439m up to 2744m	MVCD meters  Over 2744m up to 3048m	MVCD meters  Over 3048m up to 3353m	MVCD meters  Over 3353m up to 3657m	MVCD meters  Over 3657m up to 3962m	MVCD meters  Over 3962 m up to 4268 m	MVCD meters  Over 4268 m up to 4572 m
765	800	3.6m	3.6m	3.6m	3.7m	3.7m	3.8m	3.8m	3.9m	4.0m	4.0m	4.1m	4.1m	4.2m	4.2m	4.3m	4.4m
500	550	2.1m	2.2m	2.2m	2.3m	2.3m	2.3m	2.4m	2.4m	2.5m	2.5m	2.5m	2.6m	2.6m	2.7m	2.7m	2.7m
345	362 <sup>17</sup>	1.3m	1.3m	1.3m	1.4m	1.4m	1.4m	1.5m	1.5m	1.5m	1.6m	1.6m	1.6m	1.6m	1.7m	1.7m	1.8m
287	302	1.6m	1.6m	1.7m	1.7m	1.7m	1.7m	1.8m	1.8m	1.9m	1.9m	1.9m	2.0m	2.0m	2.0m	2.1m	2.1m
230	242	1.2m	1.3m	1.3m	1.3m	1.3m	1.3m	1.4m	1.4m	1.4m	1.5m	1.5m	1.5m	1.6m	1.6m	1.6m	1.6m
161*	169	0.8m	0.8m	0.9m	0.9m	0.9m	0.9m	0.9m	1.0m	1.0m	1.0m	1.0m	1.0m	1.1m	1.1m	1.1m	1.1m
138*	145	0.7m	0.7m	0.7m	0.7m	0.7m	0.7m	0.8m	0.8m	0.8m	0.9m	0.9m	0.9m	0.9m	0.9m	1.0m	1.0m
115*	121	0.6m	0.6m	0.6m	0.6m	0.6m	0.6m	0.6m	0.7m	0.7m	0.7m	0.7m	0.7m	0.8m	0.8m	0.8m	0.8m
88*	100	0.4m	0.4m	0.5m	0.5m	0.5m	0.5m	0.6m	0.6m	0.6m	0.6m	0.6m	0.6m	0.6m	0.6m	0.7m	0.7m
69*	72	0.3m	0.3m	0.3m	0.4m	0.4m	0.4m	0.4m	0.4m	0.4m	0.4m	0.4m	0.4m	0.4m	0.5m	0.5m	0.5m

\*— Such lines are applicable to this standard only if PC has determined such per FAC-014 (refer to the Applicability Section above)

<sup>15</sup> The distances in this Table are the minimums required to prevent Flash-over; however prudent vegetation maintenance practices dictate that substantially greater distances will be achieved at time of vegetation maintenance.

<sup>16</sup>Where applicable lines are operated at nominal voltages other than those listed, the applicable Transmission Owner or applicable Generator Owner should use the maximum system voltage to determine the appropriate clearance for that line.

<sup>17</sup> The change in transient overvoltage factors in the calculations are the driver in the decrease in MVCDs for voltages of 345 kV and above. Refer to pp.29-31 in the supplemental materials for additional information.



+ Table 2 – Table of MVCD values at a 1.0 gap factor (in U.S. customary units), which is located in the EPRI report filed with FERC on August 12, 2015. (The 14000-15000 foot values were subsequently provided by EPRI in an updated Table 2 on December 1, 2015, filed with the FAC-003-4 Petition at FERC)

**TABLE 2 (CONT) — Minimum Vegetation Clearance Distances (MVCD)<sup>18</sup>**  
 For Direct Current Voltages feet (meters)

( DC ) Nominal Pole to Ground Voltage (kV)	MVCD meters  Over sea level up to 500 ft  (Over sea level up to 152.4 m)	MVCD meters  Over 500 ft up to 1000 ft  (Over 152.4 m up to 304.8 m)	MVCD meters  Over 1000 ft up to 2000 ft  (Over 304.8 m up to 609.6m)	MVCD meters  Over 2000 ft up to 3000 ft  (Over 609.6m up to 914.4m)	MVCD meters  Over 3000 ft up to 4000 ft  (Over 914.4m up to 1219.2m)	MVCD meters  Over 4000 ft up to 5000 ft  (Over 1219.2m up to 1524m)	MVCD meters  Over 5000 ft up to 6000 ft  (Over 1524 m up to 1828.8 m)	MVCD meters  Over 6000 ft up to 7000 ft  (Over 1828.8m up to 2133.6m)	MVCD meters  Over 7000 ft up to 8000 ft  (Over 2133.6m up to 2438.4m)	MVCD meters  Over 8000 ft up to 9000 ft  (Over 2438.4m up to 2743.2m)	MVCD meters  Over 9000 ft up to 10000 ft  (Over 2743.2m up to 3048m)	MVCD meters  Over 10000 ft up to 11000 ft  (Over 3048m up to 3352.8m)
±750	14.12ft (4.30m)	14.31ft (4.36m)	14.70ft (4.48m)	15.07ft (4.59m)	15.45ft (4.71m)	15.82ft (4.82m)	16.2ft (4.94m)	16.55ft (5.04m)	16.91ft (5.15m)	17.27ft (5.26m)	17.62ft (5.37m)	17.97ft (5.48m)
±600	10.23ft (3.12m)	10.39ft (3.17m)	10.74ft (3.26m)	11.04ft (3.36m)	11.35ft (3.46m)	11.66ft (3.55m)	11.98ft (3.65m)	12.3ft (3.75m)	12.62ft (3.85m)	12.92ft (3.94m)	13.24ft (4.04m)	13.54ft (4.13m)
±500	8.03ft (2.45m)	8.16ft (2.49m)	8.44ft (2.57m)	8.71ft (2.65m)	8.99ft (2.74m)	9.25ft (2.82m)	9.55ft (2.91m)	9.82ft (2.99m)	10.1ft (3.08m)	10.38ft (3.16m)	10.65ft (3.25m)	10.92ft (3.33m)
±400	6.07ft (1.85m)	6.18ft (1.88m)	6.41ft (1.95m)	6.63ft (2.02m)	6.86ft (2.09m)	7.09ft (2.16m)	7.33ft (2.23m)	7.56ft (2.30m)	7.80ft (2.38m)	8.03ft (2.45m)	8.27ft (2.52m)	8.51ft (2.59m)
±250	3.50ft (1.07m)	3.57ft (1.09m)	3.72ft (1.13m)	3.87ft (1.18m)	4.02ft (1.23m)	4.18ft (1.27m)	4.34ft (1.32m)	4.5ft (1.37m)	4.66ft (1.42m)	4.83ft (1.47m)	5.00ft (1.52m)	5.17ft (1.58m)

<sup>18</sup> The distances in this Table are the minimums required to prevent Flash-over; however prudent vegetation maintenance practices dictate that substantially greater distances will be achieved at time of vegetation maintenance.

## Guideline and Technical Basis

### Effective dates:

The Compliance section is standard language used in most NERC standards to cover the general effective date and covers the vast majority of situations. A special case covers effective dates for (1) lines initially becoming subject to the Standard, (2) lines changing in applicability within the standard.

The special case is needed because the Planning Coordinators or Transmission Planners may designate lines below 200 kV-, per its Planning Assessment of the Near-Term Transmission Planning Horizon or its Transfer Capability Assessment as Facilities that if lost or degraded are expected to result in instances of instability, Cascading, or uncontrolled separation that adversely impacts the reliability of the Bulk Electric System for a planning event, to become elements of an IROL or Major WECC Transfer Path in a future Planning Year (PY). For example, studies by the Planning Coordinator in 2015 may identify a line to have that designation beginning in PY 2025, ten years after the planning study is performed. It is not intended for the Standard to be immediately applicable to, or in effect for, that line until that future PY begins. The effective date provision for such lines ensures that the line will become subject to the standard on January 1 of the PY specified with an allowance of at least 12 months for the applicable Transmission Owner or applicable Generator Owner to make the necessary preparations to achieve compliance on that line. A line operating below 200kV designated by the Planning Coordinator or Transmission Planner, per its Planning Assessment of the Near-Term Transmission Planning Horizon or its Transfer Capability Assessment (Planning Coordinator only) as Facilities that if lost or degraded are expected to result in instances of instability, Cascading, or uncontrolled separation that adversely impacts the reliability of the Bulk Electric System for a planning event as an element of an IROL or Major WECC Transfer Path may be removed from that designation due to system improvements, changes in generation, changes in loads or changes in studies and analysis of the network.

<u>Date that Planning Study is completed</u>	<u>PY the line will become an IROL identified element</u>	<u>Effective Date</u>		
		<u>Date 1</u>	<u>Date 2</u>	<u>The later of Date 1 or Date 2</u>
05/15/2011	2012	05/15/2012	01/01/2012	05/15/2012
05/15/2011	2013	05/15/2012	01/01/2013	01/01/2013
05/15/2011	2014	05/15/2012	01/01/2014	01/01/2014
05/15/2011	2021	05/15/2012	01/01/2021	01/01/2021

### Defined Terms:

#### **Explanation for revising the definition of ROW:**

The current NERC glossary definition of Right of Way has been modified to include Generator Owners and to address the matter set forth in Paragraph 734 of FERC Order 693. The Order pointed out that Transmission Owners may in some cases own more property or rights than are needed to reliably operate transmission lines. This definition represents a slight but significant departure from the strict legal definition of “right of way” in that this definition is based on engineering and construction considerations that establish the width of a corridor from a technical basis. The pre-2007 maintenance records are included in the current definition to allow the use of such vegetation widths if there were no engineering or construction standards that referenced the width of right of way to be maintained for vegetation on a particular line but the evidence exists in maintenance records for a width that was in fact maintained prior to this standard becoming mandatory. Such widths may be the only information available for lines that had limited or no vegetation easement rights and were typically maintained primarily to ensure public safety. This standard does not require additional easement rights to be purchased to satisfy a minimum right of way width that did not exist prior to this standard becoming mandatory.

#### **Explanation for revising the definition of Vegetation Inspection:**

The current glossary definition of this NERC term was modified to include Generator Owners and to allow both maintenance inspections and vegetation inspections to be performed concurrently. This allows potential efficiencies, especially for those lines with minimal vegetation and/or slow vegetation growth rates.

#### **Explanation of the derivation of the MVCD:**

The MVCD is a calculated minimum distance that is derived from the Gallet equation. This is a method of calculating a flash over distance that has been used in the design of high voltage transmission lines. Keeping vegetation away from high voltage conductors by this distance will prevent voltage flash-over to the vegetation. See the explanatory text below for Requirement R3 and associated Figure 1. Table 2 of the Sstandard provides MVCD values for various voltages and altitudes. The table is based on empirical testing data from EPRI as requested by FERC in Order No. 777.

#### **Project 2010-07.1 Adjusted MVCDs per EPRI Testing:**

In Order No. 777, FERC directed NERC to undertake testing to gather empirical data validating the appropriate gap factor used in the Gallet equation to calculate MVCDs, specifically the gap factor for the flash-over distances between conductors and vegetation. See, Order No. 777, at P 60. NERC engaged industry through a collaborative research project and contracted EPRI to complete the scope of work. In January 2014, NERC formed an advisory group to assist with developing the scope of work for the project. This team provided subject matter expertise for developing the test plan, monitoring testing, and vetting the analysis and conclusions to be submitted in a final report. The advisory team was comprised of NERC staff, arborists, and industry members with wide-ranging expertise in transmission engineering, insulation

coordination, and vegetation management. The testing project commenced in April 2014 and continued through October 2014 with the final set of testing completed in May 2015. Based on these testing results conducted by EPRI, and consistent with the report filed in FERC Docket No. RM12-4-000, the gap factor used in the Gallet equation required adjustment from 1.3 to 1.0. This resulted in increased MVCD values for all alternating current system voltages identified. The adjusted MVCD values, reflecting the 1.0 gap factor, are included in Table 2 of version 4 of FAC-003.

The air gap testing completed by EPRI per FERC Order No. 777 established that trees with large spreading canopies growing directly below energized high voltage conductors create the greatest likelihood of an air gap flash over incident and was a key driver in changing the gap factor to a more conservative value of 1.0 in version 4 of this standard.

### **Requirements R1 and R2:**

R1 ~~and R2 are~~ a performance-based requirements. The reliability objective or outcome to be achieved is the management of vegetation such that there are no vegetation encroachments within a minimum distance of transmission lines. ~~Content wise, R1 and R2 are the same requirements; however, they apply to different Facilities. Both R1 and R2 require~~ s each applicable Transmission Owner or applicable Generator Owner to manage vegetation to prevent encroachment within the MVCD of transmission lines. R1 is applicable to lines that are identified as an element ~~of an IROL or Major WECC Transfer in the Applicability section 4.2 and 4.3 Path by the Planning Coordinator, per its Planning Assessment of the Near Term Transmission Planning Horizon or its Transfer Capability Assessment (Planning Coordinator only) as Facilities that if lost or degraded are expected to result in instances of instability, Cascading, or uncontrolled separation.~~ R2 is applicable to all other lines that are not identified as an element ~~by the Planning Coordinator, per its Planning Assessment of the Near Term Transmission Planning Horizon or its Transfer Capability Assessment (Planning Coordinator only) as Facilities that if lost or degraded are expected to result in instances of instability, Cascading, or uncontrolled separation pursuant to FAC 015-1 Requirement R4~~ elements of IROLs, and not elements of Major WECC Transfer Paths.

~~The separation of applicability (between R1 and R2) recognizes that inadequate vegetation management for an applicable line has been identified as an element by the Planning Coordinator, per its Planning Assessment of the Near Term Transmission Planning Horizon or its Transfer Capability Assessment (Planning Coordinator only) as Facilities that if lost or degraded are expected to result in instances of instability, Cascading, or uncontrolled separation that is an element of an IROL or a Major WECC Transfer Path is a greater risk to the interconnected electric transmission system than applicable lines that are not elements of IROLs or Major WECC Transfer Paths have not been identified as such. Applicable lines that are not elements of IROLs or Major WECC Transfer Paths have not been identified as such do require effective vegetation management, but these lines are comparatively less operationally significant.~~

Requirements R1 ~~and R2~~ states that if inadequate vegetation management allows vegetation to encroach within the MVCD distance as shown in Table 2, it is a violation of the standard. Table 2 distances are the minimum clearances that will prevent spark-over based on the Gallet equations. These requirements assume that transmission lines and their conductors are operating within their Rating. If a line conductor is intentionally or inadvertently operated beyond its Rating and Rated Electrical Operating Condition (potentially in violation of other standards), the occurrence of a clearance encroachment may occur solely due to that condition. For example, emergency actions taken by an applicable Transmission Owner or applicable Generator Owner or Reliability Coordinator to protect an Interconnection may cause excessive sagging and an outage. Another example would be ice loading beyond the line's Rating and Rated Electrical Operating Condition. Such vegetation-related encroachments and outages are not violations of this standard.

Evidence of failures to adequately manage vegetation include real-time observation of a vegetation encroachment into the MVCD (absent a Sustained Outage), or a vegetation-related encroachment resulting in a Sustained Outage due to a fall-in from inside the ROW, or a vegetation-related encroachment resulting in a Sustained Outage due to the blowing together of the lines and vegetation located inside the ROW, or a vegetation-related encroachment resulting in a Sustained Outage due to a grow-in. Faults which do not cause a Sustained outage and which are confirmed to have been caused by vegetation encroachment within the MVCD are considered the equivalent of a Real-time observation for violation severity levels.

With this approach, the VSLs for R1 ~~and R2~~ are structured such that they directly correlate to the severity of a failure of an applicable Transmission Owner or applicable Generator Owner to manage vegetation and to the corresponding performance level of the Transmission Owner's vegetation program's ability to meet the objective of "preventing the risk of those vegetation related outages that could lead to Cascading." Thus violation severity increases with an applicable Transmission Owner's or applicable Generator Owner's inability to meet this goal and its potential of leading to a Cascading event. The additional benefits of such a combination are that it simplifies the standard and clearly defines performance for compliance. A performance-based requirement of this nature will promote high quality, cost effective vegetation management programs that will deliver the overall end result of improved reliability to the system.

Multiple Sustained Outages on an individual line can be caused by the same vegetation. For example initial investigations and corrective actions may not identify and remove the actual outage cause then another outage occurs after the line is re-energized and previous high conductor temperatures return. Such events are considered to be a single vegetation-related Sustained Outage under the standard where the Sustained Outages occur within a 24 hour period.

If the applicable Transmission Owner or applicable Generator Owner has applicable lines operated at nominal voltage levels not listed in Table 2, then the applicable TO or applicable GO should use the next largest clearance distance based on the next highest nominal voltage in the table to determine an acceptable distance.

### **Requirement R3:**

R3 is a competency based requirement concerned with the maintenance strategies, procedures, processes, or specifications, an applicable Transmission Owner or applicable Generator Owner uses for vegetation management.

An adequate transmission vegetation management program formally establishes the approach the applicable Transmission Owner or applicable Generator Owner uses to plan and perform vegetation work to prevent transmission Sustained Outages and minimize risk to the transmission system. The approach provides the basis for evaluating the intent, allocation of appropriate resources, and the competency of the applicable Transmission Owner or applicable Generator Owner in managing vegetation. There are many acceptable approaches to manage vegetation and avoid Sustained Outages. However, the applicable Transmission Owner or applicable Generator Owner must be able to show the documentation of its approach and how it conducts work to maintain clearances.

An example of one approach commonly used by industry is ANSI Standard A300, part 7. However, regardless of the approach a utility uses to manage vegetation, any approach an applicable Transmission Owner or applicable Generator Owner chooses to use will generally contain the following elements:

1. *the maintenance strategy used (such as minimum vegetation-to-conductor distance or maximum vegetation height) to ensure that MVCD clearances are never violated*
2. *the work methods that the applicable Transmission Owner or applicable Generator Owner uses to control vegetation*
3. *a stated Vegetation Inspection frequency*
4. *an annual work plan*

The conductor's position in space at any point in time is continuously changing in reaction to a number of different loading variables. Changes in vertical and horizontal conductor positioning are the result of thermal and physical loads applied to the line. Thermal loading is a function of line current and the combination of numerous variables influencing ambient heat dissipation including wind velocity/direction, ambient air temperature and precipitation. Physical loading applied to the conductor affects sag and sway by combining physical factors such as ice and wind loading. The movement of the transmission line conductor and the MVCD is illustrated in Figure 1 below.

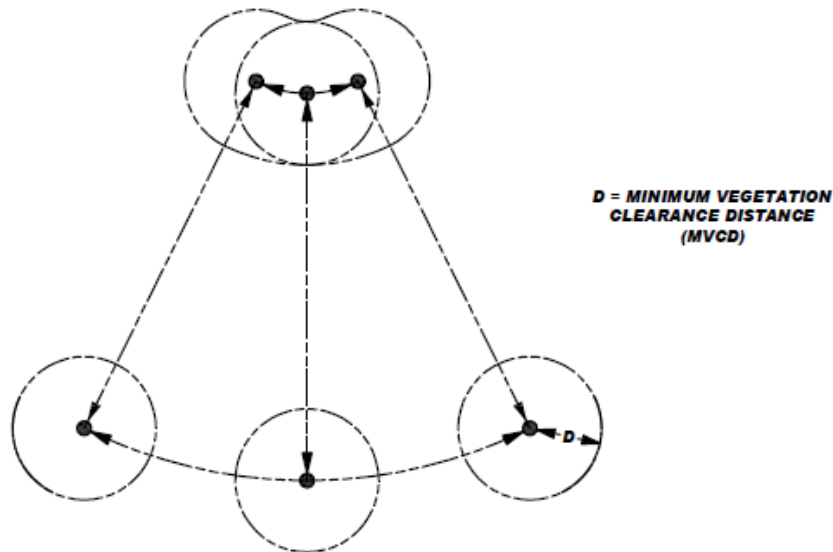


Figure 1

A cross-section view of a single conductor at a given point along the span is shown with six possible conductor positions due to movement resulting from thermal and mechanical loading.

**Requirement R4:**

R4 is a risk-based requirement. It focuses on preventative actions to be taken by the applicable Transmission Owner or applicable Generator Owner for the mitigation of Fault risk when a vegetation threat is confirmed. R4 involves the notification of potentially threatening vegetation conditions, without any intentional delay, to the control center holding switching authority for that specific transmission line. Examples of acceptable unintentional delays may include communication system problems (for example, cellular service or two-way radio disabled), crews located in remote field locations with no communication access, delays due to severe weather, etc.

Confirmation is key that a threat actually exists due to vegetation. This confirmation could be in the form of an applicable Transmission Owner or applicable Generator Owner employee who personally identifies such a threat in the field. Confirmation could also be made by sending out an employee to evaluate a situation reported by a landowner.

Vegetation-related conditions that warrant a response include vegetation that is near or encroaching into the MVCD (a grow-in issue) or vegetation that could fall into the transmission conductor (a fall-in issue). A knowledgeable verification of the risk would include an assessment of the possible sag or movement of the conductor while operating between no-load conditions and its rating.

The applicable Transmission Owner or applicable Generator Owner has the responsibility to ensure the proper communication between field personnel and the control center to allow the control center to take the appropriate action until or as the vegetation threat is relieved. Appropriate actions may include a temporary reduction in the line loading, switching the line out of service, or other preparatory actions in recognition of the increased risk of outage on that circuit. The notification of the threat should be communicated in terms of minutes or hours as opposed to a longer time frame for corrective action plans (see R5).

All potential grow-in or fall-in vegetation-related conditions will not necessarily cause a Fault at any moment. For example, some applicable Transmission Owners or applicable Generator Owners may have a danger tree identification program that identifies trees for removal with the potential to fall near the line. These trees would not require notification to the control center unless they pose an immediate fall-in threat.

### **Requirement R5:**

R5 is a risk-based requirement. It focuses upon preventative actions to be taken by the applicable Transmission Owner or applicable Generator Owner for the mitigation of Sustained Outage risk when temporarily constrained from performing vegetation maintenance. The intent of this requirement is to deal with situations that prevent the applicable Transmission Owner or applicable Generator Owner from performing planned vegetation management work and, as a result, have the potential to put the transmission line at risk. Constraints to performing vegetation maintenance work as planned could result from legal injunctions filed by property owners, the discovery of easement stipulations which limit the applicable Transmission Owner's or applicable Generator Owner's rights, or other circumstances.

This requirement is not intended to address situations where the transmission line is not at potential risk and the work event can be rescheduled or re-planned using an alternate work methodology. For example, a land owner may prevent the planned use of herbicides to control incompatible vegetation outside of the MVCD, but agree to the use of mechanical clearing. In this case the applicable Transmission Owner or applicable Generator Owner is not under any immediate time constraint for achieving the management objective, can easily reschedule work using an alternate approach, and therefore does not need to take interim corrective action.

However, in situations where transmission line reliability is potentially at risk due to a constraint, the applicable Transmission Owner or applicable Generator Owner is required to take an interim corrective action to mitigate the potential risk to the transmission line. A wide range of actions can be taken to address various situations. General considerations include:

- Identifying locations where the applicable Transmission Owner or applicable Generator Owner is constrained from performing planned vegetation maintenance work which potentially leaves the transmission line at risk.
- Developing the specific action to mitigate any potential risk associated with not performing the vegetation maintenance work as planned.



- Documenting and tracking the specific action taken for the location.
- In developing the specific action to mitigate the potential risk to the transmission line the applicable Transmission Owner or applicable Generator Owner could consider location specific measures such as modifying the inspection and/or maintenance intervals. Where a legal constraint would not allow any vegetation work, the interim corrective action could include limiting the loading on the transmission line.
- The applicable Transmission Owner or applicable Generator Owner should document and track the specific corrective action taken at each location. This location may be indicated as one span, one tree or a combination of spans on one property where the constraint is considered to be temporary.

### **Requirement R6:**

R6 is a risk-based requirement. This requirement sets a minimum time period for completing Vegetation Inspections. The provision that Vegetation Inspections can be performed in conjunction with general line inspections facilitates a Transmission Owner's ability to meet this requirement. However, the applicable Transmission Owner or applicable Generator Owner may determine that more frequent vegetation specific inspections are needed to maintain reliability levels, based on factors such as anticipated growth rates of the local vegetation, length of the local growing season, limited ROW width, and local rainfall. Therefore it is expected that some transmission lines may be designated with a higher frequency of inspections.

The VSLs for Requirement R6 have levels ranked by the failure to inspect a percentage of the applicable lines to be inspected. To calculate the appropriate VSL the applicable Transmission Owner or applicable Generator Owner may choose units such as: circuit, pole line, line miles or kilometers, etc.

For example, when an applicable Transmission Owner or applicable Generator Owner operates 2,000 miles of applicable transmission lines this applicable Transmission Owner or applicable Generator Owner will be responsible for inspecting all the 2,000 miles of lines at least once during the calendar year. If one of the included lines was 100 miles long, and if it was not inspected during the year, then the amount failed to inspect would be  $100/2000 = 0.05$  or 5%. The "Low VSL" for R6 would apply in this example.

### **Requirement R7:**

R7 is a risk-based requirement. The applicable Transmission Owner or applicable Generator Owner is required to complete its annual work plan for vegetation management to accomplish the purpose of this standard. Modifications to the work plan in response to changing conditions or to findings from vegetation inspections may be made and documented provided they do not put the transmission system at risk. The annual work plan requirement is not intended to necessarily require a "span-by-span", or even a "line-by-line" detailed description of all work to be performed. It is only intended to require that the applicable Transmission Owner or applicable Generator Owner provide evidence of annual planning and execution of a vegetation

management maintenance approach which successfully prevents encroachment of vegetation into the MVCD.

When an applicable Transmission Owner or applicable Generator Owner identifies 1,000 miles of applicable transmission lines to be completed in the applicable Transmission Owner's or applicable Generator Owner's annual plan, the applicable Transmission Owner or applicable Generator Owner will be responsible completing those identified miles. If an applicable Transmission Owner or applicable Generator Owner makes a modification to the annual plan that does not put the transmission system at risk of an encroachment the annual plan may be modified. If 100 miles of the annual plan is deferred until next year the calculation to determine what percentage was completed for the current year would be:  $1000 - 100$  (deferred miles) = 900 modified annual plan, or  $900 / 900 = 100\%$  completed annual miles. If an applicable Transmission Owner or applicable Generator Owner only completed 875 of the total 1000 miles with no acceptable documentation for modification of the annual plan the calculation for failure to complete the annual plan would be:  $1000 - 875 = 125$  miles failed to complete then,  $125$  miles (not completed) /  $1000$  total annual plan miles =  $12.5\%$  failed to complete.

The ability to modify the work plan allows the applicable Transmission Owner or applicable Generator Owner to change priorities or treatment methodologies during the year as conditions or situations dictate. For example recent line inspections may identify unanticipated high priority work, weather conditions (drought) could make herbicide application ineffective during the plan year, or a major storm could require redirecting local resources away from planned maintenance. This situation may also include complying with mutual assistance agreements by moving resources off the applicable Transmission Owner's or applicable Generator Owner's system to work on another system. Any of these examples could result in acceptable deferrals or additions to the annual work plan provided that they do not put the transmission system at risk of a vegetation encroachment.

In general, the vegetation management maintenance approach should use the full extent of the applicable Transmission Owner's or applicable Generator Owner's easement, fee simple and other legal rights allowed. A comprehensive approach that exercises the full extent of legal rights on the ROW is superior to incremental management because in the long term it reduces the overall potential for encroachments, and it ensures that future planned work and future planned inspection cycles are sufficient.

When developing the annual work plan the applicable Transmission Owner or applicable Generator Owner should allow time for procedural requirements to obtain permits to work on federal, state, provincial, public, tribal lands. In some cases the lead time for obtaining permits may necessitate preparing work plans more than a year prior to work start dates. Applicable Transmission Owners or applicable Generator Owners may also need to consider those special landowner requirements as documented in easement instruments.

This requirement sets the expectation that the work identified in the annual work plan will be completed as planned. Therefore, deferrals or relevant changes to the annual plan shall be documented. Depending on the planning and documentation format used by the applicable Transmission Owner or applicable Generator Owner, evidence of successful annual work plan execution could consist of signed-off work orders, signed contracts, printouts from work management systems, spreadsheets of planned versus completed work, timesheets, work inspection reports, or paid invoices. Other evidence may include photographs, and walk-through reports.

### **Notes:**

The SDT determined that the use of IEEE 516-2003 in version 1 of FAC-003 was a misapplication. The SDT consulted specialists who advised that the Gallet equation would be a technically justified method. The explanation of why the Gallet approach is more appropriate is explained in the paragraphs below.

The drafting team sought a method of establishing minimum clearance distances that uses realistic weather conditions and realistic maximum transient over-voltages factors for in-service transmission lines.

The SDT considered several factors when looking at changes to the minimum vegetation to conductor distances in FAC-003-1:

- avoid the problem associated with referring to tables in another standard (IEEE-516-2003)
- transmission lines operate in non-laboratory environments (wet conditions)
- transient over-voltage factors are lower for in-service transmission lines than for inadvertently re-energized transmission lines with trapped charges.

FAC-003-1 used the minimum air insulation distance (MAID) without tools formula provided in IEEE 516-2003 to determine the minimum distance between a transmission line conductor and vegetation. The equations and methods provided in IEEE 516 were developed by an IEEE Task Force in 1968 from test data provided by thirteen independent laboratories. The distances provided in IEEE 516 Tables 5 and 7 are based on the withstand voltage of a dry rod-rod air gap, or in other words, dry laboratory conditions. Consequently, the validity of using these distances in an outside environment application has been questioned.

FAC-003-1 allowed Transmission Owners to use either Table 5 or Table 7 to establish the minimum clearance distances. Table 7 could be used if the Transmission Owner knew the maximum transient over-voltage factor for its system. Otherwise, Table 5 would have to be used. Table 5 represented minimum air insulation distances under the worst possible case for transient over-voltage factors. These worst case transient over-voltage factors were as follows: 3.5 for voltages up to 362 kV phase to phase; 3.0 for 500 - 550 kV phase to phase; and 2.5 for 765 to 800 kV phase to phase. These worst case over-voltage factors were also a cause for concern in this particular application of the distances.

In general, the worst case transient over-voltages occur on a transmission line that is inadvertently re-energized immediately after the line is de-energized and a trapped charge is still present. The intent of FAC-003 is to keep a transmission line that is in service from becoming de-energized (i.e. tripped out) due to spark-over from the line conductor to nearby vegetation. Thus, the worst case transient overvoltage assumptions are not appropriate for this application. Rather, the appropriate over voltage values are those that occur only while the line is energized.

Typical values of transient over-voltages of in-service lines are not readily available in the literature because they are negligible compared with the maximums. A conservative value for the maximum transient over-voltage that can occur anywhere along the length of an in-service ac line was approximately 2.0 per unit. This value was a conservative estimate of the transient over-voltage that is created at the point of application (e.g. a substation) by switching a capacitor bank without pre-insertion devices (e.g. closing resistors). At voltage levels where capacitor banks are not very common (e.g. Maximum System Voltage of 362 kV), the maximum transient over-voltage of an in-service ac line are created by fault initiation on adjacent ac lines and shunt reactor bank switching. These transient voltages are usually 1.5 per unit or less.

Even though these transient over-voltages will not be experienced at locations remote from the bus at which they are created, in order to be conservative, it is assumed that all nearby ac lines are subjected to this same level of over-voltage. Thus, a maximum transient over-voltage factor of 2.0 per unit for transmission lines operated at 302 kV and below was considered to be a realistic maximum in this application. Likewise, for ac transmission lines operated at Maximum System Voltages of 362 kV and above a transient over-voltage factor of 1.4 per unit was considered a realistic maximum.

The Gallet equations are an accepted method for insulation coordination in tower design. These equations are used for computing the required strike distances for proper transmission line insulation coordination. They were developed for both wet and dry applications and can be used with any value of transient over-voltage factor. The Gallet equation also can take into account various air gap geometries. This approach was used to design the first 500 kV and 765 kV lines in North America.

If one compares the MAID using the IEEE 516-2003 Table 7 (table D.5 for English values) with the critical spark-over distances computed using the Gallet wet equations, for each of the nominal voltage classes and identical transient over-voltage factors, the Gallet equations yield a more conservative (larger) minimum distance value.

Distances calculated from either the IEEE 516 (dry) formulas or the Gallet “wet” formulas are not vastly different when the same transient overvoltage factors are used; the “wet” equations will consistently produce slightly larger distances than the IEEE 516 equations when the same transient overvoltage is used. While the IEEE 516 equations were only developed for dry conditions the Gallet equations have provisions to calculate spark-over distances for both wet and dry conditions.

Since no empirical data for spark over distances to live vegetation existed at the time version 3 was developed, the SDT chose a proven method that has been used in other EHV applications. The Gallet equations relevance to wet conditions and the selection of a Transient Overvoltage Factor that is consistent with the absence of trapped charges on an in-service transmission line make this methodology a better choice.

The following table is an example of the comparison of distances derived from IEEE 516 and the Gallet equations.

**Comparison of spark-over distances computed using Gallet wet equations vs.  
IEEE 516-2003 MAID distances**

<b>( AC ) Nom System Voltage (kV)</b>	<b>( AC ) Max System Voltage (kV)</b>	<b>Transient Over-voltage Factor (T)</b>	<b>Clearance (ft.) Gallet (wet) @ Alt. 3000 feet</b>	<b>Table 7 (Table D.5 for feet) IEEE 516-2003 MAID (ft) @ Alt. 3000 feet</b>
765	800	2.0	14.36	13.95
500	550	2.4	11.0	10.07
345	362	3.0	8.55	7.47
230	242	3.0	5.28	4.2
115	121	3.0	2.46	2.1

### **Rationale:**

During development of this standard, text boxes were embedded within the standard to explain the rationale for various parts of the standard. Upon BOT approval, the text from the rationale text boxes was moved to this section.

### **Rationale for Applicability (section 4.2.4):**

The areas excluded in 4.2.4 were excluded based on comments from industry for reasons summarized as follows:

- 1) There is a very low risk from vegetation in this area. Based on an informal survey, no TOs reported such an event.
- 2) Substations, switchyards, and stations have many inspection and maintenance activities that are necessary for reliability. Those existing process manage the threat. As such, the formal steps in this standard are not well suited for this environment.
- 3) Specifically addressing the areas where the standard does and does not apply makes the standard clearer.

### **Rationale for Applicability (section 4.3):**

Within the text of NERC Reliability Standard FAC-003-3, “transmission line(s)” and “applicable line(s)” can also refer to the generation Facilities as referenced in 4.3 and its subsections.

### **Rationale for R1 ~~and R2~~:**

Lines with the highest significance to reliability are covered in R1; all other lines are covered in R2.

Rationale for the types of failure to manage vegetation which are listed in order of increasing degrees of severity in non-compliant performance as it relates to a failure of an applicable Transmission Owner's or applicable Generator Owner's vegetation maintenance program:

1. This management failure is found by routine inspection or Fault event investigation, and is normally symptomatic of unusual conditions in an otherwise sound program.
2. This management failure occurs when the height and location of a side tree within the ROW is not adequately addressed by the program.
3. This management failure occurs when side growth is not adequately addressed and may be indicative of an unsound program.
4. This management failure is usually indicative of a program that is not addressing the most fundamental dynamic of vegetation management, (i.e. a grow-in under the line). If this type of failure is pervasive on multiple lines, it provides a mechanism for a Cascade.

### **Rationale for R3:**

The documentation provides a basis for evaluating the competency of the applicable Transmission Owner's or applicable Generator Owner's vegetation program. There may be many acceptable approaches to maintain clearances. Any approach must demonstrate that the

applicable Transmission Owner or applicable Generator Owner avoids vegetation-to-wire conflicts under all Ratings and all Rated Electrical Operating Conditions.

### **Rationale for R4:**

This is to ensure expeditious communication between the applicable Transmission Owner or applicable Generator Owner and the control center when a critical situation is confirmed.

### **Rationale for R5:**

Legal actions and other events may occur which result in constraints that prevent the applicable Transmission Owner or applicable Generator Owner from performing planned vegetation maintenance work.

In cases where the transmission line is put at potential risk due to constraints, the intent is for the applicable Transmission Owner and applicable Generator Owner to put interim measures in place, rather than do nothing.

The corrective action process is not intended to address situations where a planned work methodology cannot be performed but an alternate work methodology can be used.

### **Rationale for R6:**

Inspections are used by applicable Transmission Owners and applicable Generator Owners to assess the condition of the entire ROW. The information from the assessment can be used to determine risk, determine future work and evaluate recently-completed work. This requirement sets a minimum Vegetation Inspection frequency of once per calendar year but with no more than 18 months between inspections on the same ROW. Based upon average growth rates across North America and on common utility practice, this minimum frequency is reasonable. Transmission Owners should consider local and environmental factors that could warrant more frequent inspections.

### **Rationale for R7:**

This requirement sets the expectation that the work identified in the annual work plan will be completed as planned. It allows modifications to the planned work for changing conditions, taking into consideration anticipated growth of vegetation and all other environmental factors, provided that those modifications do not put the transmission system at risk of a vegetation encroachment.

Exhibit A-4

TOP-001-6 (Clean and Redline to Last Approved)



## A. Introduction

1. **Title:** Transmission Operations
2. **Number:** TOP-001-6
3. **Purpose:** To prevent instability, uncontrolled separation, or Cascading outages that adversely impact the reliability of the Interconnection by ensuring prompt action to prevent or mitigate such occurrences.
4. **Applicability:**
  - 4.1. **Functional Entities:**
    - 4.1.1. Balancing Authority
    - 4.1.2. Transmission Operator
    - 4.1.3. Generator Operator
    - 4.1.4. Distribution Provider
5. **Effective Date:** See Implementation Plan

## B. Requirements and Measures

- R1.** Each Transmission Operator shall act to maintain the reliability of its Transmission Operator Area via its own actions or by issuing Operating Instructions. *[Violation Risk Factor: High][Time Horizon: Same-Day Operations, Real-time Operations]*
- M1.** Each Transmission Operator shall have and provide evidence which may include but is not limited to dated operator logs, dated records, dated and time-stamped voice recordings or dated transcripts of voice recordings, electronic communications, or equivalent documentation, that will be used to determine that it acted to maintain the reliability of its Transmission Operator Area via its own actions or by issuing Operating Instructions.
- R2.** Each Balancing Authority shall act to maintain the reliability of its Balancing Authority Area via its own actions or by issuing Operating Instructions. *[Violation Risk Factor: High][Time Horizon: Same-Day Operations, Real-time Operations]*
- M2.** Each Balancing Authority shall have and provide evidence which may include but is not limited to dated operator logs, dated records, dated and time-stamped voice recordings or dated transcripts of voice recordings, electronic communications, or equivalent documentation, that will be used to determine that it acted to maintain the reliability of its Balancing Authority Area via its own actions or by issuing Operating Instructions.
- R3.** Each Balancing Authority, Generator Operator, and Distribution Provider shall comply with each Operating Instruction issued by its Transmission Operator(s), unless such action cannot be physically implemented or it would violate safety, equipment, regulatory, or statutory requirements. *[Violation Risk Factor: High] [Time Horizon: Same-Day Operations, Real-Time Operations]*
- M3.** Each Balancing Authority, Generator Operator, and Distribution Provider shall make available upon request, evidence that it complied with each Operating Instruction issued by the Transmission Operator(s) unless such action could not be physically implemented or it would have violated safety, equipment, regulatory, or statutory requirements. Such evidence could include but is not limited to dated operator logs, voice recordings or transcripts of voice recordings, electronic communications, or other equivalent evidence in electronic or hard copy format. In such cases, the Balancing Authority, Generator Operator, and Distribution Provider shall have and provide copies of the safety, equipment, regulatory, or statutory requirements as evidence for not complying with the Transmission Operator's Operating Instruction. If such a situation has not occurred, the Balancing Authority, Generator Operator, or Distribution Provider may provide an attestation.
- R4.** Each Balancing Authority, Generator Operator, and Distribution Provider shall inform its Transmission Operator of its inability to comply with an Operating Instruction issued by its Transmission Operator. *[Violation Risk Factor: High] [Time Horizon: Same-Day Operations, Real-Time Operations]*

- M4.** Each Balancing Authority, Generator Operator, and Distribution Provider shall make available upon request, evidence which may include but is not limited to dated operator logs, voice recordings or transcripts of voice recordings, electronic communications, or equivalent evidence in electronic or hard copy format, that it informed its Transmission Operator of its inability to comply with its Operating Instruction issued. If such a situation has not occurred, the Balancing Authority, Generator Operator, or Distribution Provider may provide an attestation.
- R5.** Each Transmission Operator, Generator Operator, and Distribution Provider shall comply with each Operating Instruction issued by its Balancing Authority, unless such action cannot be physically implemented or it would violate safety, equipment, regulatory, or statutory requirements. *[Violation Risk Factor: High] [Time Horizon: Same-Day Operations, Real-Time Operations]*
- M5.** Each Transmission Operator, Generator Operator, and Distribution Provider shall make available upon request, evidence that it complied with each Operating Instruction issued by its Balancing Authority unless such action could not be physically implemented or it would have violated safety, equipment, regulatory, or statutory requirements. Such evidence could include but is not limited to dated operator logs, voice recordings or transcripts of voice recordings, electronic communications, or other equivalent evidence in electronic or hard copy format. In such cases, the Transmission Operator, Generator Operator, and Distribution Provider shall have and provide copies of the safety, equipment, regulatory, or statutory requirements as evidence for not complying with the Balancing Authority's Operating Instruction. If such a situation has not occurred, the Transmission Operator, Generator Operator, or Distribution Provider may provide an attestation.
- R6.** Each Transmission Operator, Generator Operator, and Distribution Provider shall inform its Balancing Authority of its inability to comply with an Operating Instruction issued by its Balancing Authority. *[Violation Risk Factor: High] [Time Horizon: Same-Day Operations, Real-Time Operations]*
- M6.** Each Transmission Operator, Generator Operator, and Distribution Provider shall make available upon request, evidence which may include but is not limited to dated operator logs, voice recordings or transcripts of voice recordings, electronic communications, or equivalent evidence in electronic or hard copy format, that it informed its Balancing Authority of its inability to comply with its Operating Instruction. If such a situation has not occurred, the Transmission Operator, Generator Operator, or Distribution Provider may provide an attestation.
- R7.** Each Transmission Operator shall assist other Transmission Operators within its Reliability Coordinator Area, if requested and able, provided that the requesting Transmission Operator has implemented its comparable Emergency procedures, unless such assistance cannot be physically implemented or would violate safety, equipment, regulatory, or statutory requirements. *[Violation Risk Factor: High] [Time Horizon: Real-Time Operations]*

- M7.** Each Transmission Operator shall make available upon request, evidence that comparable requested assistance, if able, was provided to other Transmission Operators within its Reliability Coordinator Area unless such assistance could not be physically implemented or would have violated safety, equipment, regulatory, or statutory requirements. Such evidence could include but is not limited to dated operator logs, voice recordings or transcripts of voice recordings, electronic communications, or other equivalent evidence in electronic or hard copy format. If no request for assistance was received, the Transmission Operator may provide an attestation.
- R8.** Each Transmission Operator shall inform its Reliability Coordinator, known impacted Balancing Authorities, and known impacted Transmission Operators of its actual or expected operations that result in, or could result in, an Emergency. *[Violation Risk Factor: High] [Time Horizon: Operations Planning, Same-Day Operations, Real-Time Operations]*
- M8.** Each Transmission Operator shall make available upon request, evidence that it informed its Reliability Coordinator, known impacted Balancing Authorities, and known impacted Transmission Operators of its actual or expected operations that result in, or could result in, an Emergency. Such evidence could include but is not limited to dated operator logs, voice recordings or transcripts of voice recordings, electronic communications, or other equivalent evidence. If no such situations have occurred, the Transmission Operator may provide an attestation.
- R9.** Each Balancing Authority and Transmission Operator shall notify its Reliability Coordinator and known impacted interconnected entities of all planned outages, and unplanned outages of 30 minutes or more, for telemetering and control equipment, monitoring and assessment capabilities, and associated communication channels between the affected entities. *[Violation Risk Factor: Medium] [Time Horizon: Operations Planning, Same-Day Operations, Real-Time Operations]*
- M9.** Each Balancing Authority and Transmission Operator shall make available upon request, evidence that it notified its Reliability Coordinator and known impacted interconnected entities of all planned outages, and unplanned outages of 30 minutes or more, for telemetering and control equipment, monitoring and assessment capabilities, and associated communication channels. Such evidence could include but is not limited to dated operator logs, voice recordings or transcripts of voice recordings, electronic communications, or other equivalent evidence. If such a situation has not occurred, the Balancing Authority or Transmission Operator may provide an attestation.
- R10.** Each Transmission Operator shall perform the following for determining System Operating Limit (SOL) exceedances within its Transmission Operator Area: *[Violation Risk Factor: High] [Time Horizon: Real-Time Operations]*
- 10.1.** Monitor Facilities within its Transmission Operator Area;

- 10.2.** Monitor the status of Remedial Action Schemes within its Transmission Operator Area;
  - 10.3.** Monitor non-BES facilities within its Transmission Operator Area identified as necessary by the Transmission Operator;
  - 10.4.** Obtain and utilize status, voltages, and flow data for Facilities outside its Transmission Operator Area identified as necessary by the Transmission Operator;
  - 10.5.** Obtain and utilize the status of Remedial Action Schemes outside its Transmission Operator Area identified as necessary by the Transmission Operator; and
  - 10.6.** Obtain and utilize status, voltages, and flow data for non-BES facilities outside its Transmission Operator Area identified as necessary by the Transmission Operator.
- M10.** Each Transmission Operator shall have, and provide upon request, evidence that could include but is not limited to Energy Management System description documents, computer printouts, Supervisory Control and Data Acquisition (SCADA) data collection, or other equivalent evidence that will be used to confirm that it monitored or obtained and utilized data as required to determine any System Operating Limit (SOL) exceedances within its Transmission Operator Area.
- R11.** Each Balancing Authority shall monitor its Balancing Authority Area, including the status of Remedial Action Schemes that impact generation or Load, in order to maintain generation-Load-interchange balance within its Balancing Authority Area and support Interconnection frequency. *[Violation Risk Factor: High] [Time Horizon: Real-Time Operations]*
- M11.** Each Balancing Authority shall have, and provide upon request, evidence that could include but is not limited to Energy Management System description documents, computer printouts, SCADA data collection, or other equivalent evidence that will be used to confirm that it monitors its Balancing Authority Area, including the status of Remedial Action Schemes that impact generation or Load, in order to maintain generation-Load-interchange balance within its Balancing Authority Area and support Interconnection frequency.
- R12.** Each Transmission Operator shall not operate outside any identified Interconnection Reliability Operating Limit (IROL) for a continuous duration exceeding its associated IROL T<sub>v</sub>. *[Violation Risk Factor: High] [Time Horizon: Real-time Operations]*
- M12.** Each Transmission Operator shall make available evidence to show that for any occasion in which it operated outside any identified Interconnection Reliability Operating Limit (IROL), the continuous duration did not exceed its associated IROL T<sub>v</sub>. Such evidence could include but is not limited to dated computer logs or reports in electronic or hard copy format specifying the date, time, duration, and details of the

excursion. If such a situation has not occurred, the Transmission Operator may provide an attestation that an event has not occurred.

- R13.** Each Transmission Operator shall ensure that a Real-time Assessment is performed at least once every 30 minutes. *[Violation Risk Factor: High] [Time Horizon: Real-time Operations]*
- M13.** Each Transmission Operator shall have, and make available upon request, evidence to show it ensured that a Real-Time Assessment was performed at least once every 30 minutes. This evidence could include but is not limited to dated computer logs showing times the assessment was conducted, dated checklists, or other evidence.
- R14.** Each Transmission Operator shall initiate its Operating Plan to mitigate a SOL exceedance identified as part of its Real-time monitoring or Real-time Assessment. *[Violation Risk Factor: High] [Time Horizon: Real-time Operations]*
- M14.** Each Transmission Operator shall have evidence that it initiated its Operating Plan for mitigating SOL exceedances identified as part of its Real-time monitoring or Real-time Assessments. This evidence could include but is not limited to dated computer logs showing times the Operating Plan was initiated, dated checklists, or other evidence. Other evidence could include but is not limited to: Reliability Coordinator's SOL methodology, system logs/records showing successfully mitigated SOL exceedances in conjunction with Operating Plans (e.g. mutually agreed operating protocols between TOPs and their Reliability Coordinator, Operating Procedures, Operating Processes, operating policies, generator redispatch logs, equipment settings for automatically switched equipment and reactive power/voltage control devices, switching schedules, etc.).
- R15.** Each Transmission Operator shall inform its Reliability Coordinator of actions taken to return the System to within limits when a SOL has been exceeded in accordance with its Reliability Coordinator's SOL methodology. *[Violation Risk Factor: Medium] [Time Horizon: Real-Time Operations]*
- M15.** Each Transmission Operator shall make available evidence that it informed its Reliability Coordinator of actions taken to return the System to within limits when a SOL was exceeded in accordance with its Reliability Coordinator's SOL methodology. Such evidence could include but is not limited to dated operator logs, electronic communications, voice recordings or transcripts of voice recordings, or dated computer printouts. If such a situation has not occurred, the Transmission Operator may provide an attestation.
- R16.** Each Transmission Operator shall provide its System Operators with the authority to approve planned outages and maintenance of its telemetering and control equipment, monitoring and assessment capabilities, and associated communication channels between affected entities. *[Violation Risk Factor: High] [Time Horizon: Operations Planning, Same-Day Operations, Real-time Operations]*

- M16.** Each Transmission Operator shall have, and provide upon request, evidence that could include but is not limited to a documented procedure or equivalent evidence that will be used to confirm that the Transmission Operator has provided its System Operators with the authority to approve planned outages and maintenance of telemetering and control equipment, monitoring and assessment capabilities, and associated communication channels between affected entities.
- R17.** Each Balancing Authority shall provide its System Operators with the authority to approve planned outages and maintenance of its telemetering and control equipment, monitoring and assessment capabilities, and associated communication channels between affected entities. *[Violation Risk Factor: High] [Time Horizon: Operations Planning, Same-Day Operations, Real-time Operations]*
- M17.** Each Balancing Authority shall have, and provide upon request, evidence that could include but is not limited to a documented procedure or equivalent evidence that will be used to confirm that the Balancing Authority has provided its System Operators with the authority to approve planned outages and maintenance of its telemetering and control equipment, monitoring and assessment capabilities, and associated communication channels between affected entities.
- R18.** Each Transmission Operator shall operate to the most limiting parameter in instances where there is a difference in SOLs. *[Violation Risk Factor: High] [Time Horizon: Operations Planning, Same-Day Operations, Real-time Operations]*
- M18.** Each Transmission Operator shall have, and provide upon request, evidence that could include but is not limited to operator logs, voice recordings, electronic communications, or equivalent evidence that will be used to determine if it operated to the most limiting parameter in instances where there is a difference in SOLs.
- R19.** Reserved.
- M19.** Reserved.
- R20.** Each Transmission Operator shall have data exchange capabilities, with redundant and diversely routed data exchange infrastructure within the Transmission Operator's primary Control Center, for the exchange of Real-time data with its Reliability Coordinator, Balancing Authority, and the entities it has identified it needs data from in order for it to perform its Real-time monitoring and Real-time Assessments. *[Violation Risk Factor: High] [Time Horizon: Same-Day Operations, Real-time Operations]*
- M20.** Each Transmission Operator shall have, and provide upon request, evidence that could include, but is not limited to, system specifications, system diagrams, or other documentation that lists its data exchange capabilities, including redundant and diversely routed data exchange infrastructure within the Transmission Operator's primary Control Center, for the exchange of Real-time data with its Reliability Coordinator, Balancing Authority, and the entities it has identified it needs data from

in order to perform its Real-time monitoring and Real-time Assessments as specified in the requirement.

- R21.** Each Transmission Operator shall test its primary Control Center data exchange capabilities specified in Requirement R20 for redundant functionality at least once every 90 calendar days. If the test is unsuccessful, the Transmission Operator shall initiate action within two hours to restore redundant functionality. *[Violation Risk Factor: Medium ] [Time Horizon: Operations Planning]*
- M21.** Each Transmission Operator shall have, and provide upon request, evidence that it tested its primary Control Center data exchange capabilities specified in Requirement R20 for the redundant functionality, or experienced an event that demonstrated the redundant functionality; and, if the test was unsuccessful, initiated action within two hours to restore redundant functionality as specified in Requirement R21. Evidence could include, but is not limited to: dated and time-stamped test records, operator logs, voice recordings, or electronic communications.
- R22.** Reserved.
- M22.** Reserved.
- R23.** Each Balancing Authority shall have data exchange capabilities, with redundant and diversely routed data exchange infrastructure within the Balancing Authority's primary Control Center, for the exchange of Real-time data with its Reliability Coordinator, Transmission Operator, and the entities it has identified it needs data from in order for it to perform its Real-time monitoring and analysis functions. *[Violation Risk Factor: High] [Time Horizon: Same-Day Operations, Real-time Operations]*
- M23.** Each Balancing Authority shall have, and provide upon request, evidence that could include, but is not limited to, system specifications, system diagrams, or other documentation that lists its data exchange capabilities, including redundant and diversely routed data exchange infrastructure within the Balancing Authority's primary Control Center, for the exchange of Real-time data with its Reliability Coordinator, Transmission Operator, and the entities it has identified it needs data from in order to perform its Real-time monitoring and analysis functions as specified in the requirement.
- R24.** Each Balancing Authority shall test its primary Control Center data exchange capabilities specified in Requirement R23 for redundant functionality at least once every 90 calendar days. If the test is unsuccessful, the Balancing Authority shall initiate action within two hours to restore redundant functionality. *[Violation Risk Factor: Medium ] [Time Horizon: Operations Planning]*
- M24.** Each Balancing Authority shall have, and provide upon request, evidence that it tested its primary Control Center data exchange capabilities specified in Requirement R23 for redundant functionality, or experienced an event that demonstrated the redundant functionality; and, if the test was unsuccessful, initiated action within two



hours to restore redundant functionality as specified in Requirement R24. Evidence could include, but is not limited to: dated and time-stamped test records, operator logs, voice recordings, or electronic communications.

**R25.** Each Transmission Operator shall use the applicable Reliability Coordinator's SOL methodology when determining SOL exceedances for Real-time Assessments, Real-time monitoring, and Operational Planning Analysis. [*Violation Risk Factor: High*] [*Time Horizon: Same-Day Operations, Real-time Operations, Operations Planning*]

**M25.** Each Transmission Operator shall have, and provide upon request, evidence that it used the applicable Reliability Coordinator's SOL methodology when determining SOL exceedances for Real-time Assessments, Real-time monitoring, and Operational Planning Analysis. Evidence could include, but is not limited to: Reliability Coordinator's SOL methodology, Operating Plans, contingency sets, alarming and study reporting thresholds, operator logs, voice recordings or other equivalent evidence.

## C. Compliance

### 1. Compliance Monitoring Process

#### 1.1. Compliance Enforcement Authority:

“Compliance Enforcement Authority” means NERC or the Regional Entity, or any entity as otherwise designated by an Applicable Governmental Authority, in their respective roles of monitoring and/or enforcing compliance with mandatory and enforceable Reliability Standards in their respective jurisdictions.

#### 1.2. Evidence Retention:

The following evidence retention period(s) identify the period of time an entity is required to retain specific evidence to demonstrate compliance. For instances where the evidence retention period specified below is shorter than the time since the last audit, the Compliance Enforcement Authority may ask an entity to provide other evidence to show that it was compliant for the full-time period since the last audit.

The applicable entity shall keep data or evidence to show compliance as identified below unless directed by its Compliance Enforcement Authority to retain specific evidence for a longer period of time as part of an investigation.

- Each Balancing Authority, Transmission Operator, Generator Operator, and Distribution Provider shall each keep data or evidence for each applicable Requirement R1 through R11, and Measure M1 through M11, for the current calendar year and one previous calendar year, with the exception of operator logs and voice recordings which shall be retained for a minimum of 90 calendar days, unless directed by its Compliance Enforcement Authority to retain specific evidence for a longer period of time as part of an investigation.
- Each Transmission Operator shall retain evidence for three calendar years of any occasion in which it has exceeded an identified IROL and its associated IROL  $T_v$  as specified in Requirement R12 and Measure M12.
- Each Transmission Operator shall keep data or evidence for Requirement R13 and Measure M13 for a rolling 30-day period, unless directed by its Compliance Enforcement Authority to retain specific evidence for a longer period of time as part of an investigation.
- Each Transmission Operator shall retain evidence and that it initiated its Operating Plan to mitigate a SOL exceedance as specified in Requirement R14 and Measurement M14 for rolling 12 months.
- Each Transmission Operator and Balancing Authority shall each keep data or evidence for each applicable Requirement R15 through R18, and Measure M15 through M18 for the current calendar year and one

previous calendar year, with the exception of operator logs and voice recordings which shall be retained for a minimum of 90 calendar days.

- Each Transmission Operator shall keep data or evidence for Requirement R20 and Measure M20 for the current calendar year and one previous calendar year.
- Each Transmission Operator shall keep evidence for Requirement R21 and Measure M21 for the most recent twelve calendar months, with the exception of operator logs and voice recordings which shall be retained for a minimum of 90 calendar days.
- Each Balancing Authority shall keep data or evidence for Requirement R23 and Measure M23 for the current calendar year and one previous calendar year.
- Each Balancing Authority shall keep evidence for Requirement R24 and Measure M24 for the most recent twelve calendar months, with the exception of operator logs and voice recordings which shall be retained for a minimum of 90 calendar days.
- Each Transmission Operator shall retain evidence that it used the applicable Reliability Coordinator's SOL methodology when determining SOL exceedances for Real-time Assessments, Real-time monitoring, and Operational Planning Analysis as specified in Requirement R25 and Measurement M25 for a rolling 12 months.

**1.3. Compliance Monitoring and Enforcement Program**

As defined in the NERC Rules of Procedure, "Compliance Monitoring and Enforcement Program" refers to the identification of the processes that will be used to evaluate data or information for the purpose of assessing performance or outcomes with the associated Reliability Standard.

### Violation Severity Levels

R #	Violation Severity Levels			
	Lower VSL	Moderate VSL	High VSL	Severe VSL
<b>R1.</b>	N/A	N/A	N/A	The Transmission Operator failed to act to maintain the reliability of its Transmission Operator Area via its own actions or by issuing Operating Instructions.
<b>R2.</b>	N/A	N/A	N/A	The Balancing Authority failed to act to maintain the reliability of its Balancing Authority Area via its own actions or by issuing Operating Instructions.
<b>R3.</b>	N/A	N/A	N/A	The responsible entity did not comply with an Operating Instruction issued by the Transmission Operator, and such action could have been physically implemented and would not have violated safety, equipment, regulatory, or statutory requirements.
<b>R4.</b>	N/A	N/A	N/A	The responsible entity did not inform its Transmission Operator of its inability to

R #	Violation Severity Levels			
	Lower VSL	Moderate VSL	High VSL	Severe VSL
				comply with an Operating Instruction issued by its Transmission Operator.
R5.	N/A	N/A	N/A	The responsible entity did not comply with an Operating Instruction issued by the Balancing Authority, and such action could have been physically implemented and would not have violated safety, equipment, regulatory, or statutory requirements.
R6.	N/A	N/A	N/A	The responsible entity did not inform its Balancing Authority of its inability to comply with an Operating Instruction issued by its Balancing Authority.
R7.	N/A	N/A	N/A	The Transmission Operator did not provide comparable assistance to other Transmission Operators within its Reliability Coordinator Area, when requested and able, and the

R #	Violation Severity Levels			
	Lower VSL	Moderate VSL	High VSL	Severe VSL
				requesting entity had implemented its Emergency procedures, and such actions could have been physically implemented and would not have violated safety, equipment, regulatory, or statutory requirements.
<b>R8.</b>	<p>The Transmission Operator did not inform one known impacted Transmission Operator or 5% or less of the known impacted Transmission Operators, whichever is greater, of its actual or expected operations that resulted in, or could have resulted in, an Emergency on respective Transmission Operator Areas.</p> <p>OR,</p> <p>The Transmission Operator did not inform one known impacted</p>	<p>The Transmission Operator did not inform two known impacted Transmission Operators or more than 5% and less than or equal to 10% of the known impacted Transmission Operators, whichever is greater, of its actual or expected operations that resulted in, or could have resulted in, an Emergency on respective Transmission Operator Areas.</p> <p>OR,</p> <p>The Transmission Operator did not inform two known impacted Balancing</p>	<p>The Transmission Operator did not inform three known impacted Transmission Operators or more than 10% and less than or equal to 15% of the known impacted Transmission Operators, whichever is greater, of its actual or expected operations that resulted in, or could have resulted in, an Emergency on respective Transmission Operator Areas.</p> <p>OR,</p> <p>The Transmission Operator did not inform three known impacted Balancing</p>	<p>The Transmission Operator did not inform its Reliability Coordinator of its actual or expected operations that resulted in, or could have resulted in, an Emergency on those respective Transmission Operator Areas.</p> <p>OR</p> <p>The Transmission Operator did not inform four or more known impacted Transmission Operators or more than 15% of the known impacted Transmission Operators of its actual or expected</p>

R #	Violation Severity Levels			
	Lower VSL	Moderate VSL	High VSL	Severe VSL
	Balancing Authorities or 5% or less of the known impacted Balancing Authorities, whichever is greater, of its actual or expected operations that resulted in, or could have resulted in, an Emergency on respective Balancing Authority Areas.	Authorities or more than 5% and less than or equal to 10% of the known impacted Balancing Authorities, whichever is greater, of its actual or expected operations that resulted in, or could have resulted in, an Emergency on respective Balancing Authority Areas.	Authorities or more than 10% and less than or equal to 15% of the known impacted Balancing Authorities, whichever is greater, of its actual or expected operations that resulted in, or could have resulted in, an Emergency on respective Balancing Authority Areas.	operations that resulted in, or could have resulted in, an Emergency on those respective Transmission Operator Areas. OR, The Transmission Operator did not inform four or more known impacted Balancing Authorities or more than 15% of the known impacted Balancing Authorities of its actual or expected operations that resulted in, or could have resulted in, an Emergency on respective Balancing Authority Areas.
<b>R9.</b>	The responsible entity did not notify one known impacted interconnected entity or 5% or less of the known impacted entities, whichever is greater, of a planned outage, or an unplanned outage of 30 minutes or more, for telemetering and control	The responsible entity did not notify two known impacted interconnected entities or more than 5% and less than or equal to 10% of the known impacted entities, whichever is greater, of a planned outage, or an unplanned outage of 30	The responsible entity did not notify three known impacted interconnected entities or more than 10% and less than or equal to 15% of the known impacted entities, whichever is greater, of a planned outage, or an unplanned outage of 30	The responsible entity did not notify its Reliability Coordinator of a planned outage, or an unplanned outage of 30 minutes or more, for telemetering and control equipment, monitoring and assessment capabilities, and associated communication channels.

R #	Violation Severity Levels			
	Lower VSL	Moderate VSL	High VSL	Severe VSL
	equipment, monitoring and assessment capabilities, or associated communication channels between the affected entities.	minutes or more, for telemetering and control equipment, monitoring and assessment capabilities, or associated communication channels between the affected entities.	minutes or more, for telemetering and control equipment, monitoring and assessment capabilities, or associated communication channels between the affected entities.	OR, The responsible entity did not notify four or more known impacted interconnected entities or more than 15% of the known impacted entities, whichever is greater, of a planned outage, or an unplanned outage of 30 minutes or more, for telemetering and control equipment, monitoring and assessment capabilities, or associated communication channels between the affected entities.
<b>R10.</b>	The Transmission Operator did not monitor, obtain, or utilize one of the items required or identified as necessary by the Transmission Operator and listed in Requirement R10, Part 10.1 through 10.6.	The Transmission Operator did not monitor, obtain, or utilize two of the items required or identified as necessary by the Transmission Operator and listed in Requirement R10, Part 10.1 through 10.6.	The Transmission Operator did not monitor, obtain, or utilize three of the items required or identified as necessary by the Transmission Operator and listed in Requirement R10, Part 10.1 through 10.6.	The Transmission Operator did not monitor, obtain, or utilize four or more of the items required or identified as necessary by the Transmission Operator and listed in Requirement R10 Part 10.1 through 10.6.



R #	Violation Severity Levels			
	Lower VSL	Moderate VSL	High VSL	Severe VSL
R11.	N/A	N/A	The Balancing Authority did not monitor the status of Remedial Action Schemes that impact generation or Load, in order to maintain generation-Load-interchange balance within its Balancing Authority Area and support Interconnection frequency.	The Balancing Authority did not monitor its Balancing Authority Area, in order to maintain generation-Load-interchange balance within its Balancing Authority Area and support Interconnection frequency.
R12.	N/A	N/A	N/A	The Transmission Operator exceeded an identified Interconnection Reliability Operating Limit (IROL) for a continuous duration greater than its associated IROL T <sub>v</sub> .
R13.	For any sample 24-hour period within the 30-day retention period, the Transmission Operator's Real-time Assessment was not conducted for one 30-minute period within that 24-hour period.	For any sample 24-hour period within the 30-day retention period, the Transmission Operator's Real-time Assessment was not conducted for two 30-minute periods within that 24-hour period.	For any sample 24-hour period within the 30-day retention period, the Transmission Operator's Real-time Assessment was not conducted for three 30-minute periods within that 24-hour period.	For any sample 24-hour period within the 30-day retention period, the Transmission Operator's Real-time Assessment was not conducted for four or more 30-minute periods within that 24-hour period.
R14.	N/A	N/A	N/A	The Transmission Operator did not initiate its Operating

R #	Violation Severity Levels			
	Lower VSL	Moderate VSL	High VSL	Severe VSL
				Plan for mitigating a SOL exceedance identified as part of its Real-time monitoring or Real-time Assessment
R15.	N/A	N/A	N/A	The Transmission Operator did not inform in accordance with its Reliability Coordinator's SOL methodology its Reliability Coordinator of actions taken to return the System to within limits when a SOL had been exceeded.
R16.	N/A	N/A	N/A	The Transmission Operator did not provide its System Operators with the authority to approve planned outages and maintenance of its telemetering and control equipment, monitoring and assessment capabilities, and associated communication channels between affected entities.

R #	Violation Severity Levels			
	Lower VSL	Moderate VSL	High VSL	Severe VSL
<b>R17.</b>	N/A	N/A	N/A	The Balancing Authority did not provide its System Operators with the authority to approve planned outages and maintenance of its telemetering and control equipment, monitoring and assessment capabilities, and associated communication channels between affected entities.
<b>R18.</b>	N/A	N/A	N/A	The Transmission Operator failed to operate to the most limiting parameter in instances where there was a difference in SOLs.
<b>R19.</b> Reserved.				
<b>R20.</b>	N/A	N/A	The Transmission Operator had data exchange capabilities with its Reliability Coordinator, Balancing Authority, and identified entities for performing Real-time	The Transmission Operator did not have data exchange capabilities with its Reliability Coordinator, Balancing Authority, and identified entities for performing Real-time

R #	Violation Severity Levels			
	Lower VSL	Moderate VSL	High VSL	Severe VSL
			monitoring and Real-time Assessments, but did not have redundant and diversely routed data exchange infrastructure within the Transmission Operator's primary Control Center, as specified in the Requirement.	monitoring and Real-time Assessments as specified in the Requirement.
<b>R21.</b>	<p>The Transmission Operator tested its primary Control Center data exchange capabilities specified in Requirement R20 for redundant functionality, but did so more than 90 calendar days but less than or equal to 120 calendar days since the previous test;</p> <p>OR</p> <p>The Transmission Operator tested its primary Control Center data exchange capabilities specified in Requirement</p>	<p>The Transmission Operator tested its primary Control Center data exchange capabilities specified in Requirement R20 for redundant functionality, but did so more than 120 calendar days but less than or equal to 150 calendar days since the previous test;</p> <p>OR</p> <p>The Transmission Operator tested its primary Control Center data exchange capabilities specified in Requirement R20 for redundant functionality at least once every 90 calendar</p>	<p>The Transmission Operator tested its primary Control Center data exchange capabilities specified in Requirement R20 for redundant functionality, but did so more than 150 calendar days but less than or equal to 180 calendar days since the previous test;</p> <p>OR</p> <p>The Transmission Operator tested its primary Control Center data exchange capabilities specified in Requirement R20 for redundant functionality at least once every 90 calendar</p>	<p>The Transmission Operator tested its primary Control Center data exchange capabilities specified in Requirement R20 for redundant functionality, but did so more than 180 calendar days since the previous test;</p> <p>OR</p> <p>The Transmission Operator did not test its primary Control Center data exchange capabilities specified in Requirement R20 for redundant functionality;</p>

R #	Violation Severity Levels			
	Lower VSL	Moderate VSL	High VSL	Severe VSL
	R20 for redundant functionality at least once every 90 calendar days but, following an unsuccessful test, initiated action to restore the redundant functionality in more than 2 hours and less than or equal to 4 hours.	days but, following an unsuccessful test, initiated action to restore the redundant functionality in more than 4 hours and less than or equal to 6 hours.	days but, following an unsuccessful test, initiated action to restore the redundant functionality in more than 6 hours and less than or equal to 8 hours.	OR The Transmission Operator tested its primary Control Center data exchange capabilities specified in Requirement R20 for redundant functionality at least once every 90 calendar days but, following an unsuccessful test, did not initiate action within 8 hours to restore the redundant functionality.
<b>R22.</b> Reserved.				
<b>R23.</b>	N/A	N/A	The Balancing Authority had data exchange capabilities with its Reliability Coordinator, Transmission Operator, and identified entities for performing Real-time monitoring and analysis functions, but did not have redundant and diversely routed data exchange infrastructure	The Balancing Authority did not have data exchange capabilities with its Reliability Coordinator, Transmission Operator, and identified entities for performing Real-time monitoring and analysis functions as specified in the Requirement.

R #	Violation Severity Levels			
	Lower VSL	Moderate VSL	High VSL	Severe VSL
			within the Balancing Authority's primary Control Center, as specified in the Requirement.	
<b>R24.</b>	<p>The Balancing Authority tested its primary Control Center data exchange capabilities specified in Requirement R23 for redundant functionality, but did so more than 90 calendar days but less than or equal to 120 calendar days since the previous test;</p> <p>OR</p> <p>The Balancing Authority tested its primary Control Center data exchange capabilities specified in Requirement R23 for redundant functionality at least once every 90 calendar days but, following an unsuccessful test, initiated action to restore the redundant</p>	<p>The Balancing Authority tested its primary Control Center data exchange capabilities specified in Requirement R23 for redundant functionality, but did so more than 120 calendar days but less than or equal to 150 calendar days since the previous test;</p> <p>OR</p> <p>The Balancing Authority tested its primary Control Center data exchange capabilities specified in Requirement R23 for redundant functionality at least once every 90 calendar days but, following an unsuccessful test, initiated action to restore the redundant functionality in</p>	<p>The Balancing Authority tested its primary Control Center data exchange capabilities specified in Requirement R23 for redundant functionality, but did so more than 150 calendar days but less than or equal to 180 calendar days since the previous test;</p> <p>OR</p> <p>The Balancing Authority tested its primary Control Center data exchange capabilities specified in Requirement R23 for redundant functionality at least once every 90 calendar days but, following an unsuccessful test, initiated action to restore the redundant functionality in</p>	<p>The Balancing Authority tested its primary Control Center data exchange capabilities specified in Requirement R23 for redundant functionality, but did so more than 180 calendar days since the previous test;</p> <p>OR</p> <p>The Balancing Authority did not test its primary Control Center data exchange capabilities specified in Requirement R23 for redundant functionality;</p> <p>OR</p> <p>The Balancing Authority tested its primary Control Center data exchange capabilities specified in</p>

R #	Violation Severity Levels			
	Lower VSL	Moderate VSL	High VSL	Severe VSL
	functionality in more than 2 hours and less than or equal to 4 hours.	more than 4 hours and less than or equal to 6 hours.	more than 6 hours and less than or equal to 8 hours.	Requirement R23 for redundant functionality at least once every 90 calendar days but, following an unsuccessful test, did not initiate action within 8 hours to restore the redundant functionality.
R25.				The Transmission Operator failed to use the applicable Reliability Coordinator's SOL methodology when determining SOL exceedances for Real-time Assessments, Real-time monitoring, and Operational Planning Analysis.

## D. Regional Variances

None.

## E. Associated Documents

The Project 2014-03 SDT has created the SOL Exceedance White Paper as guidance on SOL issues and the URL for that document is: <http://www.nerc.com/pa/stand/Pages/TOP0013RI.aspx>.

Operating Plan - An Operating Plan includes general Operating Processes and specific Operating Procedures. It may be an overview document which provides a prescription for an Operating Plan for the next-day, or it may be a specific plan to address a specific SOL or IROL exceedance identified in the Operational Planning Analysis (OPA). Consistent with the NERC definition, Operating Plans can be general in nature, or they can be specific plans to address specific reliability issues. The use of the term Operating Plan in the revised TOP/IRO standards allows room for both. An Operating Plan references processes and procedures, including electronic data exchange, which are available to the System Operator on a daily basis to allow the operator to reliably address conditions which may arise throughout the day. It is valid for tomorrow, the day after, and the day after that. Operating Plans should be augmented by temporary operating guides which outline prevention/mitigation plans for specific situations which are identified day-to-day in an OPA or a Real-time Assessment (RTA). As the definition in the Glossary of Terms states, a restoration plan is an example of an Operating Plan. It contains all the overarching principles that the System Operator needs to work his/her way through the restoration process. It is not a specific document written for a specific blackout scenario but rather a collection of tools consisting of processes, procedures, and automated software systems that are available to the operator to use in restoring the system. An Operating Plan can in turn be looked upon in a similar manner. It does not contain a prescription for the specific set-up for tomorrow but contains a treatment of all the processes, procedures, and automated software systems that are at the operator's disposal. The existence of an Operating Plan, however, does not preclude the need for creating specific action plans for specific SOL or IROL exceedances identified in the OPA. When a Reliability Coordinator performs an OPA, the analysis may reveal instances of possible SOL or IROL exceedances for pre- or post-Contingency conditions. In these instances, Reliability Coordinators are expected to ensure that there are plans in place to prevent or mitigate those SOLs or IROLs, should those operating conditions be encountered the next day. The Operating Plan may contain a description of the process by which specific prevention or mitigation plans for day-to-day SOL or IROL exceedances identified in the OPA are handled and communicated. This approach could alleviate any potential administrative burden associated with perceived requirements for continual day-to-day updating of "the Operating Plan document" for compliance purposes.



## Version History

Version	Date	Action	Change Tracking
0	April 1, 2005	Effective Date	New
0	August 8, 2005	Removed "Proposed" from Effective Date	Errata
1	November 1, 2006	Adopted by Board of Trustees	Revised
1a	May 12, 2010	Added Appendix 1 – Interpretation of R8 approved by Board of Trustees on May 12, 2010	Interpretation
1a	September 15, 2011	FERC Order issued approved the Interpretation of R8 (FERC Order became effective November 21, 2011)	Interpretation
2	May 6, 2012	Revised under Project 2007-03	Revised
2	May 9, 2012	Adopted by Board of Trustees	Revised
3	February 12, 2015	Adopted by Board of Trustees	Revisions under Project 2014-03
3	November 19, 2015	FERC approved TOP-001-3. Docket No. RM15-16-000. Order No. 817.	Approved
4	February 9, 2017	Adopted by Board of Trustees	Revised
4	April 17, 2017	FERC letter Order approved TOP-001-4. Docket No. RD17-4-000	
5	TBD	Adopted by Board of Trustees	R19 and R22 retired under Project 2018-03 Standards Efficiency Review Retirements
6	May 13, 2021	Adopted by the Board of Trustees	Revised under Project 2015-09

## A. Introduction

1. **Title:** \_\_\_\_\_ Transmission Operations
2. **Number:** TOP-001-~~56~~
3. **Purpose:** To prevent instability, uncontrolled separation, or Cascading outages \_\_\_\_\_ that adversely impact the reliability of the Interconnection by ensuring \_\_\_\_\_ prompt action to prevent or mitigate such occurrences.
4. **Applicability:**
  - 4.1. **Functional Entities:**
    - 4.1.1. Balancing Authority
    - 4.1.2. Transmission Operator
    - 4.1.3. Generator Operator
    - 4.1.4. Distribution Provider
5. **Effective Date:** See Implementation Plan

## B. Requirements and Measures

- R1.** Each Transmission Operator shall act to maintain the reliability of its Transmission Operator Area via its own actions or by issuing Operating Instructions. *[Violation Risk Factor: High][Time Horizon: Same-Day Operations, Real-time Operations]*
- M1.** Each Transmission Operator shall have and provide evidence which may include but is not limited to dated operator logs, dated records, dated and time-stamped voice recordings or dated transcripts of voice recordings, electronic communications, or equivalent documentation, that will be used to determine that it acted to maintain the reliability of its Transmission Operator Area via its own actions or by issuing Operating Instructions.
- R2.** Each Balancing Authority shall act to maintain the reliability of its Balancing Authority Area via its own actions or by issuing Operating Instructions. *[Violation Risk Factor: High][Time Horizon: Same-Day Operations, Real-time Operations]*
- M2.** Each Balancing Authority shall have and provide evidence which may include but is not limited to dated operator logs, dated records, dated and time-stamped voice recordings or dated transcripts of voice recordings, electronic communications, or equivalent documentation, that will be used to determine that it acted to maintain the reliability of its Balancing Authority Area via its own actions or by issuing Operating Instructions.
- R3.** Each Balancing Authority, Generator Operator, and Distribution Provider shall comply with each Operating Instruction issued by its Transmission Operator(s), unless such action cannot be physically implemented or it would violate safety, equipment, regulatory, or statutory requirements. *[Violation Risk Factor: High] [Time Horizon: Same-Day Operations, Real-Time Operations]*
- M3.** Each Balancing Authority, Generator Operator, and Distribution Provider shall make available upon request, evidence that it complied with each Operating Instruction issued by the Transmission Operator(s) unless such action could not be physically implemented or it would have violated safety, equipment, regulatory, or statutory requirements. Such evidence could include but is not limited to dated operator logs, voice recordings or transcripts of voice recordings, electronic communications, or other equivalent evidence in electronic or hard copy format. In such cases, the Balancing Authority, Generator Operator, and Distribution Provider shall have and provide copies of the safety, equipment, regulatory, or statutory requirements as evidence for not complying with the Transmission Operator's Operating Instruction. If such a situation has not occurred, the Balancing Authority, Generator Operator, or Distribution Provider may provide an attestation.
- R4.** Each Balancing Authority, Generator Operator, and Distribution Provider shall inform its Transmission Operator of its inability to comply with an Operating Instruction issued by its Transmission Operator. *[Violation Risk Factor: High] [Time Horizon: Same-Day Operations, Real-Time Operations]*

- M4.** Each Balancing Authority, Generator Operator, and Distribution Provider shall make available upon request, evidence which may include but is not limited to dated operator logs, voice recordings or transcripts of voice recordings, electronic communications, or equivalent evidence in electronic or hard copy format, that it informed its Transmission Operator of its inability to comply with its Operating Instruction issued. If such a situation has not occurred, the Balancing Authority, Generator Operator, or Distribution Provider may provide an attestation.
- R5.** Each Transmission Operator, Generator Operator, and Distribution Provider shall comply with each Operating Instruction issued by its Balancing Authority, unless such action cannot be physically implemented or it would violate safety, equipment, regulatory, or statutory requirements. *[Violation Risk Factor: High] [Time Horizon: Same-Day Operations, Real-Time Operations]*
- M5.** Each Transmission Operator, Generator Operator, and Distribution Provider shall make available upon request, evidence that it complied with each Operating Instruction issued by its Balancing Authority unless such action could not be physically implemented or it would have violated safety, equipment, regulatory, or statutory requirements. Such evidence could include but is not limited to dated operator logs, voice recordings or transcripts of voice recordings, electronic communications, or other equivalent evidence in electronic or hard copy format. In such cases, the Transmission Operator, Generator Operator, and Distribution Provider shall have and provide copies of the safety, equipment, regulatory, or statutory requirements as evidence for not complying with the Balancing Authority's Operating Instruction. If such a situation has not occurred, the Transmission Operator, Generator Operator, or Distribution Provider may provide an attestation.
- R6.** Each Transmission Operator, Generator Operator, and Distribution Provider shall inform its Balancing Authority of its inability to comply with an Operating Instruction issued by its Balancing Authority. *[Violation Risk Factor: High] [Time Horizon: Same-Day Operations, Real-Time Operations]*
- M6.** Each Transmission Operator, Generator Operator, and Distribution Provider shall make available upon request, evidence which may include but is not limited to dated operator logs, voice recordings or transcripts of voice recordings, electronic communications, or equivalent evidence in electronic or hard copy format, that it informed its Balancing Authority of its inability to comply with its Operating Instruction. If such a situation has not occurred, the Transmission Operator, Generator Operator, or Distribution Provider may provide an attestation.
- R7.** Each Transmission Operator shall assist other Transmission Operators within its Reliability Coordinator Area, if requested and able, provided that the requesting Transmission Operator has implemented its comparable Emergency procedures, unless such assistance cannot be physically implemented or would violate safety, equipment, regulatory, or statutory requirements. *[Violation Risk Factor: High] [Time Horizon: Real-Time Operations]*

- M7.** Each Transmission Operator shall make available upon request, evidence that comparable requested assistance, if able, was provided to other Transmission Operators within its Reliability Coordinator Area unless such assistance could not be physically implemented or would have violated safety, equipment, regulatory, or statutory requirements. Such evidence could include but is not limited to dated operator logs, voice recordings or transcripts of voice recordings, electronic communications, or other equivalent evidence in electronic or hard copy format. If no request for assistance was received, the Transmission Operator may provide an attestation.
- R8.** Each Transmission Operator shall inform its Reliability Coordinator, known impacted Balancing Authorities, and known impacted Transmission Operators of its actual or expected operations that result in, or could result in, an Emergency. *[Violation Risk Factor: High] [Time Horizon: Operations Planning, Same-Day Operations, Real-Time Operations]*
- M8.** Each Transmission Operator shall make available upon request, evidence that it informed its Reliability Coordinator, known impacted Balancing Authorities, and known impacted Transmission Operators of its actual or expected operations that result in, or could result in, an Emergency. Such evidence could include but is not limited to dated operator logs, voice recordings or transcripts of voice recordings, electronic communications, or other equivalent evidence. If no such situations have occurred, the Transmission Operator may provide an attestation.
- R9.** Each Balancing Authority and Transmission Operator shall notify its Reliability Coordinator and known impacted interconnected entities of all planned outages, and unplanned outages of 30 minutes or more, for telemetering and control equipment, monitoring and assessment capabilities, and associated communication channels between the affected entities. *[Violation Risk Factor: Medium] [Time Horizon: Operations Planning, Same-Day Operations, Real-Time Operations]*
- M9.** Each Balancing Authority and Transmission Operator shall make available upon request, evidence that it notified its Reliability Coordinator and known impacted interconnected entities of all planned outages, and unplanned outages of 30 minutes or more, for telemetering and control equipment, monitoring and assessment capabilities, and associated communication channels. Such evidence could include but is not limited to dated operator logs, voice recordings or transcripts of voice recordings, electronic communications, or other equivalent evidence. If such a situation has not occurred, the Balancing Authority or Transmission Operator may provide an attestation.
- R10.** Each Transmission Operator shall perform the following for determining System Operating Limit (SOL) exceedances within its Transmission Operator Area: *[Violation Risk Factor: High] [Time Horizon: Real-Time Operations]*
- 10.1.** Monitor Facilities within its Transmission Operator Area;

- 10.2.** Monitor the status of Remedial Action Schemes within its Transmission Operator Area;
  - 10.3.** Monitor non-BES facilities within its Transmission Operator Area identified as necessary by the Transmission Operator;
  - 10.4.** Obtain and utilize status, voltages, and flow data for Facilities outside its Transmission Operator Area identified as necessary by the Transmission Operator;
  - 10.5.** Obtain and utilize the status of Remedial Action Schemes outside its Transmission Operator Area identified as necessary by the Transmission Operator; and
  - 10.6.** Obtain and utilize status, voltages, and flow data for non-BES facilities outside its Transmission Operator Area identified as necessary by the Transmission Operator.
- M10.** Each Transmission Operator shall have, and provide upon request, evidence that could include but is not limited to Energy Management System description documents, computer printouts, Supervisory Control and Data Acquisition (SCADA) data collection, or other equivalent evidence that will be used to confirm that it monitored or obtained and utilized data as required to determine any System Operating Limit (SOL) exceedances within its Transmission Operator Area.
- R11.** Each Balancing Authority shall monitor its Balancing Authority Area, including the status of Remedial Action Schemes that impact generation or Load, in order to maintain generation-Load-interchange balance within its Balancing Authority Area and support Interconnection frequency. *[Violation Risk Factor: High] [Time Horizon: Real-Time Operations]*
- M11.** Each Balancing Authority shall have, and provide upon request, evidence that could include but is not limited to Energy Management System description documents, computer printouts, SCADA data collection, or other equivalent evidence that will be used to confirm that it monitors its Balancing Authority Area, including the status of Remedial Action Schemes that impact generation or Load, in order to maintain generation-Load-interchange balance within its Balancing Authority Area and support Interconnection frequency.
- R12.** Each Transmission Operator shall not operate outside any identified Interconnection Reliability Operating Limit (IROL) for a continuous duration exceeding its associated IROL T<sub>v</sub>. *[Violation Risk Factor: High] [Time Horizon: Real-time Operations]*
- M12.** Each Transmission Operator shall make available evidence to show that for any occasion in which it operated outside any identified Interconnection Reliability Operating Limit (IROL), the continuous duration did not exceed its associated IROL T<sub>v</sub>. Such evidence could include but is not limited to dated computer logs or reports in electronic or hard copy format specifying the date, time, duration, and details of the

excursion. If such a situation has not occurred, the Transmission Operator may provide an attestation that an event has not occurred.

- R13.** Each Transmission Operator shall ensure that a Real-time Assessment is performed at least once every 30 minutes. *[Violation Risk Factor: High] [Time Horizon: Real-time Operations]*
- M13.** Each Transmission Operator shall have, and make available upon request, evidence to show it ensured that a Real-Time Assessment was performed at least once every 30 minutes. This evidence could include but is not limited to dated computer logs showing times the assessment was conducted, dated checklists, or other evidence.
- R14.** Each Transmission Operator shall initiate its Operating Plan to mitigate a SOL exceedance identified as part of its Real-time monitoring or Real-time Assessment. *[Violation Risk Factor: High] [Time Horizon: Real-time Operations]*
- M14.** Each Transmission Operator shall have evidence that it initiated its Operating Plan for mitigating SOL exceedances identified as part of its Real-time monitoring or Real-time Assessments. This evidence could include but is not limited to dated computer logs showing times the Operating Plan was initiated, dated checklists, or other evidence. Other evidence could include but is not limited to: Reliability Coordinator's SOL methodology, system logs/records showing successfully mitigated SOL exceedances in conjunction with Operating Plans (e.g. mutually agreed operating protocols between TOPs and their Reliability Coordinator, Operating Procedures, Operating Processes, operating policies, generator redispatch logs, equipment settings for automatically switched equipment and reactive power/voltage control devices, switching schedules, etc.).
- R15.** Each Transmission Operator shall inform its Reliability Coordinator of actions taken to return the System to within limits when a SOL has been exceeded in accordance with its Reliability Coordinator's SOL methodology. *[Violation Risk Factor: Medium] [Time Horizon: Real-Time Operations]*
- M15.** Each Transmission Operator shall make available evidence that it informed its Reliability Coordinator of actions taken to return the System to within limits when a SOL was exceeded in accordance with its Reliability Coordinator's SOL methodology. Such evidence could include but is not limited to dated operator logs, electronic communications, voice recordings or transcripts of voice recordings, or dated computer printouts. If such a situation has not occurred, the Transmission Operator may provide an attestation.
- R16.** Each Transmission Operator shall provide its System Operators with the authority to approve planned outages and maintenance of its telemetering and control equipment, monitoring and assessment capabilities, and associated communication channels between affected entities. *[Violation Risk Factor: High] [Time Horizon: Operations Planning, Same-Day Operations, Real-time Operations]*

- M16.** Each Transmission Operator shall have, and provide upon request, evidence that could include but is not limited to a documented procedure or equivalent evidence that will be used to confirm that the Transmission Operator has provided its System Operators with the authority to approve planned outages and maintenance of telemetering and control equipment, monitoring and assessment capabilities, and associated communication channels between affected entities.
- R17.** Each Balancing Authority shall provide its System Operators with the authority to approve planned outages and maintenance of its telemetering and control equipment, monitoring and assessment capabilities, and associated communication channels between affected entities. *[Violation Risk Factor: High] [Time Horizon: Operations Planning, Same-Day Operations, Real-time Operations]*
- M17.** Each Balancing Authority shall have, and provide upon request, evidence that could include but is not limited to a documented procedure or equivalent evidence that will be used to confirm that the Balancing Authority has provided its System Operators with the authority to approve planned outages and maintenance of its telemetering and control equipment, monitoring and assessment capabilities, and associated communication channels between affected entities.
- R18.** Each Transmission Operator shall operate to the most limiting parameter in instances where there is a difference in SOLs. *[Violation Risk Factor: High] [Time Horizon: Operations Planning, Same-Day Operations, Real-time Operations]*
- M18.** Each Transmission Operator shall have, and provide upon request, evidence that could include but is not limited to operator logs, voice recordings, electronic communications, or equivalent evidence that will be used to determine if it operated to the most limiting parameter in instances where there is a difference in SOLs.
- R19.** Reserved.
- M19.** Reserved.
- R20.** Each Transmission Operator shall have data exchange capabilities, with redundant and diversely routed data exchange infrastructure within the Transmission Operator's primary Control Center, for the exchange of Real-time data with its Reliability Coordinator, Balancing Authority, and the entities it has identified it needs data from in order for it to perform its Real-time monitoring and Real-time Assessments. *[Violation Risk Factor: High] [Time Horizon: Same-Day Operations, Real-time Operations]*
- M20.** Each Transmission Operator shall have, and provide upon request, evidence that could include, but is not limited to, system specifications, system diagrams, or other documentation that lists its data exchange capabilities, including redundant and diversely routed data exchange infrastructure within the Transmission Operator's primary Control Center, for the exchange of Real-time data with its Reliability Coordinator, Balancing Authority, and the entities it has identified it needs data from



in order to perform its Real-time monitoring and Real-time Assessments as specified in the requirement.

- R21.** Each Transmission Operator shall test its primary Control Center data exchange capabilities specified in Requirement R20 for redundant functionality at least once every 90 calendar days. If the test is unsuccessful, the Transmission Operator shall initiate action within two hours to restore redundant functionality. *[Violation Risk Factor: Medium ] [Time Horizon: Operations Planning]*
- M21.** Each Transmission Operator shall have, and provide upon request, evidence that it tested its primary Control Center data exchange capabilities specified in Requirement R20 for the redundant functionality, or experienced an event that demonstrated the redundant functionality; and, if the test was unsuccessful, initiated action within two hours to restore redundant functionality as specified in Requirement R21. Evidence could include, but is not limited to: dated and time-stamped test records, operator logs, voice recordings, or electronic communications.
- R22.** Reserved.
- M22.** Reserved.
- R23.** Each Balancing Authority shall have data exchange capabilities, with redundant and diversely routed data exchange infrastructure within the Balancing Authority's primary Control Center, for the exchange of Real-time data with its Reliability Coordinator, Transmission Operator, and the entities it has identified it needs data from in order for it to perform its Real-time monitoring and analysis functions. *[Violation Risk Factor: High] [Time Horizon: Same-Day Operations, Real-time Operations]*
- M23.** Each Balancing Authority shall have, and provide upon request, evidence that could include, but is not limited to, system specifications, system diagrams, or other documentation that lists its data exchange capabilities, including redundant and diversely routed data exchange infrastructure within the Balancing Authority's primary Control Center, for the exchange of Real-time data with its Reliability Coordinator, Transmission Operator, and the entities it has identified it needs data from in order to perform its Real-time monitoring and analysis functions as specified in the requirement.
- R24.** Each Balancing Authority shall test its primary Control Center data exchange capabilities specified in Requirement R23 for redundant functionality at least once every 90 calendar days. If the test is unsuccessful, the Balancing Authority shall initiate action within two hours to restore redundant functionality. *[Violation Risk Factor: Medium ] [Time Horizon: Operations Planning]*
- M24.** Each Balancing Authority shall have, and provide upon request, evidence that it tested its primary Control Center data exchange capabilities specified in Requirement R23 for redundant functionality, or experienced an event that demonstrated the redundant functionality; and, if the test was unsuccessful, initiated

action within two hours to restore redundant functionality as specified in Requirement R24. Evidence could include, but is not limited to: dated and time-stamped test records, operator logs, voice recordings, or electronic communications.

**R25.** Each Transmission Operator shall use the applicable Reliability Coordinator's SOL methodology when determining SOL exceedances for Real-time Assessments, Real-time monitoring, and Operational Planning Analysis. [Violation Risk Factor: High] [Time Horizon: Same-Day Operations, Real-time Operations, Operations Planning]

**M25.** Each Transmission Operator shall have, and provide upon request, evidence that it used the applicable Reliability Coordinator's SOL methodology when determining SOL exceedances for Real-time Assessments, Real-time monitoring, and Operational Planning Analysis. Evidence could include, but is not limited to: Reliability Coordinator's SOL methodology, Operating Plans, contingency sets, alarming and study reporting thresholds, operator logs, voice recordings or other equivalent evidence.

## C. Compliance

### 1. Compliance Monitoring Process

#### 1.1. Compliance Enforcement Authority:

“Compliance Enforcement Authority” means NERC or the Regional Entity, or any entity as otherwise designated by an Applicable Governmental Authority, in their respective roles of monitoring and/or enforcing compliance with mandatory and enforceable Reliability Standards in their respective jurisdictions.

#### 1.2. Evidence Retention:

The following evidence retention period(s) identify the period of time an entity is required to retain specific evidence to demonstrate compliance. For instances where the evidence retention period specified below is shorter than the time since the last audit, the Compliance Enforcement Authority may ask an entity to provide other evidence to show that it was compliant for the full-time period since the last audit.

The applicable entity shall keep data or evidence to show compliance as identified below unless directed by its Compliance Enforcement Authority to retain specific evidence for a longer period of time as part of an investigation.

- Each Balancing Authority, Transmission Operator, Generator Operator, and Distribution Provider shall each keep data or evidence for each applicable Requirement R1 through R11, and Measure M1 through M11, for the current calendar year and one previous calendar year, with the exception of operator logs and voice recordings which shall be retained for a minimum of 90 calendar days, unless directed by its Compliance Enforcement Authority to retain specific evidence for a longer period of time as part of an investigation.
- Each Transmission Operator shall retain evidence for three calendar years of any occasion in which it has exceeded an identified IROL and its associated IROL  $T_v$  as specified in Requirement R12 and Measure M12.
- Each Transmission Operator shall keep data or evidence for Requirement R13 and Measure M13 for a rolling 30-day period, unless directed by its Compliance Enforcement Authority to retain specific evidence for a longer period of time as part of an investigation.
- Each Transmission Operator shall retain evidence and that it initiated its Operating Plan to mitigate a SOL exceedance as specified in Requirement R14 and Measurement M14 ~~for three calendar years~~rolling for rolling 12 months.
- Each Transmission Operator and Balancing Authority shall each keep data or evidence for each applicable Requirement R15 through R18, and Measure M15 through M18 for the current calendar year and one

previous calendar year, with the exception of operator logs and voice recordings which shall be retained for a minimum of 90 calendar days.

- Each Transmission Operator shall keep data or evidence for Requirement R20 and Measure M20 for the current calendar year and one previous calendar year.
- Each Transmission Operator shall keep evidence for Requirement R21 and Measure M21 for the most recent twelve calendar months, with the exception of operator logs and voice recordings which shall be retained for a minimum of 90 calendar days.
- Each Balancing Authority shall keep data or evidence for Requirement R23 and Measure M23 for the current calendar year and one previous calendar year.
- Each Balancing Authority shall keep evidence for Requirement R24 and Measure M24 for the most recent twelve calendar months, with the exception of operator logs and voice recordings which shall be retained for a minimum of 90 calendar days.
- Each Transmission Operator shall retain evidence that it used the applicable Reliability Coordinator’s SOL methodology when determining SOL exceedances for Real-time Assessments, Real-time monitoring, and Operational Planning Analysis as specified in Requirement R25 and Measurement M25 for a rolling 12 months.

**1.4.1.3. Compliance Monitoring and Enforcement Program**

As defined in the NERC Rules of Procedure, “Compliance Monitoring and Enforcement Program” refers to the identification of the processes that will be used to evaluate data or information for the purpose of assessing performance or outcomes with the associated Reliability Standard.

### Violation Severity Levels

R #	Violation Severity Levels			
	Lower VSL	Moderate VSL	High VSL	Severe VSL
R1.	N/A	N/A	N/A	The Transmission Operator failed to act to maintain the reliability of its Transmission Operator Area via its own actions or by issuing Operating Instructions.
R2.	N/A	N/A	N/A	The Balancing Authority failed to act to maintain the reliability of its Balancing Authority Area via its own actions or by issuing Operating Instructions.
R3.	N/A	N/A	N/A	The responsible entity did not comply with an Operating Instruction issued by the Transmission Operator, and such action could have been physically implemented and would not have violated safety, equipment, regulatory, or statutory requirements.
R4.	N/A	N/A	N/A	The responsible entity did not inform its Transmission Operator of its inability to

R #	Violation Severity Levels			
	Lower VSL	Moderate VSL	High VSL	Severe VSL
				comply with an Operating Instruction issued by its Transmission Operator.
R5.	N/A	N/A	N/A	The responsible entity did not comply with an Operating Instruction issued by the Balancing Authority, and such action could have been physically implemented and would not have violated safety, equipment, regulatory, or statutory requirements.
R6.	N/A	N/A	N/A	The responsible entity did not inform its Balancing Authority of its inability to comply with an Operating Instruction issued by its Balancing Authority.
R7.	N/A	N/A	N/A	The Transmission Operator did not provide comparable assistance to other Transmission Operators within its Reliability Coordinator Area, when requested and able, and the

R #	Violation Severity Levels			
	Lower VSL	Moderate VSL	High VSL	Severe VSL
				requesting entity had implemented its Emergency procedures, and such actions could have been physically implemented and would not have violated safety, equipment, regulatory, or statutory requirements.
<b>R8.</b>	<p>The Transmission Operator did not inform one known impacted Transmission Operator or 5% or less of the known impacted Transmission Operators, whichever is greater, of its actual or expected operations that resulted in, or could have resulted in, an Emergency on respective Transmission Operator Areas.</p> <p>OR,</p> <p>The Transmission Operator did not inform one known impacted</p>	<p>The Transmission Operator did not inform two known impacted Transmission Operators or more than 5% and less than or equal to 10% of the known impacted Transmission Operators, whichever is greater, of its actual or expected operations that resulted in, or could have resulted in, an Emergency on respective Transmission Operator Areas.</p> <p>OR,</p> <p>The Transmission Operator did not inform two known impacted Balancing</p>	<p>The Transmission Operator did not inform three known impacted Transmission Operators or more than 10% and less than or equal to 15% of the known impacted Transmission Operators, whichever is greater, of its actual or expected operations that resulted in, or could have resulted in, an Emergency on respective Transmission Operator Areas.</p> <p>OR,</p> <p>The Transmission Operator did not inform three known impacted Balancing</p>	<p>The Transmission Operator did not inform its Reliability Coordinator of its actual or expected operations that resulted in, or could have resulted in, an Emergency on those respective Transmission Operator Areas.</p> <p>OR</p> <p>The Transmission Operator did not inform four or more known impacted Transmission Operators or more than 15% of the known impacted Transmission Operators of its actual or expected</p>

R #	Violation Severity Levels			
	Lower VSL	Moderate VSL	High VSL	Severe VSL
	Balancing Authorities or 5% or less of the known impacted Balancing Authorities, whichever is greater, of its actual or expected operations that resulted in, or could have resulted in, an Emergency on respective Balancing Authority Areas.	Authorities or more than 5% and less than or equal to 10% of the known impacted Balancing Authorities, whichever is greater, of its actual or expected operations that resulted in, or could have resulted in, an Emergency on respective Balancing Authority Areas.	Authorities or more than 10% and less than or equal to 15% of the known impacted Balancing Authorities, whichever is greater, of its actual or expected operations that resulted in, or could have resulted in, an Emergency on respective Balancing Authority Areas.	operations that resulted in, or could have resulted in, an Emergency on those respective Transmission Operator Areas. OR, The Transmission Operator did not inform four or more known impacted Balancing Authorities or more than 15% of the known impacted Balancing Authorities of its actual or expected operations that resulted in, or could have resulted in, an Emergency on respective Balancing Authority Areas.
R9.	The responsible entity did not notify one known impacted interconnected entity or 5% or less of the known impacted entities, whichever is greater, of a planned outage, or an unplanned outage of 30 minutes or more, for telemetering and control	The responsible entity did not notify two known impacted interconnected entities or more than 5% and less than or equal to 10% of the known impacted entities, whichever is greater, of a planned outage, or an unplanned outage of 30	The responsible entity did not notify three known impacted interconnected entities or more than 10% and less than or equal to 15% of the known impacted entities, whichever is greater, of a planned outage, or an unplanned outage of 30	The responsible entity did not notify its Reliability Coordinator of a planned outage, or an unplanned outage of 30 minutes or more, for telemetering and control equipment, monitoring and assessment capabilities, and associated communication channels.



R #	Violation Severity Levels			
	Lower VSL	Moderate VSL	High VSL	Severe VSL
	equipment, monitoring and assessment capabilities, or associated communication channels between the affected entities.	minutes or more, for telemetering and control equipment, monitoring and assessment capabilities, or associated communication channels between the affected entities.	minutes or more, for telemetering and control equipment, monitoring and assessment capabilities, or associated communication channels between the affected entities.	OR, The responsible entity did not notify four or more known impacted interconnected entities or more than 15% of the known impacted entities, whichever is greater, of a planned outage, or an unplanned outage of 30 minutes or more, for telemetering and control equipment, monitoring and assessment capabilities, or associated communication channels between the affected entities.
<b>R10.</b>	The Transmission Operator did not monitor, obtain, or utilize one of the items required or identified as necessary by the Transmission Operator and listed in Requirement R10, Part 10.1 through 10.6.	The Transmission Operator did not monitor, obtain, or utilize two of the items required or identified as necessary by the Transmission Operator and listed in Requirement R10, Part 10.1 through 10.6.	The Transmission Operator did not monitor, obtain, or utilize three of the items required or identified as necessary by the Transmission Operator and listed in Requirement R10, Part 10.1 through 10.6.	The Transmission Operator did not monitor, obtain, or utilize four or more of the items required or identified as necessary by the Transmission Operator and listed in Requirement R10 Part 10.1 through 10.6.

R #	Violation Severity Levels			
	Lower VSL	Moderate VSL	High VSL	Severe VSL
R11.	N/A	N/A	The Balancing Authority did not monitor the status of Remedial Action Schemes that impact generation or Load, in order to maintain generation-Load-interchange balance within its Balancing Authority Area and support Interconnection frequency.	The Balancing Authority did not monitor its Balancing Authority Area, in order to maintain generation-Load-interchange balance within its Balancing Authority Area and support Interconnection frequency.
R12.	N/A	N/A	N/A	The Transmission Operator exceeded an identified Interconnection Reliability Operating Limit (IROL) for a continuous duration greater than its associated IROL T <sub>v</sub> .
R13.	For any sample 24-hour period within the 30-day retention period, the Transmission Operator's Real-time Assessment was not conducted for one 30-minute period within that 24-hour period.	For any sample 24-hour period within the 30-day retention period, the Transmission Operator's Real-time Assessment was not conducted for two 30-minute periods within that 24-hour period.	For any sample 24-hour period within the 30-day retention period, the Transmission Operator's Real-time Assessment was not conducted for three 30-minute periods within that 24-hour period.	For any sample 24-hour period within the 30-day retention period, the Transmission Operator's Real-time Assessment was not conducted for four or more 30-minute periods within that 24-hour period.
R14.	N/A	N/A	N/A	The Transmission Operator did not initiate its Operating

R #	Violation Severity Levels			
	Lower VSL	Moderate VSL	High VSL	Severe VSL
				Plan for mitigating a SOL exceedance identified as part of its Real-time monitoring or Real-time Assessment
R15.	N/A	N/A	N/A	The Transmission Operator did not inform <a href="#">in accordance with its Reliability Coordinator's SOL methodology</a> its Reliability Coordinator of actions taken to return the System to within limits when a SOL had been exceeded.
R16.	N/A	N/A	N/A	The Transmission Operator did not provide its System Operators with the authority to approve planned outages and maintenance of its telemetering and control equipment, monitoring and assessment capabilities, and associated communication channels between affected entities.

R #	Violation Severity Levels			
	Lower VSL	Moderate VSL	High VSL	Severe VSL
R17.	N/A	N/A	N/A	The Balancing Authority did not provide its System Operators with the authority to approve planned outages and maintenance of its telemetering and control equipment, monitoring and assessment capabilities, and associated communication channels between affected entities.
R18.	N/A	N/A	N/A	The Transmission Operator failed to operate to the most limiting parameter in instances where there was a difference in SOLs.
R19. Reserved.				
R20.	N/A	N/A	The Transmission Operator had data exchange capabilities with its Reliability Coordinator, Balancing Authority, and identified entities for performing Real-time	The Transmission Operator did not have data exchange capabilities with its Reliability Coordinator, Balancing Authority, and identified entities for performing Real-time

R #	Violation Severity Levels			
	Lower VSL	Moderate VSL	High VSL	Severe VSL
			monitoring and Real-time Assessments, but did not have redundant and diversely routed data exchange infrastructure within the Transmission Operator's primary Control Center, as specified in the Requirement.	monitoring and Real-time Assessments as specified in the Requirement.
<b>R21.</b>	<p>The Transmission Operator tested its primary Control Center data exchange capabilities specified in Requirement R20 for redundant functionality, but did so more than 90 calendar days but less than or equal to 120 calendar days since the previous test;</p> <p>OR</p> <p>The Transmission Operator tested its primary Control Center data exchange capabilities specified in Requirement</p>	<p>The Transmission Operator tested its primary Control Center data exchange capabilities specified in Requirement R20 for redundant functionality, but did so more than 120 calendar days but less than or equal to 150 calendar days since the previous test;</p> <p>OR</p> <p>The Transmission Operator tested its primary Control Center data exchange capabilities specified in Requirement R20 for redundant functionality at least once every 90 calendar</p>	<p>The Transmission Operator tested its primary Control Center data exchange capabilities specified in Requirement R20 for redundant functionality, but did so more than 150 calendar days but less than or equal to 180 calendar days since the previous test;</p> <p>OR</p> <p>The Transmission Operator tested its primary Control Center data exchange capabilities specified in Requirement R20 for redundant functionality at least once every 90 calendar</p>	<p>The Transmission Operator tested its primary Control Center data exchange capabilities specified in Requirement R20 for redundant functionality, but did so more than 180 calendar days since the previous test;</p> <p>OR</p> <p>The Transmission Operator did not test its primary Control Center data exchange capabilities specified in Requirement R20 for redundant functionality;</p>

R #	Violation Severity Levels			
	Lower VSL	Moderate VSL	High VSL	Severe VSL
	R20 for redundant functionality at least once every 90 calendar days but, following an unsuccessful test, initiated action to restore the redundant functionality in more than 2 hours and less than or equal to 4 hours.	days but, following an unsuccessful test, initiated action to restore the redundant functionality in more than 4 hours and less than or equal to 6 hours.	days but, following an unsuccessful test, initiated action to restore the redundant functionality in more than 6 hours and less than or equal to 8 hours.	OR The Transmission Operator tested its primary Control Center data exchange capabilities specified in Requirement R20 for redundant functionality at least once every 90 calendar days but, following an unsuccessful test, did not initiate action within 8 hours to restore the redundant functionality.
<b>R22.</b> Reserved.				
<b>R23.</b>	N/A	N/A	The Balancing Authority had data exchange capabilities with its Reliability Coordinator, Transmission Operator, and identified entities for performing Real-time monitoring and analysis functions, but did not have redundant and diversely routed data exchange infrastructure	The Balancing Authority did not have data exchange capabilities with its Reliability Coordinator, Transmission Operator, and identified entities for performing Real-time monitoring and analysis functions as specified in the Requirement.

R #	Violation Severity Levels			
	Lower VSL	Moderate VSL	High VSL	Severe VSL
			within the Balancing Authority's primary Control Center, as specified in the Requirement.	
<b>R24.</b>	<p>The Balancing Authority tested its primary Control Center data exchange capabilities specified in Requirement R23 for redundant functionality, but did so more than 90 calendar days but less than or equal to 120 calendar days since the previous test;</p> <p>OR</p> <p>The Balancing Authority tested its primary Control Center data exchange capabilities specified in Requirement R23 for redundant functionality at least once every 90 calendar days but, following an unsuccessful test, initiated action to restore the redundant</p>	<p>The Balancing Authority tested its primary Control Center data exchange capabilities specified in Requirement R23 for redundant functionality, but did so more than 120 calendar days but less than or equal to 150 calendar days since the previous test;</p> <p>OR</p> <p>The Balancing Authority tested its primary Control Center data exchange capabilities specified in Requirement R23 for redundant functionality at least once every 90 calendar days but, following an unsuccessful test, initiated action to restore the redundant functionality in</p>	<p>The Balancing Authority tested its primary Control Center data exchange capabilities specified in Requirement R23 for redundant functionality, but did so more than 150 calendar days but less than or equal to 180 calendar days since the previous test;</p> <p>OR</p> <p>The Balancing Authority tested its primary Control Center data exchange capabilities specified in Requirement R23 for redundant functionality at least once every 90 calendar days but, following an unsuccessful test, initiated action to restore the redundant functionality in</p>	<p>The Balancing Authority tested its primary Control Center data exchange capabilities specified in Requirement R23 for redundant functionality, but did so more than 180 calendar days since the previous test;</p> <p>OR</p> <p>The Balancing Authority did not test its primary Control Center data exchange capabilities specified in Requirement R23 for redundant functionality;</p> <p>OR</p> <p>The Balancing Authority tested its primary Control Center data exchange capabilities specified in</p>

R #	Violation Severity Levels			
	Lower VSL	Moderate VSL	High VSL	Severe VSL
	functionality in more than 2 hours and less than or equal to 4 hours.	more than 4 hours and less than or equal to 6 hours.	more than 6 hours and less than or equal to 8 hours.	Requirement R23 for redundant functionality at least once every 90 calendar days but, following an unsuccessful test, did not initiate action within 8 hours to restore the redundant functionality.
<u>R25.</u>				<u>The Transmission Operator failed to use the applicable Reliability Coordinator’s SOL methodology when determining SOL exceedances for Real-time Assessments, Real-time monitoring, and Operational Planning Analysis.</u>



## D. Regional Variances

None.

## E. Associated Documents

The Project 2014-03 SDT has created the SOL Exceedance White Paper as guidance on SOL issues and the URL for that document is: <http://www.nerc.com/pa/stand/Pages/TOP0013RI.aspx>.

Operating Plan - An Operating Plan includes general Operating Processes and specific Operating Procedures. It may be an overview document which provides a prescription for an Operating Plan for the next-day, or it may be a specific plan to address a specific SOL or IROL exceedance identified in the Operational Planning Analysis (OPA). Consistent with the NERC definition, Operating Plans can be general in nature, or they can be specific plans to address specific reliability issues. The use of the term Operating Plan in the revised TOP/IRO standards allows room for both. An Operating Plan references processes and procedures, including electronic data exchange, which are available to the System Operator on a daily basis to allow the operator to reliably address conditions which may arise throughout the day. It is valid for tomorrow, the day after, and the day after that. Operating Plans should be augmented by temporary operating guides which outline prevention/mitigation plans for specific situations which are identified day-to-day in an OPA or a Real-time Assessment (RTA). As the definition in the Glossary of Terms states, a restoration plan is an example of an Operating Plan. It contains all the overarching principles that the System Operator needs to work his/her way through the restoration process. It is not a specific document written for a specific blackout scenario but rather a collection of tools consisting of processes, procedures, and automated software systems that are available to the operator to use in restoring the system. An Operating Plan can in turn be looked upon in a similar manner. It does not contain a prescription for the specific set-up for tomorrow but contains a treatment of all the processes, procedures, and automated software systems that are at the operator's disposal. The existence of an Operating Plan, however, does not preclude the need for creating specific action plans for specific SOL or IROL exceedances identified in the OPA. When a Reliability Coordinator performs an OPA, the analysis may reveal instances of possible SOL or IROL exceedances for pre- or post-Contingency conditions. In these instances, Reliability Coordinators are expected to ensure that there are plans in place to prevent or mitigate those SOLs or IROLs, should those operating conditions be encountered the next day. The Operating Plan may contain a description of the process by which specific prevention or mitigation plans for day-to-day SOL or IROL exceedances identified in the OPA are handled and communicated. This approach could alleviate any potential administrative burden associated with perceived requirements for continual day-to-day updating of "the Operating Plan document" for compliance purposes.

## Version History

Version	Date	Action	Change Tracking
0	April 1, 2005	Effective Date	New
0	August 8, 2005	Removed "Proposed" from Effective Date	Errata
1	November 1, 2006	Adopted by Board of Trustees	Revised
1a	May 12, 2010	Added Appendix 1 – Interpretation of R8 approved by Board of Trustees on May 12, 2010	Interpretation
1a	September 15, 2011	FERC Order issued approved the Interpretation of R8 (FERC Order became effective November 21, 2011)	Interpretation
2	May 6, 2012	Revised under Project 2007-03	Revised
2	May 9, 2012	Adopted by Board of Trustees	Revised
3	February 12, 2015	Adopted by Board of Trustees	Revisions under Project 2014-03
3	November 19, 2015	FERC approved TOP-001-3. Docket No. RM15-16-000. Order No. 817.	Approved
4	February 9, 2017	Adopted by Board of Trustees	Revised
4	April 17, 2017	FERC letter Order approved TOP-001-4. Docket No. RD17-4-000	
5	TBD	Adopted by Board of Trustees	R19 and R22 retired under Project 2018-03 Standards Efficiency Review Retirements
6	May 13, 2021	Adopted by the Board of Trustees	Revised under Project 2015-09

Exhibit A-5

IRO-008-3 (Clean and Redline to Last Approved)

## A. Introduction

1. **Title:** Reliability Coordinator Operational Analyses and Real-time Assessments
2. **Number:** IRO-008-3
3. **Purpose:** Perform analyses and assessments to prevent instability, uncontrolled separation, or Cascading.
4. **Applicability**
  - 4.1. Reliability Coordinator.
5. **Proposed Effective Date:**  
See Implementation Plan.
6. **Background**  
See Project 2014-03 [project page](#).

## B. Requirements and Measures

- R1.** Each Reliability Coordinator shall perform an Operational Planning Analysis that will allow it to assess whether the planned operations for the next-day will exceed System Operating Limits (SOLs) and Interconnection Reliability Operating Limits (IROLs) within its Wide Area. [*Violation Risk Factor: Medium*] [*Time Horizon: Operations Planning*]
- M1.** Each Reliability Coordinator shall have evidence of a completed Operational Planning Analysis. Such evidence could include but is not limited to dated power flow study results.
- R2.** Each Reliability Coordinator shall have a coordinated Operating Plan(s) for next-day operations to address potential System Operating Limit (SOL) and Interconnection Reliability Operating Limit (IROL) exceedances identified as a result of its Operational Planning Analysis as performed in Requirement R1 while considering the Operating Plans for the next-day provided by its Transmission Operators and Balancing Authorities. [*Violation Risk Factor: Medium*] [*Time Horizon: Operations Planning*]
- M2.** Each Reliability Coordinator shall have evidence that it has a coordinated Operating Plan for next-day operations to address potential System Operating Limit (SOL) and Interconnection Reliability Operating Limit (IROL) exceedances identified as a result of the Operational Planning Analysis performed in Requirement R1 while considering the Operating Plans for the next-day provided by its Transmission Operators and Balancing Authorities. Such evidence could include but is not limited to plans for precluding operating in excess of each SOL and IROL that were identified as a result of the Operational Planning Analysis.

- R3.** Each Reliability Coordinator shall notify impacted entities identified in its Operating Plan(s) cited in Requirement R2 as to their role in such plan(s). *[Violation Risk Factor: Medium] [Time Horizon: Operations Planning]*
- M3.** Each Reliability Coordinator shall have evidence that it notified impacted entities identified in its Operating Plan(s) cited in Requirement R2 as to their role in such plan(s). Such evidence could include, but is not limited to, dated operator logs, or e-mail records.
- R4.** Each Reliability Coordinator shall ensure that a Real-time Assessment is performed at least once every 30 minutes. *[Violation Risk Factor: High] [Time Horizon: Same-day Operations, Real-time Operations]*
- M4.** Each Reliability Coordinator shall have, and make available upon request, evidence to show it ensured that a Real-time Assessment is performed at least once every 30 minutes. This evidence could include but is not limited to dated computer logs showing times the assessment was conducted, dated checklists, or other evidence.
- R5.** Each Reliability Coordinator shall notify, in accordance with its SOL methodology, impacted Transmission Operators and Balancing Authorities within its Reliability Coordinator Area, and other impacted Reliability Coordinators as indicated in its Operating Plan, when the results of a Real-time Assessment indicate an actual or expected condition that results in, or could result in, a System Operating Limit (SOL) exceedance or an Interconnection Reliability Operating Limit (IROL) exceedance within its Wide Area. *[Violation Risk Factor: High] [Time Horizon: Same-Day Operations, Real-time Operations]*
- M5.** Each Reliability Coordinator shall make available upon request, evidence that it informed, in accordance with its SOL methodology impacted Transmission Operators and Balancing Authorities within its Reliability Coordinator Area, and other impacted Reliability Coordinators as indicated in its Operating Plan, of its actual or expected operations that result in, or could result in, a System Operating Limit (SOL) exceedance or an Interconnection Reliability Operating Limit (IROL) exceedance within its Wide Area. Such evidence could include but is not limited to dated operator logs, voice recordings or transcripts of voice recordings, electronic communications, or other equivalent evidence. If such a situation has not occurred, the Reliability Coordinator may provide an attestation.
- R6.** Each Reliability Coordinator shall notify, in accordance with SOL methodology, impacted Transmission Operators and Balancing Authorities within its Reliability Coordinator Area, and other impacted Reliability Coordinators as indicated in its Operating Plan, when the System Operating Limit (SOL) exceedance or an Interconnection Reliability Operating Limit (IROL) exceedance identified in Requirement R5 has been prevented or mitigated. *[Violation Risk Factor: Medium] [Time Horizon: Same-Day Operations, Real-time Operations]*

- M6.** Each Reliability Coordinator shall make available upon request, evidence that it informed, in accordance with its SOL methodology impacted Transmission Operators and Balancing Authorities within its Reliability Coordinator Area, and other impacted Reliability Coordinators as indicated in its Operating Plan, when the System Operating Limit (SOL) exceedance or an Interconnection Reliability Operating Limit (IROL) exceedance identified in Requirement R5 has been prevented or mitigated. Such evidence could include but is not limited to dated operator logs, voice recordings or transcripts of voice recordings, electronic communications, or other equivalent evidence. If such a situation has not occurred, the Reliability Coordinator may provide an attestation.
- R7.** Each Reliability Coordinator shall use its SOL methodology when determining SOL exceedances for Real-time Assessments, Real-time monitoring, and Operational Planning Analysis. *[Violation Risk Factor: Medium ] [Time Horizon: Same-Day Operations, Real-time Operations, Operations Planning]*
- M7.** Each Reliability Coordinator shall have, and provide upon request, evidence that it used its SOL methodology for determining SOL exceedances for Real-time Assessments, Real-time monitoring, and Operational Planning Analysis. Evidence could include, but is not limited to: Operating Plans, contingency sets, SOLs, alarming and study reporting thresholds, operator logs, voice recordings or other equivalent evidence.

## **C. Compliance**

### **1. Compliance Monitoring Process**

#### **1.1. Compliance Enforcement Authority**

As defined in the NERC Rules of Procedure, “Compliance Enforcement Authority” (CEA) means NERC or the Regional Entity in their respective roles of monitoring and enforcing compliance with the NERC Reliability Standards.

#### **1.2. Compliance Monitoring and Assessment Processes**

As defined in the NERC Rules of Procedure, “Compliance Monitoring and Assessment Processes” refers to the identification of the processes that will be used to evaluate data or information for the purpose of assessing performance or outcomes with the associated reliability standard.

#### **1.3. Data Retention**

The following evidence retention periods identify the period of time an entity is required to retain specific evidence to demonstrate compliance. For instances where the evidence retention period specified below is shorter than the time since the last audit, the Compliance Enforcement Authority may ask an entity to provide other evidence to show that it was compliant for the full time period since the last audit.

Each Reliability Coordinator shall keep data or evidence to show compliance for Requirements R1 through R3, R5, R6, and R7 and Measures M1 through M3, M5, M6, and M7 for a rolling 90-calendar days period for analyses, the most recent 90-calendar days for voice recordings, and 12 months for operating logs and e-mail records unless directed by its Compliance Enforcement Authority to retain specific evidence for a longer period of time as part of an investigation.

Each Reliability Coordinator shall each keep data or evidence for Requirement R4 and Measure M4 for a rolling 30-calendar day period, unless directed by its Compliance Enforcement Authority to retain specific evidence for a longer period of time as part of an investigation.

If a Reliability Coordinator is found non-compliant, it shall keep information related to the non-compliance until found compliant or the time period specified above, whichever is longer.

The Compliance Enforcement Authority shall keep the last audit records and all requested and submitted subsequent audit records.

#### **1.4. Additional Compliance Information**

None

**Table of Compliance Elements**

R#	Time Horizons	VRF	Violation Severity Levels			
			Lower VSL	Moderate VSL	High VSL	Severe VSL
R1	Operations Planning	Medium	N/A	N/A	N/A	The Reliability Coordinator did not perform an Operational Planning Analysis allowing it to assess whether its planned operations for the next-day within its Wide Area will exceed any of its System Operating Limits (SOLs) and Interconnection Reliability Operating Limits (IROLs).
R2	Operations Planning	Medium	N/A	N/A	N/A	The Reliability Coordinator did not have a coordinated Operating Plan(s) for next-day operations to address potential System Operating Limit (SOL) and Interconnection Reliability Operating Limit (IROL) exceedances identified as a result of its Operational Planning Analysis as performed in Requirement R1 while considering the Operating Plans for the next-day provided by its Transmission Operators and Balancing Authorities.



R#	Time Horizons	VRF	Violation Severity Levels			
			Lower VSL	Moderate VSL	High VSL	Severe VSL
<p>For the Requirement R3 and R5 VSLs, the intent of the SDT is to start with the Severe VSL first and then to work your way to the left until you find the situation that fits. In this manner, the VSL will not be discriminatory by size. If a Reliability Coordinator has just one affected reliability entity to inform, the intent is that that situation would be a Severe violation</p>						
R3	Operations Planning	Medium	The Reliability Coordinator did not notify one impacted entity or 5% or less of the impacted entities whichever is greater identified in its Operating Plan(s) as to their role in that plan(s).	The Reliability Coordinator did not notify two impacted entities or more than 5% and less than or equal to 10% of the impacted entities whichever is greater, identified in its Operating Plan(s) as to their role in that plan(s).	The Reliability Coordinator did not notify three impacted entities or more than 10% and less than or equal to 15% of the impacted entities whichever is greater, identified in its Operating Plan(s) as to their role in that plan(s).	The Reliability Coordinator did not notify four or more impacted entities or more than 15% of the impacted entities identified in its Operating Plan(s) as to their role in that plan(s).
R4	Same-day Operations, Real-time Operations	High	For any sample 24-hour period within the 30-day retention period, the Reliability	For any sample 24-hour period within the 30-day retention period, the Reliability Coordinator's	For any sample 24-hour period within the 30-day retention period, the Reliability	For any sample 24-hour period within the 30-day retention period, the Reliability Coordinator's Real-time Assessment was not conducted for three or more 30-minute periods

R#	Time Horizons	VRF	Violation Severity Levels			
			Lower VSL	Moderate VSL	High VSL	Severe VSL
			Coordinator’s Real-time Assessment was not conducted for one 30-minute period within that 24-hour period.	Real-time Assessment was not conducted for two 30-minute periods within that 24-hour period.	Coordinator’s Real-time Assessment was not conducted for three 30-minute periods within that 24-hour period.	within that 24-hour period.
R5	Same-Day Operations, Real-time Operations	High	The Reliability Coordinator did not notify, in accordance with its SOL methodology one impacted Transmission Operator or Balancing Authority within its Reliability Coordinator Area or 5% or less of the impacted Transmission Operators and	The Reliability Coordinator did not notify, in accordance with its SOL methodology two impacted Transmission Operators and Balancing Authorities within its Reliability Coordinator Area or more than 5% and less than or equal to 10% of the impacted Transmission	The Reliability Coordinator did not notify, in accordance with its SOL methodology three impacted Transmission Operators and Balancing Authorities within its Reliability Coordinator Area or more than 10% and less than or equal to 15% of	The Reliability Coordinator did not notify, in accordance with its SOL methodology four or more impacted Transmission Operators and Balancing Authorities within its Reliability Coordinator Area or more than 15% of the impacted Transmission Operators and Balancing Authorities within its Reliability Coordinator Area identified in the Operating Plan(s) as to their role in the plan(s).  OR The Reliability Coordinator did not notify the other impacted Reliability Coordinators, as indicated in its Operating Plan,

R#	Time Horizons	VRF	Violation Severity Levels			
			Lower VSL	Moderate VSL	High VSL	Severe VSL
			Balancing Authorities within its Reliability Coordinator Area whichever is greater, when the results of its Real-time Assessment indicate an actual or expected condition that results in, or could result in, a System Operating Limit (SOL) exceedance or an Interconnection Reliability Operating Limit (IROL) exceedance within its Wide	Operators and Balancing Authorities within its Reliability Coordinator Area whichever is greater, when the results of its Real-time Assessment indicate an actual or expected condition that results in, or could result in, a System Operating Limit (SOL) exceedance or an Interconnection Reliability Operating Limit (IROL) exceedance within its Wide Area.	the impacted Transmission Operators and Balancing Authorities within its Reliability Coordinator Area whichever is greater, when the results of its Real-time Assessment indicate an actual or expected condition that results in, or could result in, a System Operating Limit (SOL) exceedance or an Interconnection Reliability Operating Limit (IROL) exceedance within its Wide Area.	when the results of its Real-time Assessment indicate an actual or expected condition that results in, or could result in, a System Operating Limit (SOL) exceedance or an Interconnection Reliability Operating Limit (IROL) exceedance within its Wide Area.

R#	Time Horizons	VRF	Violation Severity Levels			
			Lower VSL	Moderate VSL	High VSL	Severe VSL
			Area.		(IROL) exceedance within its Wide Area.	
R6	Same-Day Operations, Real-time Operations	Medium	The Reliability Coordinator did not notify, in accordance with its SOL methodology one impacted Transmission Operator or Balancing Authority within its Reliability Coordinator Area or 5% or less of the impacted Transmission Operators and Balancing Authorities within its Reliability	The Reliability Coordinator did not notify, in accordance with its SOL methodology two impacted Transmission Operators or Balancing Authorities within its Reliability Coordinator Area or more than 5% and less than or equal to 10% of the impacted Transmission Operators and Balancing Authorities within its Reliability	The Reliability Coordinator did not notify, in accordance with its SOL methodology three impacted Transmission Operators or Balancing Authorities within its Reliability Coordinator Area or more than 10% and less than or equal to 15% of the impacted Transmission Operators and Balancing	The Reliability Coordinator did not notify, in accordance with its SOL methodology four or more impacted Transmission Operators or Balancing Authorities within its Reliability Coordinator Area or more than 15% of the impacted Transmission Operators and Balancing Authorities within its Reliability Coordinator Area when the System Operating Limit (SOL) exceedance or an Interconnection Reliability Operating Limit (IROL) exceedance identified in Requirement R5 was prevented or mitigated.  OR The Reliability Coordinator did not notify four or more other impacted Reliability Coordinators as indicated in its Operating Plan

R#	Time Horizons	VRF	Violation Severity Levels			
			Lower VSL	Moderate VSL	High VSL	Severe VSL
			<p>Coordinator Area whichever is greater, when the System Operating Limit (SOL) exceedance or an Interconnection Reliability Operating Limit (IROL) exceedance identified in Requirement R5 was prevented or mitigated.</p> <p>OR</p> <p>The Reliability Coordinator did not notify one other impacted Reliability Coordinator as indicated in its Operating Plan</p>	<p>Coordinator Area whichever is greater, when the System Operating Limit (SOL) exceedance or an Interconnection Reliability Operating Limit (IROL) exceedance identified in Requirement R6 was prevented or mitigated.</p> <p>OR</p> <p>The Reliability Coordinator did not notify two other impacted Reliability Coordinators as indicated in its Operating Plan when the System Operating Limit</p>	<p>Authorities within its Reliability Coordinator Area whichever is greater, when the System Operating Limit (SOL) exceedance or an Interconnection Reliability Operating Limit (IROL) exceedance identified in Requirement R5 was prevented or mitigated.</p> <p>OR</p> <p>The Reliability Coordinator did not notify three other impacted Reliability</p>	<p>when the System Operating Limit (SOL) exceedance or an Interconnection Reliability Operating Limit (IROL) exceedance identified in Requirement R5 was prevented or mitigated.</p>

R#	Time Horizons	VRF	Violation Severity Levels			
			Lower VSL	Moderate VSL	High VSL	Severe VSL
			when the when the System Operating Limit (SOL) exceedance or an Interconnection Reliability Operating Limit (IROL) exceedance identified in Requirement R5 was prevented or mitigated.	(SOL) exceedance or an Interconnection Reliability Operating Limit (IROL) exceedance identified in Requirement R5 was prevented or mitigated.	Coordinators as indicated in its Operating Plan when the System Operating Limit (SOL) exceedance or an Interconnection Reliability Operating Limit (IROL) exceedance identified in Requirement R5 was prevented or mitigated.	
R7	Same-Day Operations, Real-time Operations	Medium				The Reliability Coordinator failed to use its SOL methodology when determining SOL exceedances for Real-time Assessments, Real-time monitoring, and Operational Planning Analysis.

## D. Regional Variances

None

## E. Interpretations

None

## F. Associated Documents

**Operating Plan** - An Operating Plan includes general Operating Processes and specific Operating Procedures. It may be an overview document which provides a prescription for an Operating Plan for the next-day, or it may be a specific plan to address a specific SOL or IROL exceedance identified in the Operational Planning Analysis (OPA). Consistent with the NERC definition, Operating Plans can be general in nature, or they can be specific plans to address specific reliability issues. The use of the term Operating Plan in the revised TOP/IRO standards allows room for both. An Operating Plan references processes and procedures, including electronic data exchange, which are available to the System Operator on a daily basis to allow the operator to reliably address conditions which may arise throughout the day. It is valid for tomorrow, the day after, and the day after that. Operating Plans should be augmented by temporary operating guides which outline prevention/mitigation plans for specific situations which are identified day-to-day in an OPA or a Real-time Assessment (RTA). As the definition in the Glossary of Terms states, a restoration plan is an example of an Operating Plan. It contains all the overarching principles that the System Operator needs to work his/her way through the restoration process. It is not a specific document written for a specific blackout scenario but rather a collection of tools consisting of processes, procedures, and automated software systems that are available to the operator to use in restoring the system. An Operating Plan can in turn be looked upon in a similar manner. It does not contain a prescription for the specific set-up for tomorrow but contains a treatment of all the processes, procedures, and automated software systems that are at the operator's disposal. The existence of an Operating Plan, however, does not preclude the need for creating specific action plans for specific SOL or IROL exceedances identified in the OPA. When a Reliability Coordinator performs an OPA, the analysis may reveal instances of possible SOL or IROL exceedances for pre- or post-Contingency conditions. In these instances, Reliability Coordinators are expected to ensure that there are plans in place to prevent or mitigate those SOLs or IROLs, should those operating conditions be encountered the next day. The Operating Plan may contain a description of the process by which specific prevention or mitigation plans for day-to-day SOL or IROL exceedances identified in the OPA are handled and communicated. This approach could alleviate any potential administrative burden associated with perceived requirements for continual day-to-day updating of "the Operating Plan document" for compliance purposes.

## Version History

Version	Date	Action	Change Tracking
1	October 17, 2008	Adopted by NERC Board of Trustees	
1	March 17, 2011	Order issued by FERC approving IRO-008-1 (approval effective 5/23/11)	
1	February 28, 2014	Updated VSLs and VRF's based on June 24, 2013 approval.	
2	November 13, 2014	Adopted by NERC Board of Trustees	Revisions under Project 2014-03
2	November 19, 2015	FERC approved IRO-008-2. Docket No. RM15-16-000. Order No. 817	
3	May 13, 2021	Adopted by NERC Board of Trustees	Revisions under Project 2015-09



## A. Introduction

1. **Title:** Reliability Coordinator Operational Analyses and Real-time Assessments
2. **Number:** IRO-008-~~23~~
3. **Purpose:** Perform analyses and assessments to prevent instability, uncontrolled separation, or Cascading.
4. **Applicability**
  - 4.1. Reliability Coordinator.
5. **Proposed Effective Date:**  
See Implementation Plan.
6. **Background**  
See Project 2014-03 [project page](#).

## B. Requirements and Measures

- R1.** Each Reliability Coordinator shall perform an Operational Planning Analysis that will allow it to assess whether the planned operations for the next-day will exceed System Operating Limits (SOLs) and Interconnection Reliability Operating Reliability Limits (IROLs) within its Wide Area. [*Violation Risk Factor: Medium*] [*Time Horizon: Operations Planning*]
- M1.** Each Reliability Coordinator shall have evidence of a completed Operational Planning Analysis. Such evidence could include but is not limited to dated power flow study results.
- R2.** Each Reliability Coordinator shall have a coordinated Operating Plan(s) for next-day operations to address potential System Operating Limit (SOL) and Interconnection Reliability Operating Limit (IROL) exceedances identified as a result of its Operational Planning Analysis as performed in Requirement R1 while considering the Operating Plans for the next-day provided by its Transmission Operators and Balancing Authorities. [*Violation Risk Factor: Medium*] [*Time Horizon: Operations Planning*]
- M2.** Each Reliability Coordinator shall have evidence that it has a coordinated Operating Plan for next-day operations to address potential System Operating Limit (SOL) and Interconnection Reliability Operating Limit (IROL) exceedances identified as a result of the Operational Planning Analysis performed in Requirement R1 while considering the Operating Plans for the next-day provided by its Transmission Operators and Balancing Authorities. Such evidence could include but is not limited to plans for precluding operating in excess of each SOL and IROL that were identified as a result of the Operational Planning Analysis.

- R3.** Each Reliability Coordinator shall notify impacted entities identified in its Operating Plan(s) cited in Requirement R2 as to their role in such plan(s). *[Violation Risk Factor: Medium] [Time Horizon: Operations Planning]*
- M3.** Each Reliability Coordinator shall have evidence that it notified impacted entities identified in its Operating Plan(s) cited in Requirement R2 as to their role in such plan(s). Such evidence could include, but is not limited to, dated operator logs, or e-mail records.
- R4.** Each Reliability Coordinator shall ensure that a Real-time Assessment is performed at least once every 30 minutes. *[Violation Risk Factor: High] [Time Horizon: Same-day Operations, Real-time Operations]*
- M4.** Each Reliability Coordinator shall have, and make available upon request, evidence to show it ensured that a Real-time Assessment is performed at least once every 30 minutes. This evidence could include but is not limited to dated computer logs showing times the assessment was conducted, dated checklists, or other evidence.
- R5.** Each Reliability Coordinator shall notify, in accordance with its SOL methodology, impacted Transmission Operators and Balancing Authorities within its Reliability Coordinator Area, and other impacted Reliability Coordinators as indicated in its Operating Plan, when the results of a Real-time Assessment indicate an actual or expected condition that results in, or could result in, a System Operating Limit (SOL) exceedance or an Interconnection Reliability Operating Limit (IROL) exceedance within its Wide Area. *[Violation Risk Factor: High] [Time Horizon: Same-Day Operations, Real-time Operations]*
- M5.** Each Reliability Coordinator shall make available upon request, evidence that it informed, in accordance with its SOL methodology impacted Transmission Operators and Balancing Authorities within its Reliability Coordinator Area, and other impacted Reliability Coordinators as indicated in its Operating Plan, of its actual or expected operations that result in, or could result in, a System Operating Limit (SOL) exceedance or an Interconnection Reliability Operating Limit (IROL) exceedance within its Wide Area. Such evidence could include but is not limited to dated operator logs, voice recordings or transcripts of voice recordings, electronic communications, or other equivalent evidence. If such a situation has not occurred, the Reliability Coordinator may provide an attestation.
- R6.** Each Reliability Coordinator shall notify, in accordance with SOL methodology, impacted Transmission Operators and Balancing Authorities within its Reliability Coordinator Area, and other impacted Reliability Coordinators as indicated in its Operating Plan, when the System Operating Limit (SOL) exceedance or an Interconnection Reliability Operating Limit (IROL) exceedance identified in Requirement R5 has been prevented or mitigated. *[Violation Risk Factor: Medium] [Time Horizon: Same-Day Operations, Real-time Operations]*

- M6.** Each Reliability Coordinator shall make available upon request, evidence that it informed, in accordance with its SOL methodology impacted Transmission Operators and Balancing Authorities within its Reliability Coordinator Area, and other impacted Reliability Coordinators as indicated in its Operating Plan, when the System Operating Limit (SOL) exceedance or an Interconnection Reliability Operating Limit (IROL) exceedance identified in Requirement R5 has been prevented or mitigated. Such evidence could include but is not limited to dated operator logs, voice recordings or transcripts of voice recordings, electronic communications, or other equivalent evidence. If such a situation has not occurred, the Reliability Coordinator may provide an attestation.
- R7.** Each Reliability Coordinator shall use its SOL methodology when determining SOL exceedances for Real-time Assessments, Real-time monitoring, and Operational Planning Analysis. [Violation Risk Factor: Medium ] [Time Horizon: Same-Day Operations, Real-time Operations, Operations Planning]
- M7.** Each Reliability Coordinator shall have, and provide upon request, evidence that it used its SOL methodology for determining SOL exceedances for Real-time Assessments, Real-time monitoring, and Operational Planning Analysis. Evidence could include, but is not limited to: Operating Plans, contingency sets, SOLs, alarming and study reporting thresholds, operator logs, voice recordings or other equivalent evidence.

## C. Compliance

### 1. Compliance Monitoring Process

#### 1.1. Compliance Enforcement Authority

As defined in the NERC Rules of Procedure, “Compliance Enforcement Authority” (CEA) means NERC or the Regional Entity in their respective roles of monitoring and enforcing compliance with the NERC Reliability Standards.

#### 1.2. Compliance Monitoring and Assessment Processes

As defined in the NERC Rules of Procedure, “Compliance Monitoring and Assessment Processes” refers to the identification of the processes that will be used to evaluate data or information for the purpose of assessing performance or outcomes with the associated reliability standard.

#### 1.3. Data Retention

The following evidence retention periods identify the period of time an entity is required to retain specific evidence to demonstrate compliance. For instances where the evidence retention period specified below is shorter than the time since the last audit, the Compliance Enforcement Authority may ask an entity to provide other evidence to show that it was compliant for the full time period since the last audit.

Each Reliability Coordinator shall keep data or evidence to show compliance for Requirements R1 through R3, R5, ~~and R6, and R7~~ and Measures M1 through M3, M5, ~~and M6, and M7~~ for a rolling 90-calendar days period for analyses, the most recent 90-calendar days for voice recordings, and 12 months for operating logs and e-mail records unless directed by its Compliance Enforcement Authority to retain specific evidence for a longer period of time as part of an investigation.

Each Reliability Coordinator shall each keep data or evidence for Requirement R4 and Measure M4 for a rolling 30-calendar day period, unless directed by its Compliance Enforcement Authority to retain specific evidence for a longer period of time as part of an investigation.

If a Reliability Coordinator is found non-compliant, it shall keep information related to the non-compliance until found compliant or the time period specified above, whichever is longer.

The Compliance Enforcement Authority shall keep the last audit records and all requested and submitted subsequent audit records.

#### 1.4. Additional Compliance Information

None

**Table of Compliance Elements**

R#	Time Horizons	VRF	Violation Severity Levels			
			Lower VSL	Moderate VSL	High VSL	Severe VSL
R1	Operations Planning	Medium	N/A	N/A	N/A	The Reliability Coordinator did not perform an Operational Planning Analysis allowing it to assess whether its planned operations for the next-day within its Wide Area will exceed any of its System Operating Limits (SOLs) and Interconnection <del>Reliability</del> Operating <del>Reliability</del> Limits (IROLs).
R2	Operations Planning	Medium	N/A	N/A	N/A	The Reliability Coordinator did not have a coordinated Operating Plan(s) for next-day operations to address potential System Operating Limit (SOL) and Interconnection Reliability Operating Limit (IROL) exceedances identified as a result of its Operational Planning Analysis as performed in Requirement R1 while considering the Operating Plans for the next-day provided by its Transmission Operators and Balancing

R#	Time Horizons	VRF	Violation Severity Levels			
			Lower VSL	Moderate VSL	High VSL	Severe VSL
						Authorities.
<p>For the Requirement R3 and R5 VSLs, the intent of the SDT is to start with the Severe VSL first and then to work your way to the left until you find the situation that fits. In this manner, the VSL will not be discriminatory by size. If a Reliability Coordinator has just one affected reliability entity to inform, the intent is that that situation would be a Severe violation</p>						
R3	Operations Planning	Medium	The Reliability Coordinator did not notify one impacted entity or 5% or less of the impacted entities whichever is greater identified in its Operating Plan(s) as to their role in that plan(s).	The Reliability Coordinator did not notify two impacted entities or more than 5% and less than or equal to 10% of the impacted entities whichever is greater, identified in its Operating Plan(s) as to their role in that plan(s).	The Reliability Coordinator did not notify three impacted entities or more than 10% and less than or equal to 15% of the impacted entities whichever is greater, identified in its Operating Plan(s) as to their role in that plan(s).	The Reliability Coordinator did not notify four or more impacted entities or more than 15% of the impacted entities identified in its Operating Plan(s) as to their role in that plan(s).
R4	Same-day Operations, Real-time	High	For any sample 24-hour period within the 30-day retention	For any sample 24-hour period within the 30-day retention period,	For any sample 24-hour period within the 30-day retention	For any sample 24-hour period within the 30-day retention period, the Reliability Coordinator’s Real-time

R#	Time Horizons	VRF	Violation Severity Levels			
			Lower VSL	Moderate VSL	High VSL	Severe VSL
	Operations		period, the Reliability Coordinator’s Real-time Assessment was not conducted for one 30-minute period within that 24-hour period.	the Reliability Coordinator’s Real-time Assessment was not conducted for two 30-minute periods within that 24-hour period.	period, the Reliability Coordinator’s Real-time Assessment was not conducted for three 30-minute periods within that 24-hour period.	Assessment was not conducted for three or more 30-minute periods within that 24-hour period.
R5	Same-Day Operations, Real-time Operations	High	The Reliability Coordinator did not notify, <u>in accordance with its SOL methodology</u> one impacted Transmission Operator or Balancing Authority within its Reliability Coordinator Area or 5% or less of the impacted	The Reliability Coordinator did not notify, <u>in accordance with its SOL methodology</u> two impacted Transmission Operators and Balancing Authorities within its Reliability Coordinator Area or more than 5% and less than or equal to 10% of	The Reliability Coordinator did not notify, <u>in accordance with its SOL methodology</u> three impacted Transmission Operators and Balancing Authorities within its Reliability Coordinator Area or more than 10% and	The Reliability Coordinator did not <del>notify</del> , <u>notify, in accordance with its SOL methodology</u> four or more impacted Transmission Operators and Balancing Authorities within its Reliability Coordinator Area or more than 15% of the impacted Transmission Operators and Balancing Authorities within its Reliability Coordinator Area identified in the Operating Plan(s) as to their role in the plan(s).  OR The Reliability Coordinator did not notify the other impacted

R#	Time Horizons	VRF	Violation Severity Levels			
			Lower VSL	Moderate VSL	High VSL	Severe VSL
			Transmission Operators and Balancing Authorities within its Reliability Coordinator Area whichever is greater, when the results of its Real-time Assessment indicate an actual or expected condition that results in, or could result in, a System Operating Limit (SOL) <u>exceedance</u> or <u>an</u> Interconnection Reliability Operating Limit (IROL)	the impacted Transmission Operators and Balancing Authorities within its Reliability Coordinator Area whichever is greater, when the results of its Real-time Assessment indicate an actual or expected condition that results in, or could result in, a System Operating Limit (SOL) <u>exceedance</u> or <u>an</u> Interconnection Reliability Operating Limit (IROL) exceedance within its Wide Area.	less than or equal to 15% of the impacted Transmission Operators and Balancing Authorities within its Reliability Coordinator Area whichever is greater, when the results of its Real-time Assessment indicate an actual or expected condition that results in, or could result in, a System Operating Limit (SOL) <u>exceedance</u> or <u>an</u> Interconnection	Reliability Coordinators, as indicated in its Operating Plan, when the results of its Real-time Assessment indicate an actual or expected condition that results in, or could result in, a System Operating Limit (SOL) <u>exceedance</u> or <u>an</u> Interconnection Reliability Operating Limit (IROL) exceedance within its Wide Area.



R#	Time Horizons	VRF	Violation Severity Levels			
			Lower VSL	Moderate VSL	High VSL	Severe VSL
			exceedance within its Wide Area.		Reliability Operating Limit (IROL) exceedance within its Wide Area.	
R6	Same-Day Operations, Real-time Operations	Medium	The Reliability Coordinator did not notify, <u>in accordance with its SOL methodology</u> one impacted Transmission Operator or Balancing Authority within its Reliability Coordinator Area or 5% or less of the impacted Transmission Operators and Balancing Authorities	The Reliability Coordinator did not notify, <u>in accordance with its SOL methodology</u> two impacted Transmission Operators or Balancing Authorities within its Reliability Coordinator Area or more than 5% and less than or equal to 10% of the impacted Transmission Operators and Balancing	The Reliability Coordinator did not notify, <u>in accordance with its SOL methodology</u> three impacted Transmission Operators or Balancing Authorities within its Reliability Coordinator Area or more than 10% and less than or equal to 15% of the impacted Transmission	The Reliability Coordinator did not <del>notify</del> , <u>notify, in accordance with its SOL methodology</u> four or more impacted Transmission Operators or Balancing Authorities within its Reliability Coordinator Area or more than 15% of the impacted Transmission Operators and Balancing Authorities within its Reliability Coordinator Area when the System Operating Limit (SOL) <u>exceedance</u> or <u>an</u> Interconnection Reliability Operating Limit (IROL) exceedance identified in Requirement R5 was prevented or mitigated.  OR The Reliability Coordinator did not notify four or more other

R#	Time Horizons	VRF	Violation Severity Levels			
			Lower VSL	Moderate VSL	High VSL	Severe VSL
			within its Reliability Coordinator Area whichever is greater, when the System Operating Limit (SOL) <u>exceedance</u> or <u>an</u> Interconnection Reliability Operating Limit (IROL) exceedance identified in Requirement R5 was prevented or mitigated.  OR  The Reliability Coordinator did not notify one other impacted Reliability Coordinator as	Authorities within its Reliability Coordinator Area whichever is greater, when the System Operating Limit (SOL) <u>exceedance</u> or <u>an</u> Interconnection Reliability Operating Limit (IROL) exceedance identified in Requirement R6 was prevented or mitigated.  OR  The Reliability Coordinator did not notify two other impacted Reliability Coordinators as indicated in its Operating Plan	Operators and Balancing Authorities within its Reliability Coordinator Area whichever is greater, when the System Operating Limit (SOL) <u>exceedance</u> or <u>an</u> Interconnection Reliability Operating Limit (IROL) exceedance identified in Requirement R5 was prevented or mitigated.  OR  The Reliability Coordinator did not notify three	impacted Reliability Coordinators as indicated in its Operating Plan when the System Operating Limit (SOL) <u>exceedance</u> or <u>an</u> Interconnection Reliability Operating Limit (IROL) exceedance identified in Requirement R5 was prevented or mitigated.

R#	Time Horizons	VRF	Violation Severity Levels			
			Lower VSL	Moderate VSL	High VSL	Severe VSL
			indicated in its Operating Plan when the when the System Operating Limit (SOL) <u>exceedance</u> or <u>an</u> Interconnection Reliability Operating Limit (IROL) exceedance identified in Requirement R5 was prevented or mitigated.	when the System Operating Limit (SOL) <u>exceedance</u> or <u>an</u> Interconnection Reliability Operating Limit (IROL) exceedance identified in Requirement R5 was prevented or mitigated.	other impacted Reliability Coordinators as indicated in its Operating Plan when the System Operating Limit (SOL) <u>exceedance</u> or <u>an</u> Interconnection Reliability Operating Limit (IROL) exceedance identified in Requirement R5 was prevented or mitigated.	
<u>R7</u>	<u>Same-Day Operations,</u> <u>Real-time Operations</u>	<u>Medium</u>				<u>The Reliability Coordinator failed to use its SOL methodology when determining SOL exceedances for Real-time Assessments, Real-time Monitoring, and Operational Planning Analysis.</u>



## D. Regional Variances

None

## E. Interpretations

None

## F. Associated Documents

**Operating Plan** - An Operating Plan includes general Operating Processes and specific Operating Procedures. It may be an overview document which provides a prescription for an Operating Plan for the next-day, or it may be a specific plan to address a specific SOL or IROL exceedance identified in the Operational Planning Analysis (OPA). Consistent with the NERC definition, Operating Plans can be general in nature, or they can be specific plans to address specific reliability issues. The use of the term Operating Plan in the revised TOP/IRO standards allows room for both. An Operating Plan references processes and procedures, including electronic data exchange, which are available to the System Operator on a daily basis to allow the operator to reliably address conditions which may arise throughout the day. It is valid for tomorrow, the day after, and the day after that. Operating Plans should be augmented by temporary operating guides which outline prevention/mitigation plans for specific situations which are identified day-to-day in an OPA or a Real-time Assessment (RTA). As the definition in the Glossary of Terms states, a restoration plan is an example of an Operating Plan. It contains all the overarching principles that the System Operator needs to work his/her way through the restoration process. It is not a specific document written for a specific blackout scenario but rather a collection of tools consisting of processes, procedures, and automated software systems that are available to the operator to use in restoring the system. An Operating Plan can in turn be looked upon in a similar manner. It does not contain a prescription for the specific set-up for tomorrow but contains a treatment of all the processes, procedures, and automated software systems that are at the operator's disposal. The existence of an Operating Plan, however, does not preclude the need for creating specific action plans for specific SOL or IROL exceedances identified in the OPA. When a Reliability Coordinator performs an OPA, the analysis may reveal instances of possible SOL or IROL exceedances for pre- or post-Contingency conditions. In these instances, Reliability Coordinators are expected to ensure that there are plans in place to prevent or mitigate those SOLs or IROLs, should those operating conditions be encountered the next day. The Operating Plan may contain a description of the process by which specific prevention or mitigation plans for day-to-day SOL or IROL exceedances identified in the OPA are handled and communicated. This approach could alleviate any potential administrative burden associated with perceived requirements for continual day-to-day updating of "the Operating Plan document" for compliance purposes.

## Version History

Version	Date	Action	Change Tracking
1	October 17, 2008	Adopted by NERC Board of Trustees	
1	March 17, 2011	Order issued by FERC approving IRO-008-1 (approval effective 5/23/11)	
1	February 28, 2014	Updated VSLs and VRF's based on June 24, 2013 approval.	
2	November 13, 2014	Adopted by NERC Board of Trustees	Revisions under Project 2014-03
2	November 19, 2015	FERC approved IRO-008-2. Docket No. RM15-16-000. Order No. 817	
3	May 13, 2021	Adopted by NERC Board of Trustees	Revisions under Project 2015-09

Exhibit A-6

PRC-002-3 (Clean and Redline to Last Approved)

## A. Introduction

1. **Title:** Disturbance Monitoring and Reporting Requirements
2. **Number:** PRC-002-3
3. **Purpose:** To have adequate data available to facilitate analysis of Bulk Electric System (BES) Disturbances.
4. **Applicability:**
  - Functional Entities:**
    - 4.1 Reliability Coordinator
    - 4.2 Transmission Owner
    - 4.3 Generator Owner
5. **Effective Date:** See Implementation Plan

## B. Requirements and Measures

- R1.** Each Transmission Owner shall: *[Violation Risk Factor: Lower ] [Time Horizon: Long-term Planning]*
  - 1.1. Identify BES buses for which sequence of events recording (SER) and fault recording (FR) data is required by using the methodology in PRC-002-3, Attachment 1.
  - 1.2. Notify other owners of BES Elements connected to those BES buses, if any, within 90-calendar days of completion of Part 1.1, that those BES Elements require SER data and/or FR data.
  - 1.3. Re-evaluate all BES buses at least once every five calendar years in accordance with Part 1.1 and notify other owners, if any, in accordance with Part 1.2, and implement the re-evaluated list of BES buses as per the Implementation Plan.
- M1.** The Transmission Owner has a dated (electronic or hard copy) list of BES buses for which SER and FR data is required, identified in accordance with PRC-002-3, Attachment 1, and evidence that all BES buses have been re-evaluated within the required intervals under Requirement R1. The Transmission Owner will also have dated (electronic or hard copy) evidence that it notified other owners in accordance with Requirement R1.
- R2.** Each Transmission Owner and Generator Owner shall have SER data for circuit breaker position (open/close) for each circuit breaker it owns connected directly to the BES buses identified in Requirement R1 and associated with the BES Elements at those BES buses. *[Violation Risk Factor: Lower ] [Time Horizon: Long-term Planning]*
- M2.** The Transmission Owner or Generator Owner has evidence (electronic or hard copy) of SER data for circuit breaker position as specified in Requirement R2. Evidence may



include, but is not limited to: (1) documents describing the device interconnections and configurations which may include a single design standard as representative for common installations; or (2) actual data recordings; or (3) station drawings.

- R3.** Each Transmission Owner and Generator Owner shall have FR data to determine the following electrical quantities for each triggered FR for the BES Elements it owns connected to the BES buses identified in Requirement R1: *[Violation Risk Factor: Lower] [Time Horizon: Long-term Planning]*

**3.1** Phase-to-neutral voltage for each phase of each specified BES bus.

**3.2** Each phase current and the residual or neutral current for the following BES Elements:

**3.2.1** Transformers that have a low-side operating voltage of 100kV or above.

**3.2.2** Transmission Lines.

- M3.** The Transmission Owner or Generator Owner has evidence (electronic or hard copy) of FR data that is sufficient to determine electrical quantities as specified in Requirement R3. Evidence may include, but is not limited to: (1) documents describing the device specifications and configurations which may include a single design standard as representative for common installations; or (2) actual data recordings or derivations; or (3) station drawings.

- R4.** Each Transmission Owner and Generator Owner shall have FR data as specified in Requirement R3 that meets the following: *[Violation Risk Factor: Lower] [Time Horizon: Long-term Planning]*

**4.1** A single record or multiple records that include:

- A pre-trigger record length of at least two cycles and a total record length of at least 30-cycles for the same trigger point, or
- At least two cycles of the pre-trigger data, the first three cycles of the post-trigger data, and the final cycle of the fault as seen by the fault recorder.

**4.2** A minimum recording rate of 16 samples per cycle.

**4.3** Trigger settings for at least the following:

**4.3.1** Neutral (residual) overcurrent.

**4.3.2** Phase undervoltage or overcurrent.

- M4.** The Transmission Owner or Generator Owner has evidence (electronic or hard copy) that FR data meets Requirement R4. Evidence may include, but is not limited to: (1) documents describing the device specification (R4, Part 4.2) and device configuration or settings (R4, Parts 4.1 and 4.3), or (2) actual data recordings or derivations.

- R5.** Each Reliability Coordinator shall: *[Violation Risk Factor: Lower] [Time Horizon: Long-term Planning]*

- 5.1** Identify BES Elements for which dynamic Disturbance recording (DDR) data is required, including the following:
    - 5.1.1** Generating resource(s) with:
      - 5.1.1.1** Gross individual nameplate rating greater than or equal to 500 MVA.
      - 5.1.1.2** Gross individual nameplate rating greater than or equal to 300 MVA where the gross plant/facility aggregate nameplate rating is greater than or equal to 1,000 MVA.
    - 5.1.2** Any one BES Element that is part of a stability (angular or voltage) related System Operating Limit (SOL).
    - 5.1.3** Each terminal of a high voltage direct current (HVDC) circuit with a nameplate rating greater than or equal to 300 MVA, on the alternating current (AC) portion of the converter.
    - 5.1.4** One or more BES Elements that are part of an Interconnection Reliability Operating Limit (IROL).
    - 5.1.5** Any one BES Element within a major voltage sensitive area as defined by an area with an in-service undervoltage load shedding (UVLS) program.
  - 5.2** Identify a minimum DDR coverage, inclusive of those BES Elements identified in Part 5.1, of at least:
    - 5.2.1** One BES Element; and
    - 5.2.2** One BES Element per 3,000 MW of the Reliability Coordinator's historical simultaneous peak System Demand.
  - 5.3** Notify all owners of identified BES Elements, within 90-calendar days of completion of Part 5.1, that their respective BES Elements require DDR data when requested.
  - 5.4** Re-evaluate all BES Elements at least once every five calendar years in accordance with Parts 5.1 and 5.2, and notify owners in accordance with Part 5.3 to implement the re-evaluated list of BES Elements as per the Implementation Plan.
- M5.** The Reliability Coordinator has a dated (electronic or hard copy) list of BES Elements for which DDR data is required, developed in accordance with Requirement R5, Part 5.1 and Part 5.2; and re-evaluated in accordance with Part 5.4. The Reliability Coordinator has dated evidence (electronic or hard copy) that each Transmission Owner or Generator Owner has been notified in accordance with Requirement 5, Part 5.3. Evidence may include, but is not limited to: letters, emails, electronic files, or hard copy records demonstrating transmittal of information.
- R6.** Each Transmission Owner shall have DDR data to determine the following electrical quantities for each BES Element it owns for which it received notification as identified in Requirement R5: *[Violation Risk Factor: Lower] [Time Horizon: Long-term Planning ]*

- 6.1 One phase-to-neutral or positive sequence voltage.
  - 6.2 The phase current for the same phase at the same voltage corresponding to the voltage in Requirement R6, Part 6.1, or the positive sequence current.
  - 6.3 Real Power and Reactive Power flows expressed on a three phase basis corresponding to all circuits where current measurements are required.
  - 6.4 Frequency of any one of the voltage(s) in Requirement R6, Part 6.1.
- M6.** The Transmission Owner has evidence (electronic or hard copy) of DDR data to determine electrical quantities as specified in Requirement R6. Evidence may include, but is not limited to: (1) documents describing the device specifications and configurations, which may include a single design standard as representative for common installations; or (2) actual data recordings or derivations; or (3) station drawings.
- R7.** Each Generator Owner shall have DDR data to determine the following electrical quantities for each BES Element it owns for which it received notification as identified in Requirement R5: *[Violation Risk Factor: Lower] [Time Horizon: Long-term Planning]*
- 7.1 One phase-to-neutral, phase-to-phase, or positive sequence voltage at either the generator step-up transformer (GSU) high-side or low-side voltage level.
  - 7.2 The phase current for the same phase at the same voltage corresponding to the voltage in Requirement R7, Part 7.1, phase current(s) for any phase-to-phase voltages, or positive sequence current.
  - 7.3 Real Power and Reactive Power flows expressed on a three phase basis corresponding to all circuits where current measurements are required.
  - 7.4 Frequency of at least one of the voltages in Requirement R7, Part 7.1.
- M7.** The Generator Owner has evidence (electronic or hard copy) of DDR data to determine electrical quantities as specified in Requirement R7. Evidence may include, but is not limited to: (1) documents describing the device specifications and configurations, which may include a single design standard as representative for common installations; or (2) actual data recordings or derivations; or (3) station drawings.
- R8.** Each Transmission Owner and Generator Owner responsible for DDR data for the BES Elements identified in Requirement R5 shall have continuous data recording and storage. If the equipment was installed prior to the effective date of this standard and is not capable of continuous recording, triggered records must meet the following: *[Violation Risk Factor: Lower] [Time Horizon: Long-term Planning]*
- 8.1 Triggered record lengths of at least three minutes.
  - 8.2 At least one of the following three triggers:
    - Off nominal frequency trigger set at:

	Low	High
○ Eastern Interconnection	<59.75 Hz	>61.0 Hz
○ Western Interconnection	<59.55 Hz	>61.0 Hz
○ ERCOT Interconnection	<59.35 Hz	>61.0 Hz
○ Hydro-Quebec Interconnection	<58.55 Hz	>61.5 Hz
● Rate of change of frequency trigger set at:		
○ Eastern Interconnection	< -0.03125 Hz/sec	> 0.125 Hz/sec
○ Western Interconnection	< -0.05625 Hz/sec	> 0.125 Hz/sec
○ ERCOT Interconnection	< -0.08125 Hz/sec	> 0.125 Hz/sec
○ Hydro-Quebec Interconnection	< -0.18125 Hz/sec	> 0.1875 Hz/sec

- Undervoltage trigger set no lower than 85 percent of normal operating voltage for a duration of 5 seconds.

**M8.** Each Transmission Owner and Generator Owner has dated evidence (electronic or hard copy) of data recordings and storage in accordance with Requirement R8. Evidence may include, but is not limited to: (1) documents describing the device specifications and configurations, which may include a single design standard as representative for common installations; or (2) actual data recordings.

**R9.** Each Transmission Owner and Generator Owner responsible for DDR data for the BES Elements identified in Requirement R5 shall have DDR data that meet the following: *[Violation Risk Factor: Lower] [Time Horizon: Long-term Planning]*

**9.1** Input sampling rate of at least 960 samples per second.

**9.2** Output recording rate of electrical quantities of at least 30 times per second.

**M9.** The Transmission Owner or Generator Owner has evidence (electronic or hard copy) that DDR data meets Requirement R9. Evidence may include, but is not limited to: (1) documents describing the device specification, device configuration, or settings (R9, Part 9.1; R9, Part 9.2); or (2) actual data recordings (R9, Part 9.2).

**R10.** Each Transmission Owner and Generator Owner shall time synchronize all SER and FR data for the BES buses identified in Requirement R1 and DDR data for the BES Elements identified in Requirement R5 to meet the following: *[Violation Risk Factor: Lower] [Time Horizon: Long-term Planning]*

**10.1** Synchronization to Coordinated Universal Time (UTC) with or without a local time offset.

**10.2** Synchronized device clock accuracy within  $\pm 2$  milliseconds of UTC.

- M10.** The Transmission Owner or Generator Owner has evidence (electronic or hard copy) of time synchronization described in Requirement R10. Evidence may include, but is not limited to: (1) documents describing the device specification, configuration, or setting; (2) time synchronization indication or status; or (3) station drawings.
- R11.** Each Transmission Owner and Generator Owner shall provide, upon request, all SER and FR data for the BES buses identified in Requirement R1 and DDR data for the BES Elements identified in Requirement R5 to the Reliability Coordinator, Regional Entity, or NERC in accordance with the following: *[Violation Risk Factor: Lower] [Time Horizon: Long-term Planning]*
- 11.1** Data will be retrievable for the period of 10-calendar days, inclusive of the day the data was recorded.
- 11.2** Data subject to Part 11.1 will be provided within 30-calendar days of a request unless an extension is granted by the requestor.
- 11.3** SER data will be provided in ASCII Comma Separated Value (CSV) format following Attachment 2.
- 11.4** FR and DDR data will be provided in electronic files that are formatted in conformance with C37.111, (IEEE Standard for Common Format for Transient Data Exchange (COMTRADE), revision C37.111-1999 or later.
- 11.5** Data files will be named in conformance with C37.232, IEEE Standard for Common Format for Naming Time Sequence Data Files (COMNAME), revision C37.232-2011 or later.
- M11.** The Transmission Owner or Generator Owner has evidence (electronic or hard copy) that data was submitted upon request in accordance with Requirement R11. Evidence may include, but is not limited to: (1) dated transmittals to the requesting entity with formatted records; (2) documents describing data storage capability, device specification, configuration or settings; or (3) actual data recordings.
- R12.** Each Transmission Owner and Generator Owner shall, within 90-calendar days of the discovery of a failure of the recording capability for the SER, FR or DDR data, either: *[Violation Risk Factor: Lower] [Time Horizon: Long-term Planning]*
- Restore the recording capability, or
  - Submit a Corrective Action Plan (CAP) to the Regional Entity and implement it.
- M12.** The Transmission Owner or Generator Owner has dated evidence (electronic or hard copy) that meets Requirement R12. Evidence may include, but is not limited to: (1) dated reports of discovery of a failure, (2) documentation noting the date the data recording was restored, (3) SCADA records, or (4) dated CAP transmittals to the Regional Entity and evidence that it implemented the CAP.

## C. Compliance

### 1. Compliance Monitoring Process

#### 1.1. Compliance Enforcement Authority

As defined in the NERC Rules of Procedure, “Compliance Enforcement Authority” (CEA) means NERC or the Regional Entity in their respective roles of monitoring and enforcing compliance with the NERC Reliability Standards.

#### 1.2. Evidence Retention

The following evidence retention periods identify the period of time an entity is required to retain specific evidence to demonstrate compliance. For instances where the evidence retention period specified below is shorter than the time since the last audit, the Compliance Enforcement Authority may ask an entity to provide other evidence to show that it was compliant for the full time period since the last audit.

The Transmission Owner, Generator Owner, and Reliability Coordinator shall keep data or evidence to show compliance as identified below unless directed by its Compliance Enforcement Authority to retain specific evidence for a longer period of time as part of an investigation:

The Transmission Owner shall retain evidence of Requirement R1, Measure M1 for five calendar years.

The Transmission Owner shall retain evidence of Requirement R6, Measure M6 for three calendar years.

The Generator Owner shall retain evidence of Requirement R7, Measure M7 for three calendar years.

The Transmission Owner and Generator Owner shall retain evidence of requested data provided as per Requirements R2, R3, R4, R8, R9, R10, R11, and R12, Measures M2, M3, M4, M8, M9, M10, M11, and M12 for three calendar years.

The Reliability Coordinator shall retain evidence of Requirement R5, Measure M5 for five calendar years.

If a Transmission Owner, Generator Owner, or Reliability Coordinator is found non-compliant, it shall keep information related to the non-compliance until mitigation is completed and approved or for the time specified above, whichever is longer.

The Compliance Enforcement Authority shall keep the last audit records and all requested and submitted subsequent audit records.

#### 1.3. Compliance Monitoring and Assessment Processes:

Compliance Audit

Self-Certification

Spot Checking

Compliance Violation Investigation

Self-Reporting

Complaints

**1.4. Additional Compliance Information**

None

**Table of Compliance Elements**

R #	Time Horizon	VRF	Violation Severity Levels			
			Lower VSL	Moderate VSL	High VSL	Severe VSL
R1	Long-term Planning	Lower	<p>The Transmission Owner identified the BES buses as directed by Requirement R1, Part 1.1 or Part 1.3 for more than 80 percent but less than 100 percent of the required BES buses that they own.</p> <p>OR</p> <p>The Transmission Owner evaluated the BES buses as directed by Requirement R1, Part 1.1 or Part 1.3 but was late by 30-calendar days or less.</p> <p>OR</p> <p>The Transmission Owner as directed by Requirement R1, Part 1.2 was late in notifying the other</p>	<p>The Transmission Owner identified the BES buses as directed by Requirement R1, Part 1.1 or Part 1.3 for more than 70 percent but less than or equal to 80 percent of the required BES buses that they own.</p> <p>OR</p> <p>The Transmission Owner evaluated the BES buses as directed by Requirement R1, Part 1.1 or Part 1.3 but was late by greater than 30-calendar days and less than or equal to 60-calendar days.</p> <p>OR</p> <p>The Transmission Owner as directed by Requirement R1, Part</p>	<p>The Transmission Owner identified the BES buses as directed by Requirement R1, Part 1.1 or Part 1.3 for more than 60 percent but less than or equal to 70 percent of the required BES buses that they own.</p> <p>OR</p> <p>The Transmission Owner evaluated the BES buses as directed by Requirement R1, Part 1.1 or Part 1.3 but was late by greater than 60-calendar days and less than or equal to 90-calendar days.</p> <p>OR</p> <p>The Transmission Owner as directed by Requirement R1, Part</p>	<p>The Transmission Owner identified the BES buses as directed by Requirement R1, Part 1.1 or Part 1.3 for less than or equal to 60 percent of the required BES buses that they own.</p> <p>OR</p> <p>The Transmission Owner evaluated the BES buses as directed by Requirement R1, Part 1.1 or Part 1.3 but was late by greater than 90-calendar days.</p> <p>OR</p> <p>The Transmission Owner as directed by Requirement R1, Part 1.2 was late in notifying one or more other owners by</p>



**PRC-002-3 — Disturbance Monitoring and Reporting Requirements**

			owners by 10-calendar days or less.	1.2 was late in notifying the other owners by greater than 10-calendar days but less than or equal to 20-calendar days.	1.2 was late in notifying the other owners by greater than 20-calendar days but less than or equal to 30-calendar days.	greater than 30-calendar days.
<b>R2</b>	Long-term Planning	Lower	Each Transmission Owner or Generator Owner as directed by Requirement R2 had more than 80 percent but less than 100 percent of the total SER data for circuit breaker position (open/close) for each of the circuit breakers at the BES buses identified in Requirement R1.	Each Transmission Owner or Generator Owner as directed by Requirement R2 had more than 70 percent but less than or equal to 80 percent of the total SER data for circuit breaker position (open/close) for each of the circuit breakers at the BES buses identified in Requirement R1.	Each Transmission Owner or Generator Owner as directed by Requirement R2 had more than 60 percent but less than or equal to 70 percent of the total SER data for circuit breaker position (open/close) for each of the circuit breakers at the BES buses identified in Requirement R1.	Each Transmission Owner or Generator Owner as directed by Requirement R2 for less than or equal to 60 percent of the total SER data for circuit breaker position (open/close) for each of the circuit breakers at the BES buses identified in Requirement R1.
<b>R3</b>	Long-term Planning	Lower	The Transmission Owner or Generator Owner had FR data as directed by Requirement R3, Parts 3.1 and 3.2 that covers more than 80 percent but less than 100 percent of the total set of required electrical	The Transmission Owner or Generator Owner had FR data as directed by Requirement R3, Parts 3.1 and 3.2 that covers more than 70 percent but less than or equal to 80 percent of the total set of required	The Transmission Owner or Generator Owner had FR data as directed by Requirement R3, Parts 3.1 and 3.2 that covers more than 60 percent but less than or equal to 70 percent of the total set of required	The Transmission Owner or Generator Owner had FR data as directed by Requirement R3, Parts 3.1 and 3.2 that covers less than or equal to 60 percent of the total set of required electrical quantities,

			quantities, which is the product of the total number of monitored BES Elements and the number of specified electrical quantities for each BES Element.	electrical quantities, which is the product of the total number of monitored BES Elements and the number of specified electrical quantities for each BES Element.	electrical quantities, which is the product of the total number of monitored BES Elements and the number of specified electrical quantities for each BES Element.	which is the product of the total number of monitored BES Elements and the number of specified electrical quantities for each BES Element.
<b>R4</b>	Long-term Planning	Lower	The Transmission Owner or Generator Owner had FR data that meets more than 80 percent but less than 100 percent of the total recording properties as specified in Requirement R4.	The Transmission Owner or Generator Owner had FR data that meets more than 70 percent but less than or equal to 80 percent of the total recording properties as specified in Requirement R4.	The Transmission Owner or Generator Owner had FR data that meets more than 60 percent but less than or equal to 70 percent of the total recording properties as specified in Requirement R4.	The Transmission Owner or Generator Owner had FR data that meets less than or equal to 60 percent of the total recording properties as specified in Requirement R4.
<b>R5</b>	Long-term Planning	Lower	The Reliability Coordinator identified the BES Elements for which DDR data is required as directed by Requirement R5 for more than 80 percent but less than 100 percent of the required BES Elements included in Part 5.1.	The Reliability Coordinator identified the BES Elements for which DDR data is required as directed by Requirement R5 for more than 70 percent but less than or equal to 80 percent of the required BES Elements included in Part 5.1.	The Reliability Coordinator identified the BES Elements for which DDR data is required as directed by Requirement R5 for more than 60 percent but less than or equal to 70 percent of the required BES Elements included in Part 5.1.	The Reliability Coordinator identified the BES Elements for which DDR data is required as directed by Requirement R5 for less than or equal to 60 percent of the required BES Elements included in Part 5.1.  OR

			<p>OR</p> <p>The Reliability Coordinator identified the BES Elements for DDR as directed by Requirement R5, Part 5.1 or Part 5.4 but was late by 30-calendar days or less.</p> <p>OR</p> <p>The Reliability Coordinator as directed by Requirement R5, Part 5.3 was late in notifying the owners by 10-calendar days or less.</p>	<p>OR</p> <p>The Reliability Coordinator identified the BES Elements for DDR as directed by Requirement R5, Part 5.1 or Part 5.4 but was late by greater than 30-calendar days and less than or equal to 60 -calendar days.</p> <p>OR</p> <p>The Reliability Coordinator as directed by Requirement R5, Part 5.3 was late in notifying the owners by greater than 10-calendar days but less than or equal to 20-calendar days.</p>	<p>OR</p> <p>The Reliability Coordinator identified the BES Elements for DDR as directed by Requirement R5, Part 5.1 or Part 5.4 but was late by greater than 60-calendar days and less than or equal to 90-calendar days.</p> <p>OR</p> <p>The Reliability Coordinator as directed by Requirement R5, Part 5.3 was late in notifying the owners by greater than 20-calendar days but less than or equal to 30-calendar days.</p>	<p>The Reliability Coordinator identified the BES Elements for DDR as directed by Requirement R5, Part 5.1 or Part 5.4 but was late by greater than 90-calendar days.</p> <p>OR</p> <p>The Reliability Coordinator as directed by Requirement R5, Part 5.3 was late in notifying one or more owners by greater than 30-calendar days.</p> <p>OR</p> <p>The Reliability Coordinator failed to ensure a minimum DDR coverage per Part 5.2.</p>
<b>R6</b>	Long-term Planning	Lower	The Transmission Owner had DDR data as directed by Requirement R6, Parts 6.1 through 6.4 that covered more than 80	The Transmission Owner had DDR data as directed by Requirement R6, Parts 6.1 through 6.4 for more than 70 percent	The Transmission Owner had DDR data as directed by Requirement R6, Parts 6.1 through 6.4 for more than 60 percent	The Transmission Owner failed to have DDR data as directed by Requirement R6, Parts 6.1 through 6.4.

			percent but less than 100 percent of the total required electrical quantities for all applicable BES Elements.	but less than or equal to 80 percent of the total required electrical quantities for all applicable BES Elements.	but less than or equal to 70 percent of the total required electrical quantities for all applicable BES Elements.	
<b>R7</b>	Long-term Planning	Lower	The Generator Owner had DDR data as directed by Requirement R7, Parts 7.1 through 7.4 that covers more than 80 percent but less than 100 percent of the total required electrical quantities for all applicable BES Elements.	The Generator Owner had DDR data as directed by Requirement R7, Parts 7.1 through 7.4 for more than 70 percent but less than or equal to 80 percent of the total required electrical quantities for all applicable BES Elements.	The Generator Owner had DDR data as directed by Requirement R7, Parts 7.1 through 7.4 for more than 60 percent but less than or equal to 70 percent of the total required electrical quantities for all applicable BES Elements.	The Generator Owner failed to have DDR data as directed by Requirement R7, Parts 7.1 through 7.4.
<b>R8</b>	Long-term Planning	Lower	The Transmission Owner or Generator Owner had continuous or non-continuous DDR data, as directed in Requirement R8, for more than 80 percent but less than 100 percent of the BES Elements they own as	The Transmission Owner or Generator Owner had continuous or non-continuous DDR data, as directed in Requirement R8, for more than 70 percent but less than or equal to 80 percent of the BES Elements they	The Transmission Owner or Generator Owner had continuous or non-continuous DDR data, as directed in Requirement R8, for more than 60 percent but less than or equal to 70 percent of the BES Elements they	The Transmission Owner or Generator Owner failed to have continuous or non-continuous DDR data, as directed in Requirement R8, for the BES Elements they own as determined in Requirement R5.

			determined in Requirement R5.	own as determined in Requirement R5.	own as determined in Requirement R5.	
<b>R9</b>	Long-term Planning	Lower	The Transmission Owner or Generator Owner had DDR data that meets more than 80 percent but less than 100 percent of the total recording properties as specified in Requirement R9.	The Transmission Owner or Generator Owner had DDR data that meets more than 70 percent but less than or equal to 80 percent of the total recording properties as specified in Requirement R9.	The Transmission Owner or Generator Owner had DDR data that meets more than 60 percent but less than or equal to 70 percent of the total recording properties as specified in Requirement R9.	The Transmission Owner or Generator Owner had DDR data that meets less than or equal to 60 percent of the total recording properties as specified in Requirement R9.
<b>R10</b>	Long-term Planning	Lower	The Transmission Owner or Generator Owner had time synchronization per Requirement R10, Parts 10.1 and 10.2 for SER, FR, and DDR data for more than 90 percent but less than 100 percent of the BES buses identified in Requirement R1 and BES Elements identified in Requirement R5 as directed by Requirement R10.	The Transmission Owner or Generator Owner had time synchronization per Requirement R10, Parts 10.1 and 10.2 for SER, FR, and DDR data for more than 80 percent but less than or equal to 90 percent of the BES buses identified in Requirement R1 and BES Elements identified in Requirement R5 as	The Transmission Owner or Generator Owner had time synchronization per Requirement R10, Parts 10.1 and 10.2 for SER, FR, and DDR data for more than 70 percent but less than or equal to 80 percent of the BES buses identified in Requirement R1 and BES Elements identified in Requirement R5 as	The Transmission Owner or Generator Owner failed to have time synchronization per Requirement R10, Parts 10.1 and 10.2 for SER, FR, and DDR data for less than or equal to 70 percent of the BES buses identified in Requirement R1 and BES Elements identified in Requirement R5 as directed by Requirement R10.

				directed by Requirement R10.	directed by Requirement R10.	
<b>R11</b>	Long-term Planning	Lower	<p>The Transmission Owner or Generator Owner as directed by Requirement R11, Part 11.1 provided the requested data more than 30-calendar days but less than 40-calendar days after the request unless an extension was granted by the requesting authority.</p> <p>OR</p> <p>The Transmission Owner or Generator</p>	<p>The Transmission Owner or Generator Owner as directed by Requirement R11, Part 11.1 provided the requested data more than 40-calendar days but less than or equal to 50-calendar days after the request unless an extension was granted by the requesting authority.</p> <p>OR</p> <p>The Transmission Owner or Generator</p>	<p>The Transmission Owner or Generator Owner as directed by Requirement R11, Part 11.1 provided the requested data more than 50-calendar days but less than or equal to 60-calendar days after the request unless an extension was granted by the requesting authority.</p> <p>OR</p> <p>The Transmission Owner or Generator</p>	<p>The Transmission Owner or Generator Owner as directed by Requirement R11, Part 11.1 failed to provide the requested data more than 60-calendar days after the request unless an extension was granted by the requesting authority.</p> <p>OR</p> <p>The Transmission Owner or Generator Owner as directed by Requirement R11</p>

			<p>Owner as directed by Requirement R11 provided more than 90 percent but less than 100 percent of the requested data.</p> <p>OR</p> <p>The Transmission Owner or Generator Owner as directed by Requirement R11, Parts 11.3 through 11.5 provided more than 90 percent of the data but less than 100 percent of the data in the proper data format.</p>	<p>Owner as directed by Requirement R11 provided more than 80 percent but less than or equal to 90 percent of the requested data.</p> <p>OR</p> <p>The Transmission Owner or Generator Owner as directed by Requirement R11, Parts 11.3 through 11.5 provided more than 80 percent of the data but less than or equal to 90 percent of the data in the proper data format.</p>	<p>Owner as directed by Requirement R11 provided more than 70 percent but less than or equal to 80 percent of the requested data.</p> <p>OR</p> <p>The Transmission Owner or Generator Owner as directed by Requirement R11, Parts 11.3 through 11.5 provided more than 70 percent of the data but less than or equal to 80 percent of the data in the proper data format.</p>	<p>failed to provide less than or equal to 70 percent of the requested data.</p> <p>OR</p> <p>The Transmission Owner or Generator Owner as directed by Requirement R11, Parts 11.3 through 11.5 provided less than or equal to 70 percent of the data in the proper data format.</p>
<b>R12</b>	Long-term Planning	Lower	<p>The Transmission Owner or Generator Owner as directed by Requirement R12 reported a failure and provided a Corrective Action Plan to the Regional Entity more than 90-calendar days but less than or equal</p>	<p>The Transmission Owner or Generator Owner as directed by Requirement R12 reported a failure and provided a Corrective Action Plan to the Regional Entity more than 100-calendar days but less than or</p>	<p>The Transmission Owner or Generator Owner as directed by Requirement R12 reported a failure and provided a Corrective Action Plan to the Regional Entity more than 110-calendar days but less than or</p>	<p>The Transmission Owner or Generator Owner as directed by Requirement R12 failed to report a failure and provide a Corrective Action Plan to the Regional Entity more than 120-calendar days after</p>

			to 100-calendar days after discovery of the failure.	equal to 110-calendar days after discovery of the failure.	equal to 120-calendar days after discovery of the failure.  OR The Transmission Owner or Generator Owner as directed by Requirement R12 submitted a CAP to the Regional Entity but failed to implement it.	discovery of the failure.  OR Transmission Owner or Generator Owner as directed by Requirement R12 failed to restore the recording capability and failed to submit a CAP to the Regional Entity.
--	--	--	--	--	---	---



## D. Regional Variances

None.

## E. Interpretations

None.

## F. Associated Documents

None.

## G. References

IEEE C37.111: Common format for transient data exchange (COMTRADE) for power Systems.

IEEE C37.232-2011, IEEE Standard for Common Format for Naming Time Sequence Data Files (COMNAME). Standard published 11/09/2011 by IEEE.

NPCC SP6 Report Synchronized Event Data Reporting, revised March 31, 2005

U.S.-Canada Power System Outage Task Force, Final Report on the August 14, 2003 Blackout in the United States and Canada: Causes and Recommendations (2004).

U.S.-Canada Power System Outage Task Force Interim Report: Causes of the August 14th Blackout in the United States and Canada (Nov. 2003)

## Version History

Version	Date	Action	Change Tracking
0	February 8, 2005	Adopted by NERC Board of Trustees	New
1	August 2, 2006	Adopted by NERC Board of Trustees	Revised
2	November 13, 2014	Adopted by NERC Board of Trustees	Revised under Project 2007-11 and merged with PRC-018-1.
2	September 24, 2015	FERC approved PRC-005-4. Docket No. RM15-4-000; Order No. 814	
3	May 13, 2021	Adopted by NERC Board of Trustees	Revised under Project 2015-09

## Attachment 1

### Methodology for Selecting Buses for Capturing Sequence of Events Recording (SER) and Fault Recording (FR) Data

#### (Requirement R1)

To identify monitored BES buses for sequence of events recording (SER) and Fault recording (FR) data required by Requirement 1, each Transmission Owner shall follow sequentially, unless otherwise noted, the steps listed below:

Step 1. Determine a complete list of BES buses that it owns.

For the purposes of this standard, a single BES bus includes physical buses with breakers connected at the same voltage level within the same physical location sharing a common ground grid. These buses may be modeled or represented by a single node in fault studies. For example, ring bus or breaker-and-a-half bus configurations are considered to be a single bus.

Step 2. Reduce the list to those BES buses that have a maximum available calculated three phase short circuit MVA of 1,500 MVA or greater. If there are no buses on the resulting list, proceed to Step 7.

Step 3. Determine the 11 BES buses on the list with the highest maximum available calculated three phase short circuit MVA level. If the list has 11 or fewer buses, proceed to Step 7.

Step 4. Calculate the median MVA level of the 11 BES buses determined in Step 3.

Step 5. Multiply the median MVA level determined in Step 4 by 20 percent.

Step 6. Reduce the BES buses on the list to only those that have a maximum available calculated three phase short circuit MVA higher than the greater of:

- 1,500 MVA or
- 20 percent of median MVA level determined in Step 5.

Step 7. If there are no BES buses on the list: the procedure is complete and no FR and SER data will be required. Proceed to Step 9.

If the list has 1 or more but less than or equal to 11 BES buses: FR and SER data is required at the BES bus with the highest maximum available calculated three phase short circuit MVA as determined in Step 3. Proceed to Step 9.

If the list has more than 11 BES buses: SER and FR data is required on at least the 10 percent of the BES buses determined in Step 6 with the highest maximum available calculated three phase short circuit MVA. Proceed to Step 8.

Step 8. SER and FR data is required at additional BES buses on the list determined in Step 6. The aggregate of the number of BES buses determined in Step 7 and this Step will be at least 20 percent of the BES buses determined in Step 6.

The additional BES buses are selected, at the Transmission Owner's discretion, to provide maximum wide-area coverage for SER and FR data. The following BES bus locations are recommended:

- Electrically distant buses or electrically distant from other DME devices.
- Voltage sensitive areas.
- Cohesive load and generation zones.
- BES buses with a relatively high number of incident Transmission circuits.
- BES buses with reactive power devices.
- Major Facilities interconnecting outside the Transmission Owner's area.

Step 9. The list of monitored BES buses for SER and FR data for Requirement R1 is the aggregate of the BES buses determined in Steps 7 and 8.

**Attachment 2**  
**Sequence of Events Recording (SER) Data Format**  
**(Requirement R11, Part 11.3)**

Date, Time, Local Time Code, Substation, Device, State<sup>1</sup>

08/27/13, 23:58:57.110, -5, Sub 1, Breaker 1, Close

08/27/13, 23:58:57.082, -5, Sub 2, Breaker 2, Close

08/27/13, 23:58:47.217, -5, Sub 1, Breaker 1, Open

08/27/13, 23:58:47.214, -5, Sub 2, Breaker 2, Open

---

<sup>1</sup> "OPEN" and "CLOSE" are used as examples. Other terminology such as TRIP, TRIP TO LOCKOUT, RECLOSE, etc. is also acceptable.

### High Level Requirement Overview

Requirement	Entity	Identify BES Buses	Notification	SER	FR	5 Year Re-evaluation
R1	TO	X	X	X	X	X
R2	TO   GO			X		
R3	TO   GO				X	
R4	TO   GO				X	
Requirement	Entity	Identify BES Elements	Notification	DDR	5 Year Re-evaluation	
R5	RC	X	X	X	X	
R6	TO			X		
R7	GO			X		
R8	TO   GO			X		
R9	TO   GO			X		
Requirement	Entity	Time Synchronization	Provide SER, FR, DDR Data		SER, FR, DDR Availability	
R10	TO   GO	X				
R11	TO   GO		X			
R12	TO   GO				X	

### **Rationale:**

During development of this standard, text boxes were embedded within the standard to explain the rationale for various parts of the standard. Upon BOT approval, the text from the rationale text boxes was moved to this section.

### **Rationale for Functional Entities:**

Because the Reliability Coordinator has the best wide-area view of the BES, the Reliability Coordinator is most suited to be responsible for determining the BES Elements for which dynamic Disturbance recording (DDR) data is required. The Transmission Owners and Generator Owners will have the responsibility for ensuring that adequate data is available for those BES Elements selected.

BES buses where sequence of events recording (SER) and fault recording (FR) data is required are best selected by Transmission Owners because they have the required tools, information, and working knowledge of their Systems to determine those buses. The Transmission Owners and Generator Owners that own BES Elements on those BES buses will have the responsibility for ensuring that adequate data is available.

### **Rationale for R1:**

Analysis and reconstruction of BES events requires SER and FR data from key BES buses. Attachment 1 provides a uniform methodology to identify those BES buses. Repeated testing of the Attachment 1 methodology has demonstrated the proper distribution of SER and FR data collection. Review of actual BES short circuit data received from the industry in response to the DMSDT's data request (June 5, 2013 through July 5, 2013) illuminated a strong correlation between the available short circuit MVA at a Transmission bus and its relative size and importance to the BES based on (i) its voltage level, (ii) the number of Transmission Lines and other BES Elements connected to the BES bus, and (iii) the number and size of generating units connected to the bus. BES buses with a large short circuit MVA level are BES Elements that have a significant effect on System reliability and performance. Conversely, BES buses with very low short circuit MVA levels seldom cause wide-area or cascading System events, so SER and FR data from those BES Elements are not as significant. After analyzing and reviewing the collected data submittals from across the continent, the threshold MVA values were chosen to provide sufficient data for event analysis using engineering and operational judgment.

Concerns have existed that the defined methodology for bus selection will overly concentrate data to selected BES buses. For the purpose of PRC-002-3, there are a minimum number of BES buses for which SER and FR data is required based on the short circuit level. With these concepts and the objective being sufficient recording coverage for event analysis, the DMSDT developed the procedure in Attachment 1 that utilizes the maximum available calculated three phase short circuit MVA. This methodology ensures comparable and sufficient coverage for SER and FR data regardless of variations in the size and System topology of Transmission Owners across all Interconnections. Additionally, this methodology provides a degree of flexibility for the use of judgment in the selection process to ensure sufficient distribution.

BES buses where SER and FR data is required are best selected by Transmission Owners because they have the required tools, information, and working knowledge of their Systems to determine those buses.

Each Transmission Owner must re-evaluate the list of BES buses at least every five calendar years to address System changes since the previous evaluation. Changes to the BES do not mandate immediate inclusion of BES buses into the currently enforced list, but the list of BES buses will be re-evaluated at least every five calendar years to address System changes since the previous evaluation.

Since there may be multiple owners of equipment that comprise a BES bus, the notification required in R1 is necessary to ensure all owners are notified.

A 90-calendar day notification deadline provides adequate time for the Transmission Owner to make the appropriate determination and notification.

**Rationale for R2:**

The intent is to capture SER data for the status (open/close) of the circuit breakers that can interrupt the current flow through each BES Element connected to a BES bus. Change of state of circuit breaker position, time stamped according to Requirement R10 to a time synchronized clock, provides the basis for assembling the detailed sequence of events timeline of a power System Disturbance. Other status monitoring nomenclature can be used for devices other than circuit breakers.

**Rationale for R3:**

The required electrical quantities may either be directly measured or determinable if sufficient FR data is captured (e.g. residual or neutral current if the phase currents are directly measured). In order to cover all possible fault types, all BES bus phase-to-neutral voltages are required to be determinable for each BES bus identified in Requirement R1. BES bus voltage data is adequate for System Disturbance analysis. Phase current and residual current are required to distinguish between phase faults and ground faults. It also facilitates determination of the fault location and cause of relay operation. For transformers (Part 3.2.1), the data may be from either the high-side or the low-side of the transformer. Generator step-up transformers (GSUs) and leads that connect the GSU transformer(s) to the Transmission System that are used exclusively to export energy directly from a BES generating unit or generating plant are excluded from Requirement R3 because the fault current contribution from a generator to a fault on the Transmission System will be captured by FR data on the Transmission System, and Transmission System FR will capture faults on the generator interconnection.

Generator Owners may install this capability or, where the Transmission Owners already have suitable FR data, contract with the Transmission Owner. However, when required, the Generator Owner is still responsible for the provision of this data.

**Rationale for R4:**

Time stamped pre- and post-trigger fault data aid in the analysis of power System operations and determination if operations were as intended. System faults generally persist for a short time period, thus a 30-cycle total minimum record length is adequate. Multiple records allow for legacy microprocessor relays which, when time-synchronized, are capable of providing adequate fault data but not capable of providing fault data in a single record with 30-contiguous cycles total.

A minimum recording rate of 16 samples per cycle (960 Hz) is required to get sufficient point on wave data for recreating accurate fault conditions.

**Rationale for R5:**

DDR is used for capturing the BES transient and post-transient response following Disturbances, and the data is used for event analysis and validating System performance. DDR plays a critical role in wide-area Disturbance analysis, and Requirement R5 ensures there is adequate wide-area coverage of DDR data for specific BES Elements to facilitate accurate and efficient event analysis. The Reliability Coordinator has the best wide-area view of the System and needs to ensure that there are sufficient BES Elements identified for DDR data capture. The identification of BES Elements requiring DDR data as per Requirement R5 is based upon industry experience with wide-area Disturbance analysis and the need for adequate data to facilitate event analysis. Ensuring data is captured for these BES Elements will significantly improve the accuracy of analysis and understanding of why an event occurred, not simply what occurred.

From its experience with changes to the Bulk Electric System that would affect DDR, the DMSDT decided that the five calendar year re-evaluation of the list is a reasonable interval for this review. Changes to the BES do not mandate immediate inclusion of BES Elements into the in force list, but the list of BES Elements will be re-evaluated at least every five calendar years to address System changes since the previous evaluation. However, this standard does not preclude the Reliability Coordinator from performing this re-evaluation more frequently to capture updated BES Elements.

The Reliability Coordinator must notify all owners of the selected BES Elements that DDR data is required for this standard. The Reliability Coordinator is only required to share the list of selected BES Elements that each Transmission Owner and Generator Owner respectively owns, not the entire list. This communication of selected BES Elements is required to ensure that the owners of the respective BES Elements are aware of their responsibilities under this standard.

Implementation of the monitoring equipment is the responsibility of the respective Transmission Owners and Generator Owners, the timeline for installing this capability is outlined in the Implementation Plan, and starts from notification of the list from the Reliability Coordinator. Data for each BES Element as defined by the Reliability Coordinator must be provided; however, this data can be either directly measured or accurately calculated. With the exception of HVDC circuits, DDR data is only required for one end or terminal of the BES Elements selected. For example, DDR data must be provided for at least one terminal of a



Transmission Line or generator step-up (GSU) transformer, but not both terminals. For an interconnection between two Reliability Coordinators, each Reliability Coordinator will consider this interconnection independently, and are expected to work cooperatively to determine how to monitor the BES Elements that require DDR data. For an interconnection between two TO's, or a TO and a GO, the Reliability Coordinator will determine which entity will provide the data. The Reliability Coordinator will notify the owners that their BES Elements require DDR data.

Refer to the Guidelines and Technical Basis Section for more detail on the rationale and technical reasoning for each identified BES Element in Requirement R5, Part 5.1; monitoring these BES Elements with DDR will facilitate thorough and informative event analysis of wide-area Disturbances on the BES. Part 5.2 is included to ensure wide-area coverage across all Reliability Coordinators. It is intended that each Reliability Coordinator will have DDR data for one BES Element and at least one additional BES Element per 3,000 MW of its historical simultaneous peak System Demand.

**Rationale for R6:**

DDR is used to measure transient response to System Disturbances during a relatively balanced post-fault condition. Therefore, it is sufficient to provide a phase-to-neutral voltage or positive sequence voltage. The electrical quantities can be determined (calculated, derived, etc.).

Because all of the BES buses within a location are at the same frequency, one frequency measurement is adequate.

The data requirements for PRC-002-3 are based on a System configuration assuming all normally closed circuit breakers on a BES bus are closed.

**Rationale for R7:**

A crucial part of wide-area Disturbance analysis is understanding the dynamic response of generating resources. Therefore, it is necessary for Generator Owners to have DDR at either the high- or low-side of the generator step-up transformer (GSU) measuring the specified electrical quantities to adequately capture generator response. This standard defines the 'what' of DDR, not the 'how'. Generator Owners may install this capability or, where the Transmission Owners already have suitable DDR data, contract with the Transmission Owner. However, the Generator Owner is still responsible for the provision of this data.

**Rationale for R8:**

Large scale System outages generally are an evolving sequence of events that occur over an extended period of time, making DDR data essential for event analysis. Data available pre- and post-contingency helps identify the causes and effects of each event leading to outages. Therefore, continuous recording and storage are necessary to ensure sufficient data is available for the entire event.

Existing DDR data recording across the BES may not record continuously. To accommodate its use for the purposes of this standard, triggered records are acceptable if the equipment was installed prior to the effective date of this standard. The frequency triggers are defined based on the dynamic response associated with each Interconnection. The undervoltage trigger is

defined to capture possible delayed undervoltage conditions such as Fault Induced Delayed Voltage Recovery (FIDVR).

**Rationale for R9:**

An input sampling rate of at least 960 samples per second, which corresponds to 16 samples per cycle on the input side of the DDR equipment, ensures adequate accuracy for calculation of recorded measurements such as complex voltage and frequency.

An output recording rate of electrical quantities of at least 30 times per second refers to the recording and measurement calculation rate of the device. Recorded measurements of at least 30 times per second provide adequate recording speed to monitor the low frequency oscillations typically of interest during power System Disturbances.

**Rationale for R10:**

Time synchronization of Disturbance monitoring data is essential for time alignment of large volumes of geographically dispersed records from diverse recording sources. Coordinated Universal Time (UTC) is a recognized time standard that utilizes atomic clocks for generating precision time measurements. All data must be provided in UTC formatted time either with or without the local time offset, expressed as a negative number (the difference between UTC and the local time zone where the measurements are recorded).

Accuracy of time synchronization applies only to the clock used for synchronizing the monitoring equipment. The equipment used to measure the electrical quantities must be time synchronized to  $\pm 2$  ms accuracy; however, accuracy of the application of this time stamp and therefore the accuracy of the data itself is not mandated. This is because of inherent delays associated with measuring the electrical quantities and events such as breaker closing, measurement transport delays, algorithm and measurement calculation techniques, etc. Ensuring that the monitoring devices internal clocks are within  $\pm 2$  ms accuracy will suffice with respect to providing time synchronized data.

**Rationale for R11:**

Wide-area Disturbance analysis includes data recording from many devices and entities. Standardized formatting and naming conventions of these files significantly improves timely analysis.

Providing the data within 30-calendar days (or the granted extension time), subject to Part 11.1, allows for reasonable time to collect the data and perform any necessary computations or formatting.

Data is required to be retrievable for 10-calendar days inclusive of the day the data was recorded, i.e. a 10-calendar day rolling window of available data. Data hold requests are usually initiated the same or next day following a major event for which data is requested. A 10-calendar day time frame provides a practical limit on the duration of data required to be stored and informs the requesting entities as to how long the data will be available. The requestor of

data has to be aware of the Part 11.1 10-calendar day retrievability because requiring data retention for a longer period of time is expensive and unnecessary.

SER data shall be provided in a simple ASCII .CSV format as outlined in Attachment 2. Either equipment can provide the data or a simple conversion program can be used to convert files into this format. This will significantly improve the data format for event records, enabling the use of software tools for analyzing the SER data.

Part 11.4 specifies FR and DDR data files be provided in conformance with IEEE C37.111, IEEE Standard for Common Format for Transient Exchange (COMTRADE), revision 1999 or later. The use of IEEE C37.111-1999 or later is well established in the industry. C37.111-2013 is a version of COMTRADE that includes an annex describing the application of the COMTRADE standard to synchrophasor data; however, version C37.111-1999 is commonly used in the industry today.

Part 11.5 uses a standardized naming format, C37.232-2011, IEEE Standard for Common Format for Naming Time Sequence Data Files (COMNAME), for providing Disturbance monitoring data. This file format allows a streamlined analysis of large Disturbances, and includes critical records such as local time offset associated with the synchronization of the data.

**Rationale for R12:**

Each Transmission Owner and Generator Owner who owns equipment used for collecting the data required for this standard must repair any failures within 90-calendar days to ensure that adequate data is available for event analysis. If the Disturbance monitoring capability cannot be restored within 90-calendar days (e.g. budget cycle, service crews, vendors, needed outages, etc.), the entity must develop a Corrective Action Plan (CAP) for restoring the data recording capability. The timeline required for the CAP depends on the entity and the type of data required. It is treated as a failure if the recording capability is out of service for maintenance and/or testing for greater than 90-calendar days. An outage of the monitored BES Element does not constitute a failure of the Disturbance monitoring capability.

## Guidelines and Technical Basis Section

### Introduction

The emphasis of PRC-002-3 is not on how Disturbance monitoring data is captured, but what Bulk Electric System data is captured. There are a variety of ways to capture the data PRC-002-3 addresses, and existing and currently available equipment can meet the requirements of this standard. PRC-002-3 also addresses the importance of addressing the availability of Disturbance monitoring capability to ensure the completeness of BES data capture.

The data requirements for PRC-002-3 are based on a System configuration assuming all normally closed circuit breakers on a bus are closed.

PRC-002-3 addresses “what” data is recorded, not “how” it is recorded.

### Guideline for Requirement R1:

Sequence of events and fault recording for the analysis, reconstruction, and reporting of System Disturbances is important. However, SER and FR data is not required at every BES bus on the BES to conduct adequate or thorough analysis of a Disturbance. As major tools of event analysis, the time synchronized time stamp for a breaker change of state and the recorded waveforms of voltage and current for individual circuits allows the precise reconstruction of events of both localized and wide-area Disturbances.

More quality information is always better than less when performing event analysis. However, 100 percent coverage of all BES Elements is not practical nor required for effective analysis of wide-area Disturbances. Therefore, selectivity of required BES buses to monitor is important for the following reasons:

1. Identify key BES buses with breakers where crucial information is available when required.
2. Avoid excessive overlap of coverage.
3. Avoid gaps in critical coverage.
4. Provide coverage of BES Elements that could propagate a Disturbance.
5. Avoid mandates to cover BES Elements that are more likely to be a casualty of a Disturbance rather than a cause.
6. Establish selection criteria to provide effective coverage in different regions of the continent.

The major characteristics available to determine the selection process are:

1. System voltage level;
2. The number of Transmission Lines into a substation or switchyard;
3. The number and size of connected generating units;
4. The available short circuit levels.

Although it is straightforward to establish criteria for the application of identified BES buses, analysis was required to establish a sound technical basis to fulfill the required objectives.

To answer these questions and establish criteria for BES buses of SER and FR, the DMSDT established a sub-team referred to as the Monitored Value Analysis Team (MVA Team). The MVA Team collected information from a wide variety of Transmission Systems throughout the continent to analyze Transmission buses by the characteristics previously identified for the selection process.

The MVA Team learned that the development of criteria is not possible for adequate SER and FR coverage, based solely upon simple, bright line characteristics, such as the number of lines into a substation or switchyard at a particular voltage level or at a set level of short circuit current. To provide the appropriate coverage, a relatively simple but effective Methodology for Selecting Buses for Capturing Sequence of Events Recording (SER) and Fault Recording (FR) Data was developed. This Procedure, included as Attachment 1, assists entities in fulfilling Requirement R1 of the standard.

The Methodology for Selecting Buses for Capturing Sequence of Events Recording (SER) and Fault Recording (FR) Data is weighted to buses with higher short circuit levels. This is chosen for the following reasons:

1. The method is voltage level independent.
2. It is likely to select buses near large generation centers.
3. It is likely to select buses where delayed clearing can cause Cascading.
4. Selected buses directly correlate to the Universal Power Transfer equation: Lower Impedance – increased power flows – greater System impact.

To perform the calculations of Attachment 1, the following information below is required and the following steps (provided in summary form) are required for Systems with more than 11 BES buses with three phase short circuit levels above 1,500 MVA.

1. Total number of BES buses in the Transmission System under evaluation.
  - a. Only tangible substation or switchyard buses are included.
  - b. Pseudo buses created for analysis purposes in System models are excluded.
2. Determine the three phase short circuit MVA for each BES bus.
3. Exclude BES buses from the list with short circuit levels below 1,500 MVA.
4. Determine the median short circuit for the top 11 BES buses on the list (position number 6).
5. Multiply median short circuit level by 20 percent.
6. Reduce the list of BES buses to those with short circuit levels higher than 20 percent of the median.
7. Apply SER and FR at BES buses with short circuit levels in the top 10 percent of the list (from 6).

8. Apply SER and FR at BES buses at an additional 10 percent of the list using engineering judgment, and allowing flexibility to factor in the following considerations:
  - Electrically distant BES buses or electrically distant from other DME devices
  - Voltage sensitive areas
  - Cohesive load and generation zones
  - BES buses with a relatively high number of incident Transmission circuits
  - BES buses with reactive power devices
  - Major facilities interconnecting outside the Transmission Owner's area.

For event analysis purposes, more valuable information is attained about generators and their response to System events pre- and post-contingency through DDR data versus SER or FR records. SER data of the opening of the primary generator output interrupting devices (e.g. synchronizing breaker) may not reliably indicate the actual time that a generator tripped; for instance, when it trips on reverse power after loss of its prime mover (e.g. combustion or steam turbine). As a result, this standard only requires DDR data.

The re-evaluation interval of five years was chosen based on the experience of the DMSDT to address changing System configurations while creating balance in the frequency of re-evaluations.

**Guideline for Requirement R2:**

Analyses of wide-area Disturbances often begin by evaluation of SERs to help determine the initiating event(s) and follow the Disturbance propagation. Recording of breaker operations help determine the interruption of line flows while generator loading is best determined by DDR data, since generator loading can be essentially zero regardless of breaker position. However, generator breakers directly connected to an identified BES bus are required to have SER data captured. It is important in event analysis to know when a BES bus is cleared regardless of a generator's loading.

Generator Owners are included in this requirement because a Generator Owner may, in some instances, own breakers directly connected to the Transmission Owner's BES bus.

**Guideline for Requirement R3:**

The BES buses for which FR data is required are determined based on the methodology described in Attachment 1 of the standard. The BES Elements connected to those BES buses for which FR data is required include:

- Transformers with a low-side operating voltage of 100kV or above
- Transmission Lines

Only those BES Elements that are identified as BES as defined in the latest in effect NERC definition are to be monitored. For example, radial lines or transformers with low-side voltage less than 100kV are not included.

FR data must be determinable from each terminal of a BES Element connected to applicable BES buses.

Generator step-up transformers (GSU) are excluded from the above based on the following:

- Current contribution from a generator in case of fault on the Transmission System will be captured by FR data on the Transmission System.
- For faults on the interconnection to generating facilities it is sufficient to have fault current data from the Transmission station end of the interconnection. Current contribution from a generator can be readily calculated if needed.

The DMSDT, after consulting with NERC's Event Analysis group, determined that DDR data from selected generator locations was more important for event analysis than FR data.

#### Recording of Electrical Quantities

For effective fault analysis it is necessary to know values of all phase and neutral currents and all phase-to-neutral voltages. Based on such FR data it is possible to determine all fault types. FR data also augments SERs in evaluating circuit breaker operation.

#### Current Recordings

The required electrical quantities are normally directly measured. Certain quantities can be derived if sufficient data is measured, for example residual or neutral currents.

Since a Transmission System is generally well balanced, with phase currents having essentially similar magnitudes and phase angle differences of 120°, during normal conditions there is negligible neutral (residual) current. In case of a ground fault the resulting phase current imbalance produces residual current that can be either measured or calculated.

Neutral current, also known as ground or residual current  $I_r$ , is calculated as a sum of vectors of three phase currents:

$$I_r = 3 \cdot I_0 = I_A + I_B + I_C$$

$I_0$  - Zero-sequence current

$I_A, I_B, I_C$  - Phase current (vectors)

Another example of how required electrical quantities can be derived is based on Kirchhoff's Law. Fault currents for one of the BES Elements connected to a particular BES bus can be derived as a vectorial sum of fault currents recorded at the other BES Elements connected to that BES bus.

#### Voltage Recordings

Voltages are to be recorded or accurately determined at applicable BES buses.

#### **Guideline for Requirement R4:**

Pre- and post-trigger fault data along with the SER breaker data, all time stamped to a common clock at millisecond accuracy, aid in the analysis of protection System operations after a fault to determine if a protection System operated as designed. Generally speaking, BES faults persist for a very short time period, approximately 1 to 30 cycles, thus a 30-cycle record length provides adequate data. Multiple records allow for legacy microprocessor relays which, when time synchronized to a common clock, are capable of providing adequate fault data but not capable of providing fault data in a single record with 30-contiguous cycles total.

A minimum recording rate of 16 samples per cycle is required to get accurate waveforms and to get 1 millisecond resolution for any digital input which may be used for FR.

FR triggers can be set so that when the monitored value on the recording device goes above or below the trigger value, data is recorded. Requirement R4, sub-Part 4.3.1 specifies a neutral (residual) overcurrent trigger for ground faults. Requirement R4, sub-Part 4.3.2 specifies a phase undervoltage or overcurrent trigger for phase-to-phase faults.

#### **Guideline for Requirement R5:**

DDR data is used for wide-area Disturbance monitoring to determine the System's electromechanical transient and post-transient response and validate System model performance. DDR is typically located based on strategic studies which include angular, frequency, voltage, and oscillation stability. However, for adequately monitoring the System's dynamic response and ensuring sufficient coverage to determine System performance, DDR is required for key BES Elements in addition to a minimum requirement of DDR coverage.

Each Reliability Coordinator is required to identify sufficient DDR data capture for, at a minimum, one BES Element and then one additional BES Element per 3,000 MW of historical simultaneous peak System Demand. This DDR data is included to provide adequate System wide coverage across an Interconnection. To clarify, if any of the key BES Elements requiring DDR monitoring are within the Reliability Coordinator Area, DDR data capability is required. If a Reliability Coordinator does not meet the requirements of Part 5.1, additional coverage had to be specified.

Loss of large generating resources poses a frequency and angular stability risk for all Interconnections across North America. Data capturing the dynamic response of these machines during a Disturbance helps the analysis of large Disturbances. Having data regarding generator dynamic response to Disturbances greatly improves understanding of **why** an event occurs rather than what occurred. To determine and provide the basis for unit size criteria, the DMSDT acquired specific generating unit data from NERC's Generating Availability Data System (GADS) program. The data contained generating unit size information for each generating unit in North America which was reported in 2013 to the NERC GADS program. The DMSDT analyzed the spreadsheet data to determine: (i) how many units were above or below selected size thresholds; and (ii) the aggregate sum of the ratings of the units within the boundaries of those thresholds. Statistical information about this data was then produced, i.e. averages, means and



percentages. The DMSDT determined the following basic information about the generating units of interest (current North America fleet, i.e. units reporting in 2013) included in the spreadsheet:

- The number of individual generating units in total included in the spreadsheet.
- The number of individual generating units rated at 20 MW or larger included in the spreadsheet. These units would generally require that their owners be registered as GOs in the NERC CMEP.
- The total number of units within selected size boundaries.
- The aggregate sum of ratings, in MWs, of the units within the boundaries of those thresholds.

The information in the spreadsheet does not provide information by which the plant information location of each unit can be determined, i.e. the DMSDT could not use the information to determine which units were located together at a given generation site or facility.

From this information, the DMSDT was able to reasonably speculate the generating unit size thresholds proposed in Requirement R5, sub-Part 5.1.1 of the standard. Generating resources intended for DDR data recording are those individual units with gross nameplate ratings “greater than or equal to 500 MVA”. The 500 MVA individual unit size threshold was selected because this number roughly accounts for 47 percent of the generating capacity in NERC footprint while only requiring DDR coverage on about 12.5 percent of the generating units. As mentioned, there was no data pertaining to unit location for aggregating plant/facility sizes. However, Requirement R5, sub-Part 5.1.1 is included to capture larger units located at large generating plants which could pose a stability risk to the System if multiple large units were lost due to electrical or non-electrical contingencies. For generating plants, each individual generator at the plant/facility with a gross nameplate rating greater than or equal to 300 MVA must have DDR where the gross nameplate rating of the plant/facility is greater than or equal to 1,000 MVA. The 300 MVA threshold was chosen based on the DMSDT’s judgment and experience. The incremental impact to the number of units requiring monitoring is expected to be relatively low. For combined cycle plants where only one generator has a rating greater than or equal to 300MVA, that is the only generator that would need DDR.

Permanent System Operating Limits (SOLs) are used to operate the System within reliable and secure limits. In particular, SOLs related to angular or voltage stability have a significant impact on BES reliability and performance. Therefore, at least one BES Element of an SOL should be monitored.

The draft standard requires “One or more BES Elements that are part of an Interconnection Reliability Operating Limits (IROLs).” Interconnection Reliability Operating Limits (IROLs) are included because the risk of violating these limits poses a risk to System stability and the potential for cascading outages. IROLs may be defined by a single or multiple monitored BES Element(s) and contingent BES Element(s). The standard does not dictate selection of the contingent and/or monitored BES Elements. Rather the Drafting Team believes this

determination is best made by the Reliability Coordinator for each IROL considered based on the severity of violating this IROL.

Locations where an undervoltage load shedding (UVLS) program is deployed are prone to voltage instability since they are generally areas of significant Demand. The Reliability Coordinator will identify these areas where a UVLS is in service and identify a useful and effective BES Element to monitor for DDR such that action of the UVLS or voltage instability on the BES could be captured. For example, a major 500kV or 230kV substation on the EHV System close to the load pocket where the UVLS is deployed would likely be a valuable electrical location for DDR coverage and would aid in post-Disturbance analysis of the load area's response to large System excursions (voltage, frequency, etc.).

**Guideline for Requirement R6:**

DDR data shows transient response to System Disturbances after a fault is cleared (post-fault), under a relatively balanced operating condition. Therefore, it is sufficient to provide a single phase-to-neutral voltage or positive sequence voltage. Recording of all three phases of a circuit is not required, although this may be used to compute and record the positive sequence voltage.

The bus where a voltage measurement is required is based on the list of BES Elements defined by the Reliability Coordinator in Requirement R5. The intent of the standard is not to require a separate voltage measurement of each BES Element where a common bus voltage measurement is available. For example, a breaker-and-a-half or double-bus configuration with a North (or East) Bus and South (or West) Bus, would require both buses to have voltage recording because either can be taken out of service indefinitely with the targeted BES Element remaining in service. This may be accomplished either by recording both bus voltages separately, or by providing a selector switch to connect either of the bus voltage sources to a single recording input of the DDR device. This component of the requirement is therefore included to mitigate the potential of failed frequency, phase angle, real power, and reactive power calculations due to voltage measurements removed from service while sufficient voltage measurement is actually available during these operating conditions.

It must be emphasized that the data requirements for PRC-002-3 are based on a System configuration assuming all normally closed circuit breakers on a bus are closed.

When current recording is required, it should be on the same phase as the voltage recording taken at the location if a single phase-to-neutral voltage is provided. Positive sequence current recording is also acceptable.

For all circuits where current recording is required, Real and Reactive Power will be recorded on a three phase basis. These recordings may be derived either from phase quantities or from positive sequence quantities.

**Guideline for Requirement R7:**

All Guidelines specified for Requirement R6 apply to Requirement R7. Since either the high- or low-side windings of the generator step-up transformer (GSU) may be connected in delta, phase-to-phase voltage recording is an acceptable voltage recording. As was explained in the Guideline for Requirement R6, the BES is operating under a relatively balanced operating condition and, if needed, phase-to-neutral quantities can be derived from phase-to-phase quantities.

Again it must be emphasized that the data requirements for PRC-002-3 are based on a System configuration assuming all normally closed circuit breakers on a bus are closed.

**Guideline for Requirement R8:**

Wide-area System outages are generally an evolving sequence of events that occur over an extended period of time, making DDR data essential for event analysis. Pre- and post-contingency data helps identify the causes and effects of each event leading to the outages. This drives a need for continuous recording and storage to ensure sufficient data is available for the entire Disturbance.

Transmission Owners and Generator Owners are required to have continuous DDR for the BES Elements identified in Requirement R6. However, this requirement recognizes that legacy equipment may exist for some BES Elements that do not have continuous data recording capabilities. For equipment that was installed prior to the effective date of the standard, triggered DDR records of three minutes are acceptable using at least one of the trigger types specified in Requirement R8, Part 8.2:

- Off nominal frequency triggers are used to capture high- or low-frequency excursions of significant size based on the Interconnection size and inertia.
- Rate of change of frequency triggers are used to capture major changes in System frequency which could be caused by large changes in generation or load, or possibly changes in System impedance.
- The undervoltage trigger specified in this standard is provided to capture possible sustained undervoltage conditions such as Fault Induced Delayed Voltage Recovery (FIDVR) events. A sustained voltage of 85 percent is outside normal schedule operating voltages and is sufficiently low to capture abnormal voltage conditions on the BES.

**Guideline for Requirement R9:**

DDR data contains the dynamic response of a power System to a Disturbance and is used for analyzing complex power System events. This recording is typically used to capture short-term and long-term Disturbances, such as a power swing. Since the data of interest is changing over time, DDR data is normally stored in the form of RMS values or phasor values, as opposed to directly sampled data as found in FR data.

The issue of the sampling rate used in a recording instrument is quite important for at least two reasons: the anti-aliasing filter selection and accuracy of signal representation. The anti-aliasing

filter selection is associated with the requirement of a sampling rate at least twice the highest frequency of a sampled signal. At the same time, the accuracy of signal representation is also dependent on the selection of the sampling rate. In general, the higher the sampling rate, the better the representation. In the abnormal conditions of interest (e.g. faults or other Disturbances); the input signal may contain frequencies in the range of 0-400 Hz. Hence, the rate of 960 samples per second (16 samples/cycle) is considered an adequate sampling rate that satisfies the input signal requirements.

In general, dynamic events of interest are: inter-area oscillations, local generator oscillations, wind turbine generator torsional modes, HVDC control modes, exciter control modes, and steam turbine torsional modes. Their frequencies range from 0.1-20 Hz. In order to reconstruct these dynamic events, a minimum recording time of 30 times per second is required.

**Guideline for Requirement R10:**

Time synchronization of Disturbance monitoring data allows for the time alignment of large volumes of geographically dispersed data records from diverse recording sources. A universally recognized time standard is necessary to provide the foundation for this alignment. Coordinated Universal Time (UTC) is the foundation used for the time alignment of records. It is an international time standard utilizing atomic clocks for generating precision time measurements at fractions of a second levels. The local time offset, expressed as a negative number, is the difference between UTC and the local time zone where the measurements are recorded.

Accuracy of time synchronization applies only to the clock used for synchronizing the monitoring equipment.

Time synchronization accuracy is specified in response to Recommendation 12b in the NERC August, 2003, Blackout Final NERC Report Section V Conclusions and Recommendations:

“Recommendation 12b: Facilities owners shall, in accordance with regional criteria, upgrade existing dynamic recorders to include GPS time synchronization...”

Also, from the U.S.-Canada Power System Outage Task Force Interim Report: Causes of the August 14th Blackout, November 2003, in the United States and Canada, page 103:

“Establishing a precise and accurate sequence of outage-related events was a critical building block for the other parts of the investigation. One of the key problems in developing this sequence was that although much of the data pertinent to an event was time-stamped, there was some variance from source to source in how the time-stamping was done, and not all of the time-stamps were synchronized...”

From NPCC’s SP6 Report Synchronized Event Data Reporting, revised March 31, 2005, the investigation by the authoring working group revealed that existing GPS receivers can be expected to provide a time code output which has an uncertainty on the order of 1 millisecond, uncertainty being a quantitative descriptor.

**Guideline for Requirement R11:**

This requirement directs the applicable entities, upon requests from the Reliability Coordinator, Regional Entity or NERC, to provide SER and FR data for BES buses determined in Requirement R1 and DDR data for BES Elements determined as per Requirement R5. To facilitate the analysis of BES Disturbances, it is important that the data is provided to the requestor within a reasonable period of time.

Requirement R11, Part 11.1 specifies the maximum time frame of 30-calendar days to provide the data. Thirty calendar days is a reasonable time frame to allow for the collection of data, and submission to the requestor. An entity may request an extension of the 30-day submission requirement. If granted by the requestor, the entity must submit the data within the approved extended time.

Requirement R11, Part 11.2 specifies that the minimum time period of 10-calendar days inclusive of the day the data was recorded for which the data will be retrievable. With the equipment in use that has the capability of recording data, having the data retrievable for the 10-calendar days is realistic and doable. It is important to note that applicable entities should account for any expected delays in retrieving data and this may require devices to have data available for more than 10 days. To clarify the 10-calendar day time frame, an incident occurs on Day 1. If a request for data is made on Day 6, then that data has to be provided to the requestor within 30-calendar days after a request or a granted time extension. However, if a request for the data is made on Day 11, that is outside the 10-calendar days specified in the requirement, and an entity would not be out of compliance if it did not have the data.

Requirement R11, Part 11.3 specifies a Comma Separated Value (CSV) format according to Attachment 2 for the SER data. It is necessary to establish a standard format as it will be incorporated with other submitted data to provide a detailed sequence of events timeline of a power System Disturbance.

Requirement R11, Part 11.4 specifies the IEEE C37.111 COMTRADE format for the FR and DDR data. The IEEE C37.111 is the Standard for Common Format for Transient Data Exchange and is well established in the industry. It is necessary to specify a standard format as multiple submissions of data from many sources will be incorporated to provide a detailed analysis of a power System Disturbance. The latest revision of COMTRADE (C37.111-2013) includes an annex describing the application of the COMTRADE standard to synchophasor data.

Requirement R11, Part 11.5 specifies the IEEE C37.232 COMNAME format for naming the data files of the SER, FR and DDR. The IEEE C37.232 is the Standard for Common Format for Naming Time Sequence Data Files. The first version was approved in 2007. From the August 14, 2003 blackout there were thousands of Fault Recording data files collected. The collected data files did not have a common naming convention and it was therefore difficult to discern which files came from which utilities and which ones were captured by which devices. The lack of a common naming practice seriously hindered the investigation process. Subsequently, and in its initial report on the blackout, NERC stressed the need for having a common naming practice and listed it as one of its top ten recommendations.

**Guideline for Requirement R12:**

This requirement directs the respective owners of Transmission and Generator equipment to be alert to the proper functioning of equipment used for SER, FR, and DDR data capabilities for the BES buses and BES Elements, which were established in Requirements R1 and R5. The owners are to restore the capability within 90-calendar days of discovery of a failure. This requirement is structured to recognize that the existence of a “reasonable” amount of capability out-of-service does not result in lack of sufficient data for coverage of the System. Furthermore, 90-calendar days is typically sufficient time for repair or maintenance to be performed. However, in recognition of the fact that there may be occasions for which it is not possible to restore the capability within 90-calendar days, the requirement further provides that, for such cases, the entity submit a Corrective Action Plan (CAP) to the Regional Entity and implement it. These actions are considered to be appropriate to provide for robust and adequate data availability.

## A. Introduction

1. **Title:** Disturbance Monitoring and Reporting Requirements
2. **Number:** PRC-002-~~32~~
3. **Purpose:** To have adequate data available to facilitate analysis of Bulk Electric System (BES) Disturbances.
4. **Applicability:**

**Functional Entities:**

**4.1 Reliability Coordinator**~~The Responsible Entity is:~~

~~Eastern Interconnection — Planning Coordinator~~

~~4.1.1 — 4.1.2 ERCOT Interconnection — Planning Coordinator or Reliability Coordinator~~

~~4.1.3 — Western Interconnection — Reliability Coordinator~~

~~4.1.4 — Quebec Interconnection — Planning Coordinator or Reliability Coordinator~~

4.2 Transmission Owner

4.3 Generator Owner

5. **Effective Date:** See Implementation Plan

## B. Requirements and Measures

- R1. Each Transmission Owner shall: [*Violation Risk Factor: Lower*] [*Time Horizon: Long-term Planning*]
  - 1.1. Identify BES buses for which sequence of events recording (SER) and fault recording (FR) data is required by using the methodology in PRC-002-~~23~~, Attachment 1.
  - 1.2. Notify other owners of BES Elements connected to those BES buses, if any, within 90-calendar days of completion of Part 1.1, that those BES Elements require SER data and/or FR data.
  - 1.3. Re-evaluate all BES buses at least once every five calendar years in accordance with Part 1.1 and notify other owners, if any, in accordance with Part 1.2, and implement the re-evaluated list of BES buses as per the Implementation Plan.
- M1. The Transmission Owner has a dated (electronic or hard copy) list of BES buses for which SER and FR data is required, identified in accordance with PRC-002-~~23~~, Attachment 1, and evidence that all BES buses have been re-evaluated within the required intervals under Requirement R1. The Transmission Owner will also have

dated (electronic or hard copy) evidence that it notified other owners in accordance with Requirement R1.

**R2.** Each Transmission Owner and Generator Owner shall have SER data for circuit breaker position (open/close) for each circuit breaker it owns connected directly to the BES buses identified in Requirement R1 and associated with the BES Elements at those BES buses. *[Violation Risk Factor: Lower ] [Time Horizon: Long-term Planning]*

**M2.** The Transmission Owner or Generator Owner has evidence (electronic or hard copy) of SER data for circuit breaker position as specified in Requirement R2. Evidence may include, but is not limited to: (1) documents describing the device interconnections and configurations which may include a single design standard as representative for common installations; or (2) actual data recordings; or (3) station drawings.

**R3.** Each Transmission Owner and Generator Owner shall have FR data to determine the following electrical quantities for each triggered FR for the BES Elements it owns connected to the BES buses identified in Requirement R1: *[Violation Risk Factor: Lower] [Time Horizon: Long-term Planning]*

**3.1** Phase-to-neutral voltage for each phase of each specified BES bus.

**3.2** Each phase current and the residual or neutral current for the following BES Elements:

**3.2.1** Transformers that have a low-side operating voltage of 100kV or above.

**3.2.2** Transmission Lines.

**M3.** The Transmission Owner or Generator Owner has evidence (electronic or hard copy) of FR data that is sufficient to determine electrical quantities as specified in Requirement R3. Evidence may include, but is not limited to: (1) documents describing the device specifications and configurations which may include a single design standard as representative for common installations; or (2) actual data recordings or derivations; or (3) station drawings.

**R4.** Each Transmission Owner and Generator Owner shall have FR data as specified in Requirement R3 that meets the following: *[Violation Risk Factor: Lower] [Time Horizon: Long-term Planning]*

**4.1** A single record or multiple records that include:

- A pre-trigger record length of at least two cycles and a total record length of at least 30-cycles for the same trigger point, or
- At least two cycles of the pre-trigger data, the first three cycles of the post-trigger data, and the final cycle of the fault as seen by the fault recorder.

**4.2** A minimum recording rate of 16 samples per cycle.

**4.3** Trigger settings for at least the following:

**4.3.1** Neutral (residual) overcurrent.

**4.3.2** Phase undervoltage or overcurrent.



**M4.** The Transmission Owner or Generator Owner has evidence (electronic or hard copy) that FR data meets Requirement R4. Evidence may include, but is not limited to: (1) documents describing the device specification (R4, Part 4.2) and device configuration or settings (R4, Parts 4.1 and 4.3), or (2) actual data recordings or derivations.

**R5.** Each Reliability Coordinator~~Responsible Entity~~ shall: *[Violation Risk Factor: Lower]*  
*[Time Horizon: Long-term Planning]*

**5.1** Identify BES Elements for which dynamic Disturbance recording (DDR) data is required, including the following:

**5.1.1** Generating resource(s) with:

**5.1.1.1** Gross individual nameplate rating greater than or equal to 500 MVA.

**5.1.1.2** Gross individual nameplate rating greater than or equal to 300 MVA where the gross plant/facility aggregate nameplate rating is greater than or equal to 1,000 MVA.

**5.1.2** Any one BES Element that is part of a stability (angular or voltage) related System Operating Limit (SOL).

**5.1.3** Each terminal of a high voltage direct current (HVDC) circuit with a nameplate rating greater than or equal to 300 MVA, on the alternating current (AC) portion of the converter.

**5.1.4** One or more BES Elements that are part of an Interconnection Reliability Operating Limit (IROL).

**5.1.5** Any one BES Element within a major voltage sensitive area as defined by an area with an in-service undervoltage load shedding (UVLS) program.

**5.2** Identify a minimum DDR coverage, inclusive of those BES Elements identified in Part 5.1, of at least:

**5.2.1** One BES Element; and

**5.2.2** One BES Element per 3,000 MW of the Reliability Coordinator's~~Responsible Entity's~~ historical simultaneous peak System Demand.

**5.3** Notify all owners of identified BES Elements, within 90-calendar days of completion of Part 5.1, that their respective BES Elements require DDR data when requested.

**5.4** Re-evaluate all BES Elements at least once every five calendar years in accordance with Parts 5.1 and 5.2, and notify owners in accordance with Part 5.3 to implement the re-evaluated list of BES Elements as per the Implementation Plan.

- M5.** The ~~Reliability Coordinator~~~~Responsible Entity~~ has a dated (electronic or hard copy) list of BES Elements for which DDR data is required, developed in accordance with Requirement R5, Part 5.1 and Part 5.2; and re-evaluated in accordance with Part 5.4. The ~~Reliability Coordinator~~~~Responsible Entity~~ has dated evidence (electronic or hard copy) that each Transmission Owner or Generator Owner has been notified in accordance with Requirement 5, Part 5.3. Evidence may include, but is not limited to: letters, emails, electronic files, or hard copy records demonstrating transmittal of information.
- R6.** Each Transmission Owner shall have DDR data to determine the following electrical quantities for each BES Element it owns for which it received notification as identified in Requirement R5: *[Violation Risk Factor: Lower] [Time Horizon: Long-term Planning]*
- 6.1** One phase-to-neutral or positive sequence voltage.
  - 6.2** The phase current for the same phase at the same voltage corresponding to the voltage in Requirement R6, Part 6.1, or the positive sequence current.
  - 6.3** Real Power and Reactive Power flows expressed on a three phase basis corresponding to all circuits where current measurements are required.
  - 6.4** Frequency of any one of the voltage(s) in Requirement R6, Part 6.1.
- M6.** The Transmission Owner has evidence (electronic or hard copy) of DDR data to determine electrical quantities as specified in Requirement R6. Evidence may include, but is not limited to: (1) documents describing the device specifications and configurations, which may include a single design standard as representative for common installations; or (2) actual data recordings or derivations; or (3) station drawings.
- R7.** Each Generator Owner shall have DDR data to determine the following electrical quantities for each BES Element it owns for which it received notification as identified in Requirement R5: *[Violation Risk Factor: Lower] [Time Horizon: Long-term Planning]*
- 7.1** One phase-to-neutral, phase-to-phase, or positive sequence voltage at either the generator step-up transformer (GSU) high-side or low-side voltage level.
  - 7.2** The phase current for the same phase at the same voltage corresponding to the voltage in Requirement R7, Part 7.1, phase current(s) for any phase-to-phase voltages, or positive sequence current.
  - 7.3** Real Power and Reactive Power flows expressed on a three phase basis corresponding to all circuits where current measurements are required.
  - 7.4** Frequency of at least one of the voltages in Requirement R7, Part 7.1.
- M7.** The Generator Owner has evidence (electronic or hard copy) of DDR data to determine electrical quantities as specified in Requirement R7. Evidence may include, but is not limited to: (1) documents describing the device specifications and configurations, which may include a single design standard as representative for

common installations; or (2) actual data recordings or derivations; or (3) station drawings.

- R8.** Each Transmission Owner and Generator Owner responsible for DDR data for the BES Elements identified in Requirement R5 shall have continuous data recording and storage. If the equipment was installed prior to the effective date of this standard and is not capable of continuous recording, triggered records must meet the following: *[Violation Risk Factor: Lower] [Time Horizon: Long-term Planning]*

**8.1** Triggered record lengths of at least three minutes.

**8.2** At least one of the following three triggers:

- Off nominal frequency trigger set at:

	Low	High
○ Eastern Interconnection	<59.75 Hz	>61.0 Hz
○ Western Interconnection	<59.55 Hz	>61.0 Hz
○ ERCOT Interconnection	<59.35 Hz	>61.0 Hz
○ Hydro-Quebec Interconnection	<58.55 Hz	>61.5 Hz

- Rate of change of frequency trigger set at:

○ Eastern Interconnection	< -0.03125 Hz/sec	> 0.125 Hz/sec
○ Western Interconnection	< -0.05625 Hz/sec	> 0.125 Hz/sec
○ ERCOT Interconnection	< -0.08125 Hz/sec	> 0.125 Hz/sec
○ Hydro-Quebec Interconnection	< -0.18125 Hz/sec	> 0.1875 Hz/sec

- Undervoltage trigger set no lower than 85 percent of normal operating voltage for a duration of 5 seconds.

- M8.** Each Transmission Owner and Generator Owner has dated evidence (electronic or hard copy) of data recordings and storage in accordance with Requirement R8. Evidence may include, but is not limited to: (1) documents describing the device specifications and configurations, which may include a single design standard as representative for common installations; or (2) actual data recordings.

- R9.** Each Transmission Owner and Generator Owner responsible for DDR data for the BES Elements identified in Requirement R5 shall have DDR data that meet the following: *[Violation Risk Factor: Lower] [Time Horizon: Long-term Planning]*

**9.1** Input sampling rate of at least 960 samples per second.

**9.2** Output recording rate of electrical quantities of at least 30 times per second.

- M9.** The Transmission Owner or Generator Owner has evidence (electronic or hard copy) that DDR data meets Requirement R9. Evidence may include, but is not limited to: (1) documents describing the device specification, device configuration, or settings (R9, Part 9.1; R9, Part 9.2); or (2) actual data recordings (R9, Part 9.2).
- R10.** Each Transmission Owner and Generator Owner shall time synchronize all SER and FR data for the BES buses identified in Requirement R1 and DDR data for the BES Elements identified in Requirement R5 to meet the following: *[Violation Risk Factor: Lower] [Time Horizon: Long-term Planning]*
- 10.1** Synchronization to Coordinated Universal Time (UTC) with or without a local time offset.
- 10.2** Synchronized device clock accuracy within  $\pm 2$  milliseconds of UTC.
- M10.** The Transmission Owner or Generator Owner has evidence (electronic or hard copy) of time synchronization described in Requirement R10. Evidence may include, but is not limited to: (1) documents describing the device specification, configuration, or setting; (2) time synchronization indication or status; or (3) station drawings.
- R11.** Each Transmission Owner and Generator Owner shall provide, upon request, all SER and FR data for the BES buses identified in Requirement R1 and DDR data for the BES Elements identified in Requirement R5 to the Reliability Coordinator Responsible Entity, Regional Entity, or NERC in accordance with the following: *[Violation Risk Factor: Lower] [Time Horizon: Long-term Planning]*
- 11.1** Data will be retrievable for the period of 10-calendar days, inclusive of the day the data was recorded.
- 11.2** Data subject to Part 11.1 will be provided within 30-calendar days of a request unless an extension is granted by the requestor.
- 11.3** SER data will be provided in ASCII Comma Separated Value (CSV) format following Attachment 2.
- 11.4** FR and DDR data will be provided in electronic files that are formatted in conformance with C37.111, (IEEE Standard for Common Format for Transient Data Exchange (COMTRADE), revision C37.111-1999 or later.
- 11.5** Data files will be named in conformance with C37.232, IEEE Standard for Common Format for Naming Time Sequence Data Files (COMNAME), revision C37.232-2011 or later.
- M11.** The Transmission Owner or Generator Owner has evidence (electronic or hard copy) that data was submitted upon request in accordance with Requirement R11. Evidence may include, but is not limited to: (1) dated transmittals to the requesting

entity with formatted records; (2) documents describing data storage capability, device specification, configuration or settings; or (3) actual data recordings.

- R12.** Each Transmission Owner and Generator Owner shall, within 90-calendar days of the discovery of a failure of the recording capability for the SER, FR or DDR data, either: *[Violation Risk Factor: Lower] [Time Horizon: Long-term Planning]*
- Restore the recording capability, or
  - Submit a Corrective Action Plan (CAP) to the Regional Entity and implement it.

**M12.** The Transmission Owner or Generator Owner has dated evidence (electronic or hard copy) that meets Requirement R12. Evidence may include, but is not limited to: (1) dated reports of discovery of a failure, (2) documentation noting the date the data recording was restored, (3) SCADA records, or (4) dated CAP transmittals to the Regional Entity and evidence that it implemented the CAP.

## C. Compliance

### 1. Compliance Monitoring Process

#### 1.1. Compliance Enforcement Authority

As defined in the NERC Rules of Procedure, “Compliance Enforcement Authority” (CEA) means NERC or the Regional Entity in their respective roles of monitoring and enforcing compliance with the NERC Reliability Standards.

#### 1.2. Evidence Retention

The following evidence retention periods identify the period of time an entity is required to retain specific evidence to demonstrate compliance. For instances where the evidence retention period specified below is shorter than the time since the last audit, the Compliance Enforcement Authority may ask an entity to provide other evidence to show that it was compliant for the full time period since the last audit.

The Transmission Owner, Generator Owner, ~~Planning Coordinator~~, and Reliability Coordinator shall keep data or evidence to show compliance as identified below unless directed by its Compliance Enforcement Authority to retain specific evidence for a longer period of time as part of an investigation:

The Transmission Owner shall retain evidence of Requirement R1, Measure M1 for five calendar years.

The Transmission Owner shall retain evidence of Requirement R6, Measure M6 for three calendar years.

The Generator Owner shall retain evidence of Requirement R7, Measure M7 for three calendar years.

The Transmission Owner and Generator Owner shall retain evidence of requested data provided as per Requirements R2, R3, R4, R8, R9, R10, R11, and R12, Measures M2, M3, M4, M8, M9, M10, M11, and M12 for three calendar years.

The ~~Responsible Entity (Planning Coordinator or~~ Reliability Coordinator, ~~as applicable)~~ shall retain evidence of Requirement R5, Measure M5 for five calendar years.

If a Transmission Owner, Generator Owner, or Reliability Coordinator ~~Responsible Entity~~ is found non-compliant, it shall keep information related to the non-compliance until mitigation is completed and approved or for the time specified above, whichever is longer.

The Compliance Enforcement Authority shall keep the last audit records and all requested and submitted subsequent audit records.

**1.3. Compliance Monitoring and Assessment Processes:**

- Compliance Audit
- Self-Certification
- Spot Checking
- Compliance Violation Investigation
- Self-Reporting
- Complaints

**1.4. Additional Compliance Information**

None

### Table of Compliance Elements

R #	Time Horizon	VRF	Violation Severity Levels			
			Lower VSL	Moderate VSL	High VSL	Severe VSL
R1	Long-term Planning	Lower	<p>The Transmission Owner identified the BES buses as directed by Requirement R1, Part 1.1 or Part 1.3 for more than 80 percent but less than 100 percent of the required BES buses that they own.</p> <p>OR</p> <p>The Transmission Owner evaluated the BES buses as directed by Requirement R1, Part 1.1 or Part 1.3 but was late by 30-calendar days or less.</p> <p>OR</p> <p>The Transmission Owner as directed by Requirement R1, Part 1.2 was late in notifying the other</p>	<p>The Transmission Owner identified the BES buses as directed by Requirement R1, Part 1.1 or Part 1.3 for more than 70 percent but less than or equal to 80 percent of the required BES buses that they own.</p> <p>OR</p> <p>The Transmission Owner evaluated the BES buses as directed by Requirement R1, Part 1.1 or Part 1.3 but was late by greater than 30-calendar days and less than or equal to 60-calendar days.</p> <p>OR</p> <p>The Transmission Owner as directed by Requirement R1, Part</p>	<p>The Transmission Owner identified the BES buses as directed by Requirement R1, Part 1.1 or Part 1.3 for more than 60 percent but less than or equal to 70 percent of the required BES buses that they own.</p> <p>OR</p> <p>The Transmission Owner evaluated the BES buses as directed by Requirement R1, Part 1.1 or Part 1.3 but was late by greater than 60-calendar days and less than or equal to 90-calendar days.</p> <p>OR</p> <p>The Transmission Owner as directed by Requirement R1, Part</p>	<p>The Transmission Owner identified the BES buses as directed by Requirement R1, Part 1.1 or Part 1.3 for less than or equal to 60 percent of the required BES buses that they own.</p> <p>OR</p> <p>The Transmission Owner evaluated the BES buses as directed by Requirement R1, Part 1.1 or Part 1.3 but was late by greater than 90-calendar days.</p> <p>OR</p> <p>The Transmission Owner as directed by Requirement R1, Part 1.2 was late in notifying one or more other owners by</p>

			owners by 10-calendar days or less.	1.2 was late in notifying the other owners by greater than 10-calendar days but less than or equal to 20-calendar days.	1.2 was late in notifying the other owners by greater than 20-calendar days but less than or equal to 30-calendar days.	greater than 30-calendar days.
<b>R2</b>	Long-term Planning	Lower	Each Transmission Owner or Generator Owner as directed by Requirement R2 had more than 80 percent but less than 100 percent of the total SER data for circuit breaker position (open/close) for each of the circuit breakers at the BES buses identified in Requirement R1.	Each Transmission Owner or Generator Owner as directed by Requirement R2 had more than 70 percent but less than or equal to 80 percent of the total SER data for circuit breaker position (open/close) for each of the circuit breakers at the BES buses identified in Requirement R1.	Each Transmission Owner or Generator Owner as directed by Requirement R2 had more than 60 percent but less than or equal to 70 percent of the total SER data for circuit breaker position (open/close) for each of the circuit breakers at the BES buses identified in Requirement R1.	Each Transmission Owner or Generator Owner as directed by Requirement R2 for less than or equal to 60 percent of the total SER data for circuit breaker position (open/close) for each of the circuit breakers at the BES buses identified in Requirement R1.
<b>R3</b>	Long-term Planning	Lower	The Transmission Owner or Generator Owner had FR data as directed by Requirement R3, Parts 3.1 and 3.2 that covers more than 80 percent but less than 100 percent of the total set of required electrical	The Transmission Owner or Generator Owner had FR data as directed by Requirement R3, Parts 3.1 and 3.2 that covers more than 70 percent but less than or equal to 80 percent of the total set of required	The Transmission Owner or Generator Owner had FR data as directed by Requirement R3, Parts 3.1 and 3.2 that covers more than 60 percent but less than or equal to 70 percent of the total set of required	The Transmission Owner or Generator Owner had FR data as directed by Requirement R3, Parts 3.1 and 3.2 that covers less than or equal to 60 percent of the total set of required electrical quantities,



			quantities, which is the product of the total number of monitored BES Elements and the number of specified electrical quantities for each BES Element.	electrical quantities, which is the product of the total number of monitored BES Elements and the number of specified electrical quantities for each BES Element.	electrical quantities, which is the product of the total number of monitored BES Elements and the number of specified electrical quantities for each BES Element.	which is the product of the total number of monitored BES Elements and the number of specified electrical quantities for each BES Element.
<b>R4</b>	Long-term Planning	Lower	The Transmission Owner or Generator Owner had FR data that meets more than 80 percent but less than 100 percent of the total recording properties as specified in Requirement R4.	The Transmission Owner or Generator Owner had FR data that meets more than 70 percent but less than or equal to 80 percent of the total recording properties as specified in Requirement R4.	The Transmission Owner or Generator Owner had FR data that meets more than 60 percent but less than or equal to 70 percent of the total recording properties as specified in Requirement R4.	The Transmission Owner or Generator Owner had FR data that meets less than or equal to 60 percent of the total recording properties as specified in Requirement R4.
<b>R5</b>	Long-term Planning	Lower	The <u>Reliability Coordinator</u> <del>Responsible Entity</del> identified the BES Elements for which DDR data is required as directed by Requirement R5 for more than 80 percent but less than 100 percent of the	The <del>Responsible Entity</del> <u>Reliability Coordinator</u> identified the BES Elements for which DDR data is required as directed by Requirement R5 for more than 70 percent but less than or equal to 80 percent of the	The <u>Reliability Coordinator</u> <del>Responsible Entity</del> identified the BES Elements for which DDR data is required as directed by Requirement R5 for more than 60 percent but less than or equal to 70 percent of the	The <u>Reliability Coordinator</u> <del>Responsible Entity</del> identified the BES Elements for which DDR data is required as directed by Requirement R5 for less than or equal to 60 percent of the

			<p>required BES Elements included in Part 5.1.</p> <p>OR</p> <p>The <u>Responsible Entity Reliability Coordinator</u> identified the BES Elements for DDR as directed by Requirement R5, Part 5.1 or Part 5.4 but was late by 30-calendar days or less.</p> <p>OR</p> <p>The <u>Responsible Entity Reliability Coordinator</u> as directed by Requirement R5, Part 5.3 was late in notifying the owners by 10-calendar days or less.</p>	<p>required BES Elements included in Part 5.1.</p> <p>OR</p> <p>The <u>Responsible Entity Reliability Coordinator</u> identified the BES Elements for DDR as directed by Requirement R5, Part 5.1 or Part 5.4 but was late by greater than 30-calendar days and less than or equal to 60 -calendar days.</p> <p>OR</p> <p>The <u>Responsible Entity Reliability Coordinator</u> as directed by Requirement R5, Part 5.3 was late in notifying the owners by greater than 10-calendar days but less than or equal to 20-calendar days.</p>	<p>required BES Elements included in Part 5.1.</p> <p>OR</p> <p>The <u>Responsible Entity Reliability Coordinator</u> identified the BES Elements for DDR as directed by Requirement R5, Part 5.1 or Part 5.4 but was late by greater than 60-calendar days and less than or equal to 90-calendar days.</p> <p>OR</p> <p>The <u>Responsible Entity Reliability Coordinator</u> as directed by Requirement R5, Part 5.3 was late in notifying the owners by greater than 20-calendar days but less than or equal to 30-calendar days.</p>	<p>required BES Elements included in Part 5.1.</p> <p>OR</p> <p>The <u>Responsible Entity Reliability Coordinator</u> identified the BES Elements for DDR as directed by Requirement R5, Part 5.1 or Part 5.4 but was late by greater than 90-calendar days.</p> <p>OR</p> <p>The <u>Responsible Entity Reliability Coordinator</u> as directed by Requirement R5, Part 5.3 was late in notifying one or more owners by greater than 30-calendar days.</p> <p>OR</p> <p>The <u>Responsible Entity Reliability Coordinator</u> failed to ensure a minimum DDR coverage per Part 5.2.</p>
--	--	--	--	---	--	---

<b>R6</b>	Long-term Planning	Lower	The Transmission Owner had DDR data as directed by Requirement R6, Parts 6.1 through 6.4 that covered more than 80 percent but less than 100 percent of the total required electrical quantities for all applicable BES Elements.	The Transmission Owner had DDR data as directed by Requirement R6, Parts 6.1 through 6.4 for more than 70 percent but less than or equal to 80 percent of the total required electrical quantities for all applicable BES Elements.	The Transmission Owner had DDR data as directed by Requirement R6, Parts 6.1 through 6.4 for more than 60 percent but less than or equal to 70 percent of the total required electrical quantities for all applicable BES Elements.	The Transmission Owner failed to have DDR data as directed by Requirement R6, Parts 6.1 through 6.4.
<b>R7</b>	Long-term Planning	Lower	The Generator Owner had DDR data as directed by Requirement R7, Parts 7.1 through 7.4 that covers more than 80 percent but less than 100 percent of the total required electrical quantities for all applicable BES Elements.	The Generator Owner had DDR data as directed by Requirement R7, Parts 7.1 through 7.4 for more than 70 percent but less than or equal to 80 percent of the total required electrical quantities for all applicable BES Elements.	The Generator Owner had DDR data as directed by Requirement R7, Parts 7.1 through 7.4 for more than 60 percent but less than or equal to 70 percent of the total required electrical quantities for all applicable BES Elements.	The Generator Owner failed to have DDR data as directed by Requirement R7, Parts 7.1 through 7.4.
<b>R8</b>	Long-term Planning	Lower	The Transmission Owner or Generator Owner had continuous or non-continuous DDR data, as directed	The Transmission Owner or Generator Owner had continuous or non-continuous DDR data, as directed	The Transmission Owner or Generator Owner had continuous or non-continuous DDR data, as directed	The Transmission Owner or Generator Owner failed to have continuous or non-continuous DDR data,

			in Requirement R8, for more than 80 percent but less than 100 percent of the BES Elements they own as determined in Requirement R5.	in Requirement R8, for more than 70 percent but less than or equal to 80 percent of the BES Elements they own as determined in Requirement R5.	in Requirement R8, for more than 60 percent but less than or equal to 70 percent of the BES Elements they own as determined in Requirement R5.	as directed in Requirement R8, for the BES Elements they own as determined in Requirement R5.
<b>R9</b>	Long-term Planning	Lower	The Transmission Owner or Generator Owner had DDR data that meets more than 80 percent but less than 100 percent of the total recording properties as specified in Requirement R9.	The Transmission Owner or Generator Owner had DDR data that meets more than 70 percent but less than or equal to 80 percent of the total recording properties as specified in Requirement R9.	The Transmission Owner or Generator Owner had DDR data that meets more than 60 percent but less than or equal to 70 percent of the total recording properties as specified in Requirement R9.	The Transmission Owner or Generator Owner had DDR data that meets less than or equal to 60 percent of the total recording properties as specified in Requirement R9.

<b>R10</b>	Long-term Planning	Lower	The Transmission Owner or Generator Owner had time synchronization per Requirement R10, Parts 10.1 and 10.2 for SER, FR, and DDR data for more than 90 percent but less than 100 percent of the BES buses identified in Requirement R1 and BES Elements identified in Requirement R5 as directed by Requirement R10.	The Transmission Owner or Generator Owner had time synchronization per Requirement R10, Parts 10.1 and 10.2 for SER, FR, and DDR data for more than 80 percent but less than or equal to 90 percent of the BES buses identified in Requirement R1 and BES Elements identified in Requirement R5 as directed by Requirement R10.	The Transmission Owner or Generator Owner had time synchronization per Requirement R10, Parts 10.1 and 10.2 for SER, FR, and DDR data for more than 70 percent but less than or equal to 80 percent of the BES buses identified in Requirement R1 and BES Elements identified in Requirement R5 as directed by Requirement R10.	The Transmission Owner or Generator Owner failed to have time synchronization per Requirement R10, Parts 10.1 and 10.2 for SER, FR, and DDR data for less than or equal to 70 percent of the BES buses identified in Requirement R1 and BES Elements identified in Requirement R5 as directed by Requirement R10.
<b>R11</b>	Long-term Planning	Lower	The Transmission Owner or Generator Owner as directed by Requirement R11, Part 11.1 provided the requested data more than 30-calendar days but less than 40-calendar days after the request unless an extension was granted	The Transmission Owner or Generator Owner as directed by Requirement R11, Part 11.1 provided the requested data more than 40-calendar days but less than or equal to 50-calendar days after the request unless an extension	The Transmission Owner or Generator Owner as directed by Requirement R11, Part 11.1 provided the requested data more than 50-calendar days but less than or equal to 60-calendar days after the request unless an extension	The Transmission Owner or Generator Owner as directed by Requirement R11, Part 11.1 failed to provide the requested data more than 60-calendar days after the request unless an extension was granted by the requesting authority.

			<p>by the requesting authority.</p> <p>OR</p> <p>The Transmission Owner or Generator Owner as directed by Requirement R11 provided more than 90 percent but less than 100 percent of the requested data.</p> <p>OR</p> <p>The Transmission Owner or Generator Owner as directed by Requirement R11, Parts 11.3 through 11.5 provided more than 90 percent of the data but less than 100 percent of the data in the proper data format.</p>	<p>was granted by the requesting authority.</p> <p>OR</p> <p>The Transmission Owner or Generator Owner as directed by Requirement R11 provided more than 80 percent but less than or equal to 90 percent of the requested data.</p> <p>OR</p> <p>The Transmission Owner or Generator Owner as directed by Requirement R11, Parts 11.3 through 11.5 provided more than 80 percent of the data but less than or equal to 90 percent of the data in the proper data format.</p>	<p>was granted by the requesting authority.</p> <p>OR</p> <p>The Transmission Owner or Generator Owner as directed by Requirement R11 provided more than 70 percent but less than or equal to 80 percent of the requested data.</p> <p>OR</p> <p>The Transmission Owner or Generator Owner as directed by Requirement R11, Parts 11.3 through 11.5 provided more than 70 percent of the data but less than or equal to 80 percent of the data in the proper data format.</p>	<p>OR</p> <p>The Transmission Owner or Generator Owner as directed by Requirement R11 failed to provide less than or equal to 70 percent of the requested data.</p> <p>OR</p> <p>The Transmission Owner or Generator Owner as directed by Requirement R11, Parts 11.3 through 11.5 provided less than or equal to 70 percent of the data in the proper data format.</p>
<b>R12</b>	Long-term Planning	Lower	The Transmission Owner or Generator Owner as directed by Requirement R12	The Transmission Owner or Generator Owner as directed by Requirement R12	The Transmission Owner or Generator Owner as directed by Requirement R12	The Transmission Owner or Generator Owner as directed by Requirement R12

			<p>reported a failure and provided a Corrective Action Plan to the Regional Entity more than 90-calendar days but less than or equal to 100-calendar days after discovery of the failure.</p>	<p>reported a failure and provided a Corrective Action Plan to the Regional Entity more than 100-calendar days but less than or equal to 110-calendar days after discovery of the failure.</p>	<p>reported a failure and provided a Corrective Action Plan to the Regional Entity more than 110-calendar days but less than or equal to 120-calendar days after discovery of the failure.</p> <p>OR</p> <p>The Transmission Owner or Generator Owner as directed by Requirement R12 submitted a CAP to the Regional Entity but failed to implement it.</p>	<p>failed to report a failure and provide a Corrective Action Plan to the Regional Entity more than 120-calendar days after discovery of the failure.</p> <p>OR</p> <p>Transmission Owner or Generator Owner as directed by Requirement R12 failed to restore the recording capability and failed to submit a CAP to the Regional Entity.</p>
--	--	--	---	--	---	---

## D. Regional Variances

None.

## E. Interpretations

None.

## F. Associated Documents

None.

## G. References

IEEE C37.111: Common format for transient data exchange (COMTRADE) for power Systems.

IEEE C37.232-2011, IEEE Standard for Common Format for Naming Time Sequence Data Files (COMNAME). Standard published 11/09/2011 by IEEE.

NPCC SP6 Report Synchronized Event Data Reporting, revised March 31, 2005

U.S.-Canada Power System Outage Task Force, Final Report on the August 14, 2003 Blackout in the United States and Canada: Causes and Recommendations (2004).

U.S.-Canada Power System Outage Task Force Interim Report: Causes of the August 14th Blackout in the United States and Canada (Nov. 2003)

## Version History

Version	Date	Action	Change Tracking
0	February 8, 2005	Adopted by NERC Board of Trustees	New
1	August 2, 2006	Adopted by NERC Board of Trustees	Revised
2	November 13, 2014	Adopted by NERC Board of Trustees	Revised under Project 2007-11 and merged with PRC-018-1.
2	September 24, 2015	FERC approved PRC-005-4. Docket No. RM15-4-000; Order No. 814	
3	May 13, 2021	Adopted by NERC Board of Trustees	Revised under Project 2015-09



## Attachment 1

### Methodology for Selecting Buses for Capturing Sequence of Events Recording (SER) and Fault Recording (FR) Data

#### (Requirement R1)

To identify monitored BES buses for sequence of events recording (SER) and Fault recording (FR) data required by Requirement 1, each Transmission Owner shall follow sequentially, unless otherwise noted, the steps listed below:

Step 1. Determine a complete list of BES buses that it owns.

For the purposes of this standard, a single BES bus includes physical buses with breakers connected at the same voltage level within the same physical location sharing a common ground grid. These buses may be modeled or represented by a single node in fault studies. For example, ring bus or breaker-and-a-half bus configurations are considered to be a single bus.

Step 2. Reduce the list to those BES buses that have a maximum available calculated three phase short circuit MVA of 1,500 MVA or greater. If there are no buses on the resulting list, proceed to Step 7.

Step 3. Determine the 11 BES buses on the list with the highest maximum available calculated three phase short circuit MVA level. If the list has 11 or fewer buses, proceed to Step 7.

Step 4. Calculate the median MVA level of the 11 BES buses determined in Step 3.

Step 5. Multiply the median MVA level determined in Step 4 by 20 percent.

Step 6. Reduce the BES buses on the list to only those that have a maximum available calculated three phase short circuit MVA higher than the greater of:

- 1,500 MVA or
- 20 percent of median MVA level determined in Step 5.

Step 7. If there are no BES buses on the list: the procedure is complete and no FR and SER data will be required. Proceed to Step 9.

If the list has 1 or more but less than or equal to 11 BES buses: FR and SER data is required at the BES bus with the highest maximum available calculated three phase short circuit MVA as determined in Step 3. Proceed to Step 9.

If the list has more than 11 BES buses: SER and FR data is required on at least the 10 percent of the BES buses determined in Step 6 with the highest maximum available calculated three phase short circuit MVA. Proceed to Step 8.

Step 8. SER and FR data is required at additional BES buses on the list determined in Step 6. The aggregate of the number of BES buses determined in Step 7 and this Step will be at least 20 percent of the BES buses determined in Step 6.

The additional BES buses are selected, at the Transmission Owner's discretion, to provide maximum wide-area coverage for SER and FR data. The following BES bus locations are recommended:

- Electrically distant buses or electrically distant from other DME devices.
- Voltage sensitive areas.
- Cohesive load and generation zones.
- BES buses with a relatively high number of incident Transmission circuits.
- BES buses with reactive power devices.
- Major Facilities interconnecting outside the Transmission Owner's area.

Step 9. The list of monitored BES buses for SER and FR data for Requirement R1 is the aggregate of the BES buses determined in Steps 7 and 8.

**Attachment 2**  
**Sequence of Events Recording (SER) Data Format**  
**(Requirement R11, Part 11.3)**

Date, Time, Local Time Code, Substation, Device, State<sup>1</sup>

08/27/13, 23:58:57.110, -5, Sub 1, Breaker 1, Close

08/27/13, 23:58:57.082, -5, Sub 2, Breaker 2, Close

08/27/13, 23:58:47.217, -5, Sub 1, Breaker 1, Open

08/27/13, 23:58:47.214, -5, Sub 2, Breaker 2, Open

---

<sup>1</sup> "OPEN" and "CLOSE" are used as examples. Other terminology such as TRIP, TRIP TO LOCKOUT, RECLOSE, etc. is also acceptable.

### High Level Requirement Overview

Requirement	Entity	Identify BES Buses	Notification	SER	FR	5 Year Re-evaluation
R1	TO	X	X	X	X	X
R2	TO   GO			X		
R3	TO   GO				X	
R4	TO   GO				X	
Requirement	Entity	Identify BES Elements	Notification	DDR	5 Year Re-evaluation	
R5	<del>RE (PC   RC)</del>	X	X	X	X	
R6	TO			X		
R7	GO			X		
R8	TO   GO			X		
R9	TO   GO			X		
Requirement	Entity	Time Synchronization	Provide SER, FR, DDR Data		SER, FR, DDR Availability	
R10	TO   GO	X				
R11	TO   GO		X			
R12	TO   GO				X	

### **Rationale:**

During development of this standard, text boxes were embedded within the standard to explain the rationale for various parts of the standard. Upon BOT approval, the text from the rationale text boxes was moved to this section.

### **Rationale for Functional Entities:**

~~When the term “Responsible Entity” is used in PRC-002-2, it specifically refers to those entities listed under 4.1. The Responsible Entity—the Planning Coordinator or~~ Because the Reliability Coordinator, ~~as applicable in each Interconnection—~~ has the best wide-area view of the BES, the Reliability Coordinator ~~and~~ is most suited to be responsible for determining the BES Elements for which dynamic Disturbance recording (DDR) data is required. The Transmission Owners and Generator Owners will have the responsibility for ensuring that adequate data is available for those BES Elements selected.

BES buses where sequence of events recording (SER) and fault recording (FR) data is required are best selected by Transmission Owners because they have the required tools, information, and working knowledge of their Systems to determine those buses. The Transmission Owners and Generator Owners that own BES Elements on those BES buses will have the responsibility for ensuring that adequate data is available.

### **Rationale for R1:**

Analysis and reconstruction of BES events requires SER and FR data from key BES buses. Attachment 1 provides a uniform methodology to identify those BES buses. Repeated testing of the Attachment 1 methodology has demonstrated the proper distribution of SER and FR data collection. Review of actual BES short circuit data received from the industry in response to the DMSDT’s data request (June 5, 2013 through July 5, 2013) illuminated a strong correlation between the available short circuit MVA at a Transmission bus and its relative size and importance to the BES based on (i) its voltage level, (ii) the number of Transmission Lines and other BES Elements connected to the BES bus, and (iii) the number and size of generating units connected to the bus. BES buses with a large short circuit MVA level are BES Elements that have a significant effect on System reliability and performance. Conversely, BES buses with very low short circuit MVA levels seldom cause wide-area or cascading System events, so SER and FR data from those BES Elements are not as significant. After analyzing and reviewing the collected data submittals from across the continent, the threshold MVA values were chosen to provide sufficient data for event analysis using engineering and operational judgment.

Concerns have existed that the defined methodology for bus selection will overly concentrate data to selected BES buses. For the purpose of PRC-002-~~23~~, there are a minimum number of BES buses for which SER and FR data is required based on the short circuit level. With these concepts and the objective being sufficient recording coverage for event analysis, the DMSDT developed the procedure in Attachment 1 that utilizes the maximum available calculated three phase short circuit MVA. This methodology ensures comparable and sufficient coverage for SER and FR data regardless of variations in the size and System topology of Transmission Owners

across all Interconnections. Additionally, this methodology provides a degree of flexibility for the use of judgment in the selection process to ensure sufficient distribution.

BES buses where SER and FR data is required are best selected by Transmission Owners because they have the required tools, information, and working knowledge of their Systems to determine those buses.

Each Transmission Owner must re-evaluate the list of BES buses at least every five calendar years to address System changes since the previous evaluation. Changes to the BES do not mandate immediate inclusion of BES buses into the currently enforced list, but the list of BES buses will be re-evaluated at least every five calendar years to address System changes since the previous evaluation.

Since there may be multiple owners of equipment that comprise a BES bus, the notification required in R1 is necessary to ensure all owners are notified.

A 90-calendar day notification deadline provides adequate time for the Transmission Owner to make the appropriate determination and notification.

**Rationale for R2:**

The intent is to capture SER data for the status (open/close) of the circuit breakers that can interrupt the current flow through each BES Element connected to a BES bus. Change of state of circuit breaker position, time stamped according to Requirement R10 to a time synchronized clock, provides the basis for assembling the detailed sequence of events timeline of a power System Disturbance. Other status monitoring nomenclature can be used for devices other than circuit breakers.

**Rationale for R3:**

The required electrical quantities may either be directly measured or determinable if sufficient FR data is captured (e.g. residual or neutral current if the phase currents are directly measured). In order to cover all possible fault types, all BES bus phase-to-neutral voltages are required to be determinable for each BES bus identified in Requirement R1. BES bus voltage data is adequate for System Disturbance analysis. Phase current and residual current are required to distinguish between phase faults and ground faults. It also facilitates determination of the fault location and cause of relay operation. For transformers (Part 3.2.1), the data may be from either the high-side or the low-side of the transformer. Generator step-up transformers (GSUs) and leads that connect the GSU transformer(s) to the Transmission System that are used exclusively to export energy directly from a BES generating unit or generating plant are excluded from Requirement R3 because the fault current contribution from a generator to a fault on the Transmission System will be captured by FR data on the Transmission System, and Transmission System FR will capture faults on the generator interconnection.

Generator Owners may install this capability or, where the Transmission Owners already have suitable FR data, contract with the Transmission Owner. However, when required, the Generator Owner is still responsible for the provision of this data.

**Rationale for R4:**

Time stamped pre- and post-trigger fault data aid in the analysis of power System operations and determination if operations were as intended. System faults generally persist for a short time period, thus a 30-cycle total minimum record length is adequate. Multiple records allow for legacy microprocessor relays which, when time-synchronized, are capable of providing adequate fault data but not capable of providing fault data in a single record with 30-contiguous cycles total.

A minimum recording rate of 16 samples per cycle (960 Hz) is required to get sufficient point on wave data for recreating accurate fault conditions.

**Rationale for R5:**

DDR is used for capturing the BES transient and post-transient response following Disturbances, and the data is used for event analysis and validating System performance. DDR plays a critical role in wide-area Disturbance analysis, and Requirement R5 ensures there is adequate wide-area coverage of DDR data for specific BES Elements to facilitate accurate and efficient event analysis. The ~~Reliability Coordinator~~Responsible Entity has the best wide-area view of the System and needs to ensure that there are sufficient BES Elements identified for DDR data capture. The identification of BES Elements requiring DDR data as per Requirement R5 is based upon industry experience with wide-area Disturbance analysis and the need for adequate data to facilitate event analysis. Ensuring data is captured for these BES Elements will significantly improve the accuracy of analysis and understanding of why an event occurred, not simply what occurred.

From its experience with changes to the Bulk Electric System that would affect DDR, the DMSDT decided that the five calendar year re-evaluation of the list is a reasonable interval for this review. Changes to the BES do not mandate immediate inclusion of BES Elements into the in force list, but the list of BES Elements will be re-evaluated at least every five calendar years to address System changes since the previous evaluation. However, this standard does not preclude the ~~Responsible Entity~~Reliability Coordinator from performing this re-evaluation more frequently to capture updated BES Elements.

~~The Responsible Entity, for the purposes of this standard, is defined as the PC or RC depending upon Interconnection, because they have the best overall perspective for determining wide-area DDR coverage. The Planning Coordinator and Reliability Coordinator assume different functions across the continent; therefore the Responsible Entity is defined in the Applicability Section and used throughout this standard.~~

The ~~Responsible Entity~~Reliability Coordinator must notify all owners of the selected BES Elements that DDR data is required for this standard. The ~~Responsible Entity~~Reliability Coordinator is only required to share the list of selected BES Elements that each Transmission Owner and Generator Owner respectively owns, not the entire list. This communication of

selected BES Elements is required to ensure that the owners of the respective BES Elements are aware of their responsibilities under this standard.

Implementation of the monitoring equipment is the responsibility of the respective Transmission Owners and Generator Owners, the timeline for installing this capability is outlined in the Implementation Plan, and starts from notification of the list from the ~~Responsible Entity~~Reliability Coordinator. Data for each BES Element as defined by the ~~Responsible Entity~~Reliability Coordinator must be provided; however, this data can be either directly measured or accurately calculated. With the exception of HVDC circuits, DDR data is only required for one end or terminal of the BES Elements selected. For example, DDR data must be provided for at least one terminal of a Transmission Line or generator step-up (GSU) transformer, but not both terminals. For an interconnection between two ~~Responsible Entities~~Reliability Coordinators, each ~~Responsible Entity~~Reliability Coordinator will consider this interconnection independently, and are expected to work cooperatively to determine how to monitor the BES Elements that require DDR data. For an interconnection between two TO's, or a TO and a GO, the ~~Responsible Entity~~Reliability Coordinator will determine which entity will provide the data. The ~~Responsible Entity~~Reliability Coordinator will notify the owners that their BES Elements require DDR data.

Refer to the Guidelines and Technical Basis Section for more detail on the rationale and technical reasoning for each identified BES Element in Requirement R5, Part 5.1; monitoring these BES Elements with DDR will facilitate thorough and informative event analysis of wide-area Disturbances on the BES. Part 5.2 is included to ensure wide-area coverage across all ~~Responsible Entities~~Reliability Coordinators. It is intended that each ~~Responsible Entity~~Reliability Coordinator will have DDR data for one BES Element and at least one additional BES Element per 3,000 MW of its historical simultaneous peak System Demand.

**Rationale for R6:**

DDR is used to measure transient response to System Disturbances during a relatively balanced post-fault condition. Therefore, it is sufficient to provide a phase-to-neutral voltage or positive sequence voltage. The electrical quantities can be determined (calculated, derived, etc.).

Because all of the BES buses within a location are at the same frequency, one frequency measurement is adequate.

The data requirements for PRC-002-~~23~~ are based on a System configuration assuming all normally closed circuit breakers on a BES bus are closed.

**Rationale for R7:**

A crucial part of wide-area Disturbance analysis is understanding the dynamic response of generating resources. Therefore, it is necessary for Generator Owners to have DDR at either the high- or low-side of the generator step-up transformer (GSU) measuring the specified electrical quantities to adequately capture generator response. This standard defines the 'what' of DDR, not the 'how'. Generator Owners may install this capability or, where the Transmission Owners already have suitable DDR data, contract with the Transmission Owner. However, the Generator Owner is still responsible for the provision of this data.



**Rationale for R8:**

Large scale System outages generally are an evolving sequence of events that occur over an extended period of time, making DDR data essential for event analysis. Data available pre- and post-contingency helps identify the causes and effects of each event leading to outages. Therefore, continuous recording and storage are necessary to ensure sufficient data is available for the entire event.

Existing DDR data recording across the BES may not record continuously. To accommodate its use for the purposes of this standard, triggered records are acceptable if the equipment was installed prior to the effective date of this standard. The frequency triggers are defined based on the dynamic response associated with each Interconnection. The undervoltage trigger is defined to capture possible delayed undervoltage conditions such as Fault Induced Delayed Voltage Recovery (FIDVR).

**Rationale for R9:**

An input sampling rate of at least 960 samples per second, which corresponds to 16 samples per cycle on the input side of the DDR equipment, ensures adequate accuracy for calculation of recorded measurements such as complex voltage and frequency.

An output recording rate of electrical quantities of at least 30 times per second refers to the recording and measurement calculation rate of the device. Recorded measurements of at least 30 times per second provide adequate recording speed to monitor the low frequency oscillations typically of interest during power System Disturbances.

**Rationale for R10:**

Time synchronization of Disturbance monitoring data is essential for time alignment of large volumes of geographically dispersed records from diverse recording sources. Coordinated Universal Time (UTC) is a recognized time standard that utilizes atomic clocks for generating precision time measurements. All data must be provided in UTC formatted time either with or without the local time offset, expressed as a negative number (the difference between UTC and the local time zone where the measurements are recorded).

Accuracy of time synchronization applies only to the clock used for synchronizing the monitoring equipment. The equipment used to measure the electrical quantities must be time synchronized to  $\pm 2$  ms accuracy; however, accuracy of the application of this time stamp and therefore the accuracy of the data itself is not mandated. This is because of inherent delays associated with measuring the electrical quantities and events such as breaker closing, measurement transport delays, algorithm and measurement calculation techniques, etc. Ensuring that the monitoring devices internal clocks are within  $\pm 2$  ms accuracy will suffice with respect to providing time synchronized data.

**Rationale for R11:**

Wide-area Disturbance analysis includes data recording from many devices and entities. Standardized formatting and naming conventions of these files significantly improves timely analysis.

Providing the data within 30-calendar days (or the granted extension time), subject to Part 11.1, allows for reasonable time to collect the data and perform any necessary computations or formatting.

Data is required to be retrievable for 10-calendar days inclusive of the day the data was recorded, i.e. a -10-calendar day rolling window of available data. Data hold requests are usually initiated the same or next day following a major event for which data is requested. A 10-calendar day time frame provides a practical limit on the duration of data required to be stored and informs the requesting entities as to how long the data will be available. The requestor of data has to be aware of the Part 11.1 10-calendar day retrievability because requiring data retention for a longer period of time is expensive and unnecessary.

SER data shall be provided in a simple ASCII .CSV format as outlined in Attachment 2. Either equipment can provide the data or a simple conversion program can be used to convert files into this format. This will significantly improve the data format for event records, enabling the use of software tools for analyzing the SER data.

Part 11.4 specifies FR and DDR data files be provided in conformance with IEEE C37.111, IEEE Standard for Common Format for Transient Exchange (COMTRADE), revision 1999 or later. The use of IEEE C37.111-1999 or later is well established in the industry. C37.111-2013 is a version of COMTRADE that includes an annex describing the application of the COMTRADE standard to synchrophasor data; however, version C37.111-1999 is commonly used in the industry today.

Part 11.5 uses a standardized naming format, C37.232-2011, IEEE Standard for Common Format for Naming Time Sequence Data Files (COMNAME), for providing Disturbance monitoring data. This file format allows a streamlined analysis of large Disturbances, and includes critical records such as local time offset associated with the synchronization of the data.

**Rationale for R12:**

Each Transmission Owner and Generator Owner who owns equipment used for collecting the data required for this standard must repair any failures within 90-calendar days to ensure that adequate data is available for event analysis. If the Disturbance monitoring capability cannot be restored within 90-calendar days (e.g. budget cycle, service crews, vendors, needed outages, etc.), the entity must develop a Corrective Action Plan (CAP) for restoring the data recording capability. The timeline required for the CAP depends on the entity and the type of data required. It is treated as a failure if the recording capability is out of service for maintenance and/or testing for greater than 90-calendar days. An outage of the monitored BES Element does not constitute a failure of the Disturbance monitoring capability.

## Guidelines and Technical Basis Section

### Introduction

The emphasis of PRC-002-~~23~~ is not on how Disturbance monitoring data is captured, but what Bulk Electric System data is captured. There are a variety of ways to capture the data PRC-002-~~23~~ addresses, and existing and currently available equipment can meet the requirements of this standard. PRC-002-~~23~~ also addresses the importance of addressing the availability of Disturbance monitoring capability to ensure the completeness of BES data capture.

The data requirements for PRC-002-~~23~~ are based on a System configuration assuming all normally closed circuit breakers on a bus are closed.

PRC-002-~~23~~ addresses “what” data is recorded, not “how” it is recorded.

### Guideline for Requirement R1:

Sequence of events and fault recording for the analysis, reconstruction, and reporting of System Disturbances is important. However, SER and FR data is not required at every BES bus on the BES to conduct adequate or thorough analysis of a Disturbance. As major tools of event analysis, the time synchronized time stamp for a breaker change of state and the recorded waveforms of voltage and current for individual circuits allows the precise reconstruction of events of both localized and wide-area Disturbances.

More quality information is always better than less when performing event analysis. However, 100 percent coverage of all BES Elements is not practical nor required for effective analysis of wide-area Disturbances. Therefore, selectivity of required BES buses to monitor is important for the following reasons:

1. Identify key BES buses with breakers where crucial information is available when required.
2. Avoid excessive overlap of coverage.
3. Avoid gaps in critical coverage.
4. Provide coverage of BES Elements that could propagate a Disturbance.
5. Avoid mandates to cover BES Elements that are more likely to be a casualty of a Disturbance rather than a cause.
6. Establish selection criteria to provide effective coverage in different regions of the continent.

The major characteristics available to determine the selection process are:

1. System voltage level;
2. The number of Transmission Lines into a substation or switchyard;
3. The number and size of connected generating units;
4. The available short circuit levels.

Although it is straightforward to establish criteria for the application of identified BES buses, analysis was required to establish a sound technical basis to fulfill the required objectives.

To answer these questions and establish criteria for BES buses of SER and FR, the DMSDT established a sub-team referred to as the Monitored Value Analysis Team (MVA Team). The MVA Team collected information from a wide variety of Transmission Systems throughout the continent to analyze Transmission buses by the characteristics previously identified for the selection process.

The MVA Team learned that the development of criteria is not possible for adequate SER and FR coverage, based solely upon simple, bright line characteristics, such as the number of lines into a substation or switchyard at a particular voltage level or at a set level of short circuit current. To provide the appropriate coverage, a relatively simple but effective Methodology for Selecting Buses for Capturing Sequence of Events Recording (SER) and Fault Recording (FR) Data was developed. This Procedure, included as Attachment 1, assists entities in fulfilling Requirement R1 of the standard.

The Methodology for Selecting Buses for Capturing Sequence of Events Recording (SER) and Fault Recording (FR) Data is weighted to buses with higher short circuit levels. This is chosen for the following reasons:

1. The method is voltage level independent.
2. It is likely to select buses near large generation centers.
3. It is likely to select buses where delayed clearing can cause Cascading.
4. Selected buses directly correlate to the Universal Power Transfer equation: Lower Impedance – increased power flows – greater System impact.

To perform the calculations of Attachment 1, the following information below is required and the following steps (provided in summary form) are required for Systems with more than 11 BES buses with three phase short circuit levels above 1,500 MVA.

1. Total number of BES buses in the Transmission System under evaluation.
  - a. Only tangible substation or switchyard buses are included.
  - b. Pseudo buses created for analysis purposes in System models are excluded.
2. Determine the three phase short circuit MVA for each BES bus.
3. Exclude BES buses from the list with short circuit levels below 1,500 MVA.
4. Determine the median short circuit for the top 11 BES buses on the list (position number 6).
5. Multiply median short circuit level by 20 percent.
6. Reduce the list of BES buses to those with short circuit levels higher than 20 percent of the median.
7. Apply SER and FR at BES buses with short circuit levels in the top 10 percent of the list (from 6).

8. Apply SER and FR at BES buses at an additional 10 percent of the list using engineering judgment, and allowing flexibility to factor in the following considerations:
  - Electrically distant BES buses or electrically distant from other DME devices
  - Voltage sensitive areas
  - Cohesive load and generation zones
  - BES buses with a relatively high number of incident Transmission circuits
  - BES buses with reactive power devices
  - Major facilities interconnecting outside the Transmission Owner's area.

For event analysis purposes, more valuable information is attained about generators and their response to System events pre- and post-contingency through DDR data versus SER or FR records. SER data of the opening of the primary generator output interrupting devices (e.g. synchronizing breaker) may not reliably indicate the actual time that a generator tripped; for instance, when it trips on reverse power after loss of its prime mover (e.g. combustion or steam turbine). As a result, this standard only requires DDR data.

The re-evaluation interval of five years was chosen based on the experience of the DMSDT to address changing System configurations while creating balance in the frequency of re-evaluations.

**Guideline for Requirement R2:**

Analyses of wide-area Disturbances often begin by evaluation of SERs to help determine the initiating event(s) and follow the Disturbance propagation. Recording of breaker operations help determine the interruption of line flows while generator loading is best determined by DDR data, since generator loading can be essentially zero regardless of breaker position. However, generator breakers directly connected to an identified BES bus are required to have SER data captured. It is important in event analysis to know when a BES bus is cleared regardless of a generator's loading.

Generator Owners are included in this requirement because a Generator Owner may, in some instances, own breakers directly connected to the Transmission Owner's BES bus.

**Guideline for Requirement R3:**

The BES buses for which FR data is required are determined based on the methodology described in Attachment 1 of the standard. The BES Elements connected to those BES buses for which FR data is required include:

- Transformers with a low-side operating voltage of 100kV or above
- Transmission Lines

Only those BES Elements that are identified as BES as defined in the latest in effect NERC definition are to be monitored. For example, radial lines or transformers with low-side voltage less than 100kV are not included.

FR data must be determinable from each terminal of a BES Element connected to applicable BES buses.

Generator step-up transformers (GSU) are excluded from the above based on the following:

- Current contribution from a generator in case of fault on the Transmission System will be captured by FR data on the Transmission System.
- For faults on the interconnection to generating facilities it is sufficient to have fault current data from the Transmission station end of the interconnection. Current contribution from a generator can be readily calculated if needed.

The DMSDT, after consulting with NERC's Event Analysis group, determined that DDR data from selected generator locations was more important for event analysis than FR data.

#### Recording of Electrical Quantities

For effective fault analysis it is necessary to know values of all phase and neutral currents and all phase-to-neutral voltages. Based on such FR data it is possible to determine all fault types. FR data also augments SERs in evaluating circuit breaker operation.

#### Current Recordings

The required electrical quantities are normally directly measured. Certain quantities can be derived if sufficient data is measured, for example residual or neutral currents.

Since a Transmission System is generally well balanced, with phase currents having essentially similar magnitudes and phase angle differences of 120°, during normal conditions there is negligible neutral (residual) current. In case of a ground fault the resulting phase current imbalance produces residual current that can be either measured or calculated.

Neutral current, also known as ground or residual current  $I_r$ , is calculated as a sum of vectors of three phase currents:

$$I_r = 3 \cdot I_0 = I_A + I_B + I_C$$

$I_0$  - Zero-sequence current

$I_A, I_B, I_C$  - Phase current (vectors)

Another example of how required electrical quantities can be derived is based on Kirchhoff's Law. Fault currents for one of the BES Elements connected to a particular BES bus can be derived as a vectorial sum of fault currents recorded at the other BES Elements connected to that BES bus.

#### Voltage Recordings

Voltages are to be recorded or accurately determined at applicable BES buses.

#### Guideline for Requirement R4:

Pre- and post-trigger fault data along with the SER breaker data, all time stamped to a common clock at millisecond accuracy, aid in the analysis of protection System operations after a fault to determine if a protection System operated as designed. Generally speaking, BES faults persist for a very short time period, approximately 1 to 30 cycles, thus a 30-cycle record length provides adequate data. Multiple records allow for legacy microprocessor relays which, when time synchronized to a common clock, are capable of providing adequate fault data but not capable of providing fault data in a single record with 30-contiguous cycles total.

A minimum recording rate of 16 samples per cycle is required to get accurate waveforms and to get 1 millisecond resolution for any digital input which may be used for FR.

FR triggers can be set so that when the monitored value on the recording device goes above or below the trigger value, data is recorded. Requirement R4, sub-Part 4.3.1 specifies a neutral (residual) overcurrent trigger for ground faults. Requirement R4, sub-Part 4.3.2 specifies a phase undervoltage or overcurrent trigger for phase-to-phase faults.

#### Guideline for Requirement R5:

DDR data is used for wide-area Disturbance monitoring to determine the System's electromechanical transient and post-transient response and validate System model performance. DDR is typically located based on strategic studies which include angular, frequency, voltage, and oscillation stability. However, for adequately monitoring the System's dynamic response and ensuring sufficient coverage to determine System performance, DDR is required for key BES Elements in addition to a minimum requirement of DDR coverage.

Each ~~Responsible Entity~~ Reliability Coordinator (PC or RC) is required to identify sufficient DDR data capture for, at a minimum, one BES Element and then one additional BES Element per 3,000 MW of historical simultaneous peak System Demand. This DDR data is included to provide adequate System wide coverage across an Interconnection. To clarify, if any of the key BES Elements requiring DDR monitoring are within the ~~Responsible Entity's~~ Reliability Coordinator ~~Area~~, DDR data capability is required. If a ~~Responsible Entity~~ Reliability Coordinator (PC or RC) does not meet the requirements of Part 5.1, additional coverage had to be specified.

Loss of large generating resources poses a frequency and angular stability risk for all Interconnections across North America. Data capturing the dynamic response of these machines during a Disturbance helps the analysis of large Disturbances. Having data regarding generator dynamic response to Disturbances greatly improves understanding of **why** an event occurs rather than what occurred. To determine and provide the basis for unit size criteria, the DMSDT acquired specific generating unit data from NERC's Generating Availability Data System (GADS) program. The data contained generating unit size information for each generating unit in North America which was reported in 2013 to the NERC GADS program. The DMSDT analyzed the spreadsheet data to determine: (i) how many units were above or below selected size thresholds; and (ii) the aggregate sum of the ratings of the units within the boundaries of those



thresholds. Statistical information about this data was then produced, i.e. averages, means and percentages. The DMSDT determined the following basic information about the generating units of interest (current North America fleet, i.e. units reporting in 2013) included in the spreadsheet:

- The number of individual generating units in total included in the spreadsheet.
- The number of individual generating units rated at 20 MW or larger included in the spreadsheet. These units would generally require that their owners be registered as GOs in the NERC CMEP.
- The total number of units within selected size boundaries.
- The aggregate sum of ratings, in MWs, of the units within the boundaries of those thresholds.

The information in the spreadsheet does not provide information by which the plant information location of each unit can be determined, i.e. the DMSDT could not use the information to determine which units were located together at a given generation site or facility.

From this information, the DMSDT was able to reasonably speculate the generating unit size thresholds proposed in Requirement R5, sub-Part 5.1.1 of the standard. Generating resources intended for DDR data recording are those individual units with gross nameplate ratings “greater than or equal to 500 MVA”. The 500 MVA individual unit size threshold was selected because this number roughly accounts for 47 percent of the generating capacity in NERC footprint while only requiring DDR coverage on about 12.5 percent of the generating units. As mentioned, there was no data pertaining to unit location for aggregating plant/facility sizes. However, Requirement R5, sub-Part 5.1.1 is included to capture larger units located at large generating plants which could pose a stability risk to the System if multiple large units were lost due to electrical or non-electrical contingencies. For generating plants, each individual generator at the plant/facility with a gross nameplate rating greater than or equal to 300 MVA must have DDR where the gross nameplate rating of the plant/facility is greater than or equal to 1,000 MVA. The 300 MVA threshold was chosen based on the DMSDT’s judgment and experience. The incremental impact to the number of units requiring monitoring is expected to be relatively low. For combined cycle plants where only one generator has a rating greater than or equal to 300MVA, that is the only generator that would need DDR.

Permanent System Operating Limits (SOLs) are used to operate the System within reliable and secure limits. In particular, SOLs related to angular or voltage stability have a significant impact on BES reliability and performance. Therefore, at least one BES Element of an SOL should be monitored.

The draft standard requires “One or more BES Elements that are part of an Interconnection Reliability Operating Limits (IROLs).” Interconnection Reliability Operating Limits (IROLs) are included because the risk of violating these limits poses a risk to System stability and the potential for cascading outages. IROLs may be defined by a single or multiple monitored BES Element(s) and contingent BES Element(s). The standard does not dictate selection of the



contingent and/or monitored BES Elements. Rather the Drafting Team believes this determination is best made by the ~~Responsible Entity~~Reliability Coordinator for each IROL considered based on the severity of violating this IROL.

Locations where an undervoltage load shedding (UVLS) program is deployed are prone to voltage instability since they are generally areas of significant Demand. The ~~Responsible Entity~~Reliability Coordinator (PC or RC) will identify these areas where a UVLS is in service and identify a useful and effective BES Element to monitor for DDR such that action of the UVLS or voltage instability on the BES could be captured. For example, a major 500kV or 230kV substation on the EHV System close to the load pocket where the UVLS is deployed would likely be a valuable electrical location for DDR coverage and would aid in post-Disturbance analysis of the load area's response to large System excursions (voltage, frequency, etc.).

#### **Guideline for Requirement R6:**

DDR data shows transient response to System Disturbances after a fault is cleared (post-fault), under a relatively balanced operating condition. Therefore, it is sufficient to provide a single phase-to-neutral voltage or positive sequence voltage. Recording of all three phases of a circuit is not required, although this may be used to compute and record the positive sequence voltage.

The bus where a voltage measurement is required is based on the list of BES Elements defined by the ~~Responsible Entity~~Reliability Coordinator (PC or RC) in Requirement R5. The intent of the standard is not to require a separate voltage measurement of each BES Element where a common bus voltage measurement is available. For example, a breaker-and-a-half or double-bus configuration with a North (or East) Bus and South (or West) Bus, would require both buses to have voltage recording because either can be taken out of service indefinitely with the targeted BES Element remaining in service. This may be accomplished either by recording both bus voltages separately, or by providing a selector switch to connect either of the bus voltage sources to a single recording input of the DDR device. This component of the requirement is therefore included to mitigate the potential of failed frequency, phase angle, real power, and reactive power calculations due to voltage measurements removed from service while sufficient voltage measurement is actually available during these operating conditions.

It must be emphasized that the data requirements for PRC-002-~~2-3~~ are based on a System configuration assuming all normally closed circuit breakers on a bus are closed.

When current recording is required, it should be on the same phase as the voltage recording taken at the location if a single phase-to-neutral voltage is provided. Positive sequence current recording is also acceptable.

For all circuits where current recording is required, Real and Reactive Power will be recorded on a three phase basis. These recordings may be derived either from phase quantities or from positive sequence quantities.

**Guideline for Requirement R7:**

All Guidelines specified for Requirement R6 apply to Requirement R7. Since either the high- or low-side windings of the generator step-up transformer (GSU) may be connected in delta, phase-to-phase voltage recording is an acceptable voltage recording. As was explained in the Guideline for Requirement R6, the BES is operating under a relatively balanced operating condition and, if needed, phase-to-neutral quantities can be derived from phase-to-phase quantities.

Again it must be emphasized that the data requirements for PRC-002-~~23~~ are based on a System configuration assuming all normally closed circuit breakers on a bus are closed.

**Guideline for Requirement R8:**

Wide-area System outages are generally an evolving sequence of events that occur over an extended period of time, making DDR data essential for event analysis. Pre- and post-contingency data helps identify the causes and effects of each event leading to the outages. This drives a need for continuous recording and storage to ensure sufficient data is available for the entire Disturbance.

Transmission Owners and Generator Owners are required to have continuous DDR for the BES Elements identified in Requirement R6. However, this requirement recognizes that legacy equipment may exist for some BES Elements that do not have continuous data recording capabilities. For equipment that was installed prior to the effective date of the standard, triggered DDR records of three minutes are acceptable using at least one of the trigger types specified in Requirement R8, Part 8.2:

- Off nominal frequency triggers are used to capture high- or low-frequency excursions of significant size based on the Interconnection size and inertia.
- Rate of change of frequency triggers are used to capture major changes in System frequency which could be caused by large changes in generation or load, or possibly changes in System impedance.
- The undervoltage trigger specified in this standard is provided to capture possible sustained undervoltage conditions such as Fault Induced Delayed Voltage Recovery (FIDVR) events. A sustained voltage of 85 percent is outside normal schedule operating voltages and is sufficiently low to capture abnormal voltage conditions on the BES.

**Guideline for Requirement R9:**

DDR data contains the dynamic response of a power System to a Disturbance and is used for analyzing complex power System events. This recording is typically used to capture short-term and long-term Disturbances, such as a power swing. Since the data of interest is changing over time, DDR data is normally stored in the form of RMS values or phasor values, as opposed to directly sampled data as found in FR data.

The issue of the sampling rate used in a recording instrument is quite important for at least two reasons: the anti-aliasing filter selection and accuracy of signal representation. The anti-aliasing filter selection is associated with the requirement of a sampling rate at least twice the highest frequency of a sampled signal. At the same time, the accuracy of signal representation is also dependent on the selection of the sampling rate. In general, the higher the sampling rate, the better the representation. In the abnormal conditions of interest (e.g. faults or other Disturbances); the input signal may contain frequencies in the range of 0-400 Hz. Hence, the rate of 960 samples per second (16 samples/cycle) is considered an adequate sampling rate that satisfies the input signal requirements.

In general, dynamic events of interest are: inter-area oscillations, local generator oscillations, wind turbine generator torsional modes, HVDC control modes, exciter control modes, and steam turbine torsional modes. Their frequencies range from 0.1-20 Hz. In order to reconstruct these dynamic events, a minimum recording time of 30 times per second is required.

#### **Guideline for Requirement R10:**

Time synchronization of Disturbance monitoring data allows for the time alignment of large volumes of geographically dispersed data records from diverse recording sources. A universally recognized time standard is necessary to provide the foundation for this alignment. Coordinated Universal Time (UTC) is the foundation used for the time alignment of records. It is an international time standard utilizing atomic clocks for generating precision time measurements at fractions of a second levels. The local time offset, expressed as a negative number, is the difference between UTC and the local time zone where the measurements are recorded.

Accuracy of time synchronization applies only to the clock used for synchronizing the monitoring equipment.

Time synchronization accuracy is specified in response to Recommendation 12b in the NERC August, 2003, Blackout Final NERC Report Section V Conclusions and Recommendations:

“Recommendation 12b: Facilities owners shall, in accordance with regional criteria, upgrade existing dynamic recorders to include GPS time synchronization...”

Also, from the U.S.-Canada Power System Outage Task Force Interim Report: Causes of the August 14th Blackout, November 2003, in the United States and Canada, page 103:

“Establishing a precise and accurate sequence of outage-related events was a critical building block for the other parts of the investigation. One of the key problems in developing this sequence was that although much of the data pertinent to an event was time-stamped, there was some variance from source to source in how the time-stamping was done, and not all of the time-stamps were synchronized...”

From NPCC’s SP6 Report Synchronized Event Data Reporting, revised March 31, 2005, the investigation by the authoring working group revealed that existing GPS receivers can be

expected to provide a time code output which has an uncertainty on the order of 1 millisecond, uncertainty being a quantitative descriptor.

**Guideline for Requirement R11:**

This requirement directs the applicable entities, upon requests from the **Responsible Entity Reliability Coordinator**, Regional Entity or NERC, to provide SER and FR data for BES buses determined in Requirement R1 and DDR data for BES Elements determined as per Requirement R5. To facilitate the analysis of BES Disturbances, it is important that the data is provided to the requestor within a reasonable period of time.

Requirement R11, Part 11.1 specifies the maximum time frame of 30-calendar days to provide the data. Thirty calendar days is a reasonable time frame to allow for the collection of data, and submission to the requestor. An entity may request an extension of the 30-day submission requirement. If granted by the requestor, the entity must submit the data within the approved extended time.

Requirement R11, Part 11.2 specifies that the minimum time period of 10-calendar days inclusive of the day the data was recorded for which the data will be retrievable. With the equipment in use that has the capability of recording data, having the data retrievable for the 10-calendar days is realistic and doable. It is important to note that applicable entities should account for any expected delays in retrieving data and this may require devices to have data available for more than 10 days. To clarify the 10-calendar day time frame, an incident occurs on Day 1. If a request for data is made on Day 6, then that data has to be provided to the requestor within 30-calendar days after a request or a granted time extension. However, if a request for the data is made on Day 11, that is outside the 10-calendar days specified in the requirement, and an entity would not be out of compliance if it did not have the data.

Requirement R11, Part 11.3 specifies a Comma Separated Value (CSV) format according to Attachment 2 for the SER data. It is necessary to establish a standard format as it will be incorporated with other submitted data to provide a detailed sequence of events timeline of a power System Disturbance.

Requirement R11, Part 11.4 specifies the IEEE C37.111 COMTRADE format for the FR and DDR data. The IEEE C37.111 is the Standard for Common Format for Transient Data Exchange and is well established in the industry. It is necessary to specify a standard format as multiple submissions of data from many sources will be incorporated to provide a detailed analysis of a power System Disturbance. The latest revision of COMTRADE (C37.111-2013) includes an annex describing the application of the COMTRADE standard to synchophasor data.

Requirement R11, Part 11.5 specifies the IEEE C37.232 COMNAME format for naming the data files of the SER, FR and DDR. The IEEE C37.232 is the Standard for Common Format for Naming Time Sequence Data Files. The first version was approved in 2007. From the August 14, 2003 blackout there were thousands of Fault Recording data files collected. The collected data files did not have a common naming convention and it was therefore difficult to discern which files came from which utilities and which ones were captured by which devices. The lack of a common naming practice seriously hindered the investigation process. Subsequently, and in its

initial report on the blackout, NERC stressed the need for having a common naming practice and listed it as one of its top ten recommendations.

**Guideline for Requirement R12:**

This requirement directs the respective owners of Transmission and Generator equipment to be alert to the proper functioning of equipment used for SER, FR, and DDR data capabilities for the BES buses and BES Elements, which were established in Requirements R1 and R5. The owners are to restore the capability within 90-calendar days of discovery of a failure. This requirement is structured to recognize that the existence of a “reasonable” amount of capability out-of-service does not result in lack of sufficient data for coverage of the System. Furthermore, 90-calendar days is typically sufficient time for repair or maintenance to be performed. However, in recognition of the fact that there may be occasions for which it is not possible to restore the capability within 90-calendar days, the requirement further provides that, for such cases, the entity submit a Corrective Action Plan (CAP) to the Regional Entity and implement it. These actions are considered to be appropriate to provide for robust and adequate data availability.

Exhibit A-7

PRC-023-5 (Clean and Redline to Last Approved)

## A. Introduction

1. **Title:** Transmission Relay Loadability
2. **Number:** PRC-023-5
3. **Purpose:** Protective relay settings shall not limit transmission loadability; not interfere with system operators' ability to take remedial action to protect system reliability and; be set to reliably detect all fault conditions and protect the electrical network from these faults.
4. **Applicability:**
  - 4.1. **Functional Entity:**
    - 4.1.1 Transmission Owner with load-responsive phase protection systems as described in PRC-023-5 - Attachment A, applied at the terminals of the circuits defined in 4.2.1 (*Circuits Subject to Requirements R1 – R5*).
    - 4.1.2 Generator Owner with load-responsive phase protection systems as described in PRC-023-5 - Attachment A, applied at the terminals of the circuits defined in 4.2.1 (*Circuits Subject to Requirements R1 – R5*).
    - 4.1.3 Distribution Provider with load-responsive phase protection systems as described in PRC-023-5 - Attachment A, applied at the terminals of the circuits defined in 4.2.1 (*Circuits Subject to Requirements R1 – R5*), provided those circuits have bi-directional flow capabilities.
    - 4.1.4 Planning Coordinator
  - 4.2. **Circuits:**
    - 4.2.1 **Circuits Subject to Requirements R1 – R5:**
      - 4.2.1.1 Transmission lines operated at 200 kV and above, except Elements that connect the GSU transformer(s) to the Transmission system that are used exclusively to export energy directly from a BES generating unit or generating plant. Elements may also supply generating plant loads.
      - 4.2.1.2 Transmission lines operated at 100 kV to 200 kV selected by the Planning Coordinator in accordance with Requirement R6.
      - 4.2.1.3 Transmission lines operated below 100 kV that are part of the BES and selected by the Planning Coordinator in accordance with Requirement R6.
      - 4.2.1.4 Transformers with low voltage terminals connected at 200 kV and above.
      - 4.2.1.5 Transformers with low voltage terminals connected at 100 kV to 200 kV selected by the Planning Coordinator in accordance with Requirement R6.
      - 4.2.1.6 Transformers with low voltage terminals connected below 100 kV that are part of the BES and selected by the Planning Coordinator in accordance with Requirement R6.
    - 4.2.2 **Circuits Subject to Requirement R6:**
      - 4.2.2.1 Transmission lines operated at 100 kV to 200 kV and transformers with low voltage terminals connected at 100 kV to 200 kV, except Elements that connect the GSU transformer(s) to the Transmission system that are used exclusively to export energy directly from a BES generating unit or generating plant. Elements may also supply generating plant loads.

**4.2.2.2** Transmission lines operated below 100 kV and transformers with low voltage terminals connected below 100 kV that are part of the BES, except Elements that connect the GSU transformer(s) to the Transmission system that are used exclusively to export energy directly from a BES generating unit or generating plant. Elements may also supply generating plant loads.

**5. Effective Dates:** See Implementation.

## B. Requirements

**R1.** Each Transmission Owner, Generator Owner, and Distribution Provider shall use any one of the following criteria (Requirement R1, criteria 1 through 13) for any specific circuit terminal to prevent its phase protective relay settings from limiting transmission system loadability while maintaining reliable protection of the BES for all fault conditions. Each Transmission Owner, Generator Owner, and Distribution Provider shall evaluate relay loadability at 0.85 per unit voltage and a power factor angle of 30 degrees. [*Violation Risk Factor: High*] [*Time Horizon: Long Term Planning*].

### Criteria:

1. Set transmission line relays so they do not operate at or below 150% of the highest seasonal Facility Rating of a circuit, for the available defined loading duration nearest 4 hours (expressed in amperes).
2. Set transmission line relays so they do not operate at or below 115% of the highest seasonal 15-minute Facility Rating<sup>1</sup> of a circuit (expressed in amperes).
3. Set transmission line relays so they do not operate at or below 115% of the maximum theoretical power transfer capability (using a 90-degree angle between the sending-end and receiving-end voltages and either reactance or complex impedance) of the circuit (expressed in amperes) using one of the following to perform the power transfer calculation:
  - An infinite source (zero source impedance) with a 1.00 per unit bus voltage at each end of the line.
  - An impedance at each end of the line, which reflects the actual system source impedance with a 1.05 per unit voltage behind each source impedance.
4. Set transmission line relays on series compensated transmission lines so they do not operate at or below the maximum power transfer capability of the line, determined as the greater of:
  - 115% of the highest emergency rating of the series capacitor.
  - 115% of the maximum power transfer capability of the circuit (expressed in amperes), calculated in accordance with Requirement R1, criterion 3, using the full line inductive reactance.
5. Set transmission line relays on weak source systems so they do not operate at or below 170% of the maximum end-of-line three-phase fault magnitude (expressed in amperes).
6. Not used.

---

<sup>1</sup> When a 15-minute rating has been calculated and published for use in real-time operations, the 15-minute rating can be used to establish the loadability requirement for the protective relays.



7. Set transmission line relays applied at the load center terminal, remote from generation stations, so they do not operate at or below 115% of the maximum current flow from the load to the generation source under any system configuration.
8. Set transmission line relays applied on the bulk system-end of transmission lines that serve load remote to the system so they do not operate at or below 115% of the maximum current flow from the system to the load under any system configuration.
9. Set transmission line relays applied on the load-end of transmission lines that serve load remote to the bulk system so they do not operate at or below 115% of the maximum current flow from the load to the system under any system configuration.
10. Set transformer fault protection relays and transmission line relays on transmission lines terminated only with a transformer so that the relays do not operate at or below the greater of:
  - 150% of the applicable maximum transformer nameplate rating (expressed in amperes), including the forced cooled ratings corresponding to all installed supplemental cooling equipment.
  - 115% of the highest operator established emergency transformer rating.
- 10.1 Set load-responsive transformer fault protection relays, if used, such that the protection settings do not expose the transformer to a fault level and duration that exceeds the transformer's mechanical withstand capability<sup>2</sup>.
11. For transformer overload protection relays that do not comply with the loadability component of Requirement R1, criterion 10 set the relays according to one of the following:
  - Set the relays to allow the transformer to be operated at an overload level of at least 150% of the maximum applicable nameplate rating, or 115% of the highest operator established emergency transformer rating, whichever is greater, for at least 15 minutes to provide time for the operator to take controlled action to relieve the overload.
  - Install supervision for the relays using either a top oil or simulated winding hot spot temperature element set no less than 100° C for the top oil temperature or no less than 140° C for the winding hot spot temperature<sup>3</sup>.
12. When the desired transmission line capability is limited by the requirement to adequately protect the transmission line, set the transmission line distance relays to a maximum of 125% of the apparent impedance (at the impedance angle of the transmission line) subject to the following constraints:
  - a. Set the maximum torque angle (MTA) to 90 degrees or the highest supported by the manufacturer.
  - b. Evaluate the relay loadability in amperes at the relay trip point at 0.85 per unit voltage and a power factor angle of 30 degrees.
  - c. Include a relay setting component of 87% of the current calculated in Requirement R1, criterion 12 in the Facility Rating determination for the circuit.

---

<sup>2</sup> As illustrated by the “dotted line” in IEEE C57.109-1993 - *IEEE Guide for Liquid-Immersed Transformer Through-Fault-Current Duration*, Clause 4.4, Figure 4.

<sup>3</sup> IEEE standard C57.91, Tables 7 and 8, specify that transformers are to be designed to withstand a winding hot spot temperature of 180 degrees C, and Annex A cautions that bubble formation may occur above 140 degrees C.

- 13.** Where other situations present practical limitations on circuit capability, set the phase protection relays so they do not operate at or below 115% of such limitations.
- R2.** Each Transmission Owner, Generator Owner, and Distribution Provider shall set its out-of-step blocking elements to allow tripping of phase protective relays for faults that occur during the loading conditions used to verify transmission line relay loadability per Requirement R1. *[Violation Risk Factor: High] [Time Horizon: Long Term Planning]*
- R3.** Each Transmission Owner, Generator Owner, and Distribution Provider that uses a circuit capability with the practical limitations described in Requirement R1, criterion 7, 8, 9, 12, or 13 shall use the calculated circuit capability as the Facility Rating of the circuit and shall obtain the agreement of the Planning Coordinator, Transmission Operator, and Reliability Coordinator with the calculated circuit capability. *[Violation Risk Factor: Medium] [Time Horizon: Long Term Planning]*
- R4.** Each Transmission Owner, Generator Owner, and Distribution Provider that chooses to use Requirement R1 criterion 2 as the basis for verifying transmission line relay loadability shall provide its Planning Coordinator, Transmission Operator, and Reliability Coordinator with an updated list of circuits associated with those transmission line relays at least once each calendar year, with no more than 15 months between reports. *[Violation Risk Factor: Lower] [Time Horizon: Long Term Planning]*
- R5.** Each Transmission Owner, Generator Owner, and Distribution Provider that sets transmission line relays according to Requirement R1 criterion 12 shall provide an updated list of the circuits associated with those relays to its Regional Entity at least once each calendar year, with no more than 15 months between reports, to allow the ERO to compile a list of all circuits that have protective relay settings that limit circuit capability. *[Violation Risk Factor: Lower] [Time Horizon: Long Term Planning]*
- R6.** Each Planning Coordinator shall conduct an assessment at least once each calendar year, with no more than 15 months between assessments, by applying the criteria in PRC-023-5, Attachment B to determine the circuits in its Planning Coordinator area for which Transmission Owners, Generator Owners, and Distribution Providers must comply with Requirements R1 through R5. The Planning Coordinator shall: *[Violation Risk Factor: High] [Time Horizon: Long Term Planning]*
- 6.1** Maintain a list of circuits subject to PRC-023-5 per application of Attachment B, including identification of the first calendar year in which any criterion in PRC-023-5, Attachment B applies.
- 6.2** Provide the list of circuits to all Regional Entities, Reliability Coordinators, Transmission Owners, Generator Owners, and Distribution Providers within its Planning Coordinator area within 30 calendar days of the establishment of the initial list and within 30 calendar days of any changes to that list.

### **C. Measures**

- M1.** Each Transmission Owner, Generator Owner, and Distribution Provider shall have evidence such as spreadsheets or summaries of calculations to show that each of its transmission relays is set according to one of the criteria in Requirement R1, criterion 1 through 13 and shall have evidence such as coordination curves or summaries of calculations that show that relays set per criterion 10 do not expose the transformer to fault levels and durations beyond those indicated in the standard. (R1)

- M2.** Each Transmission Owner, Generator Owner, and Distribution Provider shall have evidence such as spreadsheets or summaries of calculations to show that each of its out-of-step blocking elements is set to allow tripping of phase protective relays for faults that occur during the loading conditions used to verify transmission line relay loadability per Requirement R1. (R2)
- M3.** Each Transmission Owner, Generator Owner, and Distribution Provider with transmission relays set according to Requirement R1, criterion 7, 8, 9, 12, or 13 shall have evidence such as Facility Rating spreadsheets or Facility Rating database to show that it used the calculated circuit capability as the Facility Rating of the circuit and evidence such as dated correspondence that the resulting Facility Rating was agreed to by its associated Planning Coordinator, Transmission Operator, and Reliability Coordinator. (R3)
- M4.** Each Transmission Owner, Generator Owner, or Distribution Provider that sets transmission line relays according to Requirement R1, criterion 2 shall have evidence such as dated correspondence to show that it provided its Planning Coordinator, Transmission Operator, and Reliability Coordinator with an updated list of circuits associated with those transmission line relays within the required timeframe. The updated list may either be a full list, a list of incremental changes to the previous list, or a statement that there are no changes to the previous list. (R4)
- M5.** Each Transmission Owner, Generator Owner, or Distribution Provider that sets transmission line relays according to Requirement R1, criterion 12 shall have evidence such as dated correspondence that it provided an updated list of the circuits associated with those relays to its Regional Entity within the required timeframe. The updated list may either be a full list, a list of incremental changes to the previous list, or a statement that there are no changes to the previous list. (R5)
- M6.** Each Planning Coordinator shall have evidence such as power flow results, calculation summaries, or study reports that it used the criteria established within PRC-023-5, Attachment B to determine the circuits in its Planning Coordinator area for which applicable entities must comply with the standard as described in Requirement R6. The Planning Coordinator shall have a dated list of such circuits and shall have evidence such as dated correspondence that it provided the list to the Regional Entities, Reliability Coordinators, Transmission Owners, Generator Owners, and Distribution Providers within its Planning Coordinator area within the required timeframe. (R6)

## **D. Compliance**

### **1. Compliance Monitoring Process**

#### **1.1. Compliance Enforcement Authority**

As defined in the NERC Rules of Procedure, “Compliance Enforcement Authority” means NERC or the Regional Entity in their respective roles of monitoring and enforcing compliance with the NERC Reliability Standards.

#### **1.2. Data Retention**

The Transmission Owner, Generator Owner, Distribution Provider and Planning Coordinator shall keep data or evidence to show compliance as identified below unless directed by its Compliance Enforcement Authority to retain specific evidence for a longer period of time as part of an investigation:

The Transmission Owner, Generator Owner, and Distribution Provider shall each retain documentation to demonstrate compliance with Requirements R1 through R5 for three calendar years.

The Planning Coordinator shall retain documentation of the most recent review process required in Requirement R6. The Planning Coordinator shall retain the most recent list of circuits in its Planning Coordinator area for which applicable entities must comply with the standard, as determined per Requirement R6.

If a Transmission Owner, Generator Owner, Distribution Provider, or Planning Coordinator is found non-compliant, it shall keep information related to the non-compliance until found compliant or for the time specified above, whichever is longer.

The Compliance Enforcement Authority shall keep the last audit record and all requested and submitted subsequent audit records.

**1.3. Compliance Monitoring and Assessment Processes**

- Compliance Audit
- Self-Certification
- Spot Checking
- Compliance Violation Investigation
- Self-Reporting
- Complaint

**1.4. Additional Compliance Information**

None.

**Violation Severity Levels:**

Requirement	Lower	Moderate	High	Severe
<b>R1</b>	N/A	N/A	N/A	<p>The responsible entity did not use any one of the following criteria (Requirement R1 criterion 1 through 13) for any specific circuit terminal to prevent its phase protective relay settings from limiting transmission system loadability while maintaining reliable protection of the BES for all fault conditions.</p> <p>OR</p> <p>The responsible entity did not evaluate relay loadability at 0.85 per unit voltage and a power factor angle of 30 degrees.</p>
<b>R2</b>	N/A	N/A	N/A	<p>The responsible entity failed to ensure that its out-of-step blocking elements allowed tripping of phase protective relays for faults that occur during the loading conditions used to verify transmission line relay loadability per Requirement R1.</p>
<b>R3</b>	N/A	N/A	N/A	<p>The responsible entity that uses a circuit capability with the practical limitations described in Requirement R1 criterion 7, 8, 9, 12, or 13 did not use the calculated circuit capability as the Facility Rating of the circuit.</p>

**Standard PRC-023-5 — Transmission Relay Loadability**

Requirement	Lower	Moderate	High	Severe
				<p>OR</p> <p>The responsible entity did not obtain the agreement of the Planning Coordinator, Transmission Operator, and Reliability Coordinator with the calculated circuit capability.</p>
<b>R4</b>	N/A	N/A	N/A	<p>The responsible entity did not provide its Planning Coordinator, Transmission Operator, and Reliability Coordinator with an updated list of circuits that have transmission line relays set according to the criteria established in Requirement R1 criterion 2 at least once each calendar year, with no more than 15 months between reports.</p>
<b>R5</b>	N/A	N/A	N/A	<p>The responsible entity did not provide its Regional Entity, with an updated list of circuits that have transmission line relays set according to the criteria established in Requirement R1 criterion 12 at least once each calendar year, with no more than 15 months between reports.</p>
<b>R6</b>	N/A	<p>The Planning Coordinator used the criteria established within Attachment B to determine the circuits in its Planning Coordinator area for which applicable entities must comply with the standard and met parts 6.1 and 6.2, but more</p>	<p>The Planning Coordinator used the criteria established within Attachment B to determine the circuits in its Planning Coordinator area for which applicable entities must comply with the standard and met parts 6.1 and 6.2, but 24</p>	<p>The Planning Coordinator failed to use the criteria established within Attachment B to determine the circuits in its Planning Coordinator area for which applicable entities must comply with the standard.</p>

Standard PRC-023-5 — Transmission Relay Loadability

Requirement	Lower	Moderate	High	Severe
		<p>than 15 months and less than 24 months lapsed between assessments.</p> <p>OR</p> <p>The Planning Coordinator used the criteria established within Attachment B at least once each calendar year, with no more than 15 months between assessments to determine the circuits in its Planning Coordinator area for which applicable entities must comply with the standard and met 6.1 and 6.2 but failed to include the calendar year in which any criterion in Attachment B first applies.</p> <p>OR</p> <p>The Planning Coordinator used the criteria established within Attachment B at least once each calendar year, with no more than 15 months between assessments to determine the circuits in its Planning Coordinator area for which applicable entities must comply with the standard and met 6.1 and 6.2 but provided the list of circuits to the Reliability Coordinators, Transmission Owners, Generator Owners, and Distribution Providers within its Planning Coordinator area between 31 days and 45 days after</p>	<p>months or more lapsed between assessments.</p> <p>OR</p> <p>The Planning Coordinator used the criteria established within Attachment B at least once each calendar year, with no more than 15 months between assessments to determine the circuits in its Planning Coordinator area for which applicable entities must comply with the standard and met 6.1 and 6.2 but provided the list of circuits to the Reliability Coordinators, Transmission Owners, Generator Owners, and Distribution Providers within its Planning Coordinator area between 46 days and 60 days after list was established or updated. (part 6.2)</p>	<p>OR</p> <p>The Planning Coordinator used the criteria established within Attachment B, at least once each calendar year, with no more than 15 months between assessments to determine the circuits in its Planning Coordinator area for which applicable entities must comply with the standard but failed to meet parts 6.1 and 6.2.</p> <p>OR</p> <p>The Planning Coordinator used the criteria established within Attachment B at least once each calendar year, with no more than 15 months between assessments to determine the circuits in its Planning Coordinator area for which applicable entities must comply with the standard but failed to maintain the list of circuits determined according to the process described in Requirement R6. (part 6.1)</p> <p>OR</p> <p>The Planning Coordinator used the criteria established within Attachment B at least once each calendar year, with no more than 15 months between assessments to determine the circuits in its Planning Coordinator area for which applicable entities must comply with the standard and met</p>

**Standard PRC-023-5 — Transmission Relay Loadability**

---

Requirement	Lower	Moderate	High	Severe
		<p>the list was established or updated. (part 6.2)</p>		<p>6.1 but failed to provide the list of circuits to the Reliability Coordinators, Transmission Owners, Generator Owners, and Distribution Providers within its Planning Coordinator area or provided the list more than 60 days after the list was established or updated. (part 6.2)</p> <p>OR</p> <p>The Planning Coordinator failed to determine the circuits in its Planning Coordinator area for which applicable entities must comply with the standard.</p>



**E. Regional Differences**

None.

**F. Supplemental Technical Reference Document**

1. The following document is an explanatory supplement to the standard. It provides the technical rationale underlying the requirements in this standard. The reference document contains methodology examples for illustration purposes it does not preclude other technically comparable methodologies.

“Determination and Application of Practical Relaying Loadability Ratings,” Version 1.0, June 2008, prepared by the System Protection and Control Task Force of the NERC Planning Committee, available at:

[http://www.nerc.com/fileUploads/File/Standards/Relay\\_Loadability\\_Reference\\_Doc\\_Clean\\_Final\\_2008July3.pdf](http://www.nerc.com/fileUploads/File/Standards/Relay_Loadability_Reference_Doc_Clean_Final_2008July3.pdf)

**Version History**

Version	Date	Action	Change Tracking
1	February 12, 2008	Approved by Board of Trustees	New
1	March 19, 2008	Corrected typo in last sentence of Severe VSL for Requirement 3 — “then” should be “than.”	Errata
1	March 18, 2010	Approved by FERC	
1	Filed for approval April 19, 2010	Changed VRF for R3 from Medium to High; changed VSLs for R1, R2, R3 to binary Severe to comply with Order 733	Revision
2	March 10, 2011 approved by Board of Trustees	Revised to address initial set of directives from Order 733	Revision (Project 2010-13)
2	March 15, 2012	FERC order issued approving PRC-023-2 (approval becomes effective May 7, 2012)	
3	November 7, 2013	Adopted by NERC Board of Trustees	Supplemental SAR to Clarify applicability for consistency with PRC-025-1 and other minor corrections.

Version	Date	Action	Change Tracking
4	November 13, 2014	Adopted by the NERC Board of Trustees	Replaced references to Special Protection System and SPS with Remedial Action Scheme and RAS
4	November 19, 2015	FERC Order issued approving PRC-023-4. Docket No. RM15-13-000.	
5	May 13, 2021	Adopted by the NERC Board of Trustees	Revisions under Project 2015-09

**PRC-023-5 — Attachment A**

1. This standard includes any protective functions which could trip with or without time delay, on load current, including but not limited to:
  - 1.1. Phase distance.
  - 1.2. Out-of-step tripping.
  - 1.3. Switch-on-to-fault.
  - 1.4. Overcurrent relays.
  - 1.5. Communications aided protection schemes including but not limited to:
    - 1.5.1 Permissive overreach transfer trip (POTT).
    - 1.5.2 Permissive under-reach transfer trip (PUTT).
    - 1.5.3 Directional comparison blocking (DCB).
    - 1.5.4 Directional comparison unblocking (DCUB).
  - 1.6. Phase overcurrent supervisory elements (i.e., phase fault detectors) associated with current-based, communication-assisted schemes (i.e., pilot wire, phase comparison, and line current differential) where the scheme is capable of tripping for loss of communications.
2. The following protection systems are excluded from requirements of this standard:
  - 2.1. Relay elements that are only enabled when other relays or associated systems fail. For example:
    - Overcurrent elements that are only enabled during loss of potential conditions.
    - Elements that are only enabled during a loss of communications except as noted in section 1.6.
  - 2.2. Protection systems intended for the detection of ground fault conditions.
  - 2.3. Protection systems intended for protection during stable power swings.
  - 2.4. Not used.
  - 2.5. Relay elements used only for Remedial Action Schemes applied and approved in accordance with NERC Reliability Standards PRC-012 through PRC-017 or their successors.
  - 2.6. Protection systems that are designed only to respond in time periods which allow 15 minutes or greater to respond to overload conditions.
  - 2.7. Thermal emulation relays which are used in conjunction with dynamic Facility Ratings.
  - 2.8. Relay elements associated with dc lines.
  - 2.9. Relay elements associated with dc converter transformers.

## PRC-023-5 — Attachment B

### Circuits to Evaluate

- Transmission lines operated at 100 kV to 200 kV and transformers with low voltage terminals connected at 100 kV to 200 kV.
- Transmission lines operated below 100 kV and transformers with low voltage terminals connected below 100 kV that are part of the Bulk Electric System.

### Criteria

If any of the following criteria apply to a circuit, the applicable entity must comply with the standard for that circuit.

- B1.** The circuit is a monitored Facility of a permanent flowgate in the Eastern Interconnection, a major transfer path within the Western Interconnection as defined by the Regional Entity, or a comparable monitored Facility in the Québec Interconnection, that has been included to address reliability concerns for loading of that circuit, as confirmed by the applicable Planning Coordinator.
- B2.** The circuit is selected by the Planning Coordinator or Transmission Planner based on Planning Assessments of the Near-Term Transmission Planning Horizon that identify instances of instability, Cascading, or uncontrolled separation, that adversely impact the reliability of the Bulk Electric System for planning events.
- B3.** The circuit forms a path (as agreed to by the Generator Operator and the transmission entity) to supply off-site power to a nuclear plant as established in the Nuclear Plant Interface Requirements (NPIRs) pursuant to NUC-001.
- B4.** The circuit is identified through the following sequence of power flow analyses<sup>4</sup> performed by the Planning Coordinator for the one-to-five-year planning horizon:
- a. Simulate double contingency combinations selected by engineering judgment, without manual system adjustments in between the two contingencies (reflects a situation where a System Operator may not have time between the two contingencies to make appropriate system adjustments).
  - b. For circuits operated between 100 kV and 200 kV evaluate the post-contingency loading, in consultation with the Facility owner, against a threshold based on the Facility Rating assigned for that circuit and used in the power flow case by the Planning Coordinator.

---

<sup>4</sup> Past analyses may be used to support the assessment if no material changes to the system have occurred since the last assessment

- c. When more than one Facility Rating for that circuit is available in the power flow case, the threshold for selection will be based on the Facility Rating for the loading duration nearest four hours.
  - d. The threshold for selection of the circuit will vary based on the loading duration assumed in the development of the Facility Rating.
    - i. If the Facility Rating is based on a loading duration of up to and including four hours, the circuit must comply with the standard if the loading exceeds 115% of the Facility Rating.
    - ii. If the Facility Rating is based on a loading duration greater than four and up to and including eight hours, the circuit must comply with the standard if the loading exceeds 120% of the Facility Rating.
    - iii. If the Facility Rating is based on a loading duration of greater than eight hours, the circuit must comply with the standard if the loading exceeds 130% of the Facility Rating.
  - e. Radially operated circuits serving only load are excluded.
- B5.** The circuit is selected by the Planning Coordinator based on technical studies or assessments, other than those specified in criteria B1 through B4, in consultation with the Facility owner.
- B6.** The circuit is mutually agreed upon for inclusion by the Planning Coordinator and the Facility owner.

## A. Introduction

1. **Title:** Transmission Relay Loadability
2. **Number:** PRC-023-~~54~~
3. **Purpose:** Protective relay settings shall not limit transmission loadability; not interfere with system operators' ability to take remedial action to protect system reliability and; be set to reliably detect all fault conditions and protect the electrical network from these faults.
4. **Applicability:**
  - 4.1. **Functional Entity:**
    - 4.1.1 Transmission Owner with load-responsive phase protection systems as described in PRC-023-~~45~~ - Attachment A, applied at the terminals of the circuits defined in 4.2.1 (*Circuits Subject to Requirements R1 – R5*).
    - 4.1.2 Generator Owner with load-responsive phase protection systems as described in PRC-023-~~45~~ - Attachment A, applied at the terminals of the circuits defined in 4.2.1 (*Circuits Subject to Requirements R1 – R5*).
    - 4.1.3 Distribution Provider with load-responsive phase protection systems as described in PRC-023-~~45~~ - Attachment A, applied at the terminals of the circuits defined in 4.2.1 (*Circuits Subject to Requirements R1 – R5*), provided those circuits have bi-directional flow capabilities.
    - 4.1.4 Planning Coordinator
  - 4.2. **Circuits:**
    - 4.2.1 **Circuits Subject to Requirements R1 – R5:**
      - 4.2.1.1 Transmission lines operated at 200 kV and above, except Elements that connect the GSU transformer(s) to the Transmission system that are used exclusively to export energy directly from a BES generating unit or generating plant. Elements may also supply generating plant loads.
      - 4.2.1.2 Transmission lines operated at 100 kV to 200 kV selected by the Planning Coordinator in accordance with Requirement R6.
      - 4.2.1.3 Transmission lines operated below 100 kV that are part of the BES and selected by the Planning Coordinator in accordance with Requirement R6.
      - 4.2.1.4 Transformers with low voltage terminals connected at 200 kV and above.
      - 4.2.1.5 Transformers with low voltage terminals connected at 100 kV to 200 kV selected by the Planning Coordinator in accordance with Requirement R6.
      - 4.2.1.6 Transformers with low voltage terminals connected below 100 kV that are part of the BES and selected by the Planning Coordinator in accordance with Requirement R6.
    - 4.2.2 **Circuits Subject to Requirement R6:**
      - 4.2.2.1 Transmission lines operated at 100 kV to 200 kV and transformers with low voltage terminals connected at 100 kV to 200 kV, except Elements that connect the GSU transformer(s) to the Transmission system that are used exclusively to export energy directly from a BES generating unit or generating plant. Elements may also supply generating plant loads.

4.2.2.2 Transmission lines operated below 100 kV and transformers with low voltage terminals connected below 100 kV that are part of the BES, except Elements that connect the GSU transformer(s) to the Transmission system that are used exclusively to export energy directly from a BES generating unit or generating plant. Elements may also supply generating plant loads.

5. **Effective Dates:** ~~See Implementation Plan for (?)~~ See Implementation Plan for the Revised Definition of “Remedial Action Scheme”.

## B. Requirements

**R1.** Each Transmission Owner, Generator Owner, and Distribution Provider shall use any one of the following criteria (Requirement R1, criteria 1 through 13) for any specific circuit terminal to prevent its phase protective relay settings from limiting transmission system loadability while maintaining reliable protection of the BES for all fault conditions. Each Transmission Owner, Generator Owner, and Distribution Provider shall evaluate relay loadability at 0.85 per unit voltage and a power factor angle of 30 degrees. [*Violation Risk Factor: High*] [*Time Horizon: Long Term Planning*].

### Criteria:

1. Set transmission line relays so they do not operate at or below 150% of the highest seasonal Facility Rating of a circuit, for the available defined loading duration nearest 4 hours (expressed in amperes).
2. Set transmission line relays so they do not operate at or below 115% of the highest seasonal 15-minute Facility Rating<sup>1</sup> of a circuit (expressed in amperes).
3. Set transmission line relays so they do not operate at or below 115% of the maximum theoretical power transfer capability (using a 90-degree angle between the sending-end and receiving-end voltages and either reactance or complex impedance) of the circuit (expressed in amperes) using one of the following to perform the power transfer calculation:
  - An infinite source (zero source impedance) with a 1.00 per unit bus voltage at each end of the line.
  - An impedance at each end of the line, which reflects the actual system source impedance with a 1.05 per unit voltage behind each source impedance.
4. Set transmission line relays on series compensated transmission lines so they do not operate at or below the maximum power transfer capability of the line, determined as the greater of:
  - 115% of the highest emergency rating of the series capacitor.
  - 115% of the maximum power transfer capability of the circuit (expressed in amperes), calculated in accordance with Requirement R1, criterion 3, using the full line inductive reactance.
5. Set transmission line relays on weak source systems so they do not operate at or below 170% of the maximum end-of-line three-phase fault magnitude (expressed in amperes).
6. Not used.

---

<sup>1</sup> When a 15-minute rating has been calculated and published for use in real-time operations, the 15-minute rating can be used to establish the loadability requirement for the protective relays.

7. Set transmission line relays applied at the load center terminal, remote from generation stations, so they do not operate at or below 115% of the maximum current flow from the load to the generation source under any system configuration.
8. Set transmission line relays applied on the bulk system-end of transmission lines that serve load remote to the system so they do not operate at or below 115% of the maximum current flow from the system to the load under any system configuration.
9. Set transmission line relays applied on the load-end of transmission lines that serve load remote to the bulk system so they do not operate at or below 115% of the maximum current flow from the load to the system under any system configuration.
10. Set transformer fault protection relays and transmission line relays on transmission lines terminated only with a transformer so that the relays do not operate at or below the greater of:
  - 150% of the applicable maximum transformer nameplate rating (expressed in amperes), including the forced cooled ratings corresponding to all installed supplemental cooling equipment.
  - 115% of the highest operator established emergency transformer rating.
- 10.1 Set load-responsive transformer fault protection relays, if used, such that the protection settings do not expose the transformer to a fault level and duration that exceeds the transformer's mechanical withstand capability<sup>2</sup>.
11. For transformer overload protection relays that do not comply with the loadability component of Requirement R1, criterion 10 set the relays according to one of the following:
  - Set the relays to allow the transformer to be operated at an overload level of at least 150% of the maximum applicable nameplate rating, or 115% of the highest operator established emergency transformer rating, whichever is greater, for at least 15 minutes to provide time for the operator to take controlled action to relieve the overload.
  - Install supervision for the relays using either a top oil or simulated winding hot spot temperature element set no less than 100° C for the top oil temperature or no less than 140° C for the winding hot spot temperature<sup>3</sup>.
12. When the desired transmission line capability is limited by the requirement to adequately protect the transmission line, set the transmission line distance relays to a maximum of 125% of the apparent impedance (at the impedance angle of the transmission line) subject to the following constraints:
  - a. Set the maximum torque angle (MTA) to 90 degrees or the highest supported by the manufacturer.
  - b. Evaluate the relay loadability in amperes at the relay trip point at 0.85 per unit voltage and a power factor angle of 30 degrees.
  - c. Include a relay setting component of 87% of the current calculated in Requirement R1, criterion 12 in the Facility Rating determination for the circuit.

---

<sup>2</sup> As illustrated by the “dotted line” in IEEE C57.109-1993 - *IEEE Guide for Liquid-Immersed Transformer Through-Fault-Current Duration*, Clause 4.4, Figure 4.

<sup>3</sup> IEEE standard C57.91, Tables 7 and 8, specify that transformers are to be designed to withstand a winding hot spot temperature of 180 degrees C, and Annex A cautions that bubble formation may occur above 140 degrees C.



13. Where other situations present practical limitations on circuit capability, set the phase protection relays so they do not operate at or below 115% of such limitations.
- R2.** Each Transmission Owner, Generator Owner, and Distribution Provider shall set its out-of-step blocking elements to allow tripping of phase protective relays for faults that occur during the loading conditions used to verify transmission line relay loadability per Requirement R1. *[Violation Risk Factor: High] [Time Horizon: Long Term Planning]*
- R3.** Each Transmission Owner, Generator Owner, and Distribution Provider that uses a circuit capability with the practical limitations described in Requirement R1, criterion 7, 8, 9, 12, or 13 shall use the calculated circuit capability as the Facility Rating of the circuit and shall obtain the agreement of the Planning Coordinator, Transmission Operator, and Reliability Coordinator with the calculated circuit capability. *[Violation Risk Factor: Medium] [Time Horizon: Long Term Planning]*
- R4.** Each Transmission Owner, Generator Owner, and Distribution Provider that chooses to use Requirement R1 criterion 2 as the basis for verifying transmission line relay loadability shall provide its Planning Coordinator, Transmission Operator, and Reliability Coordinator with an updated list of circuits associated with those transmission line relays at least once each calendar year, with no more than 15 months between reports. *[Violation Risk Factor: Lower] [Time Horizon: Long Term Planning]*
- R5.** Each Transmission Owner, Generator Owner, and Distribution Provider that sets transmission line relays according to Requirement R1 criterion 12 shall provide an updated list of the circuits associated with those relays to its Regional Entity at least once each calendar year, with no more than 15 months between reports, to allow the ERO to compile a list of all circuits that have protective relay settings that limit circuit capability. *[Violation Risk Factor: Lower] [Time Horizon: Long Term Planning]*
- R6.** Each Planning Coordinator shall conduct an assessment at least once each calendar year, with no more than 15 months between assessments, by applying the criteria in PRC-023-~~45~~, Attachment B to determine the circuits in its Planning Coordinator area for which Transmission Owners, Generator Owners, and Distribution Providers must comply with Requirements R1 through R5. The Planning Coordinator shall: *[Violation Risk Factor: High] [Time Horizon: Long Term Planning]*
- 6.1** Maintain a list of circuits subject to PRC-023-~~45~~ per application of Attachment B, including identification of the first calendar year in which any criterion in PRC-023-~~45~~, Attachment B applies.
- 6.2** Provide the list of circuits to all Regional Entities, Reliability Coordinators, Transmission Owners, Generator Owners, and Distribution Providers within its Planning Coordinator area within 30 calendar days of the establishment of the initial list and within 30 calendar days of any changes to that list.

### C. Measures

- M1.** Each Transmission Owner, Generator Owner, and Distribution Provider shall have evidence such as spreadsheets or summaries of calculations to show that each of its transmission relays is set according to one of the criteria in Requirement R1, criterion 1 through 13 and shall have evidence such as coordination curves or summaries of calculations that show that relays set per criterion 10 do not expose the transformer to fault levels and durations beyond those indicated in the standard. (R1)

- M2.** Each Transmission Owner, Generator Owner, and Distribution Provider shall have evidence such as spreadsheets or summaries of calculations to show that each of its out-of-step blocking elements is set to allow tripping of phase protective relays for faults that occur during the loading conditions used to verify transmission line relay loadability per Requirement R1. (R2)
- M3.** Each Transmission Owner, Generator Owner, and Distribution Provider with transmission relays set according to Requirement R1, criterion 7, 8, 9, 12, or 13 shall have evidence such as Facility Rating spreadsheets or Facility Rating database to show that it used the calculated circuit capability as the Facility Rating of the circuit and evidence such as dated correspondence that the resulting Facility Rating was agreed to by its associated Planning Coordinator, Transmission Operator, and Reliability Coordinator. (R3)
- M4.** Each Transmission Owner, Generator Owner, or Distribution Provider that sets transmission line relays according to Requirement R1, criterion 2 shall have evidence such as dated correspondence to show that it provided its Planning Coordinator, Transmission Operator, and Reliability Coordinator with an updated list of circuits associated with those transmission line relays within the required timeframe. The updated list may either be a full list, a list of incremental changes to the previous list, or a statement that there are no changes to the previous list. (R4)
- M5.** Each Transmission Owner, Generator Owner, or Distribution Provider that sets transmission line relays according to Requirement R1, criterion 12 shall have evidence such as dated correspondence that it provided an updated list of the circuits associated with those relays to its Regional Entity within the required timeframe. The updated list may either be a full list, a list of incremental changes to the previous list, or a statement that there are no changes to the previous list. (R5)
- M6.** Each Planning Coordinator shall have evidence such as power flow results, calculation summaries, or study reports that it used the criteria established within PRC-023-~~45~~, Attachment B to determine the circuits in its Planning Coordinator area for which applicable entities must comply with the standard as described in Requirement R6. The Planning Coordinator shall have a dated list of such circuits and shall have evidence such as dated correspondence that it provided the list to the Regional Entities, Reliability Coordinators, Transmission Owners, Generator Owners, and Distribution Providers within its Planning Coordinator area within the required timeframe. (R6)

## **D. Compliance**

### **1. Compliance Monitoring Process**

#### **1.1. Compliance Enforcement Authority**

As defined in the NERC Rules of Procedure, “Compliance Enforcement Authority” means NERC or the Regional Entity in their respective roles of monitoring and enforcing compliance with the NERC Reliability Standards.

#### **1.2. Data Retention**

The Transmission Owner, Generator Owner, Distribution Provider and Planning Coordinator shall keep data or evidence to show compliance as identified below unless directed by its Compliance Enforcement Authority to retain specific evidence for a longer period of time as part of an investigation:

The Transmission Owner, Generator Owner, and Distribution Provider shall each retain documentation to demonstrate compliance with Requirements R1 through R5 for three calendar years.

The Planning Coordinator shall retain documentation of the most recent review process required in Requirement R6. The Planning Coordinator shall retain the most recent list of circuits in its Planning Coordinator area for which applicable entities must comply with the standard, as determined per Requirement R6.

If a Transmission Owner, Generator Owner, Distribution Provider, or Planning Coordinator is found non-compliant, it shall keep information related to the non-compliance until found compliant or for the time specified above, whichever is longer.

The Compliance Enforcement Authority shall keep the last audit record and all requested and submitted subsequent audit records.

### **1.3. Compliance Monitoring and Assessment Processes**

- Compliance Audit
- Self-Certification
- Spot Checking
- Compliance Violation Investigation
- Self-Reporting
- Complaint

### **1.4. Additional Compliance Information**

None.

**Violation Severity Levels:**

Requirement	Lower	Moderate	High	Severe
<b>R1</b>	N/A	N/A	N/A	<p>The responsible entity did not use any one of the following criteria (Requirement R1 criterion 1 through 13) for any specific circuit terminal to prevent its phase protective relay settings from limiting transmission system loadability while maintaining reliable protection of the BES for all fault conditions.</p> <p>OR</p> <p>The responsible entity did not evaluate relay loadability at 0.85 per unit voltage and a power factor angle of 30 degrees.</p>
<b>R2</b>	N/A	N/A	N/A	<p>The responsible entity failed to ensure that its out-of-step blocking elements allowed tripping of phase protective relays for faults that occur during the loading conditions used to verify transmission line relay loadability per Requirement R1.</p>
<b>R3</b>	N/A	N/A	N/A	<p>The responsible entity that uses a circuit capability with the practical limitations described in Requirement R1 criterion 7, 8, 9, 12, or 13 did not use the calculated circuit capability as the Facility Rating of the circuit.</p>

Standard PRC-023-54 — Transmission Relay Loadability

Requirement	Lower	Moderate	High	Severe
				OR The responsible entity did not obtain the agreement of the Planning Coordinator, Transmission Operator, and Reliability Coordinator with the calculated circuit capability.
<b>R4</b>	N/A	N/A	N/A	The responsible entity did not provide its Planning Coordinator, Transmission Operator, and Reliability Coordinator with an updated list of circuits that have transmission line relays set according to the criteria established in Requirement R1 criterion 2 at least once each calendar year, with no more than 15 months between reports.
<b>R5</b>	N/A	N/A	N/A	The responsible entity did not provide its Regional Entity, with an updated list of circuits that have transmission line relays set according to the criteria established in Requirement R1 criterion 12 at least once each calendar year, with no more than 15 months between reports.
<b>R6</b>	N/A	The Planning Coordinator used the criteria established within Attachment B to determine the circuits in its Planning Coordinator area for which applicable entities must comply with the standard and met parts 6.1 and 6.2, but more	The Planning Coordinator used the criteria established within Attachment B to determine the circuits in its Planning Coordinator area for which applicable entities must comply with the standard and met parts 6.1 and 6.2, but 24	The Planning Coordinator failed to use the criteria established within Attachment B to determine the circuits in its Planning Coordinator area for which applicable entities must comply with the standard.

Requirement	Lower	Moderate	High	Severe
		<p>than 15 months and less than 24 months lapsed between assessments.</p> <p>OR</p> <p>The Planning Coordinator used the criteria established within Attachment B at least once each calendar year, with no more than 15 months between assessments to determine the circuits in its Planning Coordinator area for which applicable entities must comply with the standard and met 6.1 and 6.2 but failed to include the calendar year in which any criterion in Attachment B first applies.</p> <p>OR</p> <p>The Planning Coordinator used the criteria established within Attachment B at least once each calendar year, with no more than 15 months between assessments to determine the circuits in its Planning Coordinator area for which applicable entities must comply with the standard and met 6.1 and 6.2 but provided the list of circuits to the Reliability Coordinators, Transmission Owners, Generator Owners, and Distribution Providers within its Planning Coordinator area between 31 days and 45 days after</p>	<p>months or more lapsed between assessments.</p> <p>OR</p> <p>The Planning Coordinator used the criteria established within Attachment B at least once each calendar year, with no more than 15 months between assessments to determine the circuits in its Planning Coordinator area for which applicable entities must comply with the standard and met 6.1 and 6.2 but provided the list of circuits to the Reliability Coordinators, Transmission Owners, Generator Owners, and Distribution Providers within its Planning Coordinator area between 46 days and 60 days after list was established or updated. (part 6.2)</p>	<p>OR</p> <p>The Planning Coordinator used the criteria established within Attachment B, at least once each calendar year, with no more than 15 months between assessments to determine the circuits in its Planning Coordinator area for which applicable entities must comply with the standard but failed to meet parts 6.1 and 6.2.</p> <p>OR</p> <p>The Planning Coordinator used the criteria established within Attachment B at least once each calendar year, with no more than 15 months between assessments to determine the circuits in its Planning Coordinator area for which applicable entities must comply with the standard but failed to maintain the list of circuits determined according to the process described in Requirement R6. (part 6.1)</p> <p>OR</p> <p>The Planning Coordinator used the criteria established within Attachment B at least once each calendar year, with no more than 15 months between assessments to determine the circuits in its Planning Coordinator area for which applicable entities must comply with the standard and met</p>

Standard PRC-023-54 — Transmission Relay Loadability

Requirement	Lower	Moderate	High	Severe
		<p>the list was established or updated. (part 6.2)</p>		<p>6.1 but failed to provide the list of circuits to the Reliability Coordinators, Transmission Owners, Generator Owners, and Distribution Providers within its Planning Coordinator area or provided the list more than 60 days after the list was established or updated. (part 6.2)</p> <p>OR</p> <p>The Planning Coordinator failed to determine the circuits in its Planning Coordinator area for which applicable entities must comply with the standard.</p>

**E. Regional Differences**

None.

**F. Supplemental Technical Reference Document**

- The following document is an explanatory supplement to the standard. It provides the technical rationale underlying the requirements in this standard. The reference document contains methodology examples for illustration purposes it does not preclude other technically comparable methodologies.

“Determination and Application of Practical Relaying Loadability Ratings,” Version 1.0, June 2008, prepared by the System Protection and Control Task Force of the NERC Planning Committee, available at:

[http://www.nerc.com/fileUploads/File/Standards/Relay\\_Loadability\\_Reference\\_Doc\\_Clean\\_Final\\_2008July3.pdf](http://www.nerc.com/fileUploads/File/Standards/Relay_Loadability_Reference_Doc_Clean_Final_2008July3.pdf)

**Version History**

Version	Date	Action	Change Tracking
1	February 12, 2008	Approved by Board of Trustees	New
1	March 19, 2008	Corrected typo in last sentence of Severe VSL for Requirement 3 — “then” should be “than.”	Errata
1	March 18, 2010	Approved by FERC	
1	Filed for approval April 19, 2010	Changed VRF for R3 from Medium to High; changed VSLs for R1, R2, R3 to binary Severe to comply with Order 733	Revision
2	March 10, 2011 approved by Board of Trustees	Revised to address initial set of directives from Order 733	Revision (Project 2010-13)
2	March 15, 2012	FERC order issued approving PRC-023-2 (approval becomes effective May 7, 2012)	
3	November 7, 2013	Adopted by NERC Board of Trustees	Supplemental SAR to Clarify applicability for consistency with PRC-025-1 and other minor corrections.



Version	Date	Action	Change Tracking
4	November 13, 2014	Adopted by the NERC Board of Trustees	Replaced references to Special Protection System and SPS with Remedial Action Scheme and RAS
4	November 19, 2015	FERC Order issued approving PRC-023-4. Docket No. RM15-13-000.	
5	May 13, 2021	Adopted by the NERC Board of Trustees	Revisions under Project 2015-09

**PRC-023-~~45~~ — Attachment A**

1. This standard includes any protective functions which could trip with or without time delay, on load current, including but not limited to:
  - 1.1. Phase distance.
  - 1.2. Out-of-step tripping.
  - 1.3. Switch-on-to-fault.
  - 1.4. Overcurrent relays.
  - 1.5. Communications aided protection schemes including but not limited to:
    - 1.5.1 Permissive overreach transfer trip (POTT).
    - 1.5.2 Permissive under-reach transfer trip (PUTT).
    - 1.5.3 Directional comparison blocking (DCB).
    - 1.5.4 Directional comparison unblocking (DCUB).
  - 1.6. Phase overcurrent supervisory elements (i.e., phase fault detectors) associated with current-based, communication-assisted schemes (i.e., pilot wire, phase comparison, and line current differential) where the scheme is capable of tripping for loss of communications.
2. The following protection systems are excluded from requirements of this standard:
  - 2.1. Relay elements that are only enabled when other relays or associated systems fail. For example:
    - Overcurrent elements that are only enabled during loss of potential conditions.
    - Elements that are only enabled during a loss of communications except as noted in section 1.6.
  - 2.2. Protection systems intended for the detection of ground fault conditions.
  - 2.3. Protection systems intended for protection during stable power swings.
  - 2.4. Not used.
  - 2.5. Relay elements used only for Remedial Action Schemes applied and approved in accordance with NERC Reliability Standards PRC-012 through PRC-017 or their successors.
  - 2.6. Protection systems that are designed only to respond in time periods which allow 15 minutes or greater to respond to overload conditions.
  - 2.7. Thermal emulation relays which are used in conjunction with dynamic Facility Ratings.
  - 2.8. Relay elements associated with dc lines.
  - 2.9. Relay elements associated with dc converter transformers.

PRC-023-~~45~~ — Attachment B

**Circuits to Evaluate**

- Transmission lines operated at 100 kV to 200 kV and transformers with low voltage terminals connected at 100 kV to 200 kV.
- Transmission lines operated below 100 kV and transformers with low voltage terminals connected below 100 kV that are part of the Bulk Electric System.

**Criteria**

If any of the following criteria apply to a circuit, the applicable entity must comply with the standard for that circuit.

**B1.** The circuit is a monitored Facility of a permanent flowgate in the Eastern Interconnection, a major transfer path within the Western Interconnection as defined by the Regional Entity, or a comparable monitored Facility in the Québec Interconnection, that has been included to address reliability concerns for loading of that circuit, as confirmed by the applicable Planning Coordinator.

**B2.** The circuit is selected by the Planning Coordinator or Transmission Planner based on Planning Assessments of the Near-Term Transmission Planning Horizon that identify instances of instability, Cascading, or uncontrolled separation, that adversely impact the reliability of the Bulk Electric System for planning events.

~~**B2.** The circuit is a monitored Facility of an Interconnection Reliability Operating Limit (IROL), where the IROL was determined in the planning horizon pursuant to FAC-010.~~

**B3.** The circuit forms a path (as agreed to by the Generator Operator and the transmission entity) to supply off-site power to a nuclear plant as established in the Nuclear Plant Interface Requirements (NPIRs) pursuant to NUC-001.

**B4.** The circuit is identified through the following sequence of power flow analyses<sup>4</sup> performed by the Planning Coordinator for the one-to-five-year planning horizon:

- a. Simulate double contingency combinations selected by engineering judgment, without manual system adjustments in between the two contingencies (reflects a situation where a System Operator may not have time between the two contingencies to make appropriate system adjustments).
- b. For circuits operated between 100 kV and 200 kV evaluate the post-contingency loading, in consultation with the Facility owner, against a threshold based on the Facility Rating assigned for that circuit and used in the power flow case by the Planning Coordinator.

---

<sup>4</sup> Past analyses may be used to support the assessment if no material changes to the system have occurred since the last assessment

- c. When more than one Facility Rating for that circuit is available in the power flow case, the threshold for selection will be based on the Facility Rating for the loading duration nearest four hours.
  - d. The threshold for selection of the circuit will vary based on the loading duration assumed in the development of the Facility Rating.
    - i. If the Facility Rating is based on a loading duration of up to and including four hours, the circuit must comply with the standard if the loading exceeds 115% of the Facility Rating.
    - ii. If the Facility Rating is based on a loading duration greater than four and up to and including eight hours, the circuit must comply with the standard if the loading exceeds 120% of the Facility Rating.
    - iii. If the Facility Rating is based on a loading duration of greater than eight hours, the circuit must comply with the standard if the loading exceeds 130% of the Facility Rating.
  - e. Radially operated circuits serving only load are excluded.
- B5.** The circuit is selected by the Planning Coordinator based on technical studies or assessments, other than those specified in criteria B1 through B4, in consultation with the Facility owner.
- B6.** The circuit is mutually agreed upon for inclusion by the Planning Coordinator and the Facility owner.

Exhibit A-8

PRC-026-2 (Clean and Redline to Last Approved)

## A. Introduction

1. **Title:** Relay Performance During Stable Power Swings
2. **Number:** PRC-026-2
3. **Purpose:** To ensure that load-responsive protective relays are expected to not trip in response to stable power swings during non-Fault conditions.
4. **Applicability:**
  - 4.1. **Functional Entities:**
    - 4.1.1 Generator Owner that applies load-responsive protective relays as described in PRC-026-2 – Attachment A at the terminals of the Elements listed in Section 4.2, Facilities.
    - 4.1.2 Planning Coordinator.
    - 4.1.3 Transmission Owner that applies load-responsive protective relays as described in PRC-026-2 – Attachment A at the terminals of the Elements listed in Section 4.2, Facilities.
  - 4.2. **Facilities:** The following Elements that are part of the Bulk Electric System (BES):
    - 4.2.1 Generators.
    - 4.2.2 Transformers.
    - 4.2.3 Transmission lines.
5. **Background:**

This is the third phase of a three-phased standard development project that focused on developing this new Reliability Standard to address protective relay operations due to stable power swings. The March 18, 2010, Federal Energy Regulatory Commission (FERC) Order No. 733 approved Reliability Standard PRC-023-1 – Transmission Relay Loadability. In that Order, FERC directed NERC to address three areas of relay loadability that include modifications to the approved PRC-023-1, development of a new Reliability Standard to address generator protective relay loadability, and a new Reliability Standard to address the operation of protective relays due to stable power swings. This project's SAR addresses these directives with a three-phased approach to standard development.

Phase 1 focused on making the specific modifications from FERC Order No. 733 to PRC-023-1. Reliability Standard PRC-023-2, which incorporated these modifications, became mandatory on July 1, 2012.

Phase 2 focused on developing a new Reliability Standard, PRC-025-1 – Generator Relay Loadability, to address generator protective relay loadability. PRC-025-1 became mandatory on October 1, 2014, along with PRC-023-3, which was modified to harmonize PRC-023-2 with PRC-025-1.

Phase 3 focuses on preventing protective relays from tripping unnecessarily due to stable power swings by requiring identification of Elements on which a stable or unstable power swing may affect Protection System operation, assessment of the security of load-

responsive protective relays to tripping in response to only a stable power swing, and implementation of Corrective Action Plans (CAP), where necessary. Phase 3 improves security of load-responsive protective relays for stable power swings so they are expected to not trip in response to stable power swings during non-Fault conditions while maintaining dependable fault detection and dependable out-of-step tripping.

**6. Effective Dates: See Implementation Plan**

## B. Requirements and Measures

**R1.** Each Planning Coordinator shall, at least once each calendar year, provide notification of each generator, transformer, and transmission line BES Element in its area that meets one or more of the following criteria, if any, to the respective Generator Owner and Transmission Owner: *[Violation Risk Factor: Medium] [Time Horizon: Long-term Planning]*

Criteria:

1. Generator(s) where an angular stability constraint, identified in Planning Assessments of the Near-Term Transmission Planning Horizon for a planning event, that is addressed by limiting the output of a generator or a Remedial Action Scheme (RAS), and those Elements terminating at the Transmission station associated with the generator(s).
  2. Elements associated with angular instability identified in Planning Assessments of the Near-Term Transmission Planning Horizon for a planning event..
  3. An Element that forms the boundary of an island in the most recent underfrequency load shedding (UFLS) design assessment based on application of the Planning Coordinator’s criteria for identifying islands, only if the island is formed by tripping the Element due to angular instability.
  4. An Element identified in the most recent annual Planning Assessment of the Near-Term Transmission Planning Horizon where relay tripping occurs due to a stable or unstable<sup>1</sup> power swing during a simulated disturbance for a planning event.
- M1.** Each Planning Coordinator shall have dated evidence that demonstrates notification of the generator, transformer, and transmission line BES Element(s) that meet one or more of the criteria in Requirement R1, if any, to the respective Generator Owner and Transmission Owner. Evidence may include, but is not limited to, the following documentation: emails, facsimiles, records, reports, transmittals, lists, or spreadsheets.

---

<sup>1</sup> An example of an unstable power swing is provided in the Guidelines and Technical Basis section, “Justification for Including Unstable Power Swings in the Requirements section of the Guidelines and Technical Basis.”



- R2.** Each Generator Owner and Transmission Owner shall: [Violation Risk Factor: High] [Time Horizon: Operations Planning]
- 2.1** Within 12 full calendar months of notification of a BES Element pursuant to Requirement R1, determine whether its load-responsive protective relay(s) applied to that BES Element meets the criteria in PRC-026-2 – Attachment B where an evaluation of that Element’s load-responsive protective relay(s) based on PRC-026-2 – Attachment B criteria has not been performed in the last five calendar years.
- 2.2** Within 12 full calendar months of becoming aware<sup>2</sup> of a generator, transformer, or transmission line BES Element that tripped in response to a stable or unstable<sup>3</sup> power swing due to the operation of its protective relay(s), determine whether its load-responsive protective relay(s) applied to that BES Element meets the criteria in PRC-026-2 – Attachment B.
- M2.** Each Generator Owner and Transmission Owner shall have dated evidence that demonstrates the evaluation was performed according to Requirement R2. Evidence may include, but is not limited to, the following documentation: apparent impedance characteristic plots, email, design drawings, facsimiles, R-X plots, software output, records, reports, transmittals, lists, settings sheets, or spreadsheets.
- R3.** Each Generator Owner and Transmission Owner shall, within six full calendar months of determining a load-responsive protective relay does not meet the PRC-026-2 – Attachment B criteria pursuant to Requirement R2, develop a Corrective Action Plan (CAP) to meet one of the following: [*Violation Risk Factor: Medium*] [*Time Horizon: Operations Planning*]
- The Protection System meets the PRC-026-2 – Attachment B criteria, while maintaining dependable fault detection and dependable out-of-step tripping (if out-of-step tripping is applied at the terminal of the BES Element); or
  - The Protection System is excluded under the PRC-026-2 – Attachment A criteria (e.g., modifying the Protection System so that relay functions are supervised by power swing blocking or using relay systems that are immune to power swings), while maintaining dependable fault detection and dependable out-of-step tripping (if out-of-step tripping is applied at the terminal of the BES Element).
- M3.** The Generator Owner and Transmission Owner shall have dated evidence that demonstrates the development of a CAP in accordance with Requirement R3. Evidence may include, but is not limited to, the following documentation: corrective action plans, maintenance records, settings sheets, project or work management program records, or work orders.
- R4.** Each Generator Owner and Transmission Owner shall implement each CAP developed pursuant to Requirement R3 and update each CAP if actions or timetables change until all actions are complete. [*Violation Risk Factor: Medium*][*Time Horizon: Long-Term Planning*]

- M4.** The Generator Owner and Transmission Owner shall have dated evidence that demonstrates implementation of each CAP according to Requirement R4, including updates to the CAP when actions or timetables change. Evidence may include, but is not limited to, the following documentation: corrective action plans, maintenance records, settings sheets, project or work management program records, or work orders.

## C. Compliance

### 1. Compliance Monitoring Process

#### 1.1. Compliance Enforcement Authority

As defined in the NERC Rules of Procedure, “Compliance Enforcement Authority” (CEA) means NERC or the Regional Entity in their respective roles of monitoring and enforcing compliance with the NERC Reliability Standards.

#### 1.2. Evidence Retention

The following evidence retention periods identify the period of time an entity is required to retain specific evidence to demonstrate compliance. For instances where the evidence retention period specified below is shorter than the time since the last audit, the CEA may ask an entity to provide other evidence to show that it was compliant for the full time period since the last audit.

The Generator Owner, Planning Coordinator, and Transmission Owner shall keep data or evidence to show compliance as identified below unless directed by its CEA to retain specific evidence for a longer period of time as part of an investigation.

- The Planning Coordinator shall retain evidence of Requirement R1 for a minimum of one calendar year following the completion of the Requirement.
- The Generator Owner and Transmission Owner shall retain evidence of Requirement R2 evaluation for a minimum of 12 calendar months following completion of each evaluation where a CAP is not developed.
- The Generator Owner and Transmission Owner shall retain evidence of Requirements R2, R3, and R4 for a minimum of 12 calendar months following completion of each CAP.

If a Generator Owner, Planning Coordinator, or Transmission Owner is found non-compliant, it shall keep information related to the non-compliance until mitigation is complete and approved, or for the time specified above, whichever is longer.

The CEA shall keep the last audit records and all requested and submitted subsequent audit records.

---

<sup>2</sup> Some examples of the ways an entity may become aware of a power swing are provided in the Guidelines and Technical Basis section, “Becoming Aware of an Element That Tripped in Response to a Power Swing.”

<sup>3</sup> An example of an unstable power swing is provided in the Guidelines and Technical Basis section, “Justification for Including Unstable Power Swings in the Requirements section of the Guidelines and Technical Basis.”

**1.3. Compliance Monitoring and Assessment Processes:**

As defined in the NERC Rules of Procedure; “Compliance Monitoring and Assessment Processes” refers to the identification of the processes that will be used to evaluate data or information for the purpose of assessing performance or outcomes with the associated reliability standard.

**1.4. Additional Compliance Information**

None.

Table of Compliance Elements

R#	Time Horizon	VRF	Violation Severity Levels			
			Lower VSL	Moderate VSL	High VSL	Severe VSL
R1	Long-term Planning	Medium	The Planning Coordinator provided notification of the BES Element(s) in accordance with Requirement R1, but was less than or equal to 30 calendar days late.	The Planning Coordinator provided notification of the BES Element(s) in accordance with Requirement R1, but was more than 30 calendar days and less than or equal to 60 calendar days late.	The Planning Coordinator provided notification of the BES Element(s) in accordance with Requirement R1, but was more than 60 calendar days and less than or equal to 90 calendar days late.	The Planning Coordinator provided notification of the BES Element(s) in accordance with Requirement R1, but was more than 90 calendar days late.  OR  The Planning Coordinator failed to provide notification of the BES Element(s) in accordance with Requirement R1.

R#	Time Horizon	VRF	Violation Severity Levels			
			Lower VSL	Moderate VSL	High VSL	Severe VSL
<b>R2</b>	Operations Planning	High	The Generator Owner or Transmission Owner evaluated its load-responsive protective relay(s) in accordance with Requirement R2, but was less than or equal to 30 calendar days late.	The Generator Owner or Transmission Owner evaluated its load-responsive protective relay(s) in accordance with Requirement R2, but was more than 30 calendar days and less than or equal to 60 calendar days late.	The Generator Owner or Transmission Owner evaluated its load-responsive protective relay(s) in accordance with Requirement R2, but was more than 60 calendar days and less than or equal to 90 calendar days late.	The Generator Owner or Transmission Owner evaluated its load-responsive protective relay(s) in accordance with Requirement R2, but was more than 90 calendar days late.  OR The Generator Owner or Transmission Owner failed to evaluate its load-responsive protective relay(s) in accordance with Requirement R2.

R#	Time Horizon	VRF	Violation Severity Levels			
			Lower VSL	Moderate VSL	High VSL	Severe VSL
<b>R3</b>	Long-term Planning	Medium	The Generator Owner or Transmission Owner developed a Corrective Action Plan (CAP) in accordance with Requirement R3, but in more than six calendar months and less than or equal to seven calendar months.	The Generator Owner or Transmission Owner developed a Corrective Action Plan (CAP) in accordance with Requirement R3, but in more than seven calendar months and less than or equal to eight calendar months.	The Generator Owner or Transmission Owner developed a Corrective Action Plan (CAP) in accordance with Requirement R3, but in more than eight calendar months and less than or equal to nine calendar months.	The Generator Owner or Transmission Owner developed a Corrective Action Plan (CAP) in accordance with Requirement R3, but in more than nine calendar months.  OR The Generator Owner or Transmission Owner failed to develop a CAP in accordance with Requirement R3.
<b>R4</b>	Long-term Planning	Medium	The Generator Owner or Transmission Owner implemented a Corrective Action Plan (CAP), but failed to update a CAP when actions or timetables changed, in accordance with Requirement R4.	N/A	N/A	The Generator Owner or Transmission Owner failed to implement a Corrective Action Plan (CAP) in accordance with Requirement R4.

#### D. Regional Variances

None.

#### E. Interpretations

None.

#### F. Associated Documents

*Applied Protective Relaying*, Westinghouse Electric Corporation, 1979.

Burdy, John, *Loss-of-excitation Protection for Synchronous Generators GER-3183*, General Electric Company.

IEEE Power System Relaying Committee WG D6, *Power Swing and Out-of-Step Considerations on Transmission Lines*, July 2005: <http://www.pes-psrc.org/Reports/Power%20Swing%20and%20OOS%20Considerations%20on%20Transmission%20Lines%20F..pdf>.

Kimbark Edward Wilson, *Power System Stability, Volume II: Power Circuit Breakers and Protective Relays*, Published by John Wiley and Sons, 1950.

Kundur, Prabha, *Power System Stability and Control*, 1994, Palo Alto: EPRI, McGraw Hill, Inc.

NERC System Protection and Control Subcommittee, *Protection System Response to Power Swings*, August 2013: [http://www.nerc.com/comm/PC/System%20Protection%20and%20Control%20Subcommittee%20SPCS%2020/SPCS%20Power%20Swing%20Report\\_Final\\_20131015.pdf](http://www.nerc.com/comm/PC/System%20Protection%20and%20Control%20Subcommittee%20SPCS%2020/SPCS%20Power%20Swing%20Report_Final_20131015.pdf).

Reimert, Donald, *Protective Relaying for Power Generation Systems*, 2006, Boca Raton: CRC Press.

#### Version History

Version	Date	Action	Change Tracking
1	November 13, 2014	Adopted by NERC Board of Trustees	New
1	March 17, 2016	FERC Order issued approving PRC-026-1. Docket No. RM15-8-000.	

Version	Date	Action	Change Tracking
2	May 13, 2021	Adopted by NERC Board of Trustees	Revised under Project 2015-09



### PRC-026-2 – Attachment A

This standard applies to any protective functions which could trip instantaneously or with a time delay of less than 15 cycles on load current (i.e., “load-responsive”) including, but not limited to:

- Phase distance
- Phase overcurrent
- Out-of-step tripping
- Loss-of-field

The following protection functions are excluded from Requirements of this standard:

- Relay elements supervised by power swing blocking
- Relay elements that are only enabled when other relays or associated systems fail. For example:
  - Overcurrent elements that are only enabled during loss of potential conditions.
  - Relay elements that are only enabled during a loss of communications
- Thermal emulation relays which are used in conjunction with dynamic Facility Ratings
- Relay elements associated with direct current (dc) lines
- Relay elements associated with dc converter transformers
- Phase fault detector relay elements employed to supervise other load-responsive phase distance elements (i.e., in order to prevent false operation in the event of a loss of potential)
- Relay elements associated with switch-onto-fault schemes
- Reverse power relay on the generator
- Generator relay elements that are armed only when the generator is disconnected from the system, (e.g., non-directional overcurrent elements used in conjunction with inadvertent energization schemes, and open breaker flashover schemes)
- Current differential relay, pilot wire relay, and phase comparison relay
- Voltage-restrained or voltage-controlled overcurrent relays

## PRC-026-2 – Attachment B

### Criterion A:

An impedance-based relay used for tripping is expected to not trip for a stable power swing, when the relay characteristic is completely contained within the unstable power swing region.<sup>4</sup> The unstable power swing region is formed by the union of three shapes in the impedance (R-X) plane; (1) a lower loss-of-synchronism circle based on a ratio of the sending-end to receiving-end voltages of 0.7; (2) an upper loss-of-synchronism circle based on a ratio of the sending-end to receiving-end voltages of 1.43; (3) a lens that connects the endpoints of the total system impedance (with the parallel transfer impedance removed) bounded by varying the sending-end and receiving-end voltages from 0.0 to 1.0 per unit, while maintaining a constant system separation angle across the total system impedance where:

1. The system separation angle is:
  - At least 120 degrees, or
  - An angle less than 120 degrees where a documented transient stability analysis demonstrates that the expected maximum stable separation angle is less than 120 degrees.
2. All generation is in service and all transmission BES Elements are in their normal operating state when calculating the system impedance.
3. Saturated (transient or sub-transient) reactance is used for all machines.

---

<sup>4</sup> Guidelines and Technical Basis, Figures 1 and 2.

## PRC-026-2 – Attachment B

### Criterion B:

The pickup of an overcurrent relay element used for tripping, that is above the calculated current value (with the parallel transfer impedance removed) for the conditions below:

1. The system separation angle is:
  - At least 120 degrees, or
  - An angle less than 120 degrees where a documented transient stability analysis demonstrates that the expected maximum stable separation angle is less than 120 degrees.
2. All generation is in service and all transmission BES Elements are in their normal operating state when calculating the system impedance.
3. Saturated (transient or sub-transient) reactance is used for all machines.
4. Both the sending-end and receiving-end voltages at 1.05 per unit.

## Guidelines and Technical Basis

### Introduction

The NERC System Protection and Control Subcommittee technical document, *Protection System Response to Power Swings*, August 2013,<sup>5</sup> (“PSRPS Report” or “report”) was specifically prepared to support the development of this NERC Reliability Standard. The report provided a historical perspective on power swings as early as 1965 up through the approval of the report by the NERC Planning Committee. The report also addresses reliability issues regarding trade-offs between security and dependability of Protection Systems, considerations for this NERC Reliability Standard, and a collection of technical information about power swing characteristics and varying issues with practical applications and approaches to power swings. Of these topics, the report suggests an approach for this NERC Reliability Standard (“standard” or “PRC-026-2”) which is consistent with addressing three regulatory directives in the FERC Order No. 733. The first directive concerns the need for “...protective relay systems that differentiate between faults and stable power swings and, when necessary, phases out protective relay systems that cannot meet this requirement.”<sup>6</sup> Second, is “...to develop a Reliability Standard addressing undesirable relay operation due to stable power swings.”<sup>7</sup> The third directive “...to consider “islanding” strategies that achieve the fundamental performance for all islands in developing the new Reliability Standard addressing stable power swings”<sup>8</sup> was considered during development of the standard.

The development of this standard implements the majority of the approaches suggested by the report. However, it is noted that the Reliability Coordinator and Transmission Planner have not been included in the standard’s Applicability section (as suggested by the PSRPS Report). This is so that a single entity, the Planning Coordinator, may be the single source for identifying Elements according to Requirement R1. A single source will insure that multiple entities will not identify Elements in duplicate, nor will one entity fail to provide an Element because it believes the Element is being provided by another entity. The Planning Coordinator has, or has access to, the wide-area model and can correctly identify the Elements that may be susceptible to a stable or unstable power swing. Additionally, not including the Reliability Coordinator and Transmission Planner is consistent with the applicability of other relay loadability NERC Reliability Standards (e.g., PRC-023 and PRC-025). It is also consistent with the NERC Functional Model.

The phrase, “while maintaining dependable fault detection and dependable out-of-step tripping” in Requirement R3, describes that the Generator Owner and Transmission Owner are to comply with this standard while achieving its desired protection goals. Load-responsive protective relays, as addressed within this standard, may be intended to provide a variety of backup protection functions, both within the generating unit or generating plant and on the transmission system, and

---

<sup>5</sup> NERC System Protection and Control Subcommittee, *Protection System Response to Power Swings*, August 2013: [http://www.nerc.com/comm/PC/System%20Protection%20and%20Control%20Subcommittee%20SPCS%2020/SPCS%20Power%20Swing%20Report\\_Final\\_20131015.pdf](http://www.nerc.com/comm/PC/System%20Protection%20and%20Control%20Subcommittee%20SPCS%2020/SPCS%20Power%20Swing%20Report_Final_20131015.pdf)

<sup>6</sup> Transmission Relay Loadability Reliability Standard, Order No. 733, P.150 FERC ¶ 61,221 (2010).

<sup>7</sup> Ibid. P.153.

<sup>8</sup> Ibid. P.162.

this standard is not intended to result in the loss of these protection functions. Instead, the Generator Owner and Transmission Owner must consider both the Requirements within this standard and its desired protection goals and perform modifications to its protective relays or protection philosophies as necessary to achieve both.

## Power Swings

The IEEE Power System Relaying Committee WG D6 developed a technical document called *Power Swing and Out-of-Step Considerations on Transmission Lines* (July 2005) that provides background on power swings. The following are general definitions from that document:<sup>9</sup>

**Power Swing:** a variation in three phase power flow which occurs when the generator rotor angles are advancing or retarding relative to each other in response to changes in load magnitude and direction, line switching, loss of generation, faults, and other system disturbances.

**Pole Slip:** a condition whereby a generator, or group of generators, terminal voltage angles (or phases) go past 180 degrees with respect to the rest of the connected power system.

**Stable Power Swing:** a power swing is considered stable if the generators do not slip poles and the system reaches a new state of equilibrium, i.e. an acceptable operating condition.

**Unstable Power Swing:** a power swing that will result in a generator or group of generators experiencing pole slipping for which some corrective action must be taken.

**Out-of-Step Condition:** Same as an unstable power swing.

**Electrical System Center or Voltage Zero:** it is the point or points in the system where the voltage becomes zero during an unstable power swing.

## Burden to Entities

The PSRPS Report provides a technical basis and approach for focusing on Protection Systems, which are susceptible to power swings, while achieving the purpose of the standard. The approach reduces the number of relays to which the PRC-026-2 Requirements would apply by first identifying the BES Element(s) on which load-responsive protective relays must be evaluated. The first step uses criteria to identify the Elements on which a Protection System is expected to be challenged by power swings. Of those Elements, the second step is to evaluate each load-responsive protective relay that is applied on each identified Element. Rather than requiring the Planning Coordinator or Transmission Planner to perform simulations to obtain information for each identified Element, the Generator Owner and Transmission Owner will reduce the need for simulation by comparing the load-responsive protective relay characteristic to specific criteria in PRC-026-2 – Attachment B.

---

<sup>9</sup> <http://www.pes-psrc.org/Reports/Power%20Swing%20and%20OOS%20Considerations%20on%20Transmission%20Lines%20F..pdf>.

## Applicability

The standard is applicable to the Generator Owner, Planning Coordinator, and Transmission Owner entities. More specifically, the Generator Owner and Transmission Owner entities are applicable when applying load-responsive protective relays at the terminals of the applicable BES Elements. The standard is applicable to the following BES Elements: generators, transformers, and transmission lines. The Distribution Provider was considered for inclusion in the standard; however, it is not subject to the standard because this entity, by functional registration, would not own generators, transmission lines, or transformers other than load serving.

Load-responsive protective relays include any protective functions which could trip with or without time delay, on load current.

## Requirement R1

The Planning Coordinator has a wide-area view and is in the position to identify what, if any, Elements meet the criteria. The criterion-based approach is consistent with the NERC System Protection and Control Subcommittee (SPCS) technical document, *Protection System Response to Power Swings* (August 2013),<sup>10</sup> which recommends a focused approach to determine an at-risk Element. Identification of Elements comes from the annual Planning Assessments pursuant to the transmission planning (i.e., “TPL”) and other NERC Reliability Standards (e.g., PRC-006), and the standard is not requiring any other assessments to be performed by the Planning Coordinator. The required notification on a calendar year basis to the respective Generator Owner and Transmission Owner is sufficient because it is expected that the Planning Coordinator will make its notifications following the completion of its annual Planning Assessments. The Planning Coordinator will continue to provide notification of Elements on a calendar year basis even if a study is performed less frequently (e.g., PRC-006 – Automatic Underfrequency Load Shedding, which is five years) and has not changed. It is possible that a Planning Coordinator could utilize studies from a prior year in determining the necessary notifications pursuant to Requirement R1.

## Criterion 1

The first criterion involves generator(s) where an angular stability constraint exists that is addressed by limiting the output of a generator or a Remedial Action Scheme (RAS) and those Elements terminating at the Transmission station associated with the generator(s). For example, a scheme to remove generation for specific conditions is implemented for a four-unit generating plant (1,100 MW). Two of the units are 500 MW each; one is connected to the 345 kV system and one is connected to the 230 kV system. The Transmission Owner has two 230 kV transmission lines and one 345 kV transmission line all terminating at the generating facility as well as a 345/230 kV autotransformer. The remaining 100 MW consists of two 50 MW combustion turbine (CT) units connected to four 66 kV transmission lines. The 66 kV transmission lines are not electrically joined to the 345 kV and 230 kV transmission lines at the plant site and are not subject to any generating output limitation or RAS. A stability constraint limits the output of the portion of the

---

<sup>10</sup> [http://www.nerc.com/comm/PC/System%20Protection%20and%20Control%20Subcommittee%20SPCS%2020/SPCS%20Power%20Swing%20Report\\_Final\\_20131015.pdf](http://www.nerc.com/comm/PC/System%20Protection%20and%20Control%20Subcommittee%20SPCS%2020/SPCS%20Power%20Swing%20Report_Final_20131015.pdf)

plant affected by the RAS to 700 MW for an outage of the 345 kV transmission line. The RAS trips one of the 500 MW units to maintain stability for a loss of the 345 kV transmission line when the total output from both 500 MW units is above 700 MW. For this example, both 500 MW generating units and the associated generator step-up (GSU) transformers would be identified as Elements meeting this criterion. The 345/230 kV autotransformer, the 345 kV transmission line, and the two 230 kV transmission lines would also be identified as Elements meeting this criterion. The 50 MW combustion turbines and 66 kV transmission lines would not be identified pursuant to Criterion 1 because these Elements are not subject to any generating output limitation or RAS and do not terminate at the Transmission station associated with the generators that are subject to any generating output limitation or RAS.

### **Criterion 2**

The second criterion involves Elements associated with angular instability identified in the Planning Assessments. For example, if Planning Assessments have identified that an angular instability could limit transfer capability on two long parallel 500 kV transmission lines to a maximum of 1,200 MW, and this limitation is based on angular instability resulting from a fault and subsequent loss of one of the two lines, then both lines would be identified as Elements meeting the criterion.

### **Criterion 3**

The third criterion involves Elements that form the boundary of an island within an underfrequency load shedding (UFLS) design assessment. The criterion applies to islands identified based on application of the Planning Coordinator's criteria for identifying islands, where the island is formed by tripping the Elements based on angular instability. The criterion applies if the angular instability is modeled in the UFLS design assessment, or if the boundary is identified "off-line" (i.e., the Elements are selected based on angular instability considerations, but the Elements are tripped in the UFLS design assessment without modeling the initiating angular instability). In cases where an out-of-step condition is detected and tripping is initiated at an alternate location, the criterion applies to the Element on which the power swing is detected. The criterion does not apply to islands identified based on other considerations that do not involve angular instability, such as excessive loading, Planning Coordinator area boundary tie lines, or Balancing Authority boundary tie lines.

### **Criterion 4**

The fourth criterion involves Elements identified in the most recent annual Planning Assessment where relay tripping occurs due to a stable or unstable<sup>11</sup> power swing during a simulated disturbance. The intent is for the Planning Coordinator to include any Element(s) where relay tripping was observed during simulations performed for the most recent annual Planning Assessment associated with the transmission planning TPL-001-4 Reliability Standard. Note that

---

<sup>11</sup> Refer to the "Justification for Including Unstable Power Swings in the Requirements" section.

relay tripping must be assessed within those annual Planning Assessments per TPL-001-4, R4, Part 4.3.1.3, which indicates that analysis shall include the “Tripping of Transmission lines and transformers where transient swings cause Protection System operation based on generic or actual relay models.” Identifying such Elements according to Criterion 4 and notifying the respective Generator Owner and Transmission Owner will require that the owners of any load-responsive protective relay applied at the terminals of the identified Element evaluate the relay’s susceptibility to tripping in response to a stable power swing.

Planning Coordinators have the discretion to determine whether the observed tripping for a power swing in its Planning Assessments occurs for valid contingencies and system conditions. The Planning Coordinator will address tripping that is observed in transient analyses on an individual basis; therefore, the Planning Coordinator is responsible for identifying the Elements based only on simulation results that are determined to be valid.

Due to the nature of how a Planning Assessment is performed, there may be cases where a previously-identified Element is not identified in the most recent annual Planning Assessment. If so, this is acceptable because the Generator Owner and Transmission Owner would have taken action upon the initial notification of the previously identified Element. When an Element is not identified in later Planning Assessments, the risk of load-responsive protective relays tripping in response to a stable power swing during non-Fault conditions would have already been assessed under Requirement R2 and mitigated according to Requirements R3 and R4 where the relays did not meet the PRC-026-2 – Attachment B criteria. According to Requirement R2, the Generator Owner and Transmission Owner are only required to re-evaluate each load-responsive protective relay for an identified Element where the evaluation has not been performed in the last five calendar years.

Although Requirement R1 requires the Planning Coordinator to notify the respective Generator Owner and Transmission Owner of any Elements meeting one or more of the four criteria, it does not preclude the Planning Coordinator from providing additional information, such as apparent impedance characteristics, in advance or upon request, that may be useful in evaluating protective relays. Generator Owners and Transmission Owners are able to complete protective relay evaluations and perform the required actions without additional information. The standard does not include any requirement for the entities to provide information that is already being shared or exchanged between entities for operating needs. While a Requirement has not been included for the exchange of information, entities should recognize that relay performance needs to be measured against the most current information.

## **Requirement R2**

Requirement R2 requires the Generator Owner and Transmission Owner to evaluate its load-responsive protective relays to ensure that they are expected to not trip in response to stable power swings.



The PRC-026-2 – Attachment A lists the applicable load-responsive relays that must be evaluated which include phase distance, phase overcurrent, out-of-step tripping, and loss-of-field relay functions. Phase distance relays could include, but are not limited to, the following:

- Zone elements with instantaneous tripping or intentional time delays of less than 15 cycles
- Phase distance elements used in high-speed communication-aided tripping schemes including:
  - Directional Comparison Blocking (DCB) schemes
  - Directional Comparison Un-Blocking (DCUB) schemes
  - Permissive Overreach Transfer Trip (POTT) schemes
  - Permissive Underreach Transfer Trip (PUTT) schemes

A method is provided within the standard to support consistent evaluation by Generator Owners and Transmission Owners based on specified conditions. Once a Generator Owner or Transmission Owner is notified of Elements pursuant to Requirement R1, it has 12 full calendar months to determine if each Element's load-responsive protective relays meet the PRC-026-2 – Attachment B criteria, if the determination has not been performed in the last five calendar years. Additionally, each Generator Owner and Transmission Owner, that becomes aware of a generator, transformer, or transmission line BES Element that tripped in response to a stable or unstable power swing due to the operation of its protective relays pursuant to Requirement R2, Part 2.2, must perform the same PRC-026-2 – Attachment B criteria determination within 12 full calendar months.

### **Becoming Aware of an Element That Tripped in Response to a Power Swing**

Part 2.2 in Requirement R2 is intended to initiate action by the Generator Owner and Transmission Owner when there is a known stable or unstable power swing and it resulted in the entity's Element tripping. The criterion starts with becoming aware of the event (i.e., power swing) and then any connection with the entity's Element tripping. By doing so, the focus is removed from the entity having to demonstrate that it made a determination whether a power swing was present for every Element trip. The basis for structuring the criterion in this manner is driven by the available ways that a Generator Owner and Transmission Owner could become aware of an Element that tripped in response to a stable or unstable power swing due to the operation of its protective relay(s).

Element trips caused by stable or unstable power swings, though infrequent, would be more common in a larger event. The identification of power swings will be revealed during an analysis of the event. Event analysis where an entity may become aware of a stable or unstable power swing could include internal analysis conducted by the entity, the entity's Protection System review following a trip, or a larger scale analysis by other entities. Event analysis could include involvement by the entity's Regional Entity, and in some cases NERC.

### **Information Common to Both Generation and Transmission Elements**

The PRC-026-2 – Attachment A lists the load-responsive protective relays that are subject to this standard. Generator Owners and Transmission Owners may own load-responsive protective relays (e.g., distance relays) that directly affect generation or transmission BES Elements and will require analysis as a result of Elements being identified by the Planning Coordinator in Requirement R1

or the Generator Owner or Transmission Owner in Requirement R2. For example, distance relays owned by the Transmission Owner may be installed at the high-voltage side of the generator step-up (GSU) transformer (directional toward the generator) providing backup to generation protection. Generator Owners may have distance relays applied to backup transmission protection or backup protection to the GSU transformer. The Generator Owner may have relays installed at the generator terminals or the high-voltage side of the GSU transformer.

### Exclusion of Time Based Load-Responsive Protective Relays

The purpose of the standard is “[t]o ensure that load-responsive protective relays are expected to not trip in response to stable power swings during non-Fault conditions.” Load-responsive, high-speed tripping protective relays pose the highest risk of operating during a power swing. Because of this, high-speed tripping protective relays and relays with a time delay of less than 15 cycles are included in the standard; whereas other relays (i.e., Zones 2 and 3) with a time delay of 15 cycles or greater are excluded. The time delay used for exclusion on some load-responsive protective relays is based on the maximum expected time that load-responsive protective relays would be exposed to a stable power swing with a slow slip rate frequency.

In order to establish a time delay that distinguishes a high-risk load-responsive protective relay from one that has a time delay for tripping (lower-risk), a sample of swing rates were calculated based on a stable power swing entering and leaving the impedance characteristic as shown in Table 1. For a relay impedance characteristic that has a power swing entering and leaving, beginning at 90 degrees with a termination at 120 degrees before exiting the zone, the zone timer must be greater than the calculated time the stable power swing is inside the relay’s operating zone to not trip in response to the stable power swing.

$$\text{Eq. (1)} \quad \text{Zone timer} > 2 \times \left( \frac{(120^\circ - \text{Angle of entry into the relay characteristic}) \times 60}{(360 \times \text{Slip Rate})} \right)$$

Table 1: Swing Rates	
Zone Timer (Cycles)	Slip Rate (Hz)
10	1.00
15	0.67
20	0.50
30	0.33

With a minimum zone timer of 15 cycles, the corresponding slip rate of the system is 0.67 Hz. This represents an approximation of a slow slip rate during a system Disturbance. Longer time delays allow for slower slip rates.

## Application to Transmission Elements

Criterion A in PRC-026-2 – Attachment B describes an unstable power swing region that is formed by the union of three shapes in the impedance (R-X) plane. The first shape is a lower loss-of-synchronism circle based on a ratio of the sending-end to receiving-end voltages of 0.7 (i.e.,  $E_S / E_R = 0.7 / 1.0 = 0.7$ ). The second shape is an upper loss-of-synchronism circle based on a ratio of the sending-end to receiving-end voltages of 1.43 (i.e.,  $E_S / E_R = 1.0 / 0.7 = 1.43$ ). The third shape is a lens that connects the endpoints of the total system impedance together by varying the sending-end and receiving-end system voltages from 0.0 to 1.0 per unit, while maintaining a constant system separation angle across the total system impedance (with the parallel transfer impedance removed—see Figures 1 through 5). The total system impedance is derived from a two-bus equivalent network and is determined by summing the sending-end source impedance, the line impedance (excluding the Thévenin equivalent transfer impedance), and the receiving-end source impedance as shown in Figures 6 and 7. Establishing the total system impedance provides a conservative condition that will maximize the security of the relay against various system conditions. The smallest total system impedance represents a condition where the size of the lens characteristic in the R-X plane is smallest and is a conservative operating point from the standpoint of ensuring a load-responsive protective relay is expected to not trip given a predetermined angular displacement between the sending-end and receiving-end voltages. The smallest total system impedance results when all generation is in service and all transmission BES Elements are modeled in their “normal” system configuration (PRC-026-2 – Attachment B, Criterion A). The parallel transfer impedance is removed to represent a likely condition where parallel Elements may be lost during the disturbance, and the loss of these Elements magnifies the sensitivity of the load-responsive relays on the parallel line by removing the “infeed effect” (i.e., the apparent impedance sensed by the relay is decreased as a result of the loss of the transfer impedance, thus making the relay more likely to trip for a stable power swing—See Figures 13 and 14).

The sending-end and receiving-end source voltages are varied from 0.7 to 1.0 per unit to form the lower and upper loss-of-synchronism circles. The ratio of these two voltages is used in the calculation of the loss-of-synchronism circles, and result in a ratio range from 0.7 to 1.43.

$$\text{Eq. (2)} \quad \frac{E_S}{E_R} = \frac{0.7}{1.0} = 0.7 \qquad \text{Eq. (3):} \quad \frac{E_S}{E_R} = \frac{1.0}{0.7} = 1.43$$

The internal generator voltage during severe power swings or transmission system fault conditions will be greater than zero due to voltage regulator support. The voltage ratio of 0.7 to 1.43 is chosen to be more conservative than the PRC-023<sup>12</sup> and PRC-025<sup>13</sup> NERC Reliability Standards where a lower bound voltage of 0.85 per unit voltage is used. A  $\pm 15\%$  internal generator voltage range was chosen as a conservative voltage range for calculation of the voltage ratio used to calculate the loss-of-synchronism circles. For example, the voltage ratio using these voltages would result in a ratio range from 0.739 to 1.353.

---

<sup>12</sup> Transmission Relay Loadability

<sup>13</sup> Generator Relay Loadability

Eq. (4)  $\frac{E_S}{E_R} = \frac{0.85}{1.15} = 0.739$

Eq. (5):  $\frac{E_S}{E_R} = \frac{1.15}{0.85} = 1.353$

The lower ratio is rounded down to 0.7 to be more conservative, allowing a voltage range of 0.7 to 1.0 per unit to be used for the calculation of the loss-of-synchronism circles.<sup>14</sup>

When the parallel transfer impedance is included in the model, the division of current through the parallel transfer impedance path results in actual measured relay impedances that are larger than those measured when the parallel transfer impedance is removed (i.e., infeed effect), which would make it more likely for an impedance relay element to be completely contained within the unstable power swing region as shown in Figure 11. If the transfer impedance is included in the evaluation, a distance relay element could be deemed as meeting PRC-026-2 – Attachment B criteria and, in fact would be secure, assuming all Elements were in their normal state. In this case, the distance relay element could trip in response to a stable power swing during an actual event if the system was weakened (i.e., a higher transfer impedance) by the loss of a subset of lines that make up the parallel transfer impedance as shown in Figure 10. This could happen because the subset of lines that make up the parallel transfer impedance tripped on unstable swings, contained the initiating fault, and/or were lost due to operation of breaker failure or remote back-up protection schemes.

Table 10 shows the percent size increase of the lens shape as seen by the relay under evaluation when the parallel transfer impedance is included. The parallel transfer impedance has minimal effect on the apparent size of the lens shape as long as the parallel transfer impedance is at least 10 multiples of the parallel line impedance (less than 5% lens shape expansion), therefore, its removal has minimal impact, but results in a slightly more conservative, smaller lens shape. Parallel transfer impedances of 5 multiples of the parallel line impedance or less result in an apparent lens shape size of 10% or greater as seen by the relay. If two parallel lines and a parallel transfer impedance tie the sending-end and receiving-end buses together, the total parallel transfer impedance will be one or less multiples of the parallel line impedance, resulting in an apparent lens shape size of 45% or greater. It is a realistic contingency that the parallel line could be out-of-service, leaving the parallel transfer impedance making up the rest of the system in parallel with the line impedance. Since it is not known exactly which lines making up the parallel transfer impedance will be out of service during a major system disturbance, it is most conservative to assume that all of them are out, leaving just the line under evaluation in service.

Either the saturated transient or sub-transient direct axis reactance may be used for machines in the evaluation because they are smaller than the un-saturated reactances. Since saturated sub-transient generator reactances are smaller than the transient or synchronous reactances, the use of sub-transient reactances will result in a smaller source impedance and a smaller unstable power swing region in the graphical analysis as shown in Figures 8 and 9. Because power swings occur in a time frame where generator transient reactances will be prevalent, it is acceptable to use saturated transient reactances instead of saturated sub-transient reactances. Because some short-

---

<sup>14</sup> *Final Report on the August 14, 2003 Blackout in the United States and Canada: Causes and Recommendations*, April 2004, Section 6 (The Cascade Stage of the Blackout), p. 94 under “Why the Generators Tripped Off,” states, “Some generator undervoltage relays were set to trip at or above 90% voltage. However, a motor stalls out at about 70% voltage and a motor starter contactor drops out around 75%, so if there is a compelling need to protect the turbine from the system the under-voltage trigger point should be no higher than 80%.”

circuit models may not include transient reactances, the use of sub-transient reactances is also acceptable because it produces more conservative results. For this reason, either value is acceptable when determining the system source impedances (PRC-026-2 – Attachment B, Criterion A and B, No. 3).

Saturated reactances are used in short-circuit programs that produce the system impedance mentioned above. Planning and stability software generally use un-saturated reactances. Generator models used in transient stability analyses recognize that the extent of the saturation effect depends upon both rotor (field) and stator currents. Accordingly, they derive the effective saturated parameters of the machine at each instant by internal calculation from the specified (constant) unsaturated values of machine reactances and the instantaneous internal flux level. The specific assumptions regarding which inductances are affected by saturation, and the relative effect of that saturation, are different for the various generator models used. Thus, unsaturated values of all machine reactances are used in setting up planning and stability software data, and the appropriate set of open-circuit magnetization curve data is provided for each machine.

Saturated reactance values are smaller than unsaturated reactance values and are used in short-circuit programs owned by the Generator and Transmission Owners. Because of this, saturated reactance values are to be used in the development of the system source impedances.

The source or system equivalent impedances can be obtained by a number of different methods using commercially available short-circuit calculation tools.<sup>15</sup> Most short-circuit tools have a network reduction feature that allows the user to select the local and remote terminal buses to retain. The first method reduces the system to one that contains two buses, an equivalent generator at each bus (representing the source impedances at the sending-end and receiving-end), and two parallel lines; one being the line impedance of the protected line with relays being analyzed, the other being the parallel transfer impedance representing all other combinations of lines that connect the two buses together as shown in Figure 6. Another conservative method is to open both ends of the line being evaluated, and apply a three-phase bolted fault at each bus to determine the Thévenin equivalent impedance at each bus. The source impedances are set equal to the Thévenin equivalent impedances and will be less than or equal to the actual source impedances calculated by the network reduction method. Either method can be used to develop the system source impedances at both ends.

The two bullets of PRC-026-2 – Attachment B, Criterion A, No. 1, identify the system separation angles used to identify the size of the power swing stability boundary for evaluating load-responsive protective relay impedance elements. The first bullet of PRC-026-2 – Attachment B, Criterion A, No. 1 evaluates a system separation angle of at least 120 degrees that is held constant while varying the sending-end and receiving-end source voltages from 0.7 to 1.0 per unit, thus creating an unstable power swing region about the total system impedance in Figure 1. This unstable power swing region is compared to the tripping portion of the distance relay characteristic; that is, the portion that is not supervised by load encroachment, blinders, or some other form of supervision as shown in Figure 12 that restricts the distance element from tripping

---

<sup>15</sup> Demetrios A. Tziouvaras and Daqing Hou, Appendix in *Out-Of-Step Protection Fundamentals and Advancements*, April 17, 2014: <https://www.selinc.com>.

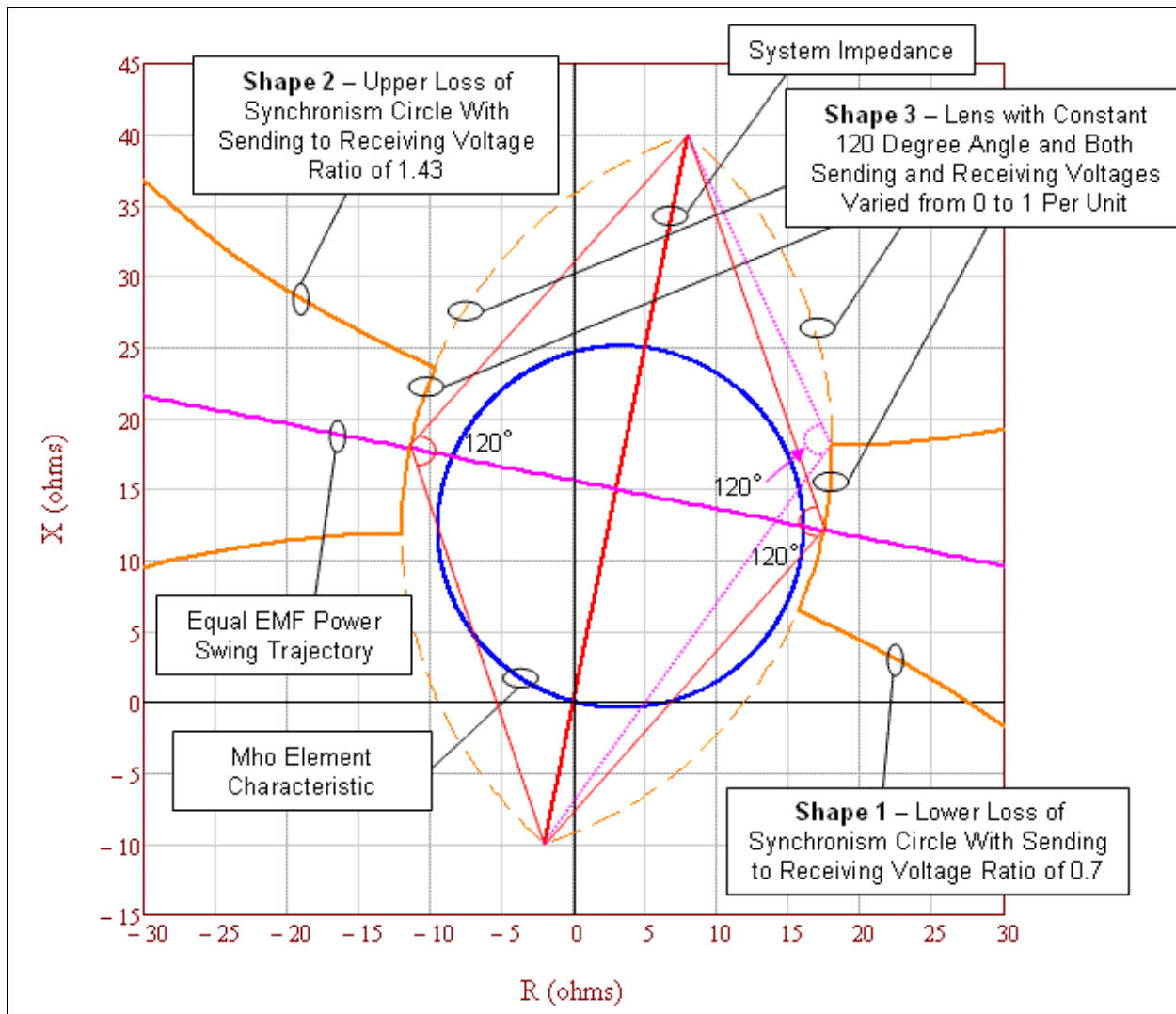
for heavy, balanced load conditions. If the tripping portion of the impedance characteristics are completely contained within the unstable power swing region, the relay impedance element meets Criterion A in PRC-026-2 – Attachment B. A system separation angle of 120 degrees was chosen for the evaluation because it is generally accepted in the industry that recovery for a swing beyond this angle is unlikely to occur.<sup>16</sup>

The second bullet of PRC-026-2 – Attachment B, Criterion A, No. 1 evaluates impedance relay elements at a system separation angle of less than 120 degrees, similar to the first bullet described above. An angle less than 120 degrees may be used if a documented stability analysis demonstrates that the power swing becomes unstable at a system separation angle of less than 120 degrees.

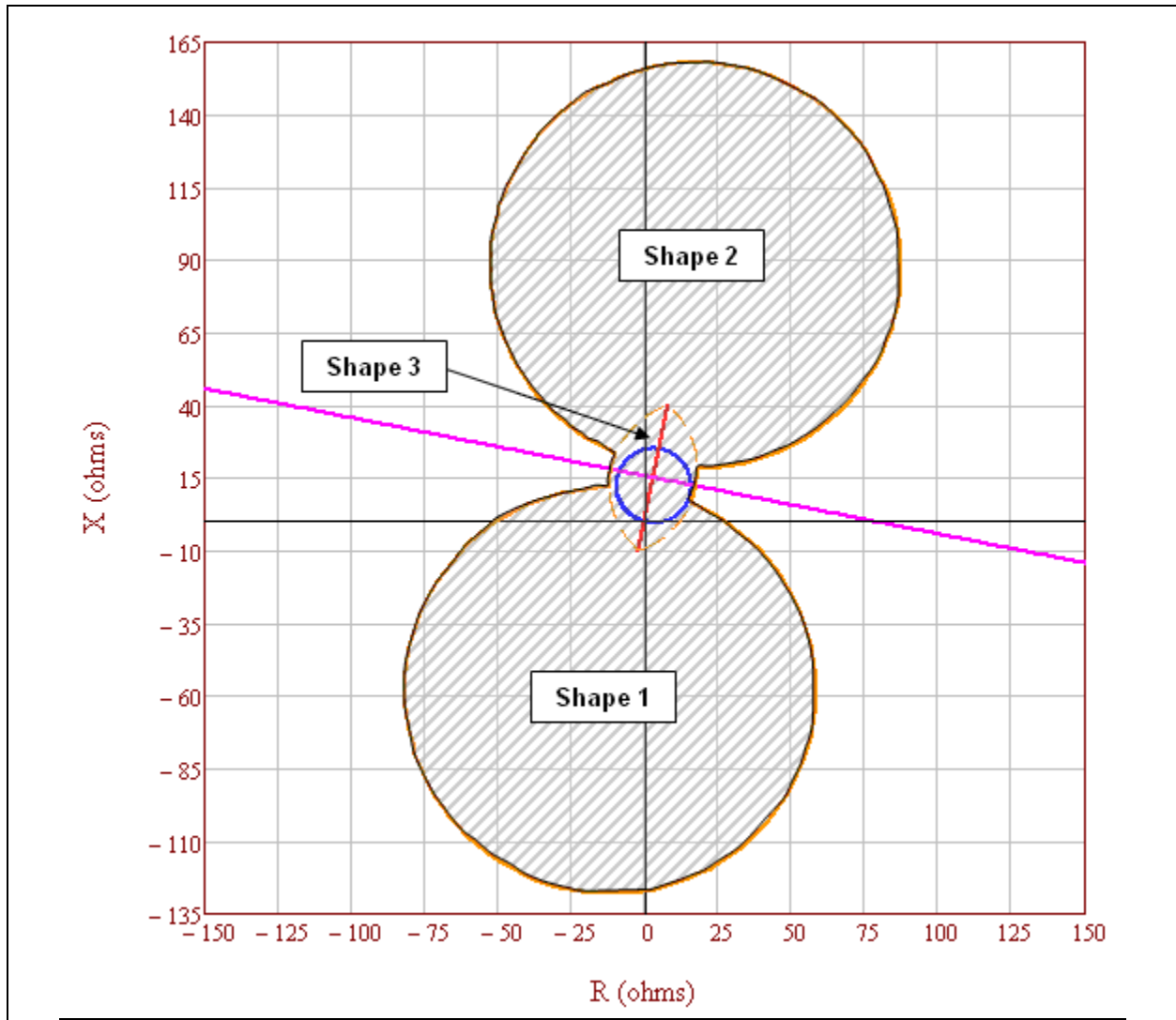
The exclusion of relay elements supervised by Power Swing Blocking (PSB) in PRC-026-2 – Attachment A allows the Generator Owner or Transmission Owner to exclude protective relay elements if they are blocked from tripping by PSB relays. A PSB relay applied and set according to industry accepted practices prevent supervised load-responsive protective relays from tripping in response to power swings. Further, PSB relays are set to allow dependable tripping of supervised elements. The criteria in PRC-026-2 – Attachment B specifically applies to unsupervised elements that could trip for stable power swings. Therefore, load-responsive protective relay elements supervised by PSB can be excluded from the Requirements of this standard.

---

<sup>16</sup> “The critical angle for maintaining stability will vary depending on the contingency and the system condition at the time the contingency occurs; however, the likelihood of recovering from a swing that exceeds 120 degrees is marginal and 120 degrees is generally accepted as an appropriate basis for setting out-of-step protection. Given the importance of separating unstable systems, defining 120 degrees as the critical angle is appropriate to achieve a proper balance between dependable tripping for unstable power swings and secure operation for stable power swings.” NERC System Protection and Control Subcommittee, *Protection System Response to Power Swings*, August 2013: [http://www.nerc.com/comm/PC/System%20Protection%20and%20Control%20Subcommittee%20SPCS%2020/SPCS%20Power%20Swing%20Report\\_Final\\_20131015.pdf](http://www.nerc.com/comm/PC/System%20Protection%20and%20Control%20Subcommittee%20SPCS%2020/SPCS%20Power%20Swing%20Report_Final_20131015.pdf), p. 28.

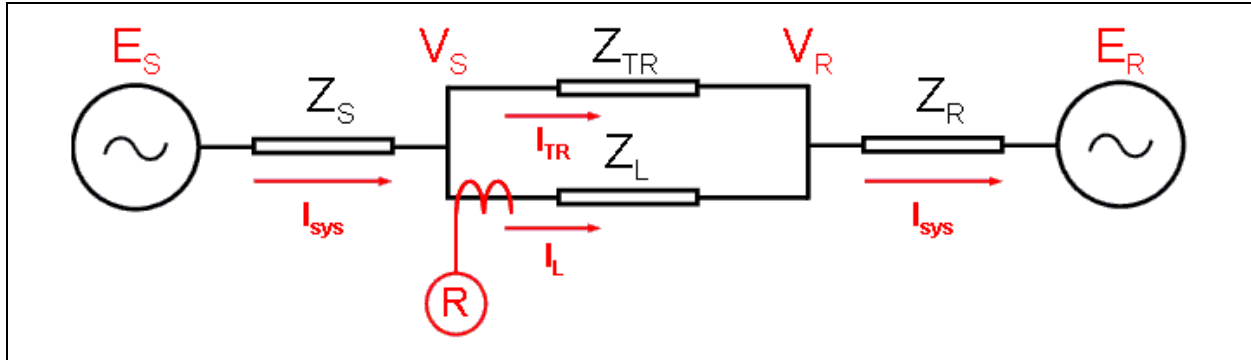


**Figure 1:** An enlarged graphic illustrating the unstable power swing region formed by the union of three shapes in the impedance (R-X) plane: Shape 1) Lower loss-of-synchronism circle, Shape 2) Upper loss-of-synchronism circle, and Shape 3) Lens. The mho element characteristic is completely contained within the unstable power swing region (i.e., it does not intersect any portion of the unstable power swing region), therefore it meets PRC-026-2 – Attachment B, Criterion A, No. 1.

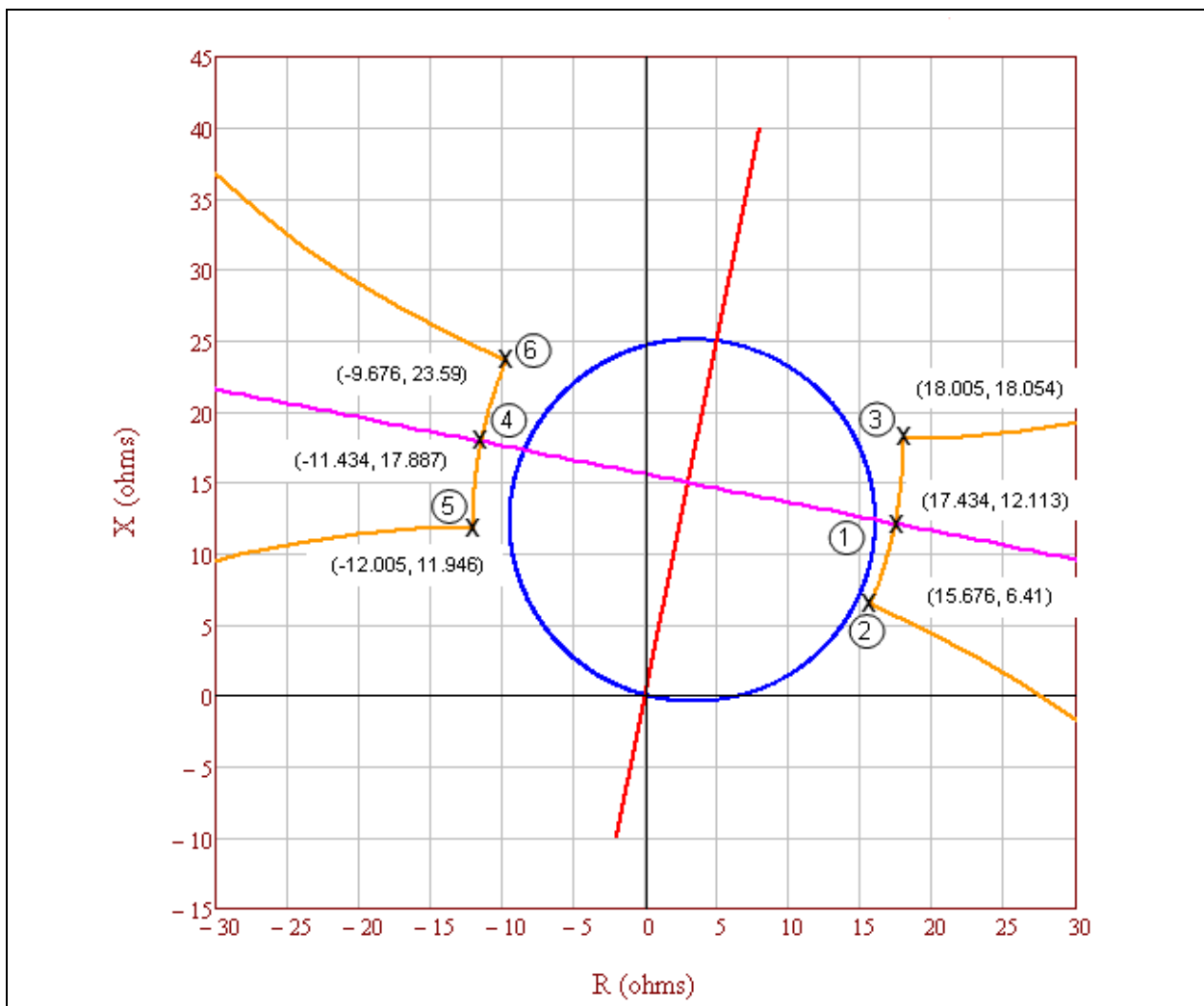


**Figure 2:** Full graphic of the unstable power swing region formed by the union of the three shapes in the impedance (R-X) plane: Shape 1) Lower loss-of-synchronism circle, Shape 2) Upper loss-of-synchronism circle, and Shape 3) Lens. The mho element characteristic is completely contained within the unstable power swing region, therefore it meets PRC-26-1 – Attachment B, Criterion A, No.1.





**Figure 3:** System impedances as seen by Relay R (voltage connections are not shown).



**Figure 4:** The defining unstable power swing region points where the lens shape intersects the lower and upper loss-of-synchronism circle shapes and where the lens intersects the equal EMF (electromotive force) power swing.

E <sub>S</sub> / E <sub>R</sub> Voltage Ratio	Left Side Coordinates		Right Side Coordinates	
	R	+ jX	R	+ jX
<b>0.7</b>	<b>-12.005</b>	<b>11.946</b>	<b>15.676</b>	<b>6.41</b>
0.72	-12.004	12.407	15.852	6.836
0.74	-11.996	12.857	16.018	7.255
0.76	-11.982	13.298	16.175	7.667
0.78	-11.961	13.729	16.321	8.073
0.8	-11.935	14.151	16.459	8.472
0.82	-11.903	14.563	16.589	8.865
0.84	-11.867	14.966	16.71	9.251
0.86	-11.826	15.361	16.824	9.631
0.88	-11.78	15.746	16.93	10.004
0.9	-11.731	16.123	17.03	10.371
0.92	-11.678	16.492	17.123	10.732
0.94	-11.621	16.852	17.209	11.086
0.96	-11.562	17.205	17.29	11.435
0.98	-11.499	17.55	17.364	11.777
<b>1</b>	<b>-11.434</b>	<b>17.887</b>	<b>17.434</b>	<b>12.113</b>
1.0286	-11.336	18.356	17.524	12.584
1.0572	-11.234	18.81	17.604	13.043
1.0858	-11.127	19.251	17.675	13.49
1.1144	-11.017	19.677	17.738	13.926
1.143	-10.904	20.091	17.792	14.351
1.1716	-10.788	20.491	17.84	14.766
1.2002	-10.67	20.88	17.88	15.17
1.2288	-10.55	21.256	17.914	15.564
1.2574	-10.428	21.621	17.942	15.948
1.286	-10.304	21.975	17.964	16.322
1.3146	-10.18	22.319	17.981	16.687
1.3432	-10.054	22.652	17.993	17.043
1.3718	-9.928	22.976	18.001	17.39
1.4004	-9.801	23.29	18.005	17.728
<b>1.429</b>	<b>-9.676</b>	<b>23.59</b>	<b>18.005</b>	<b>18.054</b>

**Figure 5:** Full table of 31 detailed lens shape point calculations. The bold highlighted rows correspond to the detailed calculations in Tables 2-7.

Table 2: Example Calculation (Lens Point 1)	
This example is for calculating the impedance the first point of the lens characteristic. Equal source voltages are used for the 230 kV (base) line with the sending-end voltage (E <sub>S</sub> ) leading the receiving-end voltage (E <sub>R</sub> ) by 120 degrees. See Figures 3 and 4.	
Eq. (6)	$E_S = \frac{V_{LL} \angle 120^\circ}{\sqrt{3}}$

Table 2: Example Calculation (Lens Point 1)			
	$E_S = \frac{230,000 \angle 120^\circ V}{\sqrt{3}}$		
	$E_S = 132,791 \angle 120^\circ V$		
Eq. (7)	$E_R = \frac{V_{LL} \angle 0^\circ}{\sqrt{3}}$		
	$E_R = \frac{230,000 \angle 0^\circ V}{\sqrt{3}}$		
	$E_R = 132,791 \angle 0^\circ V$		
Positive sequence impedance data (with transfer impedance $Z_{TR}$ set to a large value).			
Given:	$Z_S = 2 + j10 \Omega$	$Z_L = 4 + j20 \Omega$	$Z_R = 4 + j20 \Omega$
Given:	$Z_{TR} = Z_L \times 10^{10} \Omega$		
Total impedance between the generators.			
Eq. (8)	$Z_{total} = \frac{(Z_L \times Z_{TR})}{(Z_L + Z_{TR})}$		
	$Z_{total} = \frac{((4 + j20) \Omega \times (4 + j20) \times 10^{10} \Omega)}{((4 + j20) \Omega + (4 + j20) \times 10^{10} \Omega)}$		
	$Z_{total} = 4 + j20 \Omega$		
Total system impedance.			
Eq. (9)	$Z_{sys} = Z_S + Z_{total} + Z_R$		
	$Z_{sys} = (2 + j10) \Omega + (4 + j20) \Omega + (4 + j20) \Omega$		
	$Z_{sys} = 10 + j50 \Omega$		
Total system current from sending-end source.			
Eq. (10)	$I_{sys} = \frac{E_S - E_R}{Z_{sys}}$		
	$I_{sys} = \frac{132,791 \angle 120^\circ V - 132,791 \angle 0^\circ V}{(10 + j50) \Omega}$		
	$I_{sys} = 4,511 \angle 71.3^\circ A$		
The current, as measured by the relay on $Z_L$ (Figure 3), is only the current flowing through that line as determined by using the current divider equation.			
Eq. (11)	$I_L = I_{sys} \times \frac{Z_{TR}}{Z_L + Z_{TR}}$		

Table 2: Example Calculation (Lens Point 1)	
	$I_L = 4,511\angle 71.3^\circ A \times \frac{(4 + j20) \times 10^{10} \Omega}{(4 + j20) \Omega + (4 + j20) \times 10^{10} \Omega}$
	$I_L = 4,511\angle 71.3^\circ A$
The voltage, as measured by the relay on $Z_L$ (Figure 3), is the voltage drop from the sending-end source through the sending-end source impedance.	
Eq. (12)	$V_S = E_S - (Z_S \times I_{sys})$
	$V_S = 132,791\angle 120^\circ V - [(2 + j10) \Omega \times 4,511\angle 71.3^\circ A]$
	$V_S = 95,757\angle 106.1^\circ V$
The impedance seen by the relay on $Z_L$ .	
Eq. (13)	$Z_{L-Relay} = \frac{V_S}{I_L}$
	$Z_{L-Relay} = \frac{95,757\angle 106.1^\circ V}{4,511\angle 71.3^\circ A}$
	$Z_{L-Relay} = 17.434 + j12.113 \Omega$

Table 3: Example Calculation (Lens Point 2)	
This example is for calculating the impedance second point of the lens characteristic. Unequal source voltages are used for the 230 kV (base) line with the sending-end voltage ( $E_S$ ) at 70% of the receiving-end voltage ( $E_R$ ) and leading the receiving-end voltage by 120 degrees. See Figures 3 and 4.	
Eq. (14)	$E_S = \frac{V_{LL}\angle 120^\circ}{\sqrt{3}} \times 70\%$
	$E_S = \frac{230,000\angle 120^\circ V}{\sqrt{3}} \times 0.70$
	$E_S = 92,953.7\angle 120^\circ V$
Eq. (15)	$E_R = \frac{V_{LL}\angle 0^\circ}{\sqrt{3}}$
	$E_R = \frac{230,000\angle 0^\circ V}{\sqrt{3}}$
	$E_R = 132,791\angle 0^\circ V$
Positive sequence impedance data (with transfer impedance $Z_{TR}$ set to a large value).	
Given:	$Z_S = 2 + j10 \Omega$ $Z_L = 4 + j20 \Omega$ $Z_R = 4 + j20 \Omega$
Given:	$Z_{TR} = Z_L \times 10^{10} \Omega$

Table 3: Example Calculation (Lens Point 2)	
Total impedance between the generators.	
Eq. (16)	$Z_{total} = \frac{(Z_L \times Z_{TR})}{(Z_L + Z_{TR})}$
	$Z_{total} = \frac{((4 + j20) \Omega \times (4 + j20) \times 10^{10} \Omega)}{((4 + j20) \Omega + (4 + j20) \times 10^{10} \Omega)}$
	$Z_{total} = 4 + j20 \Omega$
Total system impedance.	
Eq. (17)	$Z_{sys} = Z_S + Z_{total} + Z_R$
	$Z_{sys} = (2 + j10) \Omega + (4 + j20) \Omega + (4 + j20) \Omega$
	$Z_{sys} = 10 + j50 \Omega$
Total system current from sending-end source.	
Eq. (18)	$I_{sys} = \frac{E_S - E_R}{Z_{sys}}$
	$I_{sys} = \frac{92,953.7 \angle 120^\circ V - 132,791 \angle 0^\circ V}{(10 + j50) \Omega}$
	$I_{sys} = 3,854 \angle 77^\circ A$
The current, as measured by the relay on $Z_L$ (Figure 3), is only the current flowing through that line as determined by using the current divider equation.	
Eq. (19)	$I_L = I_{sys} \times \frac{Z_{TR}}{Z_L + Z_{TR}}$
	$I_L = 3,854 \angle 77^\circ A \times \frac{(4 + j20) \times 10^{10} \Omega}{(4 + j20) \Omega + (4 + j20) \times 10^{10} \Omega}$
	$I_L = 3,854 \angle 77^\circ A$
The voltage, as measured by the relay on $Z_L$ (Figure 3), is the voltage drop from the sending-end source through the sending-end source impedance.	
Eq. (20)	$V_S = E_S - (Z_S \times I_{sys})$
	$V_S = 92,953 \angle 120^\circ V - [(2 + j10) \Omega \times 3,854 \angle 77^\circ A]$
	$V_S = 65,271 \angle 99^\circ V$
The impedance seen by the relay on $Z_L$ .	
Eq. (21)	$Z_{L-Relay} = \frac{V_S}{I_L}$

Table 3: Example Calculation (Lens Point 2)	
	$Z_{L-Relay} = \frac{65,271 \angle 99^\circ V}{3,854 \angle 77^\circ A}$
	$Z_{L-Relay} = 15.676 + j6.41 \Omega$

Table 4: Example Calculation (Lens Point 3)	
This example is for calculating the impedance third point of the lens characteristic. Unequal source voltages are used for the 230 kV (base) line with the receiving-end voltage ( $E_R$ ) at 70% of the sending-end voltage ( $E_S$ ) and the sending-end voltage leading the receiving-end voltage by 120 degrees. See Figures 3 and 4.	
Eq. (22)	$E_S = \frac{V_{LL} \angle 120^\circ}{\sqrt{3}}$
	$E_S = \frac{230,000 \angle 120^\circ V}{\sqrt{3}}$
	$E_S = 132,791 \angle 120^\circ V$
Eq. (23)	$E_R = \frac{V_{LL} \angle 0^\circ}{\sqrt{3}} \times 70\%$
	$E_R = \frac{230,000 \angle 0^\circ V}{\sqrt{3}} \times 0.70$
	$E_R = 92,953.7 \angle 0^\circ V$
Positive sequence impedance data (with transfer impedance $Z_{TR}$ set to a large value).	
Given:	$Z_S = 2 + j10 \Omega$ $Z_L = 4 + j20 \Omega$ $Z_R = 4 + j20 \Omega$
Given:	$Z_{TR} = Z_L \times 10^{10} \Omega$
Total impedance between the generators.	
Eq. (24)	$Z_{total} = \frac{(Z_L \times Z_{TR})}{(Z_L + Z_{TR})}$
	$Z_{total} = \frac{((4 + j20) \Omega \times (4 + j20) \times 10^{10} \Omega)}{((4 + j20) \Omega + (4 + j20) \times 10^{10} \Omega)}$
	$Z_{total} = 4 + j20 \Omega$
Total system impedance.	
Eq. (25)	$Z_{sys} = Z_S + Z_{total} + Z_R$
	$Z_{sys} = (2 + j10) \Omega + (4 + j20) \Omega + (4 + j20) \Omega$
	$Z_{sys} = 10 + j50 \Omega$

Table 4: Example Calculation (Lens Point 3)	
Total system current from sending-end source.	
Eq. (26)	$I_{sys} = \frac{E_S - E_R}{Z_{sys}}$
	$I_{sys} = \frac{132,791 \angle 120^\circ V - 92,953.7 \angle 0^\circ V}{(10 + j50) \Omega}$
	$I_{sys} = 3,854 \angle 65.5^\circ A$
The current, as measured by the relay on $Z_L$ (Figure 3), is only the current flowing through that line as determined by using the current divider equation.	
Eq. (27)	$I_L = I_{sys} \times \frac{Z_{TR}}{Z_L + Z_{TR}}$
	$I_L = 3,854 \angle 65.5^\circ A \times \frac{(4 + j20) \times 10^{10} \Omega}{(4 + j20) \Omega + (4 + j20) \times 10^{10} \Omega}$
	$I_L = 3,854 \angle 65.5^\circ A$
The voltage, as measured by the relay on $Z_L$ (Figure 3), is the voltage drop from the sending-end source through the sending-end source impedance.	
Eq. (28)	$V_S = E_S - (Z_S \times I_L)$
	$V_S = 132,791 \angle 120^\circ V - [(2 + j10) \Omega \times 3,854 \angle 65.5^\circ A]$
	$V_S = 98,265 \angle 110.6^\circ V$
The impedance seen by the relay on $Z_L$ .	
Eq. (29)	$Z_{L-Relay} = \frac{V_S}{I_L}$
	$Z_{L-Relay} = \frac{98,265 \angle 110.6^\circ V}{3,854 \angle 65.5^\circ A}$
	$Z_{L-Relay} = 18.005 + j18.054 \Omega$

Table 5: Example Calculation (Lens Point 4)	
This example is for calculating the impedance fourth point of the lens characteristic. Equal source voltages are used for the 230 kV (base) line with the sending-end voltage ( $E_S$ ) leading the receiving-end voltage ( $E_R$ ) by 240 degrees. See Figures 3 and 4.	
Eq. (30)	$E_S = \frac{V_{LL} \angle 240^\circ}{\sqrt{3}}$
	$E_S = \frac{230,000 \angle 240^\circ V}{\sqrt{3}}$

Table 5: Example Calculation (Lens Point 4)			
	$E_S = 132,791 \angle 240^\circ V$		
Eq. (31)	$E_R = \frac{V_{LL} \angle 0^\circ}{\sqrt{3}}$		
	$E_R = \frac{230,000 \angle 0^\circ V}{\sqrt{3}}$		
	$E_R = 132,791 \angle 0^\circ V$		
Positive sequence impedance data (with transfer impedance $Z_{TR}$ set to a large value).			
Given:	$Z_S = 2 + j10 \Omega$	$Z_L = 4 + j20 \Omega$	$Z_R = 4 + j20 \Omega$
Given:	$Z_{TR} = Z_L \times 10^{10} \Omega$		
Total impedance between the generators.			
Eq. (32)	$Z_{total} = \frac{(Z_L \times Z_{TR})}{(Z_L + Z_{TR})}$		
	$Z_{total} = \frac{((4 + j20) \Omega \times (4 + j20) \times 10^{10} \Omega)}{((4 + j20) \Omega + (4 + j20) \times 10^{10} \Omega)}$		
	$Z_{total} = 4 + j20 \Omega$		
Total system impedance.			
Eq. (33)	$Z_{sys} = Z_S + Z_{total} + Z_R$		
	$Z_{sys} = (2 + j10) \Omega + (4 + j20) \Omega + (4 + j20) \Omega$		
	$Z_{sys} = 10 + j50 \Omega$		
Total system current from sending-end source.			
Eq. (34)	$I_{sys} = \frac{E_S - E_R}{Z_{sys}}$		
	$I_{sys} = \frac{132,791 \angle 240^\circ V - 132,791 \angle 0^\circ V}{(10 + j50) \Omega}$		
	$I_{sys} = 4,511 \angle 131.3^\circ A$		
The current, as measured by the relay on $Z_L$ (Figure 3), is only the current flowing through that line as determined by using the current divider equation.			
Eq. (35)	$I_L = I_{sys} \times \frac{Z_{TR}}{Z_L + Z_{TR}}$		
	$I_L = 4,511 \angle 131.1^\circ A \times \frac{(4 + j20) \times 10^{10} \Omega}{(4 + j20) \Omega + (4 + j20) \times 10^{10} \Omega}$		
	$I_L = 4,511 \angle 131.1^\circ A$		



**Table 5: Example Calculation (Lens Point 4)**

The voltage, as measured by the relay on $Z_L$ (Figure 3), is the voltage drop from the sending-end source through the sending-end source impedance.	
Eq. (36)	$V_S = E_S - (Z_S \times I_L)$
	$V_S = 132,791 \angle 240^\circ V - [(2 + j10) \Omega \times 4,511 \angle 131.1^\circ A]$
	$V_S = 95,756 \angle -106.1^\circ V$
The impedance seen by the relay on $Z_L$ .	
Eq. (37)	$Z_{L-Relay} = \frac{V_S}{I_L}$
	$Z_{L-Relay} = \frac{95,756 \angle -106.1^\circ V}{4,511 \angle 131.1^\circ A}$
	$Z_{L-Relay} = -11.434 + j17.887 \Omega$

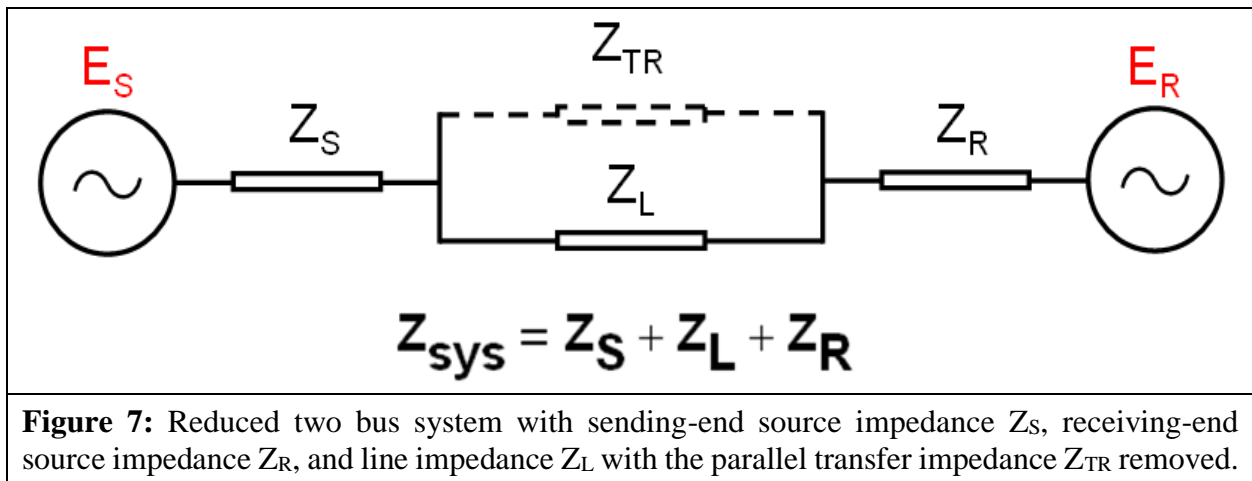
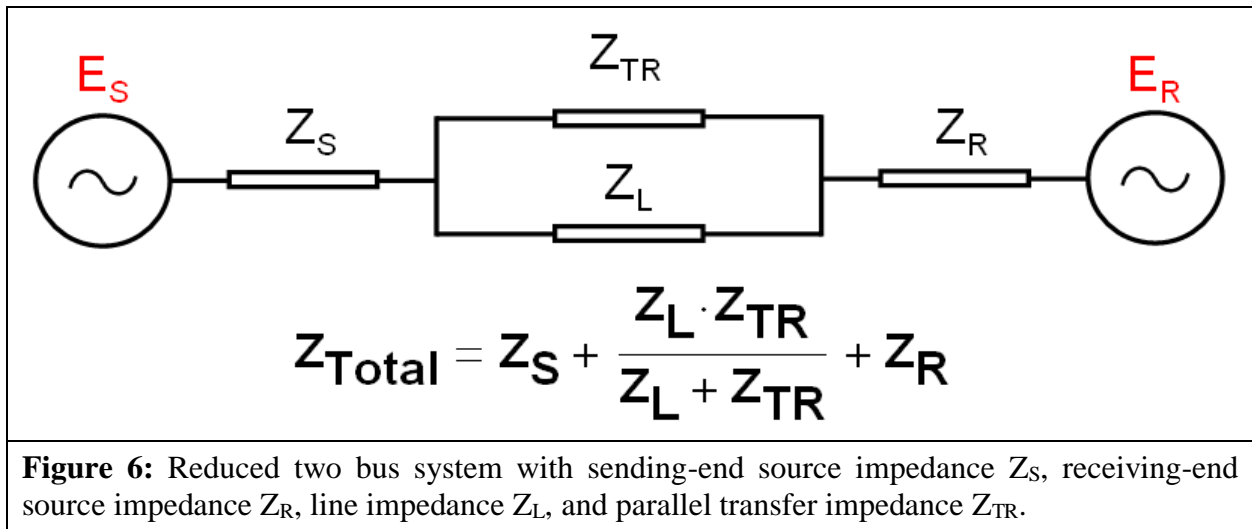
**Table 6: Example Calculation (Lens Point 5)**

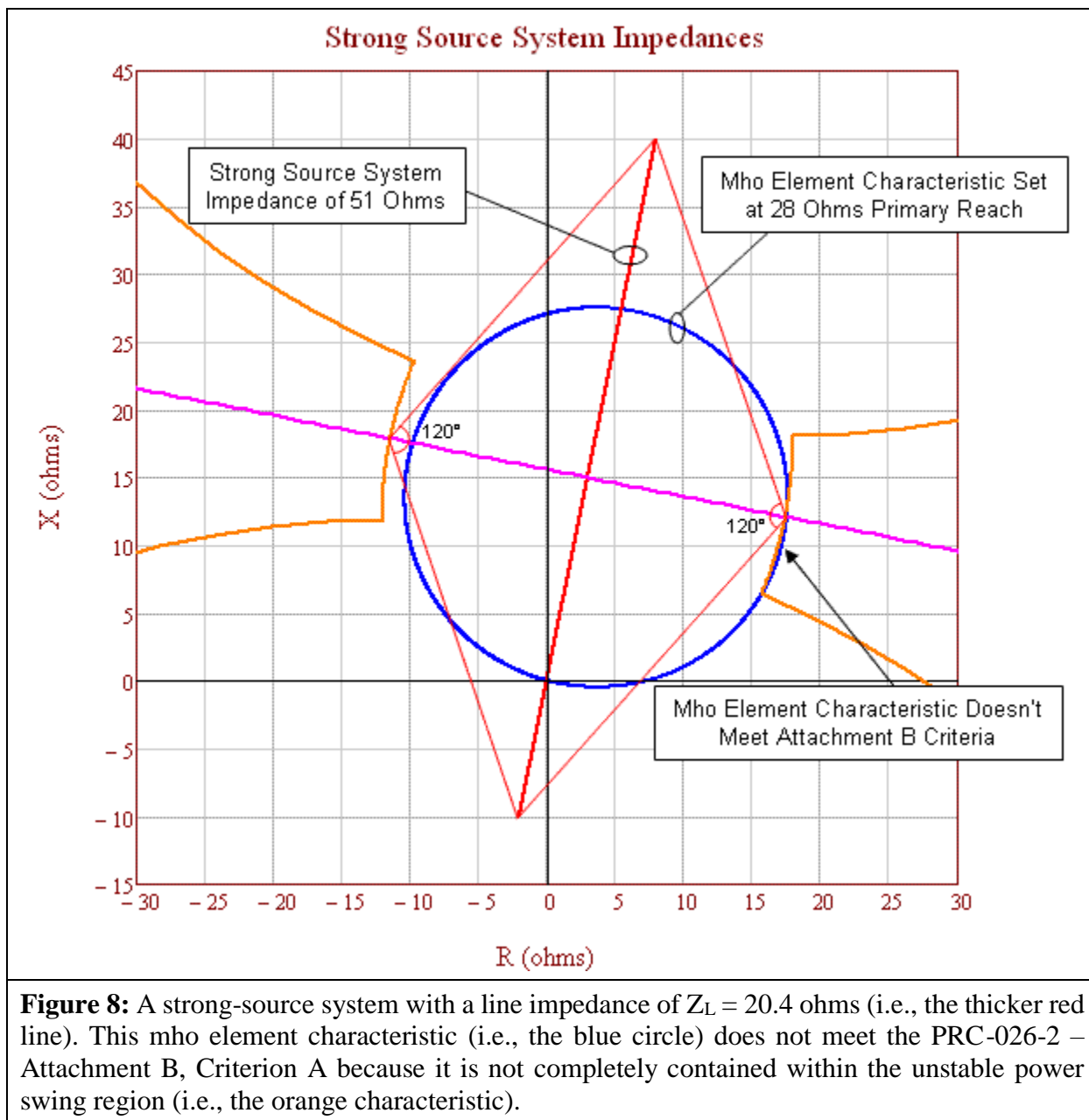
This example is for calculating the impedance fifth point of the lens characteristic. Unequal source voltages are used for the 230 kV (base) line with the sending-end voltage ( $E_S$ ) at 70% of the receiving-end voltage ( $E_R$ ) and leading the receiving-end voltage by 240 degrees. See Figures 3 and 4.	
Eq. (38)	$E_S = \frac{V_{LL} \angle 240^\circ}{\sqrt{3}} \times 70\%$
	$E_S = \frac{230,000 \angle 240^\circ V}{\sqrt{3}} \times 0.70$
	$E_S = 92,953.7 \angle 240^\circ V$
Eq. (39)	$E_R = \frac{V_{LL} \angle 0^\circ}{\sqrt{3}}$
	$E_R = \frac{230,000 \angle 0^\circ V}{\sqrt{3}}$
	$E_R = 132,791 \angle 0^\circ V$
Positive sequence impedance data (with transfer impedance $Z_{TR}$ set to a large value).	
Given:	$Z_S = 2 + j10 \Omega$ $Z_L = 4 + j20 \Omega$ $Z_R = 4 + j20 \Omega$
Given:	$Z_{TR} = Z_L \times 10^{10} \Omega$
Total impedance between the generators.	
Eq. (40)	$Z_{total} = \frac{(Z_L \times Z_{TR})}{(Z_L + Z_{TR})}$

Table 6: Example Calculation (Lens Point 5)	
	$Z_{total} = \frac{((4 + j20) \Omega \times (4 + j20) \times 10^{10} \Omega)}{((4 + j20) \Omega + (4 + j20) \times 10^{10} \Omega)}$
	$Z_{total} = 4 + j20 \Omega$
Total system impedance.	
Eq. (41)	$Z_{sys} = Z_S + Z_{total} + Z_R$
	$Z_{sys} = (2 + j10 \Omega) + (4 + j20 \Omega) + (4 + j20 \Omega)$
	$Z_{sys} = 10 + j50 \Omega$
Total system current from sending-end source.	
Eq. (42)	$I_{sys} = \frac{E_S - E_R}{Z_{sys}}$
	$I_{sys} = \frac{92,953.7 \angle 240^\circ V - 132,791 \angle 0^\circ V}{10 + j50 \Omega}$
	$I_{sys} = 3,854 \angle 125.5^\circ A$
The current, as measured by the relay on $Z_L$ (Figure 3), is only the current flowing through that line as determined by using the current divider equation.	
Eq. (43)	$I_L = I_{sys} \times \frac{Z_{TR}}{Z_L + Z_{TR}}$
	$I_L = 3,854 \angle 125.5^\circ A \times \frac{(4 + j20) \times 10^{10} \Omega}{(4 + j20) \Omega + (4 + j20) \times 10^{10} \Omega}$
	$I_L = 3,854 \angle 125.5^\circ A$
The voltage, as measured by the relay on $Z_L$ (Figure 3), is the voltage drop from the sending-end source through the sending-end source impedance.	
Eq. (44)	$V_S = E_S - (Z_S \times I_L)$
	$V_S = 92,953.7 \angle 240^\circ V - [(2 + j10) \Omega \times 3,854 \angle 125.5^\circ A]$
	$V_S = 65,270.5 \angle -99.4^\circ V$
The impedance seen by the relay on $Z_L$ .	
Eq. (45)	$Z_{L-Relay} = \frac{V_S}{I_L}$
	$Z_{L-Relay} = \frac{65,270.5 \angle -99.4^\circ V}{3,854 \angle 125.5^\circ A}$
	$Z_{L-Relay} = -12.005 + j11.946 \Omega$

<b>Table 7: Example Calculation (Lens Point 6)</b>			
This example is for calculating the impedance sixth point of the lens characteristic. Unequal source voltages are used for the 230 kV (base) line with the receiving-end voltage ( $E_R$ ) at 70% of the sending-end voltage ( $E_S$ ) and the sending-end voltage leading the receiving-end voltage by 240 degrees. See Figures 3 and 4.			
Eq. (46)	$E_S = \frac{V_{LL} \angle 240^\circ}{\sqrt{3}}$		
	$E_S = \frac{230,000 \angle 240^\circ V}{\sqrt{3}}$		
	$E_S = 132,791 \angle 240^\circ V$		
Eq. (47)	$E_R = \frac{V_{LL} \angle 0^\circ}{\sqrt{3}} \times 70\%$		
	$E_R = \frac{230,000 \angle 0^\circ V}{\sqrt{3}} \times 0.70$		
	$E_R = 92,953.7 \angle 0^\circ V$		
Positive sequence impedance data (with transfer impedance $Z_{TR}$ set to a large value).			
Given:	$Z_S = 2 + j10 \Omega$	$Z_L = 4 + j20 \Omega$	$Z_R = 4 + j20 \Omega$
Given:	$Z_{TR} = Z_L \times 10^{10} \Omega$		
Total impedance between the generators.			
Eq. (48)	$Z_{total} = \frac{(Z_L \times Z_{TR})}{(Z_L + Z_{TR})}$		
	$Z_{total} = \frac{((4 + j20) \Omega \times (4 + j20) \times 10^{10} \Omega)}{((4 + j20) \Omega + (4 + j20) \times 10^{10} \Omega)}$		
	$Z_{total} = 4 + j20 \Omega$		
Total system impedance.			
Eq. (49)	$Z_{sys} = Z_S + Z_{total} + Z_R$		
	$Z_{sys} = (2 + j10) \Omega + (4 + j20) \Omega + (4 + j20) \Omega$		
	$Z_{sys} = 10 + j50 \Omega$		
Total system current from sending-end source.			
Eq. (50)	$I_{sys} = \frac{E_S - E_R}{Z_{sys}}$		
	$I_{sys} = \frac{132,791 \angle 240^\circ V - 92,953.7 \angle 0^\circ V}{10 + j50 \Omega}$		
	$I_{sys} = 3,854 \angle 137.1^\circ A$		

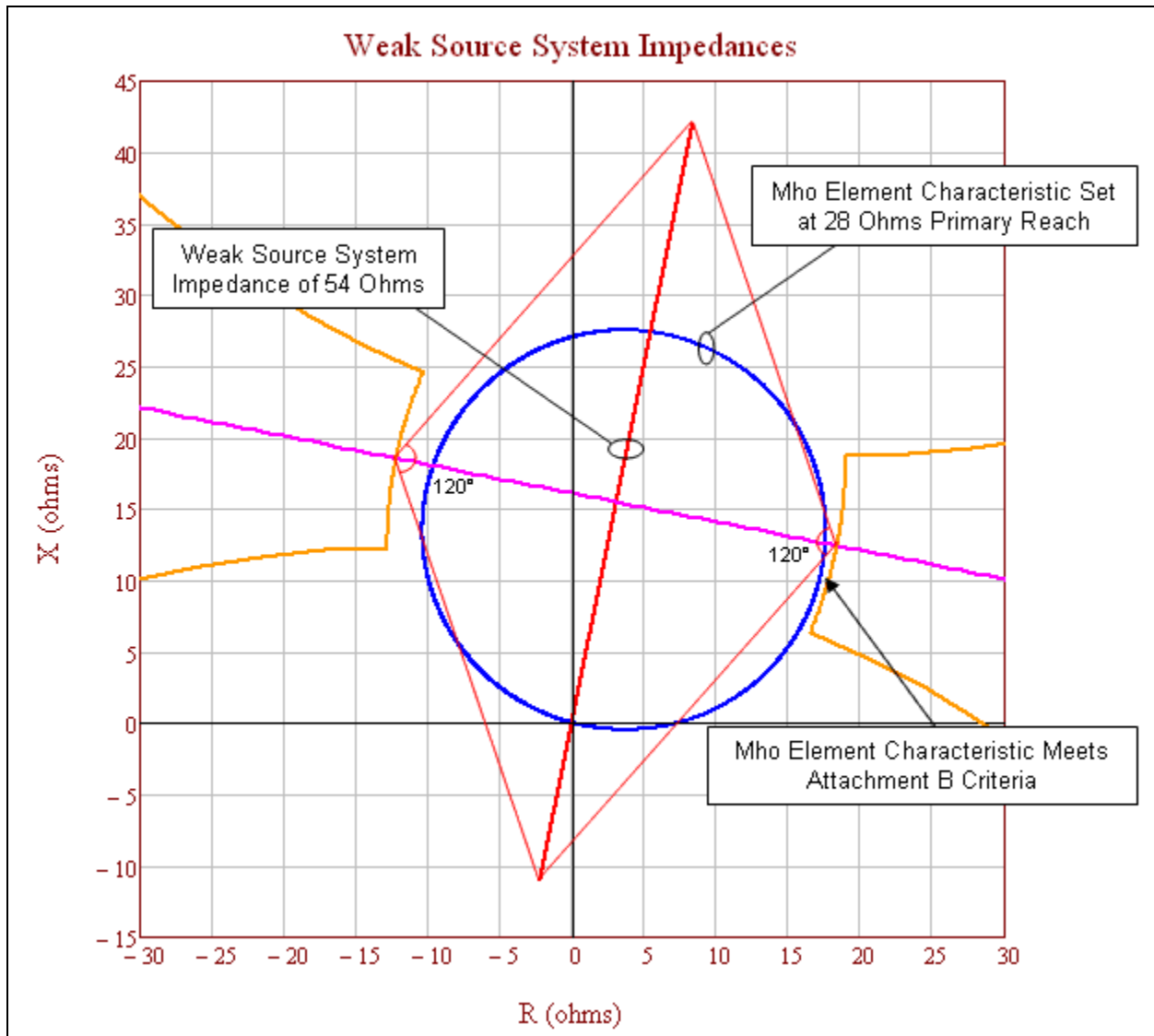
<b>Table 7: Example Calculation (Lens Point 6)</b>	
The current, as measured by the relay on $Z_L$ (Figure 3), is only the current flowing through that line as determined by using the current divider equation.	
Eq. (51)	$I_L = I_{sys} \times \frac{Z_{TR}}{Z_L + Z_{TR}}$
	$I_L = 3,854 \angle 137.1^\circ A \times \frac{(4 + j20) \times 10^{10} \Omega}{(4 + j20) \Omega + (4 + j20) \times 10^{10} \Omega}$
	$I_L = 3,854 \angle 137.1^\circ A$
The voltage, as measured by the relay on $Z_L$ (Figure 3), is the voltage drop from the sending-end source through the sending-end source impedance.	
Eq. (52)	$V_S = E_S - (Z_S \times I_L)$
	$V_S = 132,791 \angle 240^\circ V - [(2 + j10) \Omega \times 3,854 \angle 137.1^\circ A]$
	$V_S = 98,265 \angle -110.6^\circ V$
The impedance seen by the relay on $Z_L$ .	
Eq. (53)	$Z_{L-Relay} = \frac{V_S}{I_L}$
	$Z_{L-Relay} = \frac{98,265 \angle -110.6^\circ V}{3,854 \angle 137.1^\circ A}$
	$Z_{L-Relay} = -9.676 + j23.59 \Omega$





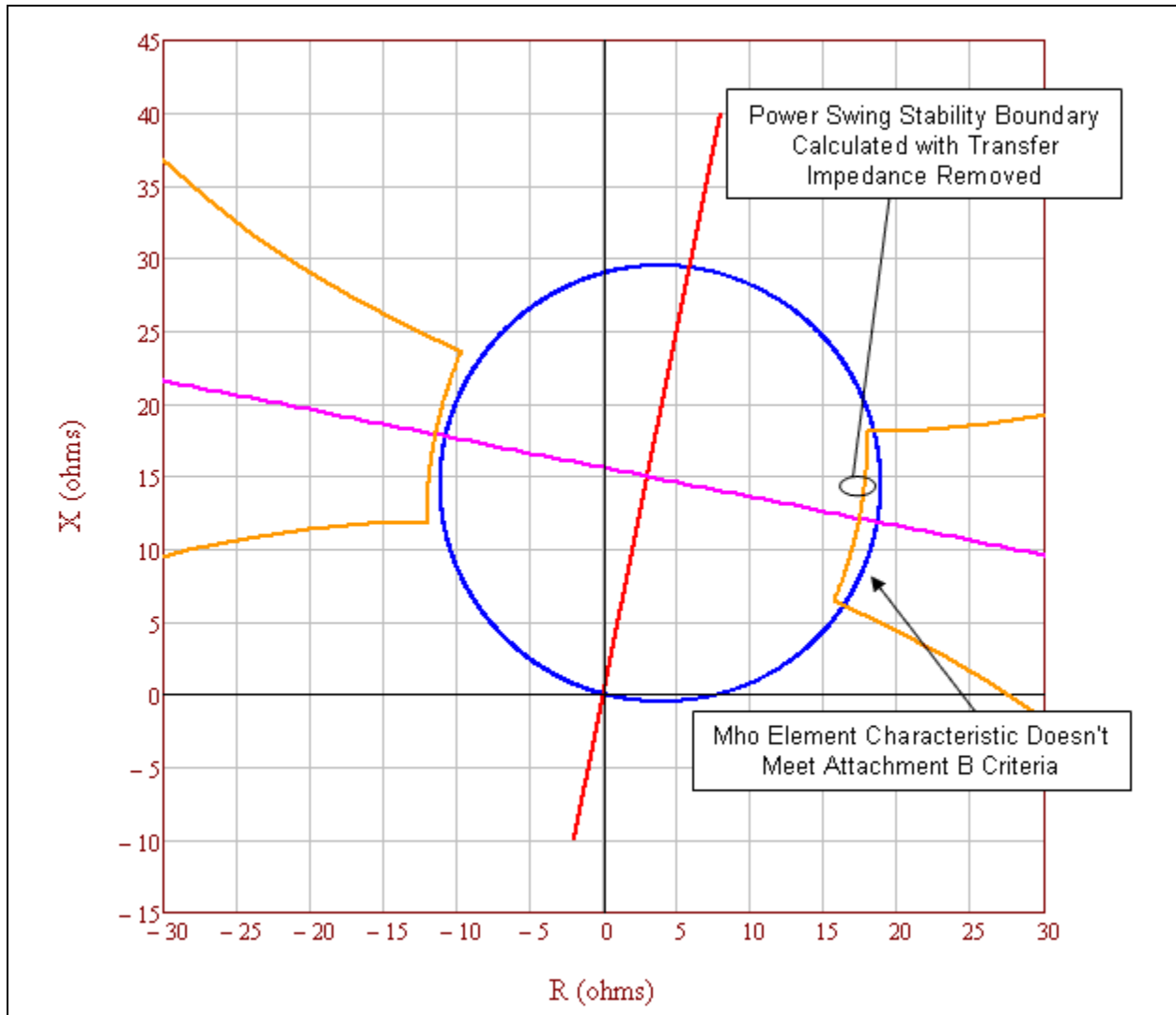
**Figure 8:** A strong-source system with a line impedance of  $Z_L = 20.4$  ohms (i.e., the thicker red line). This mho element characteristic (i.e., the blue circle) does not meet the PRC-026-2 – Attachment B, Criterion A because it is not completely contained within the unstable power swing region (i.e., the orange characteristic).

Figure 8 above represents a heavily-loaded system with all generation in service and all transmission BES Elements in their normal operating state. The mho element characteristic (set at 137% of  $Z_L$ ) extends into the unstable power swing region (i.e., the orange characteristic). Using the strongest source system is more conservative because it shrinks the unstable power swing region, bringing it closer to the mho element characteristic. This figure also graphically represents the effect of a system strengthening over time and this is the reason for re-evaluation if the relay has not been evaluated in the last five calendar years. Figure 9 below depicts a relay that meets the PRC-026-2 – Attachment B, Criterion A. Figure 8 depicts the same relay with the same setting five years later, where each source has strengthened by about 10% and now the same mho element characteristic does not meet Criterion A.



**Figure 9:** A weak-source system with a line impedance of  $Z_L = 20.4$  ohms (i.e., the thicker red line). This mho element characteristic (i.e., the blue circle) meets the PRC-026-2 – Attachment B, Criterion A because it is completely contained within the unstable power swing region (i.e., the orange characteristic).

Figure 9 above represents a lightly-loaded system, using a minimum generation profile. The mho element characteristic (set at 137% of  $Z_L$ ) does not extend into the unstable power swing region (i.e., the orange characteristic). Using a weaker source system expands the unstable power swing region away from the mho element characteristic.



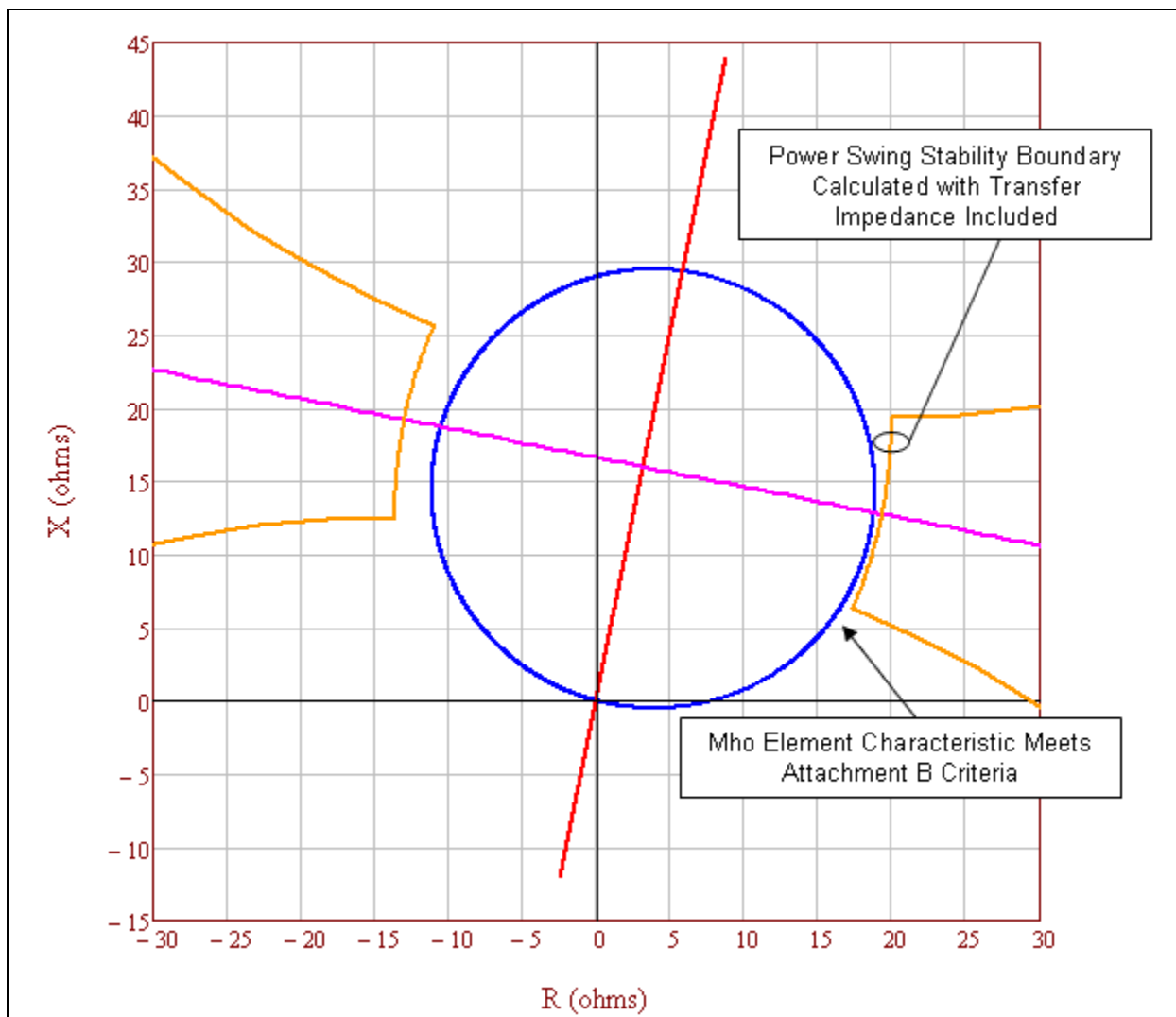
**Figure 10:** This is an example of an unstable power swing region (i.e., the orange characteristic) with the parallel transfer impedance removed. This relay mho element characteristic (i.e., the blue circle) does not meet PRC-026-2 – Attachment B, Criterion A because it is not completely contained within the unstable power swing region.

Table 8: Example Calculation (Parallel Transfer Impedance Removed)	
Calculations for the point at 120 degrees with equal source impedances. The total system current equals the line current. See Figure 10.	
Eq. (54)	$E_S = \frac{V_{LL} \angle 120^\circ}{\sqrt{3}}$
	$E_S = \frac{230,000 \angle 120^\circ V}{\sqrt{3}}$
	$E_S = 132,791 \angle 120^\circ V$



Table 8: Example Calculation (Parallel Transfer Impedance Removed)			
Eq. (55)	$E_R = \frac{V_{LL} \angle 0^\circ}{\sqrt{3}}$		
	$E_R = \frac{230,000 \angle 0^\circ V}{\sqrt{3}}$		
	$E_R = 132,791 \angle 0^\circ V$		
Given impedance data.			
Given:	$Z_S = 2 + j10 \Omega$	$Z_L = 4 + j20 \Omega$	$Z_R = 4 + j20 \Omega$
Given:	$Z_{TR} = Z_L \times 10^{10} \Omega$		
Total impedance between the generators.			
Eq. (56)	$Z_{total} = \frac{(Z_L \times Z_{TR})}{(Z_L + Z_{TR})}$		
	$Z_{total} = \frac{(4 + j20) \Omega \times (4 + j20) \times 10^{10} \Omega}{(4 + j20) \Omega + (4 + j20) \times 10^{10} \Omega}$		
	$Z_{total} = 4 + j20 \Omega$		
Total system impedance.			
Eq. (57)	$Z_{sys} = Z_S + Z_{total} + Z_R$		
	$Z_{sys} = (2 + j10) \Omega + (4 + j20) \Omega + (4 + j20) \Omega$		
	$Z_{sys} = 10 + j50 \Omega$		
Total system current from sending-end source.			
Eq. (58)	$I_{sys} = \frac{E_S - E_R}{Z_{sys}}$		
	$I_{sys} = \frac{132,791 \angle 120^\circ V - 132,791 \angle 0^\circ V}{10 + j50 \Omega}$		
	$I_{sys} = 4,511 \angle 71.3^\circ A$		
The current, as measured by the relay on $Z_L$ (Figure 3), is only the current flowing through that line as determined by using the current divider equation.			
Eq. (59)	$I_L = I_{sys} \times \frac{Z_{TR}}{Z_L + Z_{TR}}$		
	$I_L = 4,511 \angle 71.3^\circ A \times \frac{(4 + j20) \times 10^{10} \Omega}{(4 + j20) \Omega + (4 + j20) \times 10^{10} \Omega}$		
	$I_L = 4,511 \angle 71.3^\circ A$		

<b>Table 8: Example Calculation (Parallel Transfer Impedance Removed)</b>	
The voltage, as measured by the relay on $Z_L$ (Figure 3), is the voltage drop from the sending-end source through the sending-end source impedance.	
Eq. (60)	$V_S = E_S - (Z_S \times I_{sys})$
	$V_S = 132,791 \angle 120^\circ V - [(2 + j10 \Omega) \times 4,511 \angle 71.3^\circ A]$
	$V_S = 95,757 \angle 106.1^\circ V$
The impedance seen by the relay on $Z_L$ .	
Eq. (61)	$Z_{L-Relay} = \frac{V_S}{I_L}$
	$Z_{L-Relay} = \frac{95,757 \angle 106.1^\circ V}{4,511 \angle 71.3^\circ A}$
	$Z_{L-Relay} = 17.434 + j12.113 \Omega$



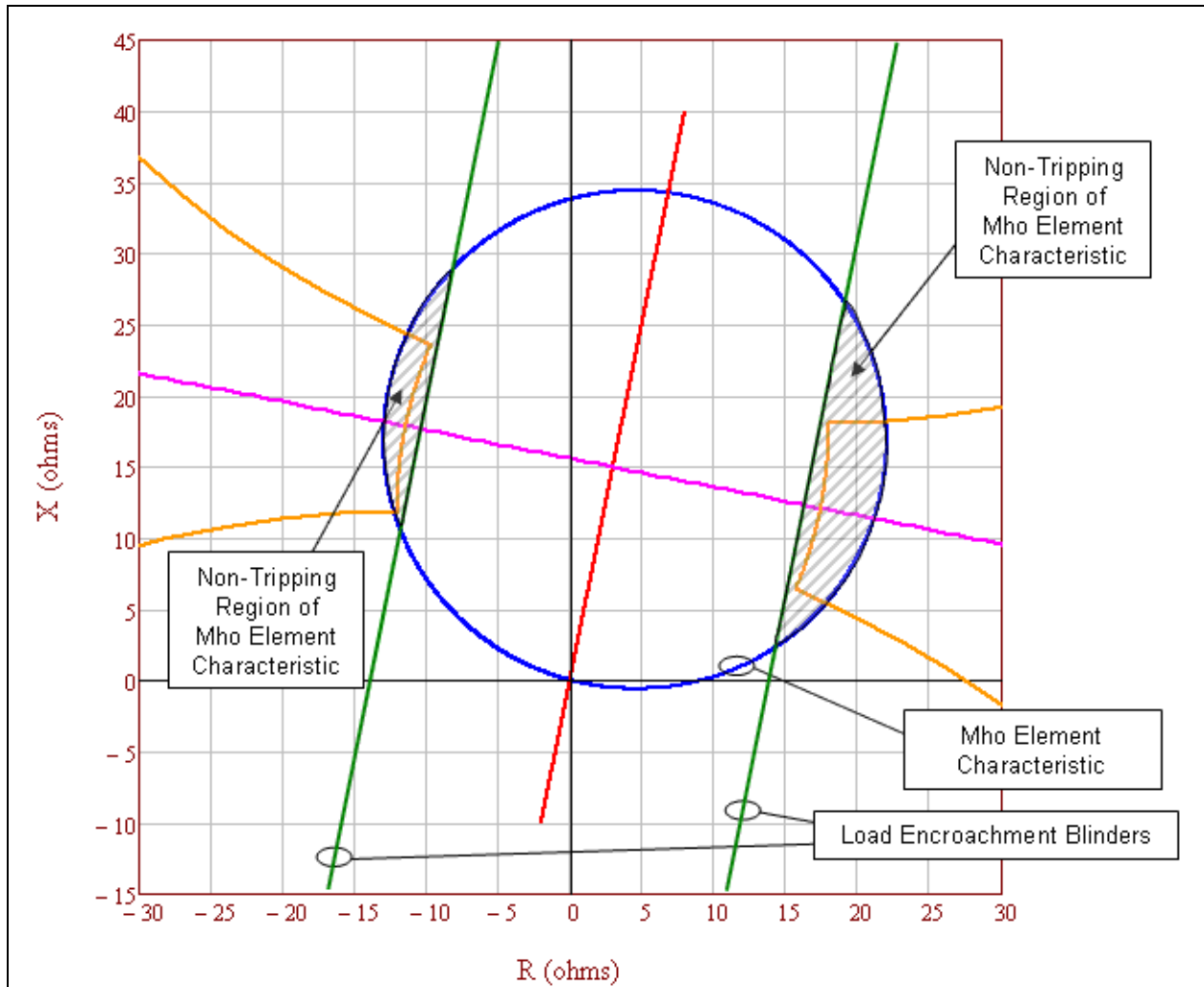
**Figure 11:** This is an example of an unstable power swing region (i.e., the orange characteristic) with the parallel transfer impedance included causing the mho element characteristic (i.e., the blue circle) to appear to meet the PRC-026-2 – Attachment B, Criterion A because it is completely contained within the unstable power swing region. Including the parallel transfer impedance in the calculation is not allowed by the PRC-026-2 – Attachment B, Criterion A.

In Figure 11 above, the parallel transfer impedance is 5 times the line impedance. The unstable power swing region has expanded out beyond the mho element characteristic due to the infeed effect from the parallel current through the parallel transfer impedance, thus allowing the mho element characteristic to appear to meet the PRC-026-2 – Attachment B, Criterion A. Including the parallel transfer impedance in the calculation is not allowed by the PRC-026-2 – Attachment B, Criterion A.

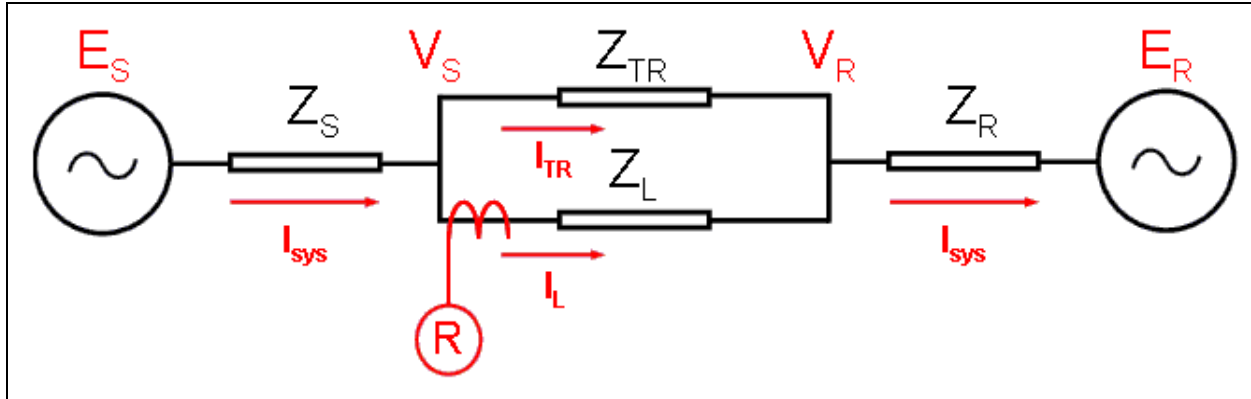
Table 9: Example Calculation (Parallel Transfer Impedance Included)			
Calculations for the point at 120 degrees with equal source impedances. The total system current does not equal the line current. See Figure 11.			
Eq. (62)	$E_S = \frac{V_{LL} \angle 120^\circ}{\sqrt{3}}$		
	$E_S = \frac{230,000 \angle 120^\circ V}{\sqrt{3}}$		
	$E_S = 132,791 \angle 120^\circ V$		
Eq. (63)	$E_R = \frac{V_{LL} \angle 0^\circ}{\sqrt{3}}$		
	$E_R = \frac{230,000 \angle 0^\circ V}{\sqrt{3}}$		
	$E_R = 132,791 \angle 0^\circ V$		
Given impedance data.			
Given:	$Z_S = 2 + j10 \Omega$	$Z_L = 4 + j20 \Omega$	$Z_R = 4 + j20 \Omega$
Given:	$Z_{TR} = Z_L \times 5$		
	$Z_{TR} = (4 + j20) \Omega \times 5$		
	$Z_{TR} = 20 + j100 \Omega$		
Total impedance between the generators.			
Eq. (64)	$Z_{total} = \frac{(Z_L \times Z_{TR})}{(Z_L + Z_{TR})}$		
	$Z_{total} = \frac{(4 + j20) \Omega \times (20 + j100) \Omega}{(4 + j20) \Omega + (20 + j100) \Omega}$		
	$Z_{total} = 3.333 + j16.667 \Omega$		
Total system impedance.			
Eq. (65)	$Z_{sys} = Z_S + Z_{total} + Z_R$		
	$Z_{sys} = (2 + j10) \Omega + (3.333 + j16.667) \Omega + (4 + j20) \Omega$		
	$Z_{sys} = 9.333 + j46.667 \Omega$		
Total system current from sending-end source.			
Eq. (66)	$I_{sys} = \frac{E_S - E_R}{Z_{sys}}$		
	$I_{sys} = \frac{132,791 \angle 120^\circ V - 132,791 \angle 0^\circ V}{9.333 + j46.667 \Omega}$		

Table 9: Example Calculation (Parallel Transfer Impedance Included)	
	$I_{sys} = 4,833 \angle 71.3^\circ A$
The current, as measured by the relay on $Z_L$ (Figure 3), is only the current flowing through that line as determined by using the current divider equation.	
Eq. (67)	$I_L = I_{sys} \times \frac{Z_{TR}}{Z_L + Z_{TR}}$
	$I_L = 4,833 \angle 71.3^\circ A \times \frac{(20 + j100) \Omega}{(4 + j20) \Omega + (20 + j100) \Omega}$
	$I_L = 4,027.4 \angle 71.3^\circ A$
The voltage, as measured by the relay on $Z_L$ (Figure 3), is the voltage drop from the sending-end source through the sending-end source impedance.	
Eq. (68)	$V_S = E_S - (Z_S \times I_{sys})$
	$V_S = 132,791 \angle 120^\circ V - [(2 + j10) \Omega \times 4,833 \angle 71.3^\circ A]$
	$V_S = 93,417 \angle 104.7^\circ V$
The impedance seen by the relay on $Z_L$ .	
Eq. (69)	$Z_{L-Relay} = \frac{V_S}{I_L}$
	$Z_{L-Relay} = \frac{93,417 \angle 104.7^\circ V}{4,027 \angle 71.3^\circ A}$
	$Z_{L-Relay} = 19.366 + j12.767 \Omega$

<b>Table 10: Percent Increase of a Lens Due To Parallel Transfer Impedance.</b>	
The following demonstrates the percent size increase of the lens characteristic for $Z_{TR}$ in multiples of $Z_L$ with the parallel transfer impedance included.	
$Z_{TR}$ in multiples of $Z_L$	Percent increase of lens with equal EMF sources (Infinite source as reference)
Infinite	N/A
1000	0.05%
100	0.46%
10	4.63%
5	9.27%
2	23.26%
1	46.76%
0.5	94.14%
0.25	189.56%



**Figure 12:** The tripping portion of the mho element characteristic (i.e., the blue circle) not blocked by load encroachment (i.e., the parallel green lines) is completely contained within the unstable power swing region (i.e., the orange characteristic). Therefore, the mho element characteristic meets the PRC-026-2– Attachment B, Criterion A.



**Figure 13:** The infeed diagram shows the impedance in front of the relay R with the parallel transfer impedance included. As the parallel transfer impedance approaches infinity, the impedances seen by the relay R in the forward direction becomes  $Z_L + Z_R$ .

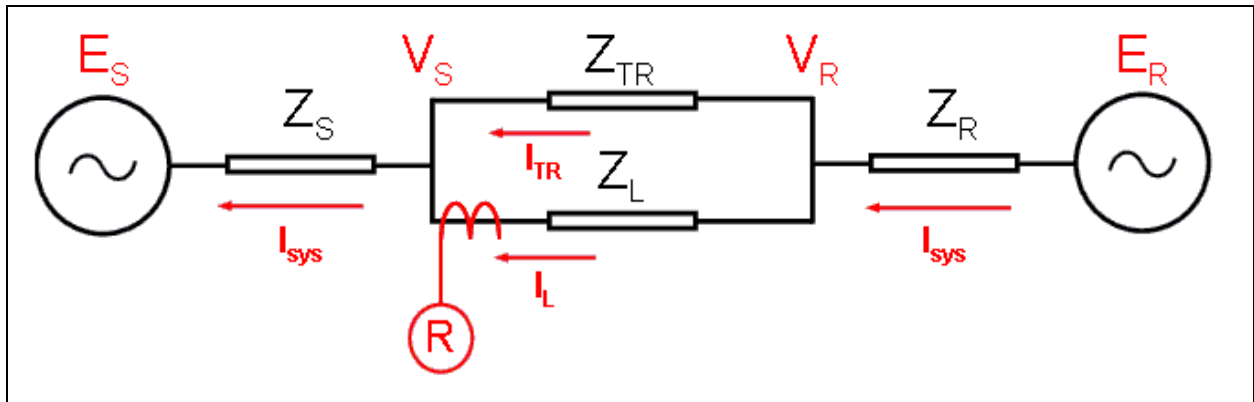
**Table 11: Calculations (System Apparent Impedance in the forward direction)**

The following equations are provided for calculating the apparent impedance back to the  $E_R$  source voltage as seen by relay R. Infeed equations from  $V_S$  to source  $E_R$  where  $E_R = 0$ . See Figure 13.

Eq. (70)	$I_L = \frac{V_S - V_R}{Z_L}$			
Eq. (71)	$I_{sys} = \frac{V_R - E_R}{Z_R}$			
Eq. (72)	$I_{sys} = I_L + I_{TR}$			
Eq. (73)	$I_{sys} = \frac{V_R}{Z_R}$	Since $E_R = 0$	Rearranged:	$V_R = I_{sys} \times Z_R$
Eq. (74)	$I_L = \frac{V_S - I_{sys} \times Z_R}{Z_L}$			
Eq. (75)	$I_L = \frac{V_S - [(I_L + I_{TR}) \times Z_R]}{Z_L}$			
Eq. (76)	$V_S = (I_L \times Z_L) + (I_L \times Z_R) + (I_{TR} \times Z_R)$			
Eq. (77)	$Z_{Relay} = \frac{V_S}{I_L} = Z_L + Z_R + \frac{I_{TR} \times Z_R}{I_L} = Z_L + Z_R \times \left(1 + \frac{I_{TR}}{I_L}\right)$			
Eq. (78)	$I_{TR} = I_{sys} \times \frac{Z_L}{Z_L + Z_{TR}}$			
Eq. (79)	$I_L = I_{sys} \times \frac{Z_{TR}}{Z_L + Z_{TR}}$			



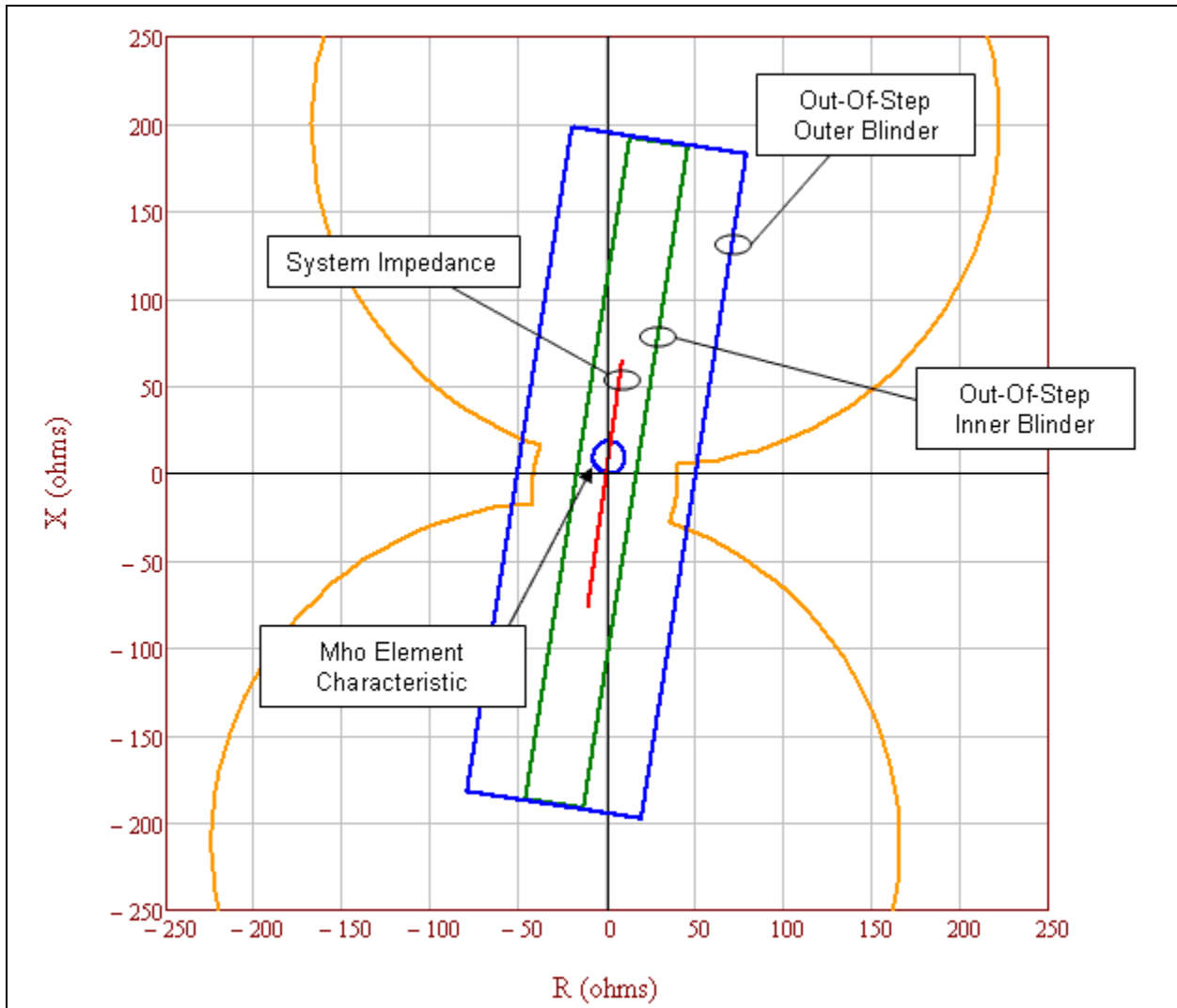
Table 11: Calculations (System Apparent Impedance in the forward direction)	
Eq. (80)	$\frac{I_{TR}}{I_L} = \frac{Z_L}{Z_{TR}}$
The infeed equations shows the impedance in front of the relay R (Figure 13) with the parallel transfer impedance included. As the parallel transfer impedance approaches infinity, the impedances seen by the relay R in the forward direction becomes $Z_L + Z_R$ .	
Eq. (81)	$Z_{Relay} = Z_L + Z_R \times \left(1 + \frac{Z_L}{Z_{TR}}\right)$



**Figure 14:** The infeed diagram shows the impedance behind relay R with the parallel transfer impedance included. As the parallel transfer impedance approaches infinity, the impedances seen by the relay R in the reverse direction becomes  $Z_S$ .

Table 12: Calculations (System Apparent Impedance in the Reverse Direction)				
The following equations are provided for calculating the apparent impedance back to the $E_S$ source voltage as seen by relay R. Infeed equations from $V_R$ back to source $E_S$ where $E_S = 0$ . See Figure 14.				
Eq. (82)	$I_L = \frac{V_R - V_S}{Z_L}$			
Eq. (83)	$I_{sys} = \frac{V_S - E_S}{Z_S}$			
Eq. (84)	$I_{sys} = I_L + I_{TR}$			
Eq. (85)	$I_{sys} = \frac{V_S}{Z_S}$	Since $E_S = 0$	Rearranged:	$V_S = I_{sys} \times Z_S$
Eq. (86)	$I_L = \frac{V_R - I_{sys} \times Z_S}{Z_L}$			

Table 12: Calculations (System Apparent Impedance in the Reverse Direction)		
Eq. (87)	$I_L = \frac{V_R - [(I_L + I_{TR}) \times Z_S]}{Z_L}$	
Eq. (88)	$V_R = (I_L \times Z_L) + (I_L \times Z_S) + (I_{TR} \times Z_{RS})$	
Eq. (89)	$Z_{Relay} = \frac{V_R}{I_L} = Z_L + Z_S + \frac{I_{TR} \times Z_S}{I_L} = Z_L + Z_S \times \left(1 + \frac{I_{TR}}{I_L}\right)$	
Eq. (90)	$I_{TR} = I_{sys} \times \frac{Z_L}{Z_L + Z_{TR}}$	
Eq. (91)	$I_L = I_{sys} \times \frac{Z_{TR}}{Z_L + Z_{TR}}$	
Eq. (92)	$\frac{I_{TR}}{I_L} = \frac{Z_L}{Z_{TR}}$	
The infeed equations shows the impedance behind relay R (Figure 14) with the parallel transfer impedance included. As the parallel transfer impedance approaches infinity, the impedances seen by the relay R in the reverse direction becomes $Z_S$ .		
Eq. (93)	$Z_{Relay} = Z_L + Z_S \times \left(1 + \frac{Z_L}{Z_{TR}}\right)$	As seen by relay R at the receiving-end of the line.
Eq. (94)	$Z_{Relay} = Z_S \times \left(1 + \frac{Z_L}{Z_{TR}}\right)$	Subtract $Z_L$ for relay R impedance as seen at sending-end of the line.



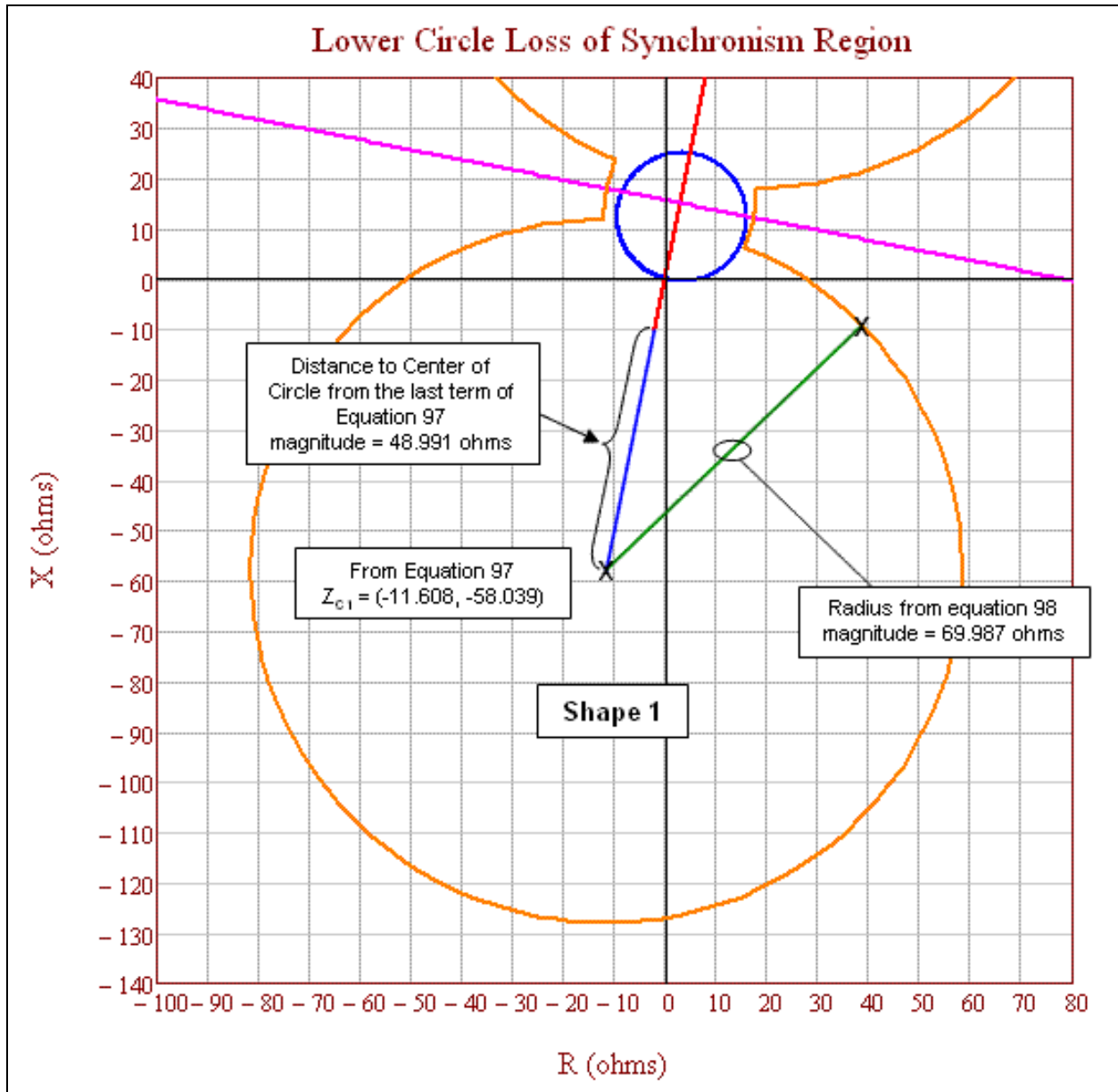
**Figure 15:** Out-of-step trip (OST) inner blinder (i.e., the parallel green lines) meets the PRC-026-2 – Attachment B, Criterion A because the inner OST blinder initiates tripping either On-The-Way-In or On-The-Way-Out. Since the inner blinder is completely contained within the unstable power swing region (i.e., the orange characteristic), it meets the PRC-026-2 – Attachment B, Criterion A.

**Table 13: Example Calculation (Voltage Ratios)**

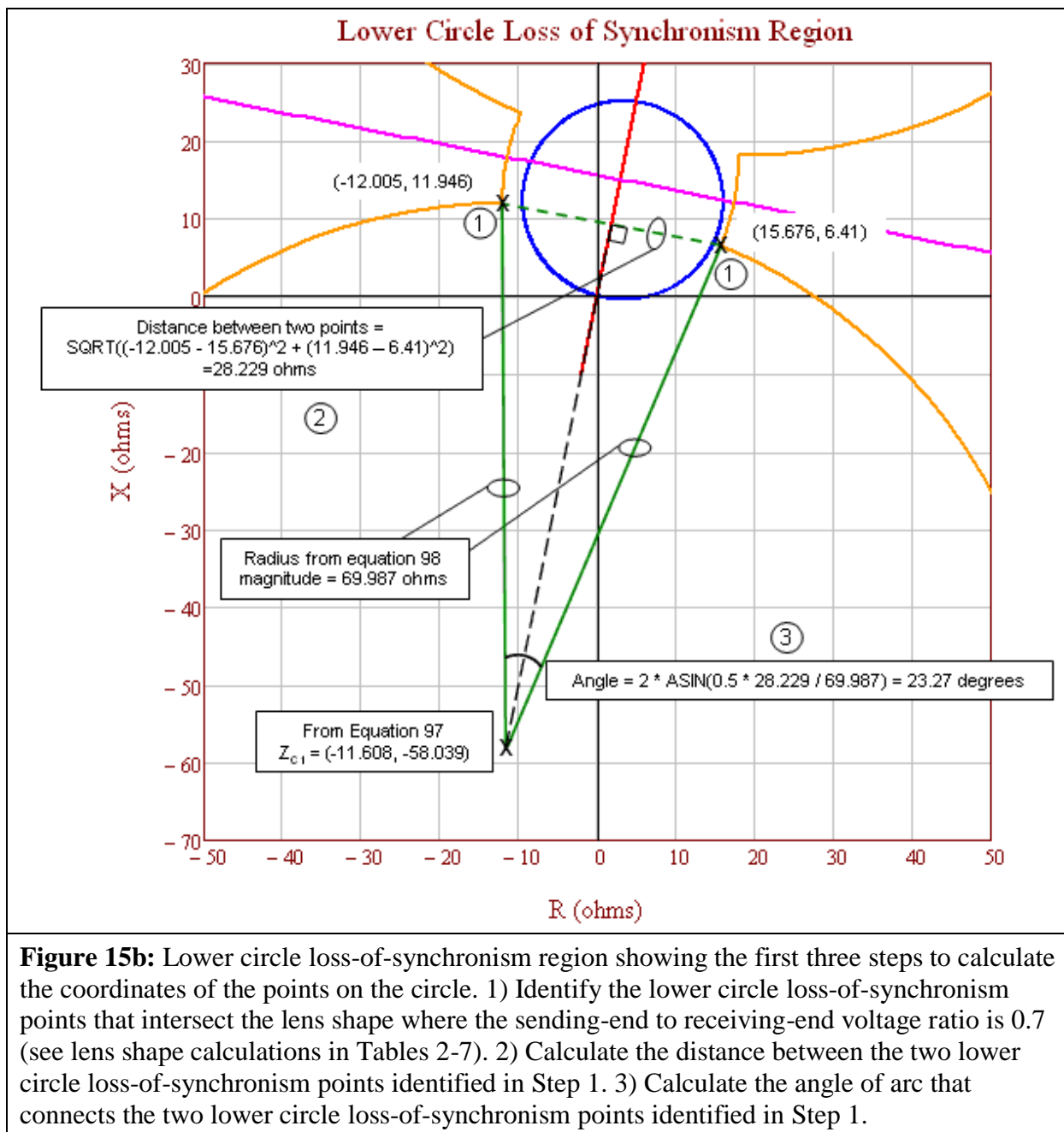
These calculations are based on the loss-of-synchronism characteristics for the cases of $N < 1$ and $N > 1$ as found in the <i>Application of Out-of-Step Blocking and Tripping Relays</i> , GER-3180, p. 12, Figure 3. <sup>17</sup> The GE illustration shows the formulae used to calculate the radius and center of the circles that make up the ends of the portion of the lens.			
Voltage ratio equations, source impedance equation with infeed formulae applied, and circle equations.			
Given:	$E_S = 0.7$	$E_R = 1.0$	
Eq. (95)	$N = \frac{ E_S }{ E_R } = \frac{0.7}{1.0} = 0.7$		
The total system impedance as seen by the relay with infeed formulae applied.			
Given:	$Z_S = 2 + j10 \Omega$	$Z_L = 4 + j20 \Omega$	$Z_R = 4 + j20 \Omega$
Given:	$Z_{TR} = Z_L \times 10^{10} \Omega$		
	$Z_{TR} = (4 + j20) \times 10^{10} \Omega$		
Eq. (96)	$Z_{sys} = Z_S \times \left(1 + \frac{Z_L}{Z_{TR}}\right) + \left[Z_L + Z_R \times \left(1 + \frac{Z_L}{Z_{TR}}\right)\right]$		
	$Z_{sys} = 10 + j50 \Omega$		
The calculated coordinates of the lower loss-of-synchronism circle center.			
Eq. (97)	$Z_{C1} = - \left[ Z_S \times \left(1 + \frac{Z_L}{Z_{TR}}\right) \right] - \left[ \frac{N^2 \times Z_{sys}}{1 - N^2} \right]$		
	$Z_{C1} = - \left[ (2 + j10) \Omega \times \left(1 + \frac{(4 + j20) \Omega}{(4 + j20) \times 10^{10} \Omega}\right) \right] - \left[ \frac{0.7^2 \times (10 + j50) \Omega}{1 - 0.7^2} \right]$		
	$Z_{C1} = -11.608 - j58.039 \Omega$		
The calculated radius of the lower loss-of-synchronism circle.			
Eq. (98)	$r_a = \left  \frac{N \times Z_{sys}}{1 - N^2} \right $		
	$r_a = \left  \frac{0.7 \times (10 + j50) \Omega}{1 - 0.7^2} \right $		
	$r_a = 69.987 \Omega$		
The calculated coordinates of the upper loss-of-synchronism circle center.			
Given:	$E_S = 1.0$	$E_R = 0.7$	

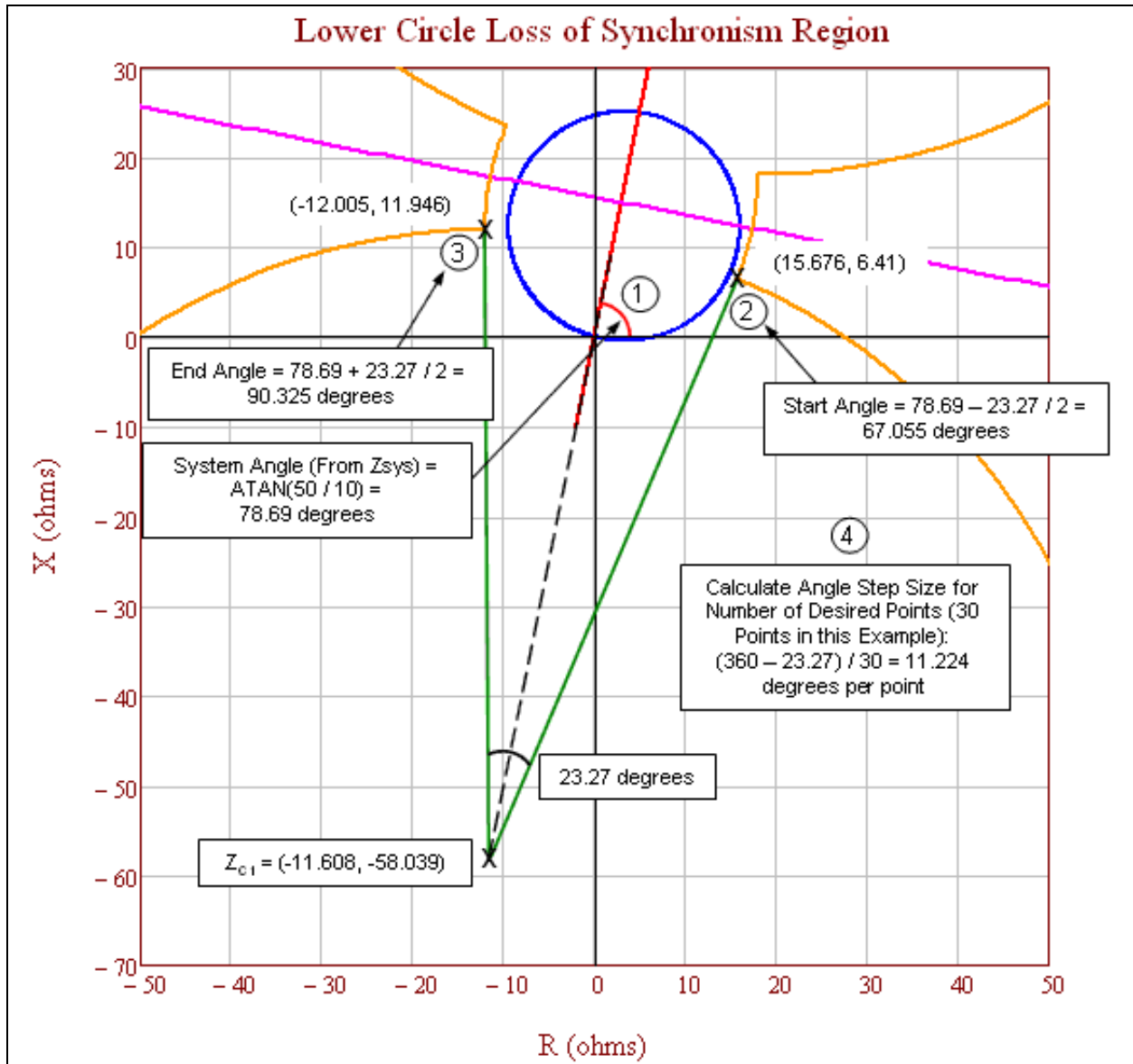
<sup>17</sup> <http://store.gedigitalenergy.com/faq/Documents/Alps/GER-3180.pdf>

Table 13: Example Calculation (Voltage Ratios)	
Eq. (99)	$N = \frac{ E_S }{ E_R } = \frac{1.0}{0.7} = 1.43$
Eq. (100)	$Z_{C2} = Z_L + \left[ Z_R \times \left( 1 + \frac{Z_L}{Z_{TR}} \right) \right] + \left[ \frac{Z_{sys}}{N^2 - 1} \right]$
	$Z_{C2} = 4 + j20 \Omega + \left[ (4 + j20) \Omega \times \left( 1 + \frac{(4 + j20) \Omega}{(4 + j20) \times 10^{10} \Omega} \right) \right] + \left[ \frac{(10 + j50) \Omega}{1.43^2 - 1} \right]$
	$Z_{C2} = 17.608 + j88.039 \Omega$
The calculated radius of the upper loss-of-synchronism circle.	
Eq. (101)	$r_b = \left  \frac{N \times Z_{sys}}{N^2 - 1} \right $
	$r_b = \left  \frac{1.43 \times (10 + j50) \Omega}{1.43^2 - 1} \right $
	$r_b = 69.987 \Omega$



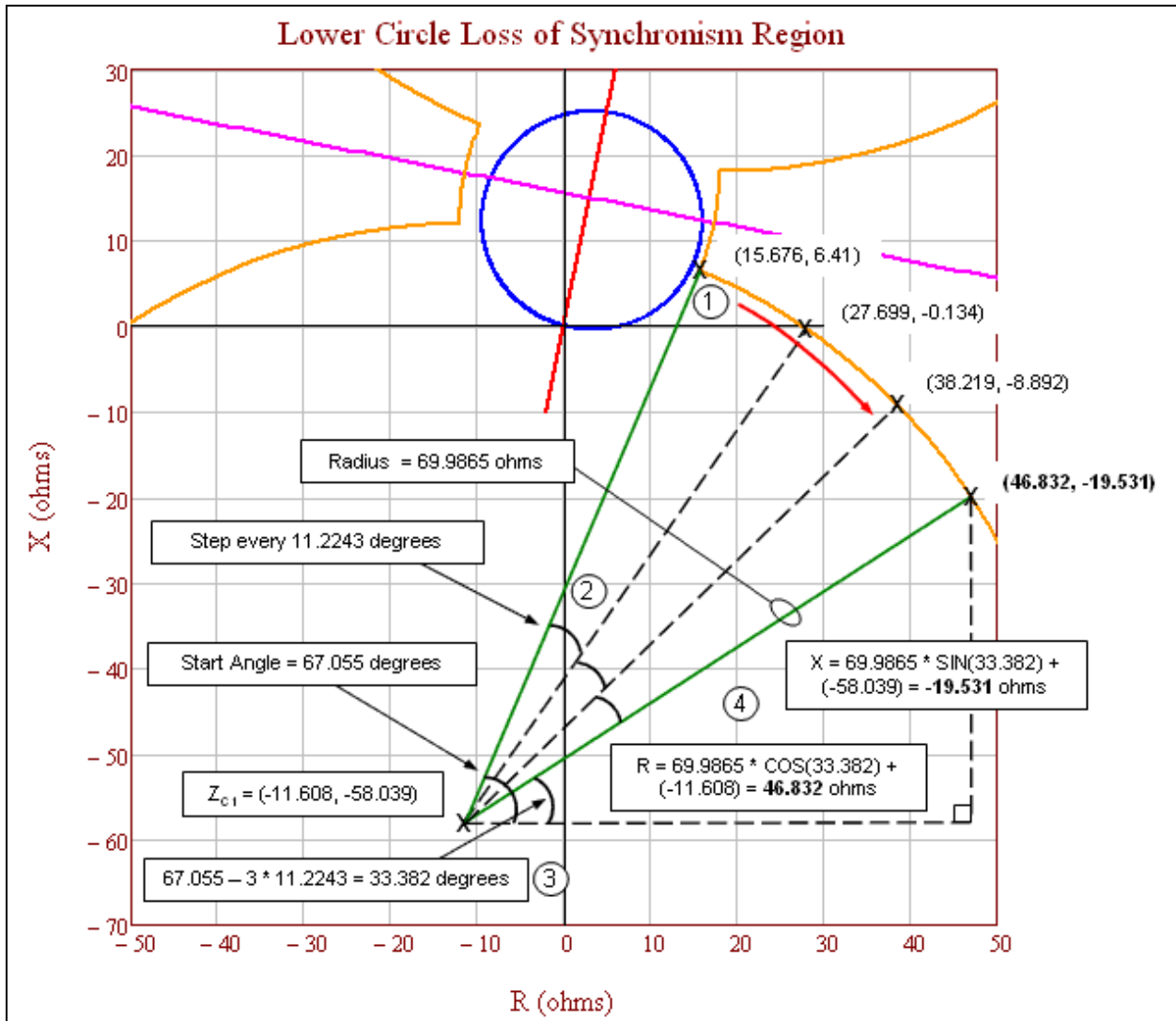
**Figure 15a:** Lower circle loss-of-synchronism region showing the coordinates of the circle center and the circle radius.



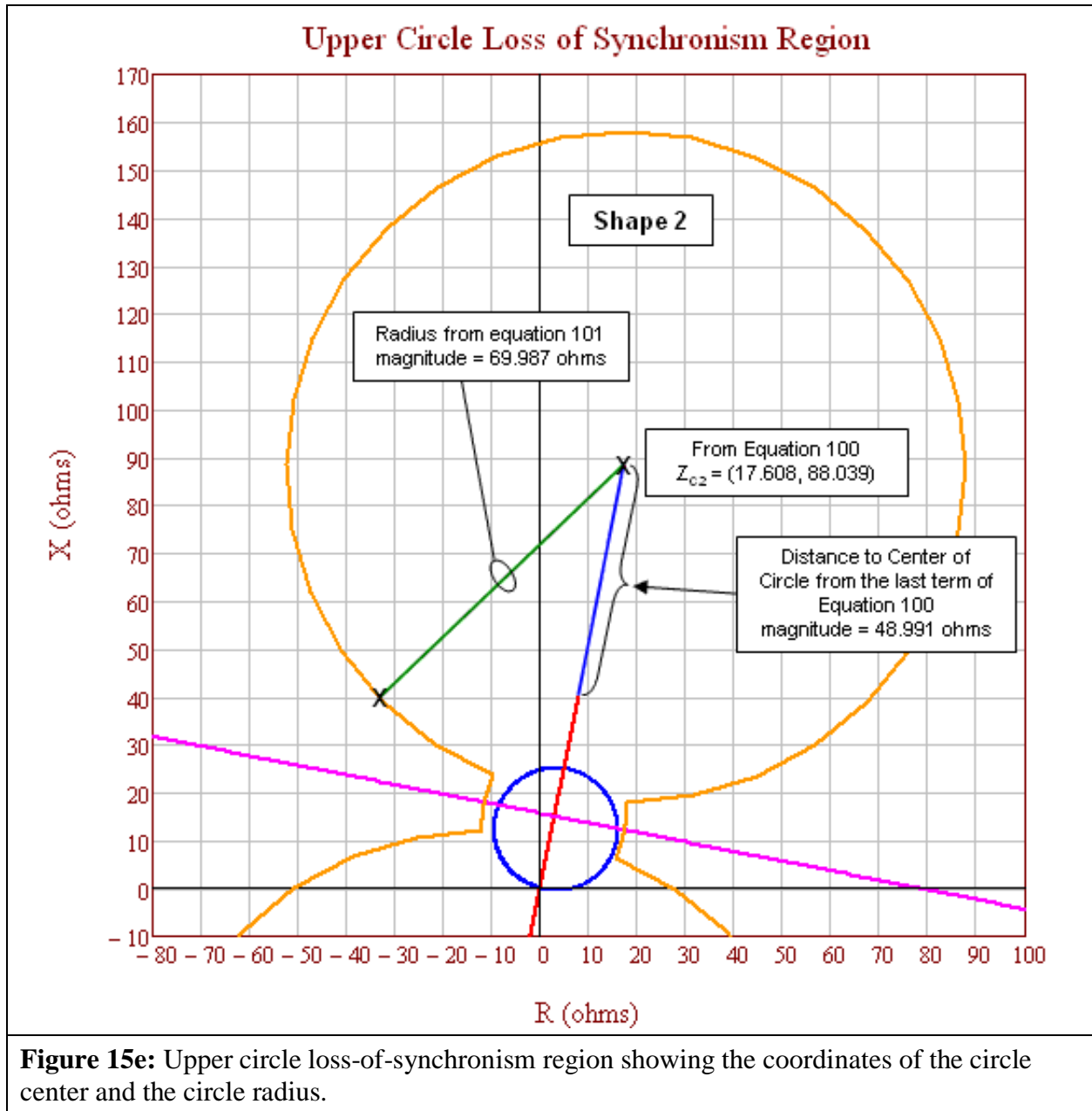


**Figure 15c:** Lower circle loss-of-synchronism region showing the steps to calculate the start angle, end angle, and the angle step size for the desired number of calculated points. 1) Calculate the system angle. 2) Calculate the start angle. 3) Calculate the end angle. 4) Calculate the angle step size for the desired number of points.

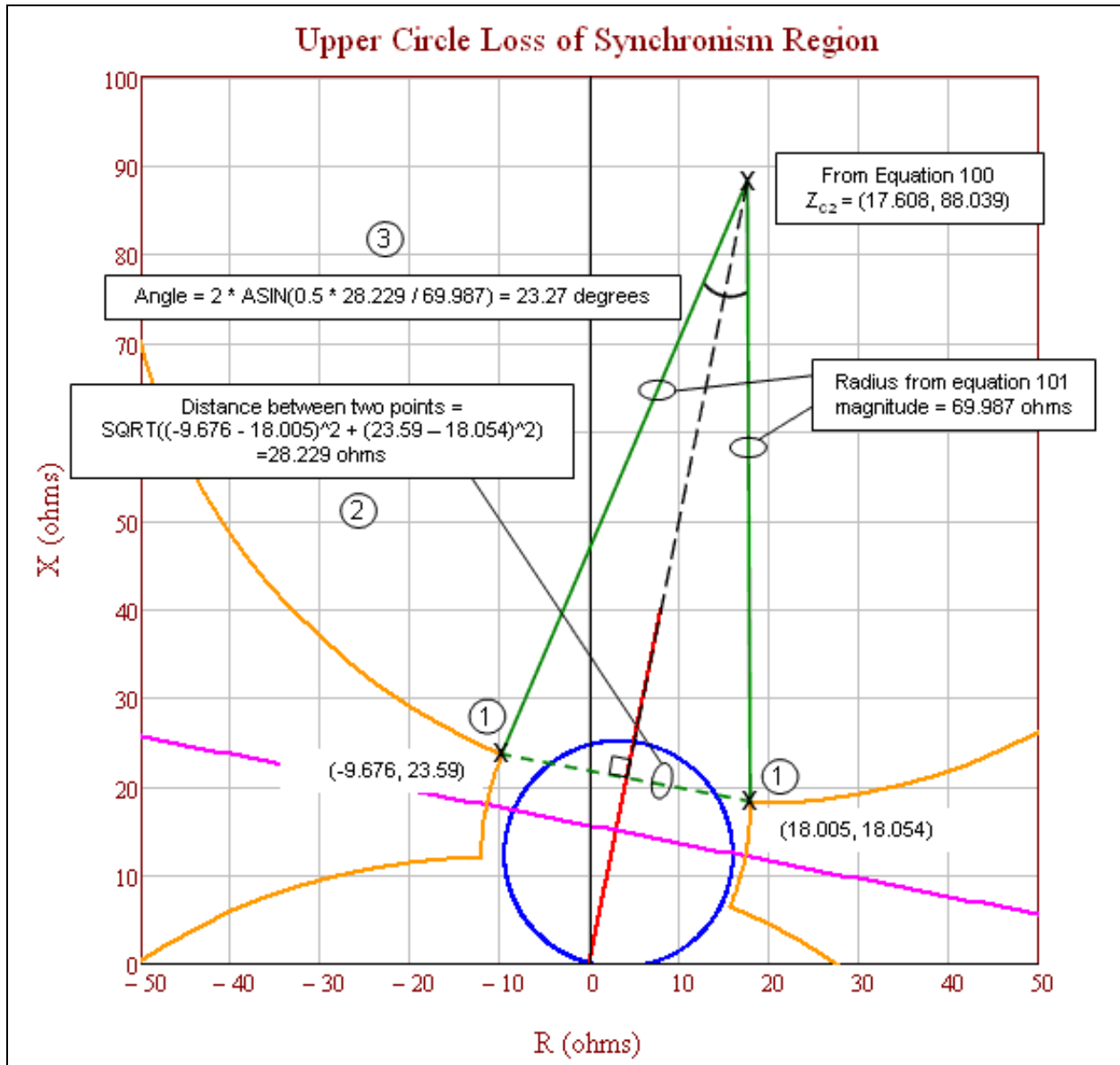




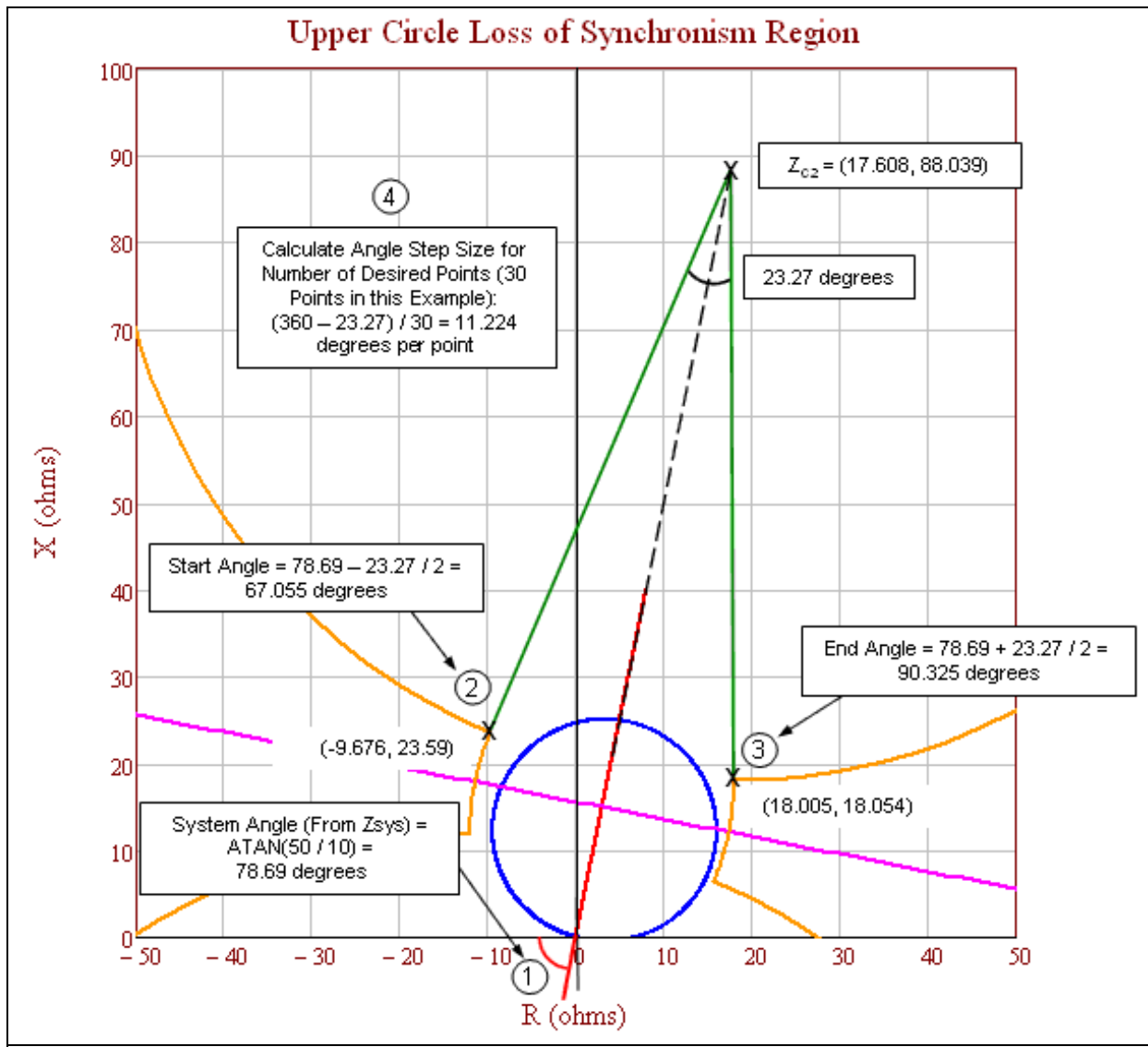
**Figure 15d:** Lower circle loss-of-synchronism region showing the final steps to calculate the coordinates of the points on the circle. 1) Start at the intersection with the lens shape and proceed in a clockwise direction. 2) Advance the step angle for each point. 3) Calculate the new angle after step advancement. 4) Calculate the R–X coordinates.



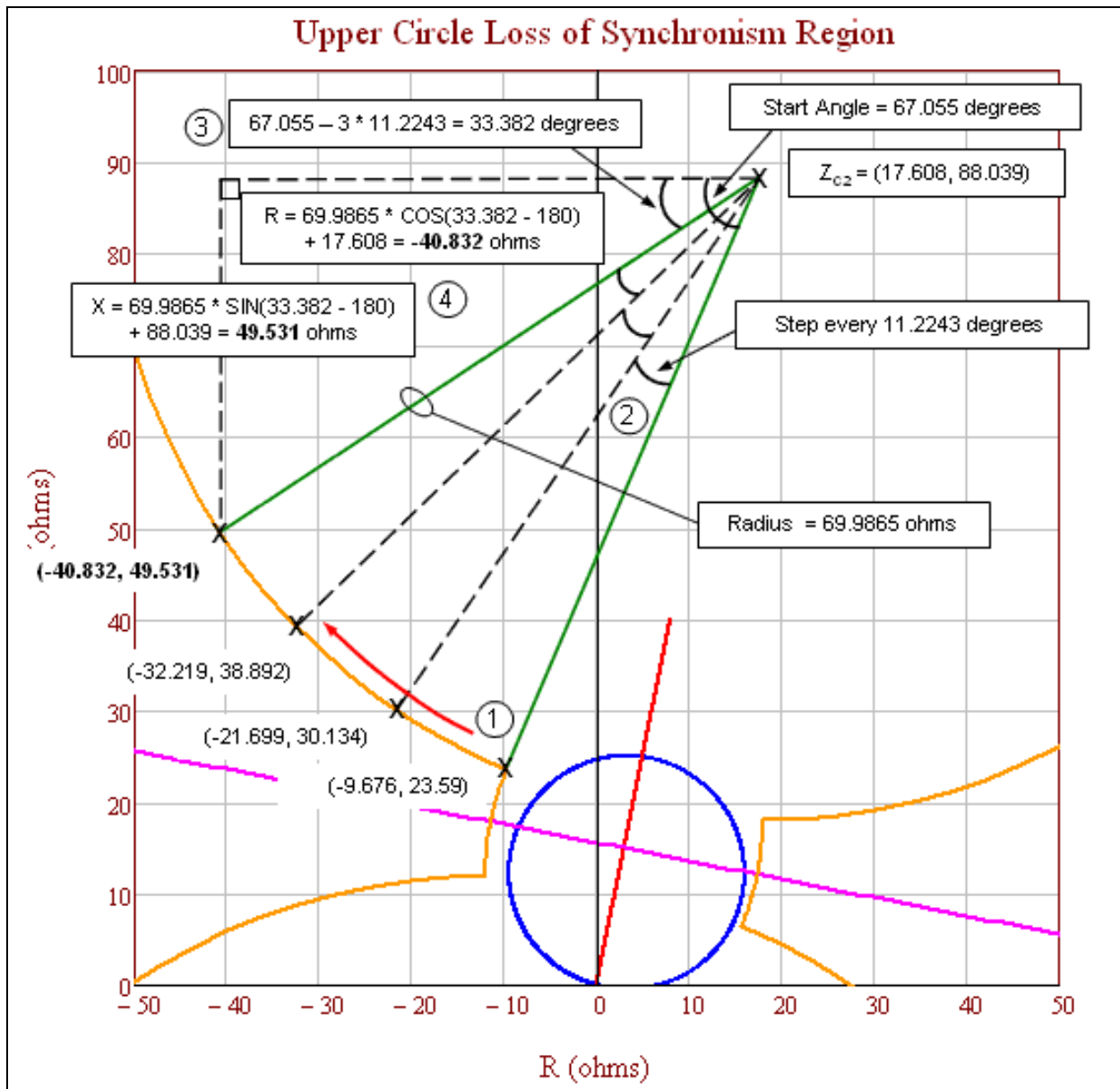
**Figure 15e:** Upper circle loss-of-synchronism region showing the coordinates of the circle center and the circle radius.



**Figure 15f:** Upper circle loss-of-synchronism region showing the first three steps to calculate the coordinates of the points on the circle. 1) Identify the upper circle points that intersect the lens shape where the sending-end to receiving-end voltage ratio is 1.43 (see lens shape calculations in Tables 2-7). 2) Calculate the distance between the two upper circle points identified in Step 1. 3) Calculate the angle of arc that connects the two upper circle points identified in Step 1.



**Figure 15g:** Upper circle loss-of-synchronism region showing the steps to calculate the start angle, end angle, and the angle step size for the desired number of calculated points. 1) Calculate the system angle. 2) Calculate the start angle. 3) Calculate the end angle. 4) Calculate the angle step size for the desired number of points.



**Figure 15h:** Upper circle loss-of-synchronism region showing the final steps to calculate the coordinates of the points on the circle. 1) Start at the intersection with the lens shape and proceed in a clockwise direction. 2) Advance the step angle for each point. 3) Calculate the new angle after step advancement. 4) Calculate the R-X coordinates.

Lower Loss of Synchronism Circle Coordinates			Upper Loss of Synchronism Circle Coordinates		
Angle (degrees)	R	+ jX	Angle (degrees)	R	+ jX
67.055	15.676	6.41	67.055	-9.676	23.59
55.831	27.699	-0.134	55.831	-21.699	30.134
44.606	38.219	-8.892	44.606	-32.219	38.892
<b>33.382</b>	<b>46.832</b>	<b>-19.531</b>	<b>33.382</b>	<b>-40.832</b>	<b>49.531</b>
22.158	53.21	-31.643	22.158	-47.21	61.643
10.933	57.108	-44.765	10.933	-51.108	74.765
359.709	58.378	-58.395	359.709	-52.378	88.395
348.485	56.97	-72.011	348.485	-50.97	102.011
337.26	52.939	-85.092	337.26	-46.939	115.092
326.036	46.438	-97.139	326.036	-40.438	127.139
314.812	37.717	-107.69	314.812	-31.717	137.69
303.587	27.109	-116.341	303.587	-21.109	146.341
292.363	15.02	-122.762	292.363	-9.02	152.762
281.139	1.913	-126.707	281.139	4.087	156.707
269.914	-11.712	-128.026	269.914	17.712	158.026
258.69	-25.333	-126.667	258.69	31.333	156.667
247.466	-38.429	-122.682	247.466	44.429	152.682
236.241	-50.499	-116.225	236.241	56.499	146.225
225.017	-61.081	-107.542	225.017	67.081	137.542
213.793	-69.771	-96.965	213.793	75.771	126.965
202.568	-76.235	-84.899	202.568	82.235	114.899
191.344	-80.227	-71.806	191.344	86.227	101.806
180.12	-81.594	-58.185	180.12	87.594	88.185
168.895	-80.284	-44.56	168.895	86.284	74.56
157.671	-76.347	-31.45	157.671	82.347	61.45
146.447	-69.933	-19.357	146.447	75.933	49.357
135.222	-61.288	-8.744	135.222	67.288	38.744
123.998	-50.742	-0.016	123.998	56.742	30.016
112.774	-38.699	6.491	112.774	44.699	23.509
101.549	-25.62	10.53	101.549	31.62	19.47
90.325	-12.005	11.946	90.325	18.005	18.054

**Figure 15i:** Full tables of calculated lower and upper loss-of-synchronism circle coordinates. The highlighted row is the detailed calculated points in Figures 15d and 15h.

### Application Specific to Criterion B

The PRC-026-2– Attachment B, Criterion B evaluates overcurrent elements used for tripping. The same criteria as PRC-026-2 – Attachment B, Criterion A is used except for an additional criterion (No. 4) that calculates a current magnitude based upon generator internal voltage of 1.05 per unit. A value of 1.05 per unit generator voltage is used to establish a minimum pickup current value for overcurrent relays that have a time delay less than 15 cycles. The sending-end and receiving-end voltages are established at 1.05 per unit at 120 degree system separation angle. The 1.05 per unit is the typical upper end of the operating voltage, which is also consistent with the maximum power

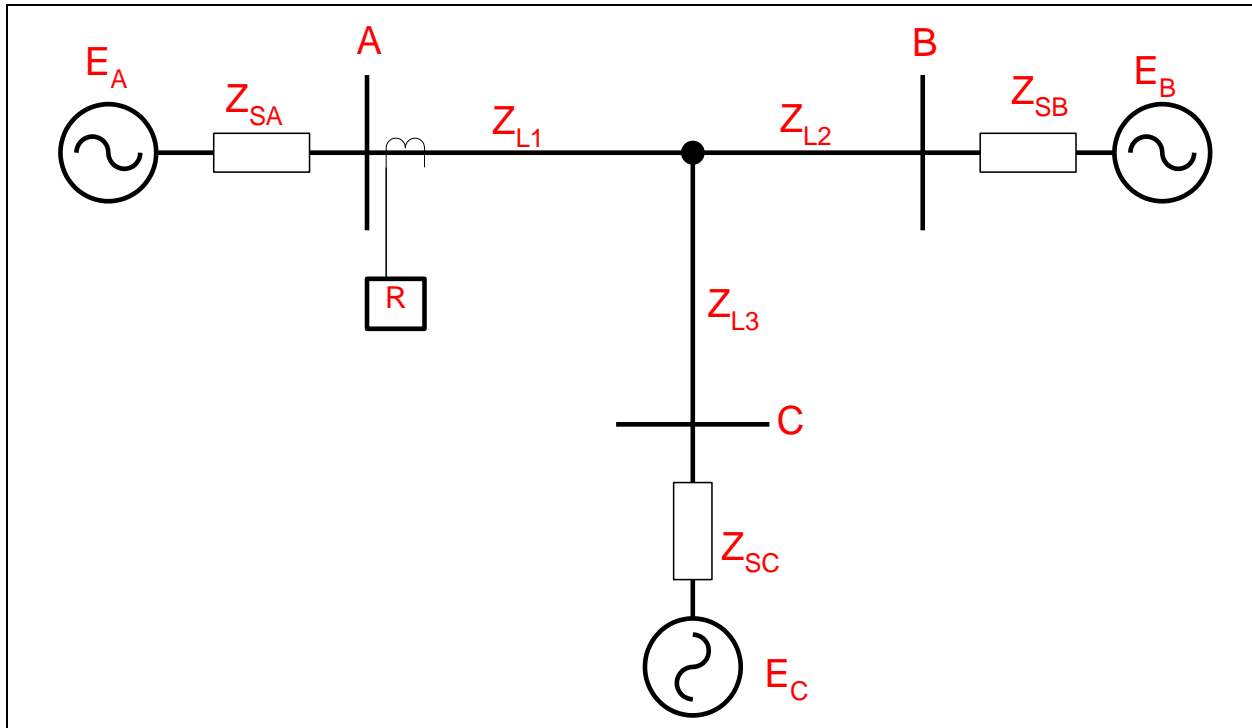
transfer calculation using actual system source impedances in the PRC-023 NERC Reliability Standard. The formulas used to calculate the current are in Table 14 below.

<b>Table 14: Example Calculation (Overcurrent)</b>			
<p>This example is for a 230 kV line terminal with a directional instantaneous phase overcurrent element set to 50 amps secondary times a CT ratio of 160:1 that equals 8,000 amps, primary. The following calculation is where <math>V_S</math> equals the base line-to-ground sending-end generator source voltage times 1.05 at an angle of 120 degrees, <math>V_R</math> equals the base line-to-ground receiving-end generator internal voltage times 1.05 at an angle of 0 degrees, and <math>Z_{sys}</math> equals the sum of the sending-end source, line, and receiving-end source impedances in ohms.</p> <p>Here, the instantaneous phase setting of 8,000 amps is greater than the calculated system current of 5,716 amps; therefore, it meets PRC-026-2 – Attachment B, Criterion B.</p>			
Eq. (102)	$V_S = \frac{V_{LL} \angle 120^\circ}{\sqrt{3}} \times 1.05$		
	$V_S = \frac{230,000 \angle 120^\circ V}{\sqrt{3}} \times 1.05$		
	$V_S = 139,430 \angle 120^\circ V$		
Receiving-end generator terminal voltage.			
Eq. (103)	$V_R = \frac{V_{LL} \angle 0^\circ}{\sqrt{3}} \times 1.05$		
	$V_R = \frac{230,000 \angle 0^\circ V}{\sqrt{3}} \times 1.05$		
	$V_R = 139,430 \angle 0^\circ V$		
<p>The total impedance of the system (<math>Z_{sys}</math>) equals the sum of the sending-end source impedance (<math>Z_S</math>), the impedance of the line (<math>Z_L</math>), and receiving-end impedance (<math>Z_R</math>) in ohms.</p>			
Given:	$Z_S = 3 + j26 \Omega$	$Z_L = 1.3 + j8.7 \Omega$	$Z_R = 0.3 + j7.3 \Omega$
Eq. (104)	$Z_{sys} = Z_S + Z_L + Z_R$		
	$Z_{sys} = (3 + j26) \Omega + (1.3 + j8.7) \Omega + (0.3 + j7.3) \Omega$		
	$Z_{sys} = 4.6 + j42 \Omega$		
Total system current.			
Eq. (105)	$I_{sys} = \frac{(V_S - V_R)}{Z_{sys}}$		
	$I_{sys} = \frac{(139,430 \angle 120^\circ V - 139,430 \angle 0^\circ V)}{(4.6 + j42) \Omega}$		
	$I_{sys} = 5,715.82 \angle 66.25^\circ A$		

### Application Specific to Three-Terminal Lines

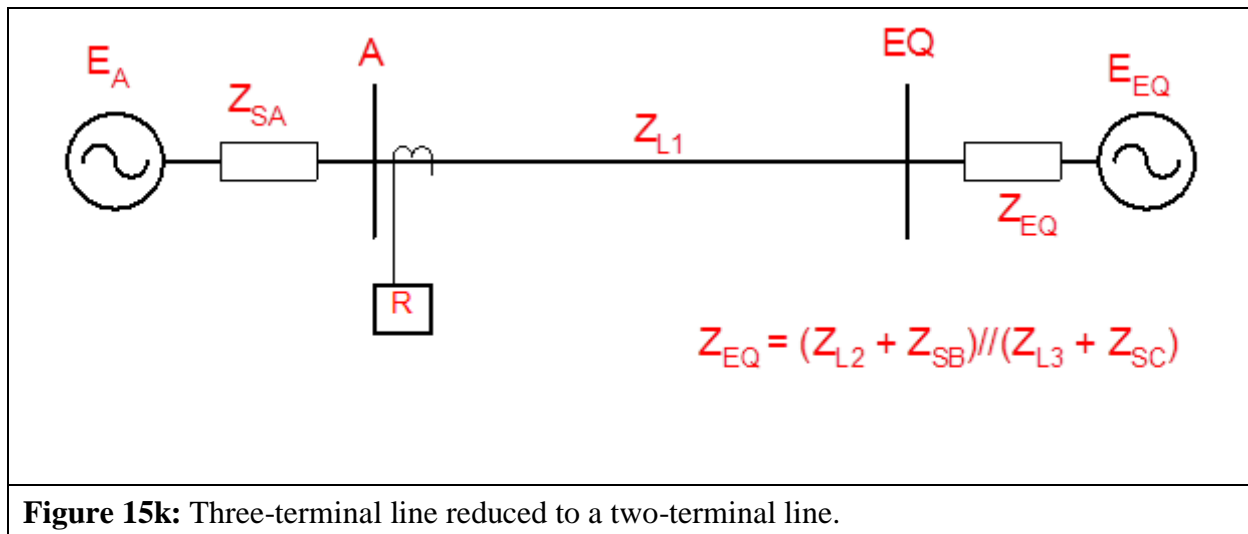
If a three-terminal line is identified as an Element that is susceptible to a power swing based on Requirement R1, the load-responsive protective relays at each end of the three-terminal line must be evaluated.

As shown in Figure 15j, the source impedances at each end of the line can be obtained from the similar short circuit calculation as for the two-terminal line (assuming the parallel transfer impedances are ignored).



**Figure 15j:** Three-terminal line. To evaluate the load-responsive protective relays on the three-terminal line at Terminal A, the circuit in Figure 15j is first reduced to the equivalent circuit shown in Figure 15k. The evaluation process for the load-responsive protective relays on the line at Terminal A will now be the same as that of the two-terminal line.





**Figure 15k:** Three-terminal line reduced to a two-terminal line.

### Application to Generation Elements

As with transmission BES Elements, the determination of the apparent impedance seen at an Element located at, or near, a generation Facility is complex for power swings due to various interdependent quantities. These variances in quantities are caused by changes in machine internal voltage, speed governor action, voltage regulator action, the reaction of other local generators, and the reaction of other interconnected transmission BES Elements as the event progresses through the time domain. Though transient stability simulations may be used to determine the apparent impedance for verifying load-responsive relay settings,<sup>18,19</sup> Requirement R2, PRC-026-2 – Attachment B, Criteria A and B provides a simplified method for evaluating the load-responsive protective relay’s susceptibility to tripping in response to a stable power swing without requiring stability simulations.

In general, the electrical center will be in the transmission system for cases where the generator is connected through a weak transmission system (high external impedance). In other cases where the generator is connected through a strong transmission system, the electrical center could be inside the unit connected zone.<sup>20</sup> In either case, load-responsive protective relays connected at the generator terminals or at the high-voltage side of the generator step-up (GSU) transformer may be challenged by power swings. Relays that may be challenged by power swings will be determined by the Planning Coordinator in Requirement R1 or by the Generator Owner after becoming aware of a generator, transformer, or transmission line BES Element that tripped<sup>21</sup> in response to a stable or unstable power swing due to the operation of its protective relay(s) in Requirement R2.

<sup>18</sup> Donald Reimert, *Protective Relaying for Power Generation Systems*, Boca Raton, FL, CRC Press, 2006.

<sup>19</sup> Prabha Kundur, *Power System Stability and Control*, EPRI, McGraw Hill, Inc., 1994.

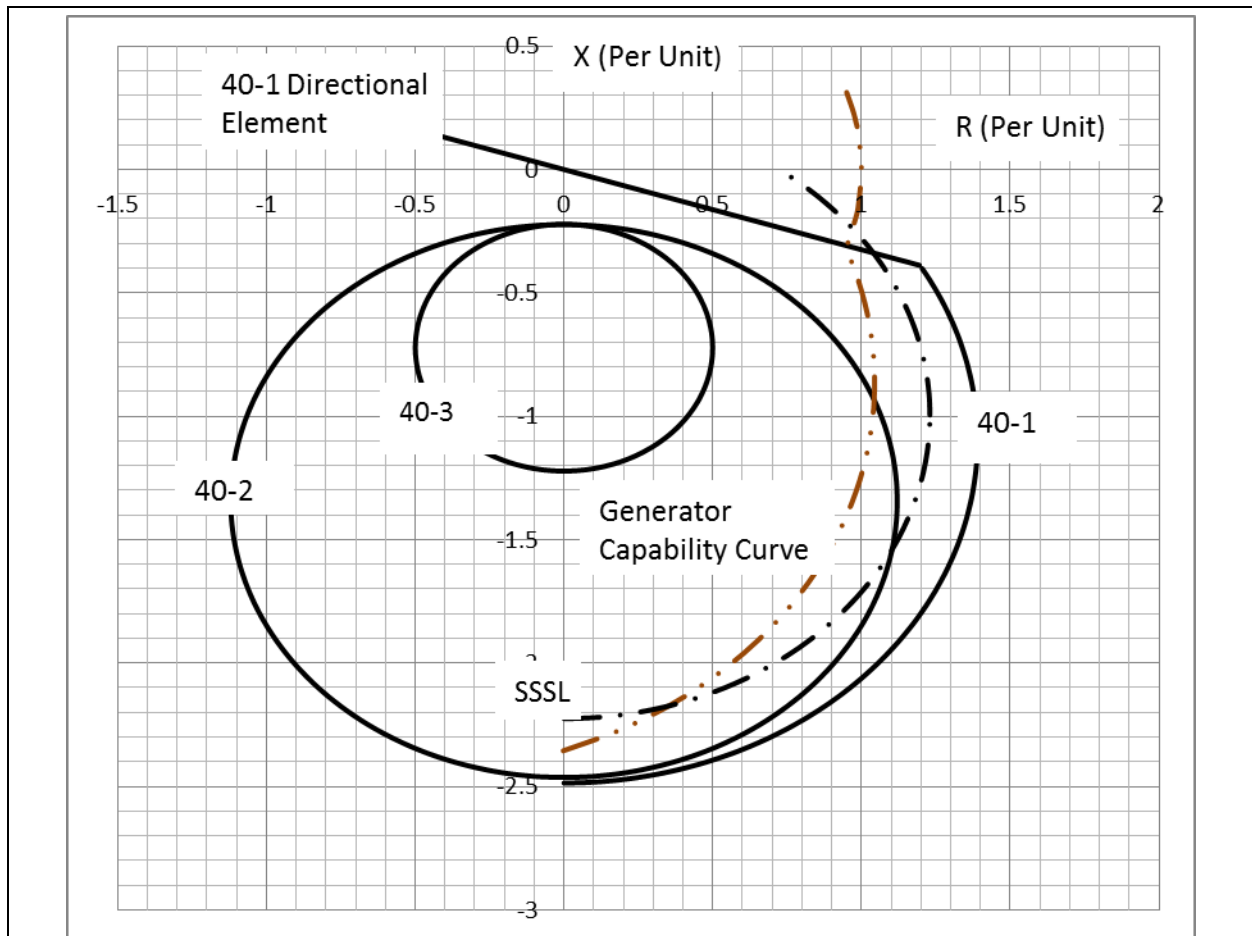
<sup>20</sup> Ibid, Kundur.

<sup>21</sup> See Guidelines and Technical Basis section, “Becoming Aware of an Element That Tripped in Response to a Power Swing,”

Voltage controlled time-overcurrent and voltage-restrained time-overcurrent relays are excluded from this standard. When these relays are set based on equipment permissible overload capability, their operating times are much greater than 15 cycles for the current levels observed during a power swing.

Instantaneous overcurrent, time-overcurrent, and definite-time overcurrent relays with a time delay of less than 15 cycles for the current levels observed during a power swing are applicable and are required to be evaluated for identified Elements.

The generator loss-of-field protective function is provided by impedance relay(s) connected at the generator terminals. The settings are applied to protect the generator from a partial or complete loss of excitation under all generator loading conditions and, at the same time, be immune to tripping on stable power swings. It is more likely that the loss-of-field relay would operate during a power swing when the automatic voltage regulator (AVR) is in manual mode rather than when in automatic mode.<sup>22</sup> Figure 16 illustrates the loss-of-field relay in the R-X plot, which typically includes up to three zones of protection.



**Figure 16:** An R-X graph of typical impedance settings for loss-of-field relays.

<sup>22</sup> John Burdy, *Loss-of-excitation Protection for Synchronous Generators GER-3183*, General Electric Company.

Loss-of-field characteristic 40-1 has a wider impedance characteristic (positive offset) than characteristic 40-2 or characteristic 40-3 and provides additional generator protection for a partial loss of field or a loss of field under low load (less than 10% of rated). The tripping logic of this protection scheme is established by a directional contact, a voltage setpoint, and a time delay. The voltage and time delay add security to the relay operation for stable power swings. Characteristic 40-3 is less sensitive to power swings than characteristic 40-2 and is set outside the generator capability curve in the leading direction. Regardless of the relay impedance setting, PRC-019<sup>23</sup> requires that the “in-service limiters operate before Protection Systems to avoid unnecessary trip” and “in-service Protection System devices are set to isolate or de-energize equipment in order to limit the extent of damage when operating conditions exceed equipment capabilities or stability limits.” Time delays for tripping associated with loss-of-field relays<sup>24,25</sup> have a range from 15 cycles for characteristic 40-2 to 60 cycles for characteristic 40-1 to minimize tripping during stable power swings. In PRC-026-2, 15 cycles establishes a threshold for applicability; however, it is the responsibility of the Generator Owner to establish settings that provide security against stable power swings and, at the same time, dependable protection for the generator.

The simple two-machine system circuit (method also used in the Application to Transmission Elements section) is used to analyze the effect of a power swing at a generator facility for load-responsive relays. In this section, the calculation method is used for calculating the impedance seen by the relay connected at a point in the circuit.<sup>26</sup> The electrical quantities used to determine the apparent impedance plot using this method are generator saturated transient reactance ( $X'_d$ ), GSU transformer impedance ( $X_{GSU}$ ), transmission line impedance ( $Z_L$ ), and the system equivalent ( $Z_e$ ) at the point of interconnection. All impedance values are known to the Generator Owner except for the system equivalent. The system equivalent is obtainable from the Transmission Owner. The sending-end and receiving-end source voltages are varied from 0.0 to 1.0 per unit to form the lens shape portion of the unstable power swing region. The voltage range of 0.7 to 1.0 results in a ratio range from 0.7 to 1.43. This ratio range is used to form the lower and upper loss-of-synchronism circle shapes of the unstable power swing region. A system separation angle of 120 degrees is used in accordance with PRC-026-2 – Attachment B criteria for each load-responsive protective relay evaluation.

Table 15 below is an example calculation of the apparent impedance locus method based on Figures 17 and 18.<sup>27</sup> In this example, the generator is connected to the 345 kV transmission system through the GSU transformer and has the listed ratings. Note that the load-responsive protective relays in this example may have ownership with the Generator Owner or the Transmission Owner.

---

<sup>23</sup> Coordination of Generating Unit or Plant Capabilities, Voltage Regulating Controls, and Protection

<sup>24</sup> Ibid, Burdy.

<sup>25</sup> *Applied Protective Relaying*, Westinghouse Electric Corporation, 1979.

<sup>26</sup> Edward Wilson Kimbark, *Power System Stability, Volume II: Power Circuit Breakers and Protective Relays*, Published by John Wiley and Sons, 1950.

<sup>27</sup> Ibid, Kimbark.

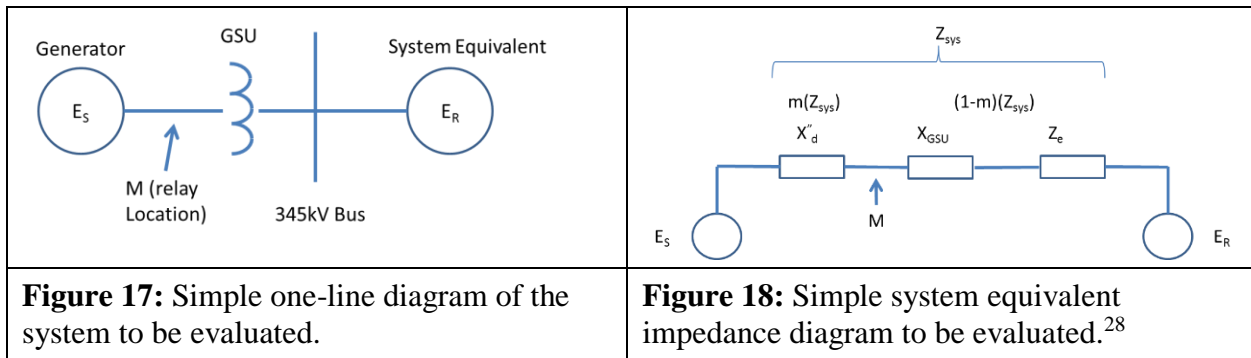


Table15: Example Data (Generator)	
Input Descriptions	Input Values
Synchronous Generator nameplate (MVA)	940 MVA
Saturated transient reactance (940 MVA base)	$X'_d = 0.3845$ per unit
Generator rated voltage (Line-to-Line)	20 kV
Generator step-up (GSU) transformer rating	880 MVA
GSU transformer reactance (880 MVA base)	$X_{GSU} = 16.05\%$
System Equivalent (100 MVA base)	$Z_e = 0.00723 \angle 90^\circ$ per unit
Generator Owner Load-Responsive Protective Relays	
40-1	Positive Offset Impedance
	Offset = 0.294 per unit
	Diameter = 0.294 per unit
40-2	Negative Offset Impedance
	Offset = 0.22 per unit
	Diameter = 2.24 per unit
40-3	Negative Offset Impedance
	Offset = 0.22 per unit
	Diameter = 1.00 per unit
21-1	Diameter = 0.643 per unit
	MTA = 85°

<sup>28</sup> Ibid, Kimbark.

Table15: Example Data (Generator)	
50	I (pickup) = 5.0 per unit
Transmission Owned Load-Responsive Protective Relays	
21-2	Diameter = 0.55 per unit
	MTA = 85°

Calculations shown for a 120 degree angle and  $E_S/E_R = 1$ . The equation for calculating  $Z_R$  is:<sup>29</sup>

$$\text{Eq. (106)} \quad Z_R = \left( \frac{(1 - m)(E_S \angle \delta) + (m)(E_R)}{E_S \angle \delta - E_R} \right) \times Z_{sys}$$

Where m is the relay location as a function of the total impedance (real number less than 1)

$E_S$  and  $E_R$  is the sending-end and receiving-end voltages

$Z_{sys}$  is the total system impedance

$Z_R$  is the complex impedance at the relay location and plotted on an R-X diagram

All of the above are constants (940 MVA base) while the angle  $\delta$  is varied. Table 16 below contains calculations for a generator using the data listed in Table 15.

Table16: Example Calculations (Generator)			
The following calculations are on a 940 MVA base.			
Given:	$X'_d = j0.3845 pu$	$X_{GSU} = j0.17144 pu$	$Z_e = j0.06796 pu$
Eq. (107)	$Z_{sys} = X'_d + X_{GSU} + Z_e$		
	$Z_{sys} = j0.3845 pu + j0.17144 pu + j0.06796 pu$		
	$Z_{sys} = 0.6239 \angle 90^\circ pu$		
Eq. (108)	$m = \frac{X'_d}{Z_{sys}} = \frac{0.3845}{0.6239} = 0.6163$		
Eq. (109)	$Z_R = \left( \frac{(1 - m)(E_S \angle \delta) + (m)(E_R)}{E_S \angle \delta - E_R} \right) \times Z_{sys}$		
	$Z_R = \left( \frac{(1 - 0.6163) \times (1 \angle 120^\circ) + (0.6163)(1 \angle 0^\circ)}{1 \angle 120^\circ - 1 \angle 0^\circ} \right) \times (0.6239 \angle 90^\circ) pu$		

<sup>29</sup> Ibid, Kimbark.

Table16: Example Calculations (Generator)	
	$Z_R = \left( \frac{0.4244 + j0.3323}{-1.5 + j 0.866} \right) \times (0.6239 \angle 90^\circ) pu$
	$Z_R = (0.3116 \angle - 111.95^\circ) \times (0.6239 \angle 90^\circ) pu$
	$Z_R = 0.194 \angle - 21.95^\circ pu$
	$Z_R = -0.18 - j0.073 pu$

Table 17 lists the swing impedance values at other angles and at  $E_S/E_R = 1, 1.43,$  and  $0.7$ . The impedance values are plotted on an R-X graph with the center being at the generator terminals for use in evaluating impedance relay settings.

Table 17: Sample Calculations for a Swing Impedance Chart for Varying Voltages at the Sending-End and Receiving-End.						
Angle ( $\delta$ ) (Degrees)	$E_S/E_R=1$		$E_S/E_R=1.43$		$E_S/E_R=0.7$	
	$Z_R$		$Z_R$		$Z_R$	
	Magnitude (pu)	Angle (Degrees)	Magnitude (pu)	Angle (Degrees)	Magnitude (pu)	Angle (Degrees)
90	0.320	-13.1	0.296	6.3	0.344	-31.5
120	0.194	-21.9	0.173	-0.4	0.227	-40.1
150	0.111	-41.0	0.082	-10.3	0.154	-58.4
210	0.111	-25.9	0.082	190.3	0.154	238.4
240	0.194	201.9	0.173	180.4	0.225	220.1
270	0.320	193.1	0.296	173.7	0.344	211.5

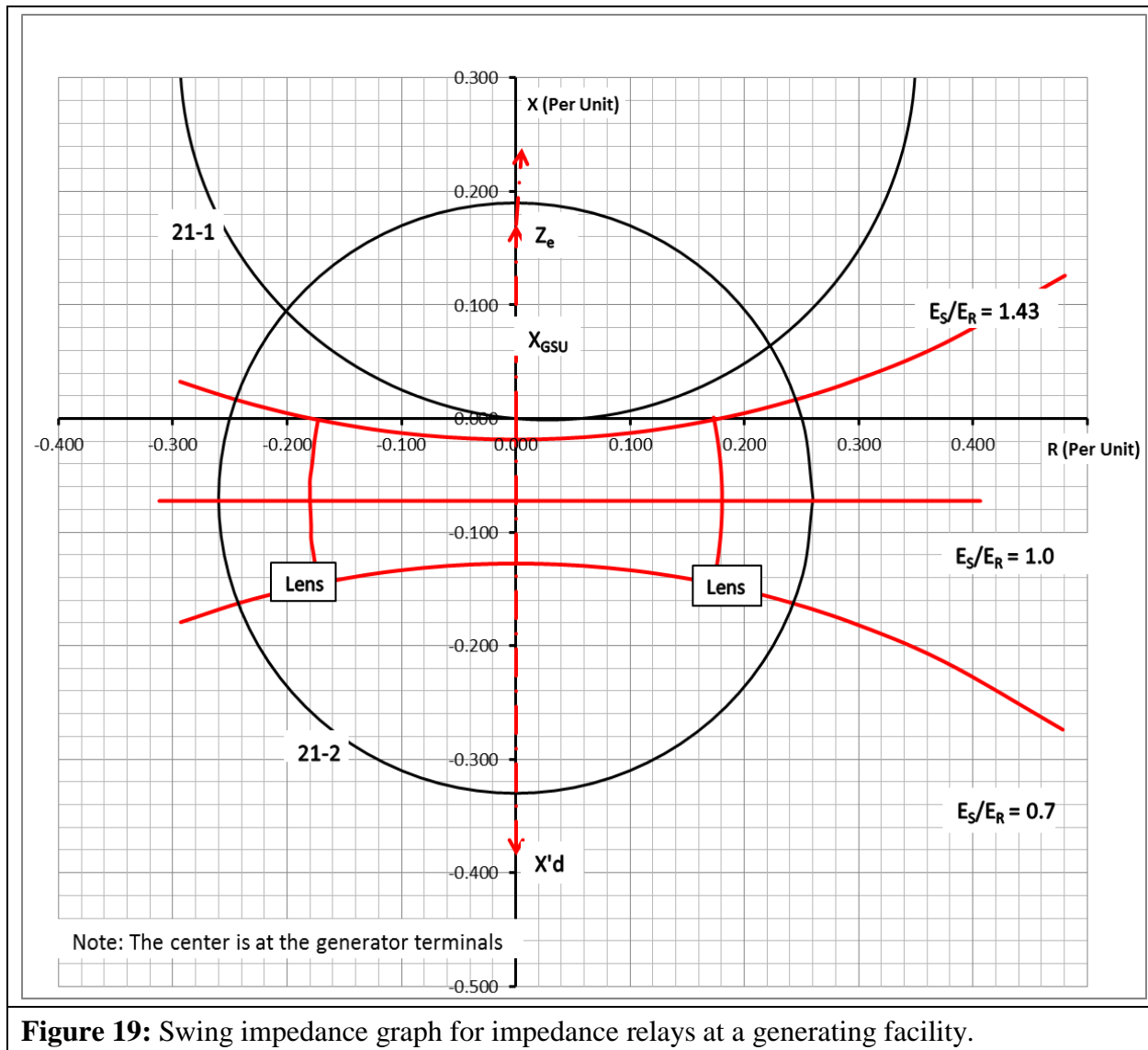
## Requirement R2 Generator Examples

### ***Distance Relay Application***

Based on PRC-026-2– Attachment B, Criterion A, the distance relay (21-1) (i.e., owned by the Generation Owner) characteristic is in the region where a stable power swing would not occur as shown in Figure 19. There is no further obligation to the owner in this standard for this load-responsive protective relay.

The distance relay (21-2) (i.e., owned by the Transmission Owner) is connected at the high-voltage side of the GSU transformer and its impedance characteristic is in the region where a stable power swing could occur causing the relay to operate. In this example, if the intentional time delay of this relay is less than 15 cycles, the PRC-026 – Attachment B, Criterion A cannot be met, thus the Transmission Owner is required to create a CAP (Requirement R3). Some of the options include,

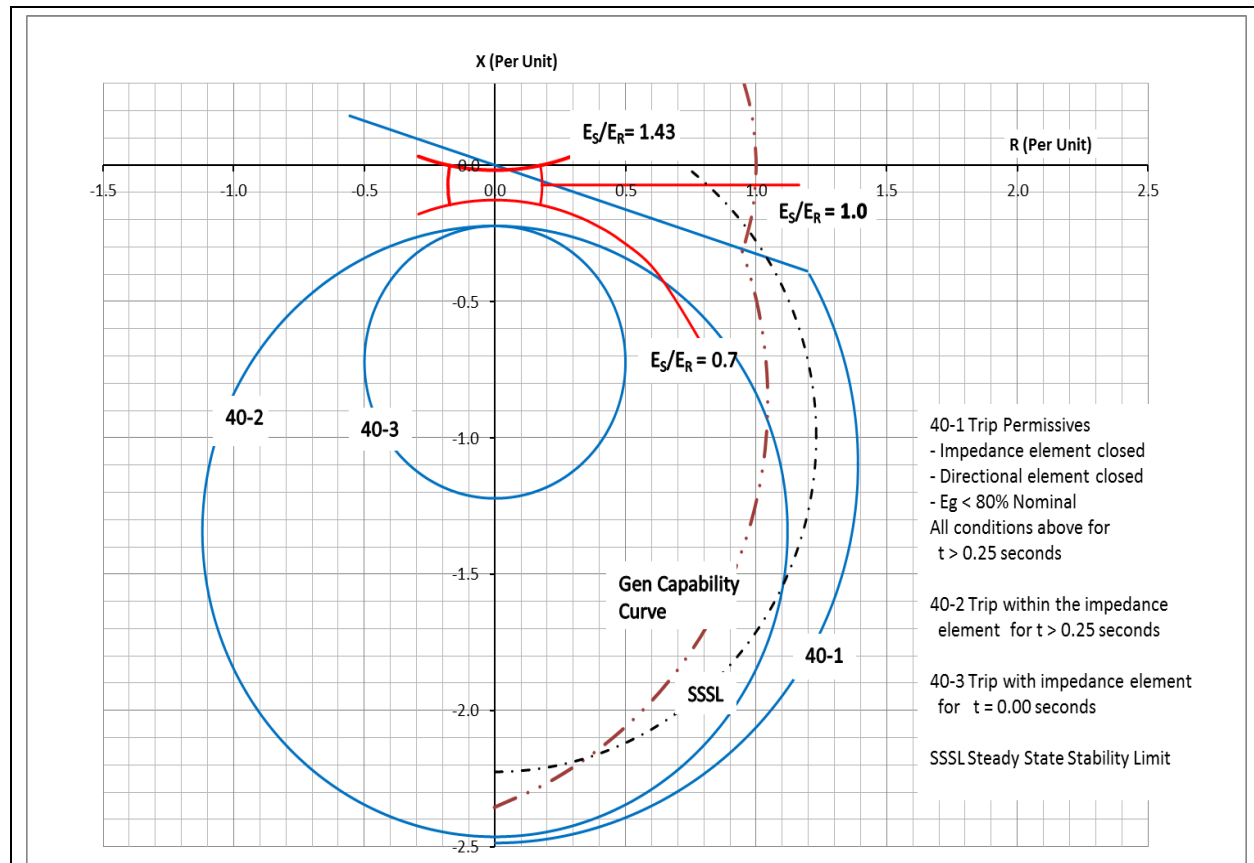
but are not limited to, changing the relay setting (i.e., impedance reach, angle, time delay), modify the scheme (i.e., add PSB), or replace the Protection System. Note that the relay may be excluded from this standard if it has an intentional time delay equal to or greater than 15 cycles.



### Loss-of-Field Relay Application

In Figure 20, the R-X diagram shows the loss-of-field relay (40-1 and 40-2) characteristics are in the region where a stable power swing can cause a relay operation. Protective relay 40-1 would be excluded if it has an intentional time delay equal to or greater than 15 cycles. Similarly, 40-2 would be excluded if its intentional time delay is equal to or greater than 15 cycles. For example, if 40-1 has a time delay of 1 second and 40-2 has a time delay of 0.25 seconds, they are excluded and there is no further obligation on the Generator Owner in this standard for these relays. The

loss-of-field relay characteristic 40-3 is entirely inside the unstable power swing region. In this case, the owner may select high speed tripping on operation of the 40-3 impedance element.



**Figure 20:** Typical R-X graph for loss-of-field relays with a portion of the unstable power swing region defined by PRC-026-2 – Attachment B, Criterion A.

### Instantaneous Overcurrent Relay

In similar fashion to the transmission line overcurrent example calculation in Table 14, the instantaneous overcurrent relay minimum setting is established by PRC-026-2 – Attachment B, Criterion B. The solution is found by:

$$\text{Eq. (110)} \quad I_{sys} = \frac{E_S - E_R}{Z_{sys}}$$

As stated in the relay settings in Table 15, the relay is installed on the high-voltage side of the GSU transformer with a pickup of 5.0 per unit. The maximum allowable current is calculated below.

$$I_{sys} = \frac{(1.05 \angle 120^\circ - 1.05 \angle 0^\circ)}{0.6239 \angle 90^\circ} pu$$



$$I_{sys} = \frac{1.819 \angle 150^\circ}{0.6239 \angle 90^\circ} pu$$

$$I_{sys} = 2.91 \angle 60^\circ pu$$

The instantaneous phase setting of 5.0 per unit is greater than the calculated system current of 2.91 per unit; therefore, it meets the PRC-026-2 – Attachment B, Criterion B.

### ***Out-of-Step Tripping for Generation Facilities***

Out-of-step protection for the generator generally falls into three different schemes. The first scheme is a distance relay connected at the high-voltage side of the GSU transformer with the directional element looking toward the generator. Because this relay setting may be the same setting used for generator backup protection (see Requirement R2 Generator Examples, Distance Relay Application), it is susceptible to tripping in response to stable power swings and would require modification. Because this scheme is susceptible to tripping in response to stable power swings and any modification to the mho circle will jeopardize the overall protection of the out-of-step protection of the generator, available technical literature does not recommend using this scheme specifically for generator out-of-step protection. The second and third out-of-step Protection System schemes are commonly referred to as single and double blinder schemes. These schemes are installed or enabled for out-of-step protection using a combination of blinders, a mho element, and timers. The combination of these protective relay functions provides out-of-step protection and discrimination logic for stable and unstable power swings. Single blinder schemes use logic that discriminate between stable and unstable power swings by issuing a trip command after the first slip cycle. Double blinder schemes are more complex than the single blinder scheme and, depending on the settings of the inner blinder, a trip for a stable power swing may occur. While the logic discriminates between stable and unstable power swings in either scheme, it is important that the trip initiating blinders be set at an angle greater than the stability limit of 120 degrees to remove the possibility of a trip for a stable power swing. Below is a discussion of the double blinder scheme.

### ***Double Blinder Scheme***

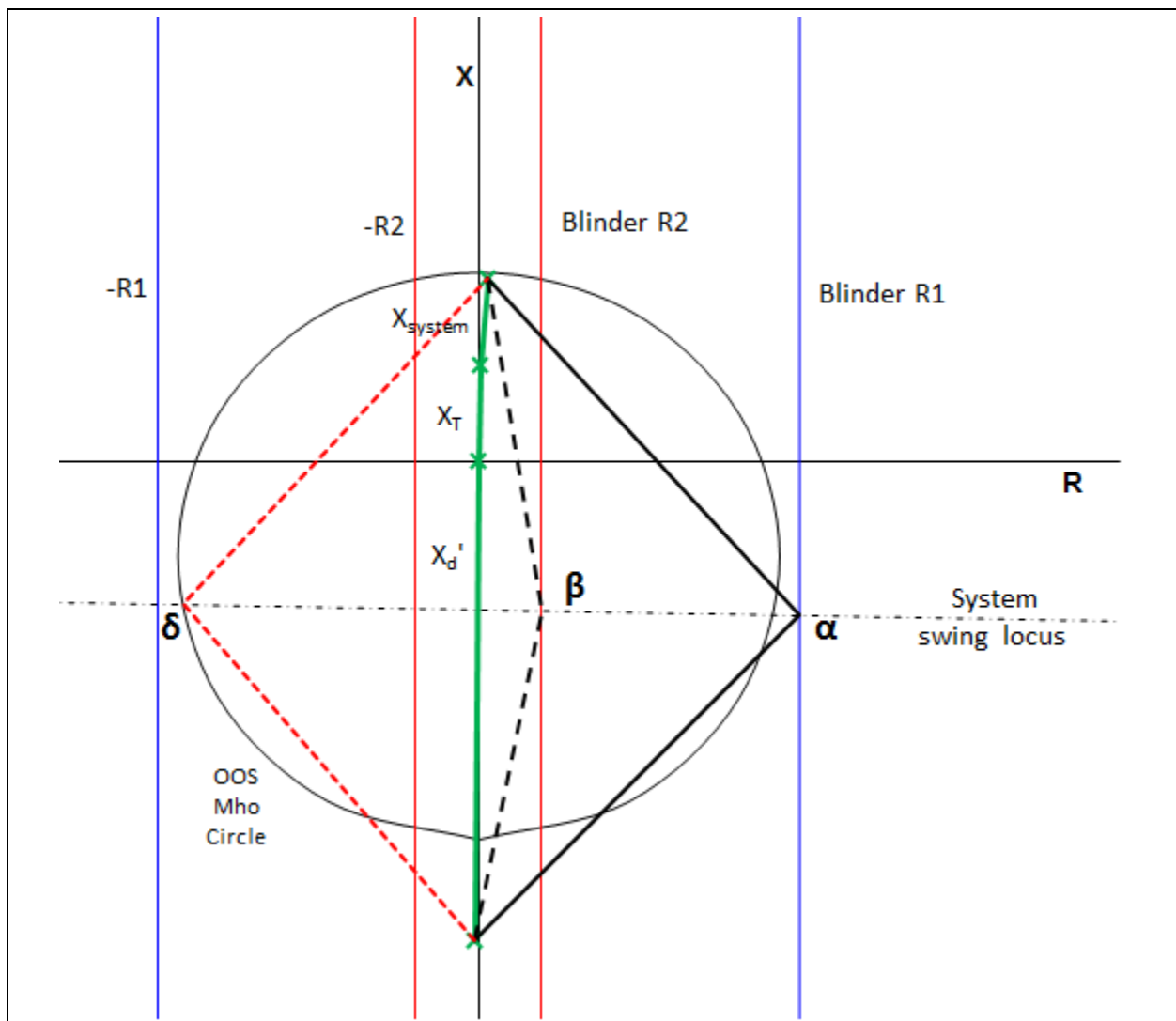
The double blinder scheme is a method for measuring the rate of change of positive sequence impedance for out-of-step swing detection. The scheme compares a timer setting to the actual elapsed time required by the impedance locus to pass between two impedance characteristics. In this case, the two impedance characteristics are simple blinders, each set to a specific resistive reach on the R-X plane. Typically, the two blinders on the left half plane are the mirror images of those on the right half plane. The scheme typically includes a mho characteristic which acts as a starting element, but is not a tripping element.

The scheme detects the blinder crossings and time delays as represented on the R-X plane as shown in Figure 21. The system impedance is composed of the generator transient ( $X_d'$ ), GSU transformer ( $X_T$ ), and transmission system ( $X_{system}$ ), impedances.

The scheme logic is initiated when the swing locus crosses the outer Blinder R1 (Figure 21), on the right at separation angle  $\alpha$ . The scheme only commits to take action when a swing crosses the

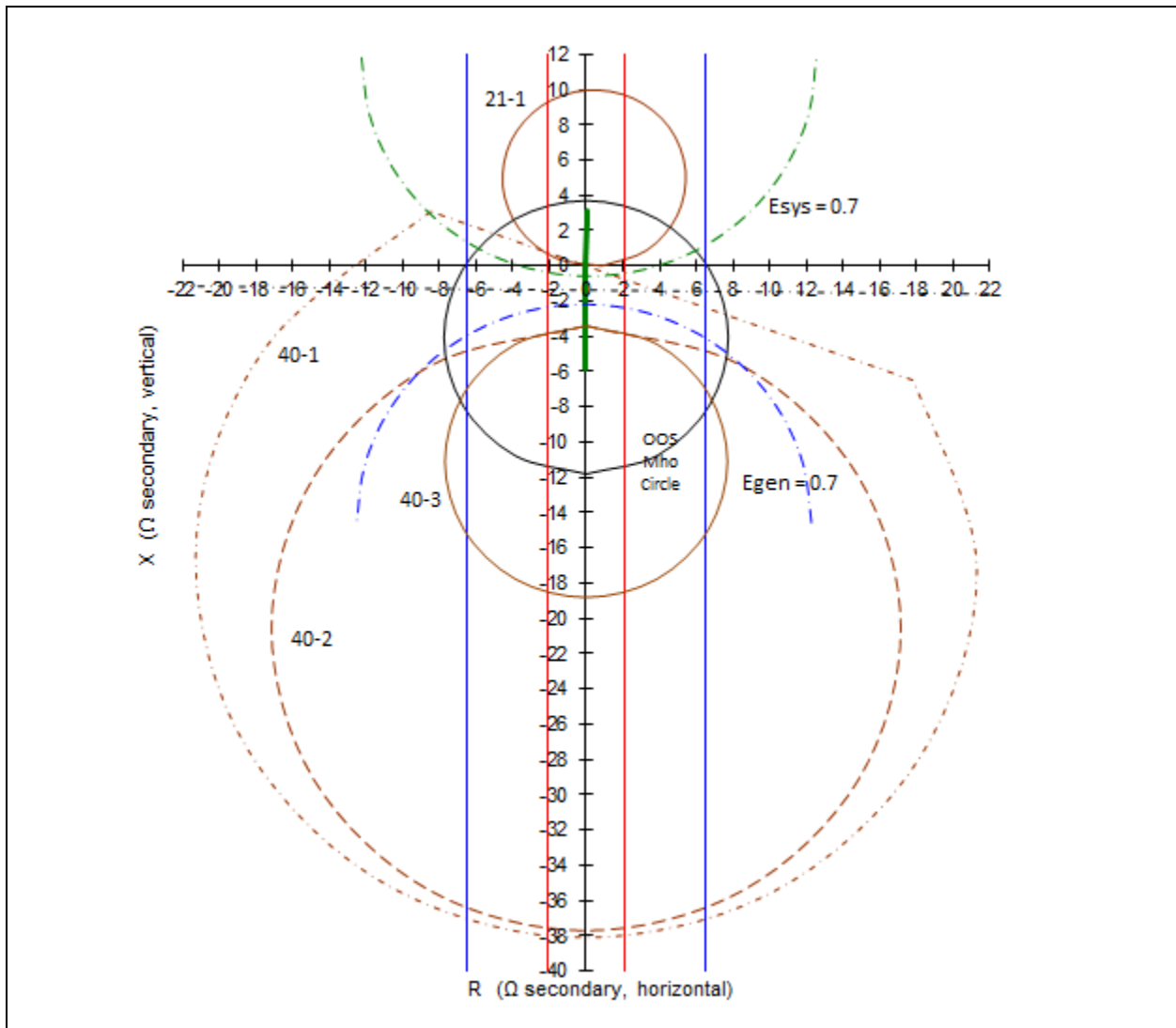
inner blinder. At this point the scheme logic seals in the out-of-step trip logic at separation angle  $\beta$ . Tripping actually asserts as the impedance locus leaves the scheme characteristic at separation angle  $\delta$ .

The power swing may leave both inner and outer blinders in either direction, and tripping will assert. Therefore, the inner blinder must be set such that the separation angle  $\beta$  is large enough that the system cannot recover. This angle should be set at 120 degrees or more. Setting the angle greater than 120 degrees satisfies the PRC-026-2 – Attachment B, Criterion A (No. 1, 1<sup>st</sup> bullet) since the tripping function is asserted by the blinder element. Transient stability studies may indicate that a smaller stability limit angle is acceptable under PRC-026-2 – Attachment B, Criterion A (No. 1, 2<sup>nd</sup> bullet). In this respect, the double blinder scheme is similar to the double lens and triple lens schemes and many transmission application out-of-step schemes.



**Figure 21:** Double Blinder Scheme generic out of step characteristics.

Figure 22 illustrates a sample setting of the double blinder scheme for the example 940 MVA generator. The only setting requirement for this relay scheme is the right inner blinder, which must be set greater than the separation angle of 120 degrees (or a lesser angle based on a transient stability study) to ensure that the out-of-step protective function is expected to not trip in response to a stable power swing during non-Fault conditions. Other settings such as the mho characteristic, outer blinders, and timers are set according to transient stability studies and are not a part of this standard.



**Figure 22:** Double Blinder Out-of-Step Scheme with unit impedance data and load-responsive protective relay impedance characteristics for the example 940 MVA generator, scaled in relay secondary ohms.

### Requirement R3

To achieve the stated purpose of this standard, which is to ensure that relays are expected to not trip in response to stable power swings during non-Fault conditions, this Requirement ensures that the applicable entity develops a Corrective Action Plan (CAP) that reduces the risk of relays tripping in response to a stable power swing during non-Fault conditions that may occur on any applicable BES Element.

### Requirement R4

To achieve the stated purpose of this standard, which is to ensure that load-responsive protective relays are expected to not trip in response to stable power swings during non-Fault conditions, the applicable entity is required to implement any CAP developed pursuant to Requirement R3 such that the Protection System will meet PRC-026-2 – Attachment B criteria or can be excluded under the PRC-026-2 – Attachment A criteria (e.g., modifying the Protection System so that relay functions are supervised by power swing blocking or using relay systems that are immune to power swings), while maintaining dependable fault detection and dependable out-of-step tripping (if out-of-step tripping is applied at the terminal of the BES Element). Protection System owners are required in the implementation of a CAP to update it when actions or timetable change, until all actions are complete. Accomplishing this objective is intended to reduce the occurrence of Protection System tripping during a stable power swing, thereby improving reliability and minimizing risk to the BES.

The following are examples of actions taken to complete CAPs for a relay that did not meet PRC-026-2 – Attachment B and could be at-risk of tripping in response to a stable power swing during non-Fault conditions. A Protection System change was determined to be acceptable (without diminishing the ability of the relay to protect for faults within its zone of protection).

**Example R4a:** Actions: Settings were issued on 6/02/2015 to reduce the Zone 2 reach of the impedance relay used in the directional comparison unblocking (DCUB) scheme from 30 ohms to 25 ohms so that the relay characteristic is completely contained within the lens characteristic identified by the criterion. The settings were applied to the relay on 6/25/2015. CAP was completed on 06/25/2015.

**Example R4b:** Actions: Settings were issued on 6/02/2015 to enable out-of-step blocking on the existing microprocessor-based relay to prevent tripping in response to stable power swings. The setting changes were applied to the relay on 6/25/2015. CAP was completed on 06/25/2015.

The following is an example of actions taken to complete a CAP for a relay responding to a stable power swing that required the addition of an electromechanical power swing blocking relay.

**Example R4c:** Actions: A project for the addition of an electromechanical power swing blocking relay to supervise the Zone 2 impedance relay was initiated on 6/5/2015 to prevent tripping in response to stable power swings. The relay installation was completed on 9/25/2015. CAP was completed on 9/25/2015.

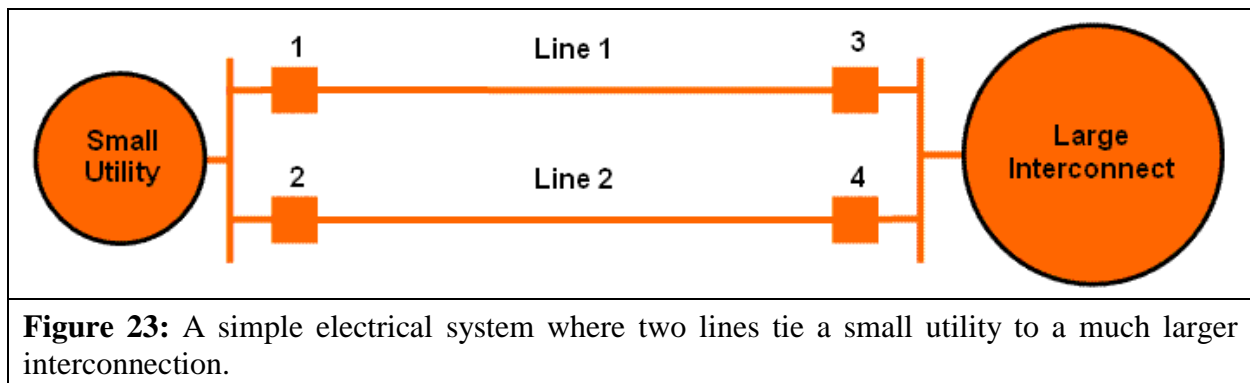
The following is an example of actions taken to complete a CAP with a timetable that required updating for the replacement of the relay.

**Example R4d:** Actions: A project for the replacement of the impedance relays at both terminals of line X with line current differential relays was initiated on 6/5/2015 to prevent tripping in response to stable power swings. The completion of the project was postponed due to line outage rescheduling from 11/15/2015 to 3/15/2016. Following the timetable change, the impedance relay replacement was completed on 3/18/2016. CAP was completed on 3/18/2016.

The CAP is complete when all the documented actions to remedy the specific problem (i.e., unnecessary tripping during stable power swings) are completed.

### Justification for Including Unstable Power Swings in the Requirements

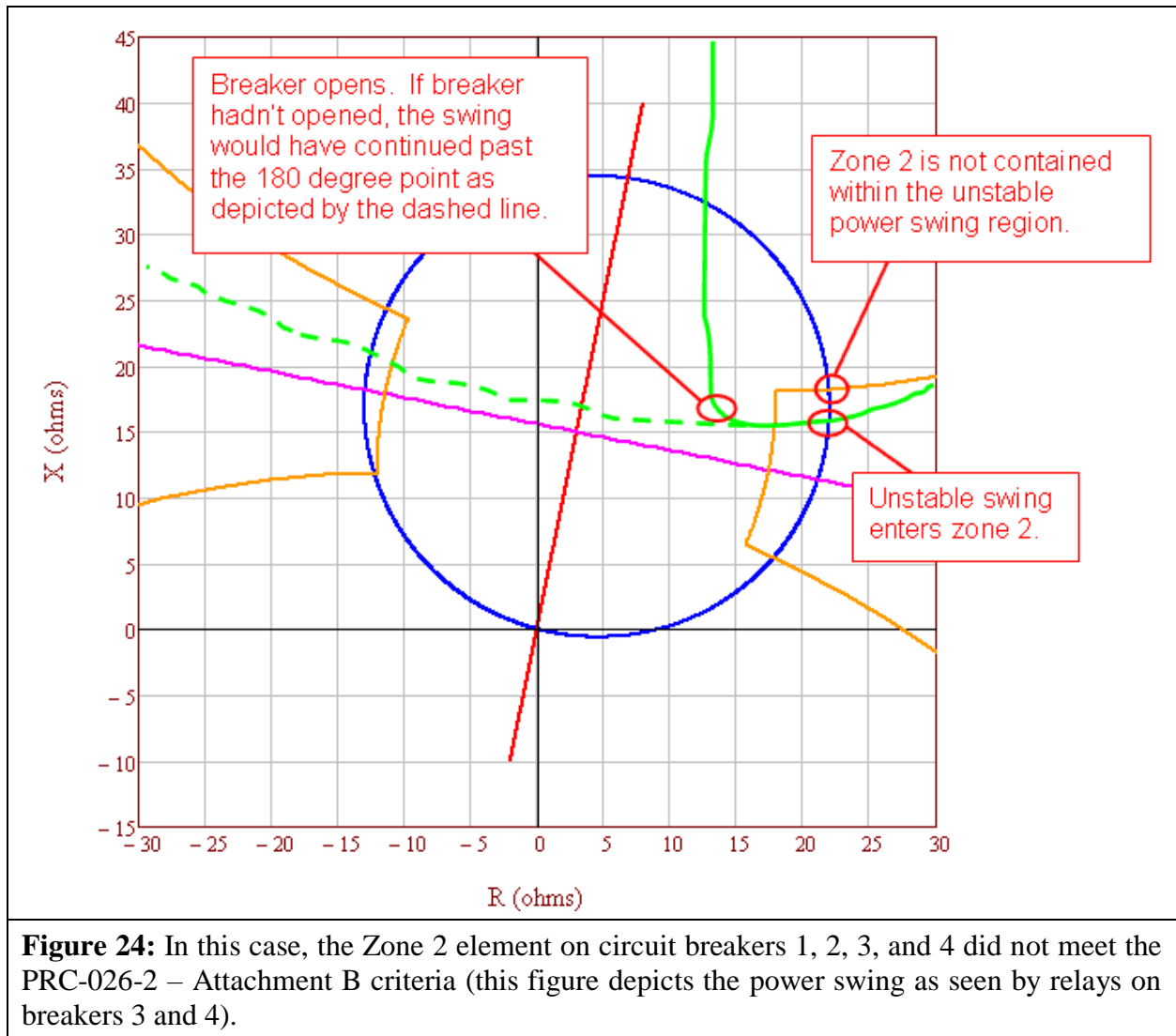
Protection Systems that are applicable to the Standard and must be secure for a stable power swing condition (i.e., meets PRC-026-2 – Attachment B criteria) are identified based on Elements that are susceptible to both stable and unstable power swings. This section provides an example of why Elements that trip in response to unstable power swings (in addition to stable power swings) are identified and that their load-responsive protective relays need to be evaluated under PRC-026-2 – Attachment B criteria.



**Figure 23:** A simple electrical system where two lines tie a small utility to a much larger interconnection.

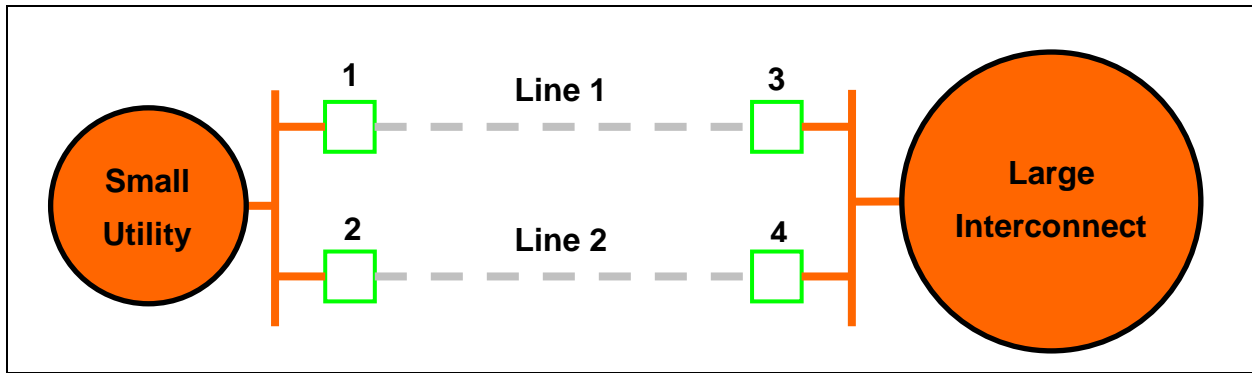
In Figure 23 the relays at circuit breakers 1, 2, 3, and 4 are equipped with a typical overreaching Zone 2 pilot system, using a Directional Comparison Blocking (DCB) scheme. Internal faults (or power swings) will result in instantaneous tripping of the Zone 2 relays if the measured fault or power swing impedance falls within the zone 2 operating characteristic. These lines will trip on

pilot Zone 2 for out-of-step conditions if the power swing impedance characteristic enters into Zone 2. All breakers are rated for out-of-phase switching.



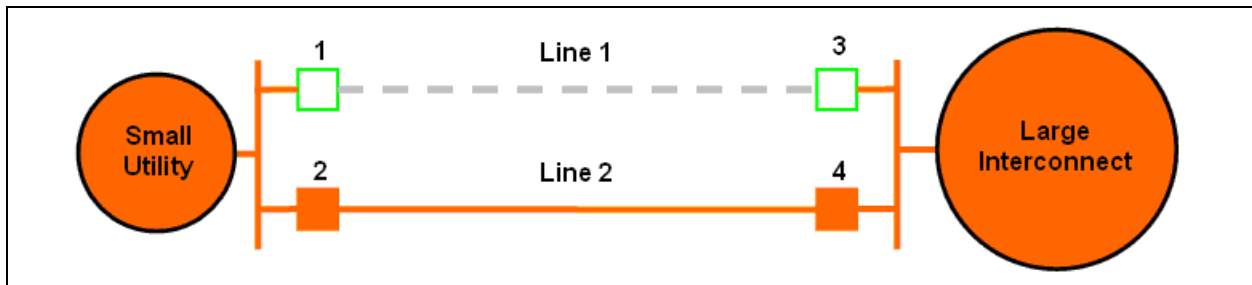
**Figure 24:** In this case, the Zone 2 element on circuit breakers 1, 2, 3, and 4 did not meet the PRC-026-2 – Attachment B criteria (this figure depicts the power swing as seen by relays on breakers 3 and 4).

In Figure 24, a large disturbance occurs within the small utility and its system goes out-of-step with the large interconnect. The small utility is importing power at the time of the disturbance. The actual power swing, as shown by the solid green line, enters the Zone 2 relay characteristic on the terminals of Lines 1, 2, 3, and 4 causing both lines to trip as shown in Figure 25.



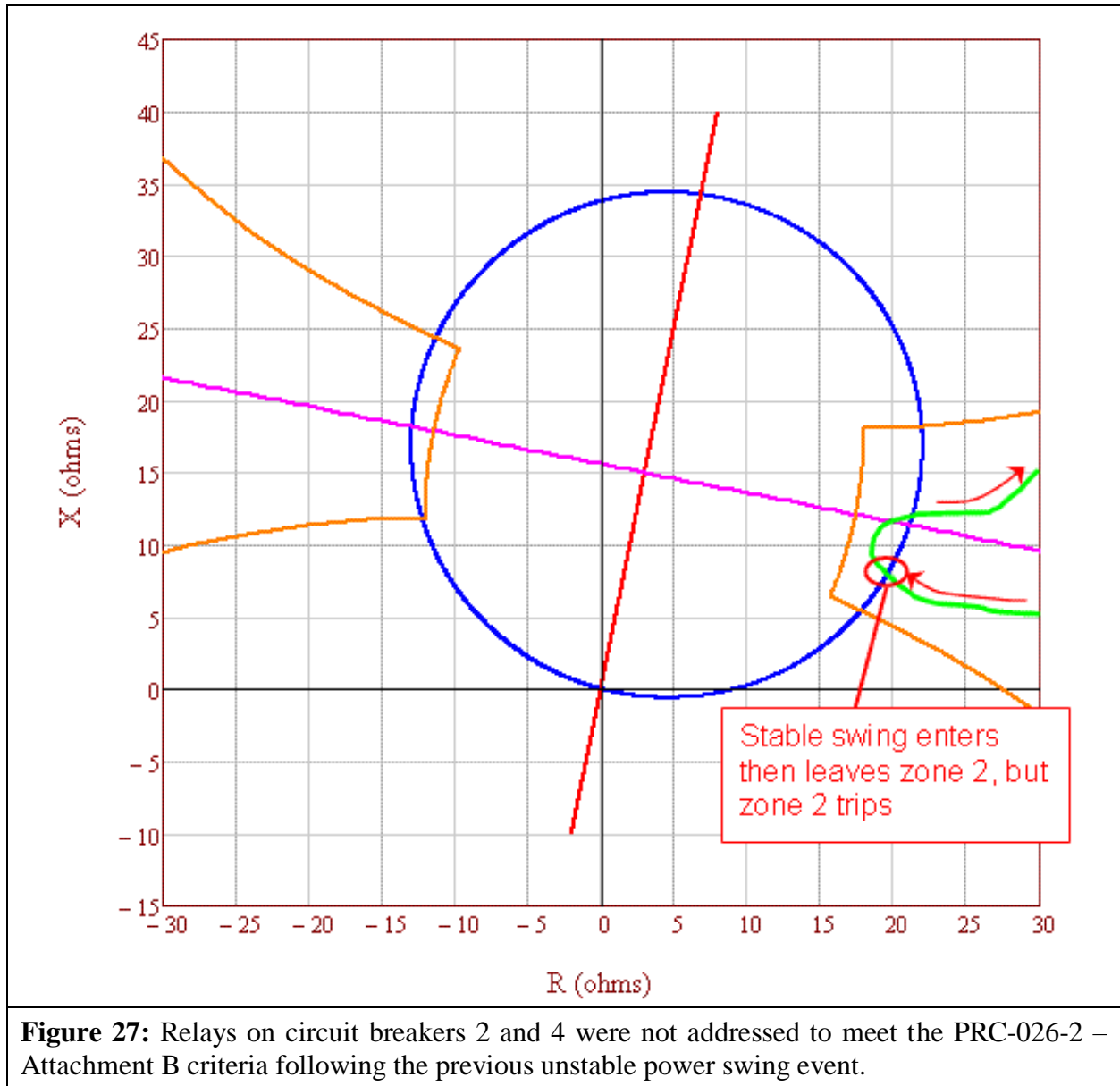
**Figure 25:** Islanding of the small utility due to Lines 1 and 2 tripping in response to an unstable power swing.

In Figure 25, the relays at circuit breakers 1, 2, 3, and 4 have correctly tripped due to the unstable power swing (shown by the dashed green line in Figure 24), de-energizing Lines 1 and 2, and creating an island between the small utility and the big interconnect. The small utility shed 500 MW of load on underfrequency and maintained a load to generation balance.



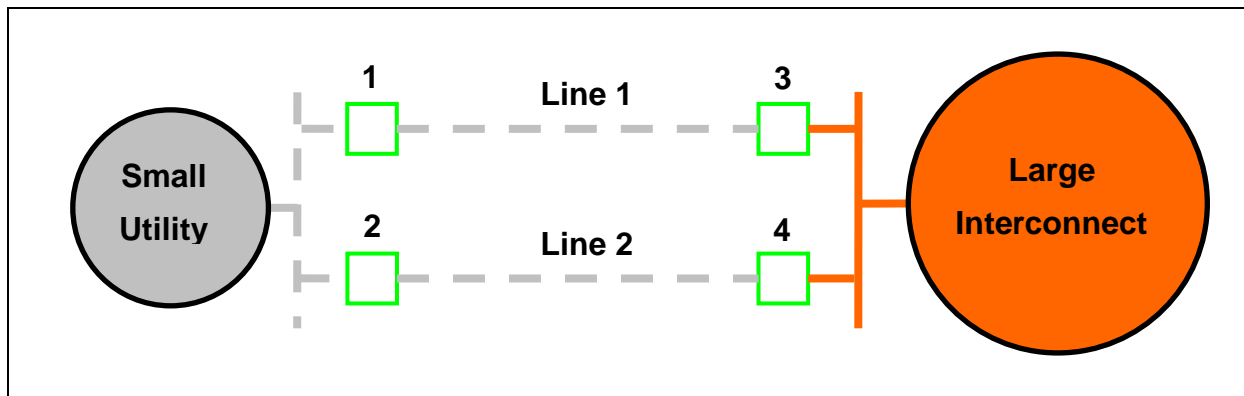
**Figure 26:** Line 1 is out-of-service for maintenance, Line 2 is loaded beyond its normal rating (but within its emergency rating).

Subsequent to the correct tripping of Lines 1 and 2 for the unstable power swing in Figure 25, another system disturbance occurs while the system is operating with Line 1 out-of-service for maintenance. The disturbance causes a stable power swing on Line 2, which challenges the relays at circuit breakers 2 and 4 as shown in Figure 27.



If the relays on circuit breakers 2 and 4 were not addressed under the Requirements for the previous unstable power swing condition, the relays would trip in response to the stable power swing, which would result in unnecessary system separation, load shedding, and possibly cascading or blackout.





**Figure 28:** Possible blackout of the small utility.

If the relays that tripped in response to the previous unstable power swing condition in Figure 24 were addressed under the Requirements to meet PRC-026-2 - Attachment B criteria, the unnecessary tripping of the relays for the stable power swing shown in Figure 28 would have been averted, and the possible blackout of the small utility would have been avoided.

### Rationale

During development of this standard, text boxes were embedded within the standard to explain the rationale for various parts of the standard. Upon BOT approval, the text from the rationale text boxes was moved to this section.

#### Rationale for R1

The Planning Coordinator has a wide-area view and is in the position to identify generator, transformer, and transmission line BES Elements which meet the criteria, if any. The criteria-based approach is consistent with the NERC System Protection and Control Subcommittee (SPCS) technical document *Protection System Response to Power Swings*, August 2013 (“PSRPS Report”),<sup>30</sup> which recommends a focused approach to determine an at-risk BES Element. See the Guidelines and Technical Basis for a detailed discussion of the criteria.

#### Rationale for R2

The Generator Owner and Transmission Owner are in a position to determine whether their load-responsive protective relays meet the PRC-026-2 – Attachment B criteria. Generator, transformer, and transmission line BES Elements are identified by the Planning Coordinator in Requirement R1 and by the Generator Owner and Transmission Owner following an actual event where the Generator Owner and Transmission Owner became aware (i.e., through an event analysis or Protection System review) tripping was due to a stable or unstable power swing. A period of 12 calendar months allows sufficient time for the entity to conduct the evaluation.

<sup>30</sup> NERC System Protection and Control Subcommittee, *Protection System Response to Power Swings*, August 2013:  
[http://www.nerc.com/comm/PC/System%20Protection%20and%20Control%20Subcommittee%20SPCS%2020/SPCS%20Power%20Swing%20Report\\_Final\\_20131015.pdf](http://www.nerc.com/comm/PC/System%20Protection%20and%20Control%20Subcommittee%20SPCS%2020/SPCS%20Power%20Swing%20Report_Final_20131015.pdf)

### **Rationale for R3**

To meet the reliability purpose of the standard, a CAP is necessary to ensure the entity's Protection System meets the PRC-026-2 – Attachment B criteria (1<sup>st</sup> bullet) so that protective relays are expected to not trip in response to stable power swings. A CAP may also be developed to modify the Protection System for exclusion under PRC-026-2 – Attachment A (2<sup>nd</sup> bullet). Such an exclusion will allow the Protection System to be exempt from the Requirement for future events. The phrase, "...while maintaining dependable fault detection and dependable out-of-step tripping..." in Requirement R3 describes that the entity is to comply with this standard, while achieving their desired protection goals. Refer to the Guidelines and Technical Basis, Introduction, for more information.

### **Rationale for R4**

Implementation of the CAP must accomplish all identified actions to be complete to achieve the desired reliability goal. During the course of implementing a CAP, updates may be necessary for a variety of reasons such as new information, scheduling conflicts, or resource issues. Documenting CAP changes and completion of activities provides measurable progress and confirmation of completion.

### **Rationale for Attachment B (Criterion A)**

The PRC-026-2 – Attachment B, Criterion A provides a basis for determining if the relays are expected to not trip for a stable power swing having a system separation angle of up to 120 degrees with the sending-end and receiving-end voltages varying from 0.7 to 1.0 per unit (See Guidelines and Technical Basis).

## A. Introduction

1. **Title:** Relay Performance During Stable Power Swings
2. **Number:** PRC-026-~~21~~
3. **Purpose:** To ensure that load-responsive protective relays are expected to not trip in response to stable power swings during non-Fault conditions.
4. **Applicability:**
  - 4.1. **Functional Entities:**
    - 4.1.1 Generator Owner that applies load-responsive protective relays as described in PRC-026-~~12~~ – Attachment A at the terminals of the Elements listed in Section 4.2, Facilities.
    - 4.1.2 Planning Coordinator.
    - 4.1.3 Transmission Owner that applies load-responsive protective relays as described in PRC-026-~~12~~ – Attachment A at the terminals of the Elements listed in Section 4.2, Facilities.
  - 4.2. **Facilities:** The following Elements that are part of the Bulk Electric System (BES):
    - 4.2.1 Generators.
    - 4.2.2 Transformers.
    - 4.2.3 Transmission lines.
5. **Background:**

This is the third phase of a three-phased standard development project that focused on developing this new Reliability Standard to address protective relay operations due to stable power swings. The March 18, 2010, Federal Energy Regulatory Commission (FERC) Order No. 733 approved Reliability Standard PRC-023-1 – Transmission Relay Loadability. In that Order, FERC directed NERC to address three areas of relay loadability that include modifications to the approved PRC-023-1, development of a new Reliability Standard to address generator protective relay loadability, and a new Reliability Standard to address the operation of protective relays due to stable power swings. This project's SAR addresses these directives with a three-phased approach to standard development.

Phase 1 focused on making the specific modifications from FERC Order No. 733 to PRC-023-1. Reliability Standard PRC-023-2, which incorporated these modifications, became mandatory on July 1, 2012.

Phase 2 focused on developing a new Reliability Standard, PRC-025-1 – Generator Relay Loadability, to address generator protective relay loadability. PRC-025-1 became mandatory on October 1, 2014, along with PRC-023-3, which was modified to harmonize PRC-023-2 with PRC-025-1.

Phase 3 focuses on preventing protective relays from tripping unnecessarily due to stable power swings by requiring identification of Elements on which a stable or unstable power swing may affect Protection System operation, assessment of the security of load-

responsive protective relays to tripping in response to only a stable power swing, and implementation of Corrective Action Plans (CAP), where necessary. Phase 3 improves security of load-responsive protective relays for stable power swings so they are expected to not trip in response to stable power swings during non-Fault conditions while maintaining dependable fault detection and dependable out-of-step tripping.

**6. Effective Dates: See Implementation Plan**

**~~Requirement R1~~**

~~First day of the first full calendar year that is 12 months after the date that the standard is approved by an applicable governmental authority or as otherwise provided for in a jurisdiction where approval by an applicable governmental authority is required for a standard to go into effect. Where approval by an applicable governmental authority is not required, the standard shall become effective on the first day of the first full calendar year that is 12 months after the date the standard is adopted by the NERC Board of Trustees or as otherwise provided for in that jurisdiction.~~

**~~Requirements R2, R3, and R4~~**

~~First day of the first full calendar year that is 36 months after the date that the standard is approved by an applicable governmental authority or as otherwise provided for in a jurisdiction where approval by an applicable governmental authority is required for a standard to go into effect. Where approval by an applicable governmental authority is not required, the standard shall become effective on the first day of the first full calendar year that is 36 months after the date the standard is adopted by the NERC Board of Trustees or as otherwise provided for in that jurisdiction.~~

## B. Requirements and Measures

**R1.** Each Planning Coordinator shall, at least once each calendar year, provide notification of each generator, transformer, and transmission line BES Element in its area that meets one or more of the following criteria, if any, to the respective Generator Owner and Transmission Owner: [*Violation Risk Factor: Medium*] [*Time Horizon: Long-term Planning*]

Criteria:

1. Generator(s) where an angular stability constraint, identified in Planning Assessments of the Near-Term Transmission Planning Horizon for a planning event, ~~exists~~ that is addressed by ~~a~~ limiting the output of a generator System Operating Limit (SOL) or a Remedial Action Scheme (RAS), and those Elements terminating at the Transmission station associated with the generator(s).
2. ~~An Elements associated with that is monitored as part of an SOL identified by the Planning Coordinator's methodology<sup>+</sup> based on an~~ angular instability identified in Planning Assessments of the Near-Term Transmission Planning Horizon for a planning event. ~~constraint.~~
3. An Element that forms the boundary of an island in the most recent underfrequency load shedding (UFLS) design assessment based on application of the Planning Coordinator's criteria for identifying islands, only if the island is formed by tripping the Element due to angular instability.
4. An Element identified in the most recent annual Planning Assessment of the Near-Term Transmission Planning Horizon where relay tripping occurs due to a stable or unstable<sup>2</sup> power swing during a simulated disturbance for a planning event.

**M1.** Each Planning Coordinator shall have dated evidence that demonstrates notification of the generator, transformer, and transmission line BES Element(s) that meet one or more of the criteria in Requirement R1, if any, to the respective Generator Owner and Transmission Owner. Evidence may include, but is not limited to, the following documentation: emails, facsimiles, records, reports, transmittals, lists, or spreadsheets.

---

~~<sup>+</sup>NERC Reliability Standard FAC-014-2 — Establish and Communicate System Operating Limits, Requirement R3.~~

<sup>2</sup> An example of an unstable power swing is provided in the Guidelines and Technical Basis section, "Justification for Including Unstable Power Swings in the Requirements section of the Guidelines and Technical Basis."

- R2.** Each Generator Owner and Transmission Owner shall: [Violation Risk Factor: High] [Time Horizon: Operations Planning]
- 2.1** Within 12 full calendar months of notification of a BES Element pursuant to Requirement R1, determine whether its load-responsive protective relay(s) applied to that BES Element meets the criteria in PRC-026-~~12~~– Attachment B where an evaluation of that Element’s load-responsive protective relay(s) based on PRC-026-~~12~~– Attachment B criteria has not been performed in the last five calendar years.
- 2.2** Within 12 full calendar months of becoming aware<sup>3</sup> of a generator, transformer, or transmission line BES Element that tripped in response to a stable or unstable<sup>4</sup> power swing due to the operation of its protective relay(s), determine whether its load-responsive protective relay(s) applied to that BES Element meets the criteria in PRC-026-~~12~~– Attachment B.
- M2.** Each Generator Owner and Transmission Owner shall have dated evidence that demonstrates the evaluation was performed according to Requirement R2. Evidence may include, but is not limited to, the following documentation: apparent impedance characteristic plots, email, design drawings, facsimiles, R-X plots, software output, records, reports, transmittals, lists, settings sheets, or spreadsheets.
- R3.** Each Generator Owner and Transmission Owner shall, within six full calendar months of determining a load-responsive protective relay does not meet the PRC-026-~~12~~– Attachment B criteria pursuant to Requirement R2, develop a Corrective Action Plan (CAP) to meet one of the following: [*Violation Risk Factor: Medium*] [*Time Horizon: Operations Planning*]
- The Protection System meets the PRC-026-~~12~~– Attachment B criteria, while maintaining dependable fault detection and dependable out-of-step tripping (if out-of-step tripping is applied at the terminal of the BES Element); or
  - The Protection System is excluded under the PRC-026-~~12~~– Attachment A criteria (e.g., modifying the Protection System so that relay functions are supervised by power swing blocking or using relay systems that are immune to power swings), while maintaining dependable fault detection and dependable out-of-step tripping (if out-of-step tripping is applied at the terminal of the BES Element).
- M3.** The Generator Owner and Transmission Owner shall have dated evidence that demonstrates the development of a CAP in accordance with Requirement R3. Evidence may include, but is not limited to, the following documentation: corrective action plans, maintenance records, settings sheets, project or work management program records, or work orders.
- R4.** Each Generator Owner and Transmission Owner shall implement each CAP developed pursuant to Requirement R3 and update each CAP if actions or timetables change until all actions are complete. [*Violation Risk Factor: Medium*][*Time Horizon: Long-Term Planning*]

- M4.** The Generator Owner and Transmission Owner shall have dated evidence that demonstrates implementation of each CAP according to Requirement R4, including updates to the CAP when actions or timetables change. Evidence may include, but is not limited to, the following documentation: corrective action plans, maintenance records, settings sheets, project or work management program records, or work orders.

## C. Compliance

### 1. Compliance Monitoring Process

#### 1.1. Compliance Enforcement Authority

As defined in the NERC Rules of Procedure, “Compliance Enforcement Authority” (CEA) means NERC or the Regional Entity in their respective roles of monitoring and enforcing compliance with the NERC Reliability Standards.

#### 1.2. Evidence Retention

The following evidence retention periods identify the period of time an entity is required to retain specific evidence to demonstrate compliance. For instances where the evidence retention period specified below is shorter than the time since the last audit, the CEA may ask an entity to provide other evidence to show that it was compliant for the full time period since the last audit.

The Generator Owner, Planning Coordinator, and Transmission Owner shall keep data or evidence to show compliance as identified below unless directed by its CEA to retain specific evidence for a longer period of time as part of an investigation.

- The Planning Coordinator shall retain evidence of Requirement R1 for a minimum of one calendar year following the completion of the Requirement.
- The Generator Owner and Transmission Owner shall retain evidence of Requirement R2 evaluation for a minimum of 12 calendar months following completion of each evaluation where a CAP is not developed.
- The Generator Owner and Transmission Owner shall retain evidence of Requirements R2, R3, and R4 for a minimum of 12 calendar months following completion of each CAP.

If a Generator Owner, Planning Coordinator, or Transmission Owner is found non-compliant, it shall keep information related to the non-compliance until mitigation is complete and approved, or for the time specified above, whichever is longer.

The CEA shall keep the last audit records and all requested and submitted subsequent audit records.

---

<sup>3</sup> Some examples of the ways an entity may become aware of a power swing are provided in the Guidelines and Technical Basis section, “Becoming Aware of an Element That Tripped in Response to a Power Swing.”

<sup>4</sup> An example of an unstable power swing is provided in the Guidelines and Technical Basis section, “Justification for Including Unstable Power Swings in the Requirements section of the Guidelines and Technical Basis.”

**1.3. Compliance Monitoring and Assessment Processes:**

As defined in the NERC Rules of Procedure; “Compliance Monitoring and Assessment Processes” refers to the identification of the processes that will be used to evaluate data or information for the purpose of assessing performance or outcomes with the associated reliability standard.

**1.4. Additional Compliance Information**

None.



Table of Compliance Elements

R#	Time Horizon	VRF	Violation Severity Levels			
			Lower VSL	Moderate VSL	High VSL	Severe VSL
R1	Long-term Planning	Medium	The Planning Coordinator provided notification of the BES Element(s) in accordance with Requirement R1, but was less than or equal to 30 calendar days late.	The Planning Coordinator provided notification of the BES Element(s) in accordance with Requirement R1, but was more than 30 calendar days and less than or equal to 60 calendar days late.	The Planning Coordinator provided notification of the BES Element(s) in accordance with Requirement R1, but was more than 60 calendar days and less than or equal to 90 calendar days late.	The Planning Coordinator provided notification of the BES Element(s) in accordance with Requirement R1, but was more than 90 calendar days late.  OR  The Planning Coordinator failed to provide notification of the BES Element(s) in accordance with Requirement R1.

R#	Time Horizon	VRF	Violation Severity Levels			
			Lower VSL	Moderate VSL	High VSL	Severe VSL
<b>R2</b>	Operations Planning	High	The Generator Owner or Transmission Owner evaluated its load-responsive protective relay(s) in accordance with Requirement R2, but was less than or equal to 30 calendar days late.	The Generator Owner or Transmission Owner evaluated its load-responsive protective relay(s) in accordance with Requirement R2, but was more than 30 calendar days and less than or equal to 60 calendar days late.	The Generator Owner or Transmission Owner evaluated its load-responsive protective relay(s) in accordance with Requirement R2, but was more than 60 calendar days and less than or equal to 90 calendar days late.	The Generator Owner or Transmission Owner evaluated its load-responsive protective relay(s) in accordance with Requirement R2, but was more than 90 calendar days late.  OR The Generator Owner or Transmission Owner failed to evaluate its load-responsive protective relay(s) in accordance with Requirement R2.

R#	Time Horizon	VRF	Violation Severity Levels			
			Lower VSL	Moderate VSL	High VSL	Severe VSL
<b>R3</b>	Long-term Planning	Medium	The Generator Owner or Transmission Owner developed a Corrective Action Plan (CAP) in accordance with Requirement R3, but in more than six calendar months and less than or equal to seven calendar months.	The Generator Owner or Transmission Owner developed a Corrective Action Plan (CAP) in accordance with Requirement R3, but in more than seven calendar months and less than or equal to eight calendar months.	The Generator Owner or Transmission Owner developed a Corrective Action Plan (CAP) in accordance with Requirement R3, but in more than eight calendar months and less than or equal to nine calendar months.	The Generator Owner or Transmission Owner developed a Corrective Action Plan (CAP) in accordance with Requirement R3, but in more than nine calendar months.  OR The Generator Owner or Transmission Owner failed to develop a CAP in accordance with Requirement R3.
<b>R4</b>	Long-term Planning	Medium	The Generator Owner or Transmission Owner implemented a Corrective Action Plan (CAP), but failed to update a CAP when actions or timetables changed, in accordance with Requirement R4.	N/A	N/A	The Generator Owner or Transmission Owner failed to implement a Corrective Action Plan (CAP) in accordance with Requirement R4.

#### D. Regional Variances

None.

#### E. Interpretations

None.

#### F. Associated Documents

*Applied Protective Relaying*, Westinghouse Electric Corporation, 1979.

Burdy, John, *Loss-of-excitation Protection for Synchronous Generators GER-3183*, General Electric Company.

IEEE Power System Relaying Committee WG D6, *Power Swing and Out-of-Step Considerations on Transmission Lines*, July 2005: <http://www.pes-psrc.org/Reports/Power%20Swing%20and%20OOS%20Considerations%20on%20Transmission%20Lines%20F..pdf>.

Kimbark Edward Wilson, *Power System Stability, Volume II: Power Circuit Breakers and Protective Relays*, Published by John Wiley and Sons, 1950.

Kundur, Prabha, *Power System Stability and Control*, 1994, Palo Alto: EPRI, McGraw Hill, Inc.

NERC System Protection and Control Subcommittee, *Protection System Response to Power Swings*, August 2013: [http://www.nerc.com/comm/PC/System%20Protection%20and%20Control%20Subcommittee%20SPCS%2020/SPCS%20Power%20Swing%20Report\\_Final\\_20131015.pdf](http://www.nerc.com/comm/PC/System%20Protection%20and%20Control%20Subcommittee%20SPCS%2020/SPCS%20Power%20Swing%20Report_Final_20131015.pdf).

Reimert, Donald, *Protective Relaying for Power Generation Systems*, 2006, Boca Raton: CRC Press.

#### Version History

Version	Date	Action	Change Tracking
1	November 13, 2014	Adopted by NERC Board of Trustees	New
1	March 17, 2016	FERC Order issued approving PRC-026-1. Docket No. RM15-8-000.	

Version	Date	Action	Change Tracking
2	May 13, 2021	Adopted by NERC Board of Trustees	Revised under Project 2015-09

### PRC-026-1~~2~~ – Attachment A

This standard applies to any protective functions which could trip instantaneously or with a time delay of less than 15 cycles on load current (i.e., “load-responsive”) including, but not limited to:

- Phase distance
- Phase overcurrent
- Out-of-step tripping
- Loss-of-field

The following protection functions are excluded from Requirements of this standard:

- Relay elements supervised by power swing blocking
- Relay elements that are only enabled when other relays or associated systems fail. For example:
  - Overcurrent elements that are only enabled during loss of potential conditions.
  - Relay elements that are only enabled during a loss of communications
- Thermal emulation relays which are used in conjunction with dynamic Facility Ratings
- Relay elements associated with direct current (dc) lines
- Relay elements associated with dc converter transformers
- Phase fault detector relay elements employed to supervise other load-responsive phase distance elements (i.e., in order to prevent false operation in the event of a loss of potential)
- Relay elements associated with switch-onto-fault schemes
- Reverse power relay on the generator
- Generator relay elements that are armed only when the generator is disconnected from the system, (e.g., non-directional overcurrent elements used in conjunction with inadvertent energization schemes, and open breaker flashover schemes)
- Current differential relay, pilot wire relay, and phase comparison relay
- Voltage-restrained or voltage-controlled overcurrent relays

**PRC-026-12 – Attachment B**

Criterion A:

An impedance-based relay used for tripping is expected to not trip for a stable power swing, when the relay characteristic is completely contained within the unstable power swing region.<sup>5</sup> The unstable power swing region is formed by the union of three shapes in the impedance (R-X) plane; (1) a lower loss-of-synchronism circle based on a ratio of the sending-end to receiving-end voltages of 0.7; (2) an upper loss-of-synchronism circle based on a ratio of the sending-end to receiving-end voltages of 1.43; (3) a lens that connects the endpoints of the total system impedance (with the parallel transfer impedance removed) bounded by varying the sending-end and receiving-end voltages from 0.0 to 1.0 per unit, while maintaining a constant system separation angle across the total system impedance where:

1. The system separation angle is:
  - At least 120 degrees, or
  - An angle less than 120 degrees where a documented transient stability analysis demonstrates that the expected maximum stable separation angle is less than 120 degrees.
2. All generation is in service and all transmission BES Elements are in their normal operating state when calculating the system impedance.
3. Saturated (transient or sub-transient) reactance is used for all machines.

---

<sup>5</sup> Guidelines and Technical Basis, Figures 1 and 2.

**PRC-026-12 – Attachment B**

Criterion B:

The pickup of an overcurrent relay element used for tripping, that is above the calculated current value (with the parallel transfer impedance removed) for the conditions below:

1. The system separation angle is:
  - At least 120 degrees, or
  - An angle less than 120 degrees where a documented transient stability analysis demonstrates that the expected maximum stable separation angle is less than 120 degrees.
2. All generation is in service and all transmission BES Elements are in their normal operating state when calculating the system impedance.
3. Saturated (transient or sub-transient) reactance is used for all machines.
4. Both the sending-end and receiving-end voltages at 1.05 per unit.



## Guidelines and Technical Basis

### Introduction

The NERC System Protection and Control Subcommittee technical document, *Protection System Response to Power Swings*, August 2013,<sup>6</sup> (“PSRPS Report” or “report”) was specifically prepared to support the development of this NERC Reliability Standard. The report provided a historical perspective on power swings as early as 1965 up through the approval of the report by the NERC Planning Committee. The report also addresses reliability issues regarding trade-offs between security and dependability of Protection Systems, considerations for this NERC Reliability Standard, and a collection of technical information about power swing characteristics and varying issues with practical applications and approaches to power swings. Of these topics, the report suggests an approach for this NERC Reliability Standard (“standard” or “~~PRC-026-1~~PRC-026-2”) which is consistent with addressing three regulatory directives in the FERC Order No. 733. The first directive concerns the need for “...protective relay systems that differentiate between faults and stable power swings and, when necessary, phases out protective relay systems that cannot meet this requirement.”<sup>7</sup> Second, is “...to develop a Reliability Standard addressing undesirable relay operation due to stable power swings.”<sup>8</sup> The third directive “...to consider “islanding” strategies that achieve the fundamental performance for all islands in developing the new Reliability Standard addressing stable power swings”<sup>9</sup> was considered during development of the standard.

The development of this standard implements the majority of the approaches suggested by the report. However, it is noted that the Reliability Coordinator and Transmission Planner have not been included in the standard’s Applicability section (as suggested by the PSRPS Report). This is so that a single entity, the Planning Coordinator, may be the single source for identifying Elements according to Requirement R1. A single source will insure that multiple entities will not identify Elements in duplicate, nor will one entity fail to provide an Element because it believes the Element is being provided by another entity. The Planning Coordinator has, or has access to, the wide-area model and can correctly identify the Elements that may be susceptible to a stable or unstable power swing. Additionally, not including the Reliability Coordinator and Transmission Planner is consistent with the applicability of other relay loadability NERC Reliability Standards (e.g., PRC-023 and PRC-025). It is also consistent with the NERC Functional Model.

The phrase, “while maintaining dependable fault detection and dependable out-of-step tripping” in Requirement R3, describes that the Generator Owner and Transmission Owner are to comply with this standard while achieving its desired protection goals. Load-responsive protective relays, as addressed within this standard, may be intended to provide a variety of backup protection functions, both within the generating unit or generating plant and on the transmission system, and

---

<sup>6</sup> NERC System Protection and Control Subcommittee, *Protection System Response to Power Swings*, August 2013: [http://www.nerc.com/comm/PC/System%20Protection%20and%20Control%20Subcommittee%20SPCS%2020/SPCS%20Power%20Swing%20Report\\_Final\\_20131015.pdf](http://www.nerc.com/comm/PC/System%20Protection%20and%20Control%20Subcommittee%20SPCS%2020/SPCS%20Power%20Swing%20Report_Final_20131015.pdf)

<sup>7</sup> Transmission Relay Loadability Reliability Standard, Order No. 733, P.150 FERC ¶ 61,221 (2010).

<sup>8</sup> Ibid. P.153.

<sup>9</sup> Ibid. P.162.

this standard is not intended to result in the loss of these protection functions. Instead, the Generator Owner and Transmission Owner must consider both the Requirements within this standard and its desired protection goals and perform modifications to its protective relays or protection philosophies as necessary to achieve both.

## **Power Swings**

The IEEE Power System Relaying Committee WG D6 developed a technical document called *Power Swing and Out-of-Step Considerations on Transmission Lines* (July 2005) that provides background on power swings. The following are general definitions from that document:<sup>10</sup>

**Power Swing:** a variation in three phase power flow which occurs when the generator rotor angles are advancing or retarding relative to each other in response to changes in load magnitude and direction, line switching, loss of generation, faults, and other system disturbances.

**Pole Slip:** a condition whereby a generator, or group of generators, terminal voltage angles (or phases) go past 180 degrees with respect to the rest of the connected power system.

**Stable Power Swing:** a power swing is considered stable if the generators do not slip poles and the system reaches a new state of equilibrium, i.e. an acceptable operating condition.

**Unstable Power Swing:** a power swing that will result in a generator or group of generators experiencing pole slipping for which some corrective action must be taken.

**Out-of-Step Condition:** Same as an unstable power swing.

**Electrical System Center or Voltage Zero:** it is the point or points in the system where the voltage becomes zero during an unstable power swing.

## **Burden to Entities**

The PSRPS Report provides a technical basis and approach for focusing on Protection Systems, which are susceptible to power swings, while achieving the purpose of the standard. The approach reduces the number of relays to which the PRC-026-~~12~~ Requirements would apply by first identifying the BES Element(s) on which load-responsive protective relays must be evaluated. The first step uses criteria to identify the Elements on which a Protection System is expected to be challenged by power swings. Of those Elements, the second step is to evaluate each load-responsive protective relay that is applied on each identified Element. Rather than requiring the Planning Coordinator or Transmission Planner to perform simulations to obtain information for each identified Element, the Generator Owner and Transmission Owner will reduce the need for simulation by comparing the load-responsive protective relay characteristic to specific criteria in PRC-026-~~12~~ – Attachment B.

---

<sup>10</sup> <http://www.pes-psrc.org/Reports/Power%20Swing%20and%20OOS%20Considerations%20on%20Transmission%20Lines%20F..pdf>.

## Applicability

The standard is applicable to the Generator Owner, Planning Coordinator, and Transmission Owner entities. More specifically, the Generator Owner and Transmission Owner entities are applicable when applying load-responsive protective relays at the terminals of the applicable BES Elements. The standard is applicable to the following BES Elements: generators, transformers, and transmission lines. The Distribution Provider was considered for inclusion in the standard; however, it is not subject to the standard because this entity, by functional registration, would not own generators, transmission lines, or transformers other than load serving.

Load-responsive protective relays include any protective functions which could trip with or without time delay, on load current.

## Requirement R1

The Planning Coordinator has a wide-area view and is in the position to identify what, if any, Elements meet the criteria. The criterion-based approach is consistent with the NERC System Protection and Control Subcommittee (SPCS) technical document, *Protection System Response to Power Swings* (August 2013),<sup>11</sup> which recommends a focused approach to determine an at-risk Element. Identification of Elements comes from the annual Planning Assessments pursuant to the transmission planning (i.e., “TPL”) and other NERC Reliability Standards (e.g., PRC-006), and the standard is not requiring any other assessments to be performed by the Planning Coordinator. The required notification on a calendar year basis to the respective Generator Owner and Transmission Owner is sufficient because it is expected that the Planning Coordinator will make its notifications following the completion of its annual Planning Assessments. The Planning Coordinator will continue to provide notification of Elements on a calendar year basis even if a study is performed less frequently (e.g., PRC-006 – Automatic Underfrequency Load Shedding, which is five years) and has not changed. It is possible that a Planning Coordinator could utilize studies from a prior year in determining the necessary notifications pursuant to Requirement R1.

## Criterion 1

The first criterion involves generator(s) where an angular stability constraint exists that is addressed by ~~limiting the output of a generator~~ ~~System Operating Limit (SOL)~~ or a Remedial Action Scheme (RAS) and those Elements terminating at the Transmission station associated with the generator(s). For example, a scheme to remove generation for specific conditions is implemented for a four-unit generating plant (1,100 MW). Two of the units are 500 MW each; one is connected to the 345 kV system and one is connected to the 230 kV system. The Transmission Owner has two 230 kV transmission lines and one 345 kV transmission line all terminating at the generating facility as well as a 345/230 kV autotransformer. The remaining 100 MW consists of two 50 MW combustion turbine (CT) units connected to four 66 kV transmission lines. The 66 kV transmission lines are not electrically joined to the 345 kV and 230 kV transmission lines at the plant site and are not subject to ~~the operating limit~~ ~~any generating output limitation~~ or RAS. A

---

<sup>11</sup> [http://www.nerc.com/comm/PC/System%20Protection%20and%20Control%20Subcommittee%20SPCS%2020/SPCS%20Power%20Swing%20Report\\_Final\\_20131015.pdf](http://www.nerc.com/comm/PC/System%20Protection%20and%20Control%20Subcommittee%20SPCS%2020/SPCS%20Power%20Swing%20Report_Final_20131015.pdf)

stability constraint limits the output of the portion of the plant affected by the RAS to 700 MW for an outage of the 345 kV transmission line. The RAS trips one of the 500 MW units to maintain stability for a loss of the 345 kV transmission line when the total output from both 500 MW units is above 700 MW. For this example, both 500 MW generating units and the associated generator step-up (GSU) transformers would be identified as Elements meeting this criterion. The 345/230 kV autotransformer, the 345 kV transmission line, and the two 230 kV transmission lines would also be identified as Elements meeting this criterion. The 50 MW combustion turbines and 66 kV transmission lines would not be identified pursuant to Criterion 1 because these Elements are not subject to ~~an operating limit~~ any generating output limitation or RAS and do not terminate at the Transmission station associated with the generators that are subject to any generating output limitation~~the SOL~~ or RAS.

## **Criterion 2**

The second criterion involves Elements associated with angular instability identified in the Planning Assessments~~that are monitored as a part of an established System Operating Limit (SOL) based on an angular stability limit regardless of the outage conditions that result in the enforcement of the SOL~~. For example, if Planning Assessments have identified that an angular instability could limit transfer capability on two long parallel 500 kV transmission lines ~~have a combined SOL of to a maximum of~~ 1,200 MW, and this limitation is based on angular instability resulting from a fault and subsequent loss of one of the two lines, then both lines would be identified as Elements meeting the criterion.

## **Criterion 3**

The third criterion involves Elements that form the boundary of an island within an underfrequency load shedding (UFLS) design assessment. The criterion applies to islands identified based on application of the Planning Coordinator’s criteria for identifying islands, where the island is formed by tripping the Elements based on angular instability. The criterion applies if the angular instability is modeled in the UFLS design assessment, or if the boundary is identified “off-line” (i.e., the Elements are selected based on angular instability considerations, but the Elements are tripped in the UFLS design assessment without modeling the initiating angular instability). In cases where an out-of-step condition is detected and tripping is initiated at an alternate location, the criterion applies to the Element on which the power swing is detected. The criterion does not apply to islands identified based on other considerations that do not involve angular instability, such as excessive loading, Planning Coordinator area boundary tie lines, or Balancing Authority boundary tie lines.

## **Criterion 4**

The fourth criterion involves Elements identified in the most recent annual Planning Assessment where relay tripping occurs due to a stable or unstable<sup>12</sup> power swing during a simulated

---

<sup>12</sup> Refer to the “Justification for Including Unstable Power Swings in the Requirements” section.

disturbance. The intent is for the Planning Coordinator to include any Element(s) where relay tripping was observed during simulations performed for the most recent annual Planning Assessment associated with the transmission planning TPL-001-4 Reliability Standard. Note that relay tripping must be assessed within those annual Planning Assessments per TPL-001-4, R4, Part 4.3.1.3, which indicates that analysis shall include the “Tripping of Transmission lines and transformers where transient swings cause Protection System operation based on generic or actual relay models.” Identifying such Elements according to Criterion 4 and notifying the respective Generator Owner and Transmission Owner will require that the owners of any load-responsive protective relay applied at the terminals of the identified Element evaluate the relay’s susceptibility to tripping in response to a stable power swing.

Planning Coordinators have the discretion to determine whether the observed tripping for a power swing in its Planning Assessments occurs for valid contingencies and system conditions. The Planning Coordinator will address tripping that is observed in transient analyses on an individual basis; therefore, the Planning Coordinator is responsible for identifying the Elements based only on simulation results that are determined to be valid.

Due to the nature of how a Planning Assessment is performed, there may be cases where a previously-identified Element is not identified in the most recent annual Planning Assessment. If so, this is acceptable because the Generator Owner and Transmission Owner would have taken action upon the initial notification of the previously identified Element. When an Element is not identified in later Planning Assessments, the risk of load-responsive protective relays tripping in response to a stable power swing during non-Fault conditions would have already been assessed under Requirement R2 and mitigated according to Requirements R3 and R4 where the relays did not meet the ~~PRC-026-1~~2 – Attachment B criteria. According to Requirement R2, the Generator Owner and Transmission Owner are only required to re-evaluate each load-responsive protective relay for an identified Element where the evaluation has not been performed in the last five calendar years.

Although Requirement R1 requires the Planning Coordinator to notify the respective Generator Owner and Transmission Owner of any Elements meeting one or more of the four criteria, it does not preclude the Planning Coordinator from providing additional information, such as apparent impedance characteristics, in advance or upon request, that may be useful in evaluating protective relays. Generator Owners and Transmission Owners are able to complete protective relay evaluations and perform the required actions without additional information. The standard does not include any requirement for the entities to provide information that is already being shared or exchanged between entities for operating needs. While a Requirement has not been included for the exchange of information, entities should recognize that relay performance needs to be measured against the most current information.

## **Requirement R2**

Requirement R2 requires the Generator Owner and Transmission Owner to evaluate its load-responsive protective relays to ensure that they are expected to not trip in response to stable power swings.

The PRC-026-~~1~~-2 – Attachment A lists the applicable load-responsive relays that must be evaluated which include phase distance, phase overcurrent, out-of-step tripping, and loss-of-field relay functions. Phase distance relays could include, but are not limited to, the following:

- Zone elements with instantaneous tripping or intentional time delays of less than 15 cycles
- Phase distance elements used in high-speed communication-aided tripping schemes including:
  - Directional Comparison Blocking (DCB) schemes
  - Directional Comparison Un-Blocking (DCUB) schemes
  - Permissive Overreach Transfer Trip (POTT) schemes
  - Permissive Underreach Transfer Trip (PUTT) schemes

A method is provided within the standard to support consistent evaluation by Generator Owners and Transmission Owners based on specified conditions. Once a Generator Owner or Transmission Owner is notified of Elements pursuant to Requirement R1, it has 12 full calendar months to determine if each Element’s load-responsive protective relays meet the PRC-026-~~1~~-2 – Attachment B criteria, if the determination has not been performed in the last five calendar years. Additionally, each Generator Owner and Transmission Owner, that becomes aware of a generator, transformer, or transmission line BES Element that tripped in response to a stable or unstable power swing due to the operation of its protective relays pursuant to Requirement R2, Part 2.2, must perform the same PRC-026-~~1~~-2 – Attachment B criteria determination within 12 full calendar months.

### **Becoming Aware of an Element That Tripped in Response to a Power Swing**

Part 2.2 in Requirement R2 is intended to initiate action by the Generator Owner and Transmission Owner when there is a known stable or unstable power swing and it resulted in the entity’s Element tripping. The criterion starts with becoming aware of the event (i.e., power swing) and then any connection with the entity’s Element tripping. By doing so, the focus is removed from the entity having to demonstrate that it made a determination whether a power swing was present for every Element trip. The basis for structuring the criterion in this manner is driven by the available ways that a Generator Owner and Transmission Owner could become aware of an Element that tripped in response to a stable or unstable power swing due to the operation of its protective relay(s).

Element trips caused by stable or unstable power swings, though infrequent, would be more common in a larger event. The identification of power swings will be revealed during an analysis of the event. Event analysis where an entity may become aware of a stable or unstable power swing could include internal analysis conducted by the entity, the entity’s Protection System review following a trip, or a larger scale analysis by other entities. Event analysis could include involvement by the entity’s Regional Entity, and in some cases NERC.

### **Information Common to Both Generation and Transmission Elements**

The PRC-026-~~1~~-2 – Attachment A lists the load-responsive protective relays that are subject to this standard. Generator Owners and Transmission Owners may own load-responsive protective relays (e.g., distance relays) that directly affect generation or transmission BES Elements and will require analysis as a result of Elements being identified by the Planning Coordinator in Requirement R1



or the Generator Owner or Transmission Owner in Requirement R2. For example, distance relays owned by the Transmission Owner may be installed at the high-voltage side of the generator step-up (GSU) transformer (directional toward the generator) providing backup to generation protection. Generator Owners may have distance relays applied to backup transmission protection or backup protection to the GSU transformer. The Generator Owner may have relays installed at the generator terminals or the high-voltage side of the GSU transformer.

### Exclusion of Time Based Load-Responsive Protective Relays

The purpose of the standard is “[t]o ensure that load-responsive protective relays are expected to not trip in response to stable power swings during non-Fault conditions.” Load-responsive, high-speed tripping protective relays pose the highest risk of operating during a power swing. Because of this, high-speed tripping protective relays and relays with a time delay of less than 15 cycles are included in the standard; whereas other relays (i.e., Zones 2 and 3) with a time delay of 15 cycles or greater are excluded. The time delay used for exclusion on some load-responsive protective relays is based on the maximum expected time that load-responsive protective relays would be exposed to a stable power swing with a slow slip rate frequency.

In order to establish a time delay that distinguishes a high-risk load-responsive protective relay from one that has a time delay for tripping (lower-risk), a sample of swing rates were calculated based on a stable power swing entering and leaving the impedance characteristic as shown in Table 1. For a relay impedance characteristic that has a power swing entering and leaving, beginning at 90 degrees with a termination at 120 degrees before exiting the zone, the zone timer must be greater than the calculated time the stable power swing is inside the relay’s operating zone to not trip in response to the stable power swing.

$$\text{Eq. (1)} \quad \text{Zone timer} > 2 \times \left( \frac{(120^\circ - \text{Angle of entry into the relay characteristic}) \times 60}{(360 \times \text{Slip Rate})} \right)$$

Table 1: Swing Rates	
Zone Timer (Cycles)	Slip Rate (Hz)
10	1.00
15	0.67
20	0.50
30	0.33

With a minimum zone timer of 15 cycles, the corresponding slip rate of the system is 0.67 Hz. This represents an approximation of a slow slip rate during a system Disturbance. Longer time delays allow for slower slip rates.

## Application to Transmission Elements

Criterion A in PRC-026-1-2 – Attachment B describes an unstable power swing region that is formed by the union of three shapes in the impedance (R-X) plane. The first shape is a lower loss-of-synchronism circle based on a ratio of the sending-end to receiving-end voltages of 0.7 (i.e.,  $E_S / E_R = 0.7 / 1.0 = 0.7$ ). The second shape is an upper loss-of-synchronism circle based on a ratio of the sending-end to receiving-end voltages of 1.43 (i.e.,  $E_S / E_R = 1.0 / 0.7 = 1.43$ ). The third shape is a lens that connects the endpoints of the total system impedance together by varying the sending-end and receiving-end system voltages from 0.0 to 1.0 per unit, while maintaining a constant system separation angle across the total system impedance (with the parallel transfer impedance removed—see Figures 1 through 5). The total system impedance is derived from a two-bus equivalent network and is determined by summing the sending-end source impedance, the line impedance (excluding the Thévenin equivalent transfer impedance), and the receiving-end source impedance as shown in Figures 6 and 7. Establishing the total system impedance provides a conservative condition that will maximize the security of the relay against various system conditions. The smallest total system impedance represents a condition where the size of the lens characteristic in the R-X plane is smallest and is a conservative operating point from the standpoint of ensuring a load-responsive protective relay is expected to not trip given a predetermined angular displacement between the sending-end and receiving-end voltages. The smallest total system impedance results when all generation is in service and all transmission BES Elements are modeled in their “normal” system configuration (PRC-026-1-2 – Attachment B, Criterion A). The parallel transfer impedance is removed to represent a likely condition where parallel Elements may be lost during the disturbance, and the loss of these Elements magnifies the sensitivity of the load-responsive relays on the parallel line by removing the “infeed effect” (i.e., the apparent impedance sensed by the relay is decreased as a result of the loss of the transfer impedance, thus making the relay more likely to trip for a stable power swing—See Figures 13 and 14).

The sending-end and receiving-end source voltages are varied from 0.7 to 1.0 per unit to form the lower and upper loss-of-synchronism circles. The ratio of these two voltages is used in the calculation of the loss-of-synchronism circles, and result in a ratio range from 0.7 to 1.43.

$$\text{Eq. (2)} \quad \frac{E_S}{E_R} = \frac{0.7}{1.0} = 0.7$$

$$\text{Eq. (3):} \quad \frac{E_S}{E_R} = \frac{1.0}{0.7} = 1.43$$

The internal generator voltage during severe power swings or transmission system fault conditions will be greater than zero due to voltage regulator support. The voltage ratio of 0.7 to 1.43 is chosen to be more conservative than the PRC-023<sup>13</sup> and PRC-025<sup>14</sup> NERC Reliability Standards where a lower bound voltage of 0.85 per unit voltage is used. A  $\pm 15\%$  internal generator voltage range was chosen as a conservative voltage range for calculation of the voltage ratio used to calculate the loss-of-synchronism circles. For example, the voltage ratio using these voltages would result in a ratio range from 0.739 to 1.353.

<sup>13</sup> Transmission Relay Loadability

<sup>14</sup> Generator Relay Loadability



Eq. (4)  $\frac{E_S}{E_R} = \frac{0.85}{1.15} = 0.739$

Eq. (5):  $\frac{E_S}{E_R} = \frac{1.15}{0.85} = 1.353$

The lower ratio is rounded down to 0.7 to be more conservative, allowing a voltage range of 0.7 to 1.0 per unit to be used for the calculation of the loss-of-synchronism circles.<sup>15</sup>

When the parallel transfer impedance is included in the model, the division of current through the parallel transfer impedance path results in actual measured relay impedances that are larger than those measured when the parallel transfer impedance is removed (i.e., infeed effect), which would make it more likely for an impedance relay element to be completely contained within the unstable power swing region as shown in Figure 11. If the transfer impedance is included in the evaluation, a distance relay element could be deemed as meeting PRC-026-~~1~~2 – Attachment B criteria and, in fact would be secure, assuming all Elements were in their normal state. In this case, the distance relay element could trip in response to a stable power swing during an actual event if the system was weakened (i.e., a higher transfer impedance) by the loss of a subset of lines that make up the parallel transfer impedance as shown in Figure 10. This could happen because the subset of lines that make up the parallel transfer impedance tripped on unstable swings, contained the initiating fault, and/or were lost due to operation of breaker failure or remote back-up protection schemes.

Table 10 shows the percent size increase of the lens shape as seen by the relay under evaluation when the parallel transfer impedance is included. The parallel transfer impedance has minimal effect on the apparent size of the lens shape as long as the parallel transfer impedance is at least 10 multiples of the parallel line impedance (less than 5% lens shape expansion), therefore, its removal has minimal impact, but results in a slightly more conservative, smaller lens shape. Parallel transfer impedances of 5 multiples of the parallel line impedance or less result in an apparent lens shape size of 10% or greater as seen by the relay. If two parallel lines and a parallel transfer impedance tie the sending-end and receiving-end buses together, the total parallel transfer impedance will be one or less multiples of the parallel line impedance, resulting in an apparent lens shape size of 45% or greater. It is a realistic contingency that the parallel line could be out-of-service, leaving the parallel transfer impedance making up the rest of the system in parallel with the line impedance. Since it is not known exactly which lines making up the parallel transfer impedance will be out of service during a major system disturbance, it is most conservative to assume that all of them are out, leaving just the line under evaluation in service.

Either the saturated transient or sub-transient direct axis reactance may be used for machines in the evaluation because they are smaller than the un-saturated reactances. Since saturated sub-transient generator reactances are smaller than the transient or synchronous reactances, the use of sub-transient reactances will result in a smaller source impedance and a smaller unstable power swing region in the graphical analysis as shown in Figures 8 and 9. Because power swings occur in a time frame where generator transient reactances will be prevalent, it is acceptable to use saturated transient reactances instead of saturated sub-transient reactances. Because some short-

---

<sup>15</sup> *Final Report on the August 14, 2003 Blackout in the United States and Canada: Causes and Recommendations*, April 2004, Section 6 (The Cascade Stage of the Blackout), p. 94 under “Why the Generators Tripped Off,” states, “Some generator undervoltage relays were set to trip at or above 90% voltage. However, a motor stalls out at about 70% voltage and a motor starter contactor drops out around 75%, so if there is a compelling need to protect the turbine from the system the under-voltage trigger point should be no higher than 80%.”

circuit models may not include transient reactances, the use of sub-transient reactances is also acceptable because it produces more conservative results. For this reason, either value is acceptable when determining the system source impedances (PRC-026-~~1~~2 – Attachment B, Criterion A and B, No. 3).

Saturated reactances are used in short-circuit programs that produce the system impedance mentioned above. Planning and stability software generally use un-saturated reactances. Generator models used in transient stability analyses recognize that the extent of the saturation effect depends upon both rotor (field) and stator currents. Accordingly, they derive the effective saturated parameters of the machine at each instant by internal calculation from the specified (constant) unsaturated values of machine reactances and the instantaneous internal flux level. The specific assumptions regarding which inductances are affected by saturation, and the relative effect of that saturation, are different for the various generator models used. Thus, unsaturated values of all machine reactances are used in setting up planning and stability software data, and the appropriate set of open-circuit magnetization curve data is provided for each machine.

Saturated reactance values are smaller than unsaturated reactance values and are used in short-circuit programs owned by the Generator and Transmission Owners. Because of this, saturated reactance values are to be used in the development of the system source impedances.

The source or system equivalent impedances can be obtained by a number of different methods using commercially available short-circuit calculation tools.<sup>16</sup> Most short-circuit tools have a network reduction feature that allows the user to select the local and remote terminal buses to retain. The first method reduces the system to one that contains two buses, an equivalent generator at each bus (representing the source impedances at the sending-end and receiving-end), and two parallel lines; one being the line impedance of the protected line with relays being analyzed, the other being the parallel transfer impedance representing all other combinations of lines that connect the two buses together as shown in Figure 6. Another conservative method is to open both ends of the line being evaluated, and apply a three-phase bolted fault at each bus to determine the Thévenin equivalent impedance at each bus. The source impedances are set equal to the Thévenin equivalent impedances and will be less than or equal to the actual source impedances calculated by the network reduction method. Either method can be used to develop the system source impedances at both ends.

The two bullets of PRC-026-~~1~~2 – Attachment B, Criterion A, No. 1, identify the system separation angles used to identify the size of the power swing stability boundary for evaluating load-responsive protective relay impedance elements. The first bullet of PRC-026-~~1~~2 – Attachment B, Criterion A, No. 1 evaluates a system separation angle of at least 120 degrees that is held constant while varying the sending-end and receiving-end source voltages from 0.7 to 1.0 per unit, thus creating an unstable power swing region about the total system impedance in Figure 1. This unstable power swing region is compared to the tripping portion of the distance relay characteristic; that is, the portion that is not supervised by load encroachment, blinders, or some other form of supervision as shown in Figure 12 that restricts the distance element from tripping

---

<sup>16</sup> Demetrios A. Tziouvaras and Daqing Hou, Appendix in *Out-Of-Step Protection Fundamentals and Advancements*, April 17, 2014: <https://www.selinc.com>.

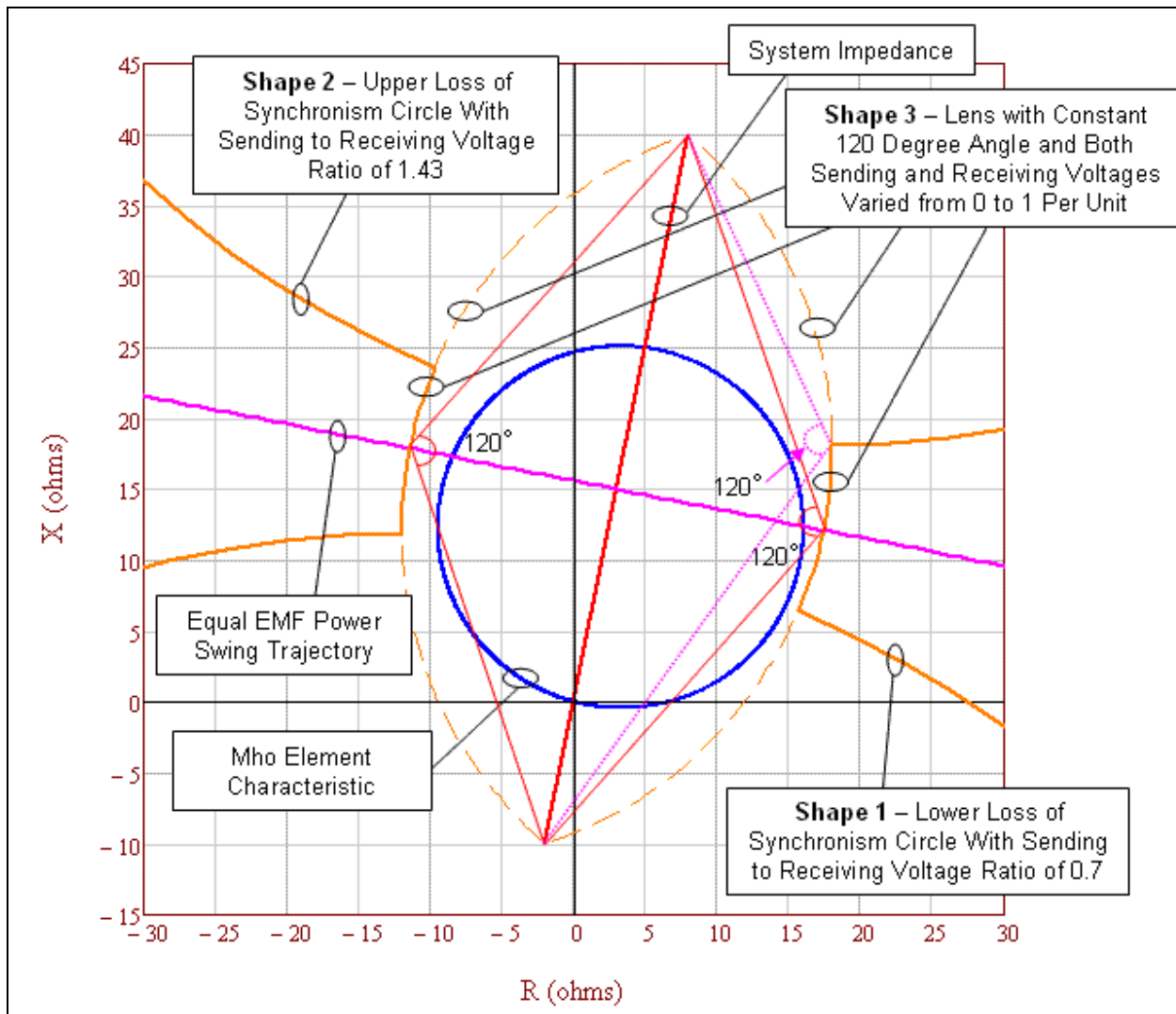
for heavy, balanced load conditions. If the tripping portion of the impedance characteristics are completely contained within the unstable power swing region, the relay impedance element meets Criterion A in PRC-026-~~1~~2– Attachment B. A system separation angle of 120 degrees was chosen for the evaluation because it is generally accepted in the industry that recovery for a swing beyond this angle is unlikely to occur.<sup>17</sup>

The second bullet of PRC-026-~~1~~2– Attachment B, Criterion A, No. 1 evaluates impedance relay elements at a system separation angle of less than 120 degrees, similar to the first bullet described above. An angle less than 120 degrees may be used if a documented stability analysis demonstrates that the power swing becomes unstable at a system separation angle of less than 120 degrees.

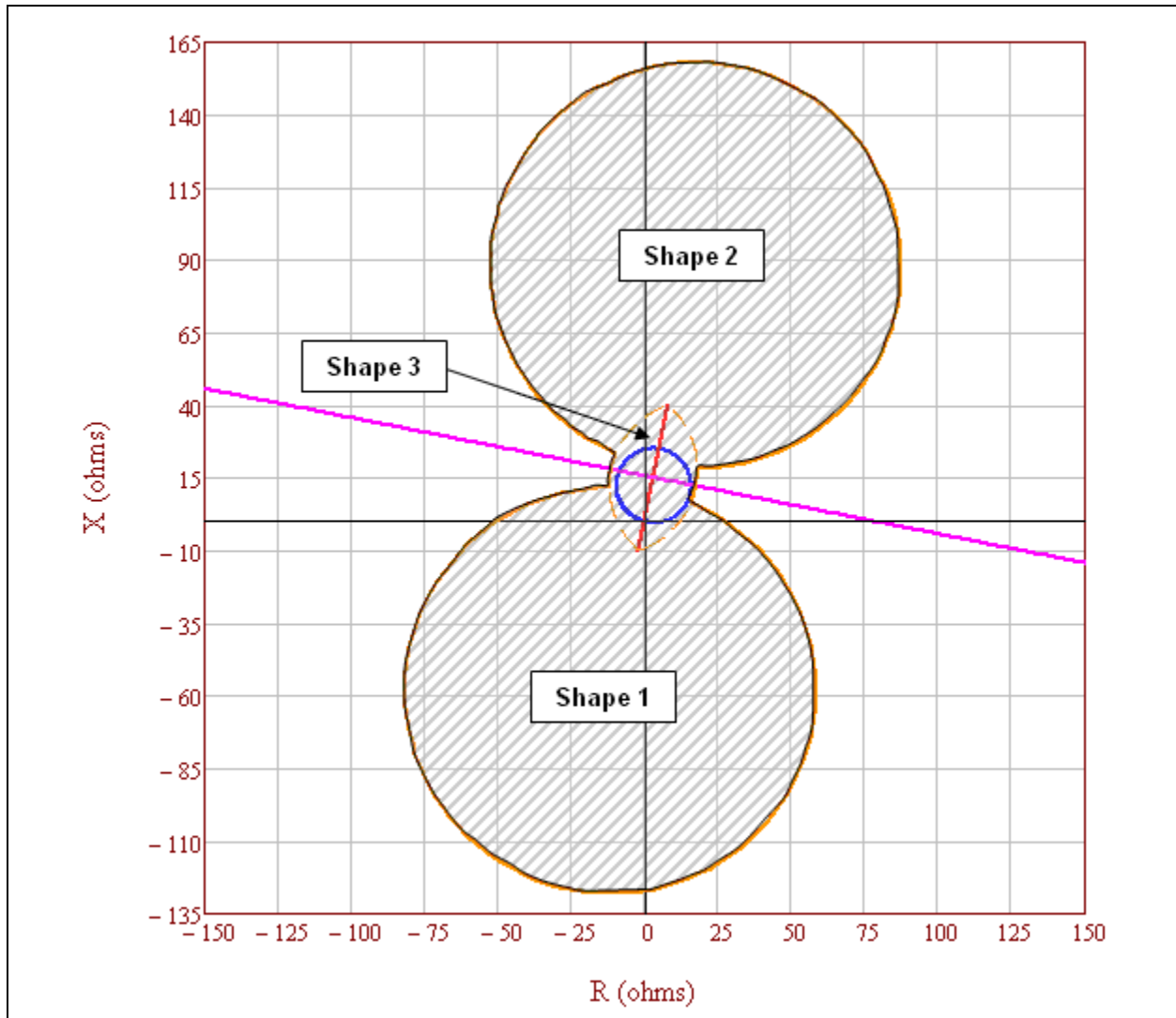
The exclusion of relay elements supervised by Power Swing Blocking (PSB) in PRC-026-~~1~~2– Attachment A allows the Generator Owner or Transmission Owner to exclude protective relay elements if they are blocked from tripping by PSB relays. A PSB relay applied and set according to industry accepted practices prevent supervised load-responsive protective relays from tripping in response to power swings. Further, PSB relays are set to allow dependable tripping of supervised elements. The criteria in PRC-026-~~1~~2– Attachment B specifically applies to unsupervised elements that could trip for stable power swings. Therefore, load-responsive protective relay elements supervised by PSB can be excluded from the Requirements of this standard.

---

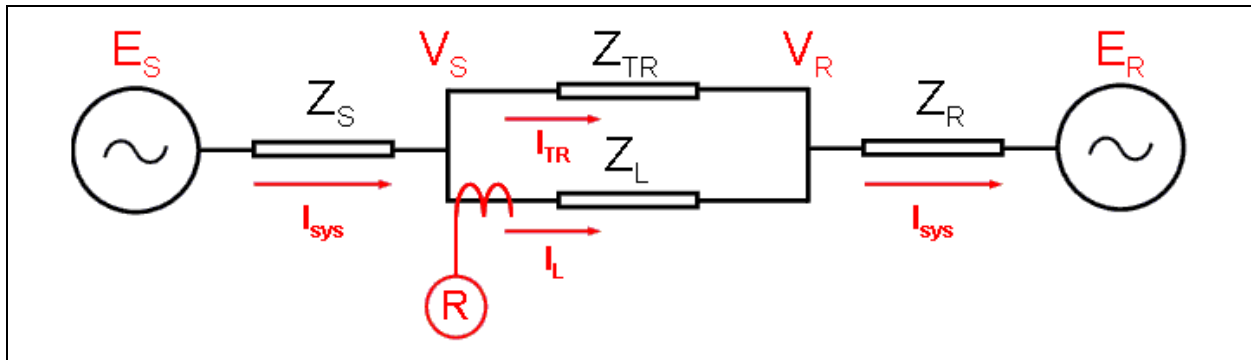
<sup>17</sup> “The critical angle for maintaining stability will vary depending on the contingency and the system condition at the time the contingency occurs; however, the likelihood of recovering from a swing that exceeds 120 degrees is marginal and 120 degrees is generally accepted as an appropriate basis for setting out-of-step protection. Given the importance of separating unstable systems, defining 120 degrees as the critical angle is appropriate to achieve a proper balance between dependable tripping for unstable power swings and secure operation for stable power swings.” NERC System Protection and Control Subcommittee, *Protection System Response to Power Swings*, August 2013: [http://www.nerc.com/comm/PC/System%20Protection%20and%20Control%20Subcommittee%20SPCS%202020/SPCS%20Power%20Swing%20Report\\_Final\\_20131015.pdf](http://www.nerc.com/comm/PC/System%20Protection%20and%20Control%20Subcommittee%20SPCS%202020/SPCS%20Power%20Swing%20Report_Final_20131015.pdf), p. 28.



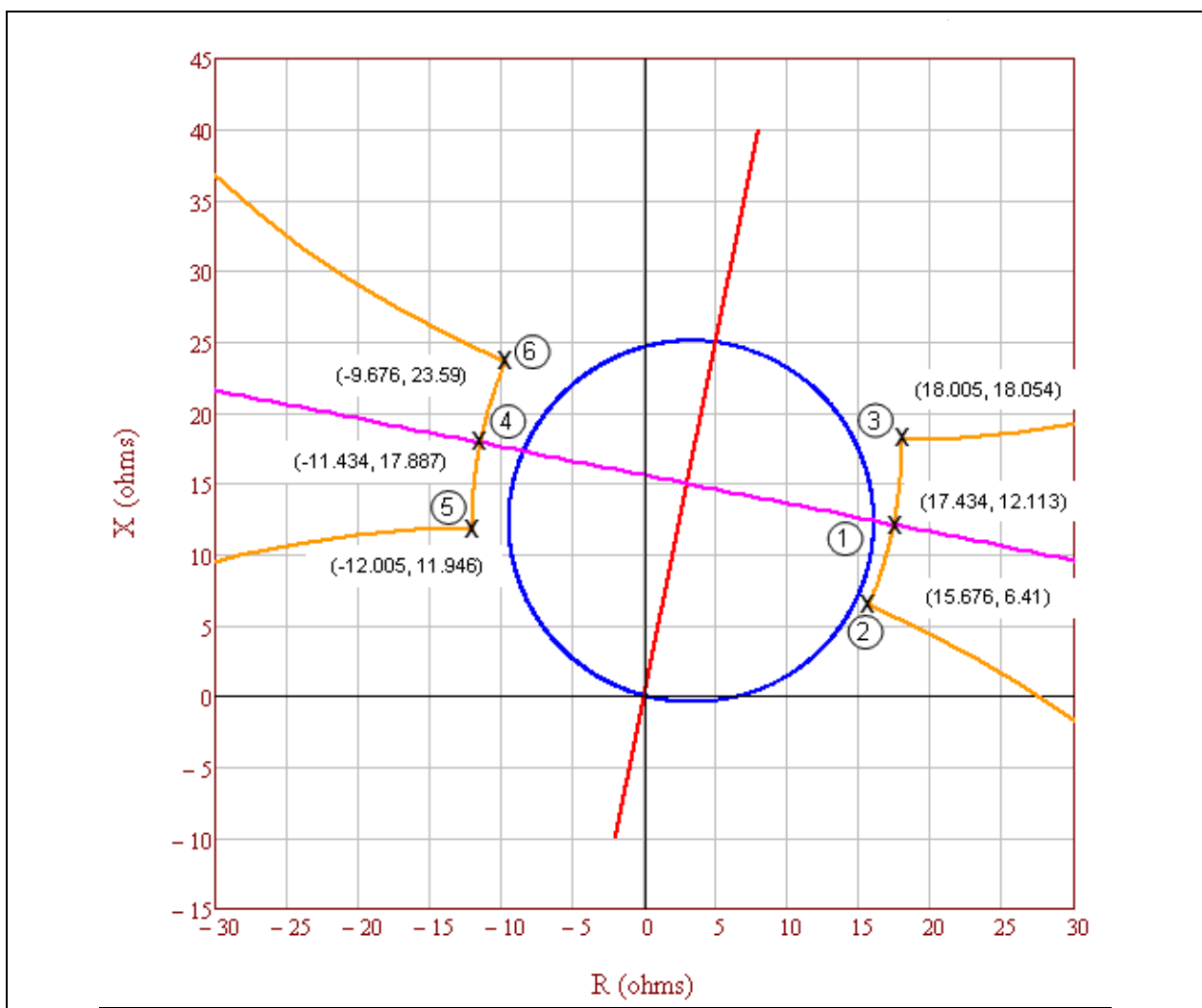
**Figure 1:** An enlarged graphic illustrating the unstable power swing region formed by the union of three shapes in the impedance (R-X) plane: Shape 1) Lower loss-of-synchronism circle, Shape 2) Upper loss-of-synchronism circle, and Shape 3) Lens. The mho element characteristic is completely contained within the unstable power swing region (i.e., it does not intersect any portion of the unstable power swing region), therefore it meets PRC-026-1-2 – Attachment B, Criterion A, No. 1.



**Figure 2:** Full graphic of the unstable power swing region formed by the union of the three shapes in the impedance (R-X) plane: Shape 1) Lower loss-of-synchronism circle, Shape 2) Upper loss-of-synchronism circle, and Shape 3) Lens. The mho element characteristic is completely contained within the unstable power swing region, therefore it meets PRC-26-1 – Attachment B, Criterion A, No.1.



**Figure 3:** System impedances as seen by Relay R (voltage connections are not shown).



**Figure 4:** The defining unstable power swing region points where the lens shape intersects the lower and upper loss-of-synchronism circle shapes and where the lens intersects the equal EMF (electromotive force) power swing.

E <sub>S</sub> / E <sub>R</sub> Voltage Ratio	Left Side Coordinates		Right Side Coordinates	
	R	+ jX	R	+ jX
<b>0.7</b>	<b>-12.005</b>	<b>11.946</b>	<b>15.676</b>	<b>6.41</b>
0.72	-12.004	12.407	15.852	6.836
0.74	-11.996	12.857	16.018	7.255
0.76	-11.982	13.298	16.175	7.667
0.78	-11.961	13.729	16.321	8.073
0.8	-11.935	14.151	16.459	8.472
0.82	-11.903	14.563	16.589	8.865
0.84	-11.867	14.966	16.71	9.251
0.86	-11.826	15.361	16.824	9.631
0.88	-11.78	15.746	16.93	10.004
0.9	-11.731	16.123	17.03	10.371
0.92	-11.678	16.492	17.123	10.732
0.94	-11.621	16.852	17.209	11.086
0.96	-11.562	17.205	17.29	11.435
0.98	-11.499	17.55	17.364	11.777
<b>1</b>	<b>-11.434</b>	<b>17.887</b>	<b>17.434</b>	<b>12.113</b>
1.0286	-11.336	18.356	17.524	12.584
1.0572	-11.234	18.81	17.604	13.043
1.0858	-11.127	19.251	17.675	13.49
1.1144	-11.017	19.677	17.738	13.926
1.143	-10.904	20.091	17.792	14.351
1.1716	-10.788	20.491	17.84	14.766
1.2002	-10.67	20.88	17.88	15.17
1.2288	-10.55	21.256	17.914	15.564
1.2574	-10.428	21.621	17.942	15.948
1.286	-10.304	21.975	17.964	16.322
1.3146	-10.18	22.319	17.981	16.687
1.3432	-10.054	22.652	17.993	17.043
1.3718	-9.928	22.976	18.001	17.39
1.4004	-9.801	23.29	18.005	17.728
<b>1.429</b>	<b>-9.676</b>	<b>23.59</b>	<b>18.005</b>	<b>18.054</b>

**Figure 5:** Full table of 31 detailed lens shape point calculations. The bold highlighted rows correspond to the detailed calculations in Tables 2-7.

Table 2: Example Calculation (Lens Point 1)	
This example is for calculating the impedance the first point of the lens characteristic. Equal source voltages are used for the 230 kV (base) line with the sending-end voltage (E <sub>S</sub> ) leading the receiving-end voltage (E <sub>R</sub> ) by 120 degrees. See Figures 3 and 4.	
Eq. (6)	$E_S = \frac{V_{LL} \angle 120^\circ}{\sqrt{3}}$

Table 2: Example Calculation (Lens Point 1)			
	$E_S = \frac{230,000 \angle 120^\circ V}{\sqrt{3}}$		
	$E_S = 132,791 \angle 120^\circ V$		
Eq. (7)	$E_R = \frac{V_{LL} \angle 0^\circ}{\sqrt{3}}$		
	$E_R = \frac{230,000 \angle 0^\circ V}{\sqrt{3}}$		
	$E_R = 132,791 \angle 0^\circ V$		
Positive sequence impedance data (with transfer impedance $Z_{TR}$ set to a large value).			
Given:	$Z_S = 2 + j10 \Omega$	$Z_L = 4 + j20 \Omega$	$Z_R = 4 + j20 \Omega$
Given:	$Z_{TR} = Z_L \times 10^{10} \Omega$		
Total impedance between the generators.			
Eq. (8)	$Z_{total} = \frac{(Z_L \times Z_{TR})}{(Z_L + Z_{TR})}$		
	$Z_{total} = \frac{((4 + j20) \Omega \times (4 + j20) \times 10^{10} \Omega)}{((4 + j20) \Omega + (4 + j20) \times 10^{10} \Omega)}$		
	$Z_{total} = 4 + j20 \Omega$		
Total system impedance.			
Eq. (9)	$Z_{sys} = Z_S + Z_{total} + Z_R$		
	$Z_{sys} = (2 + j10) \Omega + (4 + j20) \Omega + (4 + j20) \Omega$		
	$Z_{sys} = 10 + j50 \Omega$		
Total system current from sending-end source.			
Eq. (10)	$I_{sys} = \frac{E_S - E_R}{Z_{sys}}$		
	$I_{sys} = \frac{132,791 \angle 120^\circ V - 132,791 \angle 0^\circ V}{(10 + j50) \Omega}$		
	$I_{sys} = 4,511 \angle 71.3^\circ A$		
The current, as measured by the relay on $Z_L$ (Figure 3), is only the current flowing through that line as determined by using the current divider equation.			
Eq. (11)	$I_L = I_{sys} \times \frac{Z_{TR}}{Z_L + Z_{TR}}$		



Table 2: Example Calculation (Lens Point 1)	
	$I_L = 4,511\angle 71.3^\circ A \times \frac{(4 + j20) \times 10^{10} \Omega}{(4 + j20) \Omega + (4 + j20) \times 10^{10} \Omega}$
	$I_L = 4,511\angle 71.3^\circ A$
The voltage, as measured by the relay on $Z_L$ (Figure 3), is the voltage drop from the sending-end source through the sending-end source impedance.	
Eq. (12)	$V_S = E_S - (Z_S \times I_{sys})$
	$V_S = 132,791\angle 120^\circ V - [(2 + j10) \Omega \times 4,511\angle 71.3^\circ A]$
	$V_S = 95,757\angle 106.1^\circ V$
The impedance seen by the relay on $Z_L$ .	
Eq. (13)	$Z_{L-Relay} = \frac{V_S}{I_L}$
	$Z_{L-Relay} = \frac{95,757\angle 106.1^\circ V}{4,511\angle 71.3^\circ A}$
	$Z_{L-Relay} = 17.434 + j12.113 \Omega$

Table 3: Example Calculation (Lens Point 2)	
This example is for calculating the impedance second point of the lens characteristic. Unequal source voltages are used for the 230 kV (base) line with the sending-end voltage ( $E_S$ ) at 70% of the receiving-end voltage ( $E_R$ ) and leading the receiving-end voltage by 120 degrees. See Figures 3 and 4.	
Eq. (14)	$E_S = \frac{V_{LL}\angle 120^\circ}{\sqrt{3}} \times 70\%$
	$E_S = \frac{230,000\angle 120^\circ V}{\sqrt{3}} \times 0.70$
	$E_S = 92,953.7\angle 120^\circ V$
Eq. (15)	$E_R = \frac{V_{LL}\angle 0^\circ}{\sqrt{3}}$
	$E_R = \frac{230,000\angle 0^\circ V}{\sqrt{3}}$
	$E_R = 132,791\angle 0^\circ V$
Positive sequence impedance data (with transfer impedance $Z_{TR}$ set to a large value).	
Given:	$Z_S = 2 + j10 \Omega$ $Z_L = 4 + j20 \Omega$ $Z_R = 4 + j20 \Omega$
Given:	$Z_{TR} = Z_L \times 10^{10} \Omega$

Table 3: Example Calculation (Lens Point 2)	
Total impedance between the generators.	
Eq. (16)	$Z_{total} = \frac{(Z_L \times Z_{TR})}{(Z_L + Z_{TR})}$
	$Z_{total} = \frac{((4 + j20) \Omega \times (4 + j20) \times 10^{10} \Omega)}{((4 + j20) \Omega + (4 + j20) \times 10^{10} \Omega)}$
	$Z_{total} = 4 + j20 \Omega$
Total system impedance.	
Eq. (17)	$Z_{sys} = Z_S + Z_{total} + Z_R$
	$Z_{sys} = (2 + j10) \Omega + (4 + j20) \Omega + (4 + j20) \Omega$
	$Z_{sys} = 10 + j50 \Omega$
Total system current from sending-end source.	
Eq. (18)	$I_{sys} = \frac{E_S - E_R}{Z_{sys}}$
	$I_{sys} = \frac{92,953.7 \angle 120^\circ V - 132,791 \angle 0^\circ V}{(10 + j50) \Omega}$
	$I_{sys} = 3,854 \angle 77^\circ A$
The current, as measured by the relay on $Z_L$ (Figure 3), is only the current flowing through that line as determined by using the current divider equation.	
Eq. (19)	$I_L = I_{sys} \times \frac{Z_{TR}}{Z_L + Z_{TR}}$
	$I_L = 3,854 \angle 77^\circ A \times \frac{(4 + j20) \times 10^{10} \Omega}{(4 + j20) \Omega + (4 + j20) \times 10^{10} \Omega}$
	$I_L = 3,854 \angle 77^\circ A$
The voltage, as measured by the relay on $Z_L$ (Figure 3), is the voltage drop from the sending-end source through the sending-end source impedance.	
Eq. (20)	$V_S = E_S - (Z_S \times I_{sys})$
	$V_S = 92,953 \angle 120^\circ V - [(2 + j10) \Omega \times 3,854 \angle 77^\circ A]$
	$V_S = 65,271 \angle 99^\circ V$
The impedance seen by the relay on $Z_L$ .	
Eq. (21)	$Z_{L-Relay} = \frac{V_S}{I_L}$

Table 3: Example Calculation (Lens Point 2)	
	$Z_{L-Relay} = \frac{65,271 \angle 99^\circ V}{3,854 \angle 77^\circ A}$
	$Z_{L-Relay} = 15.676 + j6.41 \Omega$

Table 4: Example Calculation (Lens Point 3)	
This example is for calculating the impedance third point of the lens characteristic. Unequal source voltages are used for the 230 kV (base) line with the receiving-end voltage ( $E_R$ ) at 70% of the sending-end voltage ( $E_S$ ) and the sending-end voltage leading the receiving-end voltage by 120 degrees. See Figures 3 and 4.	
Eq. (22)	$E_S = \frac{V_{LL} \angle 120^\circ}{\sqrt{3}}$
	$E_S = \frac{230,000 \angle 120^\circ V}{\sqrt{3}}$
	$E_S = 132,791 \angle 120^\circ V$
Eq. (23)	$E_R = \frac{V_{LL} \angle 0^\circ}{\sqrt{3}} \times 70\%$
	$E_R = \frac{230,000 \angle 0^\circ V}{\sqrt{3}} \times 0.70$
	$E_R = 92,953.7 \angle 0^\circ V$
Positive sequence impedance data (with transfer impedance $Z_{TR}$ set to a large value).	
Given:	$Z_S = 2 + j10 \Omega$ $Z_L = 4 + j20 \Omega$ $Z_R = 4 + j20 \Omega$
Given:	$Z_{TR} = Z_L \times 10^{10} \Omega$
Total impedance between the generators.	
Eq. (24)	$Z_{total} = \frac{(Z_L \times Z_{TR})}{(Z_L + Z_{TR})}$
	$Z_{total} = \frac{((4 + j20) \Omega \times (4 + j20) \times 10^{10} \Omega)}{((4 + j20) \Omega + (4 + j20) \times 10^{10} \Omega)}$
	$Z_{total} = 4 + j20 \Omega$
Total system impedance.	
Eq. (25)	$Z_{sys} = Z_S + Z_{total} + Z_R$
	$Z_{sys} = (2 + j10) \Omega + (4 + j20) \Omega + (4 + j20) \Omega$
	$Z_{sys} = 10 + j50 \Omega$

Table 4: Example Calculation (Lens Point 3)	
Total system current from sending-end source.	
Eq. (26)	$I_{sys} = \frac{E_S - E_R}{Z_{sys}}$
	$I_{sys} = \frac{132,791 \angle 120^\circ V - 92,953.7 \angle 0^\circ V}{(10 + j50) \Omega}$
	$I_{sys} = 3,854 \angle 65.5^\circ A$
The current, as measured by the relay on $Z_L$ (Figure 3), is only the current flowing through that line as determined by using the current divider equation.	
Eq. (27)	$I_L = I_{sys} \times \frac{Z_{TR}}{Z_L + Z_{TR}}$
	$I_L = 3,854 \angle 65.5^\circ A \times \frac{(4 + j20) \times 10^{10} \Omega}{(4 + j20) \Omega + (4 + j20) \times 10^{10} \Omega}$
	$I_L = 3,854 \angle 65.5^\circ A$
The voltage, as measured by the relay on $Z_L$ (Figure 3), is the voltage drop from the sending-end source through the sending-end source impedance.	
Eq. (28)	$V_S = E_S - (Z_S \times I_L)$
	$V_S = 132,791 \angle 120^\circ V - [(2 + j10) \Omega \times 3,854 \angle 65.5^\circ A]$
	$V_S = 98,265 \angle 110.6^\circ V$
The impedance seen by the relay on $Z_L$ .	
Eq. (29)	$Z_{L-Relay} = \frac{V_S}{I_L}$
	$Z_{L-Relay} = \frac{98,265 \angle 110.6^\circ V}{3,854 \angle 65.5^\circ A}$
	$Z_{L-Relay} = 18.005 + j18.054 \Omega$

Table 5: Example Calculation (Lens Point 4)	
This example is for calculating the impedance fourth point of the lens characteristic. Equal source voltages are used for the 230 kV (base) line with the sending-end voltage ( $E_S$ ) leading the receiving-end voltage ( $E_R$ ) by 240 degrees. See Figures 3 and 4.	
Eq. (30)	$E_S = \frac{V_{LL} \angle 240^\circ}{\sqrt{3}}$
	$E_S = \frac{230,000 \angle 240^\circ V}{\sqrt{3}}$

Table 5: Example Calculation (Lens Point 4)			
	$E_S = 132,791 \angle 240^\circ V$		
Eq. (31)	$E_R = \frac{V_{LL} \angle 0^\circ}{\sqrt{3}}$		
	$E_R = \frac{230,000 \angle 0^\circ V}{\sqrt{3}}$		
	$E_R = 132,791 \angle 0^\circ V$		
Positive sequence impedance data (with transfer impedance $Z_{TR}$ set to a large value).			
Given:	$Z_S = 2 + j10 \Omega$	$Z_L = 4 + j20 \Omega$	$Z_R = 4 + j20 \Omega$
Given:	$Z_{TR} = Z_L \times 10^{10} \Omega$		
Total impedance between the generators.			
Eq. (32)	$Z_{total} = \frac{(Z_L \times Z_{TR})}{(Z_L + Z_{TR})}$		
	$Z_{total} = \frac{((4 + j20) \Omega \times (4 + j20) \times 10^{10} \Omega)}{((4 + j20) \Omega + (4 + j20) \times 10^{10} \Omega)}$		
	$Z_{total} = 4 + j20 \Omega$		
Total system impedance.			
Eq. (33)	$Z_{sys} = Z_S + Z_{total} + Z_R$		
	$Z_{sys} = (2 + j10) \Omega + (4 + j20) \Omega + (4 + j20) \Omega$		
	$Z_{sys} = 10 + j50 \Omega$		
Total system current from sending-end source.			
Eq. (34)	$I_{sys} = \frac{E_S - E_R}{Z_{sys}}$		
	$I_{sys} = \frac{132,791 \angle 240^\circ V - 132,791 \angle 0^\circ V}{(10 + j50) \Omega}$		
	$I_{sys} = 4,511 \angle 131.3^\circ A$		
The current, as measured by the relay on $Z_L$ (Figure 3), is only the current flowing through that line as determined by using the current divider equation.			
Eq. (35)	$I_L = I_{sys} \times \frac{Z_{TR}}{Z_L + Z_{TR}}$		
	$I_L = 4,511 \angle 131.1^\circ A \times \frac{(4 + j20) \times 10^{10} \Omega}{(4 + j20) \Omega + (4 + j20) \times 10^{10} \Omega}$		
	$I_L = 4,511 \angle 131.1^\circ A$		

**Table 5: Example Calculation (Lens Point 4)**

The voltage, as measured by the relay on $Z_L$ (Figure 3), is the voltage drop from the sending-end source through the sending-end source impedance.	
Eq. (36)	$V_S = E_S - (Z_S \times I_L)$
	$V_S = 132,791 \angle 240^\circ V - [(2 + j10) \Omega \times 4,511 \angle 131.1^\circ A]$
	$V_S = 95,756 \angle -106.1^\circ V$
The impedance seen by the relay on $Z_L$ .	
Eq. (37)	$Z_{L-Relay} = \frac{V_S}{I_L}$
	$Z_{L-Relay} = \frac{95,756 \angle -106.1^\circ V}{4,511 \angle 131.1^\circ A}$
	$Z_{L-Relay} = -11.434 + j17.887 \Omega$

**Table 6: Example Calculation (Lens Point 5)**

This example is for calculating the impedance fifth point of the lens characteristic. Unequal source voltages are used for the 230 kV (base) line with the sending-end voltage ( $E_S$ ) at 70% of the receiving-end voltage ( $E_R$ ) and leading the receiving-end voltage by 240 degrees. See Figures 3 and 4.	
Eq. (38)	$E_S = \frac{V_{LL} \angle 240^\circ}{\sqrt{3}} \times 70\%$
	$E_S = \frac{230,000 \angle 240^\circ V}{\sqrt{3}} \times 0.70$
	$E_S = 92,953.7 \angle 240^\circ V$
Eq. (39)	$E_R = \frac{V_{LL} \angle 0^\circ}{\sqrt{3}}$
	$E_R = \frac{230,000 \angle 0^\circ V}{\sqrt{3}}$
	$E_R = 132,791 \angle 0^\circ V$
Positive sequence impedance data (with transfer impedance $Z_{TR}$ set to a large value).	
Given:	$Z_S = 2 + j10 \Omega$ $Z_L = 4 + j20 \Omega$ $Z_R = 4 + j20 \Omega$
Given:	$Z_{TR} = Z_L \times 10^{10} \Omega$
Total impedance between the generators.	
Eq. (40)	$Z_{total} = \frac{(Z_L \times Z_{TR})}{(Z_L + Z_{TR})}$

Table 6: Example Calculation (Lens Point 5)	
	$Z_{total} = \frac{((4 + j20) \Omega \times (4 + j20) \times 10^{10} \Omega)}{((4 + j20) \Omega + (4 + j20) \times 10^{10} \Omega)}$
	$Z_{total} = 4 + j20 \Omega$
Total system impedance.	
Eq. (41)	$Z_{sys} = Z_S + Z_{total} + Z_R$
	$Z_{sys} = (2 + j10 \Omega) + (4 + j20 \Omega) + (4 + j20 \Omega)$
	$Z_{sys} = 10 + j50 \Omega$
Total system current from sending-end source.	
Eq. (42)	$I_{sys} = \frac{E_S - E_R}{Z_{sys}}$
	$I_{sys} = \frac{92,953.7 \angle 240^\circ V - 132,791 \angle 0^\circ V}{10 + j50 \Omega}$
	$I_{sys} = 3,854 \angle 125.5^\circ A$
The current, as measured by the relay on $Z_L$ (Figure 3), is only the current flowing through that line as determined by using the current divider equation.	
Eq. (43)	$I_L = I_{sys} \times \frac{Z_{TR}}{Z_L + Z_{TR}}$
	$I_L = 3,854 \angle 125.5^\circ A \times \frac{(4 + j20) \times 10^{10} \Omega}{(4 + j20) \Omega + (4 + j20) \times 10^{10} \Omega}$
	$I_L = 3,854 \angle 125.5^\circ A$
The voltage, as measured by the relay on $Z_L$ (Figure 3), is the voltage drop from the sending-end source through the sending-end source impedance.	
Eq. (44)	$V_S = E_S - (Z_S \times I_L)$
	$V_S = 92,953.7 \angle 240^\circ V - [(2 + j10) \Omega \times 3,854 \angle 125.5^\circ A]$
	$V_S = 65,270.5 \angle -99.4^\circ V$
The impedance seen by the relay on $Z_L$ .	
Eq. (45)	$Z_{L-Relay} = \frac{V_S}{I_L}$
	$Z_{L-Relay} = \frac{65,270.5 \angle -99.4^\circ V}{3,854 \angle 125.5^\circ A}$
	$Z_{L-Relay} = -12.005 + j11.946 \Omega$

**Table 7: Example Calculation (Lens Point 6)**

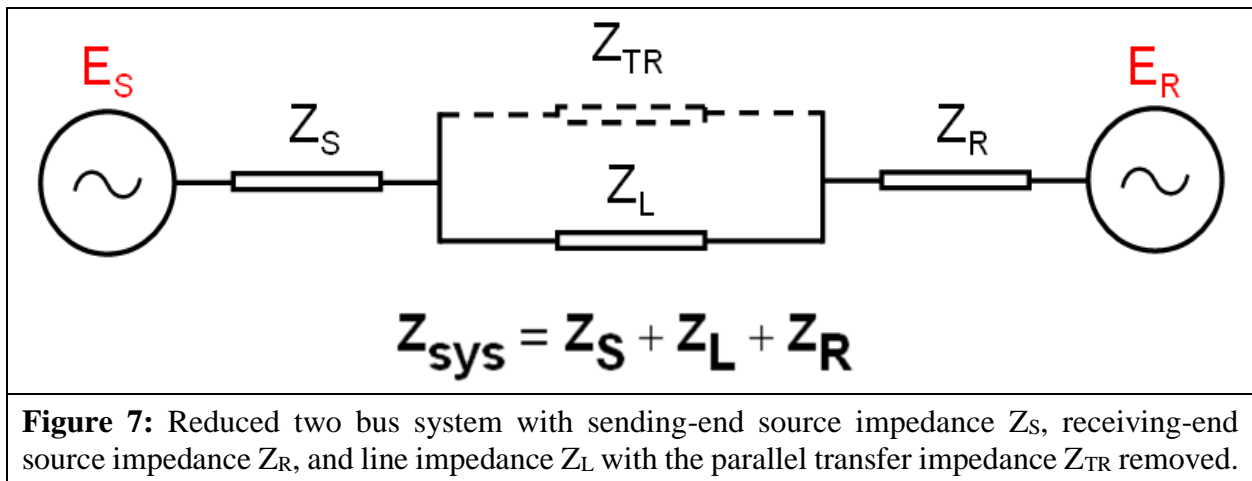
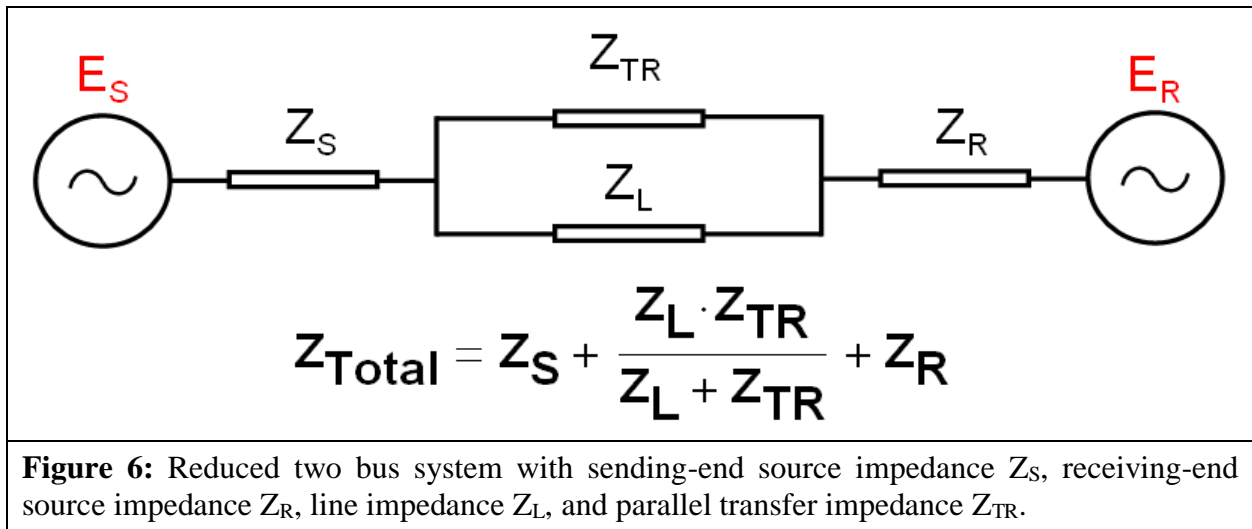
This example is for calculating the impedance sixth point of the lens characteristic. Unequal source voltages are used for the 230 kV (base) line with the receiving-end voltage ( $E_R$ ) at 70% of the sending-end voltage ( $E_S$ ) and the sending-end voltage leading the receiving-end voltage by 240 degrees. See Figures 3 and 4.

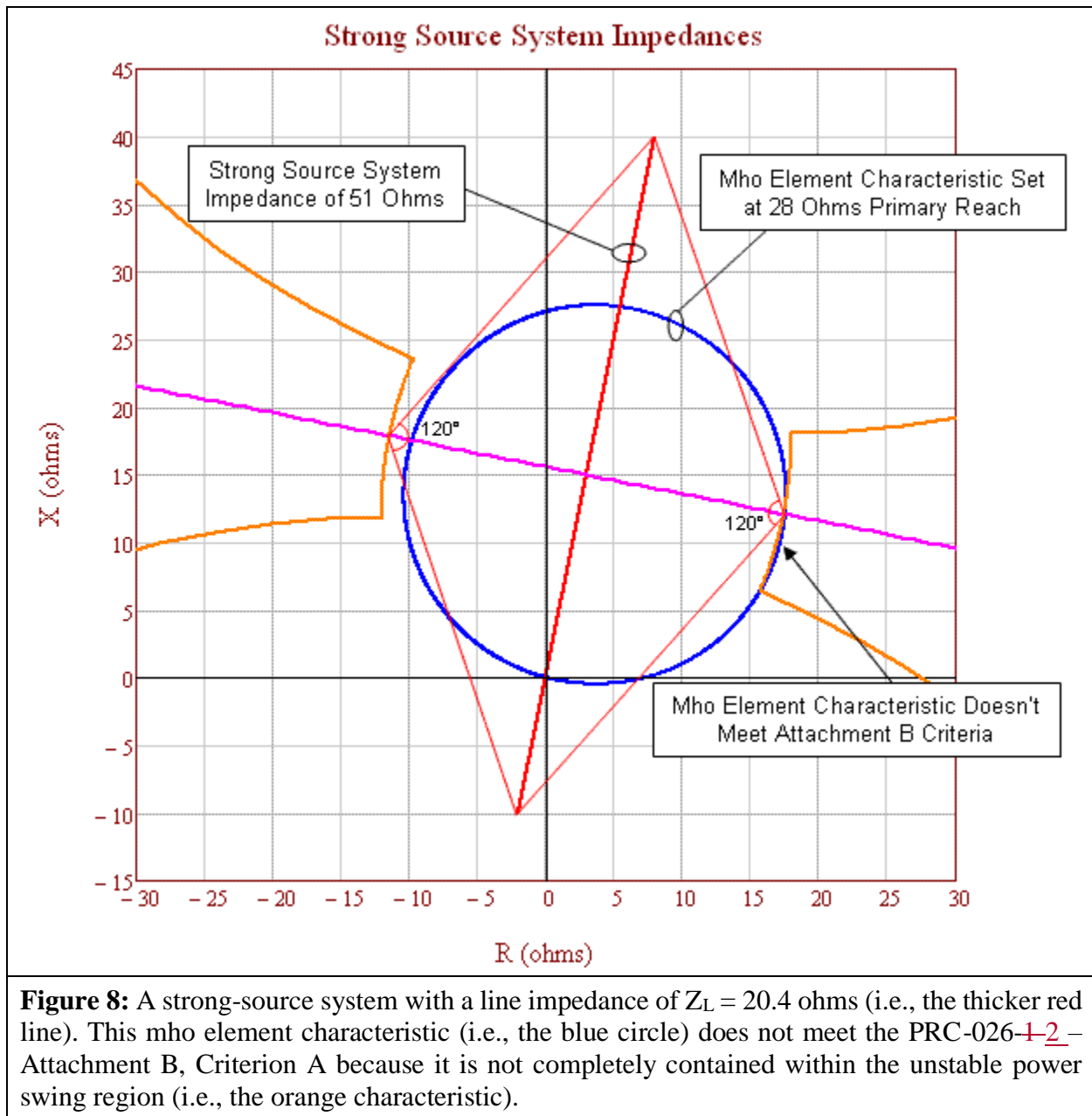
Eq. (46)	$E_S = \frac{V_{LL} \angle 240^\circ}{\sqrt{3}}$		
	$E_S = \frac{230,000 \angle 240^\circ V}{\sqrt{3}}$		
	$E_S = 132,791 \angle 240^\circ V$		
Eq. (47)	$E_R = \frac{V_{LL} \angle 0^\circ}{\sqrt{3}} \times 70\%$		
	$E_R = \frac{230,000 \angle 0^\circ V}{\sqrt{3}} \times 0.70$		
	$E_R = 92,953.7 \angle 0^\circ V$		
Positive sequence impedance data (with transfer impedance $Z_{TR}$ set to a large value).			
Given:	$Z_S = 2 + j10 \Omega$	$Z_L = 4 + j20 \Omega$	$Z_R = 4 + j20 \Omega$
Given:	$Z_{TR} = Z_L \times 10^{10} \Omega$		
Total impedance between the generators.			
Eq. (48)	$Z_{total} = \frac{(Z_L \times Z_{TR})}{(Z_L + Z_{TR})}$		
	$Z_{total} = \frac{((4 + j20) \Omega \times (4 + j20) \times 10^{10} \Omega)}{((4 + j20) \Omega + (4 + j20) \times 10^{10} \Omega)}$		
	$Z_{total} = 4 + j20 \Omega$		
Total system impedance.			
Eq. (49)	$Z_{sys} = Z_S + Z_{total} + Z_R$		
	$Z_{sys} = (2 + j10) \Omega + (4 + j20) \Omega + (4 + j20) \Omega$		
	$Z_{sys} = 10 + j50 \Omega$		
Total system current from sending-end source.			
Eq. (50)	$I_{sys} = \frac{E_S - E_R}{Z_{sys}}$		
	$I_{sys} = \frac{132,791 \angle 240^\circ V - 92,953.7 \angle 0^\circ V}{10 + j50 \Omega}$		
	$I_{sys} = 3,854 \angle 137.1^\circ A$		



**Table 7: Example Calculation (Lens Point 6)**

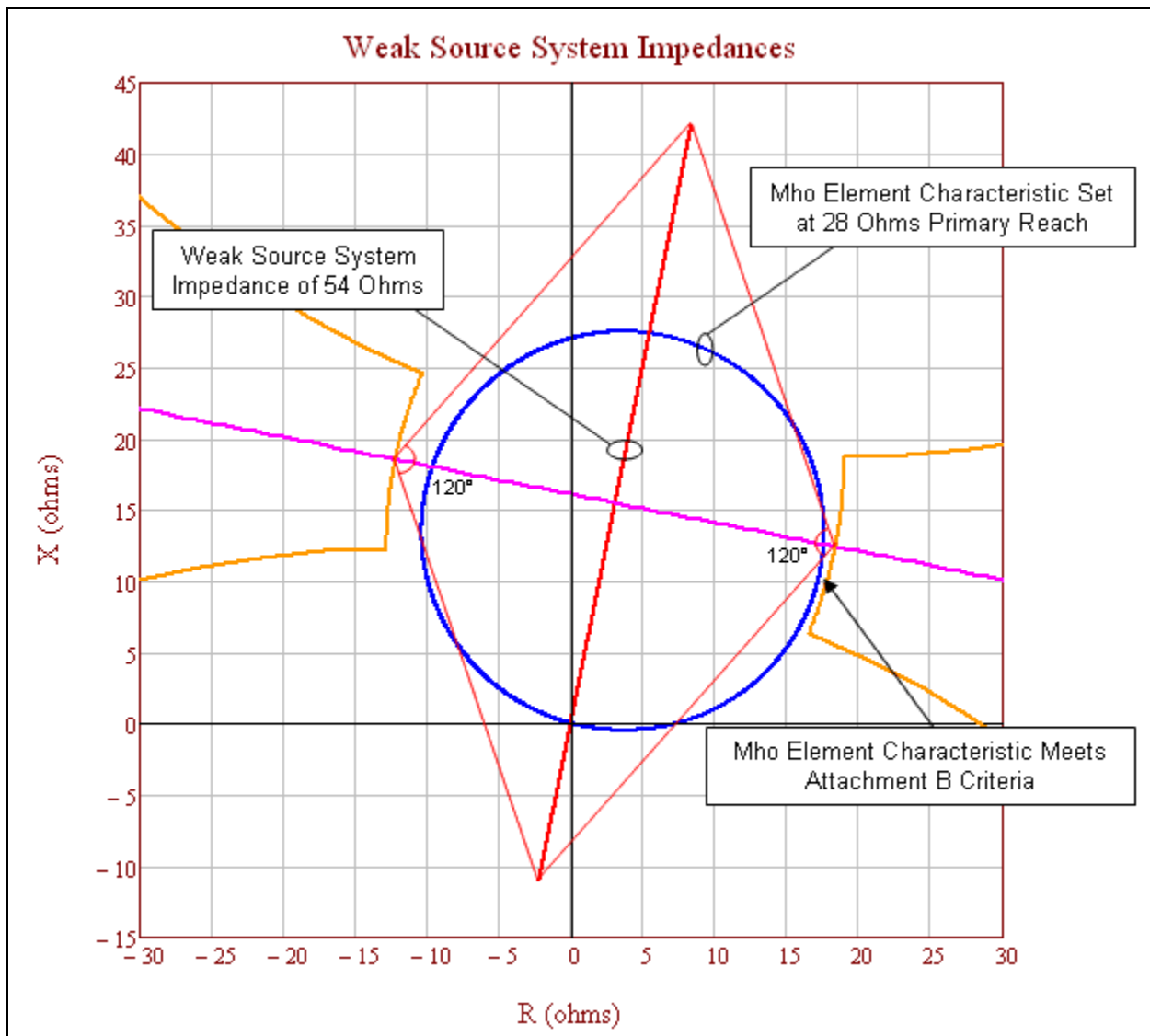
The current, as measured by the relay on $Z_L$ (Figure 3), is only the current flowing through that line as determined by using the current divider equation.	
Eq. (51)	$I_L = I_{sys} \times \frac{Z_{TR}}{Z_L + Z_{TR}}$
	$I_L = 3,854 \angle 137.1^\circ A \times \frac{(4 + j20) \times 10^{10} \Omega}{(4 + j20) \Omega + (4 + j20) \times 10^{10} \Omega}$
	$I_L = 3,854 \angle 137.1^\circ A$
The voltage, as measured by the relay on $Z_L$ (Figure 3), is the voltage drop from the sending-end source through the sending-end source impedance.	
Eq. (52)	$V_S = E_S - (Z_S \times I_L)$
	$V_S = 132,791 \angle 240^\circ V - [(2 + j10) \Omega \times 3,854 \angle 137.1^\circ A]$
	$V_S = 98,265 \angle -110.6^\circ V$
The impedance seen by the relay on $Z_L$ .	
Eq. (53)	$Z_{L-Relay} = \frac{V_S}{I_L}$
	$Z_{L-Relay} = \frac{98,265 \angle -110.6^\circ V}{3,854 \angle 137.1^\circ A}$
	$Z_{L-Relay} = -9.676 + j23.59 \Omega$





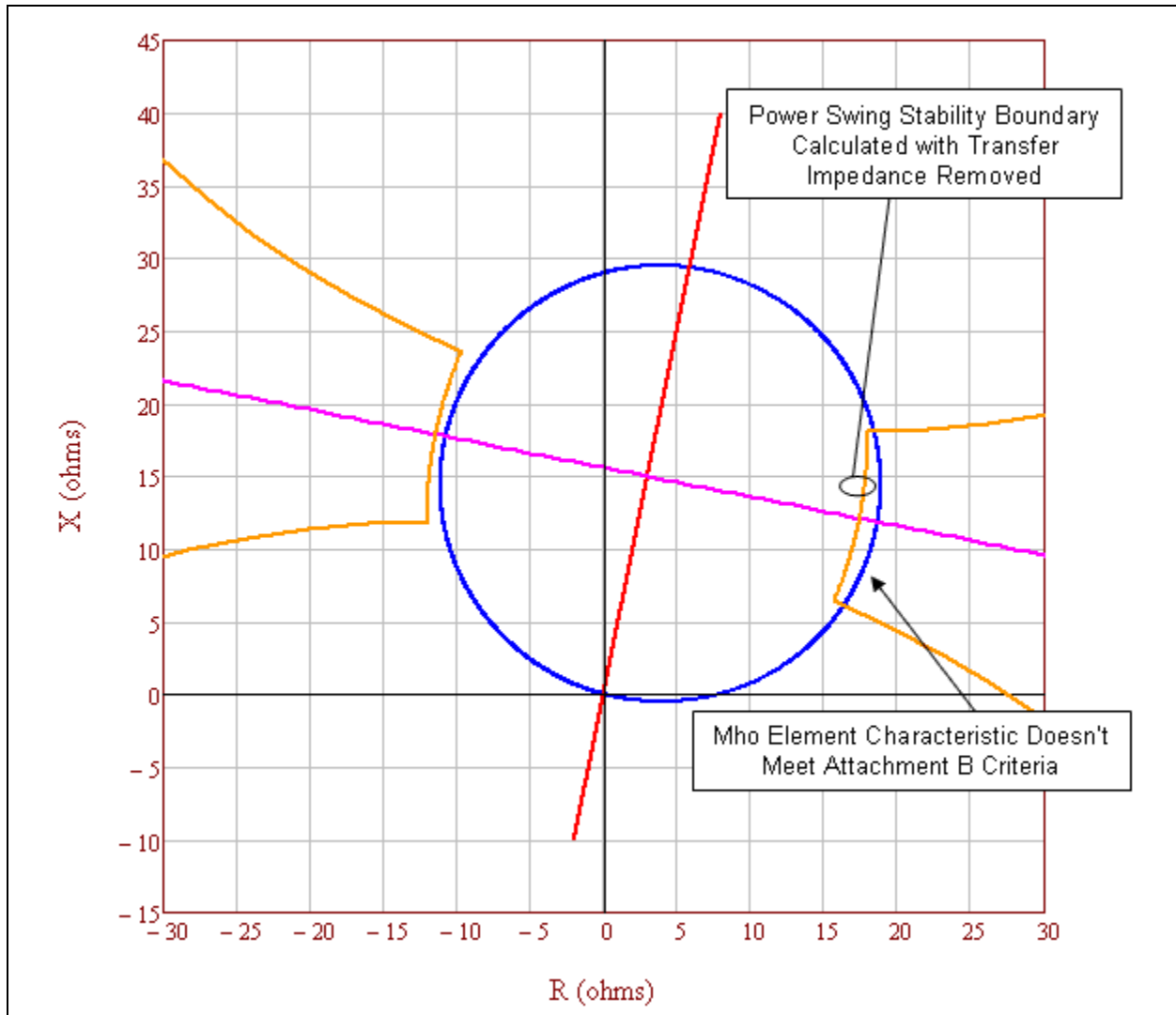
**Figure 8:** A strong-source system with a line impedance of  $Z_L = 20.4$  ohms (i.e., the thicker red line). This mho element characteristic (i.e., the blue circle) does not meet the PRC-026-1-2 – Attachment B, Criterion A because it is not completely contained within the unstable power swing region (i.e., the orange characteristic).

Figure 8 above represents a heavily-loaded system with all generation in service and all transmission BES Elements in their normal operating state. The mho element characteristic (set at 137% of  $Z_L$ ) extends into the unstable power swing region (i.e., the orange characteristic). Using the strongest source system is more conservative because it shrinks the unstable power swing region, bringing it closer to the mho element characteristic. This figure also graphically represents the effect of a system strengthening over time and this is the reason for re-evaluation if the relay has not been evaluated in the last five calendar years. Figure 9 below depicts a relay that meets the PRC-026-1-2 – Attachment B, Criterion A. Figure 8 depicts the same relay with the same setting five years later, where each source has strengthened by about 10% and now the same mho element characteristic does not meet Criterion A.



**Figure 9:** A weak-source system with a line impedance of  $Z_L = 20.4$  ohms (i.e., the thicker red line). This mho element characteristic (i.e., the blue circle) meets the PRC-026-1 Attachment B, Criterion A because it is completely contained within the unstable power swing region (i.e., the orange characteristic).

Figure 9 above represents a lightly-loaded system, using a minimum generation profile. The mho element characteristic (set at 137% of  $Z_L$ ) does not extend into the unstable power swing region (i.e., the orange characteristic). Using a weaker source system expands the unstable power swing region away from the mho element characteristic.

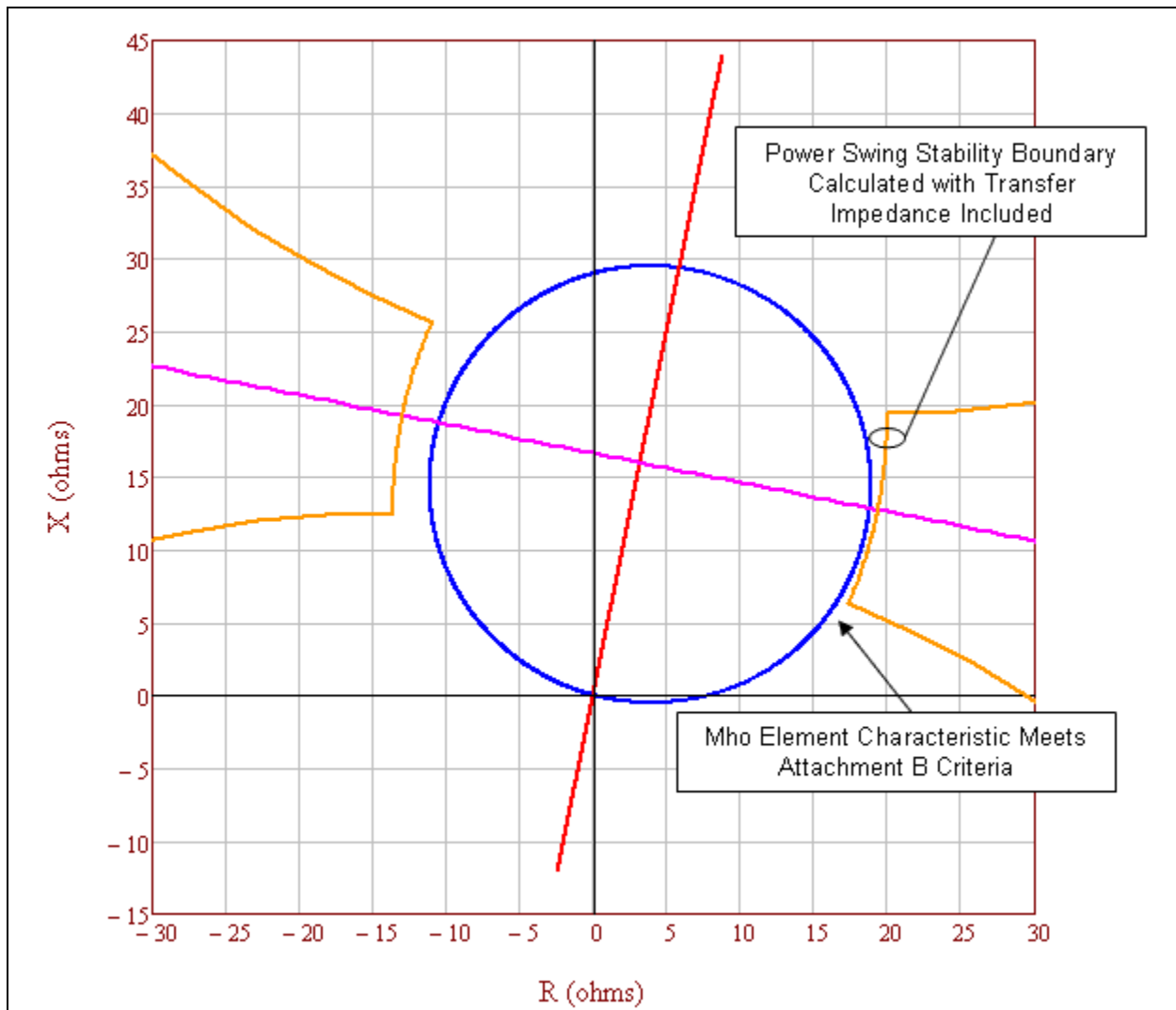


**Figure 10:** This is an example of an unstable power swing region (i.e., the orange characteristic) with the parallel transfer impedance removed. This relay mho element characteristic (i.e., the blue circle) does not meet PRC-026-1 Attachment B, Criterion A because it is not completely contained within the unstable power swing region.

Table 8: Example Calculation (Parallel Transfer Impedance Removed)	
Calculations for the point at 120 degrees with equal source impedances. The total system current equals the line current. See Figure 10.	
Eq. (54)	$E_S = \frac{V_{LL} \angle 120^\circ}{\sqrt{3}}$
	$E_S = \frac{230,000 \angle 120^\circ V}{\sqrt{3}}$
	$E_S = 132,791 \angle 120^\circ V$

Table 8: Example Calculation (Parallel Transfer Impedance Removed)			
Eq. (55)	$E_R = \frac{V_{LL} \angle 0^\circ}{\sqrt{3}}$		
	$E_R = \frac{230,000 \angle 0^\circ V}{\sqrt{3}}$		
	$E_R = 132,791 \angle 0^\circ V$		
Given impedance data.			
Given:	$Z_S = 2 + j10 \Omega$	$Z_L = 4 + j20 \Omega$	$Z_R = 4 + j20 \Omega$
Given:	$Z_{TR} = Z_L \times 10^{10} \Omega$		
Total impedance between the generators.			
Eq. (56)	$Z_{total} = \frac{(Z_L \times Z_{TR})}{(Z_L + Z_{TR})}$		
	$Z_{total} = \frac{(4 + j20) \Omega \times (4 + j20) \times 10^{10} \Omega}{(4 + j20) \Omega + (4 + j20) \times 10^{10} \Omega}$		
	$Z_{total} = 4 + j20 \Omega$		
Total system impedance.			
Eq. (57)	$Z_{sys} = Z_S + Z_{total} + Z_R$		
	$Z_{sys} = (2 + j10) \Omega + (4 + j20) \Omega + (4 + j20) \Omega$		
	$Z_{sys} = 10 + j50 \Omega$		
Total system current from sending-end source.			
Eq. (58)	$I_{sys} = \frac{E_S - E_R}{Z_{sys}}$		
	$I_{sys} = \frac{132,791 \angle 120^\circ V - 132,791 \angle 0^\circ V}{10 + j50 \Omega}$		
	$I_{sys} = 4,511 \angle 71.3^\circ A$		
The current, as measured by the relay on $Z_L$ (Figure 3), is only the current flowing through that line as determined by using the current divider equation.			
Eq. (59)	$I_L = I_{sys} \times \frac{Z_{TR}}{Z_L + Z_{TR}}$		
	$I_L = 4,511 \angle 71.3^\circ A \times \frac{(4 + j20) \times 10^{10} \Omega}{(4 + j20) \Omega + (4 + j20) \times 10^{10} \Omega}$		
	$I_L = 4,511 \angle 71.3^\circ A$		

Table 8: Example Calculation (Parallel Transfer Impedance Removed)	
The voltage, as measured by the relay on $Z_L$ (Figure 3), is the voltage drop from the sending-end source through the sending-end source impedance.	
Eq. (60)	$V_S = E_S - (Z_S \times I_{sys})$
	$V_S = 132,791 \angle 120^\circ V - [(2 + j10 \Omega) \times 4,511 \angle 71.3^\circ A]$
	$V_S = 95,757 \angle 106.1^\circ V$
The impedance seen by the relay on $Z_L$ .	
Eq. (61)	$Z_{L-Relay} = \frac{V_S}{I_L}$
	$Z_{L-Relay} = \frac{95,757 \angle 106.1^\circ V}{4,511 \angle 71.3^\circ A}$
	$Z_{L-Relay} = 17.434 + j12.113 \Omega$



**Figure 11:** This is an example of an unstable power swing region (i.e., the orange characteristic) with the parallel transfer impedance included causing the mho element characteristic (i.e., the blue circle) to appear to meet the PRC-026-1.2 – Attachment B, Criterion A because it is completely contained within the unstable power swing region. Including the parallel transfer impedance in the calculation is not allowed by the PRC-026-1.2 – Attachment B, Criterion A.

In Figure 11 above, the parallel transfer impedance is 5 times the line impedance. The unstable power swing region has expanded out beyond the mho element characteristic due to the infeed effect from the parallel current through the parallel transfer impedance, thus allowing the mho element characteristic to appear to meet the PRC-026-1.2 – Attachment B, Criterion A. Including the parallel transfer impedance in the calculation is not allowed by the PRC-026-1.2 – Attachment B, Criterion A.



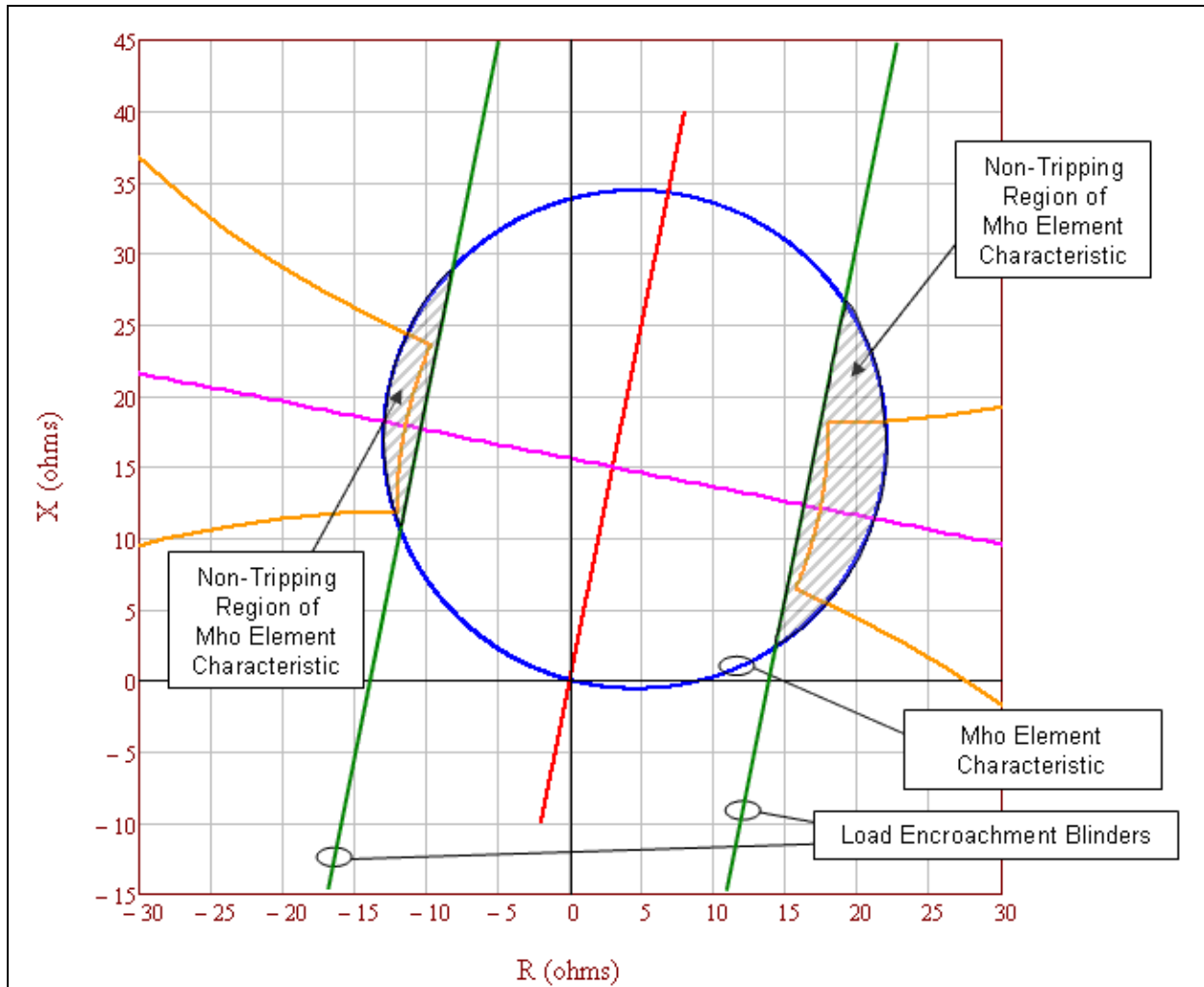
Table 9: Example Calculation (Parallel Transfer Impedance Included)			
Calculations for the point at 120 degrees with equal source impedances. The total system current does not equal the line current. See Figure 11.			
Eq. (62)	$E_S = \frac{V_{LL} \angle 120^\circ}{\sqrt{3}}$		
	$E_S = \frac{230,000 \angle 120^\circ V}{\sqrt{3}}$		
	$E_S = 132,791 \angle 120^\circ V$		
Eq. (63)	$E_R = \frac{V_{LL} \angle 0^\circ}{\sqrt{3}}$		
	$E_R = \frac{230,000 \angle 0^\circ V}{\sqrt{3}}$		
	$E_R = 132,791 \angle 0^\circ V$		
Given impedance data.			
Given:	$Z_S = 2 + j10 \Omega$	$Z_L = 4 + j20 \Omega$	$Z_R = 4 + j20 \Omega$
Given:	$Z_{TR} = Z_L \times 5$		
	$Z_{TR} = (4 + j20) \Omega \times 5$		
	$Z_{TR} = 20 + j100 \Omega$		
Total impedance between the generators.			
Eq. (64)	$Z_{total} = \frac{(Z_L \times Z_{TR})}{(Z_L + Z_{TR})}$		
	$Z_{total} = \frac{(4 + j20) \Omega \times (20 + j100) \Omega}{(4 + j20) \Omega + (20 + j100) \Omega}$		
	$Z_{total} = 3.333 + j16.667 \Omega$		
Total system impedance.			
Eq. (65)	$Z_{sys} = Z_S + Z_{total} + Z_R$		
	$Z_{sys} = (2 + j10) \Omega + (3.333 + j16.667) \Omega + (4 + j20) \Omega$		
	$Z_{sys} = 9.333 + j46.667 \Omega$		
Total system current from sending-end source.			
Eq. (66)	$I_{sys} = \frac{E_S - E_R}{Z_{sys}}$		
	$I_{sys} = \frac{132,791 \angle 120^\circ V - 132,791 \angle 0^\circ V}{9.333 + j46.667 \Omega}$		

Table 9: Example Calculation (Parallel Transfer Impedance Included)	
	$I_{sys} = 4,833 \angle 71.3^\circ A$
The current, as measured by the relay on $Z_L$ (Figure 3), is only the current flowing through that line as determined by using the current divider equation.	
Eq. (67)	$I_L = I_{sys} \times \frac{Z_{TR}}{Z_L + Z_{TR}}$
	$I_L = 4,833 \angle 71.3^\circ A \times \frac{(20 + j100) \Omega}{(4 + j20) \Omega + (20 + j100) \Omega}$
	$I_L = 4,027.4 \angle 71.3^\circ A$
The voltage, as measured by the relay on $Z_L$ (Figure 3), is the voltage drop from the sending-end source through the sending-end source impedance.	
Eq. (68)	$V_S = E_S - (Z_S \times I_{sys})$
	$V_S = 132,791 \angle 120^\circ V - [(2 + j10 \Omega) \times 4,833 \angle 71.3^\circ A]$
	$V_S = 93,417 \angle 104.7^\circ V$
The impedance seen by the relay on $Z_L$ .	
Eq. (69)	$Z_{L-Relay} = \frac{V_S}{I_L}$
	$Z_{L-Relay} = \frac{93,417 \angle 104.7^\circ V}{4,027 \angle 71.3^\circ A}$
	$Z_{L-Relay} = 19.366 + j12.767 \Omega$

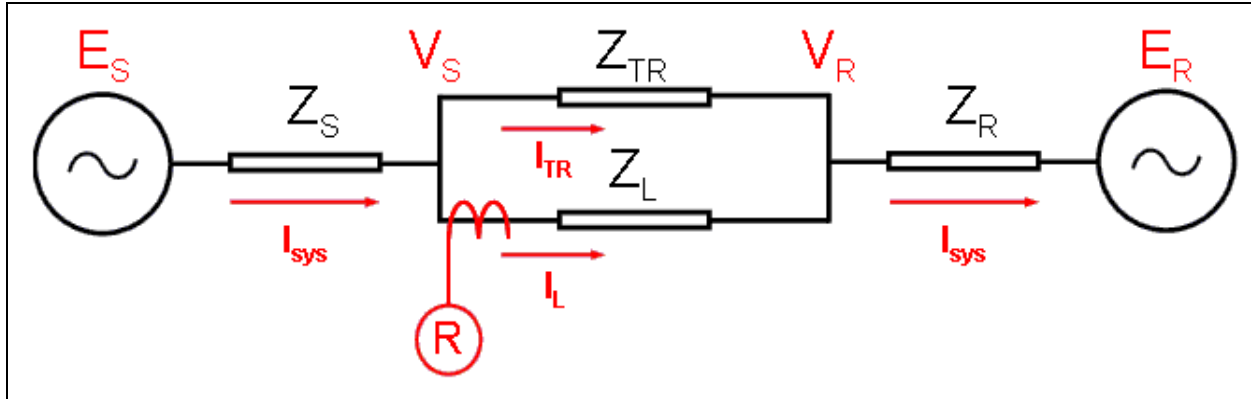
**Table 10: Percent Increase of a Lens Due To Parallel Transfer Impedance.**

The following demonstrates the percent size increase of the lens characteristic for  $Z_{TR}$  in multiples of  $Z_L$  with the parallel transfer impedance included.

$Z_{TR}$ in multiples of $Z_L$	Percent increase of lens with equal EMF sources (Infinite source as reference)
Infinite	N/A
1000	0.05%
100	0.46%
10	4.63%
5	9.27%
2	23.26%
1	46.76%
0.5	94.14%
0.25	189.56%



**Figure 12:** The tripping portion of the mho element characteristic (i.e., the blue circle) not blocked by load encroachment (i.e., the parallel green lines) is completely contained within the unstable power swing region (i.e., the orange characteristic). Therefore, the mho element characteristic meets the PRC-026-1-2 Attachment B, Criterion A.



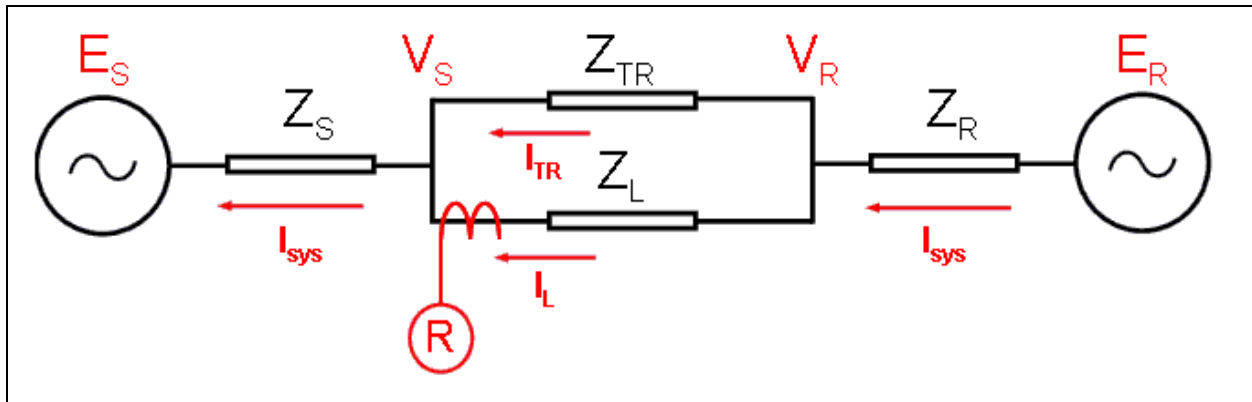
**Figure 13:** The infeed diagram shows the impedance in front of the relay R with the parallel transfer impedance included. As the parallel transfer impedance approaches infinity, the impedances seen by the relay R in the forward direction becomes  $Z_L + Z_R$ .

**Table 11: Calculations (System Apparent Impedance in the forward direction)**

The following equations are provided for calculating the apparent impedance back to the  $E_R$  source voltage as seen by relay R. Infeed equations from  $V_S$  to source  $E_R$  where  $E_R = 0$ . See Figure 13.

Eq. (70)	$I_L = \frac{V_S - V_R}{Z_L}$			
Eq. (71)	$I_{sys} = \frac{V_R - E_R}{Z_R}$			
Eq. (72)	$I_{sys} = I_L + I_{TR}$			
Eq. (73)	$I_{sys} = \frac{V_R}{Z_R}$	Since $E_R = 0$	Rearranged:	$V_R = I_{sys} \times Z_R$
Eq. (74)	$I_L = \frac{V_S - I_{sys} \times Z_R}{Z_L}$			
Eq. (75)	$I_L = \frac{V_S - [(I_L + I_{TR}) \times Z_R]}{Z_L}$			
Eq. (76)	$V_S = (I_L \times Z_L) + (I_L \times Z_R) + (I_{TR} \times Z_R)$			
Eq. (77)	$Z_{Relay} = \frac{V_S}{I_L} = Z_L + Z_R + \frac{I_{TR} \times Z_R}{I_L} = Z_L + Z_R \times \left(1 + \frac{I_{TR}}{I_L}\right)$			
Eq. (78)	$I_{TR} = I_{sys} \times \frac{Z_L}{Z_L + Z_{TR}}$			
Eq. (79)	$I_L = I_{sys} \times \frac{Z_{TR}}{Z_L + Z_{TR}}$			

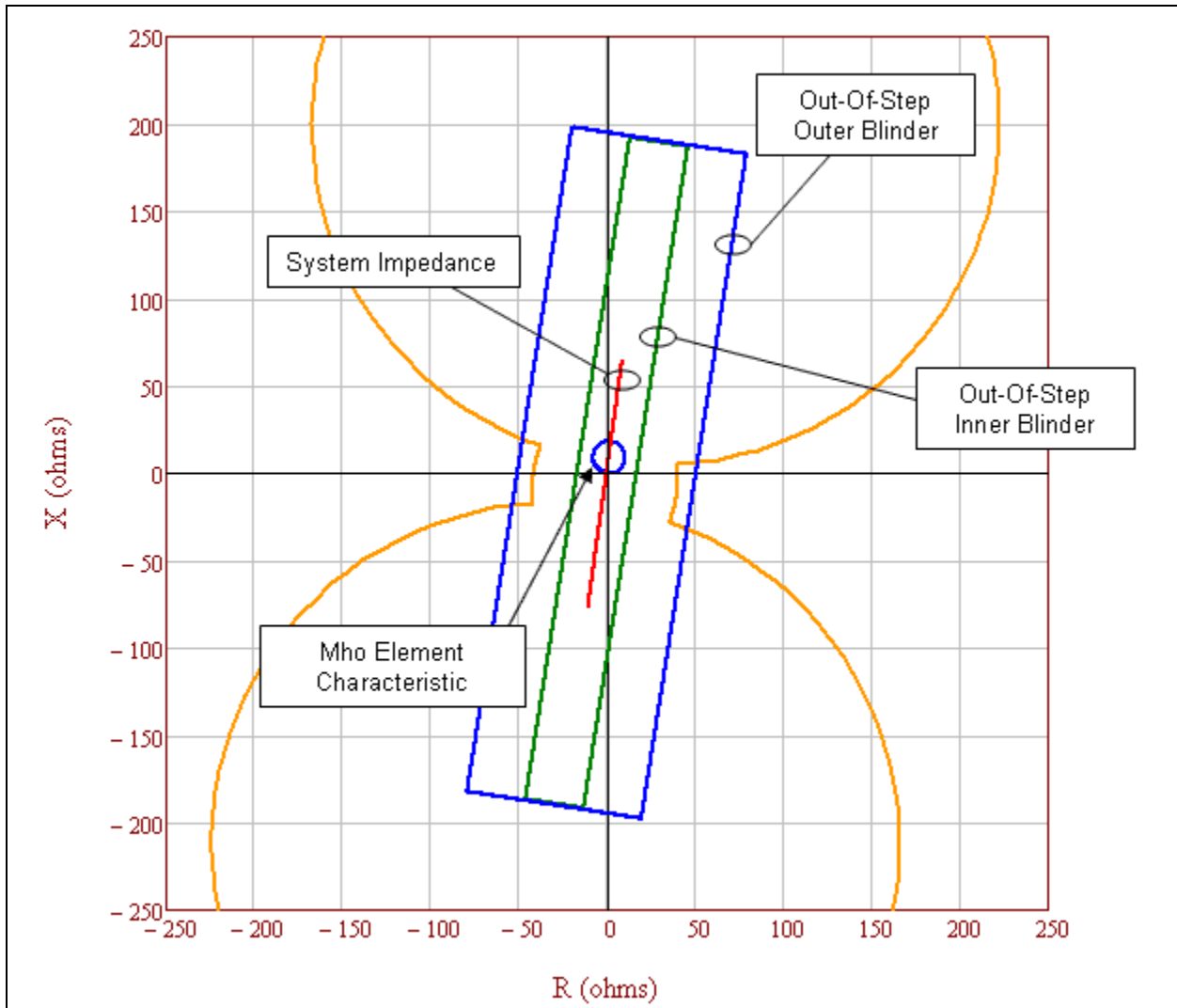
Table 11: Calculations (System Apparent Impedance in the forward direction)	
Eq. (80)	$\frac{I_{TR}}{I_L} = \frac{Z_L}{Z_{TR}}$
The infeed equations shows the impedance in front of the relay R (Figure 13) with the parallel transfer impedance included. As the parallel transfer impedance approaches infinity, the impedances seen by the relay R in the forward direction becomes $Z_L + Z_R$ .	
Eq. (81)	$Z_{Relay} = Z_L + Z_R \times \left(1 + \frac{Z_L}{Z_{TR}}\right)$



**Figure 14:** The infeed diagram shows the impedance behind relay R with the parallel transfer impedance included. As the parallel transfer impedance approaches infinity, the impedances seen by the relay R in the reverse direction becomes  $Z_S$ .

Table 12: Calculations (System Apparent Impedance in the Reverse Direction)				
The following equations are provided for calculating the apparent impedance back to the $E_S$ source voltage as seen by relay R. Infeed equations from $V_R$ back to source $E_S$ where $E_S = 0$ . See Figure 14.				
Eq. (82)	$I_L = \frac{V_R - V_S}{Z_L}$			
Eq. (83)	$I_{sys} = \frac{V_S - E_S}{Z_S}$			
Eq. (84)	$I_{sys} = I_L + I_{TR}$			
Eq. (85)	$I_{sys} = \frac{V_S}{Z_S}$	Since $E_S = 0$	Rearranged:	$V_S = I_{sys} \times Z_S$
Eq. (86)	$I_L = \frac{V_R - I_{sys} \times Z_S}{Z_L}$			

Table 12: Calculations (System Apparent Impedance in the Reverse Direction)		
Eq. (87)	$I_L = \frac{V_R - [(I_L + I_{TR}) \times Z_S]}{Z_L}$	
Eq. (88)	$V_R = (I_L \times Z_L) + (I_L \times Z_S) + (I_{TR} \times Z_{RS})$	
Eq. (89)	$Z_{Relay} = \frac{V_R}{I_L} = Z_L + Z_S + \frac{I_{TR} \times Z_S}{I_L} = Z_L + Z_S \times \left(1 + \frac{I_{TR}}{I_L}\right)$	
Eq. (90)	$I_{TR} = I_{sys} \times \frac{Z_L}{Z_L + Z_{TR}}$	
Eq. (91)	$I_L = I_{sys} \times \frac{Z_{TR}}{Z_L + Z_{TR}}$	
Eq. (92)	$\frac{I_{TR}}{I_L} = \frac{Z_L}{Z_{TR}}$	
The infeed equations shows the impedance behind relay R (Figure 14) with the parallel transfer impedance included. As the parallel transfer impedance approaches infinity, the impedances seen by the relay R in the reverse direction becomes $Z_S$ .		
Eq. (93)	$Z_{Relay} = Z_L + Z_S \times \left(1 + \frac{Z_L}{Z_{TR}}\right)$	As seen by relay R at the receiving-end of the line.
Eq. (94)	$Z_{Relay} = Z_S \times \left(1 + \frac{Z_L}{Z_{TR}}\right)$	Subtract $Z_L$ for relay R impedance as seen at sending-end of the line.



**Figure 15:** Out-of-step trip (OST) inner blinder (i.e., the parallel green lines) meets the PRC-026-1-2 – Attachment B, Criterion A because the inner OST blinder initiates tripping either On-The-Way-In or On-The-Way-Out. Since the inner blinder is completely contained within the unstable power swing region (i.e., the orange characteristic), it meets the PRC-026-1-2 – Attachment B, Criterion A.



**Table 13: Example Calculation (Voltage Ratios)**

These calculations are based on the loss-of-synchronism characteristics for the cases of  $N < 1$  and  $N > 1$  as found in the *Application of Out-of-Step Blocking and Tripping Relays*, GER-3180, p. 12, Figure 3.<sup>18</sup> The GE illustration shows the formulae used to calculate the radius and center of the circles that make up the ends of the portion of the lens.

Voltage ratio equations, source impedance equation with infeed formulae applied, and circle equations.

Given:	$E_S = 0.7$	$E_R = 1.0$
--------	-------------	-------------

Eq. (95)	$N = \frac{ E_S }{ E_R } = \frac{0.7}{1.0} = 0.7$
----------	---

The total system impedance as seen by the relay with infeed formulae applied.

Given:	$Z_S = 2 + j10 \Omega$	$Z_L = 4 + j20 \Omega$	$Z_R = 4 + j20 \Omega$
--------	------------------------	------------------------	------------------------

Given:	$Z_{TR} = Z_L \times 10^{10} \Omega$
--------	--------------------------------------

	$Z_{TR} = (4 + j20) \times 10^{10} \Omega$
--	--

Eq. (96)	$Z_{sys} = Z_S \times \left(1 + \frac{Z_L}{Z_{TR}}\right) + \left[Z_L + Z_R \times \left(1 + \frac{Z_L}{Z_{TR}}\right)\right]$
----------	--

	$Z_{sys} = 10 + j50 \Omega$
--	-----------------------------

The calculated coordinates of the lower loss-of-synchronism circle center.

Eq. (97)	$Z_{C1} = - \left[ Z_S \times \left(1 + \frac{Z_L}{Z_{TR}}\right) \right] - \left[ \frac{N^2 \times Z_{sys}}{1 - N^2} \right]$
----------	--

	$Z_{C1} = - \left[ (2 + j10) \Omega \times \left(1 + \frac{(4 + j20) \Omega}{(4 + j20) \times 10^{10} \Omega}\right) \right] - \left[ \frac{0.7^2 \times (10 + j50) \Omega}{1 - 0.7^2} \right]$
--	---

	$Z_{C1} = -11.608 - j58.039 \Omega$
--	-------------------------------------

The calculated radius of the lower loss-of-synchronism circle.

Eq. (98)	$r_a = \left  \frac{N \times Z_{sys}}{1 - N^2} \right $
----------	---

	$r_a = \left  \frac{0.7 \times (10 + j50) \Omega}{1 - 0.7^2} \right $
--	---

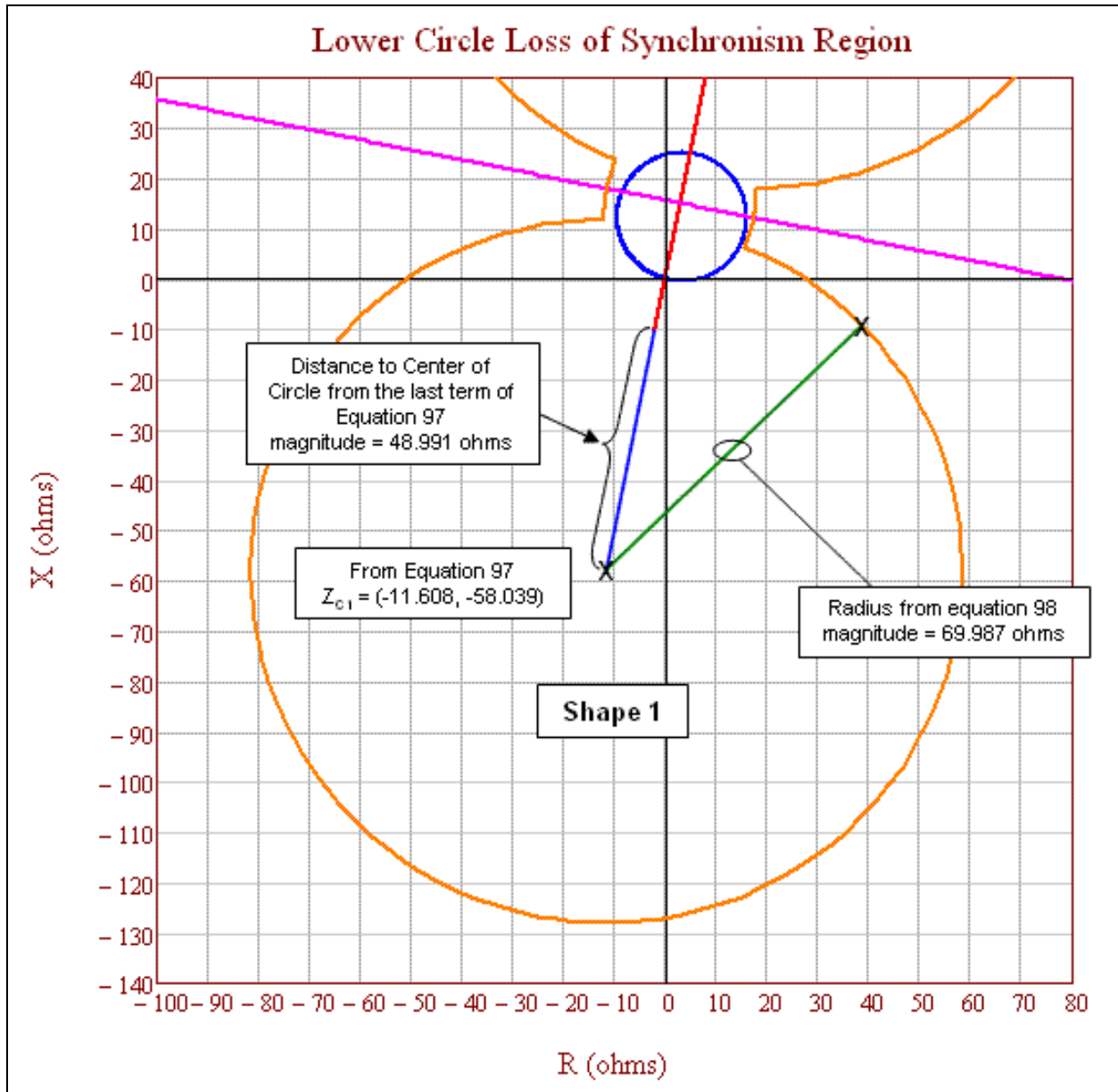
	$r_a = 69.987 \Omega$
--	-----------------------

The calculated coordinates of the upper loss-of-synchronism circle center.

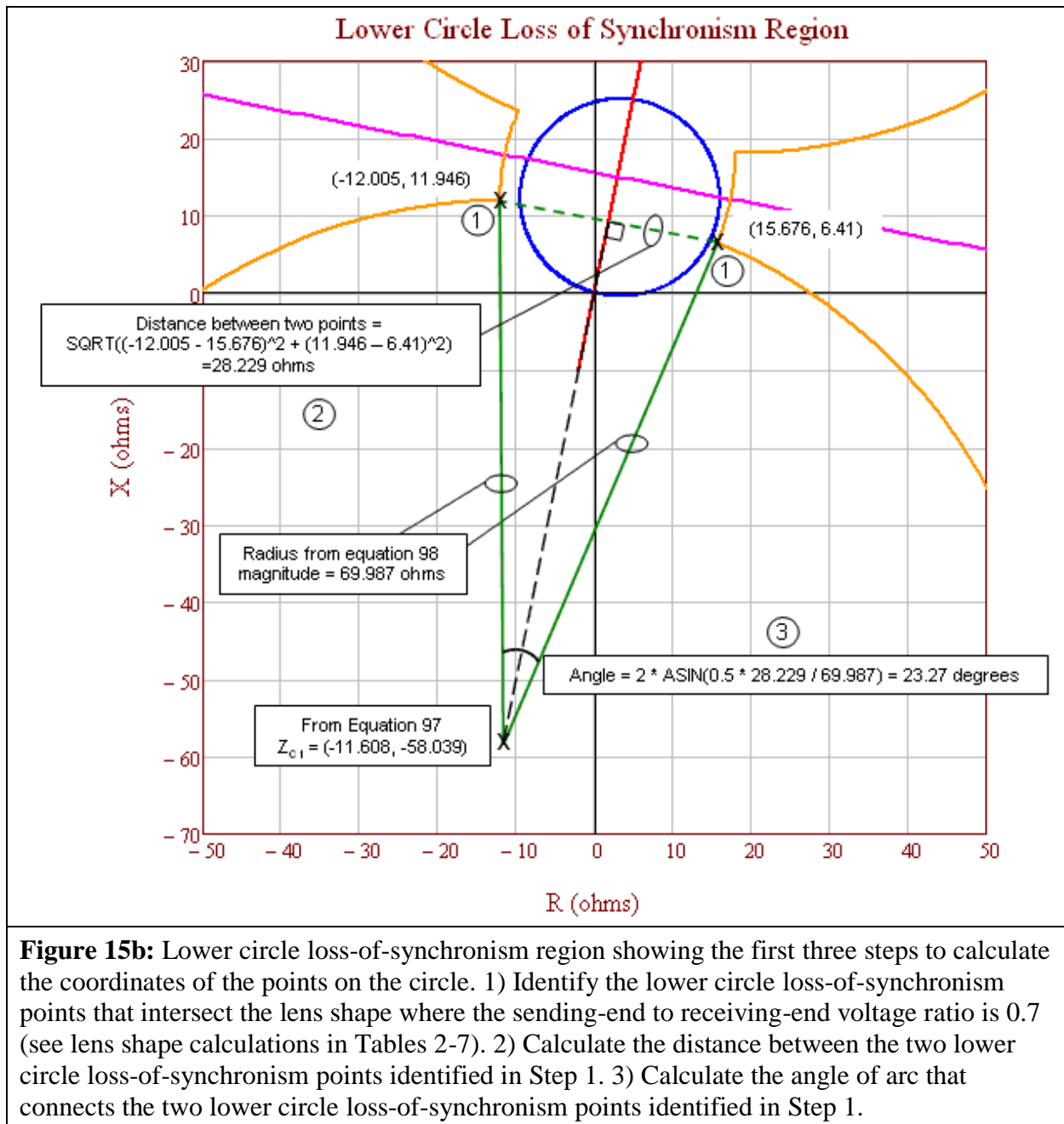
Given:	$E_S = 1.0$	$E_R = 0.7$
--------	-------------	-------------

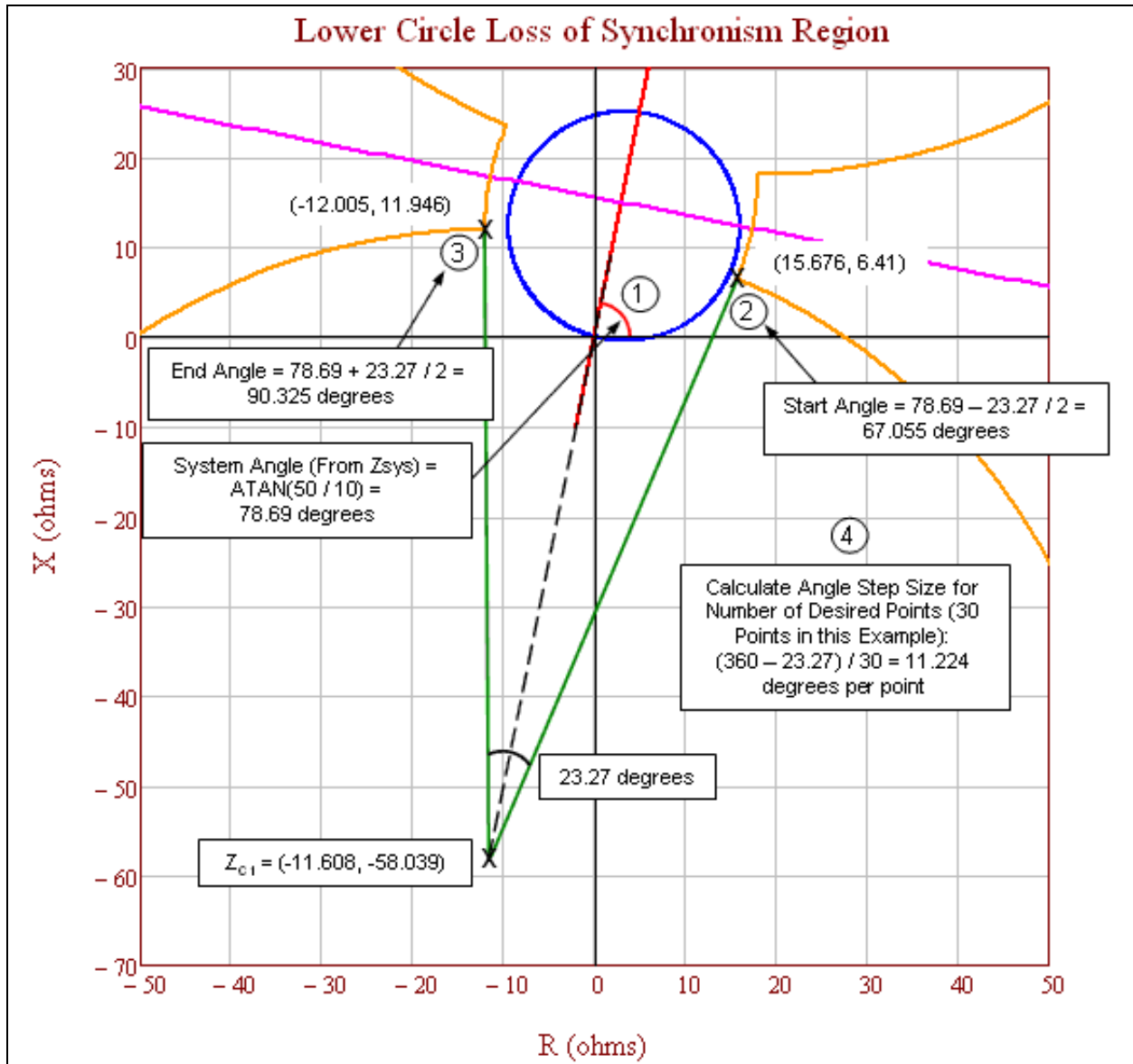
<sup>18</sup> <http://store.gedigitalenergy.com/faq/Documents/Alps/GER-3180.pdf>

Table 13: Example Calculation (Voltage Ratios)	
Eq. (99)	$N = \frac{ E_S }{ E_R } = \frac{1.0}{0.7} = 1.43$
Eq. (100)	$Z_{C2} = Z_L + \left[ Z_R \times \left( 1 + \frac{Z_L}{Z_{TR}} \right) \right] + \left[ \frac{Z_{sys}}{N^2 - 1} \right]$
	$Z_{C2} = 4 + j20 \Omega + \left[ (4 + j20) \Omega \times \left( 1 + \frac{(4 + j20) \Omega}{(4 + j20) \times 10^{10} \Omega} \right) \right] + \left[ \frac{(10 + j50) \Omega}{1.43^2 - 1} \right]$
	$Z_{C2} = 17.608 + j88.039 \Omega$
The calculated radius of the upper loss-of-synchronism circle.	
Eq. (101)	$r_b = \left  \frac{N \times Z_{sys}}{N^2 - 1} \right $
	$r_b = \left  \frac{1.43 \times (10 + j50) \Omega}{1.43^2 - 1} \right $
	$r_b = 69.987 \Omega$

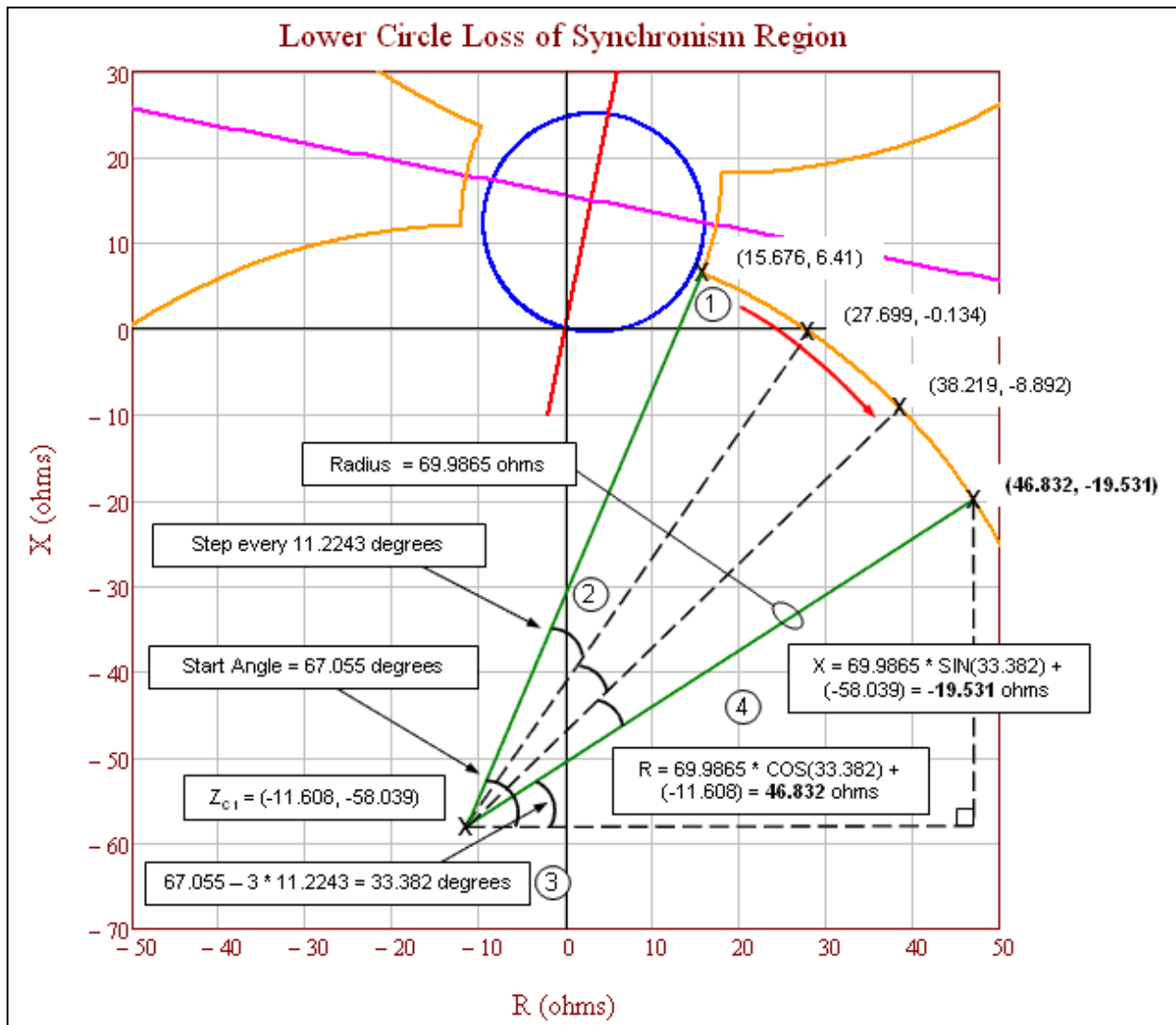


**Figure 15a:** Lower circle loss-of-synchronism region showing the coordinates of the circle center and the circle radius.

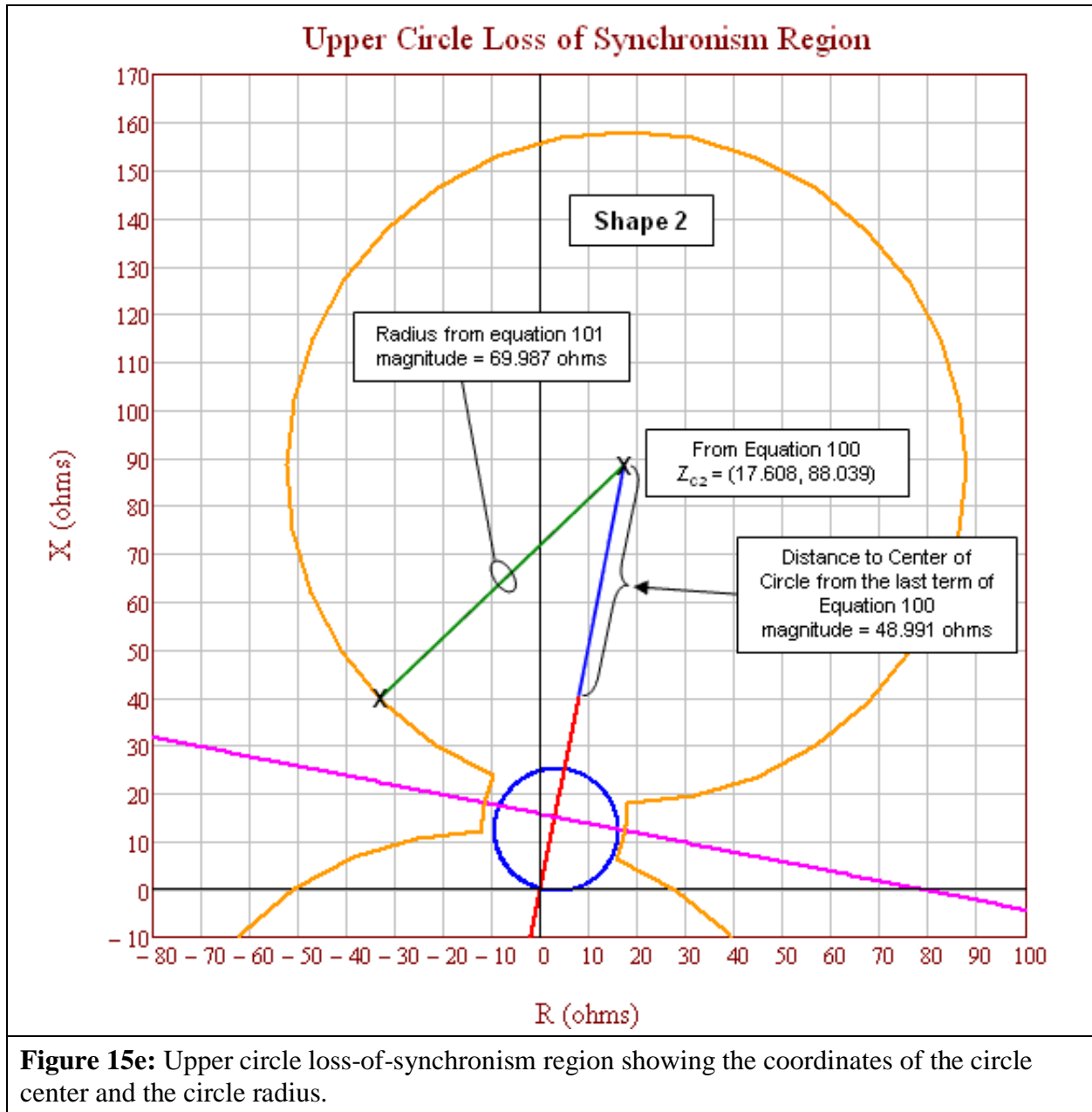




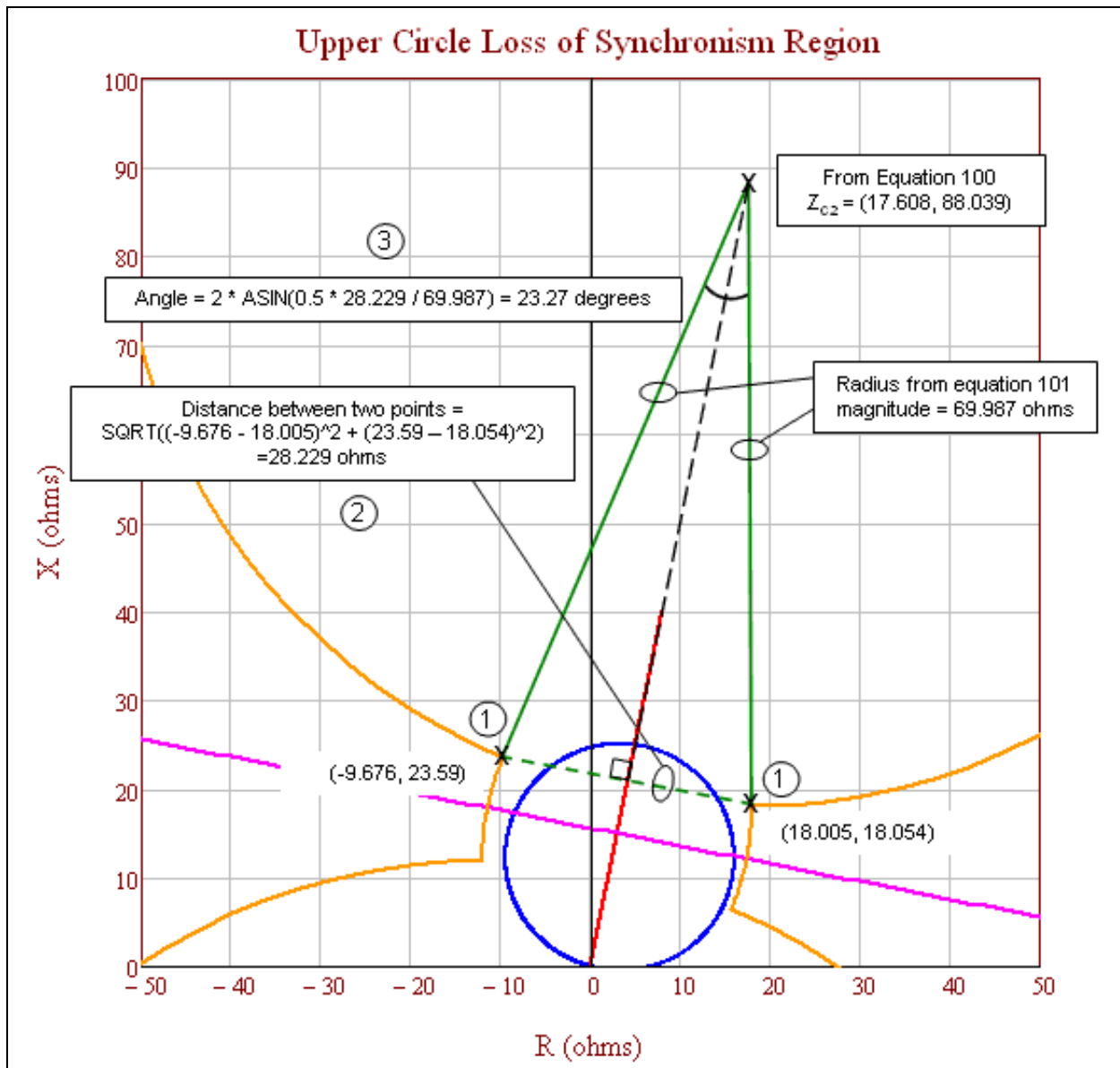
**Figure 15c:** Lower circle loss-of-synchronism region showing the steps to calculate the start angle, end angle, and the angle step size for the desired number of calculated points. 1) Calculate the system angle. 2) Calculate the start angle. 3) Calculate the end angle. 4) Calculate the angle step size for the desired number of points.



**Figure 15d:** Lower circle loss-of-synchronism region showing the final steps to calculate the coordinates of the points on the circle. 1) Start at the intersection with the lens shape and proceed in a clockwise direction. 2) Advance the step angle for each point. 3) Calculate the new angle after step advancement. 4) Calculate the R–X coordinates.

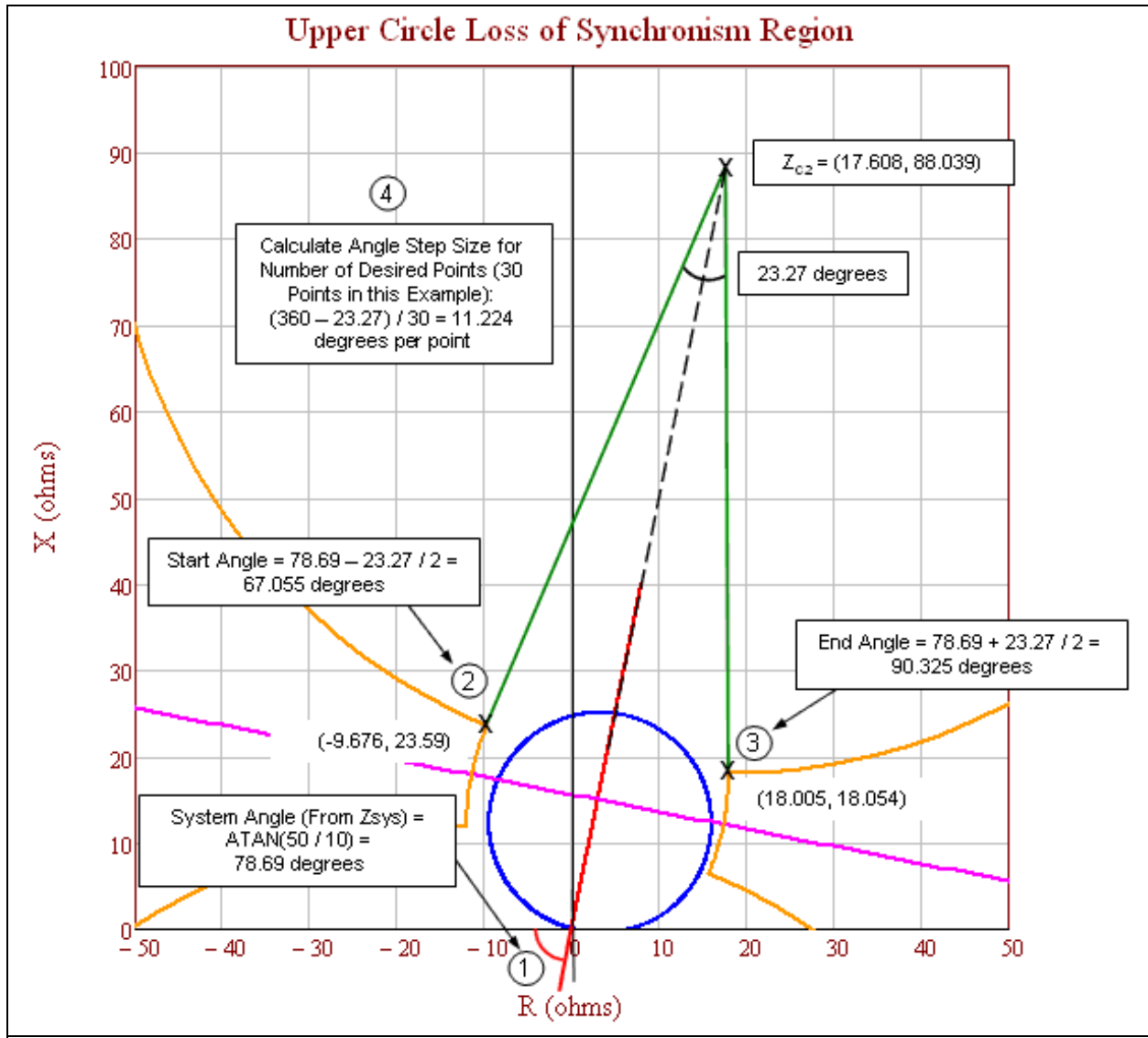


**Figure 15e:** Upper circle loss-of-synchronism region showing the coordinates of the circle center and the circle radius.

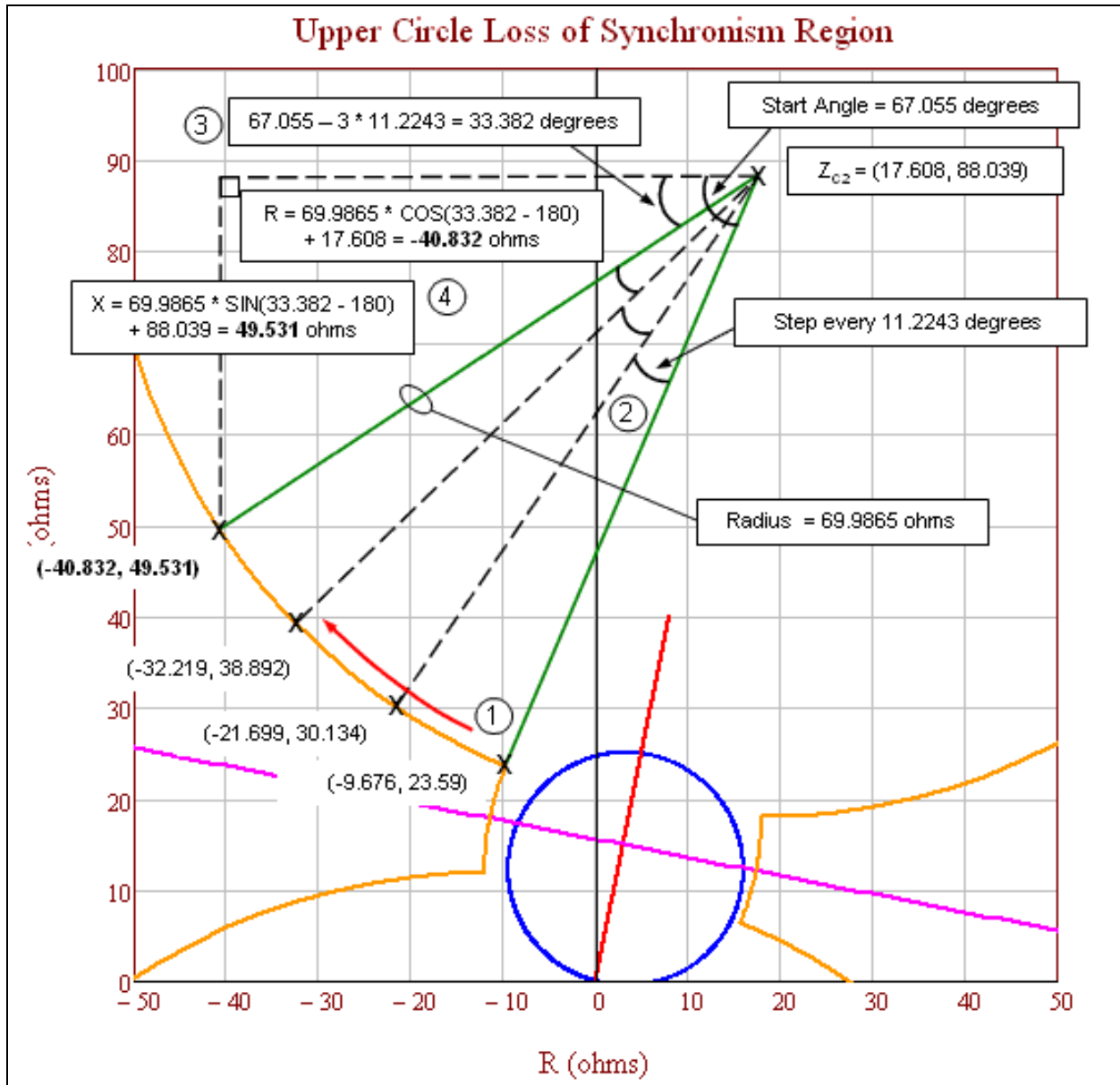


**Figure 15f:** Upper circle loss-of-synchronism region showing the first three steps to calculate the coordinates of the points on the circle. 1) Identify the upper circle points that intersect the lens shape where the sending-end to receiving-end voltage ratio is 1.43 (see lens shape calculations in Tables 2-7). 2) Calculate the distance between the two upper circle points identified in Step 1. 3) Calculate the angle of arc that connects the two upper circle points identified in Step 1.





**Figure 15g:** Upper circle loss-of-synchronism region showing the steps to calculate the start angle, end angle, and the angle step size for the desired number of calculated points. 1) Calculate the system angle. 2) Calculate the start angle. 3) Calculate the end angle. 4) Calculate the angle step size for the desired number of points.



**Figure 15h:** Upper circle loss-of-synchronism region showing the final steps to calculate the coordinates of the points on the circle. 1) Start at the intersection with the lens shape and proceed in a clockwise direction. 2) Advance the step angle for each point. 3) Calculate the new angle after step advancement. 4) Calculate the R-X coordinates.

Lower Loss of Synchronism Circle Coordinates			Upper Loss of Synchronism Circle Coordinates		
Angle (degrees)	R	+ jX	Angle (degrees)	R	+ jX
67.055	15.676	6.41	67.055	-9.676	23.59
55.831	27.699	-0.134	55.831	-21.699	30.134
44.606	38.219	-8.892	44.606	-32.219	38.892
<b>33.382</b>	<b>46.832</b>	<b>-19.531</b>	<b>33.382</b>	<b>-40.832</b>	<b>49.531</b>
22.158	53.21	-31.643	22.158	-47.21	61.643
10.933	57.108	-44.765	10.933	-51.108	74.765
359.709	58.378	-58.395	359.709	-52.378	88.395
348.485	56.97	-72.011	348.485	-50.97	102.011
337.26	52.939	-85.092	337.26	-46.939	115.092
326.036	46.438	-97.139	326.036	-40.438	127.139
314.812	37.717	-107.69	314.812	-31.717	137.69
303.587	27.109	-116.341	303.587	-21.109	146.341
292.363	15.02	-122.762	292.363	-9.02	152.762
281.139	1.913	-126.707	281.139	4.087	156.707
269.914	-11.712	-128.026	269.914	17.712	158.026
258.69	-25.333	-126.667	258.69	31.333	156.667
247.466	-38.429	-122.682	247.466	44.429	152.682
236.241	-50.499	-116.225	236.241	56.499	146.225
225.017	-61.081	-107.542	225.017	67.081	137.542
213.793	-69.771	-96.965	213.793	75.771	126.965
202.568	-76.235	-84.899	202.568	82.235	114.899
191.344	-80.227	-71.806	191.344	86.227	101.806
180.12	-81.594	-58.185	180.12	87.594	88.185
168.895	-80.284	-44.56	168.895	86.284	74.56
157.671	-76.347	-31.45	157.671	82.347	61.45
146.447	-69.933	-19.357	146.447	75.933	49.357
135.222	-61.288	-8.744	135.222	67.288	38.744
123.998	-50.742	-0.016	123.998	56.742	30.016
112.774	-38.699	6.491	112.774	44.699	23.509
101.549	-25.62	10.53	101.549	31.62	19.47
90.325	-12.005	11.946	90.325	18.005	18.054

**Figure 15i:** Full tables of calculated lower and upper loss-of-synchronism circle coordinates. The highlighted row is the detailed calculated points in Figures 15d and 15h.

### Application Specific to Criterion B

The PRC-026-1-2 Attachment B, Criterion B evaluates overcurrent elements used for tripping. The same criteria as PRC-026-1-2 Attachment B, Criterion A is used except for an additional criterion (No. 4) that calculates a current magnitude based upon generator internal voltage of 1.05 per unit. A value of 1.05 per unit generator voltage is used to establish a minimum pickup current value for overcurrent relays that have a time delay less than 15 cycles. The sending-end and receiving-end voltages are established at 1.05 per unit at 120 degree system separation angle. The 1.05 per unit is the typical upper end of the operating voltage, which is also consistent with the

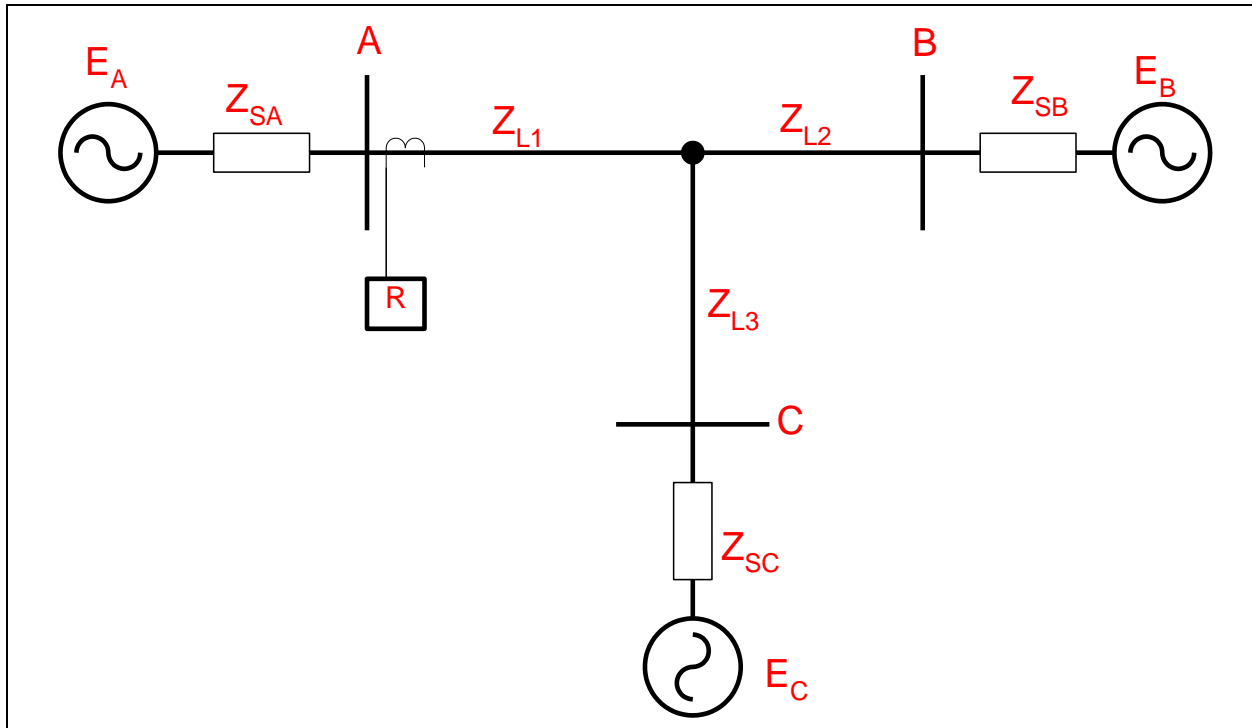
maximum power transfer calculation using actual system source impedances in the PRC-023 NERC Reliability Standard. The formulas used to calculate the current are in Table 14 below.

Table 14: Example Calculation (Overcurrent)			
This example is for a 230 kV line terminal with a directional instantaneous phase overcurrent element set to 50 amps secondary times a CT ratio of 160:1 that equals 8,000 amps, primary. The following calculation is where $V_S$ equals the base line-to-ground sending-end generator source voltage times 1.05 at an angle of 120 degrees, $V_R$ equals the base line-to-ground receiving-end generator internal voltage times 1.05 at an angle of 0 degrees, and $Z_{sys}$ equals the sum of the sending-end source, line, and receiving-end source impedances in ohms.			
Here, the instantaneous phase setting of 8,000 amps is greater than the calculated system current of 5,716 amps; therefore, it meets PRC-026-1.2 – Attachment B, Criterion B.			
Eq. (102)	$V_S = \frac{V_{LL} \angle 120^\circ}{\sqrt{3}} \times 1.05$		
	$V_S = \frac{230,000 \angle 120^\circ V}{\sqrt{3}} \times 1.05$		
	$V_S = 139,430 \angle 120^\circ V$		
Receiving-end generator terminal voltage.			
Eq. (103)	$V_R = \frac{V_{LL} \angle 0^\circ}{\sqrt{3}} \times 1.05$		
	$V_R = \frac{230,000 \angle 0^\circ V}{\sqrt{3}} \times 1.05$		
	$V_R = 139,430 \angle 0^\circ V$		
The total impedance of the system ( $Z_{sys}$ ) equals the sum of the sending-end source impedance ( $Z_S$ ), the impedance of the line ( $Z_L$ ), and receiving-end impedance ( $Z_R$ ) in ohms.			
Given:	$Z_S = 3 + j26 \Omega$	$Z_L = 1.3 + j8.7 \Omega$	$Z_R = 0.3 + j7.3 \Omega$
Eq. (104)	$Z_{sys} = Z_S + Z_L + Z_R$		
	$Z_{sys} = (3 + j26) \Omega + (1.3 + j8.7) \Omega + (0.3 + j7.3) \Omega$		
	$Z_{sys} = 4.6 + j42 \Omega$		
Total system current.			
Eq. (105)	$I_{sys} = \frac{(V_S - V_R)}{Z_{sys}}$		
	$I_{sys} = \frac{(139,430 \angle 120^\circ V - 139,430 \angle 0^\circ V)}{(4.6 + j42) \Omega}$		
	$I_{sys} = 5,715.82 \angle 66.25^\circ A$		

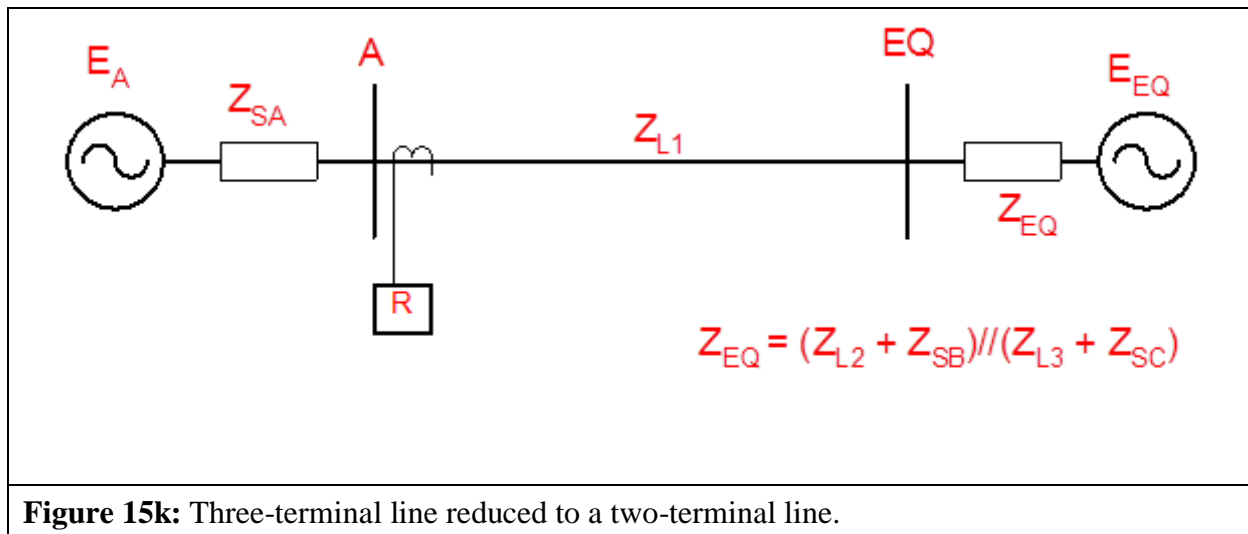
### Application Specific to Three-Terminal Lines

If a three-terminal line is identified as an Element that is susceptible to a power swing based on Requirement R1, the load-responsive protective relays at each end of the three-terminal line must be evaluated.

As shown in Figure 15j, the source impedances at each end of the line can be obtained from the similar short circuit calculation as for the two-terminal line (assuming the parallel transfer impedances are ignored).



**Figure 15j:** Three-terminal line. To evaluate the load-responsive protective relays on the three-terminal line at Terminal A, the circuit in Figure 15j is first reduced to the equivalent circuit shown in Figure 15k. The evaluation process for the load-responsive protective relays on the line at Terminal A will now be the same as that of the two-terminal line.



**Figure 15k:** Three-terminal line reduced to a two-terminal line.

### Application to Generation Elements

As with transmission BES Elements, the determination of the apparent impedance seen at an Element located at, or near, a generation Facility is complex for power swings due to various interdependent quantities. These variances in quantities are caused by changes in machine internal voltage, speed governor action, voltage regulator action, the reaction of other local generators, and the reaction of other interconnected transmission BES Elements as the event progresses through the time domain. Though transient stability simulations may be used to determine the apparent impedance for verifying load-responsive relay settings,<sup>19,20</sup> Requirement R2, PRC-026-1-2 – Attachment B, Criteria A and B provides a simplified method for evaluating the load-responsive protective relay’s susceptibility to tripping in response to a stable power swing without requiring stability simulations.

In general, the electrical center will be in the transmission system for cases where the generator is connected through a weak transmission system (high external impedance). In other cases where the generator is connected through a strong transmission system, the electrical center could be inside the unit connected zone.<sup>21</sup> In either case, load-responsive protective relays connected at the generator terminals or at the high-voltage side of the generator step-up (GSU) transformer may be challenged by power swings. Relays that may be challenged by power swings will be determined by the Planning Coordinator in Requirement R1 or by the Generator Owner after becoming aware of a generator, transformer, or transmission line BES Element that tripped<sup>22</sup> in response to a stable or unstable power swing due to the operation of its protective relay(s) in Requirement R2.

<sup>19</sup> Donald Reimert, *Protective Relaying for Power Generation Systems*, Boca Raton, FL, CRC Press, 2006.

<sup>20</sup> Prabha Kundur, *Power System Stability and Control*, EPRI, McGraw Hill, Inc., 1994.

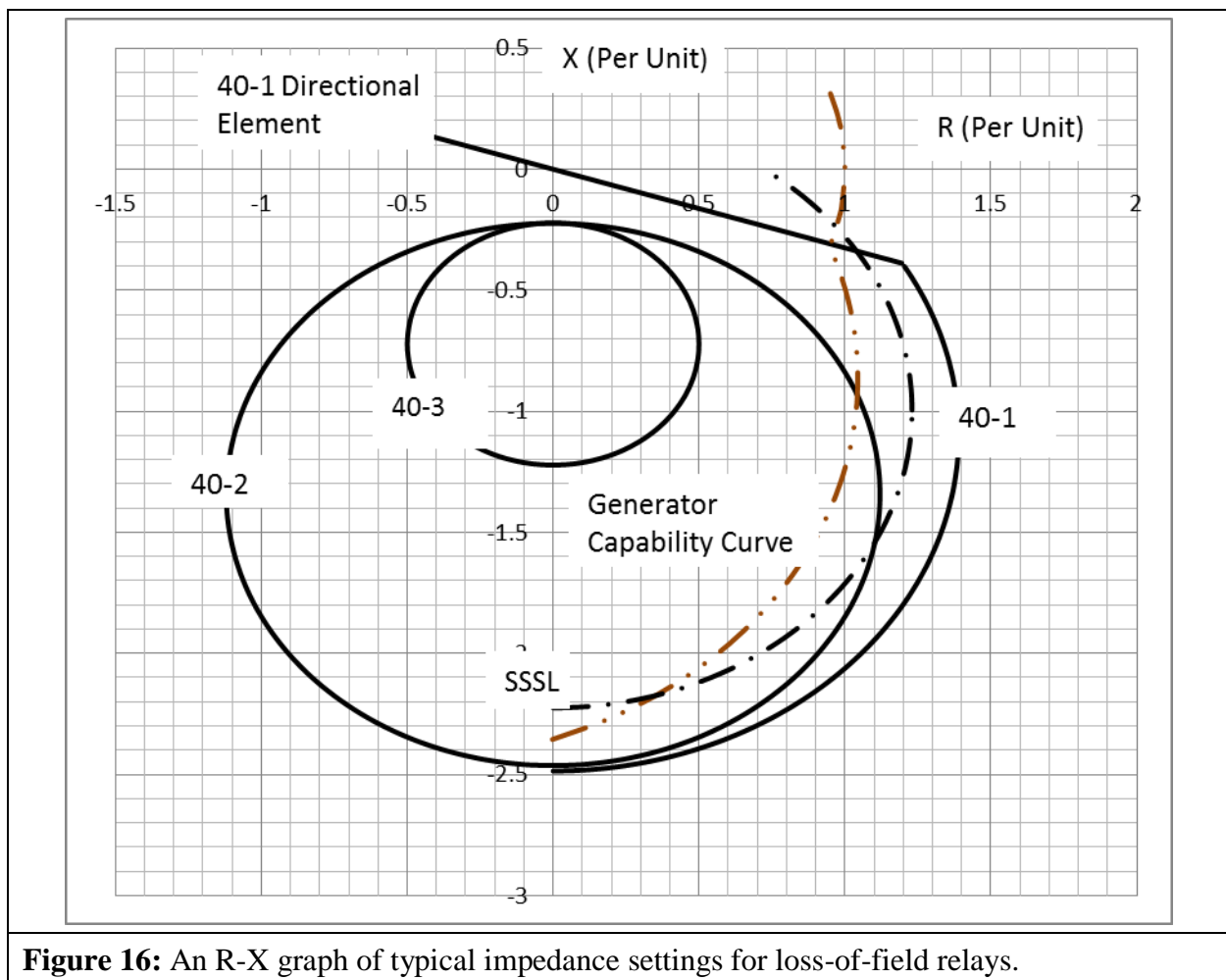
<sup>21</sup> Ibid, Kundur.

<sup>22</sup> See Guidelines and Technical Basis section, “Becoming Aware of an Element That Tripped in Response to a Power Swing,”

Voltage controlled time-overcurrent and voltage-restrained time-overcurrent relays are excluded from this standard. When these relays are set based on equipment permissible overload capability, their operating times are much greater than 15 cycles for the current levels observed during a power swing.

Instantaneous overcurrent, time-overcurrent, and definite-time overcurrent relays with a time delay of less than 15 cycles for the current levels observed during a power swing are applicable and are required to be evaluated for identified Elements.

The generator loss-of-field protective function is provided by impedance relay(s) connected at the generator terminals. The settings are applied to protect the generator from a partial or complete loss of excitation under all generator loading conditions and, at the same time, be immune to tripping on stable power swings. It is more likely that the loss-of-field relay would operate during a power swing when the automatic voltage regulator (AVR) is in manual mode rather than when in automatic mode.<sup>23</sup> Figure 16 illustrates the loss-of-field relay in the R-X plot, which typically includes up to three zones of protection.



**Figure 16:** An R-X graph of typical impedance settings for loss-of-field relays.

<sup>23</sup> John Burdy, *Loss-of-excitation Protection for Synchronous Generators GER-3183*, General Electric Company.

Loss-of-field characteristic 40-1 has a wider impedance characteristic (positive offset) than characteristic 40-2 or characteristic 40-3 and provides additional generator protection for a partial loss of field or a loss of field under low load (less than 10% of rated). The tripping logic of this protection scheme is established by a directional contact, a voltage setpoint, and a time delay. The voltage and time delay add security to the relay operation for stable power swings. Characteristic 40-3 is less sensitive to power swings than characteristic 40-2 and is set outside the generator capability curve in the leading direction. Regardless of the relay impedance setting, PRC-019<sup>24</sup> requires that the “in-service limiters operate before Protection Systems to avoid unnecessary trip” and “in-service Protection System devices are set to isolate or de-energize equipment in order to limit the extent of damage when operating conditions exceed equipment capabilities or stability limits.” Time delays for tripping associated with loss-of-field relays<sup>25,26</sup> have a range from 15 cycles for characteristic 40-2 to 60 cycles for characteristic 40-1 to minimize tripping during stable power swings. In PRC-026-1<sup>2</sup>, 15 cycles establishes a threshold for applicability; however, it is the responsibility of the Generator Owner to establish settings that provide security against stable power swings and, at the same time, dependable protection for the generator.

The simple two-machine system circuit (method also used in the Application to Transmission Elements section) is used to analyze the effect of a power swing at a generator facility for load-responsive relays. In this section, the calculation method is used for calculating the impedance seen by the relay connected at a point in the circuit.<sup>27</sup> The electrical quantities used to determine the apparent impedance plot using this method are generator saturated transient reactance ( $X'_d$ ), GSU transformer impedance ( $X_{GSU}$ ), transmission line impedance ( $Z_L$ ), and the system equivalent ( $Z_e$ ) at the point of interconnection. All impedance values are known to the Generator Owner except for the system equivalent. The system equivalent is obtainable from the Transmission Owner. The sending-end and receiving-end source voltages are varied from 0.0 to 1.0 per unit to form the lens shape portion of the unstable power swing region. The voltage range of 0.7 to 1.0 results in a ratio range from 0.7 to 1.43. This ratio range is used to form the lower and upper loss-of-synchronism circle shapes of the unstable power swing region. A system separation angle of 120 degrees is used in accordance with PRC-026-1<sup>2</sup> – Attachment B criteria for each load-responsive protective relay evaluation.

Table 15 below is an example calculation of the apparent impedance locus method based on Figures 17 and 18.<sup>28</sup> In this example, the generator is connected to the 345 kV transmission system through the GSU transformer and has the listed ratings. Note that the load-responsive protective relays in this example may have ownership with the Generator Owner or the Transmission Owner.

<sup>24</sup> Coordination of Generating Unit or Plant Capabilities, Voltage Regulating Controls, and Protection

<sup>25</sup> Ibid, Burdy.

<sup>26</sup> *Applied Protective Relaying*, Westinghouse Electric Corporation, 1979.

<sup>27</sup> Edward Wilson Kimbark, *Power System Stability, Volume II: Power Circuit Breakers and Protective Relays*, Published by John Wiley and Sons, 1950.

<sup>28</sup> Ibid, Kimbark.



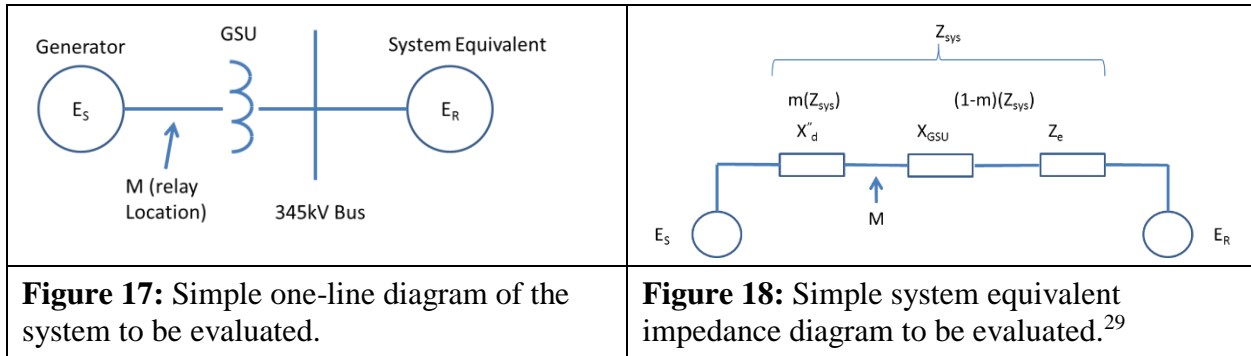


Table15: Example Data (Generator)	
Input Descriptions	Input Values
Synchronous Generator nameplate (MVA)	940 MVA
Saturated transient reactance (940 MVA base)	$X'_d = 0.3845$ per unit
Generator rated voltage (Line-to-Line)	20 kV
Generator step-up (GSU) transformer rating	880 MVA
GSU transformer reactance (880 MVA base)	$X_{GSU} = 16.05\%$
System Equivalent (100 MVA base)	$Z_e = 0.00723 \angle 90^\circ$ per unit
Generator Owner Load-Responsive Protective Relays	
40-1	Positive Offset Impedance
	Offset = 0.294 per unit
	Diameter = 0.294 per unit
40-2	Negative Offset Impedance
	Offset = 0.22 per unit
	Diameter = 2.24 per unit
40-3	Negative Offset Impedance
	Offset = 0.22 per unit
	Diameter = 1.00 per unit
21-1	Diameter = 0.643 per unit
	MTA = 85°

<sup>29</sup> Ibid, Kimbark.

Table15: Example Data (Generator)	
50	I (pickup) = 5.0 per unit
<b>Transmission Owned Load-Responsive Protective Relays</b>	
21-2	Diameter = 0.55 per unit
	MTA = 85°

Calculations shown for a 120 degree angle and  $E_S/E_R = 1$ . The equation for calculating  $Z_R$  is:<sup>30</sup>

$$\text{Eq. (106)} \quad Z_R = \left( \frac{(1 - m)(E_S \angle \delta) + (m)(E_R)}{E_S \angle \delta - E_R} \right) \times Z_{sys}$$

Where m is the relay location as a function of the total impedance (real number less than 1)

$E_S$  and  $E_R$  is the sending-end and receiving-end voltages

$Z_{sys}$  is the total system impedance

$Z_R$  is the complex impedance at the relay location and plotted on an R-X diagram

All of the above are constants (940 MVA base) while the angle  $\delta$  is varied. Table 16 below contains calculations for a generator using the data listed in Table 15.

Table16: Example Calculations (Generator)			
The following calculations are on a 940 MVA base.			
Given:	$X'_d = j0.3845 pu$	$X_{GSU} = j0.17144 pu$	$Z_e = j0.06796 pu$
Eq. (107)	$Z_{sys} = X'_d + X_{GSU} + Z_e$		
	$Z_{sys} = j0.3845 pu + j0.17144 pu + j0.06796 pu$		
	$Z_{sys} = 0.6239 \angle 90^\circ pu$		
Eq. (108)	$m = \frac{X'_d}{Z_{sys}} = \frac{0.3845}{0.6239} = 0.6163$		
Eq. (109)	$Z_R = \left( \frac{(1 - m)(E_S \angle \delta) + (m)(E_R)}{E_S \angle \delta - E_R} \right) \times Z_{sys}$		
	$Z_R = \left( \frac{(1 - 0.6163) \times (1 \angle 120^\circ) + (0.6163)(1 \angle 0^\circ)}{1 \angle 120^\circ - 1 \angle 0^\circ} \right) \times (0.6239 \angle 90^\circ) pu$		

<sup>30</sup> Ibid, Kimbark.

Table16: Example Calculations (Generator)	
	$Z_R = \left( \frac{0.4244 + j0.3323}{-1.5 + j 0.866} \right) \times (0.6239 \angle 90^\circ) pu$
	$Z_R = (0.3116 \angle -111.95^\circ) \times (0.6239 \angle 90^\circ) pu$
	$Z_R = 0.194 \angle -21.95^\circ pu$
	$Z_R = -0.18 - j0.073 pu$

Table 17 lists the swing impedance values at other angles and at  $E_S/E_R = 1, 1.43,$  and  $0.7$ . The impedance values are plotted on an R-X graph with the center being at the generator terminals for use in evaluating impedance relay settings.

Table 17: Sample Calculations for a Swing Impedance Chart for Varying Voltages at the Sending-End and Receiving-End.						
Angle ( $\delta$ ) (Degrees)	$E_S/E_R=1$		$E_S/E_R=1.43$		$E_S/E_R=0.7$	
	$Z_R$		$Z_R$		$Z_R$	
	Magnitude (pu)	Angle (Degrees)	Magnitude (pu)	Angle (Degrees)	Magnitude (pu)	Angle (Degrees)
90	0.320	-13.1	0.296	6.3	0.344	-31.5
120	0.194	-21.9	0.173	-0.4	0.227	-40.1
150	0.111	-41.0	0.082	-10.3	0.154	-58.4
210	0.111	-25.9	0.082	190.3	0.154	238.4
240	0.194	201.9	0.173	180.4	0.225	220.1
270	0.320	193.1	0.296	173.7	0.344	211.5

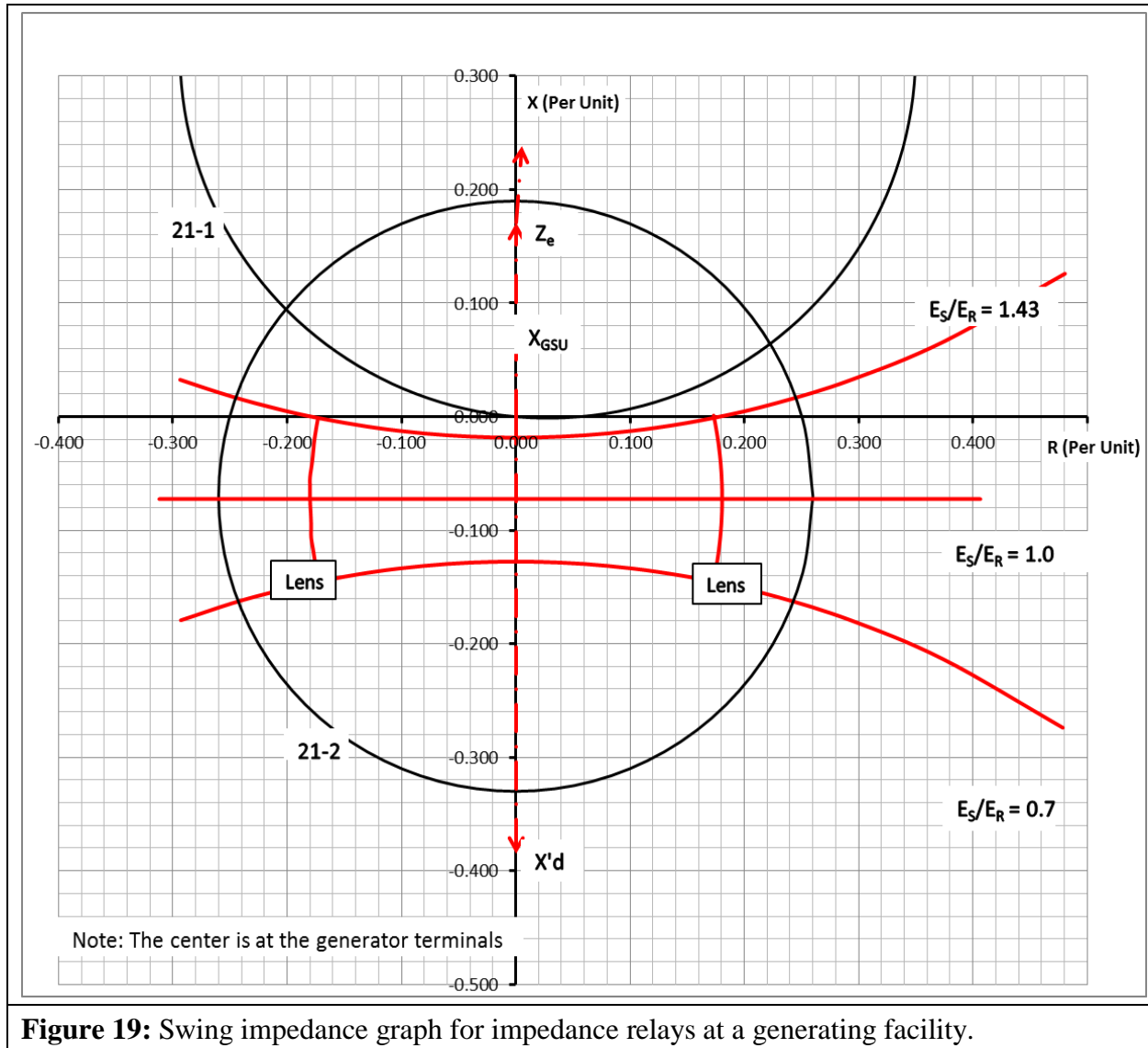
## Requirement R2 Generator Examples

### Distance Relay Application

Based on PRC-026-~~1~~2- Attachment B, Criterion A, the distance relay (21-1) (i.e., owned by the Generation Owner) characteristic is in the region where a stable power swing would not occur as shown in Figure 19. There is no further obligation to the owner in this standard for this load-responsive protective relay.

The distance relay (21-2) (i.e., owned by the Transmission Owner) is connected at the high-voltage side of the GSU transformer and its impedance characteristic is in the region where a stable power swing could occur causing the relay to operate. In this example, if the intentional time delay of this relay is less than 15 cycles, the PRC-026 – Attachment B, Criterion A cannot be met, thus the Transmission Owner is required to create a CAP (Requirement R3). Some of the options include,

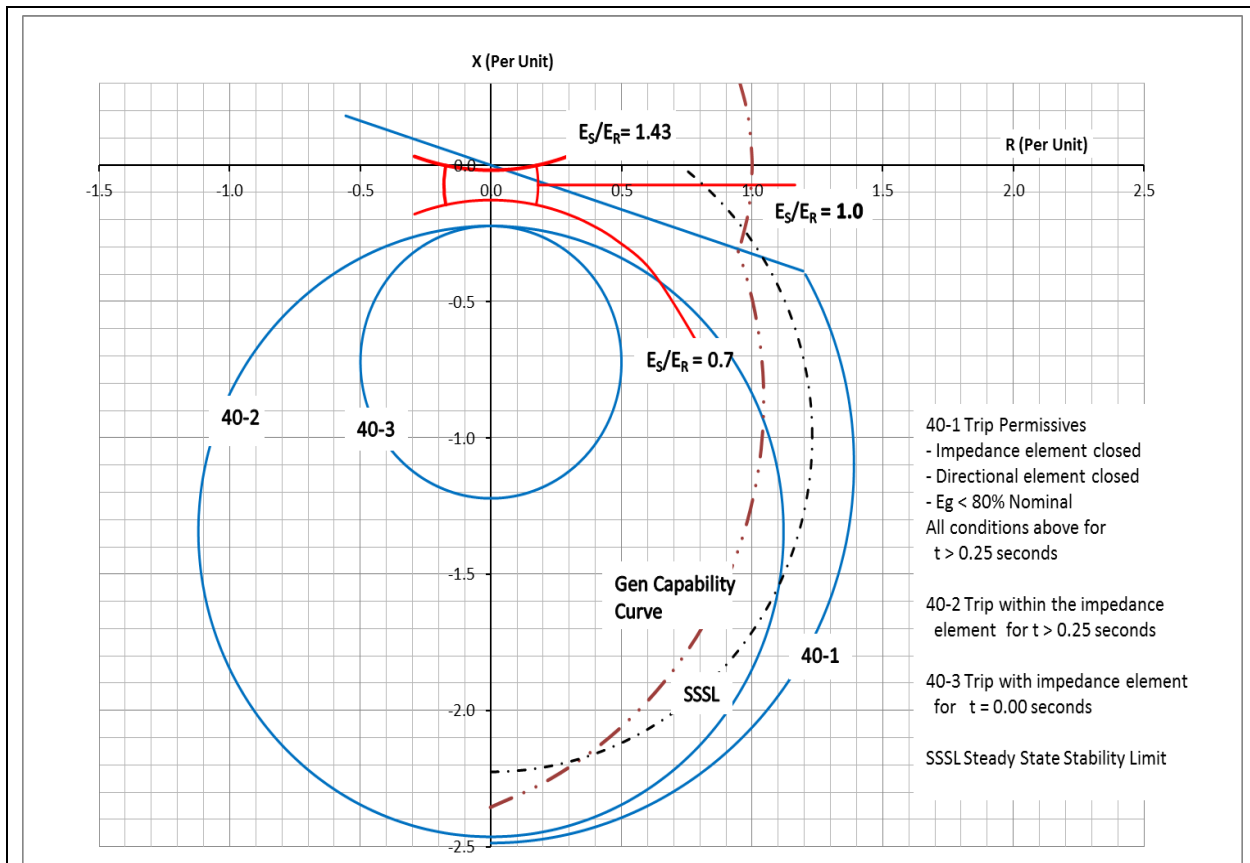
but are not limited to, changing the relay setting (i.e., impedance reach, angle, time delay), modify the scheme (i.e., add PSB), or replace the Protection System. Note that the relay may be excluded from this standard if it has an intentional time delay equal to or greater than 15 cycles.



### Loss-of-Field Relay Application

In Figure 20, the R-X diagram shows the loss-of-field relay (40-1 and 40-2) characteristics are in the region where a stable power swing can cause a relay operation. Protective relay 40-1 would be excluded if it has an intentional time delay equal to or greater than 15 cycles. Similarly, 40-2 would be excluded if its intentional time delay is equal to or greater than 15 cycles. For example, if 40-1 has a time delay of 1 second and 40-2 has a time delay of 0.25 seconds, they are excluded and there is no further obligation on the Generator Owner in this standard for these relays. The

loss-of-field relay characteristic 40-3 is entirely inside the unstable power swing region. In this case, the owner may select high speed tripping on operation of the 40-3 impedance element.



**Figure 20:** Typical R-X graph for loss-of-field relays with a portion of the unstable power swing region defined by PRC-026-1-2 – Attachment B, Criterion A.

### Instantaneous Overcurrent Relay

In similar fashion to the transmission line overcurrent example calculation in Table 14, the instantaneous overcurrent relay minimum setting is established by PRC-026-1-2 – Attachment B, Criterion B. The solution is found by:

$$\text{Eq. (110)} \quad I_{sys} = \frac{E_S - E_R}{Z_{sys}}$$

As stated in the relay settings in Table 15, the relay is installed on the high-voltage side of the GSU transformer with a pickup of 5.0 per unit. The maximum allowable current is calculated below.

$$I_{sys} = \frac{(1.05 \angle 120^\circ - 1.05 \angle 0^\circ)}{0.6239 \angle 90^\circ} pu$$

$$I_{sys} = \frac{1.819 \angle 150^\circ}{0.6239 \angle 90^\circ} pu$$

$$I_{sys} = 2.91 \angle 60^\circ pu$$

The instantaneous phase setting of 5.0 per unit is greater than the calculated system current of 2.91 per unit; therefore, it meets the PRC-026-~~1~~2 – Attachment B, Criterion B.

### **Out-of-Step Tripping for Generation Facilities**

Out-of-step protection for the generator generally falls into three different schemes. The first scheme is a distance relay connected at the high-voltage side of the GSU transformer with the directional element looking toward the generator. Because this relay setting may be the same setting used for generator backup protection (see Requirement R2 Generator Examples, Distance Relay Application), it is susceptible to tripping in response to stable power swings and would require modification. Because this scheme is susceptible to tripping in response to stable power swings and any modification to the mho circle will jeopardize the overall protection of the out-of-step protection of the generator, available technical literature does not recommend using this scheme specifically for generator out-of-step protection. The second and third out-of-step Protection System schemes are commonly referred to as single and double blinder schemes. These schemes are installed or enabled for out-of-step protection using a combination of blinders, a mho element, and timers. The combination of these protective relay functions provides out-of-step protection and discrimination logic for stable and unstable power swings. Single blinder schemes use logic that discriminate between stable and unstable power swings by issuing a trip command after the first slip cycle. Double blinder schemes are more complex than the single blinder scheme and, depending on the settings of the inner blinder, a trip for a stable power swing may occur. While the logic discriminates between stable and unstable power swings in either scheme, it is important that the trip initiating blinders be set at an angle greater than the stability limit of 120 degrees to remove the possibility of a trip for a stable power swing. Below is a discussion of the double blinder scheme.

### **Double Blinder Scheme**

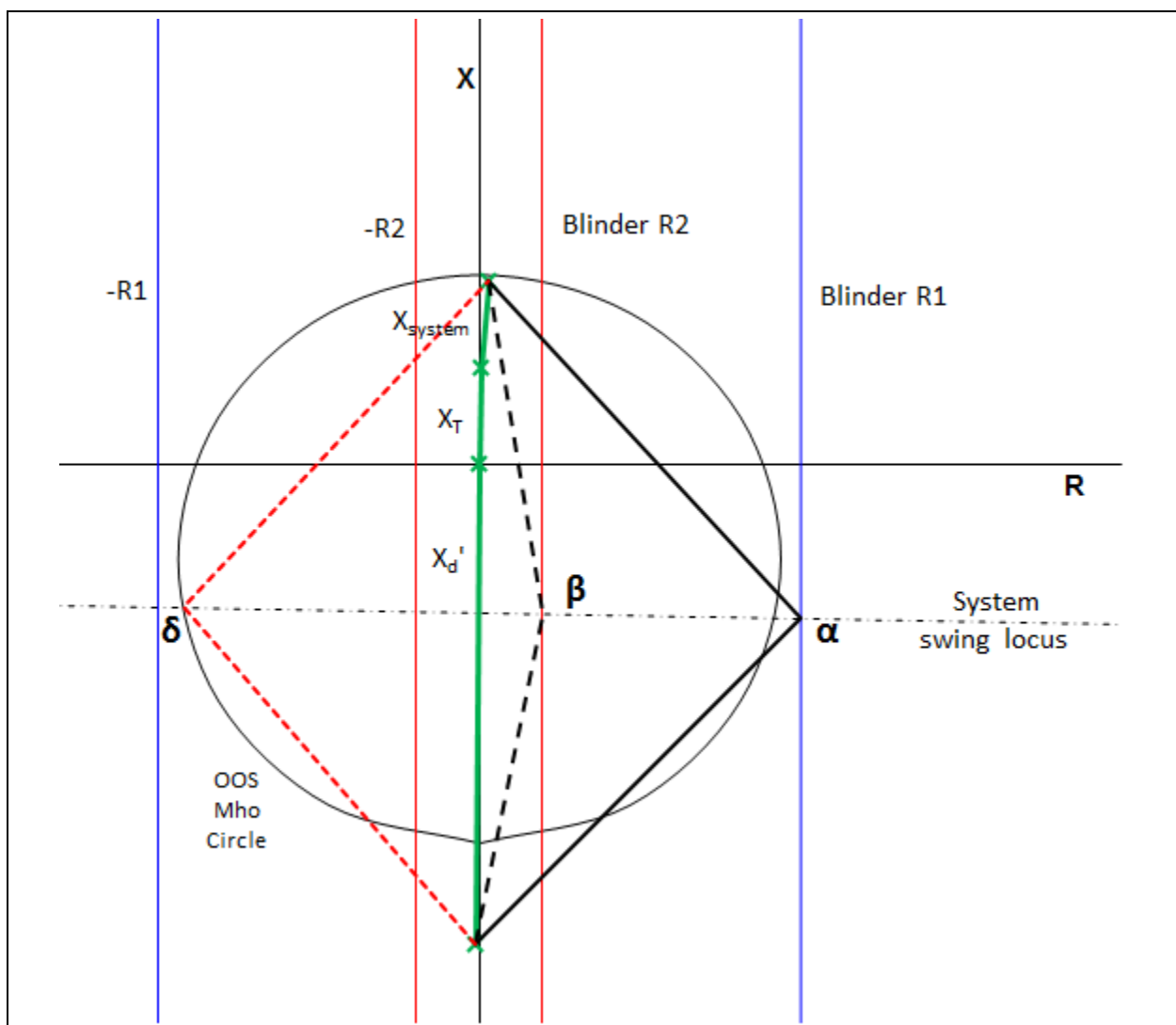
The double blinder scheme is a method for measuring the rate of change of positive sequence impedance for out-of-step swing detection. The scheme compares a timer setting to the actual elapsed time required by the impedance locus to pass between two impedance characteristics. In this case, the two impedance characteristics are simple blinders, each set to a specific resistive reach on the R-X plane. Typically, the two blinders on the left half plane are the mirror images of those on the right half plane. The scheme typically includes a mho characteristic which acts as a starting element, but is not a tripping element.

The scheme detects the blinder crossings and time delays as represented on the R-X plane as shown in Figure 21. The system impedance is composed of the generator transient ( $X_d'$ ), GSU transformer ( $X_T$ ), and transmission system ( $X_{system}$ ), impedances.

The scheme logic is initiated when the swing locus crosses the outer Blinder R1 (Figure 21), on the right at separation angle  $\alpha$ . The scheme only commits to take action when a swing crosses the

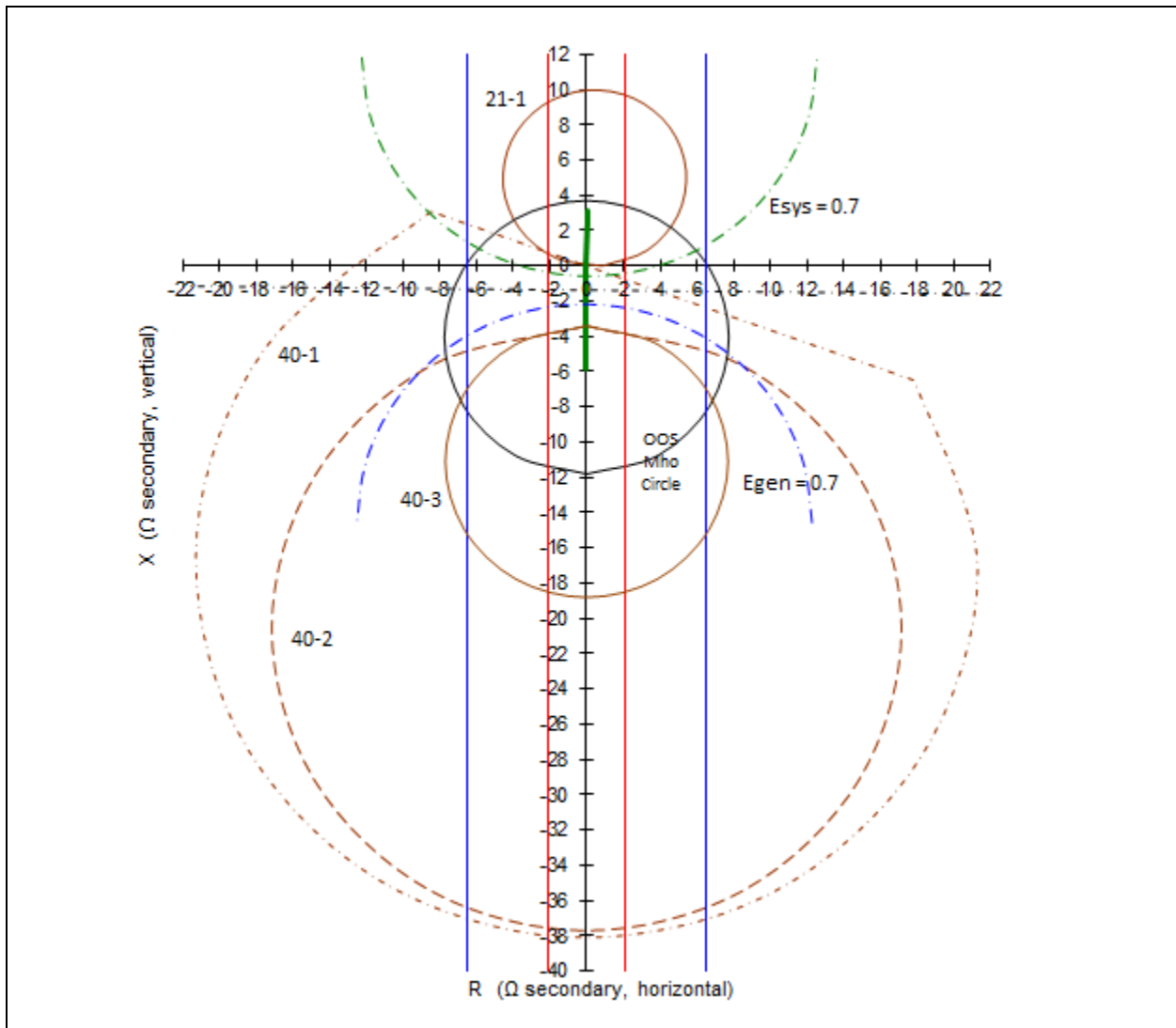
inner blinder. At this point the scheme logic seals in the out-of-step trip logic at separation angle  $\beta$ . Tripping actually asserts as the impedance locus leaves the scheme characteristic at separation angle  $\delta$ .

The power swing may leave both inner and outer blinders in either direction, and tripping will assert. Therefore, the inner blinder must be set such that the separation angle  $\beta$  is large enough that the system cannot recover. This angle should be set at 120 degrees or more. Setting the angle greater than 120 degrees satisfies the PRC-026-1 Attachment B, Criterion A (No. 1, 1<sup>st</sup> bullet) since the tripping function is asserted by the blinder element. Transient stability studies may indicate that a smaller stability limit angle is acceptable under PRC-026-1 Attachment B, Criterion A (No. 1, 2<sup>nd</sup> bullet). In this respect, the double blinder scheme is similar to the double lens and triple lens schemes and many transmission application out-of-step schemes.



**Figure 21:** Double Blinder Scheme generic out of step characteristics.

Figure 22 illustrates a sample setting of the double blinder scheme for the example 940 MVA generator. The only setting requirement for this relay scheme is the right inner blinder, which must be set greater than the separation angle of 120 degrees (or a lesser angle based on a transient stability study) to ensure that the out-of-step protective function is expected to not trip in response to a stable power swing during non-Fault conditions. Other settings such as the mho characteristic, outer blinders, and timers are set according to transient stability studies and are not a part of this standard.



**Figure 22:** Double Blinder Out-of-Step Scheme with unit impedance data and load-responsive protective relay impedance characteristics for the example 940 MVA generator, scaled in relay secondary ohms.



## Requirement R3

To achieve the stated purpose of this standard, which is to ensure that relays are expected to not trip in response to stable power swings during non-Fault conditions, this Requirement ensures that the applicable entity develops a Corrective Action Plan (CAP) that reduces the risk of relays tripping in response to a stable power swing during non-Fault conditions that may occur on any applicable BES Element.

## Requirement R4

To achieve the stated purpose of this standard, which is to ensure that load-responsive protective relays are expected to not trip in response to stable power swings during non-Fault conditions, the applicable entity is required to implement any CAP developed pursuant to Requirement R3 such that the Protection System will meet PRC-026-~~12~~ – Attachment B criteria or can be excluded under the PRC-026-~~12~~ – Attachment A criteria (e.g., modifying the Protection System so that relay functions are supervised by power swing blocking or using relay systems that are immune to power swings), while maintaining dependable fault detection and dependable out-of-step tripping (if out-of-step tripping is applied at the terminal of the BES Element). Protection System owners are required in the implementation of a CAP to update it when actions or timetable change, until all actions are complete. Accomplishing this objective is intended to reduce the occurrence of Protection System tripping during a stable power swing, thereby improving reliability and minimizing risk to the BES.

The following are examples of actions taken to complete CAPs for a relay that did not meet PRC-026-~~12~~ – Attachment B and could be at-risk of tripping in response to a stable power swing during non-Fault conditions. A Protection System change was determined to be acceptable (without diminishing the ability of the relay to protect for faults within its zone of protection).

**Example R4a:** Actions: Settings were issued on 6/02/2015 to reduce the Zone 2 reach of the impedance relay used in the directional comparison unblocking (DCUB) scheme from 30 ohms to 25 ohms so that the relay characteristic is completely contained within the lens characteristic identified by the criterion. The settings were applied to the relay on 6/25/2015. CAP was completed on 06/25/2015.

**Example R4b:** Actions: Settings were issued on 6/02/2015 to enable out-of-step blocking on the existing microprocessor-based relay to prevent tripping in response to stable power swings. The setting changes were applied to the relay on 6/25/2015. CAP was completed on 06/25/2015.

The following is an example of actions taken to complete a CAP for a relay responding to a stable power swing that required the addition of an electromechanical power swing blocking relay.

**Example R4c:** Actions: A project for the addition of an electromechanical power swing blocking relay to supervise the Zone 2 impedance relay was initiated on 6/5/2015 to prevent tripping in response to stable power swings. The relay installation was completed on 9/25/2015. CAP was completed on 9/25/2015.

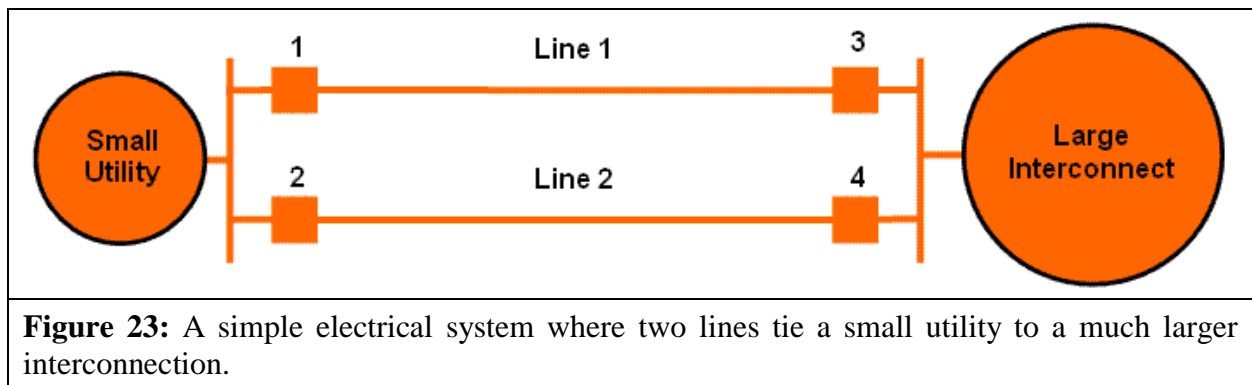
The following is an example of actions taken to complete a CAP with a timetable that required updating for the replacement of the relay.

**Example R4d:** Actions: A project for the replacement of the impedance relays at both terminals of line X with line current differential relays was initiated on 6/5/2015 to prevent tripping in response to stable power swings. The completion of the project was postponed due to line outage rescheduling from 11/15/2015 to 3/15/2016. Following the timetable change, the impedance relay replacement was completed on 3/18/2016. CAP was completed on 3/18/2016.

The CAP is complete when all the documented actions to remedy the specific problem (i.e., unnecessary tripping during stable power swings) are completed.

### Justification for Including Unstable Power Swings in the Requirements

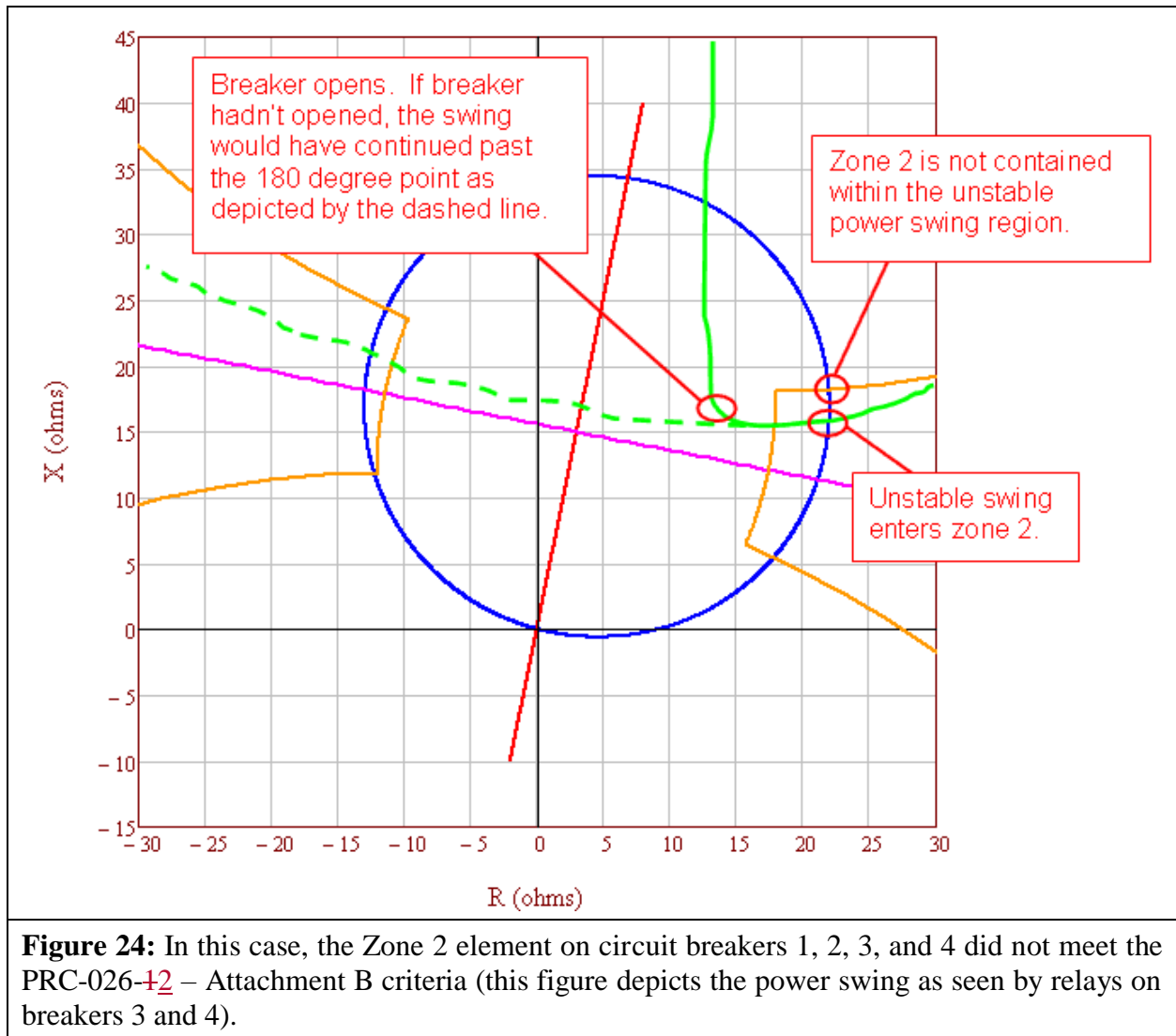
Protection Systems that are applicable to the Standard and must be secure for a stable power swing condition (i.e., meets PRC-026-1~~2~~ – Attachment B criteria) are identified based on Elements that are susceptible to both stable and unstable power swings. This section provides an example of why Elements that trip in response to unstable power swings (in addition to stable power swings) are identified and that their load-responsive protective relays need to be evaluated under PRC-026-1~~2~~ – Attachment B criteria.



**Figure 23:** A simple electrical system where two lines tie a small utility to a much larger interconnection.

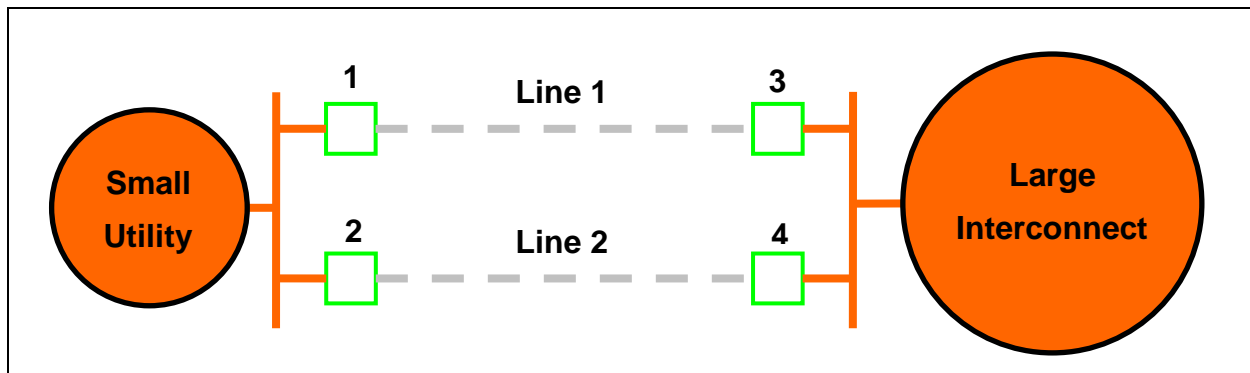
In Figure 23 the relays at circuit breakers 1, 2, 3, and 4 are equipped with a typical overreaching Zone 2 pilot system, using a Directional Comparison Blocking (DCB) scheme. Internal faults (or power swings) will result in instantaneous tripping of the Zone 2 relays if the measured fault or power swing impedance falls within the zone 2 operating characteristic. These lines will trip on

pilot Zone 2 for out-of-step conditions if the power swing impedance characteristic enters into Zone 2. All breakers are rated for out-of-phase switching.



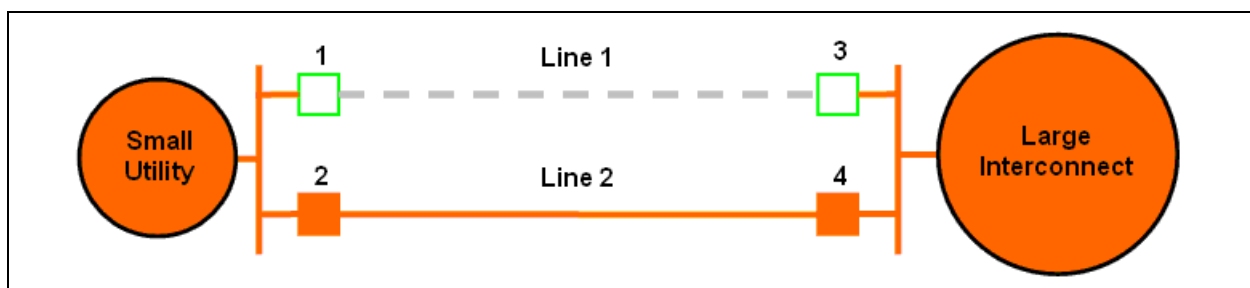
**Figure 24:** In this case, the Zone 2 element on circuit breakers 1, 2, 3, and 4 did not meet the PRC-026-12 – Attachment B criteria (this figure depicts the power swing as seen by relays on breakers 3 and 4).

In Figure 24, a large disturbance occurs within the small utility and its system goes out-of-step with the large interconnect. The small utility is importing power at the time of the disturbance. The actual power swing, as shown by the solid green line, enters the Zone 2 relay characteristic on the terminals of Lines 1, 2, 3, and 4 causing both lines to trip as shown in Figure 25.



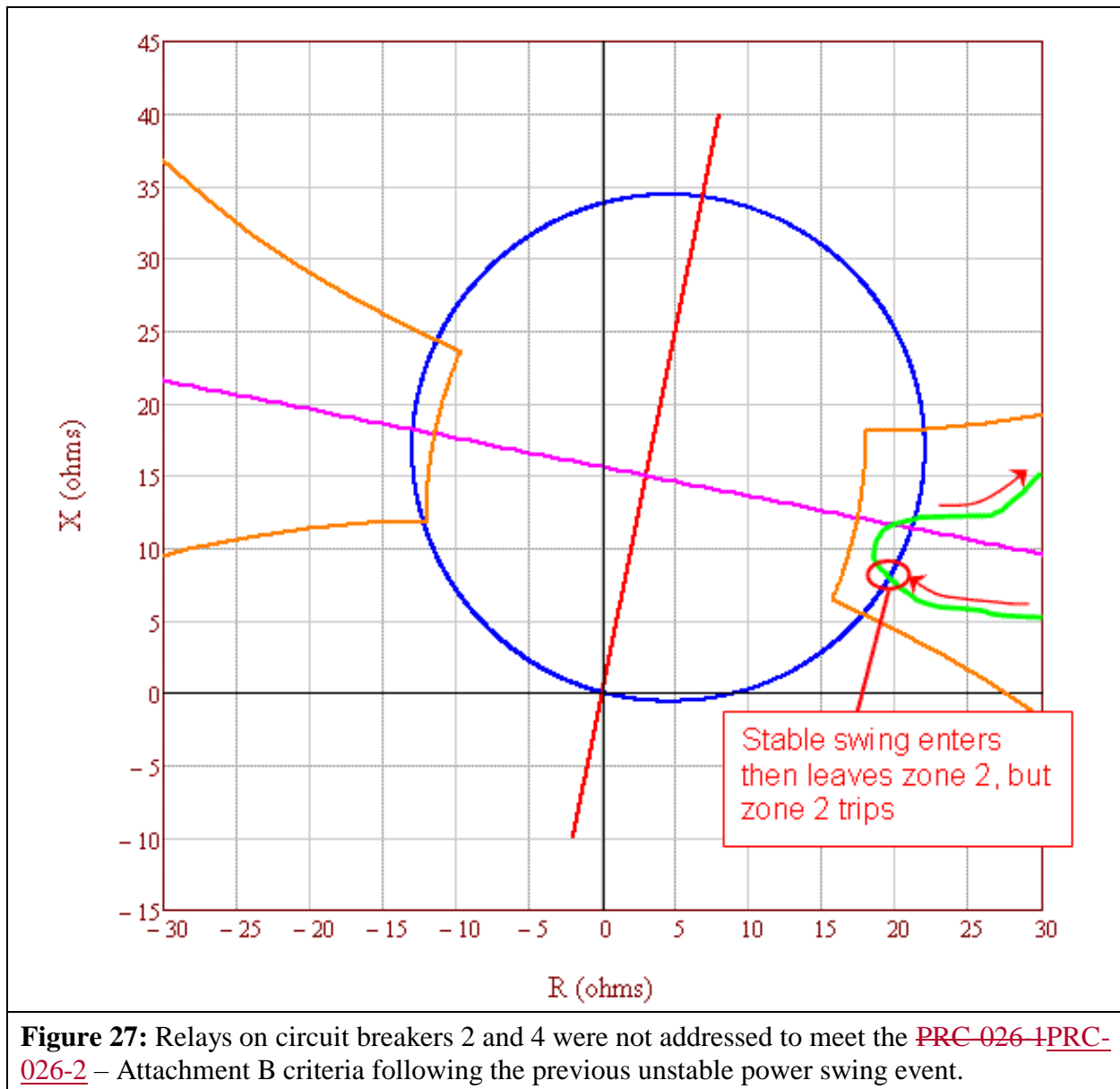
**Figure 25:** Islanding of the small utility due to Lines 1 and 2 tripping in response to an unstable power swing.

In Figure 25, the relays at circuit breakers 1, 2, 3, and 4 have correctly tripped due to the unstable power swing (shown by the dashed green line in Figure 24), de-energizing Lines 1 and 2, and creating an island between the small utility and the big interconnect. The small utility shed 500 MW of load on underfrequency and maintained a load to generation balance.

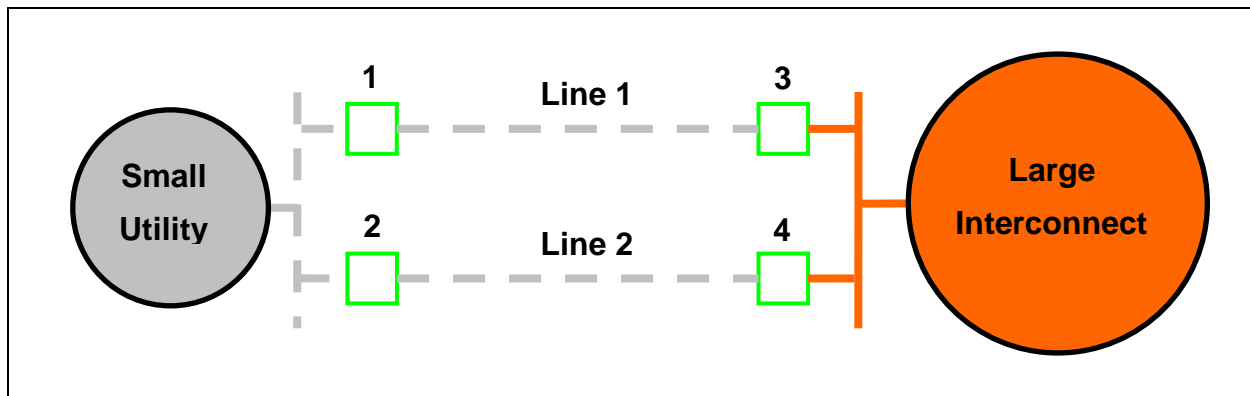


**Figure 26:** Line 1 is out-of-service for maintenance, Line 2 is loaded beyond its normal rating (but within its emergency rating).

Subsequent to the correct tripping of Lines 1 and 2 for the unstable power swing in Figure 25, another system disturbance occurs while the system is operating with Line 1 out-of-service for maintenance. The disturbance causes a stable power swing on Line 2, which challenges the relays at circuit breakers 2 and 4 as shown in Figure 27.



If the relays on circuit breakers 2 and 4 were not addressed under the Requirements for the previous unstable power swing condition, the relays would trip in response to the stable power swing, which would result in unnecessary system separation, load shedding, and possibly cascading or blackout.



**Figure 28:** Possible blackout of the small utility.

If the relays that tripped in response to the previous unstable power swing condition in Figure 24 were addressed under the Requirements to meet PRC-026-~~12~~ - Attachment B criteria, the unnecessary tripping of the relays for the stable power swing shown in Figure 28 would have been averted, and the possible blackout of the small utility would have been avoided.

## Rationale

During development of this standard, text boxes were embedded within the standard to explain the rationale for various parts of the standard. Upon BOT approval, the text from the rationale text boxes was moved to this section.

### Rationale for R1

The Planning Coordinator has a wide-area view and is in the position to identify generator, transformer, and transmission line BES Elements which meet the criteria, if any. The criteria-based approach is consistent with the NERC System Protection and Control Subcommittee (SPCS) technical document *Protection System Response to Power Swings*, August 2013 (“PSRPS Report”),<sup>31</sup> which recommends a focused approach to determine an at-risk BES Element. See the Guidelines and Technical Basis for a detailed discussion of the criteria.

### Rationale for R2

The Generator Owner and Transmission Owner are in a position to determine whether their load-responsive protective relays meet the PRC-026-~~12~~ – Attachment B criteria. Generator, transformer, and transmission line BES Elements are identified by the Planning Coordinator in Requirement R1 and by the Generator Owner and Transmission Owner following an actual event where the Generator Owner and Transmission Owner became aware (i.e., through an event

<sup>31</sup> NERC System Protection and Control Subcommittee, *Protection System Response to Power Swings*, August 2013:  
[http://www.nerc.com/comm/PC/System%20Protection%20and%20Control%20Subcommittee%20SPCS%2020/SPCS%20Power%20Swing%20Report\\_Final\\_20131015.pdf](http://www.nerc.com/comm/PC/System%20Protection%20and%20Control%20Subcommittee%20SPCS%2020/SPCS%20Power%20Swing%20Report_Final_20131015.pdf)

analysis or Protection System review) tripping was due to a stable or unstable power swing. A period of 12 calendar months allows sufficient time for the entity to conduct the evaluation.

### **Rationale for R3**

To meet the reliability purpose of the standard, a CAP is necessary to ensure the entity's Protection System meets the PRC-026-~~12~~ – Attachment B criteria (1<sup>st</sup> bullet) so that protective relays are expected to not trip in response to stable power swings. A CAP may also be developed to modify the Protection System for exclusion under PRC-026-~~12~~ – Attachment A (2<sup>nd</sup> bullet). Such an exclusion will allow the Protection System to be exempt from the Requirement for future events. The phrase, "...while maintaining dependable fault detection and dependable out-of-step tripping..." in Requirement R3 describes that the entity is to comply with this standard, while achieving their desired protection goals. Refer to the Guidelines and Technical Basis, Introduction, for more information.

### **Rationale for R4**

Implementation of the CAP must accomplish all identified actions to be complete to achieve the desired reliability goal. During the course of implementing a CAP, updates may be necessary for a variety of reasons such as new information, scheduling conflicts, or resource issues. Documenting CAP changes and completion of activities provides measurable progress and confirmation of completion.

### **Rationale for Attachment B (Criterion A)**

The PRC-026-~~12~~ – Attachment B, Criterion A provides a basis for determining if the relays are expected to not trip for a stable power swing having a system separation angle of up to 120 degrees with the sending-end and receiving-end voltages varying from 0.7 to 1.0 per unit (See Guidelines and Technical Basis).

## Exhibit A-9

Definition of System Operating Limit  
(Clean and Redline to Last Approved)



# NERC Glossary Definition: System Operating Limit

## Term: "System Operating Limit"

### Definition:

#### Redline

All Facility Ratings, System Voltage Limits, and stability limits, applicable to ~~The value (such as MW, Mvar, amperes, frequency or volts) that satisfies the most limiting of the prescribed operating criteria for a~~ specified system configurations, used in Bulk Electric System operations for monitoring and assessing pre- and post-Contingency operating states. ~~to ensure operation within acceptable reliability criteria. System Operating Limits are based upon certain operating criteria. These include, but are not limited to:~~

- ~~• Facility Ratings (applicable pre and post Contingency Equipment Ratings or Facility Ratings)~~
- ~~• transient stability ratings (applicable pre and post Contingency stability limits)~~
- ~~• voltage stability ratings (applicable pre and post Contingency voltage stability)~~
- ~~• system voltage limits (applicable pre and post Contingency voltage limits)~~

#### Clean

All Facility Ratings, System Voltage Limits, and stability limits, applicable to specified System configurations, used in Bulk Electric System operations for monitoring and assessing pre- and post-Contingency operating states.

## Exhibit A-10

### Definition of System Voltage Limit (Clean)

# Proposed Definition of “System Voltage Limit”

**Term: “System Voltage Limit”**

**Definition:**

The maximum and minimum steady-state voltage limits (both normal and emergency) that provide for acceptable System performance.

## Exhibit B

### Implementation Plan

# Implementation Plan

## Project 2015-09 Establish and Communicate System Operating Limits

### Applicable Standard(s) and Definitions

- FAC-011-4 - System Operating Limits Methodology for the Operations Horizon
- FAC-014-3 - Establish and Communicate System Operating Limits
- FAC-003-5 - Transmission Vegetation Management
- PRC-002-3 - Disturbance Monitoring and Reporting Requirements
- PRC-023-5 - Transmission Relay Loadability
- PRC-026-2 - Relay Performance During Stable Power Swings
- TOP-001-6 - Transmission Operations
- IRO-008-3 - Reliability Coordinator Operational Analyses and Real-time Assessments
- Definition of System Voltage Limit in the Glossary of Terms Used in NERC Reliability Standards (“NERC Glossary”)
- Definition of System Operating Limit in the NERC Glossary

### Requested Retirement(s)

- FAC-010-3 - System Operating Limits Methodology for the Planning Horizon
- FAC-011-3 - System Operating Limits Methodology for the Operations Horizon
- FAC-014-2 - Establish and Communicate System Operating Limits
- FAC-003-4 - Transmission Vegetation Management
- PRC-002-2 - Disturbance Monitoring and Reporting Requirements
- PRC-023-4 - Transmission Relay Loadability
- PRC-026-1 - Relay Performance During Stable Power Swings
- TOP-001-5 - Transmission Operations
- IRO-008-2 - Reliability Coordinator Operational Analyses and Real-time Assessments
- Currently-effective definition of System Operating Limit

### Effective Date

The effective date for proposed Reliability Standards FAC-011-4, FAC-014-3, FAC-003-5, PRC-002-3, PRC-023-5, PRC-026-2, TOP-001-6, IRO-008-3 and the NERC Glossary terms “System Voltage Limit” and “System Operating Limit” is provided below:

Where approval by an applicable governmental authority is required, Reliability Standards FAC-011-4, FAC-014-3, FAC-003-5, PRC-002-3, PRC-023-5, PRC-026-2, TOP-001-6, IRO-008-3 and the NERC Glossary terms “System Voltage Limit” and “System Operating Limit” shall become effective the first day of the first calendar quarter that is twenty-four (24) calendar months after the effective date of

the applicable governmental authority's order approving the standards and terms, or as otherwise provided for by the applicable governmental authority.

Where approval by an applicable governmental authority is not required, Reliability Standards FAC-011-4, FAC-014-3, FAC-003-5, PRC-002-3, PRC-023-5, PRC-026-2, TOP-001-6, IRO-008-3 and the NERC Glossary terms "System Voltage Limit" and "System Operating Limit" shall become effective on the first day of the first calendar quarter that is twenty-four (24) calendar months after the date the standards and terms are adopted by the NERC Board of Trustees, or as otherwise provided for in that jurisdiction.

## **Retirement Date**

### **Currently-Effective NERC Reliability Standards**

Reliability Standards FAC-010-3, FAC-011-3, FAC-014-2, FAC-003-4, PRC-002-2, PRC-023-4, and PRC-026-1, TOP-001-5, IRO-008-3 shall be retired immediately prior to the effective date of the proposed Reliability Standards FAC-011-4, FAC-014-3, FAC-003-5, PRC-002-3, PRC-023-5, PRC-026-2, and the current definition of System Operating Limit.

### **Prior Implementation Plans**

Unless otherwise specified herein, the elements of the Implementation Plans for FAC-003-4, PRC-002-2, PRC-023-4, and PRC-026-1 are incorporated herein by reference and shall remain applicable to FAC-003-5, PRC-002-3, PRC-023-5, and PRC-026-2. The following is a description of the elements from prior implementation plans that remain applicable without modification:

- *FAC-003-5: Newly Designated Lines time period*
  - A line operated below 200kV and identified in the Applicability under 4.2 becomes subject to this standard the later of: 1) 12 months after the date the Planning Coordinator, Transmission Planner or WECC identified the line in Applicability under 4.2, or 2) January 1 of the planning year when the line is forecasted to be identified in Applicability under 4.2. A line operating below 200kV identified in Applicability under 4.2 may be removed from that designation due to system improvements, changes in generation, changes in loads, or changes in studies, and analysis of the network.
- *PRC-002-3 Requirements R2, R3, R4, R6, R7, R8, R9, R10, R11: Initial Date:*
  - Entities shall be at least 50 percent compliant within four (4) years of the effective date of PRC-002-2 and fully compliant within six (6) years of the effective date.
  - Entities that own only one (1) identified BES bus, BES Element, or generating unit shall be fully compliant within six (6) years of the effective date of PRC-002-2.
- *PRC-002-3 Requirements R2, R3, R4, R6, R7, R8, R9, R10, R11: Time Period to Address New Designations:*
  - Entities shall be 100 percent compliant with new BES Elements identified in Requirement R1 or R5 within three (3) years following the notification by the Transmission Operator or the Reliability Coordinator.

- *PRC-023-4: Time Period to address new designations is retained:*
  - Each Transmission Owner, Generator Owner, and Distribution Provider with circuits identified by the Planning Coordinator pursuant to Requirement R6 shall meet R1 on the later of the first day of the first calendar quarter 39 months following notification by the Planning Coordinator of a circuit's inclusion on a list of circuits per application of Attachment B, or the first day of the first calendar year in which any criterion in Attachment B applies, unless the Planning Coordinator removes the circuit from the list before the applicable effective date.

### **Additional Provisions**

The following are additional implementation provisions to address revisions in the Reliability Standards that require new or different actions by the same or different entities than the prior version of the Reliability Standards required.

- *PRC-002-3, Requirement R5*
  - Reliability Coordinators in the Eastern Interconnect shall be fully compliant with Requirement R5 within six (6) months of the effective date of PRC-002-3.
- *PRC-023-5*
  - Each Planning Coordinator shall conduct its first assessment under PRC-023-5 within the next calendar year after the effective date or within 15 months of their last assessment under PRC-023-4, whichever occurs first.
- *PRC-026-2*
  - Each Planning Coordinator shall complete Requirement R1 within the calendar year of the effective date unless they have already completed Requirement R1 under PRC-026-1 for that calendar year, in which case they must complete Requirement R1 within the following year.
- *FAC-014-3, Requirement R6*
  - Requirement R6 shall be implemented by the Planning Coordinator or Transmission Planner following the effective date of FAC-014-3 when it begins its next cycle for conducting the studies to support its Planning Assessment.
- *FAC-014-3, Requirements R7 and R8*
  - Each Planning Coordinator and Transmission Planner shall comply with Requirements R7 and R8 within one year of the effective date of the standard.

Exhibit C-1

Technical Rationale  
FAC-011-4



# Technical Rationale for Reliability Standard FAC-011-4

April 2021

## FAC-011-4 – System Operating Limits Methodology for the Operations Horizon

### Requirement R1

- R1.** Each Reliability Coordinator shall have a documented methodology for establishing SOLs (i.e., SOL methodology) within its Reliability Coordinator Area.

#### Rationale R1

The three subparts in Requirement R1 in currently-effective Reliability Standard FAC-011-3 are either not necessary for reliability, or they are addressed through other mechanisms in FAC-011-4 and therefore are not included as part of Requirement R1.

Requirement R1 Part 1.1 in currently-effective FAC-011-3 requires the SOL methodology “be applicable for developing System Operating Limits (SOLs) used in the operations horizon.” The revised Requirement R1 is applicable to the Operations Planning Time Horizon. Accordingly, there is no reliability-related need to have a requirement specifying that the Reliability Coordinator’s (RC’s) SOL methodology is applicable for developing SOLs used in the operations horizon. Additionally, the purpose of the standard references SOLs used in the reliable operation of the BES.

Requirement R1 Part 1.2 in currently-effective FAC-011-3 requires the SOL methodology to “state that SOLs shall not exceed associated Facility Ratings.” Facility Ratings to be used in operations as SOLs are addressed through FAC-011-4 Requirement R2 and therefore, is not addressed as a subpart of R1.

Requirement R1 Part 1.3 in currently-effective FAC-011-3 requires the SOL methodology to “include a description of how to identify the subset of SOLs that qualify as IROLs.” This language is preserved in Requirement R7.

### Requirement R2

- R2.** Each Reliability Coordinator shall include in its SOL methodology the method for Transmission Operators to determine which owner-provided Facility Ratings are to be used in operations such that the Transmission Operator and its Reliability Coordinator use common Facility Ratings.

#### Rationale R2

The reliability objectives of Requirement R2 are 1) to ensure the owner-provided Facility Ratings that are selected for use in operations are determined in accordance with the RC’s SOL methodology, and 2) to ensure the consistent use of applicable Facility Ratings between RCs and their Transmission

Operators (TOP). For example, if a Transmission Owner (TO) provides three levels of Facility Ratings pursuant to Reliability Standard FAC-008-3, and another TO provides five levels of ratings, the RC will establish the method for the TOPs to determine which of those Facility Ratings will be utilized in common with the TOP and the RC for monitoring and assessments.

The intent of Requirement R2 is not to change, limit, or modify Facility Ratings determined by the equipment owner. The equipment owner is still the functional entity responsible for determining Facility Ratings per FAC-008. The intent is to use those owner-provided Facility Ratings in a consistent manner between RCs and their TOPs during operations.

### **Requirement R3**

- R3.** Each Reliability Coordinator shall include in its SOL methodology the method for Transmission Operators to determine the System Voltage Limits to be used in operations. The method shall:
- 3.1.** Require that each BES bus/station have an associated System Voltage Limits, unless its SOL methodology specifically allows the exclusion of BES buses/stations from the requirement to have an associated System Voltage Limit;
  - 3.2.** Require that System Voltage Limits respect voltage-based Facility Ratings;
  - 3.3.** Require that System Voltage Limits are greater than or equal to in-service BES relay settings for under-voltage load shedding systems and Undervoltage Load Shedding Programs;
  - 3.4.** Identify the minimum allowable System Voltage Limit;
  - 3.5.** Define the method for determining common System Voltage Limits between the Reliability Coordinator and its Transmission Operators, between adjacent Transmission Operators, and between adjacent Reliability Coordinators within an Interconnection;

### **Rationale R3**

System Voltage Limits (SVLs) are intended to provide reliable pre- and post-contingency System performance for operations within each RC Area. The proposed definition of System Voltage Limits includes normal and emergency voltage limits, and can also include time-based voltage limits, depending on what the RC requires. It is expected that the RC would require a set of System Voltage Limits to cover the entire BES system within its RC Area for voltage-based Facility Ratings, voltage instability, voltage collapse and misactuation of relay elements.

Both maximum and minimum limits are required. Maximum limits tend to be associated with equipment/facility limitations. Minimum limits are often used to prevent phenomena associated with minimum voltages such as system instability, voltage collapse, and potential misactuation of relay elements. Identifying the set of “System Voltage Limits”, both maximum and minimum, assures that all voltage limits associated with a particular bus or station, or the equipment connected to it, have been considered and the most limiting are used. The terms maximum and minimum are used through the standard, rationale and definitions with regard to voltage limits however it is common in industry to use the terms low, lowest, high and highest as synonyms for maximum and minimum and such usage is acceptable.

While all BES buses/stations have equipment related voltage ratings, there may be reasons that certain buses/stations do not require a System Voltage Limit. Part 3.1 allows RCs to identify certain buses/stations that may be excluded from having an associated System Voltage Limit. The identification of such buses/stations could be documented by citing the type of buses/stations (based on voltage level or area of the System) as opposed to a more detailed list of individual buses/stations which are exempt.

Buses or stations may not require System Voltage Limits when the voltage at the station has no material impact on System performance and associated SOLs. For example, System Voltage Limits at neighboring/nearby stations may be sufficient to protect the facilities from maximum voltage, and the System from instability, voltage collapse, and misactuation of relay elements.

Part 3.5 requires that the SOL methodology define a method for determining common System Voltage Limits between RCs and TOPs. RC and TOPs may independently identify System Voltage Limits which if not coordinated could create reliability issues. An example could be where one TOP A chooses very wide System Voltage Limits on its equipment but TOP B could have much tighter System Voltage Limits even within the same substation. TOP A may operate equipment that are within its System Voltage Limits but cause an exceedance of TOP B's equipment. Coordinating the System Voltage Limits in these circumstances can prevent unnecessary exceedances of the System Voltage Limits.

Part 3.2 provides that in establishing System Voltage Limits, the SOL methodology shall respect any voltage-based Facility Ratings established by the Generation Owner or TO under FAC-008. Recognizing that voltage limits are difficult to reflect by facility, the System Voltage Limits provided for stations/buses should reflect any voltage-based Facility Ratings for facilities that terminate at, or are adjacent to the stations/buses with System Voltage Limits.

FERC Order No. 818 issued November 19, 2015, states that Undervoltage Load Shedding Programs (UVLS) should not be triggered for an N-1 Contingency. As such, under Part 3.3, the SOL methodology shall ensure System Voltage Limits are not set at values less than UVLS settings to avoid UVLS operation following N-1 Contingencies.

#### **Requirement R4**

- R4.** Each Reliability Coordinator shall include in its SOL methodology the method for determining the stability limits to be used in operations. The method shall:
  - 4.1.** Specify stability performance criteria, including any margins applied. The criteria shall, at a minimum, include the following:
    - 4.1.1.** steady-state voltage stability;
    - 4.1.2.** transient voltage response;
    - 4.1.3.** angular stability; and
    - 4.1.4.** System damping.

- 4.2. Require that stability limits are established to meet the criteria specified in Part 4.1 for the Contingencies identified in Requirement R5 applicable to the establishment of stability limits that are expected to produce more severe System impacts on its portion of the BES.
- 4.3. Describe how the Reliability Coordinator establishes stability limits when there is an impact to more than one Transmission Operator in its Reliability Coordinator Area or other Reliability Coordinator Areas.
- 4.4. Describe how stability limits are determined, considering levels of transfers, Load and generation dispatch, and System conditions including any changes to System topology such as Facility outages;
- 4.5. Describe the level of detail that is required for the study model(s); including the extent of the Reliability Coordinator Area, as well as the critical modeling details from other Reliability Coordinator Areas, necessary to determine different types of stability limits.
- 4.6. Describe the allowed uses of Remedial Action Schemes and other automatic post-Contingency mitigation actions in establishing stability limits used in operations.
- 4.7. State that the use of underfrequency load shedding (UFLS) programs and Undervoltage Load Shedding Programs are not allowed in the establishment of stability limits.

#### **Rationale R4**

Reliability Standard FAC-011-3 currently requires the System to demonstrate transient, dynamic, and voltage stability for both pre- and post-contingent states, but does not provide specifics. By requiring specific stability criteria within the SOL methodology, the standard is improved and provides greater clarity and uniformity on practices across the industry. The set of commonly used stability criteria specified in Requirement R4 Part 4.1 is based upon information provided by standard drafting team members and observers, including many RCs and TOPs. Industry input from areas with significant experience managing stability issues led to the inclusion of System damping.

Also included in Part 4.1 is language requiring the SOL methodology to include descriptions of how margins are applied. This language was added to explicitly capture the practices in use by RCs for off-line or on-line calculated stability limits, including any margin used in the application of the stability limits. It is left to the RC what type of margin to use (a percentage of the limit or a fixed MW value, for example), if it uses one at all.

Requirement R4 Part 4.2 provides the link to the Contingencies which must be respected in operations. Many stability tools will consider a subset of contingencies that are applicable to the area in study and are expected to produce more severe System impacts rather than every single potential contingency to set the limits conservatively while minimizing the time it takes to complete the solution, which is reflected in the phrase “applicable to the establishment of stability limits that are expected to produce more severe System impacts on its portion of the BES”. In response to industry comments, Contingency specifications were moved to a separate requirement.

Requirement R4 Part 4.3 was introduced to preclude ambiguity in the resolution of stability limits when multiple TOPs within an RC's footprint are impacted. For example, the SOL methodology could describe which TOP or RC has the responsibility to determine stability SOLs impacting multiple TOPs, and could also determine how to choose between stability limits derived by multiple TOPs for the same stability limit exceedance. Additionally, Requirement R4 Part 4.3 addresses when there is an impact to other Reliability Coordinator Areas.

Requirement R4 Parts 4.4, 4.5 and 4.6 require that the SOL methodology provide a description of the key parameters that must be considered and monitored when performing analyses to determine the stability limits. The intent of these parts is to help ensure that the SOL methodology provides guidance such that the process/method used by the RC to determine stability limits may be repeated, successfully, by anyone reading the SOL methodology. For example, the SOL methodology could state that stability limits will be determined for any combination of all facilities in and single facility out conditions, for all valid transfer conditions for the highest allowable thermal transfer condition (i.e. winter ratings), plus a flow margin of 10 percent, to account for potential emergency transfer conditions. This level of detail would allow TOPs and other entities to consistently duplicate results from study to study. Part 4.5 combines FAC-011-3 Requirement R3 Parts R3.1 and R3.4 into a single part while providing flexibility to the extent of the RC Area (including other RC Areas) that must be modeled to reflect the varying needs for different types of stability limits (e.g. local single unit stability up to wide area or inter area instability). By recognizing that some types of localized stability issues do not require the modeling of the entire Reliability Coordinator Area to establish a stability limit, this revision aligns with and promotes the ability to monitor these localized areas with real time stability analysis tools.

Requirement 4 Part 4.4 is specifically intended to address the need for the SOL methodology to identify the method for ensuring stability limits are "valid" (i.e. provide stable operations pre- and post-Contingency) for the Operational Planning Analysis (OPA) and Real-time Assessments (RTA) for which they will be used. Since stability limits may vary based on the system topology, load, generation dispatch, etc., and the current definitions for OPA and RTA include "An evaluation of ... system conditions to assess anticipated (pre-Contingency) and potential (post-Contingency) conditions for ...operations", the stability limits used in OPA/RTA should be "valid" for those system conditions.

As described within PRC-006-2 in alignment with FERC Order No. 763, underfrequency load shedding (UFLS) programs are designed "to arrest declining frequency, assist recovery of frequency following underfrequency events and provide last resort system preservation measures." In the establishment of stability limits under Requirement R4 Part 4.7, UFLS programs or UVLS Programs are expressly prohibited from being considered as an acceptable post-Contingency mitigation action in order to preserve the intended availability of UFLS programs and UVLS Programs as measures of "last resort system preservation".

## **Requirement R5**

**R5.** Each Reliability Coordinator shall identify in its SOL methodology the set of Contingency events for use in determining stability limits and the set of Contingency events for use in performing

Operational Planning Analysis (OPAs) and Real-time Assessments (RTAs). The SOL methodology for each set shall:

**5.1.** Specify the following single Contingency events:

**5.1.1.** Loss of any of the following either by single phase to ground or three phase Fault (whichever is more severe) with Normal Clearing, or without a Fault:

- generator;
- transmission circuit;
- transformer;
- shunt device; or
- single pole block in a monopolar or bipolar high voltage direct current system.

**5.2.** Specify additional single or multiple Contingency events or types of Contingency events, if any.

**5.3.** Describe the method(s) for identifying which, if any, of the Contingency events provided by the Planning Coordinator or Transmission Planner in accordance with FAC-014-3, Requirement R7, to use in determining stability limits.

**Rationale R5**

Requirement R5 combines both the requirements for single Contingencies (formerly in Requirement R2 Part 2.2 of FAC-011-3) and for multiple Contingencies (formerly in Requirement R3 Part 3.3 of FAC-011-3) for ease of interpretation.

Furthermore, Requirement R5 continues to maintain the flexibility that existed in FAC-011-3 Requirement R2 Part 2.2 and Requirement R3 Part 3.3 for each RC to determine which additional single and multiple Contingencies to respect given the uniqueness of their system. Through both the feedback received as a result of the July 2016 informal posting and the May 2016 technical conference it was evident that both the drafting team and industry agree that sufficient flexibility is required for each RC to determine its own methodology for addressing Contingencies other than single Contingencies.

Requirement R5 mandates that the RC specify which types of Contingencies (both single and multiple) are used for determining stability limits as well as those used in the evaluation of post-Contingency state in OPAs and RTAs (thermal and voltage). The SOL methodology is the best place to communicate which Contingencies the RC is respecting in their footprint such that all TOPs and any neighboring RCs understand one another's internal and interconnection-related reliability objectives.

Requirement R5 Part 5.1.1 identifies the types of single Contingency events that, at a minimum, must be used for stability limit analysis and for performing OPAs and RTAs. However, other types of single Contingency events, such as inadvertent breaker operation and bus faults, may be considered if the probability of such an event is relevant. These Contingencies, if any, must be specified in the RC's methodology as per Requirement R5 Part 5.2.



Requirement R5 Part 5.3 compliments the proposed Requirement R8 in FAC-014-3 by ensuring the RC's methodology describes how the Contingency event information from the Planning Coordinator is used in deriving stability limits used in operations.

Requirement R5 establishes the contingency events for use in determining stability limits, in performing Operational Planning Analysis (OPAs), and in performing Real-Time Assessments (RTAs). The standard requirement is not meant to imply that all TOPs within the RC footprint must use that identical list spanning the entire RC region but may use a reduced list that at least covers the area they are responsible for the most limiting Contingencies.

### **Requirement R6**

**R6.** Each Reliability Coordinator shall include the following performance framework in its SOL methodology to determine SOL exceedances when performing Real-time monitoring, Real-time Assessments, and Operational Planning Analyses:

**6.1.** System performance for no Contingencies demonstrates the following:

**6.1.1.** Steady state flow through Facilities are within Normal Ratings; however, Emergency Ratings may be used when System adjustments to return the flow within its Normal Rating could be executed and completed within the specified time duration of those Emergency Ratings.

**6.1.2.** Steady state voltages are within normal System Voltage Limits; however, emergency System Voltage Limits may be used when System adjustments to return the voltage within its normal System Voltage Limits could be executed and completed within the specified time duration of those emergency System Voltage Limits.

**6.1.3.** Predetermined stability limits are not exceeded.

**6.1.4.** Instability, Cascading or uncontrolled separation that adversely impact the reliability of the Bulk Electric System does not occur.<sup>1</sup>

**6.2.** System performance for the single Contingencies listed in Part 5.1 demonstrates the following:

**6.2.1.** Steady State post-Contingency flow through Facilities within applicable Emergency Ratings. Steady state post-Contingency flow through a Facility must not be above the Facility's highest Emergency Rating.

**6.2.2.** Steady state post-Contingency voltages are within emergency System Voltage Limits.

**6.2.3.** The stability performance criteria defined in Reliability Coordinator's SOL methodology are met.

---

<sup>1</sup> Stability evaluations and assessments of instability, Cascading, and uncontrolled separation can be performed using real-time stability assessments, predetermined stability limits or other offline analysis techniques.

- 6.2.4.** Instability, Cascading or uncontrolled separation that adversely impact the reliability of the Bulk Electric System does not occur<sup>1</sup>.
- 6.3.** System performance for applicable Contingencies identified in Part 5.2 demonstrates that: instability, Cascading, or uncontrolled separation that adversely impact the reliability of the Bulk Electric System does not occur.
- 6.4.** In determining the System’s response to any Contingency identified in Requirement R5, planned manual load shedding is acceptable only after all other available System adjustments have been made.

### **Rationale R6**

Requirement R6 addresses BES performance criteria, which is addressed in the currently effective FAC-011-3 Requirement R2 Parts 2.1 and 2.2. The proposed requirement has some differences in the manner in which the performance criteria are addressed and in the level of detail reflected in the requirement when compared to the existing requirement. Those differences are discussed here.

Currently effective FAC-011-3 Requirement R2 states that the *“RC’s SOL methodology shall include a requirement that SOLs provide BES performance consistent with the following.”* The subsequent subparts to FAC-011-3 Requirement R2 further describe pre-Contingency performance criteria (in Requirement R2 Part 2.1), the post-Contingency performance criteria (in Requirement R2 Part 2.2), and describe other rules related to the establishment of SOLs in the remaining subparts. The language in Requirement R2 indicates that the SOLs established in accordance with Requirement R2 are expected to “provide” a level of pre- and post-Contingency reliability described in the subparts of Requirement R2. Accordingly, the assessments of the pre-Contingency state and the post-Contingency state are expected to be performed as part of the SOL establishment process, yielding a set of SOLs that “provide” for meeting the performance criteria denoted in FAC-011-3 Requirement R2 and its subparts.

Pursuant to the construct in the currently-effective TOP/IRO Reliability Standards, the pre- and post-Contingency states are assessed on an ongoing basis as part of Operational Planning Analyses (OPAs) and Real-time Assessments (RTAs). Any SOL exceedances that are observed are required to be mitigated per the respective Operating Plans. Under this construct, it is the OPA, the RTA, and the implementation of Operating Plans that “provide” for reliable pre- and post-Contingency operations through the application of the minimum performance criteria specified in FAC-011-4 requirement R6 and subparts. Under this construct, the assessments of the pre-Contingency state and the post-Contingency state are expected to be performed as part of the OPA and RTA for Facility Rating and System Voltage Limits. Stability limits are either established prior to the OPA/RTA or established and assessed during the OPA and RTA.

Requirement R6 works together with proposed TOP-001-5 Requirement R25 and IRO-008-3 R7 to support reliable operations for pre- and post-Contingency operating states. TOP-001 Requirement R25 states, *“Each Transmission Operator shall use the applicable RC’s SOL methodology when*



*determining SOL exceedances for Real-time Assessments, Real-time Monitoring, and Operational Planning Analysis.” IRO-008-3 Requirement R7 states, “Each Reliability Coordinator shall use its SOL methodology when determining SOL exceedances for Real-time Assessments, Real-time Monitoring, and Operational Planning Analysis.” The above noted requirements in TOP-001 and IRO-008 ensure that the performance framework identified in the SOL methodology is used to determine SOL exceedances consistently between the RC and its associated TOPs during Real-time Assessments, Real-time Monitoring, and Operational Planning Analysis.”*

FAC-011-4 Requirement R6 Parts 6.1.1 and 6.1.2 are intended to prescribe the appropriate use of Emergency Ratings and Emergency System Voltage Limits when actual (or OPA no Contingency) flows or voltages exceed Normal Ratings or fall outside normal System Voltage Limits, respectively.

The language in Part 6.1.1 reflects the concepts in Figure 1 of the Project 2014-03 Whitepaper (NERC SOL Whitepaper) with regard to Facility Rating performance. Part 6.1.1 states, *“Steady state flow through Facilities are within applicable Emergency Ratings, provided that System adjustments to return the flow within its Normal Rating can be executed and completed within the specified time duration of those Emergency Ratings.”* This is intended to allow, as an example, for the use of the 4-hour Emergency Rating and the 15-minute Emergency Rating consistent with the bullet descriptions in Figure 1. As is described in Figure 1, the use of the Emergency Ratings is governed by the amount of time it takes to execute the Operating Plan to mitigate the condition. The portion of Part 6.2.1 that states, *“Steady state post-Contingency flow through a Facility must not be above the Facility’s highest Emergency Rating”* is intended to specifically address the operating state highlighted in yellow in Figure 1. In this operating state, the System Operator may have insufficient time to implement post-Contingency mitigation actions (i.e., actions that are taken after the Contingency event occurs); therefore, pre-Contingency mitigation actions consistent with the Operating Plan must be taken as soon as possible to reduce the calculated post-Contingency flow. However, as noted in the NERC SOL Whitepaper, pre-Contingency load shed may not be necessary or appropriate when assessment identifies that the impact is localized.

Requirement 6 applies only to those contingencies specified by the Reliability Coordinator for monitoring in the Transmission Operators RTA and OPA. If the Transmission Operators monitors additional contingencies beyond the subset required by the Reliability Coordinator, they are not required to meet the performance metrics in Requirement 6. As an example, if a TOP chooses to monitor loss of an entire substation as a contingency within their contingency analysis this section does not require that system performance following that event must meet these performance requirements. If the loss of a substation was not a defined contingency in the RC’s SOL methodology, and no other defined contingency could cause loss of the entire substation, then the TOP could define what performance criteria, if any, to apply to this contingency. Said simply, R6 specifically applies only to the events and conditions described in R5.

# SOL Performance Summary

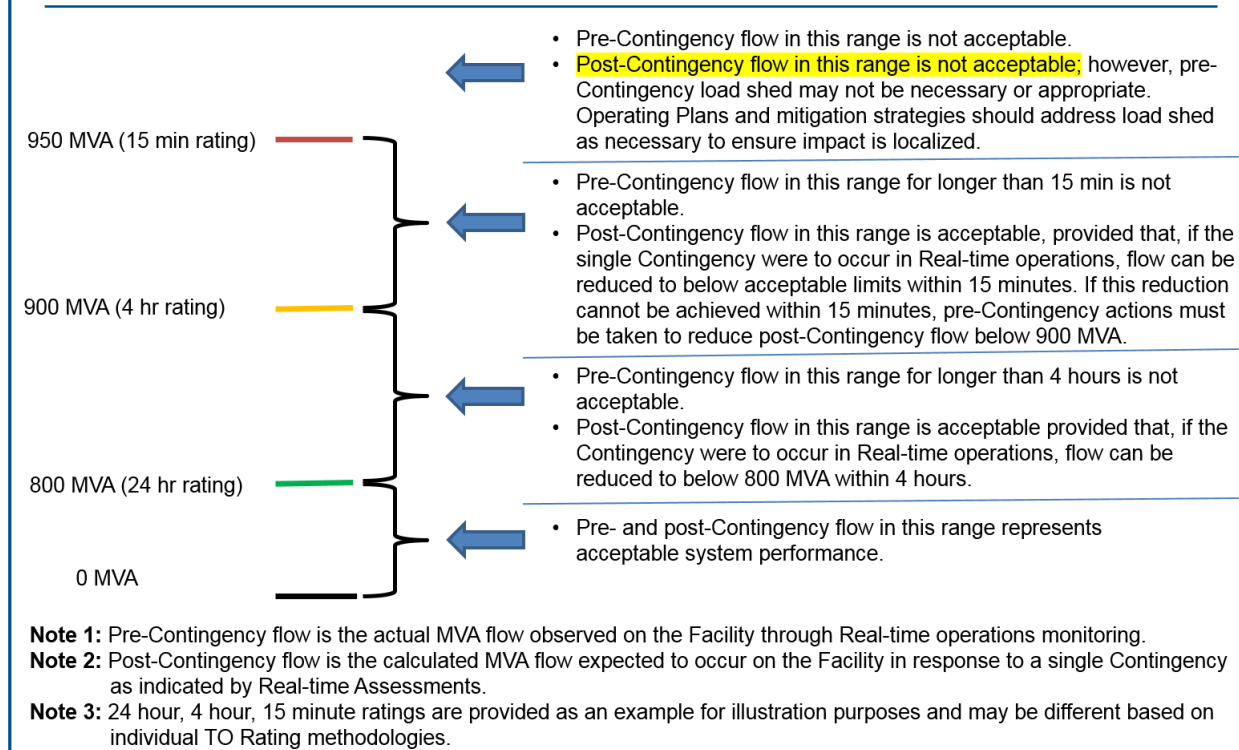


Figure 1 of the NERC SOL Whitepaper

The footnote referenced in Parts 6.1.4 and 6.2.3 states, “Stability evaluations and assessments of instability, Cascading, and uncontrolled separation can be performed using real-time stability assessments, predetermined stability limits or other offline analysis techniques.” This helps to provide clarity that there are multiple methods to assessing if System performance demonstrates that Instability, Cascading or uncontrolled separation that adversely impact the reliability of the Bulk Electric System does not occur. Some entities determine stability limits across a variety of operating conditions and apply the appropriate limit to the operating condition in the OPA, RTA and Real time monitoring. Other entities may utilize tools that run at the time of the study to assess for acceptable performance or determine stability limits at the time of the OPA or RTA. Others may yet utilize other offline analysis techniques.

Part 6.3 recognizes the potential for regional differences and is intended to describe the minimum performance criteria for Contingency events that are more severe than the single Contingency events listed in Requirement R5 Part 5.1.1 for OPAs and RTAs (i.e., Contingencies identified in Part 5.2). Per Part 6.3, if any of these more severe Contingency events were to occur, at a minimum the System is expected to remain stable, there should be no Cascading, and there should be no uncontrolled separation that adversely impact the reliability of the Bulk Electric System.

Part 6.4 maintains the concept identified in FAC-011-3 Requirement R2 Part 2.3.2 and intent of FERC Order No. 705, where FERC determined that load shedding shall only be utilized by system operators as a measure of last resort to prevent cascading failures. Part 6.4 clarifies that load shedding as a remedy in the operating plan should only be allowed **by the RC's methodology** after other options are exercised without regard for financial impact. The term "planned manual load shedding" refers to the inclusion of planned post-Contingency shedding of load either manually or by automated methods in an Operating Plan. **This Operation Plan is developed in response to SOL exceedances identified in its Operating Planning Analysis including for contingencies identified in Requirement R5 against the transmission system under study and would apply to the Operational Planning Analysis. While those plans guide an operator's response to an event in Real-time monitoring or a Real-time Assessment, Part 6.4 would not directly apply to the actions taken by the operator in real time.**

For clarity, the following examples of pre- or post-Contingency actions are provided to expand on the term "all other available System adjustments" that should have been made prior to planning to utilize load shedding:

- Generation commitment and re-dispatch regardless of economic cost, when the generation has a significant impact on the SOL exceedance.
- Curtailment and adjustment of Interchange regardless of economic cost, when the Curtailment or adjustment of Interchange has a significant impact on the SOL exceedance.
- Transmission re-configuration (only if studies shows that the re-configuration does not put more load at risk or create other unacceptable system performance)

Transmission re-configuration that does place more load at risk or create other unacceptable system performance issues is not required to be used prior to planned manual load shedding. As an example the reconfiguration of a looped network into a series of radial connections to avoid planned post contingency manual load shedding could be a re-configuration that puts more load at risk. In those circumstances the TOP and RC must select that option that best fits their operating conditions and Requirement R6 Part 6.4 is not intended to prescribe one approach over the other. Planned "manual" load shedding would be load shed plans, as part of an Operating Plan, and is load that would be shed as part of an Operator Instruction or taking action to shed the load in Real-time. Reconfiguration of a system in Real-time to avoid or lessen the amount of planned manual load shed or reconfiguration of a system in Real-time that creates additional "consequential" load loss is not part of "planned manual load shedding". Furthermore, the "all other available System adjustments" would apply only to those adjustments studied by the TOP or RC at the time of the Operating Planning Analysis and not to system adjustments that might be found during a post event review days or weeks later. Part 6.4 is an addition to the RC's SOL methodology and the RC can provide additional clarity as appropriate to their circumstances.

**Planned manual load shedding in the context of Requirement R6 Part 6.4 is specific to what could be considered "firm" load, and would not include non-firm load, interruptible load, or any other load that has an arrangement that allows the load to be shed or interrupted when needed.**

## Requirement R7

- R7.** Each Reliability Coordinator shall include in its SOL methodology a risk-based approach for determining how SOL exceedances identified as part of Real-time monitoring and Real-time Assessments must be communicated and if so, the timeframe that communication must occur. The approach shall include:
- 7.1.** A requirement that the following SOL exceedances will always be communicated, within a timeframe identified by the Reliability Coordinator.
    - 7.1.1.** IROL exceedances
    - 7.1.2.** SOL exceedances of stability limits;
    - 7.1.3.** Post-contingency SOL exceedances that are identified to have a validated risk of instability, Cascading Outages, and uncontrolled separation
    - 7.1.4.** Pre-contingency SOL exceedances of Facility Ratings
    - 7.1.5.** Pre-contingency SOL exceedances of normal minimum System Voltage Limits.
  - 7.2.** A requirement that the following SOL exceedances must be communicated, if not resolved within 30 minutes, within a timeframe identified by the Reliability Coordinator.
    - 7.2.1.** Post-contingency SOL exceedances of Facility Ratings and emergency System Voltage limits
    - 7.2.2.** Pre-contingency SOL exceedances of normal maximum System Voltage Limits.

## Rationale R7

The changes in proposed FAC-011-4 help to provide clarity by requiring a performance framework for determining SOL exceedances in the RC's SOL methodology. This provides better uniformity in determining what is and isn't an SOL exceedance. This clarity may increase the instances of what is determined to be an SOL exceedance and thus increase the instances of communications that are required consistent with TOP-001-4 Requirement R15 (as well as IRO-008-2 Requirements R5 and R6) which states, *"Each Transmission Operator shall inform its Reliability Coordinator of actions taken to return the System to within limits when a SOL has been exceeded."*

Concerns were raised as to the effect on Real-time System Operators being required to communicate every SOL exceedance, especially those which were considered short duration SOL exceedances (e.g. less than 15 min, 30 min). This could be a significant increase for entities that historically performed RTAs more frequent than the required 30 minutes. Proposed FAC-011-4 Requirement R7 addresses this concern by requiring the RC to include in its SOL methodology a risk-based approach for determining how SOL exceedances identified as part of Real-time monitoring and Real-time Assessments must be communicated and if so, with what priority. This will ensure consistency within an RC's area between the RC and its TOPs.

Part 7.1 requires that the risk based approach require that "IROL exceedances, SOL exceedances of stability limits, post-contingency SOL exceedances that are identified to have a validated risk of

instability, Cascading Outages, and uncontrolled separation and pre-contingency SOL exceedances of Facility Ratings and pre-contingency Minimum System Voltage Limits will always be communicated”. While typically less frequent, these subset of SOL exceedances were determined to be of a higher risk and must always be communicated between TOP’s and RC’s. The RC must identify the priority of communications during circumstances where multiple SOL exceedances may exist.

Part 7.2 requires that the risk based approach require that “Post-contingency SOL exceedances of Facility Ratings and System Voltage limits and pre-contingency Normal Maximum System Voltage Limits must be communicated, if not resolved, within a timeframe identified by the RC which cannot exceed 30 minutes”. While typically more frequent, these subset of SOL exceedances were determined to be of a lower risk allow the RC to identify a timeframe which cannot exceed 30 minutes whereby if the SOL exceedance is mitigated (no longer an SOL exceedance) within the identified timeframe (e.g. 15min, 30 min, etc.), the SOL exceedance would not be required to be communicated to the TOP or RC. The RC must identify the priority of communications during circumstances where multiple SOL exceedances may exist.

Nothing prohibits an RC from requiring all or an additional subset of SOL exceedances than what is identified in Part 7.1 from being communicated. Nothing prohibits a Real-time System Operator from communicating beyond what is required or in line with other good utility practice (e.g. troubleshooting or communicating). These provisions are meant to ensure that a risk based approach can be applied to prevent low risk or after the fact communications from distracting System Operators from other higher priority tasks.

This proposed requirement is coordinated with proposed changes to TOP-001-5 Requirement R15 which states “*Each Transmission Operator shall inform its Reliability Coordinator of actions taken to return the System to within limits when a SOL has been exceeded **in accordance with its Reliability Coordinator’s SOL methodology.***” and with proposed IRO-008-3 Requirements R5 and R6 which state, “*Each Transmission Operator shall inform its Reliability Coordinator of actions taken to return the System to within limits when a SOL has been exceeded **in accordance with its Reliability Coordinator’s SOL methodology.***” and “*Each Reliability Coordinator shall notify, **in accordance with SOL methodology, impacted Transmission Operators and Balancing Authorities within its Reliability Coordinator Area, and other impacted Reliability Coordinators as indicated in its Operating Plan, when the System Operating Limit (SOL) or Interconnection Reliability Operating Limit (IROL) exceedance identified in Requirement R5 has been prevented or mitigated.***”, respectfully.

## **Requirement R8**

**R8.** Each Reliability Coordinator shall include in its SOL methodology:

- 8.1.** A description of how to identify the subset of SOLs that qualify as Interconnection Reliability Operating Limits (IROLs).
- 8.2.** Criteria for determining when exceeding a SOL qualifies as exceeding an IROL and criteria for developing any associated IROL T<sub>v</sub>.

### **Rationale R8**

The two IROL related requirements in FAC-011-3 were preserved under Requirement R8. Part 8.2 utilizes terminology consistent with proposed FAC-011-4, and the IRO/TOP NERC Reliability Standards by replacing “violating” with “exceeding”. It also inserts “exceeding” before the IROL to better harmonize with proposed FAC-011-4, and the IRO/TOP NERC Reliability Standards.

### **Requirement R9**

**R9.** Each Reliability Coordinator shall provide its SOL methodology to:

- 9.1.** Each Reliability Coordinator that requests and indicates it has a reliability-related need within 30 days of a request.
- 9.2.** Each of the following entities prior to the effective date of the SOL methodology:
  - 9.2.1.** Each adjacent Reliability Coordinator within the same Interconnection;
  - 9.2.2.** Each Planning Coordinator and Transmission Planner that is responsible for planning any portion of the Reliability Coordinator Area;
  - 9.2.3.** Each Transmission Operator within its Reliability Coordinator Area; and
  - 9.2.4.** Each Reliability Coordinator that has requested to receive updates and indicated it had a reliability-related need.

### **Rationale R9**

Requirement R9 preserves the reliability objective of providing the SOL methodology to the appropriate entities from Requirement R4 of FAC-011-3. Requirement R8 Part 8.1 mandates that an RC provide its SOL methodology to any requesting RC that indicates a reliability-related need within 30 calendar days of such request rather than prior to the effective date of the SOL methodology. Additionally, requirement 9 Part 9.2 enforces provision to those entities that would require notification of an update or change to the RC’s SOL methodology.

In Requirement R9 Part 9.2.2, Planning Coordinator (PC), not Planning Authority, was used to be consistent with the Functional Model as well as to be consistent with TPL-001. Requirement R9 Part 9.2.2 also uses “responsible for planning” instead of “models any portion of” to distinguish those PCs and Transmission Planners (TPs) who have a reliability-related need from a PC/TP who simply has acquired a model that contains a portion of the RC Area, but does not plan for that area. Requirement R9 Part 9.2.4 differs from Requirement R9 Parts 9.2.1 through 9.2.3 in that it mandates provision of the SOL methodology to non-adjacent RCs that have specifically requested to receive updates, and indicated they had a reliability-related need.

Exhibit C-2

Technical Rationale  
FAC-014-3



# Technical Rationale for Reliability Standard FAC-014-3

April 2021

## FAC-014-3 – Establish and Communicate System Operating Limit

### Requirement R1

Each Reliability Coordinator shall establish Interconnection Reliability Operating Limits (IROLs) for its Reliability Coordinator Area in accordance with its System Operating Limit methodology (SOL methodology).

#### Rationale R1

Reliability Standard FAC-014-2 Requirement R1 requires that the Reliability Coordinator (RC) ensure that System Operating Limits (SOLs), including Interconnection Reliability Operating Limits (IROLs), for its RC Area are established and that the SOLs (including IROLs) are consistent with its SOL methodology.

Furthermore, Requirement R2 of FAC-014-2 requires the Transmission Operator (TOP) to establish SOLs consistent with its RC's SOL methodology.

Under this structure the RC is responsible for ensuring that SOLs established by the TOP, per Requirement R2, are consistent with the RC's SOL methodology. This creates a situation where the RC is responsible for "ensuring" the actions of the TOP.

Accordingly, if the TOP does not establish SOLs per its RC's SOL methodology, then 1) the TOP is in violation of Requirement R2, and 2) the RC by default is in violation of Requirement R1 because the RC did not ensure that the TOP's SOL was consistent with its SOL methodology.

The proposed revision addresses this issue and clarifies the appropriate responsibilities of the respective functional entities. Additionally, this requirement carries forward the obligation of the RC to establish IROLs for its RC Area. The RC maintains primary responsibility for establishment of IROLs because these limits have the potential to impact a Wide-area.

### Requirement R2

Each Transmission Operator shall establish System Operating Limits (SOL) for its portion of the Reliability Coordinator Area in accordance with its Reliability Coordinator's SOL methodology.



## **Rationale R2**

Requirement R2 preserves the intent of Requirement R2 of FAC-014-2.

The standard drafting team (SDT) removed language from the existing FAC-014-2 Requirement R2 that states the TOP “shall establish SOLs (as directed by its Reliability Coordinator)” because it causes confusion and may be incorrectly understood to mean that the TOPs are only required to establish SOLs if they have been “directed to by their RC.” This is not the intended meaning of the requirement, thus, the SDT has removed the unnecessary and potentially confusing language. The proposed language makes clear that the TOP is the entity responsible for establishing SOLs for its portion of the Reliability Coordinator Area, and that these SOLs must be established in accordance with the RC’s SOL methodology.

## **Requirement R3**

The Transmission Operator shall provide its SOLs to its Reliability Coordinator.

### **Rationale R3**

Requirement R3 requires TOPs to provide the SOLs it established (under Requirement R2) to the RC. The TOP should refer to the RC’s documented data specification necessary for the RC to perform Operational Planning Analyses, Real-time monitoring and Real-time assessments under IRO-010-2 for any guidance or requirements regarding the provision of SOLs from the TOP. For example, the RC may wish to specify the periodicity and format in which the data should be communicated. The RC may choose to also provide this or any additional guidance within its SOL methodology. If no such information is given, the TOP may provide SOLs as per other terms agreed upon with the RC.

This requirement was previously covered under FAC-014-2 Requirement R5.2 but was moved to a more logical position in the standard, immediately following Requirement R2 for establishing SOLs.

The SDT recognizes that the provision of SOL information from the TOP to the RC may also be addressed via IRO-010-2. However, the proposed requirement may also be utilized for SOL information other than what is utilized for Operational Planning Analysis (OPA), Real-time Assessment (RTA) and Real-time monitoring. In such instances, the timing requirements should be coordinated between the data specification document and the RC’s SOL methodology.

Requirement R3 sets a common expectation across industry of the minimum actions any TOP must take when communicating SOLs to their RC. It’s important for this requirement to remain within FAC-014-3 to ensure SOLs are communicated from the TOP to the RC in case IRO-010-2 is modified or removed in future revisions to the standards.

## **Requirement R4**

Each Reliability Coordinator shall establish stability limits when an identified instability impacts adjacent Reliability Coordinator Areas or more than one Transmission Operator in its Reliability Coordinator Area in accordance with its SOL methodology.

## **Rationale R4**

Requirement R4 requires that the RC establish stability limits when the limit impacts more than one TOP in its RC Area. This ensures that the RC, who has wide-area responsibility, will establish such stability limits and prevent any gaps in identification and monitoring of stability limits that impacts more than one TOP in its RC Area. TOPs are still required to establish stability limits that are within its TOP area (including Generator Operator areas interconnected to its TOP area). The requirement establishes the end condition, which is the RC being responsible for establishing a stability limit that impacts more than one TOP regardless of whether that stability limit was originally calculated by the RC or one of the impacted TOPs. In the case where the stability limit impacts an adjacent RC or multiple TOPs which may or may not be in the same RC area, the RC establishing the stability limit shall use its own methodology and communicate the limit to the adjacent RC(s) or TOP(s) appropriately in accordance with other NERC standards requiring the communication of SOL and IROL related information (i.e. currently in effect IRO-008-2 Requirement R5, IRO-014-3 Requirements R1.4 and R1.5 and FAC-014-3 Requirement R5.3). Should there be a difference in limits established by each of the adjacent RCs or multiple TOPs; the more conservative of the two limits should be the one used in Operations in accordance with IRO-009-2 Requirement R3 or TOP-001-4 Requirement R18 respectively.

RCs who have asynchronous connections should consider the impact of all possible transfer levels across those connections including when those connections are not available if lost by contingency or forced outage.

## **Requirement R5**

Each Reliability Coordinator shall provide: *[Violation Risk Factor: High] [Time Horizon: Operations Planning, Same-day Operations, Real-Time Operations]*

- 5.1** Each Planning Coordinator and each Transmission Planner within its Reliability Coordinator Area, the SOLs for its Reliability Coordinator Area (including the subset of SOLs that are IROLs) at least once every twelve calendar months. *[Time Horizon: Operations Planning]*
- 5.2** Each impacted Planning Coordinator and each impacted Transmission Planner within its Reliability Coordinator Area, the following information for each established stability limit and each established IROL at least once every twelve calendar months: *[Time Horizon: Operations Planning]*
  - 5.2.1** The value of the stability limit or IROL;
  - 5.2.2** Identification of the Facilities that are critical to the derivation of the stability limit or the IROL;
  - 5.2.3** The associated IROL  $T_v$  for any IROL;
  - 5.2.4** The associated critical Contingency(ies);
  - 5.2.5** A description of system conditions associated with the stability limit or IROL; and

- 5.2.6** The type of limitation represented by the stability limit or IROL (e.g., voltage collapse, angular stability).
- 5.3** Each impacted Transmission Operator within its Reliability Coordinator Area, the value of the stability limits established pursuant to Requirement R4 and each IROL established pursuant to Requirement R1, in an agreed upon time frame necessary for inclusion in the Transmission Operator’s Operational Planning Analyses, Real-time monitoring, and Real-time Assessments. *[Time Horizon: Operations Planning, Same-day Operations, Real-Time Operations]*
- 5.4** Each impacted Transmission Operator within its Reliability Coordinator Area, the information identified in Requirement R5 Parts 5.2.2 – 5.2.6 for each established stability limit and each established IROL, and any updates to that information within an agreed upon time frame necessary for inclusion in the Transmission Operator’s Operational Planning Analyses. *[Time Horizon: Operations Planning, Same-day Operations, Real-Time Operations]*
- 5.5** Each requesting Transmission Operator within its Reliability Coordinator Area, requested SOL information for its Reliability Coordinator Area, on a mutually agreed upon schedule. *[Time Horizon: Operations Planning]*
- 5.6** Each impacted Generator Owner or Transmission Owner, within its Reliability Coordinator Area, with a list of their Facilities that have been identified as critical to the derivation of an IROL and its associated critical contingencies at least once every twelve calendar months. *[Time Horizon: Operations Planning]*

### **Rationale R5**

Requirement R5 requires the RC to provide SOLs (including the subset that are IROLs) and any updates to those SOLs to Planning Coordinators (PCs), Transmission Planners (TPs) and Transmission Operators (TOPs). This is an improvement over Requirement R5 in FAC-014-2 because it provides additional clarity on when the RC is responsible for performing these tasks. FAC-014-2 Requirement R5 includes the triggering clause for RCs to provide SOLs when entities “provide a written request that includes a schedule for delivery of those limits”, while Requirement R5 of FAC-014-3 clearly identifies the RC’s responsibilities with or without a request. This also removes confusion associated with FAC-010 in terms of SOLs existing in the planning horizon. All requirements pertaining to SOLs in the planning horizon have thus been removed.

The requirement addresses varying needs in terms of both the content and the frequency at which the information is provided. This requirement also complements existing NERC requirements that provide a construct for communication of SOLs and SOL-related information (e.g. TOP-003-3, IRO-010-2, IRO-014-2) to prevent redundancies in requirements. TOP-to-TOP SOL information communication is addressed in TOP-003-3. RC-to-RC SOL information communication is addressed in IRO-014-2. TOP-to-RC information communication is addressed in Requirement R3 and may be addressed in IRO-010-2.

Requirement R5 Part 5.1 requires the RC to provide the impacted PCs and TPs in its RC Area all SOLs and relevant SOL information at least once every 12 calendar months. This provides the PC and the TP the relevant information necessary for their annual assessments; however nothing precludes the PC and TP from requesting this information more frequently. Nothing prohibits an RC from sharing such information outside of a NERC Reliability Standard for other non-reliability related purposes.

Requirement R5 Part 5.2 requires the RC to provide the impacted PCs and TPs with additional specific information (consistent with FAC-014-2 R5.1.1 - R5.1.4) for stability limits and IROLs at least once every 12 calendar months. It is expected that PCs do not need more frequent updates as most of their assessments (and their respective TPs assessments) are performed on an annual cycle.

In addition, Requirement R5 Part 5.2.5 requires the RC to provide the impacted PCs and TPs with unique system conditions associated with a particular stability limit or IROL as opposed to generic study conditions directed at covering all (or a group of) stability limits which may be included in the RC's SOL methodology as required by, Requirement R4 Part 4.4 in FAC-011-4. For example, where the RC's SOL methodology may describe that stability limits must be verified for "summer peak", "winter peak", "minimum demand" and "shoulder periods", the information provided under , Requirement R5 Part 5.2.5 would identify whether the particular stability limit was present in all or just one of those conditions.

Requirement R5 Part 5.3 requires the RC to provide the impacted TOPs within its RC Area the value of the stability limits established in Requirement R4 and IROLs established in Requirement R1 in the Real-time Operations time horizon. This recognizes that the actual numerical "limit" (whether a new limit or modification of an existing one) may change based on varying system topology and thus those limit values must be provided in a timeframe designed to meet the impacted TOP's needs for their OPA, Real-time monitoring, and RTA. In the case where the stability limit impacts an adjacent RC or multiple TOPs which may or may not be in the same RC area, the RC establishing the stability limit shall use its own methodology and communicate the limit to the adjacent RC(s) or TOP(s) appropriately in accordance with other NERC standards requiring the communication SOL and IROL related information (i.e. currently in effect IRO-008-2 Requirement R5 and IRO-014-Requirements 1.4 and 1.5)). Should there be a difference in limits established by each of the adjacent RCs or multiple TOPs; the more conservative of the two limits should be the one used in Operations in accordance with IRO-009-2 Requirement R3 or TOP-001-4 Requirement R18 respectively.

Requirement R5 Part 5.4 requires the RC to provide the impacted TOPs additional specific information (consistent with FAC-014-2 R5.1.1-5.1.4) for stability limits and IROLs within same-day or Operations Planning time horizon. This additional information is essential for the TOP's OPA; however, it can be communicated within a longer-term agreed upon time frame outside the Real-time Operations time horizon.

Additionally, Requirement R5 Part 5.5 requires that if a TOP requests any SOL information beyond what impacts that TOP, the RC must provide this SOL information as well. For example, in deriving a new SOL that may impact adjacent TOPs, a TOP may need more information from the RC on related SOLs in other TOP areas within the region that could impact their derivation. Requirement R5, Parts 5.3 through 5.5, require that the related information be provided in a mutually agreed upon schedule to ensure the TOP's needs are met (e.g. OPA, RTA, etc.) and the RC's ability to meet those needs are taken into consideration.

Finally, Requirement R5, part 5.6, requires that the RC must provide each impacted Generation Owner or Transmission Owner within its Reliability Coordinator area with a list of Facilities that they can use to satisfy the criteria in Attachment 1 part 2.6 in CIP-002 and 4.1.1.3 in CIP-014. Of the three possible entities, RC, TP and PC listed in CIP-002 and CIP-014 that could deliver this information to the TOs and GOs, the RC is ultimately responsible given they're required to establish IROLs. Thus, the requirement for provision of the list of Facilities identified as critical to the derivation of an IROL and its associated critical contingencies should rest with the RC. The SDT also felt that some known periodicity of information provision, per this requirement, seemed appropriate. After industry comment, an annual periodicity was chosen. This timeframe should allow sufficient analysis to document IROLs that will persist, and need monitoring by the RC and any necessary action by asset owners, per the CIP standards. Those IROL like conditions which may manifest in real time, due to forced outages are not appropriate for consideration until reviewed by the RC to determine if they are to be established as an IROL to prevent the condition from reoccurring, and warrant reporting per the standard.

## **Requirement R6**

Each Planning Coordinator and each Transmission Planner shall implement a documented process to use Facility Ratings, System steady-state voltage limits and stability criteria in its Planning Assessment of Near Term Transmission Planning Horizon that are equally limiting or more limiting than the criteria for Facility Ratings, System Voltage Limits and stability described in its Reliability Coordinator's SOL methodology.

- The Planning Coordinator may use less limiting Facility Ratings, System steady-state voltage limits and stability criteria if it provides a technical rationale to each affected Transmission Planner, Transmission Operator and Reliability Coordinator.
- The Transmission Planner may use less limiting Facility Ratings, System steady-state voltage limits and stability criteria if it provides a technical rationale to each affected Planning Coordinator, Transmission Operator and Reliability Coordinator.

## **Rationale R6**

The purpose of TPL-001 is to "...develop a Bulk Electric System (BES) that will operate reliably over a broad spectrum of System conditions and following a wide range of probable Contingencies." Because the Planning Assessment (including the Corrective Action Plan) is the primary output of TPL-001, planning criteria used in developing the Planning Assessment should support the eventual operation of BES Facilities.

Requirement R6 was drafted to ensure the appropriate use of applicable Facility Ratings, System steady-state voltage limits, and stability performance criteria in operating and planning models. Analysis of these models determine System needs, potential future transmission expansion, and other Corrective Action Plans for reliable System operations. Therefore, it is imperative that the System is planned in such a way to support the successful operation of Facilities when they are placed in service.

Requirement R6 provides a mechanism for the coordination of Facility Ratings, System steady-state voltage limits, and stability performance criteria in planning models to those established in accordance with the RC's SOL methodology. Since the analysis of planning models determines what Facilities are constructed or modified, the application of Facility Ratings, System steady-state voltage limits, and stability performance criteria used in studies that support the development of the Planning Assessment should be equally limiting or more limiting than those established in accordance with the RC's SOL methodology. Otherwise, operators could be unduly limited by constraints that were not identified in preceding planning studies.

The Near-Term Transmission Planning Horizon is specified because assumptions regarding the topology of the transmission system, forecast load and generation, etc. are more certain earlier in the Planning Horizon. Additionally, construction activities or other Corrective Action Plans are more likely to be in the implementation phase or finalized in this period.

**Facility Ratings:**

Reliability Standard MOD-032 requires the modeling data in a PC area be coordinated between the PC and applicable TP. It is the opinion of the standard drafting team (SDT) that the resulting coordination is the appropriate means for consistency between the PC and TP in ensuring Facility Ratings included in planning models are equally limiting or more limiting than the Facility Ratings established in accordance with the RC's SOL methodology. This is important because Planning Assessments and Corrective Action Plans are developed based on analysis of these models (TPL-001).

The intent of Requirement R6 is not to change, limit, or modify Facility Ratings determined by the equipment owner per FAC-008, nor allow the PCs nor TPs to revise those limits. The intent is to utilize those owner-provided Facility Ratings such that the System is planned to support the reliable operation of that System. This is accomplished by requiring the PC and TP to use the owner-provided Facility Ratings that are equally limiting or more limiting than those established in accordance with the RC's SOL methodology. This is not intended to imply the RC has authority over the PCs and TPs planning a portion of the RC area in the development of the Planning Assessment. It does, however, facilitate communication between planning and operating entities so that analysis of the System by these entities are coordinated.

The SDT recognizes there are instances where it may be appropriate for planning models to have less limiting Facility Ratings than those established in accordance with the RC's SOL methodology. As such, Requirement R6 explicitly allows for exceptions when a technical rationale is provided to



the appropriate entities in accordance with the requirement. The obvious example for such an exception is a facility where the PC / TP has assumed an upgrade which increases the Facility Rating (typically, the thermal limit) of the equipment in question.

Furthermore, it is the SDT's intent to clarify that Facility Ratings that result from variables such as the implementation of future Corrective Action Plans, or the use of ambient temperature assumptions in seasonal planning models that differ from those ambient weather assumptions used in operational analyses and monitoring in real time, may be used. Although they may be less limiting than those in the RC's SOL methodology in certain instances, it is understood that seasonal assumptions and capacity increases due to upgrade are appropriately included in future planning models. These provisions should be included in the documented technical rationale provided to the appropriate entities in accordance with the requirement.

**System Steady-State Voltage Limits:**

Regarding voltage performance criteria, the intent of this requirement is to supplement Requirement R5 of TPL-001-4 which states, "Each TP and PC shall have criteria for acceptable System steady state voltage limits, post-Contingency voltage deviations, and the transient voltage response for its System. For transient voltage response, the criteria shall at a minimum, specify a low voltage level and a maximum length of time that transient voltages may remain below that level." When determining the criteria for System steady-state voltage limits in accordance with TPL-001-4 Requirement R5, PCs and TPs are required to implement the process described in FAC-014-3 Requirement R6. Per FAC-014-3, R6, the PC and TP are required to use System steady-state voltage limits that are equally limiting or more limiting than the System Voltage Limits established in accordance with the RC's SOL methodology. This does not give the RC authority over the PCs and TPs, responsible for planning a portion of the RC area, in the development of the Planning Assessment. It does, however, facilitate communication between planning and operating entities so that analysis of the System by these entities are coordinated.

**Stability Performance Criteria:**

Regarding stability performance criteria, the intent of this requirement is to supplement the performance of stability analysis by the PC and TP per TPL-001. When PCs and TPs perform the relevant stability analyses in accordance with TPL-001, they are required to implement the process in FAC-014-3 Requirement R6. Per FAC-014-3, R6, the PC and TP are required to use stability performance criteria that are equally limiting or more limiting than the criteria established in accordance with the RC's SOL methodology. This does not give the RC authority over the PCs and TPs, responsible for planning a portion of the RC area, in the development of the Planning Assessment. It does, however, facilitate communication between planning and operating entities so that analysis of the System by these entities are coordinated.

**Requirement R7**

Each Planning Coordinator and each Transmission Planner shall annually communicate the following information for Corrective Action Plans developed to address any instability identified in its Planning

Assessment of the Near-Term Transmission Planning Horizon to each impacted Transmission Operator and Reliability Coordinator. This communication shall include:

- 7.1** The Corrective Action Plan developed to mitigate the identified instability, including any automatic control or operator-assisted actions (such as Remedial Action Schemes, under voltage load shedding, or any Operating Procedures);
- 7.2** The type of instability addressed by the Corrective Action Plan (e.g. steady-state and/or transient voltage instability, angular instability including generating unit loss of synchronism and/or unacceptable damping);
- 7.3** The associated stability criteria violation requiring the Corrective Action Plan (e.g. violation of transient voltage response criteria or damping rate criteria);
- 7.4** The planning event Contingency(ies) associated with the identified instability requiring the Corrective Action Plan;
- 7.5** The System conditions and Facilities associated with the identified instability requiring the Corrective Action Plan.

### **Rationale R7**

IRO-017-1 Requirement R3 requires PCs and TPs to provide their Planning Assessments to impacted RCs. However, Requirement R2 Part 2.4 and Requirement R4 in TPL-001-4, which outline the Stability analysis portion of the Planning Assessment and the associated Corrective Action Plan, do not provide for the level of detail prescribed in FAC-014-3 Requirement R7. Therefore, this requirement was drafted to ensure the appropriate details regarding any potential instability identified in the Planning Assessment for the Near-Term Transmission Planning Horizon are provided to impacted RC and TOPs.

The information itemized in FAC-014-3 Requirement R7 is a key consideration for RCs and TOPs in the establishment of SOLs. For example, a study might indicate that System instability was avoided through the implementation of an operational measure, or Remedial Action Scheme (RAS). In this example, if the operational measure or RAS were not employed, the study would indicate instability in response to the associated Contingency. This information is critical for operator awareness of any automatic or manual actions that are required to prevent instability. Without this information, operators may be unaware of these risks and the measures required to address them. Existing FAC-014-2, Requirement R6 requires similar, though less detailed, information is shared by the planning with the RC. The SDT believes FAC-014-3, Requirement R7, improves upon this requirement and provides added clear and concise information to its impacted RCs and TOPs.

In addition, FAC-014-3 Requirement R7 Part 7.4 is useful information which supports FAC-014-3 Requirement R8. The information from Requirement R8 supports a number of other standards which require the PC and TP to provide information regarding instability, Cascading, and uncontrolled separation that adversely impacts the reliability of the BES to the TO and GO.



## **Requirement R8**

Each Planning Coordinator and each Transmission Planner shall annually communicate to each impacted Transmission Owner and Generation Owner a list of their Facilities that comprise the planning event Contingency(ies) that would cause instability, Cascading or uncontrolled separation that adversely impacts the reliability of the BES as identified in its Planning Assessment of the Near-Term Transmission Planning Horizon.

### **Rationale R8**

This requirement was drafted to ensure the appropriate details (i.e. Facilities) regarding potential instability, Cascading, or uncontrolled separation identified in the Stability portion of the Planning Assessment for the Near-Term Transmission Planning Horizon are provided to impacted Transmission and Generation Owners. Impacted Transmission and Generation Owners consist of those entities who have facilities requiring notification and **does not** imply that all Transmission and Generation Owners need notification of whether they have facilities requiring notification or not. This is necessary to ensure Facility owners receive this input to identify the Facilities that, as required by other Reliability Standards, require some level of protection, hardening, or increased vegetative management provisions. This requirement further supports the SDT's proposed changes to other Reliability Standards being updated to account for the retirement of FAC-010.

Furthermore, this requirement addresses the FERC Order No. 777 directive identified in the Standard Authorization Request (SAR) for project 2015-09, requesting a requirement be added for the communication of IROL information to Transmission Owners. This requirement, coupled with Requirement 5.6, provides annual notifications to Facility owners from both operating and planning entities, whereas no such timely notification requirements exist in the standards today.

Exhibit C-3

Technical Rationale  
TOP-001-6

# Technical Rationale for Reliability Standard TOP-001-6

April 2021

## TOP-001-6 – Transmission Operations

### Rationale

Rationale text from the development of TOP-001-3 in Project 2014-03 and TOP-001-4 in Project 2016-01 follows. Additional information can be found on the [Project 2014-03](#) and [Project 2016-01](#) pages.

### Rationale for Requirement R3:

The phrase ‘cannot be physically implemented’ means that a Transmission Operator may request something to be done that is not physically possible due to its lack of knowledge of the system involved.

### Rationale for Requirement R10:

New proposed Requirement R10 is derived from approved IRO-003-2, Requirement R1, adapted to the Transmission Operator Area. This new requirement is in response to NOPR paragraph 60 concerning monitoring capabilities for the Transmission Operator. New Requirement R11 covers the Balancing Authorities. Monitoring of external systems can be accomplished via data links.

The revised requirement addresses directives for Transmission Operator (TOP) monitoring of some non-Bulk Electric System (BES) facilities as necessary for determining System Operating Limit (SOL) exceedances (FERC Order No. 817 Para 35-36). The proposed requirement corresponds with approved IRO-002-4 Requirement R4 (proposed IRO-002-5 Requirement R5), which specifies the Reliability Coordinator's (RC) monitoring responsibilities for determining SOL exceedances.

The intent of the requirement is to ensure that all facilities (i.e., BES and non-BES) that can adversely impact reliability of the BES are monitored. As used in TOP and IRO Reliability Standards, monitoring involves observing operating status and operating values in Real-time for awareness of system conditions. The facilities that are necessary for determining SOL exceedances should be either designated as part of the BES, or otherwise be incorporated into monitoring when identified by planning and operating studies such as the Operational Planning Analysis (OPA) required by TOP-002-4 Requirement R1 and IRO-008-2 Requirement R1. The SDT recognizes that not all non-BES facilities that a TOP considers necessary for its monitoring needs will need to be included in the BES.

The non-BES facilities that the TOP is required to monitor are only those that are necessary for the TOP to determine SOL exceedances within its Transmission Operator Area. TOPs perform various analyses and

studies as part of their functional obligations that could lead to identification of non-BES facilities that should be monitored for determining SOL exceedances. Examples include:

- OPA;
- Real-time Assessments (RTA);
- Analysis performed by the TOP as part of BES Exception processing for including a facility in the BES; and
- Analysis which may be specified in the RC's outage coordination process that leads the TOP to identify a non-BES facility that should be temporarily monitored for determining SOL exceedances.

TOP-003-3 Requirement R1 specifies that the TOP shall develop a data specification which includes data and information needed by the TOP to support its OPAs, Real-time monitoring, and RTAs. This includes non-BES data and external network data as deemed necessary by the TOP.

The format of the proposed requirement has been changed from the approved standard to more clearly indicate which monitoring activities are required to be performed.

**Rationale for Requirement R13:**

The new Requirement R13 is in response to NOPR paragraphs 55 and 60 concerning Real-time analysis responsibilities for Transmission Operators and is copied from approved IRO-008-1, Requirement R2. The Transmission Operator's Operating Plan will describe how to perform the Real-time Assessment. The Operating Plan should contain instructions as to how to perform Operational Planning Analysis and Real-time Assessment with detailed instructions and timing requirements as to how to adapt to conditions where processes, procedures, and automated software systems are not available (if used). This could include instructions such as an indication that no actions may be required if system conditions have not changed significantly and that previous Contingency analysis or Real-time Assessments may be used in such a situation.

**Rationale for Requirement R14:**

The original Requirement R8 was deleted and original Requirements R9 and R11 were revised in order to respond to NOPR paragraph 42 which raised the issue of handling all SOLs and not just a sub-set of SOLs. The SDT has developed a white paper on SOL exceedances that explains its intent on what needs to be contained in such an Operating Plan. These Operating Plans are developed and documented in advance of Real-time and may be developed from Operational Planning Assessments required per proposed TOP-002-4 or other assessments. Operating Plans could be augmented by temporary operating guides which outline prevention/mitigation plans for specific situations which are identified day-to-day in an Operational Planning Assessment or a Real-time Assessment. The intent is to have a plan and philosophy that can be followed by an operator.

FAC-011-4 R6 clarifies when an SOL exceedance is occurring and as such likely increases the number of SOL exceedances for some TOPs. This increased number of SOL exceedances could create an administrative burden on System Operators for entities that rely on operator logs as the primary form of

evidence for compliance. This would be an unintended consequence of interaction between the new FAC-011-4 R6 and TOP-001-4 Requirement 14, which states, “Each Transmission Operator shall initiate its Operating Plan to mitigate a SOL exceedance identified as part of its Real-time monitoring or Real-time Assessment.” This is because TOP-001-4 Requirement 14 treats all SOL exceedances equally and does not differentiate among them based on duration or risk to the BES.

Concerns were raised by drafting team members and observers as to the effect on Real-Time System Operators being required to log initiation of the Operating Plan for every SOL exceedance per TOP-001-4 R14, especially those which were considered short duration, low risk SOL exceedances that were actually successfully mitigated within a short-term time frame. This could distract System Operators to focus on compliance documentation during times when they should be fully committed to implementing the Operating Plan and mitigating the SOL exceedance.

The revised TOP-001-6 M14 addresses this concern by identifying examples of “other evidence” that can be utilized to support compliance which require less human intervention for capturing. Examples allowing TOPs to use other types of evidence such as system logs/records showing the SOL exceedance successfully mitigated in conjunction with Operating Plans is important because it clarifies that validation of successful SOL mitigation is the primary interest and focus of evidence. Successful SOL mitigation coupled with Operating Plans that have been prepared for utilization in the event of an SOL exceedance can demonstrate that the TOP initiated and implemented its Operating Plan. For example, providing outputs of State Estimator and/or Real-Time Contingency Analysis (with start time and end time of SOL exceedances) in conjunction with Operating Plans that outline roles and responsibilities between TOP and its RC in eliminating SOL exceedances, would document resolution of the SOL exceedance as well as the Operating Plan in use for the resolution. These should be sufficient evidence for Requirement R14 while reducing or eliminating the administrative burden on System Operators to manually generate compliance evidence via logging or recording actions.

These Operating Plans may be strengthened with clarifying information such as automatically switched or scheduled switching operating strategies/processes that describe how automatic control actions correct SOL exceedances, which can prevent unnecessary collection of evidence. Use of operating policies as a part of Operating Plan may include specific control actions (such as taking a transmission line out of service or disconnecting a generator for a low risk high voltage SOL exceedance) on post-contingent basis, and may be utilized if it was included into operating protocols and confirmed in real-time. Other records, such as binding constraint logs, could document the actions taken to alleviate certain thermal SOL exceedances through the role of redispatch algorithms that generate revised dispatch setpoints for generators to alleviate the constraint.

Finally, further evidence may include some of the operating protocols shared between a TOP and RC as part of the Operating Plan; they may support instances where the TOP and RC agree to each take certain predetermined actions and or share information. For example, if an RC had to initiate manual redispatch with a Generator Operator when a TOP initiated binding constraint was insufficient (e.g. not fast enough), the TOP may utilize RC-provided logs as evidence of compliance if the RC and TOP have agreed to share such information. Additionally, use of these joint operating protocols as evidence recognizes situations

and operating conditions when the RC initiates and implements an Operating Plan on behalf of TOP, per these joint operating protocols. In these situations, pre-specified actions taken by the TOP and RC and agreed upon in their joint operating protocols could allow the RC's binding constraint logs to be used by the TOP as evidence of compliance.

**Rationale for Requirement R15:**

Clarity of what is determined to be an SOL exceedance in new revision FAC-011-4 may increase, in some instances, the number of SOL exceedances and thus the communications that are required consistent with TOP-001-4 Requirement R15 (as well as IRO-008-2 Requirement R5 and R6) which states, "Each Transmission Operator shall inform its Reliability Coordinator of actions taken to return the System to within limits when a SOL has been exceeded."

Concerns were raised as to the effect on System Operators being required to communicate every SOL exceedance, especially those which were considered short duration, low risk, SOL exceedances (e.g. less than 15 min, 30 min). This could be a significant increase for entities that historically performed RTAs more frequent than the required 30 minutes. Proposed FAC-011-4 R7 addresses this concern by requiring the RC to include in its SOL methodology a risk-based approach for determining how SOL exceedances identified as part of Real-time monitoring and Real-time Assessments must be communicated and if so, with what priority. This will ensure consistency within an RC's area between the RC and its TOPs.

The use of the terminology "in accordance with its SOL methodology, aligns the notification requirements of TOP-001-5 R15 with the communication requirements identified in FAC-011-4 Requirement R7 around communication of SOL exceedances. For example, the SOL methodology could state that an RC and TOP sharing with each other real time monitoring and RTCA output information could provide clear communication and indications of when SOL exceedances appear and are mitigated in real time, meeting the requirements of the standard. This communication could range from simply RC and TOP sharing via ICCP output from the real time monitoring and RTCA output to operator to operator communications.

**Rationale for Requirements R16 and R17:**

In response to IERP Report recommendation 3 on authority.

**Rationale for Requirement R18:**

Moved from approved IRO-005-3.1a, Requirement R10. Transmission Service Provider, Distribution Provider, Load-Serving Entity, Generator Operator, and Purchasing-Selling Entity are deleted as those entities will receive instructions on limits from the responsible entities cited in the requirement. Note – Derived limits replaced by SOLs for clarity and specificity. SOLs include voltage, Stability, and thermal limits and are thus the most limiting factor.

**Rationale for Requirements R19 and R20 (R19, R20, R22, and R23 in TOP-001-4):**

[Note: Requirement R19 proposed for retirement under Project 2018-03 Standards Efficiency Review Retirements.]

The proposed changes address directives for redundancy and diverse routing of data exchange capabilities (FERC Order No. 817 Para 47).

Redundant and diversely routed data exchange capabilities consist of data exchange infrastructure components (e.g., switches, routers, servers, power supplies, and network cabling and communication paths between these components in the primary Control Center for the exchange of system operating data) that will provide continued functionality despite failure or malfunction of an individual component within the Transmission Operator's (TOP) primary Control Center. Redundant and diversely routed data exchange capabilities preclude single points of failure in primary Control Center data exchange infrastructure from halting the flow of Real-time data. Requirement R20 does not require automatic or instantaneous fail-over of data exchange capabilities. Redundancy and diverse routing may be achieved in various ways depending on the arrangement of the infrastructure or hardware within the TOP's primary Control Center.

The reliability objective of redundancy is to provide for continued data exchange functionality during outages, maintenance, or testing of data exchange infrastructure. For periods of planned or unplanned outages of individual data exchange components, the proposed requirements do not require additional redundant data exchange infrastructure components solely to provide for redundancy.

Infrastructure that is not within the TOP's primary Control Center is not addressed by the proposed requirement.

**Rationale for Requirement R21:**

The proposed requirement addresses directives for testing of data exchange capabilities used in primary Control Centers (FERC Order No. 817 Para 51).

A test for redundant functionality demonstrates that data exchange capabilities will continue to operate despite the malfunction or failure of an individual component (e.g., switches, routers, servers, power supplies, and network cabling and communication paths between these components in the primary Control Center for the exchange of system operating data). An entity's testing practices should, over time, examine the various failure modes of its data exchange capabilities. When an actual event successfully exercises the redundant functionality, it can be considered a test for the purposes of the proposed requirement.

**Rationale for Requirements R22 and R23:**

[Note: Requirement R22 proposed for retirement under Project 2018-03 Standards Efficiency Review Retirements]

The proposed changes address directives for redundancy and diverse routing of data exchange capabilities (FERC Order No. 817 Para 47).

Redundant and diversely routed data exchange capabilities consist of data exchange infrastructure components (e.g., switches, routers, servers, power supplies, and network cabling and communication



paths between these components in the primary Control Center for the exchange of system operating data) that will provide continued functionality despite failure or malfunction of an individual component within the Balancing Authority's (BA) primary Control Center. Redundant and diversely routed data exchange capabilities preclude single points of failure in primary Control Center data exchange infrastructure from halting the flow of Real-time data. Requirement R23 does not require automatic or instantaneous fail-over of data exchange capabilities. Redundancy and diverse routing may be achieved in various ways depending on the arrangement of the infrastructure or hardware within the BA's primary Control Center.

The reliability objective of redundancy is to provide for continued data exchange functionality during outages, maintenance, or testing of data exchange infrastructure. For periods of planned or unplanned outages of individual data exchange components, the proposed requirements do not require additional redundant data exchange infrastructure components solely to provide for redundancy.

Infrastructure that is not within the BA's primary Control Center is not addressed by the proposed requirement.

**Rationale for Requirement R24:**

The proposed requirement addresses directives for testing of data exchange capabilities used in primary Control Centers (FERC Order No. 817 Para 51).

A test for redundant functionality demonstrates that data exchange capabilities will continue to operate despite the malfunction or failure of an individual component (e.g., switches, routers, servers, power supplies, and network cabling and communication paths between these components in the primary Control Center for the exchange of system operating data). An entity's testing practices should, over time, examine the various failure modes of its data exchange capabilities. When an actual event successfully exercises the redundant functionality, it can be considered a test for the purposes of the proposed requirement.

**Rationale for R25:**

Requirement R25 was added to align the Real-time Assessments, Real-time Monitoring, and Operational Planning Analysis activities with the RC's SOL methodology. This will ensure that methods and frameworks that surround what is required in the SOL methodology are utilized during these activities (e.g. contingencies utilized, stability criteria, performance framework, etc.) in determining SOL exceedances.



Exhibit C-4

Technical Rationale  
IRO-008-3

# Technical Rationale for Reliability Standard

## IRO-008-3

April 2021

### **IRO-008-3 – Reliability Coordinator Operational Analyses and Real-Time Assessments**

#### **Rationale:**

During development of this standard, text boxes were embedded within the standard to explain the rationale for various parts of the standard. Upon Board of Trustees approval, the text from the rationale text boxes was moved to this section.

Changes made to the proposed definitions were made in order to respond to issues raised in NOPR paragraphs 55, 73, and 74 dealing with analysis of SOLs in all time horizons, questions on Protection Systems and Special Protection Systems in NOPR paragraph 78, and recommendations on phase angles from the SW Outage Report (recommendation 27). The intent of such changes is to ensure that Real-time Assessments contain sufficient details to result in an appropriate level of situational awareness. Some examples include: 1) analyzing phase angles which may result in the implementation of an Operating Plan to adjust generation or curtail transactions so that a Transmission facility may be returned to service, or 2) evaluating the impact of a modified Contingency resulting from the status change of a Special Protection Scheme from enabled/in-service to disabled/out-of-service.

#### **Rationale for R1:**

Revised in response to NOPR paragraph 96 on the obligation of Reliability Coordinators to monitor SOLs. Measure M1 revised for consistency with TOP-003-3, Measure M1.

#### **Rationale for R2 and R3:**

Requirements added in response to IERP and SW Outage Report recommendations concerning the coordination and review of plans.

#### **Rationale for R5 and R6:**

In Requirements R5 and R6 the use of the term ‘impacted’ and the tie to the Operating Plan where notification protocols will be set out should minimize the volume of notifications. The use of the terminology “in accordance with its SOL methodology, aligns the notification requirements with the communication requirements identified in FAC-011-4 Requirement R7 around communication of SOL exceedances. For example, the SOL methodology could state that an RC and TOP sharing with each other

real time monitoring and RTCA output information could provide clear communication and indications of when SOL exceedances appear and are mitigated in real time, meeting the requirements of the standard.

**Rationale for R7:**

Requirement R7 was added to align the Real-time Assessments, Real-time Monitoring, and Operational Planning Analysis activities with the RC's SOL methodology. This will ensure that methods and frameworks that surround what is required in the SOL methodology are utilized during these activities (e.g. contingencies utilized, stability criteria, performance framework, etc.) in determining SOL exceedances.

Exhibit C-5

Technical Rationale  
System Operating Limit Definition

# NERC Glossary Definition: System Operating Limit

## Term: "System Operating Limit"

### Definition:

#### Redline

~~All Facility Ratings, System Voltage Limits, and stability limits, applicable to The value (such as MW, Mvar, amperes, frequency or volts) that satisfies the most limiting of the prescribed operating criteria for a specified system configurations, used in Bulk Electric System operations for monitoring and assessing pre- and post-Contingency operating states. to ensure operation within acceptable reliability criteria. System Operating Limits are based upon certain operating criteria. These include, but are not limited to:~~

- ~~• Facility Ratings (applicable pre and post Contingency Equipment Ratings or Facility Ratings)~~
- ~~• transient stability ratings (applicable pre and post Contingency stability limits)~~
- ~~• voltage stability ratings (applicable pre and post Contingency voltage stability)~~
- ~~• system voltage limits (applicable pre and post Contingency voltage limits)~~

#### Clean

All Facility Ratings, System Voltage Limits, and stability limits, applicable to specified System configurations, used in Bulk Electric System operations for monitoring and assessing pre- and post-Contingency operating states.

## Introduction

The standard drafting team (“SDT”) for *Project 2015-09 Establish and Communicate System Operating Limits* developed these rationales to explain the modifications to the definition of the term “System Operating Limit” (“SOL”) to be incorporated into the Glossary of Terms Used in NERC Reliability Standards (“NERC Glossary”). As discussed below, the purpose of the proposed modified term is to provide greater clarity and consistency with the SOL concept and how SOLs work alongside operational performance criteria to result in reliable operations.

## Background

The use of SOLs is a foundational concept in NERC’s Reliability Standards, as operating within SOLs for the pre- and post-Contingency state is a primary aspect of reliable Bulk Electric System (“BES”) operations. An SOL is currently defined in the NERC Glossary as:

*The value (such as MW, Mvar, amperes, frequency or volts) that satisfies the most limiting of the prescribed operating criteria for a specified system configuration to ensure operation within acceptable reliability criteria. System Operating Limits are based upon certain operating criteria. These include, but are not limited to:*

- *Facility Ratings (applicable pre- and post-Contingency Equipment Ratings or Facility Ratings)*
- *transient stability ratings (applicable pre- and post- Contingency stability limits)*
- *voltage stability ratings (applicable pre- and post-Contingency voltage stability)*
- *system voltage limits (applicable pre- and post-Contingency voltage limits)*

SOLs are the primary focus of FAC standards FAC-010, FAC-011, and FAC-014. Per these FAC standards:

- Planning Coordinators are required to have a methodology for establishing SOLs in its area for use in the planning horizon (FAC-010-3).
- Planning Coordinators and Transmission Planners are required to establish SOLs for use in the planning horizon consistent with the Planning Coordinator’s SOL Methodology (FAC-014-2).
- Reliability Coordinators are required to have a methodology for establishing SOLs in its area for use in the operations horizon (FAC-011-3).
- TOPs are required to establish SOLs for use in the operations horizon consistent with the Reliability Coordinator’s SOL Methodology (FAC-014-2).

FAC-011-3 requirement R2 states that the “RC’s SOL Methodology shall include a requirement that SOLs provide BES performance consistent with the following.” The subsequent subparts to FAC-011-3 requirement R2 further describe pre-Contingency performance criteria (in R2.1), the post-Contingency performance criteria (in R2.2), and describe other rules related to the establishment of SOLs in the remaining subparts. The language in requirement R2 indicates that the SOLs established in accordance with

requirement R2 are expected to “provide” a level of pre- and post-Contingency reliability described in the subparts of requirement R2. Accordingly, the assessments of the pre-Contingency state and the post-Contingency state are expected to be performed as part of the SOL establishment process, yielding a set of SOLs that “provide” for meeting the performance criteria denoted in FAC-011 R2 and subparts. Requirements in FAC-014-2 then require the communication of those SOLs to the various operations and planning entities. TOP standards in effect at the time required TOPs to operate within these SOLs.

These FAC standards and related TOP standards established a construct for reliable operations. This SOL construct depicted in the body of Reliability Standards in effect in the 2007 timeframe is characterized by the following:

1. The TOPs and RCs would run studies for expected system conditions where the studies would examine the pre-Contingency state and the post-Contingency state.
2. If any performance criteria (in FAC-011 R2 subparts) were not being met in those studies, the TOP would establish an SOL which, if operated within, would result in all of those performance criteria being met.
3. The TOP would communicate those SOLs to System Operators.
4. The TOP System Operators would operate within those SOLs.

The TOP and IRO standards in effect prior to April 1, 2017 required TOPs to operate within these SOLs, the presumption being that if those SOLs were operated within in Real-time operations, then the acceptable pre- and post-Contingency operations criteria depicted in FAC-011-3 requirement R2 and subparts would be met.

It is important to note that prior to April 1, 2017 there were no Reliability Standards that required operational entities to perform assessments of the post-Contingency state in same-day or Real-time operations. Prior to April 1, 2017, the requirements associated with assessments of the post-Contingency state were folded into SOL establishment process – the establishment of SOLs that “provide” for meeting the documented pre- and post-Contingency performance criteria in FAC-011-3 requirement R2 and subparts.

The definition of SOL and the Reliability Standards that address SOLs – FAC-010, FAC-011, and FAC-014 – have remained essentially unchanged since their initial versions were approved and adopted in 2007. Since that time, many improvements have been made to the body of reliability standards, specifically those in the TPL, TOP, and IRO family of standards. The former TPL-001, -002, -003, and -004 Reliability Standards have been replaced with TPL-001-4, all of the TOP standards were replaced with the currently effective TOP-001, TOP-002, and TOP-003, and several IRO standards have been replaced as well. The definition of SOL and the FAC standards that address SOLs are inextricably linked to many of the TPL, TOP, and IRO standards, as they all address in some manner the foundational reliability concept of acceptable system performance. One of the primary objectives of Project 2015-09 is to make changes to the SOL definition and the related FAC standards to create better alignment with the currently effective TPL, TOP, and IRO

standards. The SDT's proposal to revise the definition of SOL improves clarity, reduces redundancy, and creates better alignment and continuity with the currently effective TOP and IRO standards.

Due to changes in the TOP and IRO Reliability Standards that became effective on April 1, 2017, this SOL construct described by the currently effective definition of SOL and the manner in which it is used in the FAC standards is not reflective of the construct encapsulated in the operational requirements in place today. The new TOP and IRO standards represent a new construct for managing reliability for the pre- and post-Contingency state. Under this new construct approved in Order No. 817<sup>1</sup>:

1. TOPs and RCs are required to ensure that an Operational Planning Analysis (OPA) is performed to assess whether the planned operations for the next-day will exceed any of its SOLs and IROLs<sup>2</sup>. The pre- and post-Contingency states are analyzed as part of the OPA.<sup>3</sup>
2. If the OPA identifies any potential exceedances, the RC and TOP must have an Operating Plan to address the exceedance.<sup>4</sup>
3. In Real-time, RCs and TOPs must perform Real-time Assessments (RTAs) at least once every 30 minutes to determine whether there are any expected or actual exceedances of SOLs (including IROLs) based on Real-time conditions.<sup>5</sup> The pre- and post-Contingency states are analyzed as part of the RTA.<sup>6</sup>
4. If SOL exceedances are observed in TOP Real-time monitoring or RTAs, TOPs are required to implement its Operating plan to mitigate the conditions.<sup>7</sup>
5. If SOL or IROL exceedances are observed in RC Real-time monitoring or RTAs, RCs are required to notify TOPs of those exceedances.<sup>8</sup>

---

<sup>1</sup> *Transmission Operations Reliability Standards and Interconnection Reliability Operations and Coordination Reliability Standards*, Order No. 817, 153 FERC ¶ 61,178 (2015).

<sup>2</sup> IRO-008-2, Requirement R1; TOP-004-2, Requirement R1.

<sup>3</sup> OPA – An evaluation of projected system conditions to assess anticipated (pre-Contingency) and potential (post-Contingency) conditions for next-day operations. The evaluation shall reflect applicable inputs including, but not limited to, load forecasts; generation output levels; Interchange; known Protection System and Special Protection System status or degradation; Transmission outages; generator outages; Facility Ratings; and identified phase angle and equipment limitations. (Operational Planning Analysis may be provided through internal systems or through third-party services.)

<sup>4</sup> IRO-008-2, Requirement R2; TOP-004-2, Requirement R2.

<sup>5</sup> IRO-008-2, Requirement R4; TOP-001-3, Requirement R13.

<sup>6</sup> RTA – An evaluation of system conditions using Real-time data to assess existing (pre-Contingency) and potential (post-Contingency) operating conditions. The assessment shall reflect applicable inputs including, but not limited to: load, generation output levels, known Protection System and Special Protection System status or degradation, Transmission outages, generator outages, Interchange, Facility Ratings, and identified phase angle and equipment limitations. (Real-time Assessment may be provided through internal systems or through third-party services.)

<sup>7</sup> TOP-001-3 requirement, Requirement R14

<sup>8</sup> IRO-008-2 requirement, Requirement R5



6. If there is an expected or actual IROL exceedance identified in RC Real-time monitoring or RTAs, the exceedance must be resolved within the IROL  $T_v$ , which can be no longer than 30 minutes.<sup>9</sup>

Pursuant to the construct in the currently-effective TOP/IRO Reliability Standards, TOPs and RCs must assess system conditions, identify expected or actual SOL exceedances (including for the subset of SOLs designated as IROLs) and take steps to address any such exceedances to avoid the possibility of further deterioration in system conditions. Under this new construct, the pre- and post-Contingency states are assessed on an ongoing basis as part of OPAs and RTAs. Any SOL exceedances that are observed are required to be mitigated per the respective Operating Plans. Under this new construct, it is the OPA, the RTA, and the implementation of Operating Plans that “provide” for reliable pre- and post-Contingency operations. In the former construct, operating within the TOP-provided SOL “provided” for reliable pre- and post-Contingency operations. The proposed revised FAC standards and the proposed revised SOL definition is intended to reflect the new construct depicted in the TOP and IRO standards.

## **NERC SOL Whitepaper**

As discussed in the whitepaper prepared by the SDT for Project 2014-03 Revisions to TOP and IRO Standards (the “Project 2014-03 Whitepaper”), which developed the currently-effective Transmission Operations (“TOP”) and Interconnection Reliability Operations and Coordination (“IRO”) Reliability Standards, while the term SOL is used extensively in the NERC Reliability Standards, there is significant confusion with, and many widely varied interpretations and applications of, the term SOL. While the Project 2014-03 SDT did not seek to modify the SOL definition, they drafted the Project 2014-03 Whitepaper to describe their understanding of the SOL term/concept and to “bring clarity and consistency to the notion of establishing SOLs, exceeding SOLs, and implementing Operating Plans to mitigate SOL exceedances.” The Project 2014-03 Whitepaper served as the conceptual basis for the development of the currently-effective TOP/IRO Reliability Standards.

As described in the Project 2014-03 Whitepaper, the central principles of the SOL concept in NERC’s Reliability Standards is to:

1. Know the Facility Ratings, voltage limits, transient Stability limits, and voltage Stability limits, and
2. Ensure that they are all observed in both the pre- and post-Contingency state by performing a Real-time Assessment.

These principles are reflective of the new construct for managing reliability for the pre- and post-Contingency state depicted in the TOP and IRO standards created as part of Project 2014-03.

Following the development of the currently-effective TOP/IRO Reliability Standards, NERC initiated a periodic review of the requirements in the Facilities Design, Connections, and Maintenance (“FAC”) group of Reliability Standards addressing SOLs. The periodic review team identified a need to revise or develop new definitions to be incorporated into the NERC Glossary to provide greater clarity and consistency in establishing SOLs and promote a common understanding of what it means to exceed SOLs. The periodic review team recognized that while the Project 2014-03 Whitepaper provided clarity on the SOL concept,

---

<sup>9</sup> IRO-009-2, Requirements R1-R4; TOP-001-3, Requirement R12.

reliability would be further enhanced by (1) revising the SOL definition in the NERC Glossary, and (2) developing a new defined term SOL Exceedance. The periodic review envisioned that these two enhancements help to better align the definitions in the NERC Glossary with the Project 2014-03 Whitepaper and better support the SOL exceedance concept used in the TOP/IRO Reliability Standards. Subsequently, to address the issues identified in the periodic review, NERC initiated Project 2015-09 to revise the requirements for, and definitions related to, the methodology used for establishing and communicating SOLs.

In September of 2017 the SDT posted a proposed definition of SOL Exceedance for informal comment. The industry responses to the draft SOL Exceedance definition indicated numerous significant concerns. Given these responses, the SDT concluded that creating a definition of SOL Exceedance that adequately reflected reliable operating principles could create too much of an unnecessary compliance burden without significant modification to the existing TOP and IRO standards. Therefore, the SDT abandoned the idea of creating a definition for SOL Exceedance in favor of addressing the performance criteria through requirements in FAC-011-4 and FAC-014-3 similar to the way it is done in the currently effective FAC standards.

## **Modifications to SOL Definition**

The Project 2015-09 SDT proposes to define the term System Operating Limit (SOL) as:

*All Facility Ratings, System Voltage Limits, and stability limits, applicable to specified System configurations, used in Bulk Electric System operations for monitoring and assessing pre- and post-Contingency operating states.*

The SDT's intent was to simplify and clarify the SOL definition by eliminating ambiguities such that SOLs are easily identifiable and easily measurable. The currently-effective SOL definition states that SOLs "are based upon certain operating criteria." The modified definition eliminates the phrase "are based upon" to more accurately state that the SOLs "are" the actual operating parameters which are to be observed for the pre- and post-Contingency states, leaving no confusion as whether a Facility Rating, stability limit, or voltage limit is an SOL. The unambiguous language in the modified definition should help facilitate a more consistent application of the SOL concept within the electric industry.

Facility Ratings, System Voltage Limits, and stability limits are the three types of operating criteria included in the existing SOL definition and carried forward into the modified definition that must be accounted for to ensure reliable operations. Facility Ratings must be established in accordance with Reliability Standard FAC-008-3. System Voltage Limits, as discussed below, is proposed to be defined as "the maximum and minimum steady-state voltage limits (both normal and emergency) that provide for acceptable System performance." Stability limits includes both transient stability limits and voltage stability limits. The intent of using the "stability limit" term (as opposed to the NERC Glossary term "Stability Limit") is to allow for a number of different types of stability-related limitations or phenomena, including, but not limited to, sub-synchronous resonance (SSR), phase angle limitations, transient voltage limitations on equipment, and weighted short-circuit ratio (WSCR). The Glossary term "Stability Limits" is not appropriate for use in the revised definition because its use is limited to a maximum power flow value. While some entities may use

maximum power flow values as a means by which to prevent instability, this approach represents only one particular method and may be too restrictive for some entities. Reliability tools allow entities to monitor and control parameters other than maximum power flow values in order to demonstrate acceptable stability performance.

Unlike the existing SOL definition, the proposed definition includes the phrase “used in Bulk Electric System operations” to distinguish those Facility Ratings, voltage limits, and stability limits that are used in planning. The SDT determined that the SOL concept should be limited to the operational time horizon and thus proposes to retire FAC-010-3. The Facility Ratings, voltage limits, and stability criteria used in the planning horizon are developed according to FAC-008-3 and TPL-001-4 and, as a result, there was no additional reliability need to require Planning Authorities to develop SOLs to be used in the planning horizon. The SDT concluded, however, that there was a reliability need to coordinate the Facility Ratings, voltage limits, and stability criteria used in planning with those used in operations. The SDT developed requirement R6 in proposed Reliability Standard FAC-014-3 to address that issue.

As discussed in detail below, the SDT determined that references to “most limiting criteria” and “acceptable reliability criteria”, and the manner in which the “specified system configuration” and the “pre- and post-contingency” phrases were used in the currently-effective definition of SOL were adding to industry confusion as to what constitutes an SOL.

Most limiting Criteria – The SDT concluded that removing the “most limiting criteria” concept in favor of designating all Facility Ratings, System Voltage Limits, and stability limits as SOLs is better aligned with the requirements in the TOP/IRO Reliability Standards. As noted above, under the TOP/IRO Reliability Standards, each RC and TOP must perform Operational Planning Analysis (OPAs) and Real-time Assessments (RTAs) to assess conditions in the day ahead and Real-time horizon and, if it identifies any actual, expected or potential SOL exceedance, take appropriate mitigating action to maintain pre- and post-Contingency reliable operations. Under the currently-effective SOL definition, RCs and TOPs must initially determine which operating parameter is the most limiting at that point in time to be designated as the SOL and then determine if there are any actual, potential, or expected exceedances of that SOL. The SDT understands that this has caused some confusion within industry. Specifically, it may be unclear in Real-time operations when an SOL ceases to be an SOL because it is no longer the “most limiting criteria.” Confusion is introduced when the most limiting criteria (and thus the SOL) changes from one RTA to the next.

The SDT determined that it is more straightforward to simply categorize all Facility Ratings, System Voltage Limits, and stability limits as SOLs. In performing OPAs and RTAs, RCs and TOPs should be assessing conditions as it relates to any operating parameter or reliability limit, not the most limiting parameter or limit based on a particular prior analysis. Under the new TOP and IRO requirements, RCs and TOPs are assessing conditions on an ongoing basis through OPAs and RTAs to determine whether there are any actual, potential, or expected exceedances of any Facility Rating, System Voltage Limit, or stability limit, which would necessarily include the most limiting of those parameters/limits. In this manner, the “most limiting criteria” concept is subsumed within the requirements of the TOP/IRO Reliability Standards and it is not necessary that it be included in the SOL definition. In short, the proposed SOL definition creates a simplified approach. There is no need to continuously identify and communicate the ever-changing “most

limiting” criteria. Entities must simply operate – and plan to operate – to prevent any exceedance of all Facility Ratings, System Voltage Limits, and stability limits.

The SDT determined that the removal of the “most limiting criteria” from the SOL definition represents an improvement to reliability. The “most limiting criteria” can adversely impact reliability by masking instability risks that may exist slightly beyond the point of the most limiting condition. To illustrate, where prior studies indicate that a thermal limitation is the “most limiting criteria,” if the studying entity does not study the performance of the system appreciably beyond this thermal limitation to reasonably expected stressed conditions, it cannot be safely concluded that a more significant instability risk does not exist slightly beyond the point where the “most limiting criteria” exists. Because actions may be taken in the actual system conditions that mitigate thermal and voltage limitations identified as a “most limiting criteria”, it may be necessary to identify where subsequent operation may approach a point of instability. Consistent with this concept, the RC and its TOPs have the responsibility of establishing stability limits in accordance with the Reliability Coordinator’s SOL Methodology, as required by FAC-011-4 Requirement R4 and FAC-014-3 Requirements R2 and R4.

Acceptable Reliability Criteria – The SDT determined that the “acceptable reliability criteria” concept is best addressed through requirement language and that the SOL definition should focus simply on what constitutes an SOL. Taken together, the operations performance criteria in FAC-011-4 requirement R6 and the corresponding requirement R7 in FAC-014-3 adequately addresses operation within acceptable reliability criteria.

Specified System Configuration – The SDT proposes to retain the reference to “specified system configuration” due to the fact that stability limits in particular are typically dependent on system configuration. While Facility Ratings and System Voltage Limits are not typically dependent upon system configuration, there may be times where they may be dependent on System configuration. For example, if a transmission line is connected by two circuit breakers at one end of the line, and one of those two circuit breakers is open, the value of the Facility Rating for line could be reduced due to current carrying capability of the remaining in-service circuit breaker.

Pre- and Post-Contingency – The currently effective SOL definition specifies that each of the listed operating limit types are applicable for both the pre- and post-Contingency states. The SDT determined that the pre- and post-Contingency concept needed to be retained; however, it should be used in a manner consistent with the construct depicted in the new TOP and IRO standards rather than the old construct where the SOL itself “provided” for pre- and post-Contingency acceptable performance. The proposed definition makes it clear that both the pre-Contingency state and the post-Contingency state must be considered when evaluating the System performance for Facility Ratings, System Voltage Limits, and stability limits. As OPAs and RTAs are the mechanisms in the Reliability Standards for determining potential SOL exceedances (OPA) and actual SOL exceedances (RTA),<sup>10</sup> the definition of SOL should support the concept that both the pre- and post-Contingency states should be accounted for.

---

<sup>10</sup> In Order No. 705 (at P 162), the Commission stated that system performance is determined through studies, stating “the Commission believes that to demonstrate the pre- and post-contingency performance metrics required by [FAC-010-1] Requirements R2.1-R2.2 an

One aspect of the improved clarity of the revised definition of SOL is seen in its intended use. Under the revised definition, SOLs are intended to be used as an input into the OPA and RTA process.<sup>11</sup> The OPA and RTA process itself examines SOLs for the pre- and post-Contingency states and determines whether the SOLs are being exceeded. Accordingly, while SOLs are an input to the OPA and RTA process, SOL exceedance is the output of the OPA and RTA process. FAC-014-3 requirement R7 effectively stipulates that the operations performance criteria denoted in FAC-011-4 requirement R6 must be used in OPAs, RTAs, and Real-time monitoring when identifying SOL exceedances.

Lastly, as with the currently-effective SOL definition, the proposed SOL definition does not include reference to IROLs. IROLs, as currently defined, are a subset of SOLs that, if exceeded, “could lead to instability, uncontrolled separation, or Cascading outages that adversely impact the reliability of the BES.” The determination of when an SOL should be designated as an IROL is most appropriately addressed in the RC’s SOL methodology. There is no need to mention IROLs in the definition of SOL.

---

assessment or analysis would need to be performed. As such, Requirements R2.1-R2.2 provide for actions that go beyond NERC’s characterization of the subject of the requirements as limited to a list of topics that must be included in a methodology. Therefore, we conclude that these Requirements are more Docket No. RM07-3-000 - 79 - properly treated as implementation or operational requirements that may have a direct impact on reliability.”

<sup>11</sup> Some Reliability Coordinators and Transmission Operators may establish stability limits in the context of an OPA or RTA. For entities who adopt this approach, the stability SOL would be established – and its exceedance determined – as part of the OPA or RTA.

Exhibit C-6

Technical Rationale  
System Voltage Limit Definition

# Proposed Definition of “System Voltage Limit”

## Term: “System Voltage Limit”

### Definition:

The maximum and minimum steady-state voltage limits (both normal and emergency) that provide for acceptable System performance.

### Rationale

As noted above, the Project 2015-09 standard drafting team (SDT) also proposes to add the term System Voltage Limit to the NERC Glossary with the following definition:

*The maximum and minimum steady-state voltage limits (both normal and emergency) that provide for acceptable System performance.*

The SDT identified a need to develop a NERC Glossary definition for the term System Voltage Limit to address confusion within industry as to what constitutes a system voltage limit. As part of its informal comment period on initial drafts of FAC-011-4 and FAC-014-3 (July 14- August 12, 2016), the SDT requested industry comment on whether there is a need to clarify what constitutes system voltage limits through a defined term in the NERC Glossary. The SDT proposed the following definition: “The maximum and minimum steady-state voltages (both Normal and Emergency) that provide for reliable system operations.”

The vast majority of commenters indicated support for developing a definition for System Voltage Limits but noted a few concerns with the proposed definition. In response to those comments, the SDT made the following revisions:

- The word “limits” was added to clarify that it is a numeric value.
- The terms “Normal” and “Emergency” were changed to lower case as “Normal” is not defined in the NERC Glossary, and the SDT concluded that the NERC defined term “Emergency” was not appropriate.
- The phrase “reliable system operations” was replaced with “acceptable System performance” because the SDT determined that this language was more reflective of the desired intent behind the definition.
- The SDT used the NERC Glossary term “System” as the definition implies that System Voltage Limits should result in acceptable performance (from a voltage perspective) of the overall System.

The proposed System Voltage Limit definition does not specify whether the Transmission Operator would be required to provide a “System Voltage Limit” for each bus on its system, or if the Transmission Operator would need to provide a single high and low limit that is applicable to its entire system. The SDT intends for



the Reliability Coordinator's System Operating Limits (SOL) Methodology to dictate the manner in which System Voltage Limits should be established. The proposed definition allows Reliability Coordinators to have such flexibility, provided the requirements in proposed FAC-011-4 are met.

Additionally, the System Voltage Limit definition allows for differing time components that may be associated with short term or dynamic ratings. The SDT's intent is to allow the flexibility to establish System Voltage Limits consistent with the Reliability Coordinator's SOL Methodology, provided the requirements in proposed FAC-011-4 are met. The proposed definition specifies that System Voltage Limits must include normal and emergency maximum and minimum limits, and that these limits provide for acceptable System performance (in the context of voltage performance). According to the definition, it is acceptable for a Reliability Coordinator's SOL Methodology to allow for System Voltage Limits to include a normal limit and multiple emergency limits, which may have associated time values similar to the way emergency Facility Ratings are associated with time values. As discussed below, this concept is supported by the proposed definition of SOL Exceedance which states, in relevant part: "Bus voltage is outside the highest or lowest emergency System Voltage Limit, or outside a System Voltage Limit for which there is not sufficient time to bring the bus voltage to defined levels should the Contingency occur

Lastly, the proposed definition of System Voltage Limit does not explicitly distinguish between a voltage limit and a voltage rating. That is because proposed FAC-011-4 requires that System Voltage Limits respect equipment voltage ratings.

### **Potential Standards for Use of New Term: "System Voltage Limit"**

These standard(s) were identified as potential areas that may benefit from the use of the new term. The SDT is in the process of evaluating these standards with respect to incorporating the definition.

- FAC-003-4 Transmission Vegetation Management
- MOD-001-2 Available Transmission System Capability
- PRC-012-2 Remedial Action Schemes
- TPL-001-4 Transmission System Planning Performance Requirements
- TPL-007-1 Transmission System Planned Performance for Geomagnetic Disturbance Events
- VAR-001-4.1 Voltage and Reactive Control



Exhibit C-7

Technical Rationale  
Exclusion of CIP Criteria Modifications

# Technical Rationale for Exclusion of CIP Criteria Modifications by Project 2015-09

February 2021

## Introduction

The Project 2015-09 Standard Drafting Team (SDT) is proposing the retirement of the NERC FAC-010-3 - System Operating Limits Methodology for the Planning Horizon Reliability Standard. The SDT further proposes a new construct regarding the coordination of the Planning Assessment (TPL-001-4 - Transmission System Planning Performance Requirements) with the establishment of System Operating Limits (SOLs) used in operations. Along with the retirement of FAC-010-3, this new construct consists of substantial modifications to FAC-011-3 - System Operating Limits Methodology for the Operation Horizon and FAC-014-2 - Establish and Communicate System Operating Limits. These proposals together represent an improvement for planning and operations to better coordinate analysis input assumptions and System performance criteria to prevent instability, Cascading or uncontrolled separation that adversely impact the reliability of the BES up to and including Real-time operations.

The proposed construct does not make use of an SOL methodology applicable to the planning horizon as required by the currently-effective FAC-010-3 due to its overall redundancy with TPL-001-4, and potential conflicts with the Reliability Coordinator's (RC) SOL methodology. During their discussion of FAC-010-3's retirement, the SDT concluded (with industry concurrence) that SOLs, and Interconnection Reliability Operating Limit (IROLs), only appropriate in the operations time horizon, and should not be determined in the planning horizon.

With these proposed changes to the FAC standards, and this conclusion regarding SOLs, the SDT was tasked with ensuring supplemental modifications were made, where necessary, to other Reliability Standards that made use of or referred to planning horizon SOLs. However, CIP-002-5.1a - Cyber Security — BES Cyber System Categorization and CIP-014-2 - Physical Security are not among the modification proposals despite the references, in attachments/applicability sections, to Planning Coordinator (PC)/Transmission Planner (TP) derived IROLs for use in the planning horizon. The remainder of this document provides a rationale for the SDT's exclusion of these two standards from the overall proposed modifications that result from the proposed retirement of FAC-010-3.

## CIP Requirements for PC/TP Input

### CIP-002.5.1a

Reliability Standard CIP-002.5.1a includes an attachment providing criteria that characterize the level of impact of CIP assets. The attachment includes 13 criteria (2.1 through 2.13) for the medium level. The first eight (8) criteria (2.1 through 2.8) focus on sets of transmission and generation facilities.

Criterion 2.6 in Attachment 1 of the standard states:

*Generation at a single plant location or Transmission Facilities at a single station or substation location that are identified by its Reliability Coordinator, Planning Coordinator, or Transmission Planner as critical to the derivation of Interconnection Reliability Operating Limits (IROLs) and their associated contingencies.*

Upon the retirement of FAC-010, this information would still be available from the RC via that information provided due to FAC-014 R5.6, but there would be no direct tie to PC/TP derived IROLs. The SDT does not view the retirement of FAC-010 as a potential reliability gap as it related to this criterion for the following reasons.

- The RC is currently solely responsible for determining IROLs needed for operating the BES reliably. Those IROLs exist for use by the RC and are shared with their Transmission Operators (TOPs). This does not change with the new SOL construct the SDT is proposing. In the new construct, the RC will continue to provide its IROLs to its TOPs and impacted planning entities. Additionally, the RC will provide information to the transmission and generation asset owners for their Facilities that are critical to the derivation of an IROL or its critical contingencies, at least annually. This ensures that all *“Generation at a single plant location or Transmission Facilities at a single station or substation location that are identified ... as critical to the derivation of Interconnection Reliability Operating Limits (IROLs) and their associated contingencies”* are addressed with no gaps.
- Also in this new construct, PCs and TPs will continue to conduct their respective planning assessments in accordance with TPL-001 to identify system deficiencies and the respective Corrective Action Plans (CAPs) to address them. PCs and TPs will share with impacted RCs any information on CAPs they determine are needed to correct instances of instability found in their Planning Assessment of the Near-Term Transmission Planning Horizon (proposed FAC-014-3, Requirement R7). This provides the RC additional relevant information it needs from planning entities in its determination of SOLs, including IROLs. This ensures that all *“Generation at a single plant location or Transmission Facilities at a single station or substation location that are identified ... as critical to the derivation of Interconnection Reliability Operating Limits (IROLs) and their associated contingencies”* include relevant input from the PC/TPs.
- Criterion 2.3 references generation Facilities identified by the PC/TP as necessary to avoid an Adverse Reliability Impact. This has significant overlap, as it relates to generation Facilities, to the Facilities that would also be identified by the RC as critical to the derivation of an IROL. It is important to note that the actual operating limit (referenced in criterion 2.6) is not the focus. Rather, the identification of the relevant generation plant is the focus; this plant, if lost or

somehow compromised, could adversely impact the BES. This would also produce significant overlap to the Facilities identified by the RC in Criterion 2.6.

- Criterion 2.4 automatically qualifies Transmission Facilities operated at 500 kV or greater voltages to be in the medium impact category. This is regardless the reliability impact of a specific Facility that could be identified by planning studies. Since these types of Facilities enable bulk power flow of the System, the impact identified by planning studies of the loss of one or more of these Facilities would generally produce more severe impacts than lower voltage Facilities. This would also produce significant overlap to the Facilities identified by the RC in Criterion 2.6.
- Criterion 2.5 automatically qualifies Facilities operating between 200 kV and 499 kV based on the number of connections to other Transmission stations or substations. The basic premise in this criterion is to include “well-connected” BES substations as medium impact Facilities. Since these types of Facilities enable bulk power flow of the System, the impact identified by planning studies of the loss of one or more of these Facilities would generally produce more severe impacts than Facilities not as well connected to the System. This would also produce significant overlap to the Facilities identified by the RC in Criterion 2.6.
- TPL-001-4 Requirement R3 Parts 3.4 and 3.5 and Requirement R4 Parts 4.4 and 4.5 require the PC/TP to, in the annual Planning Assessment, identify and create a list of the planning and extreme events that are expected to produce “more severe System impacts.” These events may overlap those events that are critical to the derivation of an IROL. The transmission/generation owners can receive the annual Planning Assessment by request as a “functional entity with a reliability related need” per Requirement R8 of the standard.
- Proposed FAC-014-3 requires the PC/TP to annually communicate to impacted Transmission Owners and Generation Owners “their Facilities that comprise the planning event Contingency(ies) that would cause instability, Cascading or uncontrolled separation that adversely impacts the reliability of the BES as identified in its Planning Assessment of the Near-Term Transmission Planning Horizon.” This list of Facilities (for specific owners), covers all facilities the PC/TP would identify as critical to the derivation of an IROL under FAC-014-2 as it utilizes the components of the IROL definition (instability, Cascading, and uncontrolled separation that adversely impact the reliability of the Bulk Electric System) to describe the relevant Facilities as opposed to using the term itself.

In addition, the information provided by the RCs per FAC-014 R5.6 will be made available annually to the facility owners. Today there is no requirement that the information described in attachment 1 of CIP-002.5.1a be provided by any entity. FAC-014 R5.6 identifies an entity (the RC) and requires the information be submitted on regular basis (at least once annually). The annual submission requirement should address the concern noted by FERC in order 777 regarding the timeliness of CIP information provision. With an annual submission, the parties submitting the data should be able to provide the required information whether the data is created in an annual process (such as seasonal studies), or some other effort with a higher periodicity. The information recipients, the CIP asset owners, should be able to budget, plan and execute necessary projects accordingly knowing that they will receive the required

information annually. If the RC deems an increased periodicity is needed, they can so act, but annual requirement set the minimum standard that all entities can use.

### **CIP-014-2**

Reliability Standard CIP-014-2 enumerates the criteria (4.1.1.1 – 4.1.1.4) for Transmission Facilities to require physical security hardening. These criteria overlap those referenced above in CIP-002-5.1a.

Criterion 4.1.1.3 in the Applicability section of the standard states:

*Transmission Facilities at a single station or substation location that are identified by its Reliability Coordinator, Planning Coordinator, or Transmission Planner as critical to the derivation of Interconnection Reliability Operating Limits (IROLs) and their associated contingencies.*

This criterion is very similar to criterion 2.6 in CIP-002-5.1a as it relates to transmission facilities. Due to the similarities in the criteria, the same rationale stated for CIP-002-5.1a applies to CIP-014-2.

Exhibit D-1

Mapping Document  
FAC-010-3

## Mapping Document for FAC-010-3

### Project 2015-09 Establish and Communicate System Operating Limits

The Project 2015-09 standard drafting team (SDT) is proposing the retirement of the NERC FAC-010-3 Reliability Standard. The SDT further proposes a new paradigm regarding the coordination of the Planning Assessment (TPL-001-4) with the establishment of System Operating Limits (SOLs) used in operations. Along with the retirement of FAC-010-3, this new paradigm consists of revisions to the existing FAC-011-3 and FAC-014-2 Reliability Standards. The SDT's proposed revisions contained in FAC-011-4 and FAC-014-3 represent an improvement for planning and operations to better coordinate analysis input assumptions and System performance criteria to address the reliability issues that are ultimately faced in Real-time operations.

The proposed construct does not make use of an SOL methodology applicable to the planning horizon as required by the currently-effective FAC-010-3 due to its overall redundancy with TPL-001-4. However, FAC-014-3, Requirement R7 is intended to provide a mechanism for Planning Assessments performed for the Near-Term Transmission Planning Horizon, are bounded by modeling data and performance criteria that are equally limiting or more limiting than those established in accordance with the Reliability Coordinator's (RC's) SOL methodology. FAC-014-3, Requirement R7 addresses Facility Ratings, System steady state voltage limits, and stability performance criteria used in the development of Planning Assessments. Therefore, this requirement focuses on the three components of SOLs used in operations and facilitates continuity between operations and planning. Implementing the process required in FAC-014-3 Requirement R7 ensures Planning Coordinators (PC) and Transmission Planners (TP) use, or provide a technical rationale why they don't use Facility Ratings, System steady-state voltage limits, and stability performance criteria that are equally limiting or more limiting than the Facility Ratings, System Voltage Limits, and stability performance criteria established in accordance with the Reliability Coordinator's SOL methodology.

FAC-014-3, Requirement R8 requires PCs and TPs to communicate pertinent information on Corrective Action Plans (CAP) developed to address any instability identified in Planning Assessments of the Near-Term Transmission Planning Horizon to the RC and to impacted Transmission Operators (TOPs). This information may be useful to RCs and TOPs in the establishment of stability limits and IROLs that will ultimately be used in Real-time operations.

By implementing Requirements R7 and R8 of FAC-014-3, Facility Ratings, System steady-state voltage limits and stability criteria used in the development of the Planning Assessment of the Near-Term Transmission Planning Horizon are effectively bounded by the Facility Ratings, System Voltage Limits, and stability performance criteria define and established in accordance with the RC's SOL methodology (FAC-011-4). Furthermore, potentially critical stability information is communicated by planners to operators resulting an improvement in reliability by increasing continuity between planning and operations not currently provided for in the existing body of NERC Reliability Standards.

The remainder of this document provides a mapping of the existing requirements in FAC-010-3 to the proposed action by the SDT. For easier reference applicable information from Table 1 of TPL-001-4 is included below. References to notes a – j and Planning Events P0 – P7 will be included in the mapping table where appropriate.

**TPL-001-4 Table 1 (steady state & stability performance criteria notes for planning events) Steady State & Stability:**

- a. The System shall remain stable. Cascading and uncontrolled islanding shall not occur.
- b. Consequential Load Loss as well as generation loss is acceptable as a consequence of any event excluding P0.
- c. Simulate the removal of all elements that Protection Systems and other controls are expected to automatically disconnect for each event.
- d. Simulate Normal Clearing unless otherwise specified.
- e. Planned System adjustments such as Transmission configuration changes and re-dispatch of generation are allowed if such adjustments are executable within the time duration applicable to the Facility Ratings.

**Steady State Only:**

- f. Applicable Facility Ratings shall not be exceeded.
- g. System steady state voltages and post-Contingency voltage deviations shall be within acceptable limits as established by the Planning Coordinator and the Transmission Planner.
- h. Planning event P0 is applicable to steady state only.
- i. The response of voltage sensitive Load that is disconnected from the System by end-user equipment associated with an event shall not be used to meet steady state performance requirements.



**Stability Only:**

- j. Transient voltage response shall be within acceptable limits established by the Planning Coordinator and the Transmission Planner.

**Category P0 No Contingency**  
(Initial Condition - Normal System)

**Category P3 Multiple Contingency**  
(Initial Condition - Loss of generator unit followed by System adjustments)

Loss of one of the following:

1. Generator (3 Ø fault)
2. Transmission Circuit (3 Ø fault)
3. Transformer (3 Ø fault)
4. Shunt Device (3 Ø fault)
5. Single Pole of DC line (SLG fault)

**Category P6 Multiple Contingency**  
(Initial Condition - Loss of one of the following followed by System adjustments.

1. Transmission Circuit
2. Transformer
3. Shunt Device
4. Single Pole of DC line)

Loss of one of the following:

1. Transmission Circuit (3 Ø fault)
2. Transformer (3 Ø fault)
3. Shunt Device (3 Ø fault)
4. Single Pole of DC line (SLG fault)

**Category P1 Single Contingency**  
(Initial Condition - Normal System)

Loss of one of the following:

1. Generator (3 Ø fault)
2. Transmission Circuit (3 Ø fault)
3. Transformer (3 Ø fault)
4. Shunt Device (3 Ø fault)
5. Single Pole of DC line (SLG fault)

**Category P4 Multiple Contingency**  
(Initial Condition - Normal System)

1. Generator (SLG fault)
2. Transmission Circuit (SLG fault)
3. Transformer (SLG fault)
4. Shunt Device (SLG fault)
5. Bus Section (SLG fault)
6. Loss of multiple elements caused by a stuck breaker (Bus-tie Breaker) attempting to clear a Fault on the associated bus

**Category P7 Multiple Contingency**  
(Initial Condition - Normal System)

The loss of:

- Any two adjacent (vertically or horizontally) circuits on common structure (SLG fault)
- Loss of a bipolar DC line (SLG fault)

**Category P2 Single Contingency**  
(Initial Condition - Normal System)

1. Opening of a line section w/o a fault
2. Bus Section Fault (SLG fault)
3. Internal Breaker Fault (non-Bus-tie Breaker) (SLG fault)
4. Internal Breaker Fault (Bus-tie Breaker) (SLG fault)

**Category P5 Multiple Contingency**  
(Initial Condition - Normal System)

Delayed Fault Clearing due to the failure of a non-redundant relay protecting the Faulted element to operate as designed, for one of the following:

Generator (SLG fault)

1. Transmission Circuit (SLG fault)
2. Transformer (SLG fault)
3. Shunt Device (SLG fault)
4. Bus Section (SLG fault)

**Standard: FAC-010-3 — System Operating Limits Methodology for the Planning Horizon**

Requirement in Approved Standard	Translation to New Standard or Other Action	Description and Change Justification
<p><b>R1.</b> The Planning Authority shall have a documented SOL Methodology for use in developing SOLs within its Planning Authority Area. This SOL Methodology shall:</p>	<p><b>FAC-010-3, Requirement R1 is addressed by:</b></p> <ol style="list-style-type: none"> <li>1. TPL-001-4, Requirements R1, R5, and R6</li> <li>2. MOD-032-1, Requirement R2</li> <li>3. FAC-008-3 Requirements R2 and R3</li> </ol> <p><b>TPL-001-4, Requirement R1:</b></p> <p><b>R1.</b> Each Transmission Planner and Planning Coordinator shall maintain System models within its respective area for performing the studies needed to complete its Planning Assessment. The models shall use data consistent with that provided in accordance with the MOD-010 and MOD-012 standards, supplemented by other sources as needed, including items represented in the Corrective Action Plan, and shall represent projected System conditions. This establishes Category P0 as the normal System condition in Table 1.</p> <p><b>R1.1</b> System models shall represent:</p> <ul style="list-style-type: none"> <li><b>R1.1.1.</b> Existing Facilities</li> <li><b>R1.1.2.</b> Known outage(s) of generation or Transmission</li> </ul>	<p>SOLs developed by the PC and TP for use in the planning horizon are addressed in other standards as described below. SOLs used in the Operations Planning, Same-day Operations, and Real-time Operations time horizons are developed in accordance with the RC's methodology as specified in FAC-011-4.</p> <p>The determination of Facility Ratings, System steady-state voltage limits, and stability performance criteria for use in the Long-term Planning time horizon are addressed as follows. It is important to note the new FAC-014-3 Requirement R7 Reliability Standard bounds the following items as stated in the introduction of this document.</p> <p><b>Facility Ratings</b></p> <p>PCs and TPs are required, by TPL-001-4 Requirement R1, to maintain System models and to use data consistent with that which has been provided in accordance with MOD-032-1 (which supersedes the MOD-010 and MOD-012 standards). Facility Ratings are included in this data. These Facility Ratings:</p> <ul style="list-style-type: none"> <li>• Are determined in accordance with a Generator Owner's (GOs) or TO's Facility Ratings Methodology as required by FAC-008-3 R2 &amp; R3 and</li> </ul>

**Standard: FAC-010-3 — System Operating Limits Methodology for the Planning Horizon**

Requirement in Approved Standard	Translation to New Standard or Other Action	Description and Change Justification
	<p>Facility(ies) with a duration of at least six months.</p> <p><b>R1.1.3.</b> New planned Facilities and changes to existing Facilities</p> <p><b>R1.1.4.</b> Real and reactive Load forecasts</p> <p><b>R1.1.5.</b> Known commitments for Firm Transmission Service and Interchange</p> <p><b>R1.1.6.</b> Resources (supply or demand side) required for Load</p> <p><b>TPL-001-4, Requirement R5:</b>  <b>R5.</b> Each Transmission Planner and Planning Coordinator shall have criteria for acceptable System steady state voltage limits, post-Contingency voltage deviations, and the transient voltage response for its System. For transient voltage response, the criteria shall at a minimum, specify a low voltage level and a maximum length of time that transient voltages may remain below that level.</p> <p><b>TPL-001-4, Requirement R6:</b>  <b>R6.</b> Each Transmission Planner and Planning Coordinator shall define and document,</p>	<ul style="list-style-type: none"> <li>• Are provided to the PC and TP by the Facility Owner as required by MOD-032-1 R2.</li> </ul> <p><b>System Steady-State Voltage Limits</b></p> <p>TPL-001-4 R5 requires the TP and PC to have criteria for acceptable System steady state voltage limits. These limits are used in the Planning Assessments.</p> <p><b>Transient and Voltage Stability Performance Criteria</b></p> <p>TPL-001-4 Requirement R6 requires the TP and PC to have documented criteria to identify system conditions such as Cascading, voltage instability, or uncontrolled islanding. This criteria is applied when performing Planning Assessments to identify instances of Cascading, voltage instability, or uncontrolled islanding.</p>

**Standard: FAC-010-3 — System Operating Limits Methodology for the Planning Horizon**

Requirement in Approved Standard	Translation to New Standard or Other Action	Description and Change Justification
	<p>within their Planning Assessment, the criteria or methodology used in the analysis to identify System instability for conditions such as Cascading, voltage instability, or uncontrolled islanding.</p> <p><b>MOD-032-1, Requirement R2:</b>  <b>R2.</b> Each Balancing Authority, Generator Owner, Load Serving Entity, Resource Planner, Transmission Owner, and Transmission Service Provider shall provide steady-state, dynamics, and short circuit modeling data to its Transmission Planner(s) and Planning Coordinator(s) according to the data requirements and reporting procedures developed by its Planning Coordinator and Transmission Planner in Requirement R1. For data that has not changed since the last submission, a written confirmation that the data has not changed is sufficient.</p> <p><b>FAC-008-3, Requirement R2:</b>  <b>R2.</b> Each Generator Owner shall have a documented methodology for determining Facility Ratings (Facility Ratings methodology) of its solely and jointly owned equipment connected between the location specified in R1 and the point of</p>	

Standard: FAC-010-3 — System Operating Limits Methodology for the Planning Horizon		
Requirement in Approved Standard	Translation to New Standard or Other Action	Description and Change Justification
	interconnection with the Transmission Owner that contains all of the following...  <b>FAC-008-3, Requirement R3:</b> <b>R3.</b> Each Transmission Owner shall have a documented methodology for determining Facility Ratings (Facility Ratings methodology) of its solely and jointly owned Facilities (except for those generating unit Facilities addressed in R1 and R2) that contains all of the following...	
<b>R1.1.</b> Be applicable for developing SOLs used in the planning horizon.		The proposed construct as described in the document introduction does not make use of an SOL methodology applicable to the planning horizon or the development of SOLs in accordance with the PC’s SOL methodology. The requirements from TPL-001-4, MOD-032-1, and FAC-008-3 discussed above are applicable to the Long-term Planning time horizon and supersede the need for developing planning horizon SOLs.
<b>R1.2.</b> State that SOLs shall not exceed associated Facility Ratings.	<b>TPL-001-4 Table1:</b> <b>Note: ‘f’</b>	The proposed construct as described in the document introduction does not make use of an SOL methodology applicable to the planning horizon or the development of SOLs in accordance with the PC’s SOL methodology.  TPL-001-4 is constructed such that a Corrective Action Plan is developed to address those conditions where Facility Ratings are forecasted

**Standard: FAC-010-3 — System Operating Limits Methodology for the Planning Horizon**

Requirement in Approved Standard	Translation to New Standard or Other Action	Description and Change Justification
		to be exceeded in response to a planning event. The implementation of the Corrective Action Plan ensures the System is planned so there are no exceedances of Facility Ratings.
<p><b>R1.3.</b> Include a description of how to identify the subset of SOLs that qualify as IROLs.</p>	<p><b>TPL-001-4, Requirement R6:</b>  <b>R6.</b> Each Transmission Planner and Planning Coordinator shall define and document, within their Planning Assessment, the criteria or methodology used in the analysis to identify System instability for conditions such as Cascading, voltage instability, or uncontrolled islanding.</p>	<p>The proposed construct as described in the document introduction does not make use of an SOL methodology applicable to the planning horizon or the development of IROLs in accordance with the PC’s SOL methodology. In the proposed construct, PCs and TPs develop Planning Assessments effectively bound by the RC’s SOL methodology. These Planning Assessments then identify instances of instability, Cascading, or uncontrolled separation per the criteria developed in TPL-001-4 and communicate those instances to the Reliability Coordinator via the distribution of the Planning Assessments (in accordance with IRO-017-1 Requirement R3)</p> <p>TPL-001-4, Requirement R6 requires PC and TPs to document criteria or a methodology for use in identifying Cascading, voltage instability, or uncontrolled islanding in the analysis conducted for the annual Planning Assessment. This criterion addresses the conditions described in the definition for Interconnection Reliability Operating Limit (IROL).</p>

<p><b>R2.</b></p>	<p>The Planning Authority's SOL Methodology shall include a requirement that SOLs provide BES</p>	<p><b>TPL-001-4 Table 1</b></p>	<p>The proposed construct as described in the document introduction does not make use of an SOL methodology applicable to the planning</p>
-------------------	---	---------------------------------	--



**Standard: FAC-010-3 — System Operating Limits Methodology for the Planning Horizon**

Requirement in Approved Standard	Translation to New Standard or Other Action	Description and Change Justification
<p>performance consistent with the following:</p>		<p>horizon. The SDT proposes retiring Requirement R2 and its subparts due to redundancy with TPL-001-4 performance requirements contained in Table 1 notes a – j. The TPL-001-4 criteria provide the performance criteria for studies within the planning horizon that serve as the basis of the annual Planning Assessment the standard requires the PC and TP produce.</p>
<p><b>R2.1.</b> In the pre-contingency state and with all Facilities in service, the BES shall demonstrate transient, dynamic and voltage stability; all Facilities shall be within their Facility Ratings and within their thermal, voltage and stability limits. In the determination of SOLs, the BES condition used shall reflect expected system conditions and shall reflect changes to system topology such as Facility outages.</p>	<p><b>TPL-001-4 Table1:</b> <b>Notes: ‘a’, ‘f’, ‘g’</b></p> <p><b>TPL-001-4, Requirement R1:</b> <b>R1.</b> (refer to Requirement R1 section above)</p>	<p>Pre-contingency (Category P0) Bulk Electric System (BES) planned performance is addressed by TPL-001-4 Table 1 with notes a, f, and g specifying the applicable performance criteria. BES planned performance is based on expected system conditions and changes to system topology such as Facility outages as specified in TPL-001-4 Requirement R1.</p>
<p><b>R2.2.</b> Following the single Contingencies<sup>1</sup> identified in</p>	<p><b>TPL-001-4 Table1:</b> <b>Notes: ‘a’, ‘f’, ‘g’</b></p>	<p>Single contingency (Categories P1 &amp; P2) BES planned performance is addressed by TPL-001-4</p>

<sup>1</sup> The Contingencies identified in R2.2.1 through R2.2.3 are the minimum contingencies that must be studied but are not necessarily the only Contingencies that should be studied.

Standard: FAC-010-3 — System Operating Limits Methodology for the Planning Horizon		
Requirement in Approved Standard	Translation to New Standard or Other Action	Description and Change Justification
Requirement 2.2.1 through Requirement 2.2.3, the system shall demonstrate transient, dynamic and voltage stability; all Facilities shall be operating within their Facility Ratings and within their thermal, voltage and stability limits; and Cascading or uncontrolled separation shall not occur.		Table 1 with notes a through j specifying the applicable performance criteria.
<p><b>R2.2.1.</b> Single line to ground or three-phase Fault (whichever is more severe), with Normal Clearing, on any Faulted generator, line, transformer, or shunt device.</p>	<p><b>TPL-001-4 Table1:</b> <b>Note: 'd'</b></p> <p><b>TPL-001-4 Table 1:</b> Categories P1 &amp; P2 Single Contingency Events</p> <p><b>TPL-001-4 Table 1:</b> <b>Footnote 2.</b> Unless specified otherwise, simulate Normal Clearing of faults. Single line to ground (SLG) or three-phase (3<math>\emptyset</math>) are the fault types that must be evaluated in Stability simulations for the event described. A 3<math>\emptyset</math> or a double line to ground fault study indicating the criteria are being met is sufficient evidence that a SLG condition would also meet the criteria.</p>	

**Standard: FAC-010-3 — System Operating Limits Methodology for the Planning Horizon**

Requirement in Approved Standard	Translation to New Standard or Other Action	Description and Change Justification
<b>R2.2.2.</b> Loss of any generator, line, transformer, or shunt device without a Fault.	<b>TPL-001-4 Table1:</b> Categories P1 & P2 Single Contingency Events	
<b>R2.2.3.</b> Single pole block, with Normal Clearing, in a monopolar or bipolar high voltage direct current system.	<b>TPL-001-4 Table1:</b> Categories P1 & P2 Single Contingency Events	
<b>R2.3.</b> Starting with all Facilities in service, the system’s response to a single Contingency, may include any of the following:	<b>TPL-001-4 Table 1</b>	Allowable actions for BES planned performance in response to single contingencies are addressed in approved TPL-001-4 Table 1, including Consequential Load Loss and System Reconfiguration.
<b>R2.3.1.</b> Planned or controlled interruption of electric supply to radial customers or some local network customers connected to or supplied by the Faulted Facility or by the affected area.	<b>TPL-001-4 Table1:</b> <b>Note: ‘b’</b>	
<b>R2.3.2.</b> System reconfiguration through manual or automatic control or protection actions.	<b>TPL-001-4 Table1:</b> <b>Note: ‘e’</b>	
<b>R2.4.</b> To prepare for the next Contingency, system adjustments may be made,	<b>TPL-001-4 Table1:</b> <b>Note: ‘e’</b>	

Standard: FAC-010-3 — System Operating Limits Methodology for the Planning Horizon		
Requirement in Approved Standard	Translation to New Standard or Other Action	Description and Change Justification
including changes to generation, uses of the transmission system, and the transmission system topology.	<p><b>TPL-001-4 Table 1:</b> Footnote 9. An objective of the planning process should be to minimize the likelihood and magnitude of interruption of Firm Transmission Service following Contingency events. Curtailment of Firm Transmission Service is allowed both as a System adjustment (as identified in the column entitled ‘Initial Condition’) and a corrective action when achieved through the appropriate re-dispatch of resources obligated to re-dispatch, where it can be demonstrated that Facilities, internal and external to the Transmission Planner’s planning region, remain within applicable Facility Ratings and the re-dispatch does not result in any Non- Consequential Load Loss. Where limited options for re-dispatch exist, sensitivities associated with the availability of those resources should be considered.</p>	Contingency are addressed TPL-001-4 Table 1 note e and footnote 9.
<p><b>R2.5.</b> Starting with all Facilities in service and following any of the multiple Contingencies identified in Reliability Standard TPL-003 the system shall demonstrate transient, dynamic and voltage stability;</p>	<p><b>TPL-001-4 Table1:</b> <b>Notes: ‘a’, ‘f’, ‘g’ ‘j’</b></p> <p><b>TPL-001-4 Table1:</b> Categories P3 – P7 Multiple Contingency Events</p>	Multiple contingency BES planned performance is addressed as Category P3 - P7 in TPL-001-4 Table 1. These include the multiple contingency events that start with all Facilities in service (P4, P5 & P7). Notes a through j from Table 1 (above) specify the applicable performance criteria.

Standard: FAC-010-3 — System Operating Limits Methodology for the Planning Horizon		
Requirement in Approved Standard	Translation to New Standard or Other Action	Description and Change Justification
	all Facilities shall be operating within their Facility Ratings and within their thermal, voltage and stability limits; and Cascading or uncontrolled separation shall not occur.	
<b>R2.6.</b>	In determining the system’s response to any of the multiple Contingencies, identified in Reliability Standard TPL-003, in addition to the actions identified in R2.3.1 and R2.3.2, the following shall be acceptable:	<b>TPL-001-4, Requirement R2.7.3</b> <b>TPL-001-4 Table 1</b>
<b>R2.6.1.</b>	Planned or controlled interruption of electric supply to customers (load shedding), the planned removal from service of certain generators, and/or the curtailment of contracted Firm (non-recallable reserved) electric power Transfers.	Allowable actions for BES planned performance in response to multiple contingencies are addressed in TPL-001-4 Requirement R2.7.3 and Table 1, including all actions that were acceptable in response to single Contingencies discussed above; and load shedding and curtailment of Firm Transmission Service.
		Table 1 in TPL-001-4 specifies the conditions where service interruption is acceptable.
		<b>TPL-001-4, Requirement R2, Part 2.7.3.</b> <b>2.7.3.</b> If situations arise that are beyond the control of the Transmission Planner or Planning Coordinator that prevent the implementation of a Corrective Action Plan in the required timeframe, then the Transmission Planner or Planning Coordinator is permitted to utilize Non-Consequential Load Loss and curtailment of Firm Transmission Service to correct the situation that would normally not be permitted in Table 1, provided that the Transmission Planner or Planning Coordinator documents that they are taking

**Standard: FAC-010-3 — System Operating Limits Methodology for the Planning Horizon**

Requirement in Approved Standard	Translation to New Standard or Other Action	Description and Change Justification
	<p>actions to resolve the situation. The Transmission Planner or Planning Coordinator shall document the situation causing the problem, alternatives evaluated, and the use of Non-Consequential Load Loss or curtailment of Firm Transmission Service.</p> <p><b>TPL-001-4 Table 1:</b> Footnote 9 (refer to R2.4 section) Footnote 12. An objective of the planning process is to minimize the likelihood and magnitude of Non-Consequential Load Loss following planning events. In limited circumstances, Non-Consequential Load Loss may be needed throughout the planning horizon to ensure that BES performance requirements are met. However, when Non-Consequential Load Loss is utilized under footnote 12 within the Near-Term Transmission Planning Horizon to address BES performance requirements, such interruption is limited to circumstances where the Non-Consequential Load Loss meets the conditions shown in Attachment 1. In no case can the planned Non-Consequential Load Loss under footnote 12 exceed 75 MW</p>	

**Standard: FAC-010-3 — System Operating Limits Methodology for the Planning Horizon**

Requirement in Approved Standard	Translation to New Standard or Other Action	Description and Change Justification
	for US registered entities. The amount of planned Non-Consequential Load Loss for a non-US Registered Entity should be implemented in a manner that is consistent with, or under the direction of, the applicable governmental authority or its agency in the non-US jurisdiction.	
<p><b>R3.</b> The Planning Authority’s methodology for determining SOLs, shall include, as a minimum, a description of the following, along with any reliability margins applied for each:</p>		<p>The proposed construct as described in the document introduction does not make use of an SOL methodology applicable to the planning horizon. The SDT also acknowledges that the June 2013 report from the Independent Experts Review Project identified FAC-010-2.1, Requirements R3 and R4 as “Requirements Recommended for Retirement” in Appendix E of the report (R5 had since been retired).</p> <p>Requirement R3 was identified as “More appropriate as a Guideline. This is a checklist.”</p>
<p><b>R3.1.</b> Study model (must include at least the entire Planning Authority Area as well as the critical modeling details from other Planning Authority Areas that would impact the Facility or Facilities under study).</p>	<p><b>TPL-001-4, Requirement R1: R1.</b> (refer to Requirement R2.1 section above)</p>	<p>Study model used for BES planned performance is specified in approved TPL-001-4, Requirement R1.</p>

**Standard: FAC-010-3 — System Operating Limits Methodology for the Planning Horizon**

Requirement in Approved Standard	Translation to New Standard or Other Action	Description and Change Justification
<p><b>R3.2.</b> Selection of applicable Contingencies.</p>	<p><b>TPL-001-4 Table1:</b> Categories P1 – P7 Planning Events</p>	<p>Applicable contingencies for BES planned performance are specified in approved TPL-001-4 Table 1.</p>
<p><b>R3.3.</b> Level of detail of system models used to determine SOLs.</p>	<p><b>TPL-001-4, Requirement R1:</b> <b>R1.</b> (refer to Requirement R1 section above)</p>	<p>Model details for BES planned performance are specified in approved TPL-001-4, Requirement R1.</p>
<p><b>R3.4.</b> Allowed uses of Remedial Action Schemes.</p>	<p><b>TPL-001-4, Requirement R2, Part 2.7:</b> <b>2.7.</b> For planning events shown in TPL-001-4 Table 1, when the analysis indicates an inability of the System to meet the performance requirements in Table 1, the Planning Assessment shall include Corrective Action Plan(s) addressing how the performance requirements will be met. Revisions to the Corrective Action Plan(s) are allowed in subsequent Planning Assessments but the planned System shall continue to meet the performance requirements in Table 1. Corrective Action Plan(s) do not need to be developed solely to meet the performance requirements for a single sensitivity case analyzed in accordance with TPL-001-4, Requirements R2, Parts 2.1.4 and 2.4.3. The Corrective Action Plan(s) shall: <b>2.7.1.</b> List System deficiencies and the associated actions needed to</p>	<p>TPL-001-4, Requirement R2.7 requires the development of a Corrective Action Plan to address system deficiencies. The Corrective Action Plan is required to include any automatic tripping or other automated protection that is required to meet the performance criteria in TPL-001-4 Table 1.</p>



Standard: FAC-010-3 — System Operating Limits Methodology for the Planning Horizon		
Requirement in Approved Standard	Translation to New Standard or Other Action	Description and Change Justification
	<p>achieve required System performance. Examples of such actions include:</p> <ul style="list-style-type: none"> <li>• Installation, modification, or removal of Protection Systems or Special Protection Systems</li> <li>• Installation or modification of automatic generation tripping as a response to a single or multiple Contingency to mitigate Stability performance violations.</li> <li>• Installation or modification of manual and automatic generation runback/tripping as a response to a single or multiple Contingency to mitigate steady state performance violations.</li> </ul>	
<p><b>R3.5.</b> Anticipated transmission system configuration, generation dispatch and Load level.</p>	<p><b>TPL-001-4, Requirement R1:</b> <b>R1.</b> (refer to Requirement R1 section above)</p>	<p>Anticipated transmission dispatch, generation, and load levels are incorporated into study models used for BES planned performance as specified in TPL-001-4, Requirement R1.</p>

**Standard: FAC-010-3 — System Operating Limits Methodology for the Planning Horizon**

Requirement in Approved Standard	Translation to New Standard or Other Action	Description and Change Justification
<p><b>R3.6.</b> Criteria for determining when violating a SOL qualifies as an Interconnection Reliability Operating Limit (IROL) and criteria for developing any associated IROL <math>T_v</math></p>	<p>See mapping for Requirement R1, Part 1.3</p>	<p>See mapping for Requirement R1.3</p>
<p><b>R4.</b> The Planning Authority shall issue its SOL Methodology, and any change to that methodology, to all of the following prior to the effectiveness of the change:</p>		<p>The proposed construct as described in the document introduction does not make use of an SOL methodology applicable to the planning horizon. The modeling and performance requirements as well as the reliability objectives of FAC-010-3 are redundant with those in TPL-001-4. Furthermore, the Planning Assessment required by TPL-001-4 is distributed, in accordance with TPL-001-4 Requirement R8 and IRO-017 Requirement R3, to all applicable entities listed in FAC-010-3 Requirement R4.</p>
<p><b>R4.1.</b> Each adjacent Planning Authority and each Planning Authority that indicated it has a reliability-related need for the methodology.</p>	<p><b>TPL-001-4, Requirement R8:</b>  <b>R8.</b> Each Planning Coordinator and Transmission Planner shall distribute its Planning Assessment results to adjacent Planning Coordinators and adjacent Transmission Planners within 90 calendar days of completing its Planning Assessment, and to any functional entity that has a reliability related need and submits a written request for the information within 30 days of such a request.</p>	<p>The SDT also acknowledges that the June 2013 report from the Independent Experts Review Project identified FAC-010-2.1, Requirements R3 and R4 as “Requirements Recommended for Retirement” in Appendix E of the report (Requirement R5 had since been retired).</p>
<p><b>R4.2.</b> Each Reliability Coordinator and Transmission Operator that operates any portion of the Planning Authority’s Planning Authority Area.</p>	<p><b>TPL-001-4, Requirement R8:</b>  <b>R8.</b> (refer to Requirement R4, Part 4.1 section above)  <b>IRO-017-1, Requirement R3:</b></p>	<p>Requirement R4 was identified as “More appropriate as a Guideline. Description of</p>

**Standard: FAC-010-3 — System Operating Limits Methodology for the Planning Horizon**

Requirement in Approved Standard	Translation to New Standard or Other Action	Description and Change Justification
	<p><b>R3.</b> Each Planning Coordinator and Transmission Planner shall provide its Planning Assessment to impacted Reliability Coordinators.</p>	<p>appropriate coordination does not rise to a Standard.”</p>
<p><b>R4.3.</b> Each Transmission Planner that works in the Planning Authority’s Planning Authority Area.</p>	<p>See mapping for Requirement R4, Part 4.1</p>	

Exhibit D-2

Mapping Document  
FAC-011-4

## Mapping Document

### Project 2015-09 Establish and Communicate System Operating Limits

Standard FAC-011-3 - System Operating Limits Methodology for the Operations Horizon		
Requirement in Approved Standard	Translation to New Standard or Other Action	Description and Change Justification
<p>FAC-011-3, Requirement R1.</p> <p>The Reliability Coordinator shall have a documented methodology for use in developing SOLs (SOL Methodology) within its Reliability Coordinator Area. This SOL Methodology shall:</p>	<p>FAC-011-4, Requirement R1.</p> <p>Each Reliability Coordinator shall have a documented methodology for establishing SOLs (i.e., SOL methodology) within its Reliability Coordinator Area.</p>	<p>No change.</p>
<p>FAC-011-3, Requirement R1, R1.1.</p> <p>[This SOL Methodology shall] Be applicable for developing SOLs used in the operations horizon.</p>	<p>This requirement was removed.</p>	<p>The stated purpose of FAC-011-4 is “To ensure that System Operating Limits (SOLs) used in the reliable operation of the Bulk Electric System (BES) are determined based on an established methodology or methodologies.” The title of FAC-011-4 is “System Operating Limits Methodology for the Operations Horizon”. Therefore, every requirement in FAC-011-4 is intended for developing SOLs used in the operations</p>

**Standard FAC-011-3 - System Operating Limits Methodology for the Operations Horizon**

Requirement in Approved Standard	Translation to New Standard or Other Action	Description and Change Justification
		<p>horizon. Accordingly, there is no reliability-related need to have a requirement specifying that the Reliability Coordinator’s (RC’s) SOL methodology is applicable for developing SOLs used in the operations horizon.</p>
<p>FAC-011-3, Requirement R1, R1.2. [This SOL Methodology shall] State that SOLs shall not exceed associated Facility Ratings.</p>	<p>This requirement is addressed in proposed FAC-011-4 Requirement R2 in conjunction with the definitions for Operational Planning Analysis and Real-time Assessment in the NERC Glossary of Terms.</p> <p><u>FAC-011-4 Requirement R2</u>: Each Reliability Coordinator shall include in its SOL methodology the method for Transmission Operators to determine which owner-provided Facility Ratings are to be used in operations such that the Transmission Operator and its Reliability Coordinator use common Facility Ratings.</p> <p><u>Operational Planning Analysis</u> is defined in the NERC Glossary of Terms as “An evaluation of projected system conditions to assess anticipated (pre-Contingency) and potential (post-Contingency) conditions for</p>	<p>Facility Ratings to be used in operations as SOLs is addressed through FAC-011-4, Requirement R2.</p> <p>Facility Ratings that are determined per Requirement R2 are a required input for Operational Planning Analyses (OPA) and Real-time Assessments (RTA) per the definitions, and therefore address the analysis of system performance with respect to Facility Ratings. Facility Rating exceedances are determined through OPAs and RTAs.</p>

**Standard FAC-011-3 - System Operating Limits Methodology for the Operations Horizon**

Requirement in Approved Standard	Translation to New Standard or Other Action	Description and Change Justification
	<p><i>next-day operations. The evaluation shall reflect applicable inputs including, but not limited to, load forecasts; generation output levels; Interchange; known Protection System and Special Protection System status or degradation; Transmission outages; generator outages; Facility Ratings; and identified phase angle and equipment limitations. (Operational Planning Analysis may be provided through internal systems or through third-party services.)”</i></p> <p><u>Real-time Assessment</u> is defined in the NERC Glossary of Terms as “An evaluation of system conditions using Real-time data to assess existing (pre-Contingency) and potential (post-Contingency) operating conditions. The assessment shall reflect applicable inputs including, but not limited to: load, generation output levels, known Protection System and Special Protection System status or degradation, Transmission outages, generator outages, Interchange, Facility Ratings, and identified phase angle and equipment limitations. (Real-time Assessment may be provided through</p>	

**Standard FAC-011-3 - System Operating Limits Methodology for the Operations Horizon**

Requirement in Approved Standard	Translation to New Standard or Other Action	Description and Change Justification
	<i>internal systems or through third-party services.)”</i>	
<p>FAC-011-3, Requirement R1, R1.3.</p> <p>[This SOL Methodology shall] Include a description of how to identify the subset of SOLs that qualify as IROLs.</p>	<p>FAC-011-4, Requirement R8 and Part 8.1.</p> <p>R8. Each Reliability Coordinator shall include in its SOL methodology</p> <p>8.1. A description of how to identify the subset of SOLs that qualify as Interconnection Reliability Operating Limits (IROLs).</p>	<p>The language from the approved standard was maintained in the proposed FAC-011-4.</p>
<p>FAC-011-3, Requirements R2, R2.1 and R2.2.</p> <p>R2. The Reliability Coordinator’s SOL Methodology shall include a requirement that SOLs provide BES performance consistent with the following:</p> <p>R2.1 In the pre-contingency state, the BES shall demonstrate transient, dynamic and voltage stability; all Facilities shall be within their Facility Ratings and within their thermal, voltage and stability limits. In the determination of SOLs, the BES condition used shall reflect current or expected system</p>	<p>FAC-011-4 Requirement R6 and Parts 6.1, 6.2, 6.3, and 6.4.</p> <p>R6. Each Reliability Coordinator shall include the following performance framework in its SOL methodology to determine SOL exceedances when performing Real-time monitoring, Real-time Assessments, and Operational Planning Analyses:</p> <p>6.1. System performance for no Contingencies</p>	<p>The items in approved FAC-011-3, Requirement R2.1 and R2.2 are addressed through proposed FAC-011-4, Requirement R6 and its subparts as well as proposed TOP-001-6 R25 and IRO-008-3 R7.</p> <p>While FAC-011-3 R2.1 focuses on pre-contingency BES performance for all three types of SOL (Facility Ratings, System Voltage Limits and stability limits) together, FAC-011-4 Requirement R6 Parts R6.1, 6.1.1, 6.1.2, 6.1.3 and 6.1.4 divide system performance requirements for the no contingency state (N-0) into each of the</p>



**Standard FAC-011-3 - System Operating Limits Methodology for the Operations Horizon**

Requirement in Approved Standard	Translation to New Standard or Other Action	Description and Change Justification
<p>conditions and shall reflect changes to system topology such as Facility outages.</p> <p>R2.2. Following the single Contingencies identified in Requirement R2, R2.2.1 - R2.2.3, the system shall demonstrate transient, dynamic and voltage stability; all Facilities shall be operating within their Facility Ratings and within their thermal, voltage and stability limits; and Cascading or uncontrolled separation shall not occur.</p>	<p>demonstrates the following:</p> <p>6.1.1. Steady state flow through Facilities are within Normal Ratings; however, Emergency Ratings may be used when System adjustments to return the flow within its Normal Rating could be executed and completed within the specified time duration of those Emergency Ratings..</p> <p>6.1.2. Steady state voltages are within normal System Voltage Limits; however, emergency System Voltage Limits may be used when System</p>	<p>three categories (Facility Ratings, System Voltage Limits, and stability limits) into its own subpart for clarity. Cascading and uncontrolled separation were included in Part 6.1.4. The proposed language adds clarity by clearly identifying expectations relative to normal and emergency Facility Ratings and System Voltage Limits.</p> <p>Similarly, FAC-011-3 Requirement R2.2 focuses on post-contingency BES performance for all three types of SOL (Facility Ratings, System Voltage Limits and stability limits) together, while FAC-011-4 Requirement R6 Parts 6.2, 6.2.1, 6.2.2, 6.2.3 and 6.2.4 divides system performance requirements for the evaluation of Contingencies against the pre-Contingency state for the anticipated post-Contingency state (N-1) or (N-x) into each of the three categories (Facility Ratings, System Voltage Limits, and stability limits) into its own subpart for clarity. Cascading and uncontrolled separation were included in</p>

**Standard FAC-011-3 - System Operating Limits Methodology for the Operations Horizon**

Requirement in Approved Standard	Translation to New Standard or Other Action	Description and Change Justification
	<p>adjustments to return the voltage within its normal System Voltage Limits could be executed and completed within the specified time duration of those emergency System Voltage Limits.</p> <p>6.1.3. Predetermined stability limits are not exceeded.</p> <p>6.1.4. Instability, Cascading or uncontrolled separation that adversely impact the reliability of the Bulk Electric System does not occur.</p> <p>6.2. System performance for the single Contingencies listed in Part 5.1</p>	<p>Part 6.2.4. The proposed language adds clarity by clearly identifying expectations relative to normal and emergency Facility Ratings and System Voltage Limits.</p> <p>In a similar fashion, Part 6.3 identifies the minimum requirement for BES performance for those Contingencies identified in FAC-011-4 Requirement R5 Part 5.2 which is to demonstrate “that instability, Cascading, or uncontrolled separation that adversely impact the reliability of the Bulk Electric System does not occur.”</p> <p>FAC-011-4 Proposed Part 6.4 is meant to clearly identify that, in determining the System’s response to any Contingency identified in Requirement R5, planned manual load shedding is an acceptable only after all other available System adjustments have been made.</p> <p>TOP-001-5, Requirement R25 and IRO-008-3, Requirement R7 support FAC-011-4 Requirement R6 and its parts by requiring TOPs and RCs to determine SOL</p>

**Standard FAC-011-3 - System Operating Limits Methodology for the Operations Horizon**

Requirement in Approved Standard	Translation to New Standard or Other Action	Description and Change Justification
	<p>demonstrates the following:</p> <ul style="list-style-type: none"> <li>6.2.1. Steady state post-Contingency flow through Facilities within applicable Emergency Ratings. Steady state post-Contingency flow through a Facility must not be above the Facility’s highest Emergency Rating.</li> <li>6.2.2. Steady state post-Contingency voltages are within emergency System Voltage Limits.</li> <li>6.2.3. The stability performance criteria defined in the Reliability Coordinator’s SOL methodology are met.</li> </ul>	<p>exceedances in accordance with its RC’s the SOL methodology.</p>

**Standard FAC-011-3 - System Operating Limits Methodology for the Operations Horizon**

Requirement in Approved Standard	Translation to New Standard or Other Action	Description and Change Justification
	<p>6.2.4. Instability, Cascading or uncontrolled separation that adversely impact the reliability of the Bulk Electric System does not occur.</p> <p>6.3. System performance for applicable Contingencies identified in Part 5.2 demonstrates that: instability, Cascading, or uncontrolled separation that adversely impact the reliability of the Bulk Electric System does not occur.</p> <p>6.4 In determining the System’s response to any Contingency identified in Requirement R5, planned manual load shedding is acceptable only after all other available System adjustments have been made.</p>	

**Standard FAC-011-3 - System Operating Limits Methodology for the Operations Horizon**

Requirement in Approved Standard	Translation to New Standard or Other Action	Description and Change Justification
	<p>TOP-001-6, Requirement R25.</p> <p>R25. Each Transmission Operator shall use the applicable Reliability Coordinator’s SOL methodology when determining SOL exceedances for Real-time Assessments, Real-time monitoring, and Operational Planning Analysis. .</p> <p>IRO-008-3, Requirement R7.</p> <p>R7. Each Reliability Coordinator shall use its SOL methodology when determining SOL exceedances for Real-time Assessments, Real-time monitoring, and Operational Planning Analysis.</p>	
<p>FAC-011-3, Requirement R2, sub-requirements R2.2.1, R2.2.2, and R2.2.3</p> <p>R2.2.1. Single line to ground or 3-phase Fault (whichever is more severe), with Normal</p>	<p>FAC-011-4, Requirement R5, Part 5.1</p> <p>5.1 Specify the following single Contingency events</p> <p>5.1.1 Loss of any of the following either by single phase to ground or three phase Fault</p>	<p>The requirements in approved FAC-011-3 were consolidated into a single requirement in proposed FAC-011-4 Requirement R5, Part 5.1.</p>

**Standard FAC-011-3 - System Operating Limits Methodology for the Operations Horizon**

Requirement in Approved Standard	Translation to New Standard or Other Action	Description and Change Justification
<p>Clearing, on any Faulted generator, line, transformer, or shunt device.</p> <p>R2.2.2. Loss of any generator, line, transformer, or shunt device without a Fault.</p> <p>R2.2.3. Single pole block, with Normal Clearing, in a monopolar or bipolar high voltage direct current system.</p>	<p>(whichever is more severe) with Normal Clearing, or without a Fault:</p> <ul style="list-style-type: none"> <li>• generator;</li> <li>• transmission circuit;</li> <li>• transformer;</li> <li>• shunt device; or</li> <li>• single pole block, with, in a monopolar or bipolar high voltage direct current system.</li> </ul>	<p>FAC-011-4 Requirement R5, Part 5.1. is also referenced in FAC-011-4 Requirement R6, Part 6.2 for the system performance requirements for anticipated post-contingency state.</p>
<p>FAC-011-3, Requirement R2.3, sub-requirements R2.3.1, R2.3.2, R2.3.3, and Requirement R2.4.</p> <p>R2.3 In determining the system’s response to a single Contingency, the following shall be acceptable:</p> <p>R2.3.1. Planned or controlled interruption of electric supply to radial customers or some local network customers connected to or supplied by the Faulted Facility or by the affected area.</p> <p>R2.3.2. Interruption of other network customers, (a) only if the system has already been adjusted, or is being adjusted, following</p>	<p>The issues that pertain to the establishment of SOLs are addressed through FAC-011-4 Requirement R4 :</p> <p><u>FAC-011-4 Requirement R4:</u> Each Reliability Coordinator shall include in its SOL methodology the method for determining the stability limits to be used in operations. The method shall:</p> <p>4.1. Specify stability performance criteria, including any margins applied. The criteria shall, at a minimum, include the following:</p> <p>4.1.1. steady-state voltage stability;</p>	<p>The reliability issues denoted in FAC-011-3 Requirement R2.3, sub-requirements R2.3.1, R2.3.2, R2.3.3, and R2.4 represent a combination of issues that are relevant to the establishment of SOLs and those that are relevant to “how the system is to be operated.”</p> <p>Requirement R2, R2.3 describes an acceptable System response to single Contingencies. These requirements are sub-requirements of Requirement R2, which addresses the establishment of SOLs that “provide a certain level of BES performance”. “BES performance” as stated</p>

**Standard FAC-011-3 - System Operating Limits Methodology for the Operations Horizon**

Requirement in Approved Standard	Translation to New Standard or Other Action	Description and Change Justification
<p>at least one prior outage, or (b) if the real-time operating conditions are more adverse than anticipated in the corresponding studies</p> <p>R2.3.3. System reconfiguration through manual or automatic control or protection actions.</p> <p>R2.4 To prepare for the next Contingency, system adjustments may be made, including changes to generation, uses of the transmission system, and the transmission system topology.</p>	<p>4.1.2. transient voltage response;</p> <p>4.1.3. angular stability; and</p> <p>4.1.4. System damping.</p> <p>4.2. Require that stability limits are established to meet the criteria specified in Part 4.1 for the Contingencies identified in Requirement R5 applicable to the establishment of stability limits that are expected to produce more severe System impacts on its portion of the BES.</p> <p>4.3. Describe how the Reliability Coordinator establishes stability limits when there is an impact to more than one Transmission Operator in its Reliability Coordinator Area or other Reliability Coordinator Areas.</p> <p>4.4. Describe how stability limits are determined, considering levels of transfers, Load and generation dispatch, and System conditions including any changes to System topology such as Facility outages.</p> <p>4.5. Describe the level of detail that is required for the study model(s), including</p>	<p>in FAC-011-3, Requirement R2 is not determined through SOLs in and of themselves. SOLs are an input into OPAs and RTAs. The OPA and RTA evaluation against those SOLs provide for reliable system performance by ensuring through these analyses/assessments that the system performs reliably in the pre- and post-Contingency states (i.e., that the system is within thermal (Facility Ratings), System Voltage Limits, and stability limits pre- and post-Contingency). Per the TOP and IRO standards, RTAs must be performed at least once every 30 minutes. Accordingly, each new operating state is “studied” at least once every 30 minutes. Additionally, per the TOP standards, SOL exceedance triggers the development and implementation of an Operating Plan to address that SOL exceedance.</p> <p>Insofar as the issues in FAC-011-3, Requirement R2, R2.3 and R2.4 correlate to the establishment of SOLs, automatic control actions relevant to the establishment of stability limits are</p>

**Standard FAC-011-3 - System Operating Limits Methodology for the Operations Horizon**

Requirement in Approved Standard	Translation to New Standard or Other Action	Description and Change Justification
	<p>the portion modeled of the Reliability Coordinator Area, and the critical modeling details from other Reliability Coordinator Areas, necessary to determine different types of stability limits.</p> <p>4.6. Describe the allowed uses of Remedial Action Schemes and other automatic post-Contingency mitigation actions in establishing stability limits used in operations.</p> <p>4.7 State that the use of underfrequency load shedding (UFLS) and Undervoltage Load Shedding Programs are not allowed in the establishment of stability limits.</p> <p>The issues that are more centric to “how the system is to be operated” are more appropriately addressed in the development and implementation of Operating Plans as denoted in the following standards:</p> <ol style="list-style-type: none"> <li>1. <u>TOP-002-4, Requirement R2</u>: Each Transmission Operator shall have an Operating Plan(s) for next-day operations to address potential</li> </ol>	<p>addressed in FAC-011-4 Requirement R4, Part 4.6 which requires the SOL methodology to describe the allowed uses of Remedial Action Schemes (RAS) and other automatic post-Contingency mitigation actions as part of stability limit establishment. Accordingly, any RAS or automatic mitigation scheme (which includes those that interrupt customers or reconfigure the system) are required to be reflected in the establishment of stability limits per Requirement R4, Part 4.6. Furthermore, per Requirement R4, Part 4.4, stability limits are required to take into consideration the configuration of the system, which may include any necessary manual actions taken by the System Operator to configure the system in a manner that supports the use of a given stability limit.</p> <p>However, insofar as FAC-011-3, Requirement R2, R2.3 and R2.4 correlate to “how the system is to be operated”, the operational decisions related to customer interruption and system reconfiguration are</p>



**Standard FAC-011-3 - System Operating Limits Methodology for the Operations Horizon**

Requirement in Approved Standard	Translation to New Standard or Other Action	Description and Change Justification
	<p>System Operating Limit (SOL) exceedances identified as a result of its Operational Planning Analysis as required in Requirement R1.</p> <ol style="list-style-type: none"> <li>2. <u>TOP-002-4, Requirement R3</u>: Each Transmission Operator shall notify entities identified in the Operating Plan(s) cited in Requirement R2 as to their role in those plan(s).</li> <li>3. <u>TOP-002-4, Requirement R6</u>: Each Transmission Operator shall provide its Operating Plan(s) for next-day operations identified in Requirement R2 to its Reliability Coordinator.</li> <li>4. <u>TOP-002-4, Requirement R14</u>: Each Transmission Operator shall initiate its Operating Plan to mitigate a SOL exceedance identified as part of its Real-time monitoring or Real-time Assessment.</li> <li>5. <u>IRO-008-3, Requirement R2</u>: Each Reliability Coordinator shall have a coordinated Operating Plan(s) for next-day operations to address potential System Operating Limit</li> </ol>	<p>governed by the Operating Plan, if such actions are necessary to address SOL exceedance. The SDT has proposed retaining the concept captured in FAC-011-3 Requirement R2.3.2 in proposed FAC-011-4 Requirement R6.4 albeit with improved language for clarity. Rather than specifying the operating conditions where interruption of network customers is allowed, the SDT has clarified when planned manual load shedding is acceptable. This recognizes that RTAs must be conducted every 30 minutes (i.e. system is constantly being evaluated and readjusted at least every 30 minutes) as well as incorporating the principle that load shed will be a measure of last resort as supported by FERC Orders (e.g. FERC Order 693 para 591.) While a System Operator maintains authority to take whatever action is needed to ensure reliability, entities should not “plan” to shed load until all other system adjustments (e.g. generation commitment, generation redispatch, transmission system adjustments, interruptible loads, etc.) have been made.</p>

**Standard FAC-011-3 - System Operating Limits Methodology for the Operations Horizon**

Requirement in Approved Standard	Translation to New Standard or Other Action	Description and Change Justification
	<p>(SOL) and Interconnection Reliability Operating Limit (IROL) exceedances identified as a result of its Operational Planning Analysis as performed in Requirement R1 while considering the Operating Plans for the next-day provided by its Transmission Operators and Balancing Authorities.</p> <p>6. <u>IRO-008-3, Requirement R3</u>: Each Reliability Coordinator shall notify impacted entities identified in its Operating Plan(s) cited in Requirement R2 as to their role in such plan(s).</p> <p>7. <u>IRO-008-3, Requirement R5</u>: Each Reliability Coordinator shall notify, in accordance with its SOL methodology impacted Transmission Operators and Balancing Authorities within its Reliability Coordinator Area, and other impacted Reliability Coordinators as indicated in its Operating Plan, when the System Operating Limit (SOL) or</p>	<p>Regarding FAC-011-3 Requirement R2.4, the need for making system adjustments to prepare for the next Contingency is standard operational practice and does not need to be specified or required by the Reliability standards. Any such actions related to the interruption of customers, reconfiguration of the system, or operational preparations for the next Contingency are expected to be included in an Operating Plan, if such actions are required by System Operators to address SOL exceedances.</p> <p>In the current body of TOP and IRO reliability standards, the Operating Plan is the mechanism for addressing SOL exceedances. The mitigation actions that System Operators take to prevent or address SOL exceedances are expected to be contained within the Operating Plan. TOPs need to have the flexibility in their Operating Plan to address the wide-ranging operational issues they may encounter. There is no reliability need for reliability standards to provide such highly</p>

**Standard FAC-011-3 - System Operating Limits Methodology for the Operations Horizon**

Requirement in Approved Standard	Translation to New Standard or Other Action	Description and Change Justification
	<p>Interconnection Reliability Operating Limit (IROL) exceedance identified in Requirement R5 has been prevented or mitigated.</p> <p>The SDT has proposed retaining the concept captured in FAC-011-3 R2.3.2 in proposed FAC-011-4 R6.4 albeit with improved language for clarity.</p> <p>FAC-011-4 Each Reliability Coordinator shall include the following performance framework in its SOL methodology to determine SOL exceedances when performing Real-time monitoring, Real-time Assessments, and Operational Planning Analyses:</p> <p>R6.4 In determining the System’s response to any Contingency identified in Requirement R5, planned manual load shedding is acceptable only after all other available System adjustments have been made.</p>	<p>prescriptive requirements which specify how TOPs are to operate the system.</p> <p>Because the development and implementation of Operating Plans is addressed in the current body of reliability standards and proposed FAC-011-4 Requirement 6.4, reliability is not compromised by the removal of FAC-011-3, Requirement R2, R2.3 and R2.4.</p>

**Standard FAC-011-3 - System Operating Limits Methodology for the Operations Horizon**

Requirement in Approved Standard	Translation to New Standard or Other Action	Description and Change Justification
<p>FAC-011-3, Requirement R3, R3.1</p> <p>R3. The Reliability Coordinator’s methodology for determining SOLs, shall include, as a minimum, a description of the following, along with any reliability margins applied for each:</p> <p>R3.1 Study model (must include at least the entire Reliability Coordinator Area as well as the critical modeling details from other Reliability Coordinator Areas that would impact the Facility or Facilities under study.)</p>	<p>FAC-011-4, Requirement R4, Part 4.5</p> <p>R4. Each Reliability Coordinator shall include in its SOL methodology the method for determining the stability limits to be used in operations. The method shall:</p> <p>4.5. Describe the level of detail that is required for the study model(s), including the portion modeled of the Reliability Coordinator Area, and the critical modeling details from other Reliability Coordinator Areas, necessary to determine different types of stability limits.</p>	<p>FAC-011-3, Requirement R3, R3.1 and R3.4 both address the study model. These two requirements are addressed with the single requirement in proposed FAC-011-4, Requirement R4, Part 4.5.</p> <p>Facility Ratings are created and provided through FAC-008 and further examined through FAC-011-4, Requirement R2. System Voltage Limits are created per FAC-011-4, Requirement R3. Neither of these types of SOLs are necessarily a byproduct of a “study” or study model. As a result, no study model reference is needed in FAC-011-4 for Facility Ratings or System Voltage Limits.</p> <p>However, for those RCs or TOPs that determine stability limits, a study model is needed to perform the “study”. Therefore, the level of detail of the study model falls under the requirement associated with establishing stability limits (R4).</p> <p>FAC-011-4, Requirement R4, Part 4.5 affords the RC with the flexibility to the extent of the modeling area (including other RC</p>

**Standard FAC-011-3 - System Operating Limits Methodology for the Operations Horizon**

Requirement in Approved Standard	Translation to New Standard or Other Action	Description and Change Justification
		<p>areas) that must be modeled to reflect the varying needs for different types of stability limits (e.g. local single unit stability up to wide-area or inter-area instability). Part 4.5 acknowledges that some types of localized stability issues do not require a model of the entire RC area to establish certain types of stability limits.</p>
<p>FAC-011-3, Requirement R3, R3.2 R3.2 [The RC’s SOL Methodology shall include] Selection of applicable Contingencies</p>	<p>FAC-011-4, Requirement R5 R5. Each Reliability Coordinator shall identify in its SOL methodology the set of Contingency events for use in determining stability limits and the set of Contingency events for use in performing Operational Planning Analysis (OPAs) and Real-time Assessments (RTAs). The SOL methodology for each set shall:  5.1. Specify the following single Contingency events:  5.1.1. Loss of any of the following, either by single phase to ground or three phase Fault (whichever is more severe) with Normal Clearing, or without a Fault:</p>	<p>All requirements regarding Contingencies are consolidated and addressed in proposed FAC-011-4, Requirement R5.</p>

**Standard FAC-011-3 - System Operating Limits Methodology for the Operations Horizon**

Requirement in Approved Standard	Translation to New Standard or Other Action	Description and Change Justification
	<ul style="list-style-type: none"> <li>• generator;</li> <li>• transmission circuit;</li> <li>• transformer;</li> <li>• shunt device;</li> <li>• single pole block in a monopolar or bipolar high voltage direct current system.</li> </ul> <p>5.2. Specify additional single or multiple Contingency events or types of Contingency events, if any.</p> <p>5.3. Describe the method(s) for identifying which, if any, of the Contingency events provided by the Planning Coordinator in accordance with FAC-014-3, Requirement R7, to use in determining stability limits.</p>	
<p>FAC-011-3, Requirement R3, R3.3 and R3.3.1.</p> <p>R3.3 [The RC’s SOL Methodology shall include] A process for determining which of the stability limits associated with the list of multiple contingencies (provided by the Planning Authority in accordance with FAC-</p>	<p>FAC-011-4, Requirement R5, Part 5.3</p> <p>R5. Each Reliability Coordinator shall identify in its SOL methodology the set of Contingency events for use in determining stability limits and the set of Contingency events for use in performing Operational</p>	<p>FAC-011-4, Requirement R5, Part 5.3 and FAC-014-3 Requirement R7 address the reliability objective in FAC-011-3, Requirement R3, R3.3.1.</p> <p>In FAC-014-3, Requirement R7, the Planning Coordinator is required to identify and</p>

**Standard FAC-011-3 - System Operating Limits Methodology for the Operations Horizon**

Requirement in Approved Standard	Translation to New Standard or Other Action	Description and Change Justification
<p>014, Requirement 6) are applicable for use in the operating horizon given the actual or expected system conditions.</p> <p>R3.3.1. This process shall address the need to modify these limits, to modify the list of limits, and to modify the list of associated multiple contingencies.</p>	<p>Planning Analysis (OPAs) and Real-time Assessments (RTAs). The SOL methodology for each set shall:</p> <p>5.3. Describe the method(s) for identifying which, if any, of the Contingency events provided by the Planning Coordinator in accordance with FAC-014-3, Requirement R7, to use in determining stability limits.</p> <p>FAC-014-3 Requirement R7:</p> <p>R7. Each Planning Coordinator and each Transmission Planner shall annually communicate the following information for Corrective Action Plans developed to address any instability identified in its Planning Assessment of the Near-Term Transmission Planning Horizon to each impacted Transmission Operator and</p>	<p>annually communicate information for Corrective Action Plans developed to address any instability identified in its Planning Assessment of the Near-Term Transmission Planning Horizon, to the RC and associated TOPs. Once the RC receives this information, the RC then applies the method required by FAC-011-4, Requirement R5, Part 5.3 for considering those Contingencies for use in determining stability limits.</p> <p>These requirements collectively address the reliability objectives of FAC-011-3, Requirement R3, R3.1.</p>

**Standard FAC-011-3 - System Operating Limits Methodology for the Operations Horizon**

Requirement in Approved Standard	Translation to New Standard or Other Action	Description and Change Justification
	<p>Reliability Coordinator. This communication shall include:</p> <ul style="list-style-type: none"> <li><b>7.1</b> The Corrective Action Plan developed to mitigate the identified instability, including any automatic control or operator-assisted actions (such as Remedial Action Schemes, under voltage load shedding, or any Operating Procedures);</li> <li><b>7.2</b> The type of instability addressed by the Corrective Action Plan (e.g. steady-state and/or transient voltage instability, angular instability including generating unit loss of synchronism and/or unacceptable damping);</li> <li><b>7.3</b> The associated stability criteria violation requiring the Corrective Action Plan (e.g. violation of transient</li> </ul>	



**Standard FAC-011-3 - System Operating Limits Methodology for the Operations Horizon**

Requirement in Approved Standard	Translation to New Standard or Other Action	Description and Change Justification
	<p>voltage response criteria or damping rate criteria);</p> <p><b>7.4</b> The planning event Contingency(ies) associated with the identified instability requiring the Corrective Action Plan;</p> <p><b>7.5</b> The System conditions and Facilities associated with the identified instability requiring the Corrective Action Plan</p>	
<p>FAC-011-3, Requirement 3, R3.4.</p> <p>R3.4 [The RC’s SOL Methodology shall include] Level of detail of system models used to determine SOLs.</p>	<p>FAC-011-4, Requirement R4, Part 4.5</p> <p>R4. Each Reliability Coordinator shall include in its SOL methodology the method for determining the stability limits to be used in operations. The method shall:</p> <p>4.5. Describe the level of detail that is required for the study model(s), including the portion modeled of the Reliability Coordinator Area, and the critical modeling details from other Reliability Coordinator</p>	<p>Reference the explanation provided for FAC-011-3, Requirement R3, R3.1.</p>

**Standard FAC-011-3 - System Operating Limits Methodology for the Operations Horizon**

Requirement in Approved Standard	Translation to New Standard or Other Action	Description and Change Justification
	Areas, necessary to determine different types of stability limits.	
<p>FAC-011-3, Requirement R3, R3.5. R3.5 [The RC’s SOL Methodology shall include] Allowed uses of Remedial Action Schemes.</p>	<p>FAC-011-4, Requirement R4, Part 4.6 and Part 4.7</p> <p>R4. Each Reliability Coordinator shall include in its SOL methodology the method for determining the stability limits to be used in operations. The method shall:</p> <p>4.6 Describe the allowed uses of Remedial Action Schemes and other automatic post-Contingency mitigation actions in establishing stability limits used in operations.</p> <p>4.7 State that the use of underfrequency load shedding (UFLS) programs and Undervoltage Load Shedding (UVLS) Programs are not allowed in the establishment of stability limits.</p>	<p>FAC-011-3, Requirement R3, R3.5 was carried over into FAC-011-4, Requirement R4, Part 4.6. The requirement has been clarified by adding Part 4.7 which restricts the use of UFLS programs and UVLS Programs in the establishment of stability limits.</p>
<p>FAC-011-3, Requirement R3, R3.6. R3.6 [The RC’s SOL Methodology shall include] Anticipated transmission system</p>	<p>FAC-011-4, Requirement R4, Part 4.4:</p> <p>R4. Each Reliability Coordinator shall include in its SOL methodology the method</p>	<p>The requirements in FAC-011-3, Requirement R3, R3.6 are addressed in</p>

**Standard FAC-011-3 - System Operating Limits Methodology for the Operations Horizon**

Requirement in Approved Standard	Translation to New Standard or Other Action	Description and Change Justification
<p>configuration, generation dispatch and Load level</p>	<p>for determining the stability limits to be used in operations. The method shall:</p> <p>4.4. Describe how stability limits are determined, considering levels of transfers, Load and generation dispatch, and System conditions including any changes to System topology such as Facility outages.</p> <p><u>TOP-002-4, Requirement R1</u>: Each Transmission Operator shall have an Operational Planning Analysis that will allow it to assess whether its planned operations for the next day within its Transmission Operator Area will exceed any of its System Operating Limits (SOLs).</p> <p><u>IRO-008-2, Requirement R1</u>: Each Reliability Coordinator shall perform an Operational Planning Analysis that will allow it to assess whether the planned operations for the next-day will exceed System Operating Limits (SOLs) and Interconnection Operating Reliability Limits (IROLs) within its Wide Area.</p> <p><u>Operational Planning Analysis</u> is defined in the NERC Glossary of Terms as “An</p>	<p>proposed FAC-011-4, Requirement R4, Part 4.4.</p> <p>Part 4.4 was included as a Part to Requirement R4 because the information is relevant to the establishment of stability limits. Facility Ratings are created and provided through FAC-008 and further examined through FAC-011-4, Requirement R2, and System Voltage Limits are created through FAC-011-4, Requirement R3. Neither of these types of SOLs are necessarily a byproduct of a “study” or study model that requires inclusion of the items in FAC-011-3, Requirement R3, R3.6.</p> <p>Additionally, TOP-002-4, Requirement R1 and IRO-008-2, Requirement R1 require the TOP and the RC respectively to have/perform an OPA.</p> <p>Per the definition of OPA, the OPA shall reflect applicable inputs which include the items required by FAC-011-3, Requirement R3, R3.6.</p> <p>Accordingly, when stability limits include the information required in Requirement</p>

Standard FAC-011-3 - System Operating Limits Methodology for the Operations Horizon		
Requirement in Approved Standard	Translation to New Standard or Other Action	Description and Change Justification
	<i>evaluation of projected system conditions to assess anticipated (pre-Contingency) and potential (post-Contingency) conditions for next-day operations. The evaluation shall reflect applicable inputs including, but not limited to, load forecasts; generation output levels; Interchange; known Protection System and Special Protection System status or degradation; Transmission outages; generator outages; Facility Ratings; and identified phase angle and equipment limitations. (Operational Planning Analysis may be provided through internal systems or through third-party services.)”</i>	R4, and the TOPs and RCs perform their required OPAs, the information in FAC-011-3, Requirement R3, R3.6 is inherently addressed.
FAC-011-3, Requirement R3, R3.7. R3.7 [The RC’s SOL Methodology shall include] Criteria for determining when violating a SOL qualifies as an Interconnection Reliability Operating Limit (IROL) and criteria for developing any associated IROL T <sub>v</sub> .	FAC-011-4, Requirement R8, Part 8.2 R8.2 Criteria for determining when exceeding a SOL qualifies as exceeding an IROL and criteria for developing any associated IROL T <sub>v</sub> .	The reliability objective of FAC-011-3, Requirement R3, R3.7 was carried over into FAC-011-4, Requirement R8, Part 8.2.
FAC-011-3, Requirement R4 and Requirement R4.1:	FAC-011-4, Requirement R9, Parts 9.1, 9.2.1 and 9.2.4:	The reliability objective of FAC-011-3, Requirement R4 was carried over to FAC-

**Standard FAC-011-3 - System Operating Limits Methodology for the Operations Horizon**

Requirement in Approved Standard	Translation to New Standard or Other Action	Description and Change Justification
<p>R4. The Reliability Coordinator shall issue its SOL Methodology and any changes to that methodology, prior to the effectiveness of the Methodology or of a change to the Methodology, to all of the following:</p> <p>R4.1. Each adjacent Reliability Coordinator and each Reliability Coordinator that indicated it has a reliability-related need for the methodology.</p>	<p>R9. Each Reliability Coordinator shall provide its SOL methodology to:</p> <p>9.1. Each Reliability Coordinator that requests and indicates it has a reliability-related need within 30 days of a request.</p> <p>9.2. Each of the following entities prior to the effective date of the SOL methodology:</p> <p>9.2.1. Each adjacent Reliability Coordinator within the same; Interconnection;</p> <p>9.2.4. Each Reliability Coordinator that has requested to receive updates and indicated it had a reliability-related need.</p>	<p>011-4, Requirement R9, Parts 9.1, 9.2.1 and 9.2.4.</p> <p>FAC-011-4 Requirement 9 was re-organized to address timely provisions of the RC’s methodology to requesting RCs in Part 9.1 and to those entities that are directly impacted and therefore must be informed for any change, in Part 9.2.</p> <p>Non-adjacent RCs, which are addressed in Parts 9.1 and 9.2.4., do not require communication of the SOL methodology prior to its effective date because these RCs are less likely to be directly impacted; however, provisions are made with Parts 9.1 and 9.2.4 for non-adjacent RCs to obtain the SOL methodology within 30 days of the request if they indicate a reliability-related need for it. 8</p>
<p>FAC-011-3, Requirement R4, R4.2</p> <p>R4.2 [communicate the SOL Methodology to] Each Planning Authority and Transmission Planner that models any portion of the</p>	<p>FAC-011-4, Requirement R9, Part 9.2 and subpart 9.2.2.</p> <p>R9. Each Reliability Coordinator shall provide its SOL methodology to:</p>	<p>The language was changed to better reflect the intent of the requirement. The requirement is intended to addresses PCs and TPs that are responsible for planning</p>

**Standard FAC-011-3 - System Operating Limits Methodology for the Operations Horizon**

Requirement in Approved Standard	Translation to New Standard or Other Action	Description and Change Justification
Reliability Coordinator’s Reliability Coordinator Area.	<p>9.2. Each of the following entities prior to the effective date of the SOL methodology:</p> <p>9.2.2. Each Planning Coordinator and Transmission Planner that is responsible for planning any portion of the Reliability Coordinator Area;</p>	within the RC Area rather than just because it has a model for an RC Area.
<p>FAC-011-3, Requirement R4, R4.3</p> <p>R4.3 [communicate the SOL Methodology to] Each Transmission Operator that operates in the Reliability Coordinator Area.</p>	<p>FAC-011-4, Requirement R9, Part 9.2 and subpart 9.2.3.</p> <p>R9. Each Reliability Coordinator shall provide its new or revised SOL methodology to:</p> <p>9.2. Each of the following entities prior to the effective date of the SOL methodology:</p> <p>9.2.3 Each Transmission Operator within its Reliability Coordinator Area; and</p>	The reliability objective of FAC-011-3, Requirement R4, R4.3 was carried over to FAC-011-4, Requirement R9, Part 9.2. and Subpart 9.2.3.

Exhibit D-3

Mapping Document  
FAC-014-3

## Mapping Document for FAC-014-3

### Project 2015-09 Establish and Communicate System Operating Limits

#### Standard: FAC-014-2 Establish and Communicate System Operating Limits

Requirement in Approved Standard	Translation to New Standard or Other Action	Description and Change Justification
<p><u>FAC-014-2, Requirement R1</u></p> <p>R1. The Reliability Coordinator shall ensure that SOLs, including Interconnection Reliability Operating Limits (IROLs), for its Reliability Coordinator Area are established and that the SOLs (including Interconnection Reliability Operating Limits) are consistent with its SOL methodology.</p>	<p><u>Requirements R1, R2, and R4 of FAC-014-3</u></p> <p>R1. Each Reliability Coordinator shall establish Interconnection Reliability Operating Limits (IROLs) for its Reliability Coordinator Area in accordance with its System Operating Limit methodology (SOL methodology).</p> <p>R2. Each Transmission Operator shall establish System Operating Limits (SOLs) for its portion of the Reliability Coordinator Area in accordance with its Reliability Coordinator’s SOL methodology.</p> <p>R4. Each Reliability Coordinator shall establish stability limits when an identified instability impacts adjacent Reliability Coordinator Areas or more than one Transmission Operator in its Reliability Coordinator Area in accordance with its SOL methodology.</p>	<p>Requirements R1, R2, and R4 of FAC-014-3 ensure that SOLs are established in accordance with the Reliability Coordinator’s (RC’s) SOL methodology.</p> <p>Requirement R1 was changed to address an issue with the existing language in FAC-014-2, Requirement R1. With the original language, the RC is responsible for ensuring that SOLs established by the Transmission Operator (TOP) per FAC-014-2, Requirement R2 are consistent with the RC’s SOL methodology. This creates a situation where the RC is responsible for “ensuring” the actions of the TOP.</p> <p>Accordingly, if the TOP does not establish SOLs per its RC’s SOL methodology, then 1) the TOP is in violation of Requirement R2, and 2) the RC by default is in violation of Requirement R1 because the RC did</p>



**Standard: FAC-014-2 Establish and Communicate System Operating Limits**

Requirement in Approved Standard	Translation to New Standard or Other Action	Description and Change Justification
		<p>not ensure that the TOP’s SOL was consistent with its SOL methodology.</p> <p>The proposed revision addresses this issue and clarifies the appropriate responsibilities of the respective functional entities.</p> <p>Additionally, this requirement carries forward the obligation of the RC to establish IROLs for its RC Area. The RC maintains primary responsibility for establishment of IROLs because these limits have the potential to impact a Wide-area.</p> <p>FAC-011-4 requirement R4 further addresses the RC responsibilities (beyond IROL establishment) for stability limit establishment where more than one TOP is impacted.</p>
<p><u>FAC-014-2, Requirement R2</u></p> <p>R2. The Transmission Operator shall establish SOLs (as directed by its Reliability Coordinator) for its portion of the Reliability</p>	<p><u>FAC-014-3, Requirement R2</u></p> <p>R2. Each Transmission Operator shall establish System Operating Limits (SOLs) for its portion of the Reliability Coordinator Area in accordance with its Reliability Coordinator’s SOL methodology.</p>	<p>The language from the existing FAC-014-2, Requirement R2 that states the TOP, “(as directed by its Reliability Coordinator)” was removed because it causes confusion and may be incorrectly understood to mean that the TOPs are</p>

**Standard: FAC-014-2 Establish and Communicate System Operating Limits**

Requirement in Approved Standard	Translation to New Standard or Other Action	Description and Change Justification
<p>Coordinator Area that are consistent with its Reliability Coordinator’s SOL methodology.</p>		<p>only required to establish SOLs if they have been “directed to by their RC.” This is not the intended meaning of the requirement, thus, the drafting team has removed the unnecessary and potentially confusing language. The proposed language makes clear that the TOP is the entity responsible for establishing SOLs, and that these SOLs must be established in accordance with the RC’s SOL methodology.</p>
<p><u>FAC-014-2, Requirements R3 and R4</u></p> <p>R3. The Planning Authority shall establish SOLs, including IROs, for its Planning Authority Area that are consistent with its SOL methodology.</p> <p>R4. The Transmission Planner shall establish SOLs, including IROs, for its Transmission Planning Area that are consistent with its Planning Authority’s SOL methodology.</p>	<p>FAC-011-4, Requirement R9, Part 9.2, Subpart 9.2.2</p> <p>FAC-014-3, Requirement R6</p> <p><u>FAC-011-4, Requirement R9, Part 9.2:</u></p> <p><b>R9.</b> Each Reliability Coordinator shall provide its SOL methodology to:</p> <p><b>9.2</b> Each of the following entities prior to the effective date of the SOL methodology:</p> <p><b>9.2.2</b> Each Planning Coordinator and Transmission Planner that is responsible for</p>	<p>The SDT is proposing a construct that does not make use of an SOL methodology applicable to the planning horizon or the establishment of SOLs consistent with the PC’s SOL methodology.</p> <p>The PCs and TPs responsible for planning any portion of the RC’s Area are made aware of the RC’s SOL methodology through FAC-011-4, Requirement R9, Part 9.2.2. By having the RC’s SOL methodology, PCs and TPs who plan any portion of the System in the RC Area have knowledge of the methods and criteria</p>

**Standard: FAC-014-2 Establish and Communicate System Operating Limits**

Requirement in Approved Standard	Translation to New Standard or Other Action	Description and Change Justification
	<p style="text-align: right;">planning any portion of the Reliability Coordinator Area;</p> <p><u>FAC-014-3 Requirement R6:</u></p> <p><b>R6.</b> Each Planning Coordinator and each Transmission Planner shall implement a documented process to use Facility Ratings, System steady-state voltage limits and stability criteria in its Planning Assessment of the Near-Term Transmission Planning Horizon that are equally limiting or more limiting than the criteria for Facility Ratings, System Voltage Limits and stability criteria specified described in its respective Reliability Coordinator’s SOL methodology.</p> <ul style="list-style-type: none"> <li>• The Planning Coordinator may use less limiting Facility Ratings, System steady-state voltage limits and stability criteria if it provides a technical rationale Each Planning Coordinator shall provide a technical rationale for any exceptions to each affected Transmission Planner, Transmission Operator and Reliability Coordinator.</li> <li>• The Transmission Planner may use less limiting Facility Ratings, System steady-state voltage limits and stability criteria if it provides a</li> </ul>	<p>for establishing SOLs, including the stability performance criteria used for establishing stability limits in the operations horizon.</p> <p>Proposed FAC-011-4 and FAC-014-3 represent an improvement for planning and operations to better work together to address the reliability issues that are ultimately faced in Real-time operations. FAC-014-3, Requirement R6 ensures that Planning Assessments performed for the Near-Term Transmission Planning Horizon (required by TPL-001-4), are bounded by modeling data and performance criteria that are equally limiting or more limiting than those described within the RC’s SOL methodology. FAC-014-3, Requirement R6 addresses the three components of SOLs used in operations and thus facilitates continuity between operations and planning, which is conducive to improved reliability.</p>

**Standard: FAC-014-2 Establish and Communicate System Operating Limits**

Requirement in Approved Standard	Translation to New Standard or Other Action	Description and Change Justification
	<p>technical rationale Each Transmission Planner shall provide a technical rationale for any exceptions to each affected Planning Coordinator, Transmission Operator and Reliability Coordinator.</p>	
<p><u>FAC-014-2, Requirement R5, R5.1</u></p> <p>R5. The Reliability Coordinator, Planning Authority and Transmission Planner shall each provide its SOLs and IROLs to those entities that have a reliability-related need for those limits and provide a written request that includes a schedule for delivery of those limits as follows:</p> <p>R5.1. The Reliability Coordinator shall provide its SOLs (including the subset of SOLs that are IROLs) to adjacent Reliability Coordinators and Reliability Coordinators who indicate a reliability-related need for those limits, and to the Transmission Operators, Transmission Planners, Transmission Service Providers and Planning Authorities within its Reliability Coordinator Area. For each IROL, the Reliability Coordinator shall provide the following supporting information:</p>	<p>The communication of SOL and IROL information from the Reliability Coordinator is addressed by:</p> <ol style="list-style-type: none"> <li>1. FAC-014-3, Requirement R5 (addresses communication from the Reliability Coordinator to other entities)</li> <li>2. IRO-014-3, Requirement R1 (addresses communication between Reliability Coordinators to support reliable operations)</li> </ol> <p><u>FAC-014-3, Requirement R5:</u></p> <p>R5. Each Reliability Coordinator shall provide:</p> <ol style="list-style-type: none"> <li>5.1. Each Planning Coordinator and each Transmission Planner within its Reliability Coordinator Area, SOLs for its Reliability Coordinator Area (including the subset of SOLs that are IROLs) at least once every twelve calendar months.</li> <li>5.2. Each impacted Planning Coordinator and each impacted Transmission Planner within its</li> </ol>	<p>While the existing requirements in FAC-014-2, Requirement R5 are preserved in FAC-014-3, Requirement R5, FAC-014-3, Requirement R5 more specifically address the communications requirements for the RC. Each recipient of the RC communications is addressed in a separate subpart because each recipient has a slightly different need. This approach represents an improvement over the former approach.</p> <p>IRO-014-3, Requirement R1 and subparts addresses RC communication of critical operational information to adjacent RCs, which addresses RC-to-RC communication and coordinated operations issues.</p>

**Standard: FAC-014-2 Establish and Communicate System Operating Limits**

Requirement in Approved Standard	Translation to New Standard or Other Action	Description and Change Justification
<p>R5.1.1. Identification and status of the associated Facility (or group of Facilities) that is (are) critical to the derivation of the IROL.</p> <p>R5.1.2. The value of the IROL and its associated Tv.</p> <p>R5.1.3. The associated Contingency(ies).</p> <p>R5.1.4. The type of limitation represented by the IROL (e.g., voltage collapse, angular stability).</p>	<p>Reliability Coordinator Area, the following information for each established stability limit and each established IROL at least once every twelve calendar months:</p> <p>5.2.1. The value of the stability limit or IROL;</p> <p>5.2.2. Identification of the Facilities that are critical to the derivation of the stability limit or the IROL;</p> <p>5.2.3. The associated IROL Tv for any IROL;</p> <p>5.2.4. The associated critical Contingency(ies);</p> <p>5.2.5. A description of system conditions associated with the stability limit or IROL; and</p> <p>5.2.6. The type of limitation represented by the stability limit or IROL (e.g., voltage collapse, angular stability).</p> <p>5.3. Each impacted Transmission Operator within its Reliability Coordinator Area, the value of the stability limits established pursuant to Requirement R4 and each IROL established pursuant to Requirement R1, in an agreed upon time frame necessary for inclusion in the Transmission Operator’s Operational Planning</p>	

**Standard: FAC-014-2 Establish and Communicate System Operating Limits**

Requirement in Approved Standard	Translation to New Standard or Other Action	Description and Change Justification
	<p>Analyses, Real-time monitoring, and Real-time Assessments.</p> <p>5.4. Each impacted Transmission Operator within its Reliability Coordinator Area, the information identified in Requirement R5 Parts 5.2.2 – 5.2.6 for each established stability limit and each established IROL, and any updates to that information within an agreed upon time frame necessary for inclusion in the Transmission Operator’s Operational Planning Analyses.</p> <p>5.5. Each requesting Transmission Operator within its Reliability Coordinator Area, requested SOL information for its Reliability Coordinator Area, on a mutually agreed upon schedule.</p> <p>5.6 Each impacted Generator Owner or Transmission Owner, within its Reliability Coordinator Area, with a list of their Facilities that have been identified as critical to the derivation of an (IROL) and its associated critical contingencies at least once every twelve calendar months.</p> <p><u>IRO-014-3, Requirement R1</u></p> <p>R1. Each Reliability Coordinator shall have and implement Operating Procedures, Operating Processes, or Operating Plans, for activities that</p>	

**Standard: FAC-014-2 Establish and Communicate System Operating Limits**

Requirement in Approved Standard	Translation to New Standard or Other Action	Description and Change Justification
	<p>require notification or coordination of actions that may impact adjacent Reliability Coordinator Areas, to support Interconnection reliability. These Operating Procedures, Operating Processes, or Operating Plans shall include, but are not limited to, the following:</p> <ul style="list-style-type: none"> <li>1.1. Criteria and processes for notifications.</li> <li>1.2. Energy and capacity shortages.</li> <li>1.3. Control of voltage, including the coordination of reactive resources.</li> <li>1.4. Exchange of information including planned and unplanned outage information to support its Operational Planning Analyses and Real-time Assessments.</li> <li>1.5. Provisions for periodic communications to support reliable operations.</li> </ul>	
<p><u>FAC-014-2, Requirement R5, R5.2</u></p> <p>R5.2 The Transmission Operator shall provide any SOLs it developed to its Reliability Coordinator and to the Transmission Service Providers that share its portion of the Reliability Coordinator Area.</p>	<p>1. <u>FAC-014-3, Requirement R3</u></p> <p><u>FAC-014-3, Requirement R3</u></p> <p>R3. The Transmission Operator shall provide its SOLs to its Reliability Coordinator.</p>	<p>The communication of SOLs from the TOP to its RC is preserved in FAC-014-3, Requirement R3.</p>

**Standard: FAC-014-2 Establish and Communicate System Operating Limits**

Requirement in Approved Standard	Translation to New Standard or Other Action	Description and Change Justification
<p><u>FAC-014-2, Requirement R5, R5.3 and R5.4</u></p> <p>R5.3 The Planning Authority shall provide its SOLs (including the subset of SOLs that are IROLs) to adjacent Planning Authorities, and to Transmission Planners, Transmission Service Providers, Transmission Operators and Reliability Coordinators that work within its Planning Authority Area.</p> <p>R5.4 The Transmission Planner shall provide its SOLs (including the subset of SOLs that are IROLs) to its Planning Authority, Reliability Coordinators, Transmission Operators, and Transmission Service Providers that work within its Transmission Planning Area and to adjacent Transmission Planners.</p>	<p>1. FAC-014-3, Requirements R7 2. TPL-001-4, Requirement R8</p> <p><u>FAC-014-3 Requirements R7</u> (Also see the translation above for Requirements R3 and R4)</p> <p><b>R7.</b> Each Planning Coordinator and each Transmission Planner shall annually communicate the following information for Corrective Action Plans developed to address any instability identified in its Planning Assessment of the Near-Term Transmission Planning Horizon to each impacted Transmission Operator and Reliability Coordinator. This communication shall include:</p> <p><b>7.1</b> The Corrective Action Plan developed to mitigate the identified instability, including any automatic control or operator-assisted actions (such as Remedial Action Schemes, under voltage load shedding, or any other planned mitigation actions);</p> <p><b>7.2</b> The type of instability addressed by the Corrective Action Plan (e.g. steady-state and/or transient voltage instability, angular</p>	<p>Provision of important planning study information to TOPs and RCs is preserved in FAC-014-3, Requirement R7, which requires the PC and TP to annually communicate information for Corrective Action Plans developed to address any instability identified in its Planning Assessments to each impacted TOP and RC. The subparts of Requirement R7 require the communication of key information that can be useful to the RC and TOP to establish stability limits and IROLs that will ultimately be used in real-time operations.</p> <p>TPL-001-4, Requirement R8 requires each PC and TP to distribute its Planning Assessment results to adjacent PCs and adjacent TPs within 90 calendar days of completing its Planning Assessment, and to any functional entity that has a reliability related need and submits a written request for the information within 30 days of such a request.</p> <p>With this requirement, any functional entity with a reliability-related need for a</p>



**Standard: FAC-014-2 Establish and Communicate System Operating Limits**

Requirement in Approved Standard	Translation to New Standard or Other Action	Description and Change Justification
	<p>instability including generating unit loss of synchronism, or unacceptable damping);</p> <p><b>7.3</b> The associated stability criteria violation requiring the Corrective Action Plan (e.g. violation of transient voltage response criteria or damping rate criteria);</p> <p><b>7.4</b> The planning event Contingency(ies) associated with the identified instability requiring the Corrective Action Plan;</p> <p><b>7.5</b> The System conditions and Facilities associated with the identified instability requiring the Corrective Action Plan.</p> <p><u>TPL-001-4, Requirement R8:</u></p> <p><b>R8.</b> Each Planning Coordinator and Transmission Planner shall distribute its Planning Assessment results to adjacent Planning Coordinators and adjacent Transmission Planners within 90 calendar days of completing its Planning Assessment, and to any functional entity that has a reliability related need and submits a written request for the information within 30 days of such a request.</p> <p><b>8.1.</b> If a recipient of the Planning Assessment results provides documented comments on the</p>	<p>PC's or TP's Planning Assessment can obtain that Planning Assessment. Requesting entities are then made aware of any system performance issues identified by these Planning Assessments.</p>

**Standard: FAC-014-2 Establish and Communicate System Operating Limits**

Requirement in Approved Standard	Translation to New Standard or Other Action	Description and Change Justification
	<p>results, the respective Planning Coordinator or Transmission Planner shall provide a documented response to that recipient within 90 calendar days of receipt of those comments.</p>	
<p><u>FAC-014-2, Requirement R6</u></p> <p>R6. The Planning Authority shall identify the subset of multiple contingencies (if any), from Reliability Standard TPL-003 which result in stability limits.</p> <p>R6.1 The Planning Authority shall provide this list of multiple contingencies and the associated stability limits to the Reliability Coordinators that monitor the facilities associated with these contingencies and limits.</p> <p>R6.2 If the Planning Authority does not identify any stability-related multiple contingencies, the Planning Authority shall so notify the Reliability Coordinator.</p>	<p><u>FAC-014-3, Requirement R7</u></p> <p>(See the Translation above for Requirements R5.3 and R5.4 )</p>	<p>FAC-014-3, Requirement R7 covers the content of FAC-014-2, Requirement R6.1 and improves upon it as follows:</p> <ul style="list-style-type: none"> <li>• FAC-014-3, Requirement R7 addresses not only the identification of multiple contingencies that result in stability criteria violation, but also address the key information RCs need to establish stability limits and IROLs used in operations. Unlike FAC-014-2, Requirement R6.1, the FAC-014-3, Requirement R7 ensures the type of instability, the associated stability criteria, the associated planning event contingencies, the associated system conditions &amp; Facilities, and Corrective Action Plans developed for its mitigation are</li> </ul>

**Standard: FAC-014-2 Establish and Communicate System Operating Limits**

Requirement in Approved Standard	Translation to New Standard or Other Action	Description and Change Justification
		<p>communicated by the PC to the appropriate TOP and RC.</p> <ul style="list-style-type: none"> <li>• FAC-014-2, Requirement R6, R6.2 is addressed by FAC-014-3, Requirement R7 because all instances of instability identified by the PC are to be communicated to the impacted TOP and RC. Further, it may be noted that FAC-014-2, Requirement R6, R6.2 is administrative in nature, given that the existing FAC-014-2, Requirement R6, R6.1 and proposed FAC-014-3, Requirement R7 both require communication of a defined set of stability related data. The absence of any communication of stability related data inherently implies the PC has not identified any instability and therefore has nothing to communicate.</li> </ul>

Exhibit D-4

Mapping Document  
IRO-008-3

## Mapping Document

### Project 2015-09 Establish and Communicate System Operating Limits

Standard IRO-008-3		
Requirement in Approved Standard	Translation to New Standard or Other Action	Description and Change Justification
IRO-008-2, Requirement R1	IRO-008-3, Requirement R1	No modifications made.
IRO-008-2, Requirement R2	IRO-008-3, Requirement R2	No modifications made.
IRO-008-2, Requirement R3	IRO-008-3, Requirement R3	No modifications made.
IRO-008-2, Requirement R4	IRO-008-3, Requirement R4	No modifications made.
<p>IRO-008-2, Requirement R5</p> <p><b>R5.</b> Each Reliability Coordinator shall notify impacted Transmission Operators and Balancing Authorities within its Reliability Coordinator Area, and other impacted Reliability Coordinators as indicated in its Operating Plan, when the results of a Real-time Assessment indicate an actual or expected condition that results in, or could result in, a</p>	<p>IRO-008-3, Requirement R5</p> <p><b>R5.</b> Each Reliability Coordinator shall notify, in accordance with its SOL methodology, impacted Transmission Operators and Balancing Authorities within its Reliability Coordinator Area, and other impacted Reliability Coordinators as indicated in its Operating Plan, when the results of a Real-time Assessment indicate an</p>	<p>The inclusion of the terminology “in accordance with its SOL methodology, aligns the notification requirements with the communication requirements identified in FAC-011-4 Requirement R7 around communication of SOL exceedances.</p> <p>Proposed FAC-011-4 R7 requires the RC to include in its SOL methodology a risk-based approach for determining how SOL exceedances are identified as part of Real-time monitoring and Real-time Assessments</p>

Standard IRO-008-3		
Requirement in Approved Standard	Translation to New Standard or Other Action	Description and Change Justification
System Operating Limit (SOL) or Interconnection Reliability Operating Limit (IROL) exceedance within its Wide Area. <i>[Violation Risk Factor: High] [Time Horizon: Same-Day Operations, Real-time Operations]</i>	actual or expected condition that results in, or could result in, a System Operating Limit (SOL) or an Interconnection Reliability Operating Limit (IROL) exceedance within its Wide Area. <i>[Violation Risk Factor: High] [Time Horizon: Same-Day Operations, Real-time Operations]</i>	must be communicated and if so, with what priority. This will ensure communication consistency regarding SOL exceedances within an RC’s area between the RC and its TOPs and BAs. Without the addition of this reference, there is no joint method for use by the RC and its TOPs and BAs when communicating with regard to SOL exceedances.
<p>IRO-008-2, Requirement R6</p> <p>Each Reliability Coordinator shall notify impacted Transmission Operators and Balancing Authorities within its Reliability Coordinator Area, and other impacted Reliability Coordinators as indicated in its Operating Plan, when the System Operating Limit (SOL) or Interconnection Reliability Operating Limit (IROL) exceedance identified in Requirement R5 has been prevented or mitigated. <i>[Violation Risk Factor:</i></p>	<p>IRO-008-3, Requirement R6</p> <p>Each Reliability Coordinator shall notify, in accordance with SOL methodology, impacted Transmission Operators and Balancing Authorities within its Reliability Coordinator Area, and other impacted Reliability Coordinators as indicated in its Operating Plan, when the System Operating Limit (SOL) or Interconnection Reliability Operating Limit (IROL) exceedance identified in Requirement R5 has been prevented or mitigated. <i>[Violation Risk Factor:</i></p>	<p>The inclusion of the terminology “in accordance with its SOL methodology, aligns the notification requirements with the communication requirements identified in FAC-011-4 Requirement R7 around communication of SOL exceedances.</p> <p>Proposed FAC-011-4 R7 requires the RC to include in its SOL methodology a risk-based approach for determining how SOL exceedances are identified as part of Real-time monitoring and Real-time Assessments must be communicated and if so, with what priority. This will ensure communication consistency regarding SOL exceedances</p>

Standard IRO-008-3		
Requirement in Approved Standard	Translation to New Standard or Other Action	Description and Change Justification
<i>Medium] [Time Horizon: Same-Day Operations, Real-time Operations]</i>	<i>Medium] [Time Horizon: Same-Day Operations, Real-time Operations]</i>	within an RC's area between the RC and its TOPs and BAs. Without the addition of this reference, there is no joint method for use by the RC and its TOPs and BAs when communicating with regard to SOL exceedances.

Exhibit D-5

Mapping Document  
TOP-001-6



## Mapping Document

### Project 2015-09 Establish and Communicate System Operating Limits

Standard TOP-001-6		
Requirement in Approved Standard	Translation to New Standard or Other Action	Description and Change Justification
TOP-001-5, Requirement R1	TOP-001-6, Requirement R1	No modifications made.
TOP-001-5, Requirement R2	TOP-001-6, Requirement R2	No modifications made.
TOP-001-5, Requirement R3	TOP-001-6, Requirement R3	No modifications made.
TOP-001-5, Requirement R4	TOP-001-6, Requirement R4	No modifications made.
TOP-001-5, Requirement R5	TOP-001-6, Requirement R5	No modifications made.
TOP-001-5, Requirement R6	TOP-001-6, Requirement R6	No modifications made.
TOP-001-5, Requirement R6	TOP-001-6, Requirement R7	No modifications made.
TOP-001-5, Requirement R8	TOP-001-6, Requirement R8	No modifications made.
TOP-001-5, Requirement R9	TOP-001-6, Requirement R9	No modifications made.
TOP-001-5, Requirement R10	TOP-001-6, Requirement R10	No modifications made.
TOP-001-5, Requirement R11	TOP-001-6, Requirement R11	No modifications made.

Standard TOP-001-6		
Requirement in Approved Standard	Translation to New Standard or Other Action	Description and Change Justification
TOP-001-5, Requirement R12	TOP-001-6, Requirement R12	No modifications made.
TOP-001-5, Requirement R13	TOP-001-6, Requirement R13	No modifications made.
TOP-001-5, Requirement R14	TOP-001-6, Requirement R14	No modifications made.
<p>TOP-001-5, Requirement R15</p> <p><b>R15.</b> Each Transmission Operator shall inform its Reliability Coordinator of actions taken to return the System to within limits when a SOL has been exceeded. <i>[Violation Risk Factor: Medium] [Time Horizon: Real-Time Operations]</i></p>	<p>TOP-001-6, Requirement R15</p> <p><b>R15.</b> Each Transmission Operator shall inform its Reliability Coordinator of actions taken to return the System to within limits when a SOL has been exceeded in accordance with its Reliability Coordinator’s SOL methodology. <i>[Violation Risk Factor: Medium] [Time Horizon: Real-Time Operations]</i></p>	<p>The inclusion of the terminology “in accordance with its SOL methodology, aligns the notification requirements with the communication requirements identified in FAC-011-4 Requirement R7 around communication of SOL exceedances.</p> <p>Proposed FAC-011-4 R7 requires the RC to include in its SOL methodology a risk-based approach for determining how SOL exceedances identified as part of Real-time monitoring and Real-time Assessments must be communicated and if so, with what priority. This will ensure communication consistency on SOL exceedances within an RC’s area between the RC and its TOPs. Without the addition of this reference, there is no joint method for use by the RC and TOP when communicating with regard to SOL exceedances.</p>

<b>Standard TOP-001-6</b>		
<b>Requirement in Approved Standard</b>	<b>Translation to New Standard or Other Action</b>	<b>Description and Change Justification</b>
TOP-001-5, Requirement R16	TOP-001-6, Requirement R16	No modifications made.
TOP-001-5, Requirement R17	TOP-001-6, Requirement R17	No modifications made.
TOP-001-5, Requirement R18	TOP-001-6, Requirement R18	No modifications made.
TOP-001-5, Requirement R19	TOP-001-6, Requirement R19	No modifications made.
TOP-001-5, Requirement R20	TOP-001-6, Requirement R20	No modifications made.
TOP-001-5, Requirement R21	TOP-001-6, Requirement R21	No modifications made.
TOP-001-5, Requirement R22	TOP-001-6, Requirement R22	No modifications made.
TOP-001-5, Requirement R23	TOP-001-6, Requirement R23	No modifications made.
TOP-001-5, Requirement R24	TOP-001-6, Requirement R24	No modifications made.

## Exhibit E

### Whitepaper on System Operating Limit Definition and Exceedance Clarification

# System Operating Limit Definition and Exceedance Clarification

The NERC-defined term System Operating Limit (SOL) is used extensively in the NERC Reliability Standards; however, there is much confusion with – and many widely varied interpretations and applications of – the SOL term. This whitepaper describes the standard drafting team’s (SDT) intent with regard to the SOL concept, and brings clarity and consistency to the notion of establishing SOLs, exceeding SOLs, and implementing Operating Plans to mitigate SOL exceedances.

## **System Operating Limit Definition Clarification:**

The approved definition of SOL as defined in the NERC Glossary of Terms is:

*The value (such as MW, MVar, Amperes, Frequency or Volts) that satisfies the most limiting of the prescribed operating criteria for a specified system configuration to ensure operation within acceptable reliability criteria. SOLs are based upon certain operating criteria. These include, but are not limited to:*

- *Facility Ratings (Applicable pre- and post- Contingency equipment or Facility ratings)*
- *Transient Stability Ratings (Applicable pre- and/or post-Contingency Stability Limits)*
- *Voltage Stability Ratings (Applicable pre- and/or post- Contingency Voltage Stability)*
- *System Voltage Limits (Applicable pre- and post-Contingency Voltage Limits)*

The proposed revised definition of SOL is:

*All Facility Ratings, System Voltage Limits, and stability limits, applicable to specified System configurations, used in Bulk Electric System operations for monitoring and assessing pre- and post-Contingency operating states.*

The concept of SOL determination is not complete without looking at the associated NERC FAC standards approved FAC-008-3, proposed FAC-011-4, and proposed FAC-014-3 and related TOP and IRO standards (proposed TOP-001-6 and IRO-008-3):

1. The purpose of approved FAC-008-3, which is applicable to both Generation and Transmission Owners, is to ensure that Facility Ratings used in the reliable planning and operation of the BES are determined based on technically sound principles. The standard requires both Generation Owners and Transmission Owners to have a documented Facility Ratings methodology and to establish Facility Ratings consistent with that methodology that respects the most limiting applicable Equipment Rating of the individual equipment that comprises that Facility. The scope of the Ratings addressed are required to include, as a minimum, both Normal and Emergency (short-

- term) Ratings (approved FAC-008-3, Requirement R3, part 3.4.2). A 24-hour continuous rating is an example of a Normal Rating; however, rating practices vary from entity to entity and may include ratings that vary with ambient temperature. Typical Emergency (short-term) Emergency Ratings have a finite duration of less than 24 hours (e.g., 4 hours, 2 hours, 1 hour, 30 minutes, or 15 minutes).
2. The purpose of proposed FAC-011-4, which is applicable to Reliability Coordinators, is to ensure that SOLs used in the reliable operation of the BES are determined based on an established methodology or methodologies. Proposed FAC-011-4 contains requirements that addresses each type of SOL: Facility Ratings, System Voltage Limits, and stability limits:
    - a. Requirement R2 requires that the Reliability Coordinator’s SOL methodology include the method for Transmission Operators to determine which owner-provided Facility Ratings (provided via FAC-008-3) are to be used in operations such that the Transmission Operator and its Reliability Coordinator use common Facility Ratings.
    - b. Requirement R3 requires that the Reliability Coordinator’s SOL methodology include the method for Transmission Operators to determine the System Voltage Limits to be used in operations. The subparts of requirement R3 contain several associated requirements.
    - c. Requirement R4 requires that the Reliability Coordinator’s SOL methodology include the method for determining the stability limits to be used in operations. The subparts of requirement R4 contain several associated requirements.
  3. Proposed FAC-011-4 requirement R6 contains the minimum framework for SOL exceedance determination to be used in the TOP and IRO standards. Specifically, requirement R6 requires the Reliability Coordinator’s SOL methodology to include, at a minimum, the following Bulk Electric System performance framework:
    - a. Part 6.1: System performance for no Contingencies demonstrates the following:
      - Part 6.1.1. Steady state flow through Facilities are within Normal Ratings; however, Emergency Ratings may be used when System adjustments to return the flow within its Normal Rating could be executed and completed within the specified time duration of those Emergency Ratings.
      - Part 6.1.2. Steady state voltages are within normal System Voltage Limits; however, emergency System Voltage Limits may be used when System adjustments to return the voltage within its normal System Voltage Limits could be executed and completed within the specified time duration of those emergency System Voltage Limits.
      - Part 6.1.3. Predetermined stability limits are not exceeded.
      - Part 6.1.4. Instability, Cascading or uncontrolled separation that adversely impact the reliability of the Bulk Electric System does not occur.<sup>1</sup>

---

<sup>1</sup> Stability evaluations and assessments of instability, Cascading, and uncontrolled separation can be performed using real-time stability assessments, predetermined stability limits or other offline analysis techniques.

- a. Part 6.2: System performance for the single Contingencies listed in Part 5.1 demonstrates the following:
    - i. Part 6.2.1: Steady state post-Contingency flow through Facilities within applicable Emergency Ratings. Steady state post-Contingency flow through a Facility must not be above the Facility's highest Emergency Rating.
    - ii. Part 6.2.2: Steady state post-Contingency voltages are within emergency System Voltage Limits.
    - iii. Part 6.2.3: The stability performance criteria defined in the Reliability Coordinator's SOL methodology are met<sup>1</sup>.
    - iv. Part 6.2.4. Instability, Cascading or uncontrolled separation that adversely impact the reliability of the Bulk Electric System does not occur<sup>1</sup>
  - b. Part 6.3: System performance for applicable Contingencies identified in Part 5.2 demonstrates that: instability, Cascading, or uncontrolled separation that adversely impact the reliability of the Bulk Electric System does not occur.
  - c. Part 6.4: In determining the System's response to any Contingency identified in Requirement R5, planned manual load shedding is acceptable only after all other available System adjustments have been made.
4. Proposed FAC-014-3, Requirement R2 requires that Transmission Operators establish SOLs for its portion of the Reliability Coordinator Area in accordance with its Reliability Coordinator's SOL methodology.
  5. Proposed TOP-001-6, Requirement R25 and IRO-008-3, Requirement R7 require Transmission Operators and Reliability Coordinators, respectively, to use the Reliability Coordinator's SOL methodology when performing Real-time Assessments, Real-time monitoring, and Operational Planning Analyses to determine SOL exceedances. The SOL exceedance framework is included in the SOL methodology via the proposed FAC-011-4 requirement R6 (above).
  6. The requirements within proposed FAC-011-4, when combined with the BES Exception Process which is designed to bring impactful facilities into the BES, ensure that all Facilities that can adversely impact BES reliability are either designated as part of the BES or otherwise incorporated into operations studies.

Some have interpreted the language in previous versions of FAC-011 to imply that the objective is to perform prior studies to determine a specific MW flow value (SOL) that ensures operation within the criteria specified in FAC-011, with the assumption being that if the system is operated within this pre-determined SOL value, then all of the pre- and post-Contingency requirements described in FAC-011 will be met. The SDT believes this approach may not capture the complete intent of the SOL concept within FAC-011, which is both:

1. To know the Facility Ratings, voltage limits, transient stability criteria, and voltage Stability criteria, and

2. To ensure that they are all observed in assessments of both the pre- and post-Contingency state when performing Operational Planning Analyses (OPA), Real-time Assessments (RTA), and Real-time monitoring.

It is important to understand the intent behind the language “the pre- and post-contingency state.” The pre-Contingency state is synonymous with the actual or initial state of the system. For example, for Real-time monitoring and Real-time Assessments, the pre-Contingency state refers to actual flows and voltages on the system as indicated by SCADA systems or state estimators at the time the assessment or monitoring occurs. For OPAs, the pre-Contingency state refers to the base case flows and voltages in the system models that are observed prior to simulating any Contingencies.

The post-Contingency state is a calculation or simulation of the expected state of the system if a Contingency were to occur. The post-Contingency state can be determined, or calculated, by analysis processes or tools such as Real-time Contingency Analysis (RTCA). Such tools calculate the flows and voltages on the system that are expected to occur based on simulated Contingencies. It is important to understand that when this document refers to the post-Contingency state or post-Contingency flows or voltages, it is referring to calculations based on analysis processes or tools. It is not referring to the state of the system after a Contingency event actually occurs. When a Contingency event actually occurs in Real-time operations, the system is now in a new state. The former post-Contingency state is now the new pre-Contingency state, and new RTAs then need to be executed to determine the new post-Contingency state based on these new conditions.

A primary focus of System Operators is to ensure reliable operations with regard to Facility Ratings, System Voltage Limits, and transient and voltage stability criteria for the pre- and post-Contingency state. In Real-time operations, any of these types of limits can be the most restrictive limit at any point in time in the pre- or post-Contingency state. For example, if an area or Facility of the BES is at no risk of encroaching upon stability or voltage limitations in the pre- or post-Contingency state, and the most restrictive limitations in that area are pre- or post-Contingency exceedance of thermal Facility Ratings, then the thermal Facility Ratings in that area are the most limiting SOLs. Conversely, if an area is not at risk of instability and no Facilities are approaching their thermal Facility Ratings, but the area is prone to pre- or post-Contingency low voltage conditions, then the System Voltage Limits in that area are the most limiting SOLs.

It is important to distinguish operating practices and strategies from the SOL itself. As stated earlier, a primary focus of System Operators is to ensure reliable operations with regard to Facility Ratings, System Voltage Limits, and transient and voltage stability criteria for the pre- and post-Contingency state. How an entity accomplishes this objective can vary depending on the planning strategies, operating practices, and mechanisms employed by that entity. For example, one Transmission Operator (TOP) may utilize line outage distribution factors or other similar calculations as a mechanism to ensure SOLs are not exceeded, while another may utilize advanced network applications to achieve the same reliability objective. To illustrate, a TOP may restrict flow over a major interface to a pre-determined value as a means by which to prevent a Contingency from causing a Facility to exceed its Emergency Rating. In this scenario, the restriction of flow on this interface can be considered as the Operating Plan to prevent exceeding a Facility



Rating. Similarly, a TOP might restrict flow on a Facility to ensure that voltages at a bus remain within System Voltage Limits. In this scenario the flow restriction can be considered as the Operating Plan employed to prevent exceeding a System Voltage Limit.

In order to ensure reliable operations, the following SOL performance must be maintained:

**1. Facility Ratings:**

In the pre- and post-Contingency state, operate within Facility capability by utilizing Normal and Emergency (short-term) Ratings, as applicable, within their associated time parameters.

**2. System Voltage Limits:**

In the pre-Contingency and post-Contingency state, operate within normal System Voltage Limits and emergency System Voltage Limits, as applicable, within their associated time parameters.

**3. Stability Limits:**

Stability limits are typically established to address stability phenomena in the transient or the steady-state timeframes. Stability limits are unique in that they typically are established to prevent a Contingency or a specific set of Contingencies from resulting in the particular type of instability identified in studies. Proposed FAC-011-4 requirement R4, part 4.1 requires the RC's SOL methodology to include and specify stability performance criteria for steady-state voltage stability, transient voltage response, angular stability, and System damping. Part 4.2 requires stability limits to be established to meet these prescribed stability performance criteria. For example, a study might indicate that a three-phase fault at a particular location results in exceeding the transient damping criteria threshold. A transient stability limit would be established to prevent a fault at that location from the unacceptable damping.

**Transient Stability Limits:**

Transmission Operators establish transient Stability limits to prevent intra-area instability, inter-area instability, or tripping of Facilities due to out-of-step conditions. Transient Stability limits are typically defined as the maximum power transfer or loading level that ensures critical transient reliability criteria are met. Calculated flows must be maintained within appropriate pre- and/or post-Contingency limits.

**Voltage Stability Limits:**

Transmission Operators typically stress Transmission Paths/Interfaces or load areas to the reasonably expected maximum transfer conditions or area load levels to determine whether steady state voltage Stability limits exist. Voltage Stability limits are typically defined as the maximum power transfer or load level that ensures voltage Stability criteria are met. Calculated flows must be maintained within appropriate pre- and/or post-Contingency limits.

**System Operating Limit Exceedance Clarification:**

The combination of requirements contained within the proposed FAC and the proposed and approved TOP and IRO standards, as well as the use of defined terms contained within those standards such as OPA, RTA, and Operating Plans when executed properly result in maintaining reliable BES performance.

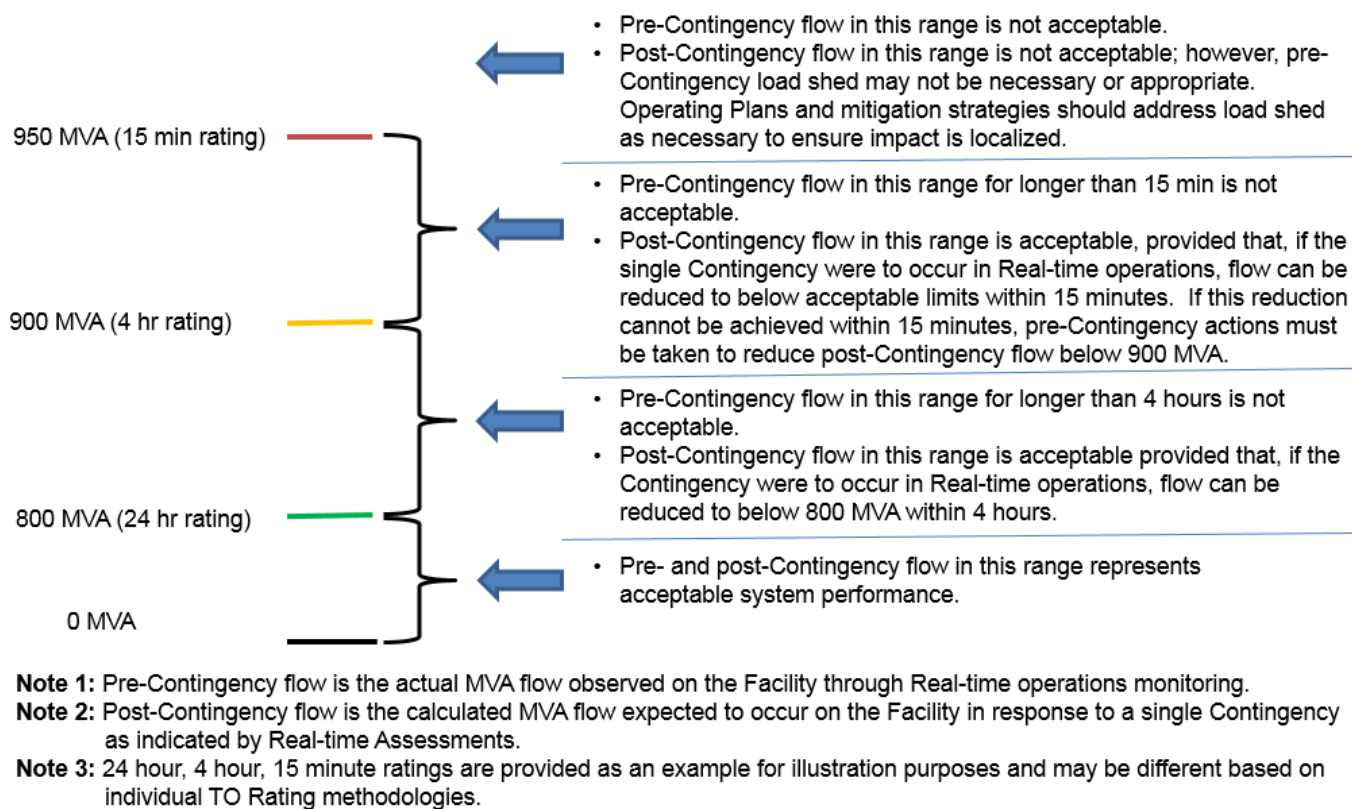
Specifically,

1. FAC standards require clear determination of Facility Ratings (approved FAC-008-3) and describe a performance framework for the pre- and post-Contingency state (proposed FAC-011-4 requirement R6) for SOL exceedance determinations.
2. TOP-001-6, Requirement R13 requires that each Transmission Operator perform a Real-time Assessment at least once every 30 minutes.
3. TOP-001-6, Requirement R25 requires that each Transmission Operator shall use the applicable Reliability Coordinator's SOL methodology when determining SOL exceedances for Real-time Assessments, Real-time monitoring, and Operational Planning Analysis.
4. TOP-002-4, Requirement R2 requires that each Transmission Operator have an Operating Plan to address potential SOL exceedances identified as a result of its Operational Planning Analysis.
5. TOP-001-6, Requirement R14 requires the Transmission Operator to initiate Operating Plan(s) to mitigate SOL exceedances.
6. IRO-008-3, Requirement R7 requires that each Reliability Coordinator shall use its SOL methodology when determining SOL exceedances for Real-time Assessments, Real-time monitoring, and Operational Planning Analysis.

### **Facility Rating Exceedance**

Facility Ratings include Normal Ratings and one or more Emergency Ratings. While Normal Ratings represent loading values that the facility can support or withstand through the daily demand cycles without loss of equipment life, Emergency Ratings allow for higher facility loading that can occur for a finite period of time and assumes acceptable loss of equipment life or other acceptable physical or safety limitations. Acceptable Facility Rating exceedance is a function of the available limit set and the magnitude of pre- or post-Contingency flows in relation to those limits as observed in Real-time monitoring or Real-time Assessments. The System Operator's goal with respect to Facility Rating exceedances is to take action as necessary, making use of both Normal Ratings and Emergency Ratings per the associated Operating Plans, to prevent equipment damage, to avoid public safety risks, and to mitigate other potential reliability impacts. Waiting to implement Operating Plans until after the time period associated with next highest Emergency Rating has been exceeded would not meet this goal. Figure 1 illustrates an SOL Performance Summary for Facility Ratings.

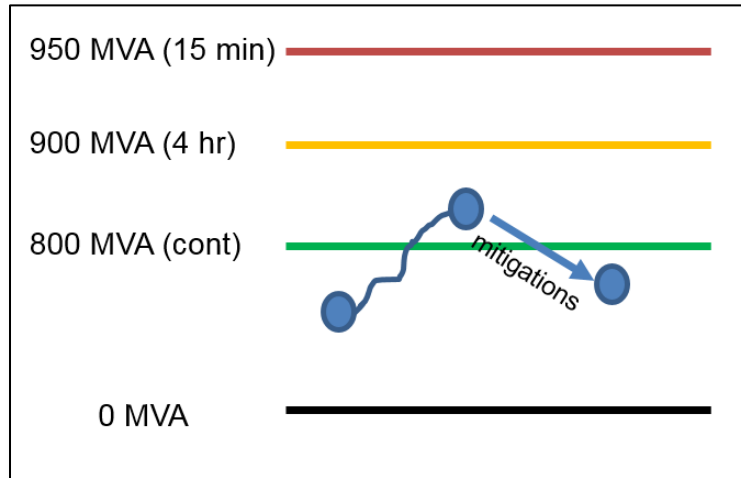
# SOL Performance Summary



**Figure 1. Facility Rating System Operating Limit Performance Summary**

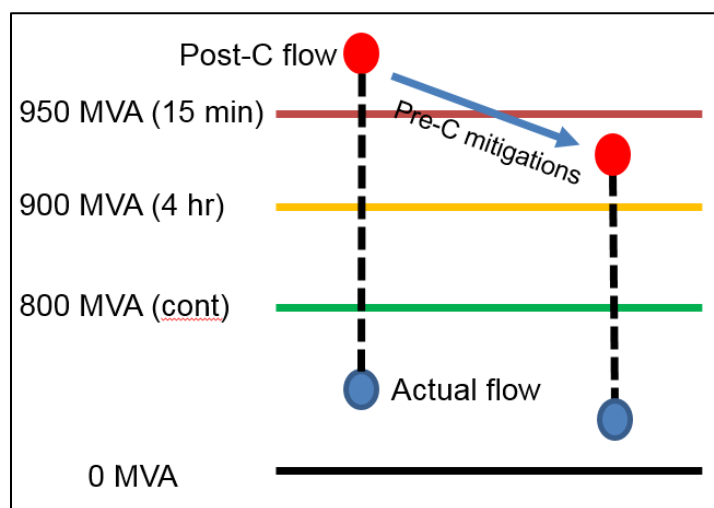
The following example scenarios describe appropriate operator action with respect to Figure 1:

- Example 1 Scenario** - System loads are increasing and actual flow on the line exceeds 800 MVA as shown in Figure 2. The System Operator is expected to take actions as necessary in accordance with the Operating Plan to ensure that flow is reduced to below 800 MVA within 4 hours. The Operating Plan may not require immediate operator action if loads are expected to decrease within the next hour as an example. In this case, the Operating Plan might require the TOP to monitor the flow and include other mitigating actions if the loading does not decrease as expected so that flow can be reduced to within the 800 MVA limit prior to the expiration of the 4 hours (assuming that Real-time Contingency Analysis (RTCA) does not indicate that a Contingency would result in this Facility exceeding the 950 MVA rating.) It is important to state that waiting until 3:45 min into a 4-hour rating to take actions might use up equipment life. So, while it is acceptable operation for system performance, it may not be acceptable operation for the equipment owner to make use of the full 4-hour rating if actions were available to be taken.



**Figure 2. Example 1 Scenario – Pre-Contingency State**

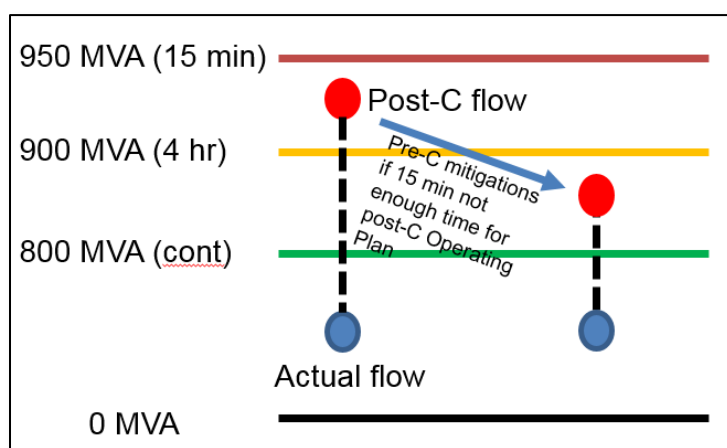
2. **Example 2 Scenario** - Flow on the line is 500 MVA. RTCA indicates that a single Contingency elsewhere in the system would cause flow on the line to immediately jump to 975 MVA. This condition represents unacceptable system performance for the post-Contingency state. Accordingly, the System Operator is expected to take action (pre-Contingency mitigation action) to reduce the post-Contingency flow such that RTCA no longer indicates that flow on this line would jump to a value higher than 950 MVA if the Contingency were to occur. Reference Figure 3 below for a pictorial of this scenario. In cases where post-Contingency flow exceeds the highest available Facility Rating as shown in Figure 1, post-Contingency Operating Plans are not adequate, and TOPs are expected to take pre-Contingency action to relieve the condition (including redispatch, reconfiguration, and making adjustments to the uses of the transmission system); however, the operating condition may not warrant shedding load pre-Contingency to relieve the condition. Pre-Contingency Load shed is generally utilized as a last resort in conditions where the next Contingency could result in Cascading or widespread instability. An entity's Operating Plan is expected to define when it is appropriate to shed Load pre-Contingency versus post-Contingency while ensuring the BES remains N-1 stable.



**Figure 3. Example 2 Scenario – Unacceptable Post-Contingency State**

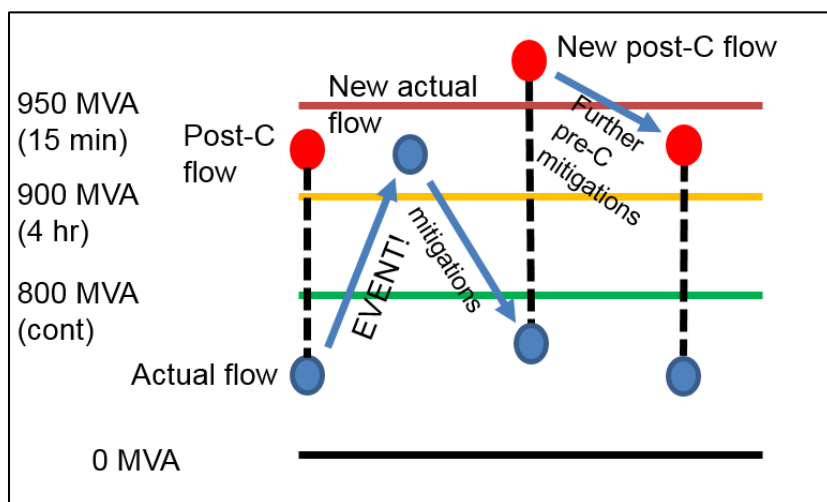
3. **Example 3 Scenario** - Flow on the line is 500 MVA. RTCA indicates that if a single Contingency elsewhere in the system were to occur, flow on this line would immediately jump to 925 MVA. If the Contingency were to occur, the System Operator would have 15 minutes to reduce flow on this line to an acceptable level. The acceptable level could be either 900 MVA or 800 MVA depending on how the line is rated based on the Transmission Owner's Facility Ratings methodology. If this information is not known, the System Operator should assume that flow would need to be reduced to below 800 MVA. If the Contingency actually occurs and the flow is not reduced to an acceptable level within 15 minutes, facilities could be damaged, or worse, the line could sag creating a public safety hazard. For this scenario it is important for reliability that any post-Contingency Operating

Plans (i.e., any Operating Plans that are employed after an actual Contingency event occurs) can be fully implemented to reduce flows within 800MVA within 15 minutes to avoid equipment damage or unsafe line sagging. If it is determined that a post-Contingency Operating Plan is viable, then it is acceptable to remain in this state and to wait to take mitigating action if the Contingency were to actually occur. Operators would then increase monitoring of this Facility as part of the Operating Plan and to be prepared to take action if the Contingency event actually occurs. If it is determined that the post-Contingency Operating Plan is unable to reduce flow to acceptable levels within 15 minutes, then the System Operator must take pre-Contingency actions to reduce post-Contingency flows to below 900 MVA (i.e., take pre-Contingency action that result in RTCA indicating that a Contingency would result in flows below 900 MVA). Reference Figure 4 below for a pictorial of this scenario.



**Figure 4. Example 3 Scenario – Post-Contingency State May Require pre-Contingency Mitigation**

4. **Example 4 Scenario** - Similar to scenario 3, flow on the line is 500 MVA. RTCA indicates that if a single Contingency elsewhere in the system were to occur, flow on this line would immediately jump to 925 MVA. The worst single Contingency event actually occurs, and as expected, flow on this line immediately jumps to 925 MVA. The System Operator has 15 minutes to reduce flow on this line to an acceptable level. If flow is not reduced to an acceptable level within 15 minutes, facilities could be damaged, or worse, the line could sag creating a public safety hazard. After the Contingency event actually occurs, the system is in a new state. Real-time Assessments are now performed on the new system state. The Real-time Assessment against this new state now indicates that if a Contingency elsewhere in the system were to occur, flow on this line would immediately jump to 975 MVA. At this point further mitigations must be made to bring post-Contingency flows below 950 MVA. Reference Figure 5 below for a pictorial of this scenario.

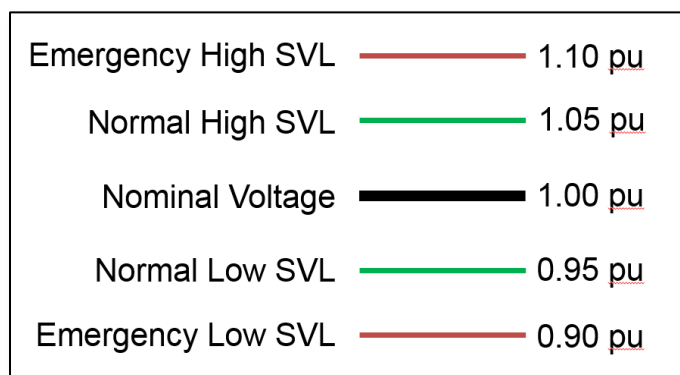


**Figure 5. Example 4 Scenario – An Actual Contingency Event Occurs**

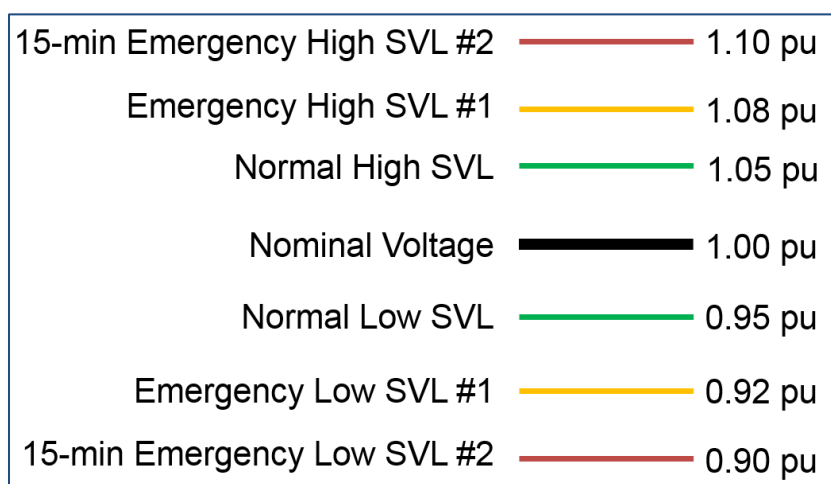
### **Steady State Voltage Limit Exceedance**

SOL performance for System Voltage Limits is determined through Operational Planning Analyses and through Real-time monitoring and Real-time Assessments. Normal and emergency System Voltage Limits are required to be established by the TOP in accordance with the RC’s SOL methodology. FAC-011-4 Requirement R3 requires that the RC’s SOL methodology contain specific requirements associated with the establishment of System Voltage Limits. Per FAC-011-4 Requirement R3, System Voltage Limits are required respect undervoltage load shedding relay settings and UVLS, to address coordination and common use of System Voltage Limits with neighbors, and to respect any equipment voltage limitations specified in the Transmission Owner’s or the Generation Owner’s Facility Ratings methodology per approved FAC-008-3.

Normal System Voltage Limits are typically applicable for the pre-Contingency state while emergency System Voltage Limits are normally applicable for the post-Contingency state. SOL exceedance with respect to these System Voltage Limits occurs when either actual bus voltage is outside acceptable pre-Contingency (normal) System Voltage Limits, or when Real-time Assessments indicate that bus voltages are expected to fall outside emergency System Voltage Limits in response to a Contingency event. System Voltage Limits are often established as normal and emergency high and low limits as depicted in the example in Figure 6. However, some TOPs might implement time-based System Voltage Limits as shown in the example in Figure 7. Any System Voltage Limit must be established in accordance with its RC’s SOL methodology. Real-time Assessments should recognize the impact of automatically controlled reactive devices and whether or not those devices are sufficient without manual operator action for maintaining voltages within System Voltage Limits pre- or post-Contingency.



**Figure 6. Example of a System Voltage Limit Set**



**Figure 7. Example of a System Voltage Limit Set Utilizing Time-Based Values**

**Stability Limit Exceedance**

Transient and voltage stability limits can be determined through prior studies, or they can be determined in Real-time.

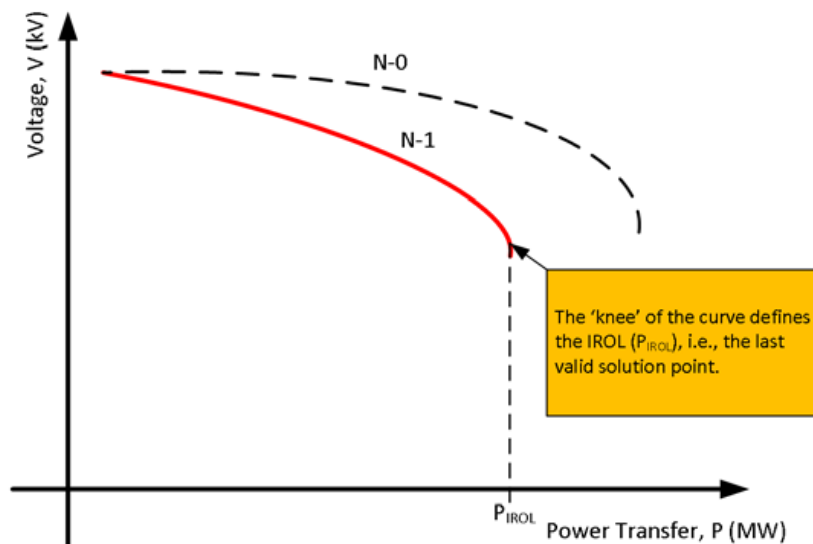
Transient Stability limits are often expressed as flow limits on a defined interface or cut plane that, if operated within, ensures that the system will remain transiently stable should the identified limiting Contingency(s) occur. Transient instability could take several forms, including undamped oscillations, or angular instability resulting in portions of the system losing synchronism.

Though voltage Stability limits can be determined, expressed, and monitored in several ways, the general principle is universal – voltage Stability limits are intended to ensure that the system does not experience voltage collapse in the pre- or post-Contingency state.

SOL exceedance for stability limits occurs when the system enters into an operating state where the next Contingency could result in transient or voltage instability. Stability limits are defined to identify the point



at which this would occur. Operating within defined stability limits prevents the associated Contingency (ies) from resulting in instability. Figure 8 depicts a wide-area’s voltage Stability performance exceeds an SOL that qualifies as an IROL. In this example, the SOL (IROL) exceedance occurs when power transfers over the monitored Facility(s) exceeds the  $P_{IROL}$  value. Note - A localized voltage collapse may not qualify as an IROL.



**Figure 8. Voltage Stability System Operating Limit Performance Summary**

**SOL Exceedance and Operating Plans:**

SOL exceedances occur when the performance framework described in proposed FAC-011-4 Requirement R6 is not being met; in Real-time operations, SOL exceedances are determined through Real-time monitoring and Real-time Assessments, while in the day-ahead space, potential SOL exceedances are determined through Operational Planning Analyses. For Facility Ratings and System Voltage Limits, SOL exceedances are identified through the evaluation of the pre-Contingency state and through an evaluation of Contingencies against that state. For stability limits, SOL exceedances are identified through system monitoring against defined stability limits or through the evaluation of stability performance against defined stability performance criteria.

When an SOL is being exceeded in Real-time operations, the Transmission Operator is required to implement mitigating strategies consistent with its Operating Plan(s). Operating Plans can include specific Operating Procedures or more general Operating Processes. Operating Plans include both pre- and post-Contingency mitigation plans/strategies. Pre-Contingency mitigation plans/strategies are actions that are implemented before the Contingency occurs to prevent the potential negative impacts on reliability of the Contingency. Post-Contingency mitigation plans/strategies are actions that are implemented after the Contingency occurs to bring the system back within limits. Operating Plans contain details to include appropriate timelines to escalate the level of mitigating plans/strategies to ensure acceptable BES performance is maintained, preventing SOL exceedances from escalating to a condition where the next Contingency could result in System instability, Cascading, or uncontrolled separation. Operating Plan(s)

must include the appropriate time element to return the system to within acceptable Normal and Emergency (short-term) Ratings and/or SOLs identified above.

An example of a general Operating Plan is shown in Table 1.

Thermal SOL Limit Exceeded	Pre-Contingency (actual) Loading	Post-Contingency (calculated) Loading
Normal (24 hr)	Reconfiguration actions, Redispatch actions, emergency procedures except Load shed consistent with timelines identified in the specific Operating Plan.	Trend – continue to monitor. Take reconfiguration actions to prevent Contingency from exceeding emergency limit consistent with timelines identified in the specific Operating Plan.
Emergency (4 hr)	All of the above plus Load shed only if necessary and appropriate to control loading below 4 hr Emergency Rating consistent with timelines identified in the specific Operating Plan.	Use available effective actions and emergency procedures except Load shed consistent with timelines identified in the specific Operating Plan.
Emergency (15 min)	All of the above plus Load shed to control loading below 15 min Emergency Rating consistent with timelines identified in the specific Operating Plan.	Take action (reconfigure, redispatch, etc. per the specific Operating Plan) to address the unacceptable post-Contingency condition. Load shed only if necessary and appropriate to avoid post-Contingency Cascading consistent with timelines identified in the specific Operating Plan.

**Table 1. Operating Plan Example**

**APPLICABLE DEFINITIONS**

**Real-time Assessment** – An evaluation of system conditions using Real-time data to assess existing (pre-Contingency) and potential (post-Contingency) operating conditions. The assessment shall reflect applicable inputs including, but not limited to: load, generation output levels, known Protection System and Special Protection System status or degradation, Transmission outages, generator outages, Interchange, Facility Ratings, and identified phase angle and equipment limitations. (Real-time Assessment may be provided through internal systems or through third-party services.)

**Operational Planning Analysis** – An evaluation of projected system conditions to assess anticipated (pre-Contingency) and potential (post-Contingency) conditions for next-day operations. The evaluation shall reflect applicable inputs including, but not limited to: load forecasts, generation output levels, Interchange, known Protection System and Special Protection System status or degradation, Transmission outages, generator outages, Facility Ratings, and identified phase angle and equipment limitations. (Operational Planning Analysis may be provided through internal systems or through third-party services.)

Changes made to the definitions of Real-time Assessment and Operational Planning Analysis were made in order to respond to issues raised in [NOPR](#) paragraphs 55, 73, and 74 dealing with analysis of SOLs in all time horizons, questions on Protection Systems and Special Protection Systems in NOPR paragraph 78, and recommendations on phase angles from the SW Outage Report (recommendation 27). The intent of such changes is to ensure that Real-time Assessments and Operational Planning Analysis contain sufficient details to result in an appropriate level of situational awareness. Some examples include: 1) analyzing phase angles which may result in the implementation of an Operating Plan to adjust generation or curtail transactions so that a Transmission facility may be returned to service, or 2) evaluating the impact of a modified Contingency resulting from the status change of a Special Protection Scheme from enabled/in-service to disabled/out-of-service.

**Operating Plan** – A document that identifies a group of activities that may be used to achieve some goal. An Operating Plan may contain Operating Procedures and Operating Processes. A company-specific system restoration plan that includes an Operating Procedure for black-starting units, Operating Processes for communicating restoration progress with other entities, etc., is an example of an Operating Plan.

**Operating Process** – A document that identifies general steps for achieving a generic operating goal. An Operating Process includes steps with options that may be selected depending upon Real-time conditions. A guideline for controlling high voltage is an example of an Operating Process.

**Operating Procedure** – A document that identifies specific steps or tasks that should be taken by one or more specific operating positions to achieve specific operating goal(s). The steps in an Operating Procedure should be followed in the order in which they are presented, and should be performed by the position(s) identified. A document that lists the specific steps for a System Operator to take in removing a specific transmission line from service is an example of an Operating Procedure.

## Time Horizons

When establishing a time horizon for each requirement, the following criteria should be used:

- **Long-term Planning** – a planning horizon of one year or longer.
- **Operations Planning** – operating and resource plans from day-ahead, up to and including seasonal.
- **Same-Day Operations** – routine actions required within the timeframe of a day, but not Real-time.
- **Real-time Operations** – actions required within one hour or less to preserve the reliability of the Bulk Electric System.

**Facility Rating** – The maximum or minimum voltage, current, frequency, or real or reactive power flow through a facility that does not violate the applicable equipment rating of any equipment comprising the facility.

**Normal Rating** – The rating as defined by the equipment owner that specifies the level of electrical loading, usually expressed in megawatts (MW) or other appropriate units that a system, facility, or element can support or withstand through the daily demand cycles without loss of equipment life.

**Emergency Rating** – The rating as defined by the equipment owner that specifies the level of electrical loading or output, usually expressed in megawatts (MW) or Mvar, or other appropriate units, that a system, facility, or element can support, procedure, or withstand for a finite period. The rating assumes acceptable loss of equipment life or other physical or safety limitations for the equipment involved.

## Exhibit G-1

Analysis of Violation Risk Factors and Violation Severity Levels  
FAC-011-4

# Violation Risk Factor and Violation Severity Level Justifications

## FAC-011-4 System Operating Limits Methodology for the Operations Horizon

This document provides the standard drafting team's (SDT's) justification for assignment of violation risk factors (VRFs) and violation severity levels (VSLs) for each requirement in Reliability Standard FAC-011-4 System Operating Limits (SOL) Methodology for the Operations Horizon. Each requirement is assigned a VRF and a VSL. These elements support the determination of an initial value range for the Base Penalty Amount regarding violations of requirements in FERC-approved Reliability Standards, as defined in the Electric Reliability Organizations Sanction Guidelines. The SDT applied the following NERC criteria and FERC Guidelines when developing the VRFs and VSLs for the requirements.

### NERC Criteria for Violation Risk Factors

#### High Risk Requirement

A requirement that, if violated, could directly cause or contribute to Bulk Electric System instability, separation, or a cascading sequence of failures, or could place the Bulk Electric System at an unacceptable risk of instability, separation, or cascading failures; or, a requirement in a planning time frame that, if violated, could, under emergency, abnormal, or restorative conditions anticipated by the preparations, directly cause or contribute to Bulk Electric System instability, separation, or a cascading sequence of failures, or could place the Bulk Electric System at an unacceptable risk of instability, separation, or cascading failures, or could hinder restoration to a normal condition.

#### Medium Risk Requirement

A requirement that, if violated, could directly affect the electrical state or the capability of the Bulk Electric System, or the ability to effectively monitor and control the Bulk Electric System. However, violation of a medium risk requirement is unlikely to lead to Bulk Electric System instability, separation, or cascading failures; or, a requirement in a planning time frame that, if violated, could, under emergency, abnormal, or restorative conditions anticipated by the preparations, directly and adversely affect the electrical state or capability of the Bulk Electric System, or the ability to effectively monitor, control, or restore the Bulk Electric System. However, violation of a medium risk requirement is unlikely, under emergency, abnormal, or restoration conditions anticipated by the preparations, to lead to Bulk Electric System instability, separation, or cascading failures, nor to hinder restoration to a normal condition.

## **Lower Risk Requirement**

A requirement that is administrative in nature and a requirement that, if violated, would not be expected to adversely affect the electrical state or capability of the Bulk Electric System, or the ability to effectively monitor and control the Bulk Electric System; or, a requirement that is administrative in nature and a requirement in a planning time frame that, if violated, would not, under the emergency, abnormal, or restorative conditions anticipated by the preparations, be expected to adversely affect the electrical state or capability of the Bulk Electric System, or the ability to effectively monitor, control, or restore the Bulk Electric System.

## **FERC Guidelines for Violation Risk Factors**

### **Guideline (1) – Consistency with the Conclusions of the Final Blackout Report**

FERC seeks to ensure that VRFs assigned to Requirements of Reliability Standards in these identified areas appropriately reflect their historical critical impact on the reliability of the Bulk-Power System. In the VSL Order, FERC listed critical areas (from the Final Blackout Report) where violations could severely affect the reliability of the Bulk-Power System:

- Emergency operations
- Vegetation management
- Operator personnel training
- Protection systems and their coordination
- Operating tools and backup facilities
- Reactive power and voltage control
- System modeling and data exchange
- Communication protocol and facilities
- Requirements to determine equipment ratings
- Synchronized data recorders
- Clearer criteria for operationally critical facilities
- Appropriate use of transmission loading relief.

**Guideline (2) – Consistency within a Reliability Standard**

FERC expects a rational connection between the sub-Requirement VRF assignments and the main Requirement VRF assignment.

**Guideline (3) – Consistency among Reliability Standards**

FERC expects the assignment of VRFs corresponding to Requirements that address similar reliability goals in different Reliability Standards would be treated comparably.

**Guideline (4) – Consistency with NERC’s Definition of the Violation Risk Factor Level**

Guideline (4) was developed to evaluate whether the assignment of a particular VRF level conforms to NERC’s definition of that risk level.

**Guideline (5) – Treatment of Requirements that Co-mingle More Than One Obligation**

Where a single Requirement co-mingles a higher risk reliability objective and a lesser risk reliability objective, the VRF assignment for such Requirements must not be watered down to reflect the lower risk level associated with the less important objective of the Reliability Standard.



## NERC Criteria for Violation Severity Levels

VSLs define the degree to which compliance with a requirement was not achieved. Each requirement must have at least one VSL. While it is preferable to have four VSLs for each requirement, some requirements do not have multiple “degrees” of noncompliant performance and may have only one, two, or three VSLs.

VSLs should be based on NERC’s overarching criteria shown in the table below:

Lower VSL	Moderate VSL	High VSL	Severe VSL
The performance or product measured almost meets the full intent of the requirement.	The performance or product measured meets the majority of the intent of the requirement.	The performance or product measured does not meet the majority of the intent of the requirement, but does meet some of the intent.	The performance or product measured does not substantively meet the intent of the requirement.

## FERC Order of Violation Severity Levels

The FERC VSL guidelines are presented below, followed by an analysis of whether the VSLs proposed for each requirement in the standard meet the FERC Guidelines for assessing VSLs:

### Guideline (1) – Violation Severity Level Assignments Should Not Have the Unintended Consequence of Lowering the Current Level of Compliance

Compare the VSLs to any prior levels of non-compliance and avoid significant changes that may encourage a lower level of compliance than was required when levels of non-compliance were used.

### Guideline (2) – Violation Severity Level Assignments Should Ensure Uniformity and Consistency in the Determination of Penalties

A violation of a “binary” type requirement must be a “Severe” VSL.

Do not use ambiguous terms such as “minor” and “significant” to describe noncompliant performance.

### Guideline (3) – Violation Severity Level Assignment Should Be Consistent with the Corresponding Requirement

VSLs should not expand on what is required in the requirement.

**Guideline (4) – Violation Severity Level Assignment Should Be Based on A Single Violation, Not on A Cumulative Number of Violations**

Unless otherwise stated in the requirement, each instance of non-compliance with a requirement is a separate violation. Section 4 of the Sanction Guidelines states that assessing penalties on a per violation per day basis is the “default” for penalty calculations.

<b>VRF Justifications for FAC-011-4 Requirement R1</b>	
<b>Proposed VRF</b>	<b>Medium</b>
<b>FERC VRF G1 Discussion</b> Guideline 1- Consistency with Blackout Report	The VRF is consistent with the conclusions of the final Blackout Report.
<b>FERC VRF G2 Discussion</b> Guideline 2- Consistency within a Reliability Standard	The requirement has no sub-requirements so a single VRF was assigned.
<b>FERC VRF G3 Discussion</b> Guideline 3- Consistency among Reliability Standards	A VRF of medium for this requirement is consistent with approved Reliability Standard FAC-008-3, Requirement R1.
<b>FERC VRF G4 Discussion</b> Guideline 4- Consistency with NERC Definitions of VRFs	Not having a methodology for establishing SOLs has the potential unintended consequence of creating inconsistencies in establishing SOLs which could directly affect the electrical state or the capability of the Bulk Electric System (BES), or the ability to effectively monitor and control the BES. However, violation of this requirement is unlikely, under emergency, abnormal, or restoration conditions anticipated by the preparations, to lead to BES instability, separation, or cascading failures, nor to hinder restoration to a normal condition.
<b>FERC VRF G5 Discussion</b> Guideline 5- Treatment of Requirements that Co-	The requirement contains one objective, therefore, a single VRF is assigned.

mingle More than One Obligation			
VSLs for FAC-011-4, Requirement R1			
Lower	Moderate	High	Severe
N/A	N/A	N/A	The Reliability Coordinator did not have a SOL methodology for establishing SOLs within its Reliability Coordinator Area.

**VSL Justifications for FAC-011-4, Requirement R1**

<p><b>FERC VSL G1</b>          Violation Severity Level Assignments Should Not Have the Unintended Consequence of Lowering the Current Level of Compliance</p>	<p>The requirement does not have elements or quantities to evaluate degrees of compliance. The requirement is binary, and therefore, a VSL of Severe is assigned for non-compliance.</p>
<p><b>FERC VSL G2</b>          Violation Severity Level Assignments Should Ensure Uniformity and Consistency in the Determination of Penalties   <u>Guideline 2a:</u> The Single Violation Severity Level Assignment Category for "Binary" Requirements Is Not Consistent   <u>Guideline 2b:</u> Violation Severity Level Assignments that Contain Ambiguous Language</p>	<p>The requirement does not have elements or quantities to evaluate degrees of compliance. The requirement is binary, and therefore, a VSL of Severe is assigned for non-compliance.</p> <p>The requirement is clear and does not contain any ambiguous language.</p>
<p><b>FERC VSL G3</b>          Violation Severity Level Assignment Should Be Consistent with the Corresponding Requirement</p>	<p>The proposed VSL is worded consistently with the corresponding requirement.</p>

**FERC VSL G4**

Violation Severity Level  
Assignment Should Be Based  
on A Single Violation, Not on  
A Cumulative Number of  
Violations

The proposed VSL is not based on a cumulative number of violations.

**VRF Justifications for FAC-011-4 Requirement R2**

Proposed VRF	Medium
<p><b>FERC VRF G1 Discussion</b>            Guideline 1- Consistency with Blackout Report</p>	<p>The VRF is consistent with the conclusions of the final Blackout Report.</p>
<p><b>FERC VRF G2 Discussion</b>            Guideline 2- Consistency within a Reliability Standard</p>	<p>The requirement has no sub-requirements so a single VRF was assigned.</p>
<p><b>FERC VRF G3 Discussion</b>            Guideline 3- Consistency among Reliability Standards</p>	<p>A VRF of medium for this requirement is consistent with approved Reliability Standard FAC-008-3, Requirements R2 and R3.</p>
<p><b>FERC VRF G4 Discussion</b>            Guideline 4- Consistency with NERC Definitions of VRFs</p>	<p>The establishment of improper Facility Ratings could directly affect the electrical state or the capability of the BES, or the ability to effectively monitor and control the BES. However, violation of this requirement is unlikely, under emergency, abnormal, or restoration conditions anticipated by the preparations, to lead to BES instability, separation, or cascading failures, nor to hinder restoration to a normal condition.</p>
<p><b>FERC VRF G5 Discussion</b>            Guideline 5- Treatment of Requirements that Co-mingle More than One Obligation</p>	<p>The requirement contains one objective, therefore, a single VRF is assigned.</p>

**VSLs for FAC-011-4, Requirement R2**

Lower	Moderate	High	Severe
N/A	N/A	<p>The Reliability Coordinator included in its SOL methodology the method for Transmission Operators to determine the applicable owner-provided Facility Ratings to be used in operations but the method did not address the use of common Facility Ratings between the Reliability Coordinator and the Transmission Operators in its Reliability Coordinator Area.</p>	<p>The Reliability Coordinator did not include in its SOL methodology the method for Transmission Operators to determine the applicable owner-provided Facility Ratings to be used in operations.</p>

**VSL Justifications for FAC-011-4, Requirement R2**

<p><b>FERC VSL G1</b>          Violation Severity Level Assignments Should Not Have the Unintended Consequence of Lowering the Current Level of Compliance</p>	<p>The requirement maps to the previously approved Requirement R1 sub-requirement R1.2. Therefore, the proposed VSLs do not have the unintended consequence of lowering compliance.</p>
<p><b>FERC VSL G2</b>          Violation Severity Level Assignments Should Ensure Uniformity and Consistency in the Determination of Penalties   <u>Guideline 2a</u>: The Single Violation Severity Level Assignment Category for "Binary" Requirements Is Not Consistent   <u>Guideline 2b</u>: Violation Severity Level Assignments that Contain Ambiguous Language</p>	<p>The proposed VSLs are not binary and do not use any ambiguous terminology, thereby supporting uniformity and consistency in the determination of similar penalties for similar violations.</p>
<p><b>FERC VSL G3</b>          Violation Severity Level Assignment Should Be Consistent with the Corresponding Requirement</p>	<p>The proposed VSL is worded consistently with the corresponding requirement.</p>



**FERC VSL G4**

Violation Severity Level  
Assignment Should Be Based  
on A Single Violation, Not on  
A Cumulative Number of  
Violations

The proposed VSL is not based on a cumulative number of violations.

**VRF Justifications for FAC-011-4 Requirement R3**

Proposed VRF	Medium
<p><b>FERC VRF G1 Discussion</b> Guideline 1- Consistency with Blackout Report</p>	<p>The VRF is consistent with the conclusions of the final Blackout Report.</p>
<p><b>FERC VRF G2 Discussion</b> Guideline 2- Consistency within a Reliability Standard</p>	<p>This Guideline is no longer applicable since sub-requirements (Parts) utilize the same VRF assigned to the main requirement.</p>
<p><b>FERC VRF G3 Discussion</b> Guideline 3- Consistency among Reliability Standards</p>	<p>A VRF of medium for this requirement is consistent with approved Reliability Standard FAC-008-3, Requirements R2 and R3 which requires development of a methodology to determine certain ratings/limits.</p>
<p><b>FERC VRF G4 Discussion</b> Guideline 4- Consistency with NERC Definitions of VRFs</p>	<p>The establishment of incorrect System Voltage Limits could directly affect the electrical state or the capability of the BES, or the ability to effectively monitor and control the BES. However, violation of this requirement is unlikely, under emergency, abnormal, or restoration conditions anticipated by the preparations, to lead to BES instability, separation, or cascading failures, nor to hinder restoration to a normal condition.</p>
<p><b>FERC VRF G5 Discussion</b> Guideline 5- Treatment of Requirements that Co-mingle More than One Obligation</p>	<p>The requirement contains one objective, therefore, a single VRF is assigned.</p>

**VSLs for FAC-011-4, Requirement R3**

Lower	Moderate	High	Severe
The Reliability Coordinator failed to incorporate one of the Parts of Requirement R3 into its SOL methodology.	The Reliability Coordinator failed to incorporate two of the Parts of Requirement R3 into its SOL methodology.	The Reliability Coordinator failed to incorporate three of the Parts of Requirement R3 into its SOL methodology.	The Reliability Coordinator failed to incorporate four or more of the Parts of Requirement R3 into its SOL methodology.

**VSL Justifications for FAC-011-4, Requirement R3**

<p><b>FERC VSL G1</b>          Violation Severity Level Assignments Should Not Have the Unintended Consequence of Lowering the Current Level of Compliance</p>	<p>The requirement maps to the previously approved Requirement R1 and Requirement R2. Therefore, the proposed VSLs do not have the unintended consequence of lowering compliance.</p>
<p><b>FERC VSL G2</b>          Violation Severity Level Assignments Should Ensure Uniformity and Consistency in the Determination of Penalties   <u>Guideline 2a:</u> The Single Violation Severity Level Assignment Category for "Binary" Requirements Is Not Consistent   <u>Guideline 2b:</u> Violation Severity Level Assignments that Contain Ambiguous Language</p>	<p>The proposed VSLs are not binary and do not use any ambiguous terminology, thereby supporting uniformity and consistency in the determination of similar penalties for similar violations.</p>
<p><b>FERC VSL G3</b>          Violation Severity Level Assignment Should Be Consistent with the Corresponding Requirement</p>	<p>The proposed VSL is worded consistently with the corresponding requirement.</p>

**FERC VSL G4**

Violation Severity Level  
Assignment Should Be Based  
on A Single Violation, Not on  
A Cumulative Number of  
Violations

The proposed VSL is not based on a cumulative number of violations.

**VRF Justifications for FAC-011-4 Requirement R4**

Proposed VRF	Medium
<p><b>FERC VRF G1 Discussion</b> Guideline 1- Consistency with Blackout Report</p>	<p>The VRF is consistent with the conclusions of the final Blackout Report.</p>
<p><b>FERC VRF G2 Discussion</b> Guideline 2- Consistency within a Reliability Standard</p>	<p>This Guideline is no longer applicable since sub-requirements (Parts) utilize the same VRF assigned to the main requirement.</p>
<p><b>FERC VRF G3 Discussion</b> Guideline 3- Consistency among Reliability Standards</p>	<p>A VRF of medium for this requirement is consistent with approved Reliability Standard FAC-008-3, Requirements R2 and R3 which requires development of a methodology to determine certain ratings/limits.</p>
<p><b>FERC VRF G4 Discussion</b> Guideline 4- Consistency with NERC Definitions of VRFs</p>	<p>The establishment of incorrect stability limits could directly affect the electrical state or the capability of the BES, or the ability to effectively monitor and control the BES. However, violation of this requirement is unlikely, under emergency, abnormal, or restoration conditions anticipated by the preparations, to lead to BES instability, separation, or cascading failures, nor to hinder restoration to a normal condition.</p>
<p><b>FERC VRF G5 Discussion</b> Guideline 5- Treatment of Requirements that Co-mingle More than One Obligation</p>	<p>The requirement contains one objective, therefore, a single VRF is assigned.</p>

**VSLs for FAC-011-4, Requirement R4**

Lower	Moderate	High	Severe
The Reliability Coordinator failed to incorporate one of the Parts of Requirement R4 into its SOL methodology.	The Reliability Coordinator failed to incorporate two of the Parts of Requirement R4 into its SOL methodology.	The Reliability Coordinator failed to incorporate three of the Parts of Requirement R4 into its SOL methodology.	The Reliability Coordinator failed to incorporate four or more of the Parts of Requirement R4 into its SOL methodology.

**VSL Justifications for FAC-011-4, Requirement R4**

<p><b>FERC VSL G1</b>          Violation Severity Level Assignments Should Not Have the Unintended Consequence of Lowering the Current Level of Compliance</p>	<p>The requirement maps to the previously approved Requirement R1 and Requirement R2. Therefore, the proposed VSLs do not have the unintended consequence of lowering compliance.</p>
<p><b>FERC VSL G2</b>          Violation Severity Level Assignments Should Ensure Uniformity and Consistency in the Determination of Penalties   <u>Guideline 2a:</u> The Single Violation Severity Level Assignment Category for "Binary" Requirements Is Not Consistent   <u>Guideline 2b:</u> Violation Severity Level Assignments that Contain Ambiguous Language</p>	<p>The proposed VSLs are not binary and do not use any ambiguous terminology, thereby supporting uniformity and consistency in the determination of similar penalties for similar violations.</p>
<p><b>FERC VSL G3</b>          Violation Severity Level Assignment Should Be Consistent with the Corresponding Requirement</p>	<p>The proposed VSL is worded consistently with the corresponding requirement.</p>



**FERC VSL G4**

Violation Severity Level  
Assignment Should Be Based  
on A Single Violation, Not on  
A Cumulative Number of  
Violations

The proposed VSL is not based on a cumulative number of violations.

**VRF Justifications for FAC-011-4 Requirement R5**

Proposed VRF	Medium
<p><b>FERC VRF G1 Discussion</b> Guideline 1- Consistency with Blackout Report</p>	<p>The VRF is consistent with the conclusions of the final Blackout Report.</p>
<p><b>FERC VRF G2 Discussion</b> Guideline 2- Consistency within a Reliability Standard</p>	<p>This Guideline is no longer applicable since sub-requirements (Parts) utilize the same VRF assigned to the main requirement.</p>
<p><b>FERC VRF G3 Discussion</b> Guideline 3- Consistency among Reliability Standards</p>	<p>A VRF of medium for this requirement is consistent with approved Reliability Standard TPL-001-4, Requirement R3, Part 3.4, which requires development of a list of contingencies to be evaluated for System performance.</p>
<p><b>FERC VRF G4 Discussion</b> Guideline 4- Consistency with NERC Definitions of VRFs</p>	<p>Incorrectly identifying the single Contingencies and multiple Contingencies for use in determining stability limits and performing Operational Planning Analyses (OPAs) and Real-time Assessments (RTAs) could directly affect the electrical state or the capability of the BES, or the ability to effectively monitor and control the BES. However, violation of this requirement is unlikely, under emergency, abnormal, or restoration conditions anticipated by the preparations, to lead to BES instability, separation, or cascading failures, nor to hinder restoration to a normal condition.</p>
<p><b>FERC VRF G5 Discussion</b> Guideline 5- Treatment of Requirements that Co-mingle More than One Obligation</p>	<p>The requirement contains one objective, therefore, a single VRF is assigned.</p>

**VSLs for FAC-011-4, Requirement R5**

Lower	Moderate	High	Severe
N/A	The Reliability Coordinator failed to incorporate one of the Parts 5.2, 5.3 of Requirement R5 into its SOL methodology.	The Reliability Coordinator failed to incorporate two of the Parts 5.2, 5.3, of Requirement R5 into its SOL methodology.	The Reliability Coordinator failed to incorporate Part 5.1 of Requirement R5 into its SOL methodology.  OR  The Reliability Coordinator failed to incorporate Parts 5.2, 5.3 of Requirement R5 into its SOL methodology.

**VSL Justifications for FAC-011-4, Requirement R5**

<p><b>FERC VSL G1</b>          Violation Severity Level Assignments Should Not Have the Unintended Consequence of Lowering the Current Level of Compliance</p>	<p>The requirement maps to the previously approved Requirement R3, sub-requirements R3.2, R3.3, and R3.3.1. Therefore, the proposed VSLs do not have the unintended consequence of lowering compliance.</p>
<p><b>FERC VSL G2</b>          Violation Severity Level Assignments Should Ensure Uniformity and Consistency in the Determination of Penalties   <u>Guideline 2a</u>: The Single Violation Severity Level Assignment Category for "Binary" Requirements Is Not Consistent   <u>Guideline 2b</u>: Violation Severity Level Assignments that Contain Ambiguous Language</p>	<p>The proposed VSLs are not binary and do not use any ambiguous terminology, thereby supporting uniformity and consistency in the determination of similar penalties for similar violations.</p>
<p><b>FERC VSL G3</b>          Violation Severity Level Assignment Should Be Consistent with the Corresponding Requirement</p>	<p>The proposed VSL is worded consistently with the corresponding requirement.</p>

**FERC VSL G4**

Violation Severity Level  
Assignment Should Be Based  
on A Single Violation, Not on  
A Cumulative Number of  
Violations

The proposed VSL is not based on a cumulative number of violations.

**VRF Justifications for FAC-011-4 Requirement R6**

Proposed VRF	High
<p><b>FERC VRF G1 Discussion</b>            Guideline 1- Consistency with Blackout Report</p>	<p>The VRF is consistent with the conclusions of the final Blackout Report.</p>
<p><b>FERC VRF G2 Discussion</b>            Guideline 2- Consistency within a Reliability Standard</p>	<p>This Guideline is no longer applicable since sub-requirements (Parts) utilize the same VRF assigned to the main requirement.</p>
<p><b>FERC VRF G3 Discussion</b>            Guideline 3- Consistency among Reliability Standards</p>	<p>A VRF of High for this requirement is consistent with approved Reliability Standard FAC-011-3, Requirement R2 which requires performance criteria within its methodology.</p>
<p><b>FERC VRF G4 Discussion</b>            Guideline 4- Consistency with NERC Definitions of VRFs</p>	<p>Failing to include performance framework could directly cause or contribute to BES instability, separation, or a cascading sequence of failures, or could place the BES at an unacceptable risk of instability, separation, or cascading failures.</p>
<p><b>FERC VRF G5 Discussion</b>            Guideline 5- Treatment of Requirements that Co-mingle More than One Obligation</p>	<p>The requirement contains one objective, therefore, a single VRF is assigned.</p>

**VSLs for FAC-011-4, Requirement R6**

Lower	Moderate	High	Severe
The Reliability Coordinator failed to incorporate one of the Parts of Requirement R6 into its SOL methodology.	The Reliability Coordinator failed to incorporate two of the Parts of Requirement R6 into its SOL methodology.	The Reliability Coordinator failed to incorporate three of the Parts of Requirement R6 into its SOL methodology.	The Reliability Coordinator failed to incorporate four of the Parts of Requirement R6 into its SOL methodology.

**VSL Justifications for FAC-011-4, Requirement R6**

<p><b>FERC VSL G1</b>          Violation Severity Level Assignments Should Not Have the Unintended Consequence of Lowering the Current Level of Compliance</p>	<p>The requirement maps to the previously approved Requirement R2. Therefore, the proposed VSLs do not have the unintended consequence of lowering compliance.</p>
<p><b>FERC VSL G2</b>          Violation Severity Level Assignments Should Ensure Uniformity and Consistency in the Determination of Penalties   <u>Guideline 2a</u>: The Single Violation Severity Level Assignment Category for "Binary" Requirements Is Not Consistent   <u>Guideline 2b</u>: Violation Severity Level Assignments that Contain Ambiguous Language</p>	<p>The proposed VSLs are not binary and do not use any ambiguous terminology, thereby supporting uniformity and consistency in the determination of similar penalties for similar violations.</p>
<p><b>FERC VSL G3</b>          Violation Severity Level Assignment Should Be Consistent with the Corresponding Requirement</p>	<p>The proposed VSL is worded consistently with the corresponding requirement.</p>



**FERC VSL G4**

Violation Severity Level  
Assignment Should Be Based  
on A Single Violation, Not on  
A Cumulative Number of  
Violations

The proposed VSL is not based on a cumulative number of violations.

**VRF Justifications for FAC-011-4 Requirement R7**

Proposed VRF	High
<p><b>FERC VRF G1 Discussion</b> Guideline 1- Consistency with Blackout Report</p>	<p>The VRF is consistent with the conclusions of the final Blackout Report.</p>
<p><b>FERC VRF G2 Discussion</b> Guideline 2- Consistency within a Reliability Standard</p>	<p>This Guideline is no longer applicable since sub-requirements (Parts) utilize the same VRF assigned to the main requirement.</p>
<p><b>FERC VRF G3 Discussion</b> Guideline 3- Consistency among Reliability Standards</p>	<p>A VRF of High for this requirement is consistent with approved Reliability Standard FAC-011-3, Requirement R6 and Requirement R8 which requires performance framework and description of identifying Interconnection Reliability Operating Limits (IROLs) within its methodology.</p>
<p><b>FERC VRF G4 Discussion</b> Guideline 4- Consistency with NERC Definitions of VRFs</p>	<p>Failing to include performance framework could directly cause or contribute to BES instability, separation, or a cascading sequence of failures, or could place the BES at an unacceptable risk of instability, separation, or cascading failures.</p>
<p><b>FERC VRF G5 Discussion</b> Guideline 5- Treatment of Requirements that Co-mingle More than One Obligation</p>	<p>The requirement contains one objective, therefore, a single VRF is assigned.</p>

**VSLs for FAC-011-4, Requirement R7**

Lower	Moderate	High	Severe
N/A	The Reliability Coordinator failed to include a requirement for Part 7.2.	The Reliability Coordinator failed to include a requirement for Part 7.1.	The Reliability Coordinator failed to include in its SOL methodology a risk-based approach for determining how SOL exceedances identified as part of Real-time monitoring and Real-time Assessments must be communicated and if so, with what priority.

**VSL Justifications for FAC-011-4, Requirement R7**

<p><b>FERC VSL G1</b>          Violation Severity Level Assignments Should Not Have the Unintended Consequence of Lowering the Current Level of Compliance</p>	<p>The requirement maps to the previously approved Requirement R2. Therefore, the proposed VSLs do not have the unintended consequence of lowering compliance.</p>
<p><b>FERC VSL G2</b>          Violation Severity Level Assignments Should Ensure Uniformity and Consistency in the Determination of Penalties   <u>Guideline 2a:</u> The Single Violation Severity Level Assignment Category for "Binary" Requirements Is Not Consistent   <u>Guideline 2b:</u> Violation Severity Level Assignments that Contain Ambiguous Language</p>	<p>The proposed VSLs are not binary and do not use any ambiguous terminology, thereby supporting uniformity and consistency in the determination of similar penalties for similar violations.</p>
<p><b>FERC VSL G3</b>          Violation Severity Level Assignment Should Be Consistent with the Corresponding Requirement</p>	<p>The proposed VSL is worded consistently with the corresponding requirement.</p>

**FERC VSL G4**

Violation Severity Level  
Assignment Should Be Based  
on A Single Violation, Not on  
A Cumulative Number of  
Violations

The proposed VSL is not based on a cumulative number of violations.

**VRF Justifications for FAC-011-4 Requirement R8**

Proposed VRF	High
<p><b>FERC VRF G1 Discussion</b> Guideline 1- Consistency with Blackout Report</p>	<p>The VRF is consistent with the conclusions of the final Blackout Report.</p>
<p><b>FERC VRF G2 Discussion</b> Guideline 2- Consistency within a Reliability Standard</p>	<p>This Guideline is no longer applicable since sub-requirements (Parts) utilize the same VRF assigned to the main requirement.</p>
<p><b>FERC VRF G3 Discussion</b> Guideline 3- Consistency among Reliability Standards</p>	<p>A VRF of High for this requirement is consistent with approved Reliability Standard FAC-014-2, Requirements R1, R3, and R4 which requires development of Interconnection Reliability Operating Limits (IROLs) to be consistent with a methodology.</p>
<p><b>FERC VRF G4 Discussion</b> Guideline 4- Consistency with NERC Definitions of VRFs</p>	<p>Failing to correctly identify an IROL could directly cause or contribute to BES instability, separation, or a cascading sequence of failures, or could place the BES at an unacceptable risk of instability, separation, or cascading failures.</p>
<p><b>FERC VRF G5 Discussion</b> Guideline 5- Treatment of Requirements that Co-mingle More than One Obligation</p>	<p>The requirement contains one objective, therefore, a single VRF is assigned.</p>

**VSLs for FAC-011-4, Requirement R8**

Lower	Moderate	High	Severe
N/A	N/A	<p>The Reliability Coordinator failed to include Part 8.1 (a description of how to identify the subset of SOLs that qualify as IROLs) in its SOL methodology.</p> <p>OR</p> <p>The Reliability Coordinator failed to include Part 8.2 (a criteria for determining when violating a SOL qualifies as an IROL) in its SOL methodology.</p> <p>OR</p> <p>The Reliability Coordinator failed to include Part 8.2 (criteria for developing any associated IROL T<sub>v</sub>) in its SOL methodology.</p>	The Reliability Coordinator failed to include Parts 8.1 and 8.2 in its SOL methodology.

**VSL Justifications for FAC-011-4, Requirement R8**

<p><b>FERC VSL G1</b>          Violation Severity Level Assignments Should Not Have the Unintended Consequence of Lowering the Current Level of Compliance</p>	<p>The requirement maps to the previously approved Requirement R1, sub-requirement R1.3 and Requirement R3, sub-requirement R3.5. Therefore, the proposed VSLs do not have the unintended consequence of lowering compliance.</p>
<p><b>FERC VSL G2</b>          Violation Severity Level Assignments Should Ensure Uniformity and Consistency in the Determination of Penalties   <u>Guideline 2a:</u> The Single Violation Severity Level Assignment Category for "Binary" Requirements Is Not Consistent   <u>Guideline 2b:</u> Violation Severity Level Assignments that Contain Ambiguous Language</p>	<p>The proposed VSLs are not binary and do not use any ambiguous terminology, thereby supporting uniformity and consistency in the determination of similar penalties for similar violations.</p>
<p><b>FERC VSL G3</b>          Violation Severity Level Assignment Should Be Consistent with the Corresponding Requirement</p>	<p>The proposed VSL is worded consistently with the corresponding requirement.</p>



**FERC VSL G4**

Violation Severity Level  
Assignment Should Be Based  
on A Single Violation, Not on  
A Cumulative Number of  
Violations

The proposed VSL is not based on a cumulative number of violations.



**VRF Justifications for FAC-011-4 Requirement R9**

Proposed VRF	Lower
<p><b>FERC VRF G1 Discussion</b>            Guideline 1- Consistency with Blackout Report</p>	<p>The VRF is consistent with the conclusions of the final Blackout Report.</p>
<p><b>FERC VRF G2 Discussion</b>            Guideline 2- Consistency within a Reliability Standard</p>	<p>This Guideline is no longer applicable since sub-requirements (Parts) utilize the same VRF assigned to the main requirement.</p>
<p><b>FERC VRF G3 Discussion</b>            Guideline 3- Consistency among Reliability Standards</p>	<p>A VRF of lower for this requirement is consistent with approved Reliability Standard FAC-010-3, Requirement R4, FAC-011-3, Requirement R4, which requires notification of a new or revised methodology to other entities.</p>
<p><b>FERC VRF G4 Discussion</b>            Guideline 4- Consistency with NERC Definitions of VRFs</p>	<p>Failing to provide its SOL methodology to entities within and adjacent to its Reliability Coordinator Area could affect the electrical state or the capability of the BES, or the ability to effectively monitor and control the BES. However, violation of this requirement is unlikely, under emergency, abnormal, or restoration conditions anticipated by the preparations, to lead to BES instability, separation, or cascading failures, nor to hinder restoration to a normal condition.</p>
<p><b>FERC VRF G5 Discussion</b>            Guideline 5- Treatment of Requirements that Co-mingle More than One Obligation</p>	<p>The requirement contains one objective, therefore, a single VRF is assigned.</p>

**VSLs for FAC-011-4, Requirement R9**

Lower	Moderate	High	Severe
<p>The Reliability Coordinator failed to provide its new or revised SOL methodology to one of the parties specified in Requirement R9, Part 9.2 prior to the effective date</p> <p>OR</p> <p>The Reliability Coordinator provided its new or revised SOL methodology to a requesting Reliability Coordinator in accordance with Requirement R9, Part 9.1 but was late by less than or equal to 10 calendar days</p>	<p>The Reliability Coordinator failed to provide its new or revised SOL methodology to two of the parties specified in Requirement R9, Part 9.2 prior to the effective date</p> <p>OR</p> <p>The Reliability Coordinator provided its new or revised SOL methodology to a requesting Reliability Coordinator in accordance with Requirement R9, Part 9.1, but was late by more than 10 calendar days but less than or equal to 20 calendar days.</p>	<p>The Reliability Coordinator failed to provide its new or revised SOL methodology to three of the parties specified in Requirement R9, Part 9.2 prior to the effective date</p> <p>OR</p> <p>The Reliability Coordinator provided its new or revised SOL methodology to a requesting Reliability Coordinator in accordance with Requirement R9, Part 9.1, but was late by more than 20 calendar days but less than or equal to 30 calendar days.</p>	<p>The Reliability Coordinator failed to provide its new or revised SOL methodology to four or more of the parties specified in Requirement R9, Part 9.2 prior to the effective date</p> <p>OR</p> <p>The Reliability Coordinator failed to provide its new or revised SOL methodology to one or more of the parties specified in Requirement R9, Part 9.2</p> <p>OR</p> <p>The Reliability Coordinator provided its new or revised SOL methodology to a requesting Reliability Coordinator in accordance with Requirement R9, Part 9.1, but was late by more than 30 calendar days.</p> <p>OR</p> <p>The Reliability Coordinator failed to provide its new or revised SOL methodology to a requesting Reliability</p>

			Coordinator in accordance with Requirement R9, Part 9.1.
--	--	--	--

**VSL Justifications for FAC-011-4, Requirement R9**

<p><b>FERC VSL G1</b>          Violation Severity Level Assignments Should Not Have the Unintended Consequence of Lowering the Current Level of Compliance</p>	<p>The VSLs map to the currently-effective FAC-011-3 Requirement R4. The proposed VSLs do not lower the level of compliance.</p>
<p><b>FERC VSL G2</b>          Violation Severity Level Assignments Should Ensure Uniformity and Consistency in the Determination of Penalties   <u>Guideline 2a:</u> The Single Violation Severity Level Assignment Category for "Binary" Requirements Is Not Consistent   <u>Guideline 2b:</u> Violation Severity Level Assignments that Contain Ambiguous Language</p>	<p>The proposed VSLs are not binary and do not use any ambiguous terminology, thereby supporting uniformity and consistency in the determination of similar penalties for similar violations.</p>
<p><b>FERC VSL G3</b>          Violation Severity Level Assignment Should Be Consistent with the Corresponding Requirement</p>	<p>The proposed VSL is worded consistently with the corresponding requirement.</p>

**FERC VSL G4**

Violation Severity Level  
Assignment Should Be Based  
on A Single Violation, Not on  
A Cumulative Number of  
Violations

The proposed VSL is not based on a cumulative number of violations.

## Exhibit G-2

Analysis of Violation Risk Factors and Violation Severity Levels  
FAC-014-3



# Violation Risk Factor and Violation Severity Level Justifications

## FAC-014-3 Establish and Communicate System Operating Limits

This document provides the standard drafting team's (SDT's) justification for assignment of violation risk factors (VRFs) and violation severity levels (VSLs) for each requirement in Reliability Standard FAC-014-3 Establish and Communicate System Operating Limits (SOLs). Each requirement is assigned a VRF and a VSL. These elements support the determination of an initial value range for the Base Penalty Amount regarding violations of requirements in FERC-approved Reliability Standards, as defined in the Electric Reliability Organizations Sanction Guidelines. The SDT applied the following NERC criteria and FERC Guidelines when developing the VRFs and VSLs for the requirements.

### **NERC Criteria for Violation Risk Factors**

#### **High Risk Requirement**

A requirement that, if violated, could directly cause or contribute to Bulk Electric System instability, separation, or a cascading sequence of failures, or could place the Bulk Electric System at an unacceptable risk of instability, separation, or cascading failures; or, a requirement in a planning time frame that, if violated, could, under emergency, abnormal, or restorative conditions anticipated by the preparations, directly cause or contribute to Bulk Electric System instability, separation, or a cascading sequence of failures, or could place the Bulk Electric System at an unacceptable risk of instability, separation, or cascading failures, or could hinder restoration to a normal condition.

#### **Medium Risk Requirement**

A requirement that, if violated, could directly affect the electrical state or the capability of the Bulk Electric System, or the ability to effectively monitor and control the Bulk Electric System. However, violation of a medium risk requirement is unlikely to lead to Bulk Electric System instability, separation, or cascading failures; or, a requirement in a planning time frame that, if violated, could, under emergency, abnormal, or restorative conditions anticipated by the preparations, directly and adversely affect the electrical state or capability of the Bulk Electric System, or the ability to effectively monitor, control, or restore the Bulk Electric System. However, violation of a medium risk requirement is unlikely, under emergency, abnormal, or restoration conditions anticipated by the preparations, to lead to Bulk Electric System instability, separation, or cascading failures, nor to hinder restoration to a normal condition.

### **Lower Risk Requirement**

A requirement that is administrative in nature and a requirement that, if violated, would not be expected to adversely affect the electrical state or capability of the Bulk Electric System, or the ability to effectively monitor and control the Bulk Electric System; or, a requirement that is administrative in nature and a requirement in a planning time frame that, if violated, would not, under the emergency, abnormal, or restorative conditions anticipated by the preparations, be expected to adversely affect the electrical state or capability of the Bulk Electric System, or the ability to effectively monitor, control, or restore the Bulk Electric System.

## **FERC Guidelines for Violation Risk Factors**

### **Guideline (1) – Consistency with the Conclusions of the Final Blackout Report**

FERC seeks to ensure that VRFs assigned to Requirements of Reliability Standards in these identified areas appropriately reflect their historical critical impact on the reliability of the Bulk-Power System. In the VSL Order, FERC listed critical areas (from the Final Blackout Report) where violations could severely affect the reliability of the Bulk-Power System:

- Emergency operations
- Vegetation management
- Operator personnel training
- Protection systems and their coordination
- Operating tools and backup facilities
- Reactive power and voltage control
- System modeling and data exchange
- Communication protocol and facilities
- Requirements to determine equipment ratings
- Synchronized data recorders
- Clearer criteria for operationally critical facilities
- Appropriate use of transmission loading relief.

**Guideline (2) – Consistency within a Reliability Standard**

FERC expects a rational connection between the sub-Requirement VRF assignments and the main Requirement VRF assignment.

**Guideline (3) – Consistency among Reliability Standards**

FERC expects the assignment of VRFs corresponding to Requirements that address similar reliability goals in different Reliability Standards would be treated comparably.

**Guideline (4) – Consistency with NERC’s Definition of the Violation Risk Factor Level**

Guideline (4) was developed to evaluate whether the assignment of a particular VRF level conforms to NERC’s definition of that risk level.

**Guideline (5) – Treatment of Requirements that Co-mingle More Than One Obligation**

Where a single Requirement co-mingles a higher risk reliability objective and a lesser risk reliability objective, the VRF assignment for such Requirements must not be watered down to reflect the lower risk level associated with the less important objective of the Reliability Standard.

## NERC Criteria for Violation Severity Levels

VSLs define the degree to which compliance with a requirement was not achieved. Each requirement must have at least one VSL. While it is preferable to have four VSLs for each requirement, some requirements do not have multiple “degrees” of noncompliant performance and may have only one, two, or three VSLs.

VSLs should be based on NERC’s overarching criteria shown in the table below:

Lower VSL	Moderate VSL	High VSL	Severe VSL
The performance or product measured almost meets the full intent of the requirement.	The performance or product measured meets the majority of the intent of the requirement.	The performance or product measured does not meet the majority of the intent of the requirement, but does meet some of the intent.	The performance or product measured does not substantively meet the intent of the requirement.

## FERC Order of Violation Severity Levels

The FERC VSL guidelines are presented below, followed by an analysis of whether the VSLs proposed for each requirement in the standard meet the FERC Guidelines for assessing VSLs:

### Guideline (1) – Violation Severity Level Assignments Should Not Have the Unintended Consequence of Lowering the Current Level of Compliance

Compare the VSLs to any prior levels of non-compliance and avoid significant changes that may encourage a lower level of compliance than was required when levels of non-compliance were used.

### Guideline (2) – Violation Severity Level Assignments Should Ensure Uniformity and Consistency in the Determination of Penalties

A violation of a “binary” type requirement must be a “Severe” VSL.

Do not use ambiguous terms such as “minor” and “significant” to describe noncompliant performance.

### Guideline (3) – Violation Severity Level Assignment Should Be Consistent with the Corresponding Requirement

VSLs should not expand on what is required in the requirement.

**Guideline (4) – Violation Severity Level Assignment Should Be Based on A Single Violation, Not on A Cumulative Number of Violations**

Unless otherwise stated in the requirement, each instance of non-compliance with a requirement is a separate violation. Section 4 of the Sanction Guidelines states that assessing penalties on a per violation per day basis is the “default” for penalty calculations.

<b>VRF Justifications for FAC-014-3 Requirement R1</b>	
<b>Proposed VRF</b>	<b>High</b>
<b>FERC VRF G1 Discussion</b> Guideline 1- Consistency with Blackout Report	The VRF is consistent with the conclusions of the final Blackout Report.
<b>FERC VRF G2 Discussion</b> Guideline 2- Consistency within a Reliability Standard	The requirement has no sub-requirements so a single VRF was assigned.
<b>FERC VRF G3 Discussion</b> Guideline 3- Consistency among Reliability Standards	A VRF of high for this requirement is consistent with approved Reliability Standard TPL-001-4 which requires development of operating conditions through the use of system models.
<b>FERC VRF G4 Discussion</b> Guideline 4- Consistency with NERC Definitions of VRFs	Failing to correctly identify an IROL could directly cause or contribute to Bulk Electric System (BES) instability, separation, or a cascading sequence of failures, or could place the BES at an unacceptable risk of instability, separation, or cascading failures.
<b>FERC VRF G5 Discussion</b> Guideline 5- Treatment of Requirements that Co-mingle More than One Obligation	The requirement contains one objective, therefore a single VRF is assigned.

**VSLs for FAC-014-3, Requirement R1**

Lower	Moderate	High	Severe
N/A	N/A	N/A	The Reliability Coordinator failed to establish Interconnection Reliability Operating Limits (IROLs) for its Reliability Coordinator Area in accordance with its System Operating Limit methodology ("SOL methodology").

**VSL Justifications for FAC-014-3, Requirement R1**

<p><b>FERC VSL G1</b>          Violation Severity Level Assignments Should Not Have the Unintended Consequence of Lowering the Current Level of Compliance</p>	<p>The requirement does not have elements or quantities to evaluate degrees of compliance. The requirement is binary and therefore a VSL of Severe is assigned for non-compliance.</p>
<p><b>FERC VSL G2</b>          Violation Severity Level Assignments Should Ensure Uniformity and Consistency in the Determination of Penalties   <u>Guideline 2a:</u> The Single Violation Severity Level Assignment Category for "Binary" Requirements Is Not Consistent   <u>Guideline 2b:</u> Violation Severity Level Assignments that Contain Ambiguous Language</p>	<p>The requirement does not have elements or quantities to evaluate degrees of compliance. The requirement is binary and therefore a VSL of Severe is assigned for non-compliance.</p> <p>The requirement is clear and does not contain any ambiguous language.</p>
<p><b>FERC VSL G3</b>          Violation Severity Level Assignment Should Be Consistent with the Corresponding Requirement</p>	<p>The proposed VSL is worded consistently with the corresponding requirement.</p>

**FERC VSL G4**

Violation Severity Level  
Assignment Should Be Based  
on A Single Violation, Not on  
A Cumulative Number of  
Violations

The proposed VSL is not based on a cumulative number of violations.



**VRF Justifications for FAC-014-3 Requirement R2**

**Proposed VRF**

**Medium**

This reliability objective of Requirement R2 from approved Reliability Standard FAC-014-2 is now Requirement R2 of proposed Reliability Standard FAC-014-3. Therefore, the existing VRF of medium was maintained for consistency.

**VSLs for FAC-014-3, Requirement R2**

Lower	Moderate	High	Severe
N/A	N/A	N/A	The Transmission Operator failed to establish SOLs for its portion of the Reliability Coordinator Area in accordance with its Reliability Coordinator’s SOL methodology.

**VSL Justifications for FAC-014-3, Requirement R2**

<p><b>FERC VSL G1</b> Violation Severity Level Assignments Should Not Have the Unintended Consequence of Lowering the Current Level of Compliance</p>	<p>The requirement does not have elements or quantities to evaluate degrees of compliance. The requirement is binary and therefore a VSL of Severe is assigned for non-compliance.</p>
<p><b>FERC VSL G2</b> Violation Severity Level Assignments Should Ensure Uniformity and Consistency in the Determination of Penalties  <u>Guideline 2a</u>: The Single Violation Severity Level Assignment Category for "Binary" Requirements Is Not Consistent  <u>Guideline 2b</u>: Violation Severity Level Assignments that Contain Ambiguous Language</p>	<p>The requirement does not have elements or quantities to evaluate degrees of compliance. The requirement is binary and therefore a VSL of Severe is assigned for non-compliance.</p> <p>The requirement is clear and does not contain any ambiguous language.</p>
<p><b>FERC VSL G3</b> Violation Severity Level Assignment Should Be Consistent with the Corresponding Requirement</p>	<p>The proposed VSL is worded consistently with the corresponding requirement.</p>

**FERC VSL G4**

Violation Severity Level  
Assignment Should Be Based  
on A Single Violation, Not on  
A Cumulative Number of  
Violations

The proposed VSL is not based on a cumulative number of violations.

**VRF Justifications for FAC-014-3 Requirement R3**

<b>Proposed VRF</b>	<b>Medium</b>
---------------------	---------------

This reliability objective of Requirement R5, R5.2 from approved Reliability Standard FAC-014-2 is now Requirement R3 of proposed Reliability Standard FAC-014-3. Therefore, the existing VRF of medium was maintained for consistency.

**VSLs for FAC-014-3, Requirement R3**

Lower	Moderate	High	Severe
N/A	N/A	The Transmission Operator provided its SOLs to its Reliability Coordinator, but failed to provide its SOLs at the periodicity at which the Reliability Coordinator needs such information to perform its reliability functions.	The Transmission Operator failed to provide its SOLs to its Reliability Coordinator.

**VSL Justifications for FAC-014-3, Requirement R3**

<p><b>FERC VSL G1</b>          Violation Severity Level Assignments Should Not Have the Unintended Consequence of Lowering the Current Level of Compliance</p>	<p>The requirement maps to the previously approved Requirement R5, R5.2 of FAC-014-2. Therefore, the proposed VSLs do not have the unintended consequence of lowering compliance.</p>
<p><b>FERC VSL G2</b>          Violation Severity Level Assignments Should Ensure Uniformity and Consistency in the Determination of Penalties   <u>Guideline 2a:</u> The Single Violation Severity Level Assignment Category for "Binary" Requirements Is Not Consistent   <u>Guideline 2b:</u> Violation Severity Level Assignments that Contain Ambiguous Language</p>	<p>The proposed VSLs are not binary and do not use any ambiguous terminology, thereby supporting uniformity and consistency in the determination of similar penalties for similar violations.</p>
<p><b>FERC VSL G3</b>          Violation Severity Level Assignment Should Be Consistent with the Corresponding Requirement</p>	<p>The proposed VSL is worded consistently with the corresponding requirement.</p>

**FERC VSL G4**

Violation Severity Level  
Assignment Should Be Based  
on A Single Violation, Not on  
A Cumulative Number of  
Violations

The proposed VSL is not based on a cumulative number of violations.



**VRF Justifications for FAC-014-3 Requirement R4**

Proposed VRF	High
<p><b>FERC VRF G1 Discussion</b> Guideline 1- Consistency with Blackout Report</p>	<p>The VRF is consistent with the conclusions of the final Blackout Report.</p>
<p><b>FERC VRF G2 Discussion</b> Guideline 2- Consistency within a Reliability Standard</p>	<p>The requirement has no sub-requirements so a single VRF was assigned.</p>
<p><b>FERC VRF G3 Discussion</b> Guideline 3- Consistency among Reliability Standards</p>	<p>A VRF of high for this requirement is consistent with approved Reliability Standard TPL-001-4 which requires development of operating conditions through the use of system models.</p>
<p><b>FERC VRF G4 Discussion</b> Guideline 4- Consistency with NERC Definitions of VRFs</p>	<p>The establishment of incorrect stability limits could directly cause or contribute to BES instability, separation, or a cascading sequence of failures, or could place the BES at an unacceptable risk of instability, separation, or cascading failures.</p>
<p><b>FERC VRF G5 Discussion</b> Guideline 5- Treatment of Requirements that Co-mingle More than One Obligation</p>	<p>The requirement contains one objective, therefore, a single VRF is assigned.</p>

**VSLs for FAC-014-3, Requirement R4**

Lower	Moderate	High	Severe
N/A	N/A	N/A	The Reliability Coordinator failed to determine stability limits to be used in operations when the limit impacts more than one Transmission Operator in its Reliability Coordinator Area in accordance with its SOL methodology.

**VSL Justifications for FAC-014-3, Requirement R4**

<p><b>FERC VSL G1</b> Violation Severity Level Assignments Should Not Have the Unintended Consequence of Lowering the Current Level of Compliance</p>	<p>The requirement does not have elements or quantities to evaluate degrees of compliance. The requirement is binary, and therefore, a VSL of Severe is assigned for non-compliance.</p>
<p><b>FERC VSL G2</b> Violation Severity Level Assignments Should Ensure Uniformity and Consistency in the Determination of Penalties  <u>Guideline 2a</u>: The Single Violation Severity Level Assignment Category for "Binary" Requirements Is Not Consistent  <u>Guideline 2b</u>: Violation Severity Level Assignments that Contain Ambiguous Language</p>	<p>The requirement does not have elements or quantities to evaluate degrees of compliance. The requirement is binary, and therefore, a VSL of Severe is assigned for non-compliance.</p> <p>The requirement is clear and does not contain any ambiguous language.</p>
<p><b>FERC VSL G3</b> Violation Severity Level Assignment Should Be Consistent with the Corresponding Requirement</p>	<p>The proposed VSL is worded consistently with the corresponding requirement.</p>

**FERC VSL G4**

Violation Severity Level  
Assignment Should Be Based  
on A Single Violation, Not on  
A Cumulative Number of  
Violations

The proposed VSL is not based on a cumulative number of violations.

**VRF Justifications for FAC-014-3 Requirement R5**

Proposed VRF	High
--------------	------

This reliability objective of Requirement R5 and Requirement R5, R5.1 from approved Reliability Standard FAC-014-2 is now Requirement R5 of proposed Reliability Standard FAC-014-3. Therefore, the existing VRF of high was maintained for consistency.

**VSLs for FAC-014-3, Requirement R5**

Lower	Moderate	High	Severe
The Reliability Coordinator did not provide one of the items listed in Requirement R5 Parts 5.1 through 5.6.	The Reliability Coordinator did not provide two of the items listed in Requirement R5 Parts 5.1 through 5.6.	The Reliability Coordinator did not provide three of the items listed in Requirement R5 Parts 5.1 through 5.6.	The Reliability Coordinator did not provide four or more of the items listed in Parts 5.1 through 5.6.

**VSL Justifications for FAC-014-3, Requirement R5**

<p><b>FERC VSL G1</b>          Violation Severity Level Assignments Should Not Have the Unintended Consequence of Lowering the Current Level of Compliance</p>	<p>The requirement maps to the previously approved Requirement R5, sub-requirement R5.1. Therefore, the proposed VSLs do not have the unintended consequence of lowering compliance.</p>
<p><b>FERC VSL G2</b>          Violation Severity Level Assignments Should Ensure Uniformity and Consistency in the Determination of Penalties   <u>Guideline 2a:</u> The Single Violation Severity Level Assignment Category for "Binary" Requirements Is Not Consistent   <u>Guideline 2b:</u> Violation Severity Level Assignments that Contain Ambiguous Language</p>	<p>The proposed VSLs are not binary and do not use any ambiguous terminology, thereby supporting uniformity and consistency in the determination of similar penalties for similar violations.</p>
<p><b>FERC VSL G3</b>          Violation Severity Level Assignment Should Be Consistent with the Corresponding Requirement</p>	<p>The proposed VSL is worded consistently with the corresponding requirement.</p>

**FERC VSL G4**

Violation Severity Level  
Assignment Should Be Based  
on A Single Violation, Not on  
A Cumulative Number of  
Violations

The proposed VSL is not based on a cumulative number of violations.



**VRF Justifications for FAC-014-3 Requirement R6**

<b>Proposed VRF</b>	<b>Medium</b>
<p>The reliability objective of Requirement R3 from approved Reliability Standard FAC-014-2 is now Requirement R6 of the proposed standard. Therefore, the existing VRF of medium was maintained for consistency.</p>	

**VSLs for FAC-014-3, Requirement R6**

Lower	Moderate	High	Severe
N/A	N/A	<p>The Planning Coordinator or a Transmission Planner used less limiting Facility Ratings, System steady state voltage limits or stability criteria than the criteria for Facility Ratings, System Voltage Limits or stability described in its respective Reliability Coordinator’s SOL methodology, but failed to provide a technical rationale for allowing the use of less limiting Facility Ratings, System Voltage Limits or stability criteria.</p>	<p>The Planning Coordinator or a Transmission Planner failed to implement a process to ensure that Facility Ratings, System steady state voltage limits or stability criteria used in Planning Assessment are equally limiting or more limiting than the criteria for Facility Ratings, System Voltage Limits or stability described in its respective Reliability Coordinator’s SOL methodology.</p>

**VSL Justifications for FAC-014-3, Requirement R6**

<p><b>FERC VSL G1</b>          Violation Severity Level Assignments Should Not Have the Unintended Consequence of Lowering the Current Level of Compliance</p>	<p>The requirement maps to the previously approved Requirement R3 of FAC-014-2. Therefore, the proposed VSLs do not have the unintended consequence of lowering compliance</p>
<p><b>FERC VSL G2</b>          Violation Severity Level Assignments Should Ensure Uniformity and Consistency in the Determination of Penalties   <u>Guideline 2a:</u> The Single Violation Severity Level Assignment Category for "Binary" Requirements Is Not Consistent   <u>Guideline 2b:</u> Violation Severity Level Assignments that Contain Ambiguous Language</p>	<p>The proposed VSLs are not binary and do not use any ambiguous terminology, thereby supporting uniformity and consistency in the determination of similar penalties for similar violations.</p>
<p><b>FERC VSL G3</b>          Violation Severity Level Assignment Should Be Consistent with the Corresponding Requirement</p>	<p>The proposed VSL is worded consistently with the corresponding requirement.</p>

**FERC VSL G4**

Violation Severity Level  
Assignment Should Be Based  
on A Single Violation, Not on  
A Cumulative Number of  
Violations

The proposed VSL is not based on a cumulative number of violations.

**VRF Justifications for FAC-014-3 Requirement R7**

**Proposed VRF**

**Medium**

The reliability objective of Requirement R5 from approved Reliability Standard FAC-014-2 is now Requirement R7 of the proposed standard. Therefore, the existing VRF of medium was maintained for consistency.

**VSLs for FAC-014-3, Requirement R7**

Lower	Moderate	High	Severe
<p>The Planning Coordinator or a Transmission Planner communicated the identified instability to each impacted Reliability Coordinator and Transmission Operator, but the communication did not contain one of the elements listed in Requirement R7, Parts 7.1 through 7.5.</p>	<p>The Planning Coordinator or a Transmission Planner communicated the identified instability to each impacted Reliability Coordinator and Transmission Operator, but the communication did not contain two of the elements listed in Requirement R7, Parts 7.1 through 7.5.</p>	<p>The Planning Coordinator or a Transmission Planner communicated the identified instability to each impacted Reliability Coordinator and Transmission Operator, but the communication did not contain three elements listed in Requirement R7, Parts 7.1 through 7.5.</p>	<p>The Planning Coordinator or a Transmission Planner communicated the identified instability to each impacted Reliability Coordinator and Transmission Operator, but the communication did not contain four or more of the elements listed in Requirement R7, Parts 7.1 through 7.5.</p> <p>OR</p> <p>The Planning Coordinator or a Transmission Planner failed to communicate any identified instability, to each impacted Reliability Coordinator and Transmission Operator.</p>

**VSL Justifications for FAC-014-3, Requirement R7**

<p><b>FERC VSL G1</b>          Violation Severity Level Assignments Should Not Have the Unintended Consequence of Lowering the Current Level of Compliance</p>	<p>The requirement maps to the previously approved Requirement R5, sub-requirement R5.3 and 5.4 of FAC-014-2. Therefore, the proposed VSLs do not have the unintended consequence of lowering compliance.</p>
<p><b>FERC VSL G2</b>          Violation Severity Level Assignments Should Ensure Uniformity and Consistency in the Determination of Penalties   <u>Guideline 2a:</u> The Single Violation Severity Level Assignment Category for "Binary" Requirements Is Not Consistent   <u>Guideline 2b:</u> Violation Severity Level Assignments that Contain Ambiguous Language</p>	<p>The proposed VSLs are not binary and do not use any ambiguous terminology, thereby supporting uniformity and consistency in the determination of similar penalties for similar violations.</p>
<p><b>FERC VSL G3</b>          Violation Severity Level Assignment Should Be Consistent with the Corresponding Requirement</p>	<p>The proposed VSL is worded consistently with the corresponding requirement.</p>

**VSL Justifications for FAC-014-3, Requirement R7**

**FERC VSL G4**

Violation Severity Level  
Assignment Should Be Based  
on A Single Violation, Not on  
A Cumulative Number of  
Violations

The proposed VSL is not based on a cumulative number of violations.

**VRF Justifications for FAC-014-1 Requirement R8**

Proposed VRF

Medium

This reliability objective of Requirement R5, R5.3 and Requirement R6 from approved Reliability Standard FAC-014-2 is now Requirement R8 of the proposed standard. Therefore, the existing VRF of medium was maintained for consistency.



**VSL Justifications for FAC-014-3, Requirement R8**

<p><b>FERC VSL G1</b>          Violation Severity Level Assignments Should Not Have the Unintended Consequence of Lowering the Current Level of Compliance</p>	<p>The requirement maps to the previously approved Requirement R5, sub-requirement R5.3 and 5.4 of FAC-014-2. Therefore, the proposed VSLs do not have the unintended consequence of lowering compliance.</p>
<p><b>FERC VSL G2</b>          Violation Severity Level Assignments Should Ensure Uniformity and Consistency in the Determination of Penalties   <u>Guideline 2a:</u> The Single Violation Severity Level Assignment Category for "Binary" Requirements Is Not Consistent   <u>Guideline 2b:</u> Violation Severity Level Assignments that Contain Ambiguous Language</p>	<p>The proposed VSLs are not binary and do not use any ambiguous terminology, thereby supporting uniformity and consistency in the determination of similar penalties for similar violations.</p>
<p><b>FERC VSL G3</b>          Violation Severity Level Assignment Should Be Consistent with the Corresponding Requirement</p>	<p>The proposed VSL is worded consistently with the corresponding requirement.</p>

**VSL Justifications for FAC-014-3, Requirement R8**

**FERC VSL G4**

Violation Severity Level  
Assignment Should Be Based  
on A Single Violation, Not on  
A Cumulative Number of  
Violations

The proposed VSL is not based on a cumulative number of violations.

## Exhibit G-3

Analysis of Violation Risk Factors and Violation Severity Levels  
IRO-008-3

# Violation Risk Factor and Violation Severity Level Justifications

## Project 2015-09 Establish and Communicate System Operating Limits

This document provides the standard drafting team's (SDT's) justification for assignment of violation risk factors (VRFs) and violation severity levels (VSLs) for each requirement in IRO-008. Each requirement is assigned a VRF and a VSL. These elements support the determination of an initial value range for the Base Penalty Amount regarding violations of requirements in FERC-approved Reliability Standards, as defined in the Electric Reliability Organizations (ERO) Sanction Guidelines. The SDT applied the following NERC criteria and FERC Guidelines when developing the VRFs and VSLs for the requirements.

### **NERC Criteria for Violation Risk Factors**

#### **High Risk Requirement**

A requirement that, if violated, could directly cause or contribute to Bulk Electric System instability, separation, or a cascading sequence of failures, or could place the Bulk Electric System at an unacceptable risk of instability, separation, or cascading failures; or, a requirement in a planning time frame that, if violated, could, under emergency, abnormal, or restorative conditions anticipated by the preparations, directly cause or contribute to Bulk Electric System instability, separation, or a cascading sequence of failures, or could place the Bulk Electric System at an unacceptable risk of instability, separation, or cascading failures, or could hinder restoration to a normal condition.

#### **Medium Risk Requirement**

A requirement that, if violated, could directly affect the electrical state or the capability of the Bulk Electric System, or the ability to effectively monitor and control the Bulk Electric System. However, violation of a medium risk requirement is unlikely to lead to Bulk Electric System instability, separation, or cascading failures; or, a requirement in a planning time frame that, if violated, could, under emergency, abnormal, or restorative conditions anticipated by the preparations, directly and adversely affect the electrical state or capability of the Bulk Electric System, or the ability to effectively monitor, control, or restore the Bulk Electric System. However, violation of a medium risk requirement is unlikely, under emergency, abnormal, or restoration conditions anticipated by the preparations, to lead to Bulk Electric System instability, separation, or cascading failures, nor to hinder restoration to a normal condition.

## **Lower Risk Requirement**

A requirement that is administrative in nature and a requirement that, if violated, would not be expected to adversely affect the electrical state or capability of the Bulk Electric System, or the ability to effectively monitor and control the Bulk Electric System; or, a requirement that is administrative in nature and a requirement in a planning time frame that, if violated, would not, under the emergency, abnormal, or restorative conditions anticipated by the preparations, be expected to adversely affect the electrical state or capability of the Bulk Electric System, or the ability to effectively monitor, control, or restore the Bulk Electric System.

## **FERC Guidelines for Violation Risk Factors**

### **Guideline (1) – Consistency with the Conclusions of the Final Blackout Report**

FERC seeks to ensure that VRFs assigned to Requirements of Reliability Standards in these identified areas appropriately reflect their historical critical impact on the reliability of the Bulk-Power System. In the VSL Order, FERC listed critical areas (from the Final Blackout Report) where violations could severely affect the reliability of the Bulk-Power System:

- Emergency operations
- Vegetation management
- Operator personnel training
- Protection systems and their coordination
- Operating tools and backup facilities
- Reactive power and voltage control
- System modeling and data exchange
- Communication protocol and facilities
- Requirements to determine equipment ratings
- Synchronized data recorders
- Clearer criteria for operationally critical facilities
- Appropriate use of transmission loading relief.

**Guideline (2) – Consistency within a Reliability Standard**

FERC expects a rational connection between the sub-Requirement VRF assignments and the main Requirement VRF assignment.

**Guideline (3) – Consistency among Reliability Standards**

FERC expects the assignment of VRFs corresponding to Requirements that address similar reliability goals in different Reliability Standards would be treated comparably.

**Guideline (4) – Consistency with NERC’s Definition of the Violation Risk Factor Level**

Guideline (4) was developed to evaluate whether the assignment of a particular VRF level conforms to NERC’s definition of that risk level.

**Guideline (5) – Treatment of Requirements that Co-mingle More Than One Obligation**

Where a single Requirement co-mingles a higher risk reliability objective and a lesser risk reliability objective, the VRF assignment for such Requirements must not be watered down to reflect the lower risk level associated with the less important objective of the Reliability Standard.

## NERC Criteria for Violation Severity Levels

VSLs define the degree to which compliance with a requirement was not achieved. Each requirement must have at least one VSL. While it is preferable to have four VSLs for each requirement, some requirements do not have multiple “degrees” of noncompliant performance and may have only one, two, or three VSLs.

VSLs should be based on NERC’s overarching criteria shown in the table below:

Lower VSL	Moderate VSL	High VSL	Severe VSL
The performance or product measured almost meets the full intent of the requirement.	The performance or product measured meets the majority of the intent of the requirement.	The performance or product measured does not meet the majority of the intent of the requirement, but does meet some of the intent.	The performance or product measured does not substantively meet the intent of the requirement.

## FERC Order of Violation Severity Levels

The FERC VSL guidelines are presented below, followed by an analysis of whether the VSLs proposed for each requirement in the standard meet the FERC Guidelines for assessing VSLs:

### Guideline (1) – Violation Severity Level Assignments Should Not Have the Unintended Consequence of Lowering the Current Level of Compliance

Compare the VSLs to any prior levels of non-compliance and avoid significant changes that may encourage a lower level of compliance than was required when levels of non-compliance were used.

### Guideline (2) – Violation Severity Level Assignments Should Ensure Uniformity and Consistency in the Determination of Penalties

A violation of a “binary” type requirement must be a “Severe” VSL.

Do not use ambiguous terms such as “minor” and “significant” to describe noncompliant performance.

### Guideline (3) – Violation Severity Level Assignment Should Be Consistent with the Corresponding Requirement

VSLs should not expand on what is required in the requirement.

**Guideline (4) – Violation Severity Level Assignment Should Be Based on a Single Violation, Not on a Cumulative Number of Violations**

Unless otherwise stated in the requirement, each instance of non-compliance with a requirement is a separate violation. Section 4 of the Sanction Guidelines states that assessing penalties on a per violation per day basis is the “default” for penalty calculations.

**VRF Justification for IRO-008-3, Requirement R1**

The VRF did not change from the previously FERC approved IRO-008-2 Reliability Standard.

**VSL Justification for IRO-008-3, Requirement R1**

The VSL did not change from the previously FERC approved IRO-008-2 Reliability Standard.

**VRF Justification for IRO-008-3, Requirement R2**

The VRF did not change from the previously FERC approved IRO-008-2 Reliability Standard.

**VSL Justification for IRO-008-3, Requirement R2**

The VSL did not change from the previously FERC approved IRO-008-2 Reliability Standard.

**VRF Justification for IRO-008-3, Requirement R3**

The VRF did not change from the previously FERC approved IRO-008-2 Reliability Standard.

**VSL Justification for IRO-008-3, Requirement R3**

The VSL did not change from the previously FERC approved IRO-008-2 Reliability Standard.

**VRF Justification for IRO-008-3, Requirement R4**

The VRF did not change from the previously FERC approved IRO-008-2 Reliability Standard.

**VSL Justification for IRO-008-3, Requirement R4**

The VSL did not change from the previously FERC approved IRO-008-2 Reliability Standard.

**VRF Justification for IRO-008-3, Requirement R5**

The VRF did not change from the previously FERC approved IRO-008-2 Reliability Standard.

**VSL Justification for IRO-008-3, Requirement R5**

The VSL did not change from the previously FERC approved IRO-008-2 Reliability Standard.



**VRF Justification for IRO-008-3, Requirement R6**

The VRF did not change from the previously FERC approved IRO-008-2 Reliability Standard.

**VSL Justification for IRO-008-3, Requirement R6**

The VSL did not change from the previously FERC approved IRO-008-2 Reliability Standard.

<b>VRF Justifications for IRO-008-3 R7</b>	
<b>Proposed VRF</b>	<b>Medium</b>
NERC VRF Discussion	
<b>FERC VRF G1 Discussion</b> Guideline 1- Consistency with Blackout Report	The VRF is consistent with the conclusions of the final Blackout Report.
<b>FERC VRF G2 Discussion</b> Guideline 2- Consistency within a Reliability Standard	The requirement has no sub-requirements so a single VRF was assigned.
<b>FERC VRF G3 Discussion</b> Guideline 3- Consistency among Reliability Standards	A VRF of medium for this requirement is consistent with approved Reliability Standard FAC-014-2, Requirement R2.
<b>FERC VRF G4 Discussion</b> Guideline 4- Consistency with NERC Definitions of VRFs	Not having a methodology for determining SOL exceedances has the potential unintended consequence of creating inconsistencies in determining SOL exceedances which could directly affect the electrical state or the capability of the Bulk Electric System (BES), or the ability to effectively monitor and control the BES. However, violation of this requirement is unlikely, under emergency, abnormal, or restoration conditions anticipated by the preparations, to lead to BES instability, separation, or cascading failures, nor to hinder restoration to a normal condition.
<b>FERC VRF G5 Discussion</b>	The requirement contains one objective, therefore, a single VRF is assigned.

**VRF Justifications for IRO-008-3 R7**

<b>Proposed VRF</b>	<b>Medium</b>
Guideline 5- Treatment of Requirements that Co-mingle More than One Obligation	

**VSLs for IRO-008-3, R7**

<b>Lower</b>	<b>Moderate</b>	<b>High</b>	<b>Severe</b>
			The Reliability Coordinator failed to use its SOL methodology when determining SOL exceedances for Real-time Assessments, Real-time monitoring, and Operational Planning Analysis.

## Exhibit G-4

Analysis of Violation Risk Factors and Violation Severity Levels  
TOP-001-6

# Violation Risk Factor and Violation Severity Level Justifications

## Project 2015-09 Establish and Communicate System Operating Limits

This document provides the standard drafting team's (SDT's) justification for assignment of violation risk factors (VRFs) and violation severity levels (VSLs) for each requirement in TOP-001. Each requirement is assigned a VRF and a VSL. These elements support the determination of an initial value range for the Base Penalty Amount regarding violations of requirements in FERC-approved Reliability Standards, as defined in the Electric Reliability Organizations (ERO) Sanction Guidelines. The SDT applied the following NERC criteria and FERC Guidelines when developing the VRFs and VSLs for the requirements.

### **NERC Criteria for Violation Risk Factors**

#### **High Risk Requirement**

A requirement that, if violated, could directly cause or contribute to Bulk Electric System instability, separation, or a cascading sequence of failures, or could place the Bulk Electric System at an unacceptable risk of instability, separation, or cascading failures; or, a requirement in a planning time frame that, if violated, could, under emergency, abnormal, or restorative conditions anticipated by the preparations, directly cause or contribute to Bulk Electric System instability, separation, or a cascading sequence of failures, or could place the Bulk Electric System at an unacceptable risk of instability, separation, or cascading failures, or could hinder restoration to a normal condition.

#### **Medium Risk Requirement**

A requirement that, if violated, could directly affect the electrical state or the capability of the Bulk Electric System, or the ability to effectively monitor and control the Bulk Electric System. However, violation of a medium risk requirement is unlikely to lead to Bulk Electric System instability, separation, or cascading failures; or, a requirement in a planning time frame that, if violated, could, under emergency, abnormal, or restorative conditions anticipated by the preparations, directly and adversely affect the electrical state or capability of the Bulk Electric System, or the ability to effectively monitor, control, or restore the Bulk Electric System. However, violation of a medium risk requirement is unlikely, under emergency, abnormal, or restoration conditions anticipated by the preparations, to lead to Bulk Electric System instability, separation, or cascading failures, nor to hinder restoration to a normal condition.

## **Lower Risk Requirement**

A requirement that is administrative in nature and a requirement that, if violated, would not be expected to adversely affect the electrical state or capability of the Bulk Electric System, or the ability to effectively monitor and control the Bulk Electric System; or, a requirement that is administrative in nature and a requirement in a planning time frame that, if violated, would not, under the emergency, abnormal, or restorative conditions anticipated by the preparations, be expected to adversely affect the electrical state or capability of the Bulk Electric System, or the ability to effectively monitor, control, or restore the Bulk Electric System.

## **FERC Guidelines for Violation Risk Factors**

### **Guideline (1) – Consistency with the Conclusions of the Final Blackout Report**

FERC seeks to ensure that VRFs assigned to Requirements of Reliability Standards in these identified areas appropriately reflect their historical critical impact on the reliability of the Bulk-Power System. In the VSL Order, FERC listed critical areas (from the Final Blackout Report) where violations could severely affect the reliability of the Bulk-Power System:

- Emergency operations
- Vegetation management
- Operator personnel training
- Protection systems and their coordination
- Operating tools and backup facilities
- Reactive power and voltage control
- System modeling and data exchange
- Communication protocol and facilities
- Requirements to determine equipment ratings
- Synchronized data recorders
- Clearer criteria for operationally critical facilities
- Appropriate use of transmission loading relief.

**Guideline (2) – Consistency within a Reliability Standard**

FERC expects a rational connection between the sub-Requirement VRF assignments and the main Requirement VRF assignment.

**Guideline (3) – Consistency among Reliability Standards**

FERC expects the assignment of VRFs corresponding to Requirements that address similar reliability goals in different Reliability Standards would be treated comparably.

**Guideline (4) – Consistency with NERC’s Definition of the Violation Risk Factor Level**

Guideline (4) was developed to evaluate whether the assignment of a particular VRF level conforms to NERC’s definition of that risk level.

**Guideline (5) – Treatment of Requirements that Co-mingle More Than One Obligation**

Where a single Requirement co-mingles a higher risk reliability objective and a lesser risk reliability objective, the VRF assignment for such Requirements must not be watered down to reflect the lower risk level associated with the less important objective of the Reliability Standard.

## NERC Criteria for Violation Severity Levels

VSLs define the degree to which compliance with a requirement was not achieved. Each requirement must have at least one VSL. While it is preferable to have four VSLs for each requirement, some requirements do not have multiple “degrees” of noncompliant performance and may have only one, two, or three VSLs.

VSLs should be based on NERC’s overarching criteria shown in the table below:

Lower VSL	Moderate VSL	High VSL	Severe VSL
The performance or product measured almost meets the full intent of the requirement.	The performance or product measured meets the majority of the intent of the requirement.	The performance or product measured does not meet the majority of the intent of the requirement, but does meet some of the intent.	The performance or product measured does not substantively meet the intent of the requirement.

## FERC Order of Violation Severity Levels

The FERC VSL guidelines are presented below, followed by an analysis of whether the VSLs proposed for each requirement in the standard meet the FERC Guidelines for assessing VSLs:

### Guideline (1) – Violation Severity Level Assignments Should Not Have the Unintended Consequence of Lowering the Current Level of Compliance

Compare the VSLs to any prior levels of non-compliance and avoid significant changes that may encourage a lower level of compliance than was required when levels of non-compliance were used.

### Guideline (2) – Violation Severity Level Assignments Should Ensure Uniformity and Consistency in the Determination of Penalties

A violation of a “binary” type requirement must be a “Severe” VSL.

Do not use ambiguous terms such as “minor” and “significant” to describe noncompliant performance.

### Guideline (3) – Violation Severity Level Assignment Should Be Consistent with the Corresponding Requirement

VSLs should not expand on what is required in the requirement.

**Guideline (4) – Violation Severity Level Assignment Should Be Based on a Single Violation, Not on a Cumulative Number of Violations**

Unless otherwise stated in the requirement, each instance of non-compliance with a requirement is a separate violation. Section 4 of the Sanction Guidelines states that assessing penalties on a per violation per day basis is the “default” for penalty calculations.

**VRF Justification for TOP-001-6, Requirement R1**

The VRF did not change from the previously FERC approved TOP-001-5 Reliability Standard.

**VSL Justification for TOP-001-6, Requirement R1**

The VSL did not change from the previously FERC approved TOP-001-5 Reliability Standard.

**VRF Justification for TOP-001-6, Requirement R2**

The VRF did not change from the previously FERC approved TOP-001-5 Reliability Standard.

**VSL Justification for TOP-001-6, Requirement R2**

The VSL did not change from the previously FERC approved TOP-001-5 Reliability Standard.

**VRF Justification for TOP-001-6, Requirement R3**

The VRF did not change from the previously FERC approved TOP-001-5 Reliability Standard.

**VSL Justification for TOP-001-6, Requirement R3**

The VSL did not change from the previously FERC approved TOP-001-5 Reliability Standard.

**VRF Justification for TOP-001-6, Requirement R4**

The VRF did not change from the previously FERC approved TOP-001-5 Reliability Standard.

**VSL Justification for TOP-001-6, Requirement R4**

The VSL did not change from the previously FERC approved TOP-001-5 Reliability Standard.

**VRF Justification for TOP-001-6, Requirement R5**

The VRF did not change from the previously FERC approved TOP-001-5 Reliability Standard.

**VSL Justification for TOP-001-6, Requirement R5**

The VSL did not change from the previously FERC approved TOP-001-5 Reliability Standard.



**VRF Justification for TOP-001-6, Requirement R6**

The VRF did not change from the previously FERC approved TOP-001-5 Reliability Standard.

**VSL Justification for TOP-001-6, Requirement R6**

The VSL did not change from the previously FERC approved TOP-001-5 Reliability Standard.

**VRF Justification for TOP-001-6, Requirement R7**

The VRF did not change from the previously FERC approved TOP-001-5 Reliability Standard.

**VSL Justification for TOP-001-6, Requirement R7**

The VSL did not change from the previously FERC approved TOP-001-5 Reliability Standard.

**VRF Justification for TOP-001-6, Requirement R8**

The VRF did not change from the previously FERC approved TOP-001-5 Reliability Standard.

**VSL Justification for TOP-001-6, Requirement R8**

The VSL did not change from the previously FERC approved TOP-001-5 Reliability Standard.

**VRF Justification for TOP-001-6, Requirement R9**

The VRF did not change from the previously FERC approved TOP-001-5 Reliability Standard.

**VSL Justification for TOP-001-6, Requirement R9**

The VSL did not change from the previously FERC approved TOP-001-5 Reliability Standard.

**VRF Justification for TOP-001-6, Requirement R10**

The VRF did not change from the previously FERC approved TOP-001-5 Reliability Standard.

**VSL Justification for TOP-001-6, Requirement R10**

The VSL did not change from the previously FERC approved TOP-001-5 Reliability Standard.

**VRF Justification for TOP-001-6, Requirement R11**

The VRF did not change from the previously FERC approved TOP-001-5 Reliability Standard.

**VSL Justification for TOP-001-6, Requirement R11**

The VSL did not change from the previously FERC approved TOP-001-5 Reliability Standard.

**VRF Justification for TOP-001-6, Requirement R12**

The VRF did not change from the previously FERC approved TOP-001-5 Reliability Standard.

**VSL Justification for TOP-001-6, Requirement R12**

The VSL did not change from the previously FERC approved TOP-001-5 Reliability Standard.

**VRF Justification for TOP-001-6, Requirement R13**

The VRF did not change from the previously FERC approved TOP-001-5 Reliability Standard.

**VSL Justification for TOP-001-6, Requirement R13**

The VSL did not change from the previously FERC approved TOP-001-5 Reliability Standard.

**VRF Justification for TOP-001-6, Requirement R14**

The VRF did not change from the previously FERC approved TOP-001-5 Reliability Standard.

**VSL Justification for TOP-001-6, Requirement R14**

The VSL did not change from the previously FERC approved TOP-001-5 Reliability Standard.

**VRF Justification for TOP-001-6, Requirement R15**

The VRF did not change from the previously FERC approved TOP-001-5 Reliability Standard.

**VSL Justification for TOP-001-6, Requirement R15**

The VSL did not change from the previously FERC approved TOP-001-5 Reliability Standard.

**VRF Justification for TOP-001-6, Requirement R16**

The VRF did not change from the previously FERC approved TOP-001-5 Reliability Standard.

**VSL Justification for TOP-001-6, Requirement R16**

The VSL did not change from the previously FERC approved TOP-001-5 Reliability Standard.

**VRF Justification for TOP-001-6, Requirement R17**

The VRF did not change from the previously FERC approved TOP-001-5 Reliability Standard.

**VSL Justification for TOP-001-6, Requirement R17**

The VSL did not change from the previously FERC approved TOP-001-5 Reliability Standard.

**VRF Justification for TOP-001-6, Requirement R18**

The VRF did not change from the previously FERC approved TOP-001-5 Reliability Standard.

**VSL Justification for TOP-001-6, Requirement R18**

The VSL did not change from the previously FERC approved TOP-001-5 Reliability Standard.

**VRF Justification for TOP-001-6, Requirement R19**

The VRF did not change from the previously FERC approved TOP-001-5 Reliability Standard.

**VSL Justification for TOP-001-6, Requirement R19**

The VSL did not change from the previously FERC approved TOP-001-5 Reliability Standard.

**VRF Justification for TOP-001-6, Requirement R20**

The VRF did not change from the previously FERC approved TOP-001-5 Reliability Standard.

**VSL Justification for TOP-001-6, Requirement R20**

The VSL did not change from the previously FERC approved TOP-001-5 Reliability Standard.

**VRF Justification for TOP-001-6, Requirement R21**

The VRF did not change from the previously FERC approved TOP-001-5 Reliability Standard.

**VSL Justification for TOP-001-6, Requirement R21**

The VSL did not change from the previously FERC approved TOP-001-5 Reliability Standard.

**VRF Justification for TOP-001-6, Requirement R22**

The VRF did not change from the previously FERC approved TOP-001-5 Reliability Standard.

**VSL Justification for TOP-001-6, Requirement R22**

The VSL did not change from the previously FERC approved TOP-001-5 Reliability Standard.

**VRF Justification for TOP-001-6, Requirement R23**

The VRF did not change from the previously FERC approved TOP-001-5 Reliability Standard.

**VSL Justification for TOP-001-6, Requirement R23**

The VSL did not change from the previously FERC approved TOP-001-5 Reliability Standard.

**VRF Justification for TOP-001-6, Requirement R24**

The VRF did not change from the previously FERC approved TOP-001-5 Reliability Standard.

**VSL Justification for TOP-001-6, Requirement R24**

The VSL did not change from the previously FERC approved TOP-001-5 Reliability Standard.

<b>VRF Justifications for TOP-001-6 R25</b>	
<b>Proposed VRF</b>	<b>High</b>
NERC VRF Discussion	
<b>FERC VRF G1 Discussion</b> Guideline 1- Consistency with Blackout Report	The VRF is consistent with the conclusions of the final Blackout Report.
<b>FERC VRF G2 Discussion</b> Guideline 2- Consistency within a Reliability Standard	The requirement has no sub-requirements so a single VRF was assigned.
<b>FERC VRF G3 Discussion</b> Guideline 3- Consistency among Reliability Standards	A VRF of High for this requirement is consistent with approved Reliability Standard FAC-014-2, Requirement R2.
<b>FERC VRF G4 Discussion</b> Guideline 4- Consistency with NERC Definitions of VRFs	Not having a methodology for determining SOL exceedances has the potential unintended consequence of creating inconsistencies in determining SOL exceedances which could directly affect the electrical state or the capability of the Bulk Electric System (BES), or the ability to effectively monitor and control the BES. However, violation of this requirement is unlikely, under emergency, abnormal, or restoration conditions anticipated by the preparations, to lead to BES instability, separation, or cascading failures, nor to hinder restoration to a normal condition.

**VRF Justifications for TOP-001-6 R25**

Proposed VRF	High
<b>FERC VRF G5 Discussion</b> Guideline 5- Treatment of Requirements that Co-mingle More than One Obligation	The requirement contains one objective, therefore, a single VRF is assigned.

**VSLs for TOP-001-6, R25**

Lower	Moderate	High	Severe
			The Transmission Operator failed to use the applicable Reliability Coordinator’s SOL methodology when determining SOL exceedances for Real-time Assessments, Real-time monitoring, and Operational Planning Analysis.

Exhibit I

Standard Drafting Team Roster  
Project 2015-09 Establish and Communicate System Operating Limits

## Standard Drafting Team Roster

Project 2015-09 Establish and Communicate System Operating Limits

	Name	Entity
<b>Chair</b>	Dean LaForest	ISO New England
<b>Vice Chair</b>	Hari Singh	Xcel Energy
<b>Members</b>	Samuel Jager	Independent Electricity System Operator
	Thomas Leslie	Georgia Transmission Corp
	Stephen Solis	Electric Reliability Council of Texas
	Aaron Staley	Orlando Utilities Commission
	Dede Subakti	California ISO
<b>PMOS Liaison</b>	Ken Lanehome	Bonneville Power Administration
<b>NERC Staff</b>	Latrice Harkness – Senior Standards Developer	North American Electric Reliability Corporation
	Darrel Richardson – Principal Technical Advisor, Standards	North American Electric Reliability Corporation
	Shamai Elstein – Assistant General Counsel	North American Electric Reliability Corporation