

**UNITED STATES OF AMERICA  
BEFORE THE  
FEDERAL ENERGY REGULATORY COMMISSION**

**Protection System Maintenance**                     )  
**Reliability Standard**                                 )

**Docket No. RM13-7-000**

**INFORMATIONAL FILING OF THE  
NORTH AMERICAN ELECTRIC RELIABILITY CORPORATION REGARDING  
COMMISSIONING TESTING OF PROTECTION SYSTEMS**

The North American Electric Reliability Corporation (“NERC”)<sup>1</sup> hereby provides the Federal Energy Regulatory Commission (“FERC” or “Commission”) an update regarding the informational filing submitted on December 19, 2014<sup>2</sup> (the “2014 Filing”) as directed in Order No. 793.<sup>3</sup> In Order No. 793, the Commission accepted Reliability Standard PRC-005-2 and NERC’s commitment to inform the Commission regarding NERC’s progress on projects to examine commissioning testing of Protection Systems. Accordingly, in the 2014 Filing, NERC provided Commission Staff with information on activities since Order No. 793 to study commissioning testing of Protection Systems and stated that NERC would inform the Commission of further progress.

This informational filing provides an overview of activities concluding work described in the 2014 Filing. In particular, on May 10, 2017, the Institute of Electrical and Electronics Engineers (“IEEE”) Power System Relaying Committee (“PSRC”) I25 working group published *Commissioning Testing of Protection Systems* (“Commissioning Testing Document”).<sup>4</sup> This

---

<sup>1</sup> The Federal Energy Regulatory Commission certified NERC as the electric reliability organization in its order issued on July 20, 2006, in Docket No. RR06-1-000. *N. Am. Elec. Reliability Corp.*, 116 FERC 61,062 (2006).

<sup>2</sup> *Informational Filing of NERC Regarding Commissioning Testing of Protection Systems*, Docket No. RM13-7-000 (Dec. 19, 2014).

<sup>3</sup> Order No. 793, *Protection System Maintenance Reliability Standard*, 145 FERC ¶ 61,253, at P 42 (2013) (“Order No. 793”).

<sup>4</sup> A copy of the IEEE PSRC, WG I-25 *Commissioning Testing of Protection Systems* is included as **Exhibit A**.

Commissioning Testing Document complements, and incorporates by reference, IEEE C37.233 *Guide for Power System Protection Testing* (“IEEE C37-233”) (attached as **Exhibit B**), to address remaining issues related to commissioning testing of Protection Systems as described in Order No. 793.

**I. Notices and Communications**

Notices and communications with respect to this filing may be addressed to the following:<sup>5</sup>

Shamai Elstein\*  
Senior Counsel  
Candice Castaneda\*  
Counsel  
North American Electric Reliability  
Corporation  
1325 G Street, N.W., Suite 600  
Washington, D.C. 20005  
(202) 400-3000  
shamai.elstein@nerc.net  
candice.castaneda@nerc.net

Howard Gugel\*  
Senior Director,  
Standards and  
Education  
North American Electric Reliability  
Corporation  
3353 Peachtree Road,  
N.E. Suite 600, North  
Tower Atlanta, GA  
30326  
(404) 446-9693  
howard.gugel@nerc.net

---

<sup>5</sup> Persons to be included on the Commission’s service list are identified by an asterisk. NERC respectfully requests a waiver of Rule 203 of the Commission’s regulations, 18 C.F.R. § 385.203 (2017), to allow the inclusion of more than two persons on the service list in this proceeding.

## II. Procedural History

### A. **Order No. 793 Directive To Report Activities Surrounding Commissioning Testing of Protection Systems**

In the Notice of Proposed Rulemaking (“NOPR”) which preceded Order No. 793, the Commission noted its concern that Reliability Standard PRC-005-2 did not include a requirement to verify that Protection System equipment and components operate as accurately as required under the standard when placed in service or modified.<sup>6</sup> In response, NERC asked the Commission to refrain from issuing a directive, describing efforts to reduce Protection System Misoperations through improved commissioning testing practices. Those efforts included:

[D]evelopment of a report by the System Protection and Control Subcommittee (SPCS), recently approved by the NERC Planning Committee, in which the SPCS “suggested improving commissioning practices through (1) analysis of protection system Misoperations; (2) sharing of lessons learned; and (3) development of an industry reference document on protection system commissioning practices.”<sup>7</sup>

NERC committed “to keep the Commission informed on the progress of these ongoing efforts to reduce protection system misoperations related to commissioning testing practices.”<sup>8</sup>

In Order No. 793, the Commission stated that while it:

[R]emain[ed] concerned about the continued possibility of misoperations resulting from a failure to properly verify the operability or settings of protection system equipment upon being placed in service or modified, we will not direct NERC to modify PRC-005-2 to include such a requirement or to otherwise develop a separate commissioning testing standard at this time. Instead, we rely on NERC’s discussion of its on-going efforts to reactively and proactively reduce protection system misoperations through improved commissioning testing practices. . . .

. . . We encourage and accept NERC’s commitment to keep the Commission informed of its efforts concerning this issue. Accordingly, we direct NERC to submit, within one year of issuance of this Final Rule, an informational filing on the status of these efforts, including the development of the guidance report as

---

<sup>6</sup> Order No. 793 at P 34 (describing, *Protection System Maintenance Reliability Standard*, NOPR, 144 FERC ¶ 61,055, at P 28 (2013)).

<sup>7</sup> *Id.* at P 37.

<sup>8</sup> *Id.*

described in the NERC Comments.<sup>9</sup>

Order No. 793, therefore, required that NERC report on efforts to execute the SPCS recommendations to (i) analyze Misoperations, (ii) share lessons learned, and (iii) develop a reference document regarding Protection System commissioning testing practices (together, “SPCS Recommendations”).

**B. The 2014 Filing Reported Completion of Two SPCS Recommendations**

As directed in Order No. 793, the 2014 Filing reported that NERC completed two of the three SPCS Recommendations.<sup>10</sup> As detailed in the 2014 Filing, after Order No. 793, (i) NERC developed improvements to Reliability Standard PRC-004, requiring analysis of Protection System Misoperations; and (ii) the SPCS published its *Lesson Learned: Verification of Alternating Current Quantities during Protection System Commissioning* (attached to the 2014 Filing). NERC has continued to use Lessons Learned to provide feedback enabling NERC to alert industry of identified issues such as those reviewed in NERC’s 2015 *Lesson Learned: Detailed Installation and Commissioning Testing to Identify Wiring or Design Errors*.<sup>11</sup>

At the time of the 2014 Filing, the only SPCS Recommendation remaining was development of a reference document on Protection System commissioning testing practices. To accomplish the third SPCS Recommendation, NERC explained that the SPCS requested the IEEE PSRC’s assistance in preparing an industry reference document on Protection System commissioning testing. The 2014 Filing described efforts by the SPCS and IEEE PSRC I25 working group to begin preparing the reference document. NERC added that it would continue to keep Commission staff apprised on these activities.<sup>12</sup>

---

<sup>9</sup> *Id.* at PP 41-42.

<sup>10</sup> 2014 Filing, at 5-9.

<sup>11</sup> Available at

[http://www.nerc.com/pa/rrm/ea/Lessons%20Learned%20Document%20Library/LL20150401\\_Detailed\\_Installation\\_and\\_Commissioning\\_Testing\\_to\\_Identify\\_Wiring\\_or\\_Design\\_Errors.pdf](http://www.nerc.com/pa/rrm/ea/Lessons%20Learned%20Document%20Library/LL20150401_Detailed_Installation_and_Commissioning_Testing_to_Identify_Wiring_or_Design_Errors.pdf).

<sup>12</sup> 2014 Filing, at 7-9.

### **III. Activities to Address Remaining SPCS Recommendations**

#### **A. Commissioning Testing Document to Address Remaining SPCS Recommendation**

As summarized above and detailed in the 2014 Filing, the SPCS asked the IEEE PSRC I25 working group to help prepare a commissioning testing reference document. In response, the IEEE PSRC I25 working group drafted a reference document to address Protection System commissioning testing in a manner that would complement and incorporate by reference an earlier IEEE document regarding Protection Systems – IEEE C37.233. In 2016, the IEEE PSRC I25 working group coordinated with the SPCS on drafts of the reference document. IEEE provided drafts Commissioning Testing Document to NERC and the SPCS in February and April of 2017. On May 10, 2017, the IEEE PSRC I25 working group finalized the Commissioning Testing Document.

On June 8, 2017, the SPCS accepted the final draft Commissioning Testing Document, when reviewed in conjunction with IEEE C37.233. The Commissioning Testing Document (attached as **Exhibit A**) provides recommendations on commissioning testing and builds upon information reviewed in IEEE C37.233 (attached as **Exhibit B**). As described in those documents, commissioning tests are intended to:

[E]valuate the condition of protection equipment after installation, but before final energization to verify that equipment is installed and wired properly, to verify that correct settings and configurations are applied, and to observe interaction with other power apparatus. The focus of the tests is to confirm that the systems function as designed.<sup>13</sup>

To support this objective, the Commissioning Testing Document provides Protection System testing protocols and other analysis techniques. With IEEE C37-233, the Commissioning Testing Document addresses overall system testing procedures for generators, lines, line reactors,

---

<sup>13</sup> Exhibit A, at 5.

transformers, capacitors, and special protection schemes. To ensure completeness and consistency with the third SPCS Recommendation, the Commissioning Testing Document must be reviewed in conjunction with IEEE C37-233.

**IV. Conclusion**

For the reasons set forth above, the Commissioning Testing Document addresses the remaining SPCS Recommendation outlined in Order No. 793. NERC respectfully requests that the Commission accept this informational filing as compliant with the Commission's directive in Order No. 793.

Respectfully submitted,

/s/ Candice Castaneda

Shamai Elstein

Senior Counsel

Candice Castaneda

Counsel

North American Electric Reliability  
Corporation

1325 G Street, N.W., Suite 600

Washington, D.C. 20005

(202) 400-3000

shamai.elstein@nerc.net

candice.castaneda@nerc.net

*Counsel for the North American Electric  
Reliability Corporation*

Date: September 20, 2017

**CERTIFICATE OF SERVICE**

I hereby certify that I have served a copy of the foregoing document upon all parties listed on the official service list compiled by the Secretary in this proceeding.

Dated at Washington, D.C. this 20<sup>th</sup> day of September, 2017.

/s/ Candice Castaneda

Candice Castaneda

*Counsel for the North American Electric  
Reliability Corporation*

## **Exhibit A**

IEEE PSRC, WG I-25 Commissioning Testing of Protection Systems



## Commissioning Testing of Protection Systems

### Assignment:

To create a report, at the request of the North American Electric Reliability Corporation (NERC) System Protection and Control Subcommittee (SPCS), to serve as an industry reference document on protection system testing practices. The SPCS believes that it would be beneficial for IEEE to produce a document on commissioning testing in an effort to help reduce the number of misoperations resulting from improper commissioning.

### Working Group Members:

R. Garcia (Chair); K. Donahoe (Vice-Chair); R. Aguilar; A. Apostolov; H. Ashrafi; J. Barsch; N. Bilimoria; J. Brown; C. Bryant; D. Buchanan; E. Carvalheira; N. Casilla; G. Halt; W. Knappek; A. Lee; B. Mackie; H. Malson; B. Moores; G. Moskos; A. Newman; L. Polanco; S. Saminfni; E. Schock; T. Seegers; M. Siira; M. Stojak; A. Uribe; J. Verzose; D. Ware; M. Wright; V. Yedidi

## Table of Contents

1.	Introduction	p5
2.	Commissioning testing of protection systems	p6
2.1	Protection system commissioning program	p6
2.2	Protection system commissioning process	p6
2.3	Planning and sequencing	p7
2.3.1	Organizing the commissioning team	p8
2.3.2	Typical PSC process sequence	p9
2.3.3	Project commission checklist	p10
2.4	Print and technical review	p11
2.5	Preparing installed equipment for modification	p12
2.6	Equipment and device acceptance testing	p12
2.6.1	Verification	p13
2.6.2	Witnessing	p13
2.6.3	Equipment assembly, logic application and acceptance testing	p13
2.7	Equipment isolation	p13
2.8	Functional testing	p14
2.8.1	Component testing	p14
2.8.2	Dc functional testing	p14
2.8.3	Marking of Prints	p15
2.8.4	Functional testing limitations when working on in-service equipment	p15
2.8.5	End-to-end testing (protection system testing)	p16
2.8.6	Operational (in-service) load checks	p17
2.8.7	Energization plan	p17
2.8.8	Switching order review	p18

2.8.9	Final walk-down	p18
2.8.10	Releasing equipment for initial energization	p19
2.8.11	Operational (in-service) tests	p19
2.8.12	Releasing equipment for service	p20
2.9	Documentation	p21
3.0	Commissioning testing of protection schemes	p22
3.1	Common considerations	p22
3.1.1	Breaker interlocks	p22
3.1.2	Testing of test switches	p22
3.1.3	Isolation of line exits with multiple CTs	p22
3.1.4	Linear couplers	p23
3.1.5	Non-conventional instrument transformers (NCITs) and merging units (MUs)	p23
3.2	Functional testing of control schemes	p23
3.3	Commissioning of batteries and chargers	p24
3.4	Commissioning of differential schemes	p25
3.5	Commissioning of line protection schemes	p26
3.5.1	Typical schemes	p26
3.5.2	Commissioning testing – recommended approach	p26
3.5.3	Input and output contact testing	p27
3.5.4	Secondary loading of instrument transformers	p27
3.5.5	Setting verification	p27
3.5.6	Secondary current injection testing	p28
3.5.7	Element testing	p28

3.5.8	Impedance characteristic testing	p28
3.5.9	Directional tests	p29
3.5.10	Distance element checks	p29
3.5.11	Reclosing tests	p30
3.5.12	Logic tests	p30
3.5.13	Dynamic tests	p30
3.5.14	End-to-end tests	p31
3.5.15	Special consideration-current differential and phase comparison relay schemes	p31
3.5.16	Errors to avoid	p31
3.5.17	Failure to remove temporary mapping of I/O	p31
3.5.18	Multiple setting groups	p32
3.5.19	Validation of polarizing quantities	p32
3.5.20	Inadvertent trips on communication assisted relay schemes using direct tripping logic	p32
Annex A (informative) – Relay commissioning common practices and checklist		p33
Annex B - (informative) Bibliography		p39

## 1. Introduction

There are many different types of protection system testing described and explained in IEEE C37.233, Guide for Power System Protection Testing [B1]. Although part of the guide covers the subject of commissioning testing of protection systems, this report is intended to strictly focus on providing recommendations on commissioning testing.

As discussed in IEEE C37.233 – 2009, the objective of commissioning tests are to evaluate the condition of protection equipment after installation, but before final energization to verify that equipment is installed and wired properly, to verify that correct settings and configurations are applied, and to observe interaction with other power apparatus. The focus of the tests is to confirm that the systems function as designed.

The guide identifies the following commissioning test objectives:

- Install and integrate the system components with the site current transformers (CTs), voltage transformer (VTs), sensors, communications systems, wiring and auxiliary power supplies.
- Verify that factory-supplied connections are correct and complete.
- Verify each component performs in accordance with vendor specifications and type testing for that component.
- Test interactions and overall system performance with samplings of test cases across the spectrum of possibilities, but not a comprehensive suite as used for factory type tests.
- Test the overall scheme by simulating power system events that cannot be generated on demand using techniques described in the guide. Examples include: transient simulation and tests for abnormal conditions.
- Operate other power apparatus or secondary control systems in the vicinity to show that the system is secure and/or dependable in the face of spurious environmental influences or communications traffic.
- Verify proper mapping and operation of the protective device with other data/control systems to which it is interconnected.

The objectives identified in the guide, are accomplished through testing protocols and other analysis techniques, as well as specific approaches to how equipment is added to the existing infrastructure.

The testing protocols and techniques are covered in the next section “Commissioning testing of protection systems.” The approaches for specific schemes are covered in the section titled “Commissioning testing of protection schemes.”

## 2. Commissioning testing of protection systems

### 2.1. Protection system commissioning program

In order to be efficient and accurate, protection systems commission testing or protection systems commissioning (PSC) requires a development and management program that serves as the source and means for executing PSC plans. This includes identifying the responsible parties for both managing and performing commissioning tasks. An effective program consists of the following key elements:

- Stated goals and objectives
- Well-defined plans to perform commissioning
- Clearly identified lines of responsibility
- Authority given to responsible parties
- Feedback methods to improve the plan

The PSC program generally achieves the following goals:

- Identify and control temporary changes to pre-existing in-service station equipment and systems while verifying that the equipment, or the overall transmission and distribution system, are not compromised as changes are made.
- Validate the acceptability and functionality of the substation equipment being installed or modified through the application of a comprehensive list of appropriate tests and measurements.
- Uncover and correct errors introduced by the designer or installation crews.
- Prepare and retain sufficient documentation that concisely displays all acceptance, functional and operational (in-service) tests have been completed.
- Identify and control the energization sequence of new or modified equipment to reduce or limit risks to the electric system.

### 2.2. Protection system commissioning process

The PSC process, often referred as the PSC procedure, is a sequence of required steps to accomplish the stated goals and objectives of the PSC program. A process should be designed using a practical performance methodology that is applicable to the items being commissioned. It must be broad enough to accommodate circuit breakers, CTs, VTs or CCVTs, relays, communication devices, batteries, and protection/control circuits. It must also be created with an appreciation for factors within the working environment such as management interaction, workforce training and experience, availability of test equipment, use of contractors and switching limitations. A successful commissioning testing process is generally supported by the following key attributes:

- A foundation in safety - There are many other important aspects of the process that must be considered, but none come before the safety of employees, contractors and the general public.
- A well-trained professional/technical staff -The professional staff, consisting mostly of engineers and technicians, must be properly trained and should have significant relevant work experience. There is no substitute for a well-trained staff and there is absolutely no equivalent substitute for experience. The process should be designed to allow those with greater experience to mentor others.
- A committed management team - The management team, a combination of local and corporate functions, must be committed to properly performing the process by balancing those competing priorities and accomplish the commissioning testing process as designed. There is often competition for time and resources that directly compete with the commissioning testing process.
- An engaged workforce - Everyone in the workforce should be fully engaged by familiarizing themselves with the goals and responsibilities of the process.
- A properly-equipped workforce – The workgroup should be equipped with the necessary tools to execute the requirements of the process as stated below.
- A focus on ensuring Bulk Electric System (BES) integrity - Maintaining the integrity of the BES is an important aspect of the commissioning process.

Although the details of the commissioning testing process can vary among utilities, there are eight core elements, listed below, that are common to most processes.

- Planning and sequencing
- Print and technical review
- Preparing installed equipment for modification
- Equipment and device acceptance testing
- Equipment isolation
- Functional testing
- Operational (or in-service load) checks
- Documentation

There are many integrated steps and activities that occur for the completion of these core process elements. Each one is covered separately in the following sections.

### 2.3. Planning and sequencing

Before the PSC plan can be developed, the responsible parties and commissioning team must be organized.

### 2.3.1. Organizing the commissioning team

For a PSC program to succeed, the responsible groups and individuals must be identified. The term “commissioning agent” describes a person, or group of persons, responsible for executing the process in a commissioning program. The commissioning agent is typically the employee, or designee, that performs on-site inspections, collects test data, provides technical guidance, consults on developing the affected switching orders and ultimately takes responsibility that the substation commissioning performed meets all company requirements. For smaller projects, the commissioning agent can be the same person that is not only directing the work but performing the work itself. On any given substation project there can be multiple entities (installation crews, test technicians, vendors, project managers, etc.) involved in the installation and testing of a substation addition or modification. The goal is to verify that these various groups have performed all necessary steps and have provided quality checking on the tests and measurements to the overlapping work scopes. In these instances, it is essential to have one point of coordination and oversight.

Responsibilities of a commissioning agent:

- Safety - A commissioning agent and their team members should perform duties and responsibilities in a safe manner. This includes actively participating in daily and spontaneous (work, crew or condition changes, etc.) job briefings and having a questioning attitude throughout the process.
- Equipment isolation support - The commissioning agent validates that adequate protection exists for in-service equipment and verifies that appropriate measures to prevent unintended tripping of transmission and distribution sources have been identified and mitigated.
- Communicating testing requirements - The commissioning agent is responsible for defining appropriate visual checks, measurements and tests required verifying the design and construction of a substation protection system modification is appropriate for the intended application. By defining the appropriate tests, a set commissioning plan is developed for individuals involved in the physical work (installation, testing, etc.). This plan is captured into a commissioning checklist, or similar tool, becoming a communication tool to individuals outside of or new to the process. It can also serve as a progress tracking method toward completion of the commissioning.
- Technical support during construction - The commissioning agent supports field installation and other test crews by resolving technical questions. They could spend a portion of their time in the field, prior to acceptance and functional testing, in order to provide timely answers to questions.
- Test leader - A commissioning agent can serve as the test leader. Although not always expected to directly perform tests themselves, all tests and measurements are performed under the test leader's direction or review whether or not they are present at the time of test.



- Field modifications - As errors are discovered through the commissioning testing process and are confirmed by the design engineer, the commissioning agent makes appropriate corrections to the initial project design and verifies appropriate testing is done. These additional tests are performed to confirm that the initial errors have been resolved and no new errors have been introduced as a result of the changes made. This may require performing additional tests, such as functional testing on circuits that were successfully tested to validate that the corrections introduced did not create new errors.
- Work verification - The purpose of commissioning testing is to verify that protection systems are installed and perform as expected to identify errors of any type, whether installation, design or manufacturer introduced. When possible, utilizing a commissioning agent who acts as a technical resource separate from the design team, the construction groups and test technicians provides additional reviews since the agent was not directly a part of the design, installation or individual tests and is less likely to introduce errors or to miss detection of errors introduced by others. Therefore, the commissioning agent is responsible in challenging all aspects of the substation's design modifications, construction and testing approach to discover and correct any mistakes before the new substation or modification to an existing substation goes into service. Formal tracking of individual steps, like checklists, are recommended for the commissioning testing plan.
- Commissioning plan or procedure - The plan provides a complete task list for testing every piece of equipment. The documentation defines the necessary scope for each organization involved in the project.
- Energization plan - A plan for the energization of new or modified substation equipment that minimizes risks to the transmission and distribution system includes determining, when appropriate, where protection schemes are temporarily modified or isolated. This involves coordinating the plan with prepared switching orders.
- Determining job completion - A commissioning agent is responsible for determining when a new substation or any new or modified substation equipment in an existing substation is ready for initial energization. They are also responsible for determining when the same equipment, after operational checks are performed, is fully functional and ready to be turned over to the appropriate dispatch organization for use.

### 2.3.2. Typical PSC process sequence

The following identifies a practical sequential approach that can be applied to every project. Reviewing the individual steps and applying all those which are applicable helps verify that the commissioning testing process is always performed in a consistent and methodical manner. The steps of the commissioning testing process are as follows:

- Verify all company safety rules are being followed.
- Obtain and review engineering print packages and verify enough sets are available for use during the commissioning testing process, including any field modifications captured during commissioning, to reflect final as-built.

- Obtain construction material list.
- Confirm one-lines, relay and Instrumentation functional diagrams, and ac & dc schematics.
- Confirm all demolition prints when used.
- Contact Telecommunication and SCADA Support groups to verify all required communication equipment and circuits are available for the project.
- Support isolation of existing protection schemes at existing substation sites.
- Identify all additions and removals.
- Develop a custom commissioning plan (procedure) to be used throughout the commissioning testing process.
- Confirm relay and associated CT settings.
- Perform new benchmark electrical equipment testing.
- Perform new CT testing.
- Perform CT current injection testing.
- Perform dc functional testing on all added or modified required control (trip and close) paths.
- Confirm test switch position as open or closed.
- Perform voltage confirmation testing.
- Re-confirm proper relay settings are in correct relays.
- Determine proper switching sequences and communicate with appropriate dispatching authorities.
- Review all test data, Commissioning plan steps and switching orders.
- Perform energization plan.
- Obtain in service load checks including angle measurements.
- Acknowledge acceptable measurements to dispatching authority and turn new or modified equipment over for their use.
- Gather, organize and file all test data and information of job (including marked up prints) in appropriate file and submit a copy of the as-built drawings to engineering to update the system of record drawings.

### 2.3.3. Project commissioning checklist

The creation of a commissioning checklist or checkout guide will greatly aid the commissioning agent(s) in tracking their progress throughout the sequence of the PSC plan.

The commissioning checklist can be an important tool used to determine a successful commissioning testing process. It provides information on the job milestones, required tests, specific procedures and tasks that must be verified, witnessed or documented by the commissioning agent. The commissioning checklist assures job continuity, especially when different groups, both internal and external, are involved in a single project. It also helps communicate what has been accomplished and what remains to be done if the job is handed off between individuals. Once created, this checklist may be discussed with all affected persons

associated with the project to clearly identify and address specific items. To installers and test crews, the checklist defines whether a testing or installation task requires coordination with the commissioning agent. If a commissioning checklist is used on the project, revisions to the commissioning checklist should be made to keep the document current and accurate.

All successfully completed steps identified in the checklist should be 'signed off' by qualified field personnel from the owning company. The owning company shall determine the process of how the checklist is documented and controlled.

“See Annex A for an example of a commissioning checklist.”

#### 2.4. Print and technical review

Before the start of any construction activity, the commissioning agent and team should review the print package. No project should begin until all the entities participating in the project have received the necessary prints. At this point, the commissioning agent studies the prints for overall applicability and accuracy. The print package generally includes the following:

- One-lines and three lines
- Relay and instrumentation diagrams
- Dc schematics
- Ac schematics
- Panel arrangement and front views
- Wiring diagrams (installation and demolition, where applicable)
- SCADA diagrams

The commissioning agent, upon review of the design package against the existing as-built substation prints and their company's design standards, develops in-depth knowledge of the modification in order to effectively lead its installation efforts and define appropriate testing.

Through this review, specific attributes of the design should be identified and validated. Some typical validation steps are as follows:

- Validates that current transformers utilized for particular relay sensing are electrically in the proper place to provide overlapping zones of protection and that their polarity conforms to standard design conventions.
- Validates that all relays that would trip a particular breaker or other fault-interrupting device are represented on all of the drawings. For example, if a line impedance relay (21) is shown to trip a breaker as represented on the one-line or similar drawing, then the dc schematic for that breaker's trip circuit should have an appropriate contact from that relay identified.

If possible design errors or deficiencies are identified in the drawings, a request for validation back to the engineering department or engineering service vendor is made. Once validated, simple corrections may be made onsite and the prints marked up for future updating. More serious problems should be sent back to the engineering department for redesign, which may require a site visit by the designer and have updated drawings issued. This approach is preferred rather than a field redesign because it confirms the commissioning agent's responsibility as an independent reviewer of the final design or in some cases, the commissioning agent may not fully understand the design intent. However, the commissioning agent may reject any prints that are considered to be technically deficient.

During this phase it is imperative an adequate configuration and document control system is in place. As prints and drawings are marked-up, changes need to be documented and all downstream documents affected and changed to the latest configuration.

## 2.5. Preparing installed equipment for modification

A critical part of a protection system addition or modification involves the temporary modification, isolation and de-energization of existing in-service protection and control equipment at the start of the project so that installation and testing can take place. If this temporary modification of the existing substation infrastructure is overlooked because it involves existing equipment, the opportunity for error exists.

The risk of error exists primarily because of the overlapping nature of protection and control schemes. Seldom is an existing protection and control scheme not put into a temporary, abnormal state while the modification and subsequent testing is going on. Verifying that these temporarily modified protection and control schemes remain functional for their intended purpose is a critical requirement early in the commissioning testing process.

Prior to switching orders being developed to isolate substation equipment in preparation for a modification, the commissioning team needs to evaluate the scope of the modification against what portions of the substation need to remain in operation, then work with the dispatch organization that prepares the switching to verify all requirements are taken into account with the prepared switching orders.

## 2.6. Equipment and device acceptance testing

Every new or modified substation component requires some basic acceptance tests performed to validate that it is not materially deficient and that any settings or adjustments are appropriate for the application. This extends beyond discrete components such as relays, instrument transformers, batteries, communication transceivers, etc. and can include panel

board wiring (e.g. insulation resistance checks), test switches (e.g. visual verification that shorting blades are made up correctly) and termination hardware (e.g. tug test on crimped connectors or sufficient stud length on terminal strips). The commissioning agent must identify exactly what tests are required to validate that the equipment added or modified is acceptable per company standards. They should be aware of the testing done offsite or at the factory.

The commissioning agent will take direct part in tasks that are critical (e.g. high degree of error possible) or are definitive to the overall success such as the dc functional testing. Other tasks or steps that are important, but have a limited chance of invalidating the design, such as CT saturation tests that only validate the performance of the CT, may simply require the commissioning agent's review of the test results performed by others.

#### 2.6.1. Verification

The commissioning agent reviews the results of a work task and attests that the work was completed in a satisfactory manner.

#### 2.6.2. Witnessing

The commissioning agent that is physically present for certain tasks verifies that the work was performed in a satisfactory manner.

Some key commissioning tasks that may require direct participation (witnessing) are:

- Dc functional tests
- Loading of CT circuits
- Initial energization
- Phasing
- Operational (or in-service) measurements of all relays

#### 2.6.3. Equipment assembly, logic application & acceptance testing

The commissioning agent verifies that all testing is performed in accordance with the utility's standards. Additionally, all testing required by the manufacturer is performed to further confirm proper operation and satisfy any warranty requirements. The commissioning agent may also give additional direction or require additional testing as warranted. Proper documentation must be made if additional testing is determined necessary.

#### 2.7. Equipment isolation

Sometimes switching orders that are prepared to establish clearance do not have enough detail. Switching orders will define elements, such as control switches (e.g. reclosing on/off

switch, transmitter send control handle, etc.), that are specifically designed to put a protection and control scheme in an abnormal state. However, other necessary isolation and modification activities, such as the shorting of CTs or the addition of jumpers to maintain a closed control path when an interlock is removed, are covered generically and do not provide specific details as to what the technicians performed.

A proper commissioning program must include an isolation log of some type that allows the installers and the commissioning team to identify, analyze and track the repositioning of individual test switches. These are the application or removal of jumpers, and other temporary measures utilized, to put existing protection and control schemes into an acceptably functioning state while system modifications are occurring. It is good practice to visually flag these affected areas to easily identify during restoration.

## 2.8. Functional testing

Functional (protection system) testing is designed to test individual components and subsystems as one cohesive system for the purpose of validating overall performance.

### 2.8.1. Component testing

There is a hierarchical approach that is taken when performing functional testing of protection and control systems. First, major subsystems such as the dc control, ac sensing, software logic and communications are tested discretely to validate their functionality and to find any wiring, design or component errors prior to an overall system functional test. For example, a validation that a carrier blocking system is working between transceivers prior to performing an end-to-end test allows a commissioning team to focus on a smaller set of possible solutions if a block signal is not being transmitted to the remote end. A second benefit to this approach is that overall system tests take more resources to perform and can take considerable time. Reducing the number of subsystem errors decreases the probability of an error during an overall systems test.

### 2.8.2. Dc functional testing

The evaluation of each protection control scheme is performed through the functional testing of trip and close paths utilizing schematic diagrams that detail the logic.

This process involves manipulating contacts, installing and removing fuses, changing the position of test switches, and all other components represented on a dc schematic in a

systematic fashion while energized from a dc source. As each component is manipulated, allowing dc current to either flow or not flow, the response of the system (e.g. illumination of a light, picking up or dropping out of a relay coil, etc.) is witnessed to validate whether the expected response is achieved. It is important to note that this testing does not only attempt to get the desired response (e.g. closing a contact results in a relay coil picking up), but also verifies that no undesired responses occur. For example, if opening a specific test switch isolates or disables a specific portion of the dc circuit under test, you must also verify that no other portions of the overall circuit are impacted in any way by the repositioning of that particular test switch. As a result of this need to verify that each component only impacts its intended part of the circuit, dc functional testing can become involved as every combination of contact and test switch combinations are checked. This type of exhaustive testing is critical to verify that the circuit is wired correctly and that no unintended circuit paths exist that may impact the overall performance of the protection and control scheme.

Methods to manipulate dc circuits:

- Actual operation of device contact is preferred
- Jumper across device contact - typical for lockout or auxiliary tripping relays that cannot be operated due to shared equipment in service
- Voltage check
- Verify existence or absence of voltage
- Use of auxiliary devices
- Use of breaker simulators

Document the methods used, in accordance with the owning company's standards, on the schematics if a method other than actual operation of the device is used. Before commissioning testing is completed, it will be necessary to verify each device contact to the breaker trip coil (or breaker simulator) and each input device (lockout coil, relay inputs, etc.)

### 2.8.3. Marking of prints

Marking up a copy of the schematics is a commonly used method of documenting the dc functional testing [B2]. The owning company shall determine how schematics are marked to show individual elements validated by testing. If properly marked, this may provide a visual indication of any circuit path that remains to be tested.

### 2.8.4. Functional testing limitations when working on in-service equipment

For new relay and control circuits, every portion of each circuit should be tested in accordance with the owning company's standards. When modifying existing relay and control schemes, all affected portions of the existing schemes require testing. Retesting all portions of the relay and control scheme, regardless of whether they were disturbed, may be preferred (depending on

the owning company's standards) to verify no unintended consequences occur, this is not always possible. For example, fully testing a new trip initiate contact from a breaker failure relay into an in-service bus differential scheme (with plans to trip all breakers) may not be possible due to outage constraints. However, even if the full relay and control scheme cannot be tested, it is still recommended that all portions of the scheme that may have been impacted by the new wiring changes should be checked to verify that the full functionality of the existing scheme remains.

#### 2.8.5. End-to-end testing (protection system testing)

End-to-end testing simulates power system events to verify that the equipment meets the project's functional requirements, as implemented in the field.

End-to-end testing is a good method of validating communication assisted transmission line protection schemes. End-to-end testing is the utilization of GPS time synchronized dynamic testing utilizing secondary current injection to test the protection system, including the communication path at both ends of a line, at the exact same time. This testing is typically applied during the commissioning of transmission line protection schemes to verify that the relay logic employed at each terminal and the communication scheme will properly operate as a system to detect and respond to faults within and external to the protected zone, as appropriate for the protection scheme being applied.

The end-to-end testing may uncover a problem not found during individual component testing. Communications scheme timers are very critical to maintain security while, at the same time, reducing the total clearing time. End-to-end testing can be used to try different channel settings until a good compromise is reached rather than making educated guesses. Definitive testing of such systems requires the use of synchronized test sets. Testing the communications channel separately, and estimating processing intervals and I/O times will not be as accurate as actually testing everything together as a unit.

Although there are techniques for performing end-to-end testing like having personnel at one terminal only, controlling the activities of the opposing terminal remotely, as presented by Schreiner and Hunter [B33], it is much more common to have personnel at both terminals.

- The following equipment is typically used to perform end-to-end testing on a typical two ended transmission line: A computer with specialized testing software that can communicate with the test equipment and relays being tested. There are several manufacturers that can provide this software. The software package is designed to allow the user to view and retrieve data, as well as adjust the settings and application logic as needed.



- The actual test sets to be used must be equipped with GPS time synchronization feature and provide the required currents and voltages. Note, it is important to verify that the test equipment used at each end is compatible or the testing may not work as expected. For example, if using test sets by unique vendors at opposite ends of the line, the differing time to respond to an input of the test sets must be determined and taken into account.
- Software to generate fault sequences and waveforms to be reproduced in the test equipment, thereby supplied to the relays to simulate expected system fault information.
- Although modern microprocessor relays can capture much, if not all, of the needed performance information, a fault recorder can also be used to monitor all the necessary test points.
- The use of the GPS clock accuracy of 10  $\mu$ s or better, at both ends of the line, verifies that there is time coordination at both terminals of the transmission line for best simulation results. An accuracy of 10  $\mu$ s is equivalent to an angle of 0.216° at 60 Hz.
- Before conducting any testing, prearrangements can be made to obtain the required data needed for the protection system event performance analysis phase.
- Develop and document end-to-end test plan

Complete end-to-end test plan includes the following:

- Relay setting orders – settings in relays at time of testing
- Personnel contact information
- Test Plan utilized during the testing
- Test Plan description and a means to track results
- Visual representation of test plan
- Relay event records captured during testing – optional

#### 2.8.6. Operational (in-service) load checks

The method of introducing new or modified station equipment to the transmission system is a very important part of any commissioning testing process. Substation modifications typically involve new or modified protective relay schemes. Until those schemes can be validated under load, their performance cannot be relied on.

#### 2.8.7. Energization plan

An energization plan is designed to minimize the impact of a misperforming relay scheme on the system. It should include whether a protective relay scheme should be enabled or disabled until operational measurements can be made.

The commissioning agent works with system protection and dispatching groups to consider the options for energizing any piece of equipment to ensure that misoperations are minimized. The extent of any outage from a misoperation is limited and that adequate clearing exists to promptly isolate any faults. Once approved, the plan can then be used to develop switching orders.

The purpose of the plan is to provide a basis and additional details on why a particular switching approach is employed rather than the norm. The plan provides these details and acts as a mechanism for proper review and signoff by technical groups such as the system protection group.

The plan may contain additional details on which operational tests and measurements will be performed. Since switching orders are typically generic on describing actions (e.g. “disable relaying” might be all that is stated on a step), the plan provides detailed steps for the energization and switching process in order to reduce human errors.

#### 2.8.8. Switching order review

The commissioning agent, working with the dispatching organization, should review the switching orders as they develop steps to restore the system and first energize the new equipment. Once the orders are created, the commissioning agent reviews and compares them to the energization plan to see if any corrections are needed.

During this review, particular focus should be placed in the following areas:

- Validation of the overall T&D system configuration versus what was assumed when the energization plan was developed.
- The location of hold points for operational checks.
- Steps involved in either putting into service or temporarily bypassing protection and control schemes.

#### 2.8.9. Final walk-down

Prior to the actual switching, the commissioning agent should complete a final walk down of the entire project to validate that all pre-energization testing and commissioning steps have been completed and that the new or modified substation equipment is ready for the application of voltage. A job briefing, which includes stepping through the entire switching order with the assigned crew, is performed. During this time, the labels on all devices identified in the switching order are confirmed and switches and breakers are placed in the appropriate starting open or close position.

#### 2.8.10. Releasing equipment for initial energization

Switching orders used for the commissioning of new or modified equipment should include a step where the commissioning agent releases the equipment for operational tests. This would allow the equipment to be energized at system voltages and for testing or analysis to be performed. This formal acknowledgement indicates that all pre-energization testing is complete and the equipment is ready for the application of system nominal voltages and currents.

#### 2.8.11. Operational (in-service) tests

This testing provides a final check and approval from the organizations involved. In-service testing demonstrates and documents the performance of protection, communication, HMI equipment (if applicable) and major electrical components.

Although the intent of the commissioning testing process is to discover and correct any errors or inherent shortcomings, the testing methods will provide opportunities for deficiencies to remain within the new or modified substation equipment. Accordingly, until system nominal voltages and currents are applied to the new or modified substation equipment and operational checks are performed, the new or modified equipment cannot be considered fully commissioned.

For protection and control schemes, this includes measuring and confirming that the voltages and currents measured at various instrument transformers and transducers are being supplied to each and every protective relay, meter, recorder, etc. These tests should also verify that the measurements are correct in magnitude, phase angle and polarity with respect to the primary quantities. Additionally, the proper metering by the relays, meters, fault recorders and other devices that use those same signals should be confirmed. If the in-service testing is performed and the line current is predicted to be below the minimum equipment requirements for current transformers, temporary load banks may be used to increase the current flow. This confirms that protective relays and other devices can be properly checked out.

Operational tests and measurements must be captured for individual protective relays and all other devices such as meters and DFRs. Prior to performing tests or capturing measurements, the expected values should be calculated based on system load flow from existing measuring devices, if available. These expected values should then be compared with the results of the live tests and measurements taken from the installed relays and other devices, confirming the phasor relationships (magnitudes and angles) and validating that what was expected is what is being captured. If differences exist during the operational tests between what is measured and

what was expected, then an analysis must be performed to determine whether the error is in the installed equipment (such as a rolled CT secondary cable), in the method applied for operational testing (such as the polarity of the meter being backward), an error in the analysis (an interpretation error) or whether there was a change in systems conditions resulting in a new baseline to compare against. Regardless of where the error(s) may lie, the commissioning agent must resolve the problem before the commissioning process can proceed to its conclusion. This may require for the deenergization or physical changes to the equipment, whether it is wiring changes, equipment replacement or setting changes. Depending on the extent of the change, additional acceptance and functional tests may be required.

It is also important, as part of the post commissioning testing process, to analyze whether the errors caught at this stage are human errors made by the commissioning agent in failing to accurately perform required tasks, or whether the testing process is incomplete and needs to be revised.

The following are prerequisites for performing an in-service test:

- Verify that the relay settings have not been changed.
- Have the approved switching orders available.
- For non-standard designs, station service instructions should be developed and submitted to related operation and maintenance groups.
- Complete testing forms and documentation for in-service testing.
- A walk down has been performed with all groups involved in the project.
- All labeling is complete in the switchyard and relay house.
- Verify that enough charging current will be available either through line loading or a load bank to operate the relays.
- Transformer tap settings have been provided, if required.
- Capacitor settings have been provided, if required.
- A one Line diagram for operation personnel has been issued.

#### 2.8.12. Releasing equipment for service

The technical aspects of the commissioning testing process are essentially complete and the equipment is ready to be turned over to the appropriate dispatching group once the equipment is fully energized and carrying sufficient load to perform all necessary operational tests. At this point, the equipment will be formally released for full operational service. By this release, the commissioning agent is indicating that there are no outstanding issues impacting the performance on the new or modified equipment and that the system operator can operate the equipment fully within the extent of its operational design without any limitations.

It is important to note that if there are limitations that remain or operational checks that hadn't been accomplished due to system limitations (e.g. insufficient load to validate that a differential relay is correctly summing its current inputs, etc.), then this final release may not be given or be given provisionally and the equipment cannot be considered as fully commissioned at this time. Additionally, there should be a procedure to identify and resolve post-commissioning issues.

## 2.9. Documentation

Keeping clear, undisputable records that support the activities performed during the commissioning testing process is essential. These records are needed to properly validate the program and serves as initial reference documentation for the first maintenance interval and in case of a misoperation investigation. A methodology for capturing, reviewing and storing records needs to be built into any commissioning testing process.

The final and important attribute of the commissioning testing process is the preparation, review and accumulation of all pertinent documentation that indicates the commissioning testing process is complete. Therefore, the final activity of a commissioning agent involves assembling the commissioning checklist, test data sheets, marked prints and other pertinent data to verify that all is complete and ready for retention within the document management system employed. This documentation, which is completed at various stages of the commissioning testing process, needs to be assembled and retained allowing easy accessibility during subsequent maintenance activities. This documentation, when completed thoroughly, provides a clear roadmap of the testing processes utilized to validate the in-service equipment. The documented dates associated with commissioning tests may also be used as the start date for the first maintenance cycle.

At a minimum, the following documents should be retained:

- A fully completed and signed commissioning checklist
- Operational test results showing the in-service magnitudes and angles of all new or modified protective relays, meters, DFRs, etc. under test.
- Final marked up sets of dc and ac schematics that will be used to update system prints (including all associated panel wiring prints that may contain any changes).
- Protective relay calibration test files
- An as-built set of relay settings including the final, down loaded settings left on any microprocessor based relay.
- End-to-end satellite testing files, when applicable (including results, such as a spreadsheet that shows relay elements that actuated for various applied faults).
- Instrument transformer and transducer test results.
- Communication channel checks.

- Battery and battery charger tests, when applicable.

### 3. Commissioning testing of protection schemes

#### 3.1. Common considerations

This section is not intended to cover all possible protection system features or schemes but presents some of the features that are common and specific schemes that generally present challenges.

##### 3.1.1. Breaker interlocks

Breaker 52a and 52b contacts are often used in protection and control circuits for electrically adjacent major equipment. Removal of the substation breaker from service without accounting for these interlocks, through the temporary addition of jumpers, can impact the functionality of the trip and close circuits of in-service equipment.

##### 3.1.2. Testing of test switches

Test switches are typically used to isolate trip outputs, breaker failure initiates (BFI's) and other dc circuit related functionalities. During functional input and output checks of equipment with test switches, verify that each test switch works as intended with both open and closed confirmation. If there is space in the panel design, descriptive labels can be installed before the functional operation test and verified during the testing and commissioning process.

##### 3.1.3. Isolation of line exits with multiple CTs

Many transmission terminals are configured in either a ring bus or breaker and a half lineup. As a result, the protective relaying employed to protect the line utilizes multiple CTs to account for all possible load sources. Depending on how the CTs are summed together and the type of test and shorting switches employed, caution must be taken to properly isolate CT contributions that are being changed and eliminated while allowing in-service current contributions not to be affected.

#### 3.1.4. Linear couplers

Linear couplers are “air core” mutual reactors used in bus differential protection in places where CT saturation is a concern. Secondary voltages are generated based on primary current flow. When looped together in series, all voltages will sum to zero. When isolating an individual linear coupler, provisions to complete the loop of the secondary wiring loop must be employed.

#### 3.1.5. Non-conventional instrument transformers (NCITs) and merging units (MUs)

The commissioning agent must engage with the test plan developers, the specific test guidance documentation of the NCIT or MU vendor, and with NCIT vendor technical support staff if required, to establish the chain of functionality from the power system signals being measured to the processing function of the protection system, and the means of commissioning testing. Properly calibrated performance of all the elements of this chain must be validated without gaps, with the results documented as specified elsewhere in this guide. The testing must include communications paths and fibers, auxiliary supplies for switchyard electronics or devices, system time synchronization means, and any binary input, low-level analog input, or control output functions of MU or switchyard-installed equipment.

### 3.2. Functional testing of control schemes

A control scheme is any scheme that operates a piece of primary equipment, such as a breaker or disconnect based on the status of other primary equipment or power system conditions. The difference from protective relaying schemes is that their primary function is not to clear faults, but rather to restore load and isolate equipment after a fault has been cleared. Examples of such schemes include, but are not limited to:

- Islanding control schemes
- Auto-transfer (‘flop-over’) schemes
- Sectionalizing schemes

These schemes can be implemented electromechanically using contacts and auxiliary relays. However, greater flexibility and functionality can be achieved when control schemes are implemented in microprocessor packages. These can either be stand-alone devices that are dedicated to performing the desired control function or part of a primary protective relaying scheme.

The operating principle for electromechanical control schemes is easily described with an elementary drawing. However, with a scheme implemented in a microprocessor relay the actual operating logic is encapsulated within the device, so the elementary drawing does not

completely describe the scheme. As a result, another drawing or piece of documentation is required to describe the programmed logic inside the relay, such as settings file or a logic diagram.

Commissioning of control schemes is a relatively straightforward process that involves the following steps:

- Checking to make sure the scheme is wired correctly per the approved elementary and wiring schematics.
- Verifying all tripping contacts are completely isolated from operating any primary equipment.
- Checking to make sure any microprocessor relay setting files have been correctly loaded onto the relay.
- Checking to make sure all binary inputs and outputs on the microprocessor relay are operating correctly.
- Checking to make sure all auxiliary relays, contacts, timers, etc. in the scheme are operating correctly.
- Verifying the scheme functions as desired according to all applicable documentation and drawings.
- Typically, control logic that is integrated into a microprocessor package can be thoroughly tested (i.e. completely proving every logic element) in a lab environment prior to field installation. In a lab environment, it is easier to simulate test cases and make adjustments to logic as necessary verifying desired scheme operation.

### 3.3. Commissioning of batteries and chargers

Any battery bank installation should be performed under battery manufacturer's recommendations or use the company's standards. The installation test results should be retained for maintenance reference (refer to NERC Standard PRC-005-6 or the most recent version for maintenance testing requirements) which can also be used during commissioning. For the particular type of battery installed, the manufacturer recommends a proper battery cell voltage, per cell, at both float and equalized values. One recommendation for a substation 125 Vdc battery system is to set the float voltage per cell to be 2.25 Vdc for a battery bank that contains 60 cells, therefore the overall battery voltage would be 135 Vdc.

IEEE [B41] provides a helpful reference guide for the installation and maintenance of substation batteries to the manufacturers' recommendations. This installation task is typically performed by substation personnel. Battery charger alarms are expected to be properly set and verified to



terminal points where the relay protection technician connects to. Examples of these alarm points are loss of battery charger A.C. voltage, and both high and low battery voltage alarm points.

It is the relay protection technician's responsibility during onset of a construction project to verify the installation of a substation battery ground detector circuit. As each new dc circuit, whether protection or control is introduced into the overall system, a battery ground detector check should be done.

A ground detector check should be performed on larger transmission substations, where there may be two independent battery systems, to make sure the systems are not wired together somewhere within the substation.

### 3.4. Commissioning of differential schemes

Differential schemes are utilized on generators, transformers and substation buses. The commissioning testing processes used in the validation of differential current circuit integrity are the same in other types of current circuits. The process includes checking for phasing, CT ratio, polarity, proper cable/wiring from CT termination block to relay terminals, and correct application and testing of relay settings.

Bus protection CT connections are usually wye connected with phase wire on the polarity terminal. Cables are terminated to the outermost CT's of the equipment, thereby overlapping the protection zones of other schemes. For high impedance bus differential schemes, the preferred solution is to have the same full CT ratio for all differential circuit sources. Be alert to cases where the full ratios do not match. For situations where CT ratios do not match, there are various solutions that can be used as referenced in B37 and B38.

Attention to phase sequence connections is needed when transformer differential protection using older conventional high impedance electromechanical relays to a wye-wye transformer have the CT's are connected delta, attention to phase sequence connections is needed.

For microprocessor-based current differential relays at initial load flow with current flowing through the relay, take an immediate reading of the phase current differential values and check the quantity of phase currents compared to another known current circuit. Immediately evaluate the accuracy of the phase angle readings. It is also possible to read the operate and restraint values in the relay directly. The operate quantity should be very low and a restraint quantity should be present.

For commission testing purposes of line current differential relays, (87L) Satellite testing executed with all equipment installed can be performed to verify all required components are operating as expected before commissioning. If performed at one location, a second relay would be required. If there is a two terminal line with new 87L relays on each end, three phase test

equipment with laptop, software program for testing and communication channel established would be required. With the actual relay settings, automated relay testing, with each relay communicating with each other, can be performed. The setting engineer can then provide fault simulation test data for go/no-go test evaluations. However, in some cases, pre-installation testing may be performed at one location with a second relay. For example, prior to installation on a two terminal line with new 87L relays on each end obtain both relays or acquire another identical relay where a bench test using fiber jumpers as the communication medium can be performed. The success of these tests would assure that the line could be energized with the newly set relays once communication channel has been validated.

### 3.5. Commissioning of line protection schemes

The commissioning of line protection schemes is considered the most complex of all relay testing. The complexity of the relays employed, the complexity of settings necessary to verify optimum performance, the use of various communication media and their impact on operations, and the distributed nature of the installations involving multiple pieces of equipment at remote locations. As a result, a detailed and methodical approach must be applied when testing a line protection scheme to verify that it will operate as intended.

#### 3.5.1. Typical schemes

- Non-communication based schemes (step distance)
- Pilot Protection
  - Direction comparison blocking (DCB)
  - Directional comparison unblocking (DCUB)
  - Permissive overreach transfer trip (POTT)
  - Permissive underreach transfer trip (PUTT)
- Direct transfer trip (DTT)
- Line differential
- Phase comparison

#### 3.5.2. Commissioning testing – recommended approach

The commissioning of line relay schemes should start from simple, discrete checks validating the functionality and completeness of each component that makes up a line relay scheme at each terminal, to then progress to complicated and encompassing tests that validate the overall scheme.

The following is a recommended sequential approach of commissioning a line protection scheme.

First, performing discrete tests, such as input/output verification checks and secondary loading of the instrument transformer circuits, are recommended. These basic tests help validate the

interconnection wiring between the relays, instrument transformers and auxiliaries. Another basic test for communication schemes, is manual operation of the transmitter/receiver to verify the communication path is intact and performing as expected. Next comes functional tests of reclosing and logic settings to assure the system will operate as intended. Afterwards, element testing, whether manually or through the use of computer aided testing software and automated macros is conducted for commissioning a line relay scheme. Even if automated test macros are utilized, a few manual tests are recommended first to provide assurance that relay elements are performing as set before progressing to automated testing where it can be difficult to know immediately whether there is a settings or element problem versus a problem with the test. Once assured that the relay elements are picking up as expected, dynamic tests are recommended. Finally, for communication assisted protection schemes time synchronized end-to-end tests are conducted. These time-intensive tests provide greater assurance that the entire line-protective system works properly as one complete unit.

A further complex sequential description of the recommended tests is as follows:

### 3.5.3. Input and output contact testing

Relay - This test regime involves cycling the inputs and outputs to validate that they are both functional and that all inputs and outputs (I/O) points are assigned correctly to the overall control scheme. Microprocessor-based relays have commands available to easily exercise the outputs. Inputs can be verified by connecting station battery voltage or dc from a test set to the proper terminals. The relay will provide target information to indicate the input is active. Extreme care must be taken to fully isolate (I/O) before testing begins to avoid inadvertent tripping or activation of control schemes.

Communication devices - such as power line carrier receiver/transmitter units, fiber optic connections, multiplexers, or other devices should all be tested at the component and component system level to confirm correct operation.

### 3.5.4. Secondary loading of instrument transformers

The purpose of secondary loading of CTs and other instrument transformers is to validate that the secondary wiring of the ac quantities is correct as designed. This includes identifying unintentional grounds or missing return paths for current circuits.

### 3.5.5. Setting verification

Relays - The method of entering settings varies according to the relay technology used. For electromechanical and static relays, manual entry of the settings for each relay element is required. This method can also be used for microprocessor based relays. Typically, the amount of data to be entered for microprocessor relays is much greater making it normal to use the

appropriate software supplied by the manufacturer instead of manual data entry. The software also allows for easy recording of the data.

Once the settings are entered, it is recommended they be verified to be as issued. When appropriate software is used for data entry, checks can be considered complete if the data is checked prior to download of the relay settings once the download is confirmed as complete. Otherwise, a check may require subsequent data entry, following all testing, by inspecting a downloaded record of the relay settings. This setting record is an essential part of the commissioning documentation.

Radios (such as transceivers) –There are settings (such as scheme timers) located in radios that work simultaneously with the settings in relays. As a pilot scheme uses information from the terminal at the remote end of the line, the settings at the remote terminal should match settings in the local radio.

Older radios – Settings will be accomplished via dip switches and jumpers located on the cards and chassis back plane. A setting standard should be compiled and based on the scheme.

#### 3.5.6. Secondary current injection testing

Although primary current injection is preferred for testing the entire path, it is not always practical with large CT ratios used making secondary current injection more common. The purpose of secondary injection testing is to check that the protection scheme from the relay input terminals onwards is functioning correctly with the settings specified. This is achieved by applying suitable inputs from a test set to the inputs of the relays, and checking if the appropriate alarm/trip signals occur.

#### 3.5.7. Element testing

- Overcurrent elements

It is recommended to check the relay characteristics over a range of input currents to confirm parameters for an overcurrent relay such as:

- The minimum current that gives operation at each current setting.
- The maximum current at which resetting takes place.
- The operating times at suitable value of current.

#### 3.5.8. Impedance characteristic testing

With the advent of computer-based control of test sets, a comprehensive check of the entire shape of a mho circle or similar is possible. This method of testing allows a tester to verify that the relay responds correctly to every test point. This complete plotting is not required, but rather necessary where the relay is expected to operate for a given fault.

For modern microprocessor relays based on sampling of voltage and current inputs, the shape of the operating characteristic is fixed by logic and cannot drift. For these relays, it is adequate

to validate at a single point that the specified setting has been properly configured. Where logic or element settings determine which zones and functions are engaged, tests of a point for each element or functional behavior may be required. Beyond this, further testing of complete characteristic shapes at multiple points will not improve the quality of a commissioning test.

#### 3.5.9. Directional tests

It is very important that element testing includes careful consideration of the directional setting values because settable impedance directional elements can affect the results of impedance plots and reach tests. Settable directional elements have impedance thresholds that can be tested. If a setting is positive, the impedance threshold, whether forward or reverse, will be tested as a reverse fault. If a setting is negative, the impedance threshold, whether forward or reverse, will be tested as a forward fault. Results are normally expressed in negative or zero sequence ohms depending on the element type.

#### 3.5.10. Distance element checks

Multiple characteristic- Relays that contain a mho and quad characteristic for the same fault type should be tested together.

Line and resistive reach - Relay operation for zone boundaries should be tested. This should include phase to phase and phase to ground faults at the line angle. If the relay has a quadrilateral setting, then the resistive and reactive reach should be tested. Also test reverse elements if set and tripping times at a standard percentage of reach, such as 50%, for each zone.

Example:

50% of Z1 reach for Z1 (50% simply confirms that there is no doubt the timer will measure Z1 pickup only, realizing the timing may be slightly different along the boundary)  
Z1 plus 50% of the difference (Z2-Z1) or equivalently, 50% of (Z1+Z2) reach for Z2 (50% confirms the timer is picking up well within Z2 but beyond Z1)  
50% of (Z2+Z3) for Z3 (50% confirms the timer is picking up well within Z3 but beyond Z2)

Note: There will be cases with long lines followed by a very short line and the timing coordination of associated zones will have to be reviewed by the relay setting engineer. From a commissioning perspective, this exercise is simply for the purpose of testing the timing that has been provided in the settings.

Voltage supervision – Recommended for testing to include simulating a single and three phase loss of voltage supply and confirm voltage supervision operation. Also, test the relay distance elements that are blocked for Voltage supervision operation in accordance with relays designed operation.

Switch on to fault (SOTF) - It is recommended to test zone phase, zone ground and any specific overcurrent element timing for a switch on to fault condition. Also test “switch on to fault” drop off times.

Load encroachment blinders - It is recommended to test that the relay is blocked for load encroachment in accordance with relays designed operation.

#### 3.5.11. Reclosing tests

Reclosing can be complex and difficult to test. Relays are now so sophisticated that the precise sequence of events should be simulated to assure a correct test. One challenge is to correctly simulate the breaker status input on the relay. In many cases, when the status does not change at the precise time the relay expects, the relay will consider it an improper operation of the breaker and proceed to lockout. For this reason, the easiest and best practice is to do a full-functional reclosing test allowing the breaker to cycle.

#### 3.5.12. Logic tests

It is critical that any user-developed logic applied to relays used is tested during commissioning to verify correct operation. An exception to this may be if a relevant ‘default’ scheme is used. This would be a logic scheme built into the relay. Such logic schemes will have been proven by the manufacturer or programmer during relay type testing eliminating the need for proving tests during commissioning. However, where a user generates the scheme logic, it is necessary to confirm that the commissioning tests conducted are adequate to prove the functionality of the scheme, in all respects, if the logic has not already been proved out by the type testing. A specific test procedure, including the following, should be prepared:

- Checking of the scheme logic specification and diagrams to verify that the objectives of the logic are achieved.
- Testing of the logic to verify that the functionality of the scheme is proven, that correct outputs occur when expected, and confirm that no output occurs when they should not for the relevant input signal combinations.

#### 3.5.13. Dynamic tests

Dynamic testing, as opposed to element testing, involves the application of fault simulations to the relay to test its response. This approach, utilizing automated test sets, validates complex relay element algorithms that cannot be easily or completely tested in a piecemeal function during element testing. The simplest test plans have three timed snapshots of voltage and current applied to the relay in succession. The first state is a “pre-fault” condition with normal voltage and load current applied to the relay long enough to satisfy memory polarization and let the relay stabilize. The second state applies the fault simulation of voltage and current, and the third state simulates the conditions following the opening of the breaker. Dynamic testing can closely approximate actual fault conditions that the relay will experience in service. Fault

values can be calculated based on the reach of the relay in secondary ohms using simple hand calculations.

#### 3.5.14. End-to-end tests

End-to-end testing provides dynamic testing of a line relay scheme and is recommended to be utilized whenever communication-based protection schemes are employed.

#### 3.5.15. Special consideration-current differential and phase comparison relay schemes

It is recommended to use end-to-end testing whenever current differential or phase comparison relay schemes are employed to protect transmission circuits. End-to-end testing is the most effective way to validate that the remote quantities are summing properly with the measured quantities at each terminal.

In a standard communications-assisted scheme, the protection functions of the local relay are not dependent on any AC quantities from the remote relay(s), but only on a simple on/off trip permission or block. Therefore, the received signals in the scheme do not need to be aligned with any local signals, meaning that as soon as remote data arrives at the local relay, the signal can be directly consumed. In a current differential scheme (or similar), for the 87L element to be tested on the power system, it has to use signals that are measured at the same instant in time from all terminals involving the protected zone. Because data transmission does not occur instantaneously and data from different terminals arrive at different times, both the local and remote data must be stored within the 87L relays. Once all the data from the same instant in time are available in the relay, it aligns all data from the same instant in time and passes the data to the 87L function for processing.

#### 3.5.16. Errors to avoid

The following are common errors made during commissioning testing of line relay schemes that can result in 1) failure to catch an error in either the design or application of a relay scheme, 2) the introduction of errors into the relay scheme by the commissioning test or 3) an inadvertent and unintentional relay operation of an in-service portion of the substation.

#### 3.5.17. Failure to remove temporary mapping of I/O

The increasingly complex nature of line relay schemes, utilizing multiple elements of with complex logical combinations, makes the testing difficult. Often, to validate if a certain element is operational, the settings are modified temporarily to map the element under test to a specific output. This is either done manually by the technician or automatically by the testing software macros. The risk, however, is that following testing all temporary mapping may not be properly removed. Care must be taken to return the as-left mapping of I/O to the intended design. Although testing software utilized is supposed to accomplish this, a final validation that the software performed correctly is recommended. For these reasons either avoid temporary

mapping if possible and conduct a full system performance test once the individual pieces have been tested. After testing is complete, the final step is to verify that the original settings are in the relay. It is recommended that prior to energization, all relay settings are confirmed to be applied properly.

#### 3.5.18. Multiple setting groups

Microprocessor based relays typically provide the ability to employ multiple sets of settings (setting groups) to provide flexibility for changing conditions on the transmission system. From this feature, a risk can arise if an unused and improperly configured setting group is left enabled on an in-service relay scheme. Therefore, when multiple setting groups are not being utilized, it is recommended that all available setting groups are supplied with the same settings. This decreases the risk that if a relay is left in a wrong setting group the correct settings are still active rather than restoring to the default settings from the manufacturer or test settings. It is recommended that prior to energization, all relay settings are confirmed to be applied properly.

#### 3.5.19. Validation of polarizing quantities

The incorrect wiring of zero sequence polarizing sources into protective relay schemes can be overlooked easily during commissioning testing because:

- Primary injection testing is not readily feasible. Most commissioning tests inject ac currents into instrument transformer secondary windings masking equipment and wiring installation errors.
- During normal system conditions, zero sequence voltage and current are not present in quantities that allow validation through meter checks, whether the installed relays are connected correctly.

#### 3.5.20. Inadvertent trips on communication assisted relay schemes using direct tripping logic

Because line relaying is naturally distributed (multiple substation terminals) there is an increased risk of human error. Just the need for proper isolation of all the relays in a given scheme, regardless of the testing method and having to deal with multiple relays at multiple sites using larger test crews, can increase the number of errors. A common error to watch for and avoid include failing to isolate or restore critical outputs (trip or breaker failure initiate), cross-connecting wrong 87L relays, forgetting to isolate the remote relays when injecting currents into the local relay or isolating communication without consideration for the impact to the trip logic at the remote terminal.



## Annex A (informative) – Relay commissioning common practices and checklist

In a typical substation construction project there are relay focused tasks that are common to all projects.

NOTE: Other qualified personnel are responsible for the substation yard, ground grid installation, installation of all substation equipment and devices including breakers, switches, power transformers, and bus. These other qualified personnel may be expected to perform the integrity tests on substation yard equipment. Check that the other responsibilities have been done and documented.

Commissioning agent or qualified relay person in charge is responsible for the following:

- Primary phase identification needs to be known with respect to corresponding phase connections of protection system inputs. During construction, verify proper phase connectivity. Walk the yard checking all bus sections with prints.
- Construction drawings (prints) should have at least four sets: one for relay construction, one for substation electrician and two other sets for after the project including a station copy and engineering set. These prints document changes are turned in for revision and have lessons learned.
- Analyze prints to see protection zone diagram has no “holes of protection” and understand how the substation is protected and controlled.
- Develop a work plan, with associated work crews and client representatives, to schedule the phases of construction work with dates, duration of work and clearance boundaries established.

### **Commissioning checklist**

What is included in a protection system commissioning checklist varies with the scope of the project. However, below are some items to be considered for applicability in any project:

- Verify CT integrity by performing normal CT testing check
- Class
- Polarity
- Ratio
- Excitation test
- Insulation checks
- Verify unused CTs are shorted and grounded
- Verify cable pulling circuit schedule is complete and accurate.
- Verify that someone has performed control cabinet wiring tightness checks.
- Verify cable wiring completed and checked to control equipment enclosure (CEE).
- Verify cable insulation checks per expected minimum ohm value.

- Verify all alarms used for local annunciation or SCADA from points in equipment to CEE and that SCADA alarms are received at the transmission control center.
- Verify CT cables are wired properly as designed, as in
  - Polarity
  - Phase
  - Wye versus delta connections and
  - Ratio

These methods can vary in performing task.

NOTE: CT ratio must match relay setting information/sheet provided by relay setting engineer.

#### **Transformers:**

- Verify transformer nameplate has correct information per design.
- Prior to energization verify transformer de-energized (No-Load) tap position is on desired tap position (A-E).
- Verify that transformer specific alarms have been checked to terminal points in control cabinet where control cables terminate. Checking that task has been done.
- Verify fans (proper direction) and pumps run when called upon both manually/automatically.
- Verify fans and pumps blocked from working during relay lock out; internal jumper removed.
- Verify tap changer controls work in transformer, remotely in CEE and via SCADA.
- Verify accuracy of remote position indicator in CEE and indication to SCADA.
- Test and operate all the sudden pressure (SP) relays on transformer per manufacturer's instructions, if not done by others.
  - NOTE: Newer, large transformers are being designed with multiple SP relays in a voting scheme that needs to be verified.
- Verify that transformer does or does not trip on low oil or high winding temperatures. Transformer may have "ON/OFF" switches to select to for above. Label normal position of switch.

#### **Breakers (fault interrupting devices):**

- Verify breaker bushing #1 position agrees with prints and manufacture drawings.
- Verify current transformer (CT) physical position in breaker,
- Example: #1 bushing at northeast corner of breaker.
- Verify all auxiliary contacts used for project circuits, 52a and 52b contacts.
- Verify functionality of breaker; open/close when called upon and emergency trip.
- Verify all alarms agree with relay prints and are checked in to CEE relays.
- Verify that battery bank and chargers have been installed correctly with integrity checks performed and test results documented per standard procedures.

- Verify that battery ground detector circuit works correctly from initial battery installation. The use of a small fuse jumper can prove circuit.
- Proper identification labels installed to show circuit numbers and description.

**Note: Dc systems, batteries and chargers are generally handled by others, commissioning personnel need to know associated commissioning work has been performed and completed**

### **Relays:**

- Verify that wiring on all relay panels is checked for correctness and that all terminations are properly tightened.
- Verify current relay setting sheets are available.
- Install “as-issued” relay settings.
- Make adjustments to relay settings if issued settings do not agree with SCADA addresses provided by another group, (i.e., communication parameters/addressing.)
- Perform the relay test function. It may be automated which may only address the enabled elements. Save the relay test results in file folder, if in electronic format, be sure to download files to backed up permanent storage to minimize the possibility of losing the data due to equipment failures.
- Once circuits have been wired and checked, turn the circuits on to perform functional testing where the logic is proved in the relays. One method of tracking which circuits have been checked is to highlight and mark the schematic wiring diagrams identifying what functions or circuits are checked. Once complete, every circuit in the schematics must be highlighted.
- If not already done, label all relays and relay panels, including test switches, with their unique identifiers to clearly identify trips, breaker failure initiates, and other test switches.
- All inputs and outputs on relays are verified and proved for sign off.
- Prove that lock out relays do what they are intended and expected to do in the project design.
- If line relay end-to-end relay checks are needed, schedule that function within the work plan.
- Relay file management is an utmost priority. Save and compare the As-Left relay settings with the As-Issued relay settings to prove accuracy prior to primary energization.

The final set of station prints should capture all changes within the project and transferred to the permanent system of record set of prints.

### **Relay and control schemes**

- Tightness check of all wiring not only terminals and lugged connections

Test insulation (Megger or equivalent test) of control wiring. Use appropriate test voltage for insulation class of wires and connected equipment to be tested. Insulation integrity test is performed cable wire to ground and each wire within cable to each other.

- Primary relay
  - Perform acceptance test
  - Ring out current circuits
  - Verify correct CT ratio applied
  - Verify correct settings applied
  - Test relay with applied setting
  - Trip check
  - Test relay with applied settings
  - Verify inputs
  - Trip checks (outputs)
  - Verify remote relay communications
  
- Redundant or Backup relay
  - Perform acceptance test
  - Ring out current circuits
  - Verify correct CT ratio applied
  - Verify correct settings applied
  - Test relay with applied setting
  - Trip check
  - Test relay with applied settings
  - Verify inputs
  - Trip checks (outputs)
  - Verify remote relay communications
  
- Control power transformer (CPT)
  - Visual inspection for damage, key interlock, draw-out, etc.
  - Ratio check
  - Set at in- service tap
  - Doble/Megger test
  
- Voltage transformer (VT or CCVT)
  - Visual inspection for damage or draw-out
  - Ratio check
  - Doble/Megger test
  
- Communications processor
  - Verify correct settings applied
  - Verify communication with each connected relay
  - Check dial-in capability from remote location
  
- SCADA control & indication

- Verify correct settings applied
- Verify communication with each connected relay
- Verify all relay alarms
- Check dial-in capability from remote location
- Line Tuner
  - Megger coaxial cable with 500Vdc or 1000Vdc insulation test set ( >10MΩ acceptable)
  - Verify lead in wire correct cable and supported on insulator
  - Verify tuner cabinet is grounded
  - Verify Coax shield only grounded in the control house
  - Verify high voltage cable terminations
  - Tune to correct frequencies
- Line Trap
  - Tune to correct frequencies
  - Verify trap is located on the bus side, not the line side
- Power line carrier
  - Transmitter
    - Verify frequency
    - Check transmit power level meets expectations
  - Check reflected power level for optimal level receiver
    - Verify frequency
    - Set and verify margins
    - Verify local receivers correctly recognize remote transmitters
- Power line carrier
  - Transfer trip transmitters
    - Verify frequency
    - Check transmit power level meet expectations
    - Check reflected power level for optimal levels
- Direct Transfer Trip
  - Transmitters
    - Verify frequency
    - Calibrate into a 50 ohm non inductive load
    - Check reflected power level for optimal levels
  - Receivers
    - Verify frequency
    - Set and verify Margins
    - Verify local receivers correctly recognize remote transmitters
    - Verify Single Channel Conditions, if applicable

- Metering
  - Program digital meters
    - Ring out current circuits
    - Ring out potential circuits
  - Correct CT ratio applied
  
- Dc batteries
  - Check batteries for proper voltage
  - Check battery charger for proper float and equalize volts
  - Check battery alarms locally and into SCADA
  - Check for any dc battery ground to dc system as each new dc circuit is introduced
  
- Miscellaneous
  - Check all heaters for proper operation
  - Check all air-conditioning for proper operation
  - Check for proper function of lights (fluorescent and incandescent)
  - Proper labeling of all equipment
  
- Phase low voltage cables to existing circuits
  
- In-service tests
  - Verify station service
  - Verify relay potential
  - CCVT PGS Operation test
  - Verify LTC operation
  - Phase (see detailed phasing procedure)
  - Load equipment
  - Relay load checks/phase angles
  
- Release for service
  - Miscellaneous: follow-up with field staff
  - Mark all field revisions on a clean set of prints or return to Engineering
  - Update maintenance management database

## Annex B (informative)

### Bibliography

- [B1] IEEE Std C37.233<sup>TM</sup>, -2009, IEEE Guide for Power System Protection Testing.
- [B2] IEEE PSRC Report, “Quality Assurance for Protection and Control Design” 2015
- [B3] ANSI C93.1-1999, American National Standard Requirements for Power-Line Carrier Coupling Capacitors and Coupling Capacitor Voltage Transformers (CCVT).
- [B4] ANSI C93.4-1984, American National Standard for Power-Line Carrier Line-Tuning Equipment.
- [B5] ANSI C93.5-1997, American National Standard Requirements for Single Function Power-Line Carrier Transmitter/Receiver Equipment  
Carrier Transmitter/Receiver
- [B6] CIGRÉ Working Group 12.09, Thermal Aspect of Transformers, “A Survey of Facts and Opinion on the Maximum Safe Operating Temperatures under Emergency Conditions,” Paris, 1995.
- [B7] CIGRÉ Working Group 12.09, Thermal Aspect of Transformers, “Survey of Power Transformer Overload Field Practices,” No. 161, 1995.
- [B8] CIGRÉ Working Group 34.10, “Analysis and Guidelines for Testing Numerical Protection Schemes,” 2000.
- [B9] Das, R., “Real-Time Simulation for Relay Performance Evaluation,” *Proceedings of the IEEE Power System Conference and Exposition (PSCE)*, New York City, October 10–13, 2004.
- [B10] Elmore, W. A., Applied Protective Relaying. St. Louis, MO: ABB Power T&D Company, 1994.
- [B11] IEC 60044-7-1999, Instrument Transformers—Part 7: Electronic Voltage Transformers (also see IEC 60044 set).
- [B12] IEC 60044-8-2002, Instrument Transformers—Part 8: Electronic Current Transformer (see also IEC 60044 set).
- [B13] IEC 60834-1-1999, Teleprotection Equipment of Power Systems, Performance and Testing—Part 1: Command Systems.

[B14] IEEE PSRC Committee Report, "Summary update of practices on breaker failure relaying," *IEEE Transactions on Power Apparatus and Systems*, vol. PAS-101, no. 3, pp. 555–563, Mar. 1982.

[B15] IEEE Std. C37.2<sup>TM</sup>-2008, IEEE Standard for Electrical Power System Device Function Numbers, Acronyms, and Contact Designations.

[B16] IEEE Std. C37.91<sup>TM</sup>-2008, IEEE Guide for Protecting Power Transformers.

[B17] IEEE Std. C37.92<sup>TM</sup>-2005, IEEE Standard for Analog Inputs to Protective Relays from Electronic Voltage and Current Transducers.

[B18] IEEE Std. C37.94<sup>TM</sup>-2002 (Reaff 2008), IEEE Standard for N times 64 Kilobit per Second Optical Fiber Interfaces between Teleprotection and Multiplexer Equipment.

[B19] IEEE Std. C37.102<sup>TM</sup>, -2006, IEEE Guide for AC Generator Protectionn.

[B20] IEEE Std. C37.103<sup>TM</sup>-2004, IEEE Guide for Differential and Polarizing Relay Circuit Testing.

[B21] IEEE Std. C37.104<sup>TM</sup>-2002 (Reaffirmed 2008), IEEE Guide for Automatic Reclosing of Line Circuit Breakers for AC Distribution and Transmission Lines.

[B22] IEEE Std. C37.109<sup>TM</sup>-2006, IEEE Guide for the Protection of Shunt Reactors.

[B23] IEEE Std. C37.111<sup>TM</sup>-1999, IEEE Standard for Common Format for Transient Data Exchange (COMTRADE) for Power Systems.

[B24] IEEE Std. C37.113<sup>TM</sup>-1999, IEEE Guide for Protective Relay Applications to Transmission Lines.

[B25] IEEE Std C37.115<sup>TM</sup>-2003, IEEE Standard for Standard Test Methods for Use in the Evaluation of Message Communications Between Intelligent Electronic Devices in an Integrated Substation Protection, Control and Data Acquisition System.

[B26] IEEE Std. C37.231<sup>TM</sup>-2006, IEEE Recommended Practice for Microprocessor-Based Protection Equipment Firmware Control.

[B27] IEEE Working Group K3 (Transformer Thermal Overload Protection), "Adaptive transformer thermal overload protection," *IEEE Transactions on Power Delivery*, vol. 16, no. 4, pp. 516–521, Oct. 2001.



[B28] Jodice, J. and Harpham, S., "End-to-end transient simulation for protection system performance testing," *Developments in the Use of Global Positioning Systems*, pp. 6/1–6/5 London, Feb. 8, 1994.

[B29] Lahoti, B. D. and Flowers, D. E., "Evaluation of transformer loading above nameplate rating," IEEE *Transactions on Power Apparatus and Systems*, vol. PAS-100, no. 4, pp. 1989–1998, Apr. 1981.

[B30] Mozina, C., et al., "Commissioning and maintenance testing of multifunction digital relays," *IEEE Industrial and Commercial Power Systems Technical Conference*, pp. 82–91, May 2–6, 2004.

[B31] North American Electric Reliability Corporation (NERC):  
[ftp://www.nerc.com/pub/sys/all\\_updl/standards/rs/PRC-005-1.pdf](ftp://www.nerc.com/pub/sys/all_updl/standards/rs/PRC-005-1.pdf).

[B32] North American Electric Reliability Corporation (NERC):  
[ftp://ftp.nerc.com/pub/sys/all\\_updl/pc/spctf/Relay\\_Maintenance\\_Tech\\_Ref\\_approved\\_by\\_PC.pdf](ftp://ftp.nerc.com/pub/sys/all_updl/pc/spctf/Relay_Maintenance_Tech_Ref_approved_by_PC.pdf).

[B33] Schreiner, Z. and Kunter, R., *Remote Controlled Testing of Communication Schemes for Power System Protection Using Satellite (GPS) Synchronization and Modern Communication Technology: A New Approach*. Houston, TX: Omicron Electronics, 2001.  
<http://www.omicron.at/en/literature-videos/papers/>.

[B34] Thompson, M., "Fundamentals and advances in breaker failure protection," *53rd Annual Georgia Tech Protective Relaying Conference*, Atlanta, GA, May 5–7, 1999.

[B35] Tziouvaras, D., et al., "The effects of conventional instrument transformer transients on numerical relay elements," *Proceedings of Western Protective Relay Conference WPRC 01*, Spokane, WA, Oct. 23–25, 2001.

[B36] Zocholl, S. E. and Guzman, A., "Thermal model in power system protection," *Proceedings of Western Protective Relay Conference WPRC 99*, Spokane, WA, Oct. 25–28, 1999.

[B37] Ge Multilin, GER-6455 Bus Differential Protection Application of PVD Relays Using Different Ratio Current Transformers

[B38] Behrendt, Ken, Costell, David, Zocholl, Standley E., "Considerations for Using High-Impedance or Low-Impedance Relays for Bus Differential Protection", Schweitzer Engineering Laboratories, Inc.

[B39] IEEE Report, "Analysis of System Waveforms and Event Data", December 2015 (Revised May 11, 2016)

[B40] IEEE Report, "Functional Protection Scheme Testing Report", January 4, 2012

[B41] 1106-2015 - IEEE Recommended Practice for Installation, Maintenance, Testing, and Replacement of Vented Nickel-Cadmium Batteries for Stationary Applications

[B42] ANSI/NETA ATS-2013 - Standard for Acceptance Testing Specifications for Electrical Power Equipment and Systems, InterNational Electrical Testing Association, Portage, MI

[B43] IEEE Std. C37.1<sup>TM</sup>-2007, IEEE Standard for SCADA and Automation Systems

## **Exhibit B**

IEEE C37.233 Guide for Power System Protection Testing



# IEEE Guide for Power System Protection Testing

---

**IEEE Power & Energy Society**

Sponsored by the  
Power System Relaying Committee

C37.233<sup>TM</sup>

Confidential

IEEE  
3 Park Avenue  
New York, NY 10016-5997, USA

11 December 2009

**IEEE Std C37.233<sup>TM</sup>-2009**

*Confidential*

# IEEE Guide for Power System Protection Testing

Sponsor

**IEEE Power System Relaying Committee**

of the

**IEEE Power & Energy Society**

Approved 11 September 2009

**IEEE-SA Standards Board**

Confidential

**Abstract:** Test approaches and procedures for the components and the overall protection and control system functions are presented. Test of equipment in the system protection scheme, associated communications equipment, auxiliary power supplies, and the control of power apparatus are addressed. Much of the testing emphasizes a bottom-up approach, in which the basic behavior of scheme components are verified first, followed by testing of interconnected components in a function-oriented assembly.

**Keywords:** application testing, commissioning testing, design testing, maintenance testing, performance assessment

Confidential

---

The Institute of Electrical and Electronics Engineers, Inc.  
3 Park Avenue, New York, NY 10016-5997, USA

Copyright © 2009 by the Institute of Electrical and Electronics Engineers, Inc.  
All rights reserved. Published 11 December 2009. Printed in the United States of America.

IEEE is a registered trademark in the U.S. Patent & Trademark Office, owned by the Institute of Electrical and Electronics Engineers, Incorporated.

**PDF: ISBN 978-0-7381-6080-1 STD95978**  
**Print: ISBN 978-0-7381-6081-8 STDPD95978**

*No part of this publication may be reproduced in any form, in an electronic retrieval system or otherwise, without the prior written permission of the publisher.*

**IEEE Standards** documents are developed within the IEEE Societies and the Standards Coordinating Committees of the IEEE Standards Association (IEEE-SA) Standards Board. The IEEE develops its standards through a consensus development process, approved by the American National Standards Institute, which brings together volunteers representing varied viewpoints and interests to achieve the final product. Volunteers are not necessarily members of the Institute and serve without compensation. While the IEEE administers the process and establishes rules to promote fairness in the consensus development process, the IEEE does not independently evaluate, test, or verify the accuracy of any of the information or the soundness of any judgments contained in its standards.

Use of an IEEE Standard is wholly voluntary. The IEEE disclaims liability for any personal injury, property or other damage, of any nature whatsoever, whether special, indirect, consequential, or compensatory, directly or indirectly resulting from the publication, use of, or reliance upon this, or any other IEEE Standard document.

The IEEE does not warrant or represent the accuracy or content of the material contained herein, and expressly disclaims any express or implied warranty, including any implied warranty of merchantability or fitness for a specific purpose, or that the use of the material contained herein is free from patent infringement. IEEE Standards documents are supplied “**AS IS.**”

The existence of an IEEE Standard does not imply that there are no other ways to produce, test, measure, purchase, market, or provide other goods and services related to the scope of the IEEE Standard. Furthermore, the viewpoint expressed at the time a standard is approved and issued is subject to change brought about through developments in the state of the art and comments received from users of the standard. Every IEEE Standard is subjected to review at least every five years for revision or reaffirmation. When a document is more than five years old and has not been reaffirmed, it is reasonable to conclude that its contents, although still of some value, do not wholly reflect the present state of the art. Users are cautioned to check to determine that they have the latest edition of any IEEE Standard.

In publishing and making this document available, the IEEE is not suggesting or rendering professional or other services for, or on behalf of, any person or entity. Nor is the IEEE undertaking to perform any duty owed by any other person or entity to another. Any person utilizing this, and any other IEEE Standards document, should rely upon his or her independent judgment in the exercise of reasonable care in any given circumstances or, as appropriate, seek the advice of a competent professional in determining the appropriateness of a given IEEE standard.

Interpretations: Occasionally questions may arise regarding the meaning of portions of standards as they relate to specific applications. When the need for interpretations is brought to the attention of IEEE, the Institute will initiate action to prepare appropriate responses. Since IEEE Standards represent a consensus of concerned interests, it is important to ensure that any interpretation has also received the concurrence of a balance of interests. For this reason, IEEE and the members of its societies and Standards Coordinating Committees are not able to provide an instant response to interpretation requests except in those cases where the matter has previously received formal consideration. A statement, written or oral, that is not processed in accordance with the IEEE-SA Standards Board Operations Manual shall not be considered the official position of IEEE or any of its committees and shall not be considered to be, nor be relied upon as, a formal interpretation of the IEEE. At lectures, symposia, seminars, or educational courses, an individual presenting information on IEEE standards shall make it clear that his or her views should be considered the personal views of that individual rather than the formal position, explanation, or interpretation of the IEEE.

Comments for revision of IEEE Standards are welcome from any interested party, regardless of membership affiliation with IEEE. Suggestions for changes in documents should be in the form of a proposed change of text, together with appropriate supporting comments. Comments on standards and requests for interpretations should be submitted to the following address:

Secretary, IEEE-SA Standards Board  
445 Hoes Lane  
Piscataway, NJ 08854  
USA

Authorization to photocopy portions of any individual standard for internal or personal use is granted by The Institute of Electrical and Electronics Engineers, Inc., provided that the appropriate fee is paid to Copyright Clearance Center. To arrange for payment of licensing fee, please contact Copyright Clearance Center, Customer Service, 222 Rosewood Drive, Danvers, MA 01923 USA; +1 978 750 8400. Permission to photocopy portions of any individual standard for educational classroom use can also be obtained through the Copyright Clearance Center.



## Introduction

This introduction is not part of IEEE Std C37.233-2009, IEEE Guide for Power System Protection Testing.

This guide focuses on the general approach and specific procedures for testing protective relaying systems that include multiple interacting relay components, auxiliary devices, and power apparatus. In the most critical applications, these system devices may interact over an extended physical or geographic area and use communications systems. The procedures focus separately on design testing, commissioning testing, routine maintenance testing, and ongoing performance assessment with a discussion of what each of these test categories aims to accomplish.

## Notice to users

### Laws and regulations

Users of these documents should consult all applicable laws and regulations. Compliance with the provisions of this standard does not imply compliance to any applicable regulatory requirements. Implementers of the standard are responsible for observing or referring to the applicable regulatory requirements. IEEE does not, by the publication of its standards, intend to urge action that is not in compliance with applicable laws, and these documents may not be construed as doing so.

### Copyrights

This document is copyrighted by the IEEE. It is made available for a wide variety of both public and private uses. These include both use, by reference, in laws and regulations, and use in private self-regulation, standardization, and the promotion of engineering practices and methods. By making this document available for use and adoption by public authorities and private users, the IEEE does not waive any rights in copyright to this document.

### Updating of IEEE documents

Users of IEEE standards should be aware that these documents may be superseded at any time by the issuance of new editions or may be amended from time to time through the issuance of amendments, corrigenda, or errata. An official IEEE document at any point in time consists of the current edition of the document together with any amendments, corrigenda, or errata then in effect. In order to determine whether a given document is the current edition and whether it has been amended through the issuance of amendments, corrigenda, or errata, visit the IEEE Standards Association Web site at <http://ieeexplore.ieee.org/xpl/standards.jsp>, or contact the IEEE at the address listed previously.

For more information about the IEEE Standards Association or the IEEE standards development process, visit the IEEE-SA Web site at <http://standards.ieee.org>.

## Errata

Errata, if any, for this and all other standards can be accessed at the following URL: <http://standards.ieee.org/reading/ieee/updates/errata/index.html>. Users are encouraged to check this URL for errata periodically.

## Interpretations

Current interpretations can be accessed at the following URL: <http://standards.ieee.org/reading/ieee/interp/index.html>.

## Patents

Attention is called to the possibility that implementation of this guide may require use of subject matter covered by patent rights. By publication of this guide, no position is taken with respect to the existence or validity of any patent rights in connection therewith. The IEEE is not responsible for identifying Essential Patent Claims for which a license may be required, for conducting inquiries into the legal validity or scope of Patents Claims or determining whether any licensing terms or conditions provided in connection with submission of a Letter of Assurance, if any, or in any licensing agreements are reasonable or non-discriminatory. Users of this guide are expressly advised that determination of the validity of any patent rights, and the risk of infringement of such rights, is entirely their own responsibility. Further information may be obtained from the IEEE Standards Association.

## Participants

At the time this guide was submitted to the IEEE-SA Standards Board for approval, the Power System Protection Testing Working Group had the following membership:

**Vahid Madani**, *Chair*  
**Hyder DoCarmo**, *Vice Chair*

Marc Achterkamp  
Mark Adamiak  
Mike Agudo  
Alexander Apostolov  
James Ariza  
Miroslav Begovic  
Robert Beresh  
Gustavo Brunello  
Dac-Phouc Bui  
Sean Chilcote  
Guy Colpron

Ratan Das  
Kelly Gardner  
Daniel Goodrich  
Anthony Giuliante  
Gene Henneberg  
Rich Hunt  
Bogdan Kasztenny  
Tim Kern  
Mladen Kezunovic  
Gary L. Kobet  
Peter McLaren  
Michael Mendik

Kalyan Mustaphi  
Damir Novosel  
Farnoosh Rahmatian  
André Santos  
Tony Seegers  
Jon Sykes  
Eric Udren  
Alfredo Vaccaro  
Benton A. Vandiver  
Jun Verzosa  
Ilia Voloh

The following members of the individual balloting committee voted on this guide. Balloters may have voted for approval, disapproval, or abstention.

William J. Ackerman  
Steven Alexanderson  
Alexander Apostolov  
Stan Arnot  
Ali Al Awazi  
Thomas Barnes  
G. Bartok  
David Basset  
Thomas Basso  
Robert Beresh  
Martin Best  
Steven Bezner  
Wallace Binder  
Kenneth Birt  
William Bloethe  
Chris Brooks  
Gustavo Brunello  
Hyder DoCarmo  
Arvind K. Chaudhary  
Stephen Conrad  
Tommy Cooper  
Jerry Corkran  
James Cornelison  
Ratan Das  
Alla Deronja  
Gary L. Donner  
Ernest Duckworth  
Donald Dunn  
Douglas J. Edwards  
Gearold O. H. Eidhin  
Gary Engmann  
Keith Flowers  
Fredric Friend  
Jeffrey Gilbert  
Anthony Giuliante  
Jalal Gohari  
Stephen Grier  
Randall Groves  
Ajit Gwal

Roger Hedding  
Charles Henville  
Lee Herron  
Gary Heuston  
Scott Hietpas  
Jerry Hohn  
Dennis Holstein  
David Horvath  
James Huddleston III  
James Ingleson  
Gerald Johnson  
James Jones  
Innocent Kamwa  
Bogdan Kasztenny  
Gael Kennedy  
Mladen Kezunovic  
Tanuj Khandelwal  
Yuri Khersonsky  
Chad Kiger  
James Kinney  
Gary L. Kobet  
Joseph L. Koepfinger  
David W. Krause  
Jim Kulchisky  
Saumen Kundu  
Chung-Yiu Lam  
Raluca Lascu  
Debra Longtin  
Federico Lopez  
William Lowe  
Bruce Mackie  
Vahid Madani  
O. Malik  
Omar Mazzoni  
Gary Michel  
Georges Montillet  
Charles Morse  
Jerry Murphy  
Dennis Nietzel  
Michael S. Newman

Joe Nims  
Gary Nissen  
Allan St. Peter  
Craig Preuss  
Iulian Profir  
Farnoosh Rahmatian  
Madan Rana  
R. Rebbapragada  
Michael Roberts  
Charles Rogers  
M. Sachdev  
Miriam Sanders  
Steven Sano  
Daniel Sauer  
Bartien Sayogo  
Thomas Schossig  
Sam Sciacca  
Tony Seegers  
Douglas Seely  
Gregory Sessler  
Devki Sharma  
Gil Shultz  
Tarlochan Sidhu  
David Smith  
James E. Smith  
Jerry Smith  
Kevin Stephan  
Charles Sufana  
Richard Taylor  
John Tengdin  
David Tepen  
Demetrios Tziouvaras  
Joe Uchiyama  
Eric Udren  
Benton A. Vandiver  
John Vergis  
Jane Verner  
Solveig Ward  
Kenneth White

When the IEEE-SA Standards Board approved this guide on 11 September 2009, it had the following membership:

**Robert M. Grow, *Chair***  
**Thomas Prevost, *Vice Chair***  
**Steve M. Mills, *Past Chair***  
**Judith Gorman, *Secretary***

John Barr  
Karen Bartleson  
Victor Berman  
Ted Burse  
Richard DeBlasio  
Andy Drozd  
Mark Epstein

Alexander Gelman  
Jim Hughes  
Richard H. Hulett  
Young Kyun Kim  
Joseph L. Koepfinger\*  
John Kulick

David J. Law  
Ted Olsen  
Glenn Parsons  
Ronald C. Petersen  
Narayanan Ramachandran  
Jon Walter Rosdahl  
Sam Sciacca

\*Member Emeritus

Also included are the following nonvoting IEEE-SA Standards Board liaisons:

Howard L. Wolfman, *TAB Representative*  
Michael Janezic, *NIST Representative*  
Satish K. Aggarwal, *NRC Representative*

Lorraine Patsco  
IEEE Standards Program Manager, Document Development

Soo Kim  
IEEE Standards Program Manager, Technical Program Development

Confidential

## Contents

1. Overview .....	1
1.1 Scope .....	1
1.2 Purpose .....	1
1.3 General .....	2
1.4 Types of applications .....	2
1.5 Types of tests .....	3
1.6 Applications for systems, schemes, and multistation testing .....	5
1.7 Considerations for testing and scheme self-monitoring .....	7
2. Normative references .....	10
3. Definitions, acronyms, and abbreviations .....	11
3.1 Definitions .....	11
3.2 Acronyms and abbreviations .....	11
4. Types of tests .....	12
4.1 Certification tests .....	12
4.2 Application tests .....	13
4.3 Commissioning tests .....	14
4.4 Maintenance tests .....	15
4.5 Example of test setup configurations and equipment (end-to-end testing) .....	18
4.6 Methods for generating test modules and cases .....	21
4.7 Analyses and retention of test results .....	26
5. Benefits and justification for different types of tests .....	30
6. Description of types of relay schemes and testing requirements .....	31
6.1 Introduction .....	31
6.2 Line protection .....	32
6.3 Transformer protection .....	43
6.4 Distribution protection .....	49
6.5 Shunt capacitor protection .....	56
6.6 Bus protection .....	58
6.7 Breaker failure protection and control .....	59
6.8 Reactor protection .....	67
6.9 Generator protection .....	68
6.10 Trip circuit logic scheme .....	70
7. Protection system communication testing .....	74
7.1 Power-line carrier testing .....	74
7.2 Functional testing of IEC 61850-based substation automation systems .....	77
7.3 Wireless communication .....	82

8. SIPS test requirements.....	83
8.1 Proof-of-concept testing .....	86
8.2 Field commissioning tests.....	87
8.3 System-wide performance testing during maintenance intervals.....	87
8.4 Validation through state estimation .....	88
8.5 Automatic and manual periodic testing of the entire scheme .....	88
9. Testing protection and control systems with unconventional voltage and current sensing inputs.....	90
9.1 Testing inputs to relays and microprocessor-based devices with low-level analog inputs per IEEE Std C37.92™-2005 [B17].....	90
9.2 Testing inputs to relays with digital interfaces per IEC 61850-9-2-2004 [B13] process bus .....	91
9.3 Testing outputs of unconventional sensors .....	94
9.4 Verification by condition-based maintenance .....	96
Annex A (informative) Bibliography .....	97
Annex B (informative) Suggested line current differential scheme testing procedure .....	100
Annex C (informative) Impact of high-impedance faults to protective relay performance and system testing .....	105
Annex D (informative) Transformer oil and winding temperature computational methods .....	108
Annex E (informative) Measuring and compensating for time delay after trigger for performing end-to-end testing using different relay test sets.....	110

Confidential

*Confidential*

# IEEE Guide for Power System Protection Testing

**IMPORTANT NOTICE:** *This guide is not intended to ensure safety, security, health, or environmental protection in all circumstances. Implementers of the guide are responsible for determining appropriate safety, security, environmental, and health practices or regulatory requirements.*

*This IEEE document is made available for use subject to important notices and legal disclaimers. These notices and disclaimers appear in all publications containing this document and may be found under the heading “Important Notice” or “Important Notices and Disclaimers Concerning IEEE Documents.” They can also be obtained on request from IEEE or viewed at <http://standards.ieee.org/IPR/disclaimers.html>.*

## 1. Overview

### 1.1 Scope

This guide covers suggested test requirements for power system protection scheme testing, system application tests, the scope and level of tests based on the application, and benefits of the overall protective schemes testing. This guide encompasses overall system testing procedures (generators, line, line reactors, transformer, capacitors, special protection schemes, end-to-end testing, distributed application within substation, etc.) and data collection requirements, as well as the test procedure definitions. This guide describes the methods, extent, and types of system tests for protection applications at various voltage levels. Control functions inherent to the protective systems are included. Importance of line testing, indirect trip applications, open/closed-loop tests, and dynamic/nonlinear tests are also covered.

### 1.2 Purpose

This guide is intended for power system protection professionals. It includes a reference list of type tests for protective devices as well as overall protection scheme performance tests for various types of protection schemes. The guide describes the methods, extent, and types of protection scheme tests. Interlocking and control functions inherent to the protective schemes are included.



### 1.3 General

Testing individual relays, or testing within the confines of one traditional protected-zone panel, is not comprehensive enough to demonstrate that the system is ready to respond to a real fault or emergency. This guide focuses on the general approach and procedures for testing protective relaying systems that include multiple interacting relay components, auxiliary devices, and power apparatus.

Many elaborate or wide area protection systems are installed to handle rare and critical events, and these systems must work as designed to avoid major system outages. Sustained operation in the field does not give the user benign opportunities to observe and correct performance issues. These systems need accurate and realistic simulation of these rare events for type testing and effective in-service maintenance tests.

This guide presents test approaches and procedures for the components of the system and the overall protection and control system functions. The testing of equipment in the system protection scheme, the associated communications equipment, the auxiliary power supplies, and the control of power apparatus are addressed. The system is tested as a functional unit when possible, but it may be necessary to test components or portions of the system in overlapping test schemes when it is not practical to test the whole system together. Much of the testing emphasizes a bottom-up approach, in which the basic behavior of scheme components is verified first, followed by testing of interconnected components in a function-oriented assembly.

The procedures focus separately on design testing, commissioning testing, routine maintenance testing, and ongoing performance assessment with a discussion of what each of these test categories aims to accomplish.

Testing recommendations in this document are intended not only to assist engineering and maintenance personnel in developing technical testing procedures, but also to help in planning testing resource requirements for discussion with utility management.

### 1.4 Types of applications

The three overlapping categories of system design and applications needing these specialized functional testing approaches are listed in 1.4.1 through 1.4.3.

#### 1.4.1 Wide area special protection schemes incorporating power system measurements from multiple substations around the network

These types of schemes utilize communications systems to combine results or distribute the control action commands. The testing challenge lies in stimulating and observing the performance of the system as installed over its extended physical domain. The user needs robust verification of both security and dependability of the protection.

#### 1.4.2 Wide or local area protection schemes based on exchange of data among relays and microprocessor-based devices on a communications data bus or local area network (LAN) or wide area network

The data communications networks perform the signal exchange previously handled by individually wired dedicated connections that the user can check with simple test instruments. The communications networks may be dedicated but are increasingly shared with other operating functions or even with the highly diverse utility information technology (IT) infrastructure. The testing challenge lies in verifying that the protection function performs with robust design margins, without imposing the need for impractical levels of expertise

in data transmission and protocols or specialized protocol analysis instruments. Testing also needs to demonstrate that no credible interference of unrelated communications traffic leaves the shared communications network unable to serve the critical protective function under test.

#### **1.4.3 Local area protection schemes with complex wired interconnections of components, input signals, and control outputs**

The objective is to verify the output or protection performance of the entire scheme over all the expected combinations or ranges of input conditions. The test can verify behavior by input stimulation and observation of the entire ensemble operating as a system. However, this may not show behavior or security margins in signals among the components, so some additional observation of these signals may be required. When a full input-to-output test requires more repetitive cases than is practical, it is sometimes acceptable to test individual components or portions of the scheme separately as long as the boundaries among the tested portions overlap. Every component or interconnection should have at least one functional test.

An example is an electromechanical transformer or generator relaying system with 10 or more relays, plus interconnecting wiring and auxiliary tripping devices such as lockout switches. Tripping and lockout operation may occur as a result of inputs to any of a number of measuring elements, each of which must be tested. In at least one case, the lockout switch should be operated and its ability to trip and lock out breakers should be confirmed. For many other test cases used to verify the relays that feed the lockout switch, the breaker tripping or the lockout switch operation can be blocked, as long as no wire or path is left untested.

### **1.5 Types of tests**

The document addresses several testing situations in detail, as discussed in 1.5.1 through 1.5.4.

#### **1.5.1 Application certification type tests in the factory or laboratory**

The objective of application certification type tests (also known as functional tests) is to verify the engineering design and performance of the system and its components through simulation of the full range of expected operating conditions. These cases can be in the form of playback of simulation results or real-time interactive testing. Typically, the developers run such type tests only on a first production sample if more than one is to be built.

In the case of playback of simulated cases, the tests rely on power system or apparatus modeling, simulation, and tools to demonstrate the security and dependability of the scheme before shipping to the site. Features include comprehensive modeling of the application, standardized test cases, large variety of test cases to exercise design, and simulation of communications and environmental challenges of a field installation. The test personnel document the test cases and results in some detail. For a specialized protection system or critical application, representatives of the end user may witness some or all of the type testing process to learn the system and gain confidence.

In general, component devices of a system under test have been or should be type-tested according to relevant standards for the physical and electrical environment. For example, protective relays are tested according to specified revisions of IEEE Std C37.90<sup>TM</sup> as well as IEEE Std C37.90.1<sup>TM</sup>, IEEE Std C37.90.2<sup>TM</sup>, and IEEE Std C37.90.3<sup>TM</sup>; such test results are documented separately. These well-defined product type tests are not discussed further in this document.

### 1.5.2 Commissioning tests (at installation site)

The objectives are to determine whether equipment was damaged or changed during shipping and field installation, to ensure that equipment is installed and wired properly, to verify that installers entered appropriate settings and option selections, and to observe interaction with the power apparatus. The test focus shifts from verification of design to verification that the system is working as designed.

The commissioning test objectives are as follows:

- a) Install and integrate the system components with the site current transformers (CTs), voltage transformer (VTs), sensors, communications systems, wiring, and auxiliary power supplies.
- b) To verify that factory-supplied connections are correct and complete.
- c) To ensure each component performs in accordance with vendor specifications and type testing for that component.
- d) Test interactions, and overall system performance, with a sampling of test cases across the spectrum of possibilities but not a comprehensive suite as is used for factory type tests.
- e) Test the overall scheme by simulating power system events that cannot be generated on demand, using techniques described in this guide. Examples include transient simulation, tests for abnormal conditions, end-to-end testing, and functional testing of applications using IEC 61850.
- f) Operate other power apparatus or secondary control systems in the vicinity to show that the system is secure and/or dependable in the face of spurious environmental influences or communications traffic.
- g) Verify proper mapping and operation of the protective device with other data/control systems to which it is interconnected.

### 1.5.3 Periodic maintenance tests

The objective is to detect in-service failures of components, wiring, interfaces, communications, or unwanted changes of setting or configuration.

- a) Assume the design requires no additional verification.
- b) Test for correctness of wiring or switching configuration that could conceivably have been changed by maintenance elsewhere in the substation, including polarity or phase rotation, and instrument transformer or other interface grounding/earthing.

Periodic testing should focus on carrying out steps that detect most in-service hardware failures and avoid additional testing that tends to reverify the design, software behavior, or the fundamental installation correctness that were already confirmed. Excessive testing risks accidental introduction of problems and work errors that leave the system unable to protect after the test is complete and the technicians have left the site. This is especially true for invasive testing that calls for taking systems out of service, disconnecting circuits, changing settings, or opening unit cases.

Note that for electromechanical relays, as well as solid-state and microprocessor-based devices, users have been accustomed to reverifying pickup characteristics during each periodic test because some internal failures can change these characteristics. Relay technicians open test switches and apply a large set of boundary tests from a computer-operated test set.

For microprocessor-based devices with self-monitoring and diagnostics, internal failures have different effects, most of which can be observed during normal operation via data communications or front-panel data checking. For example, metered nonfault data that the processor communicates or displays can show any measurement error that could influence trip characteristics. Although settings could be incorrect, they

can also be checked via data communications or the panel. The only element of the tripping chain that might need an overt periodic test is the trip contact and circuit to the breaker, and that can sometimes be tested via communications or the relay front panel. Periodic maintenance tests can thus be minimally invasive, and the risk of problems caused by maintenance activity is reduced. If the scheme is designed and installed with this opportunity in mind, the user may be then able to carry out some or all of the periodic checking without entering the substation.

In making efforts to detect every possible failure, the user should balance the risk from a missed element of low failure probability versus the maintenance risk of introducing a disruptive step to check it.

#### 1.5.4 Troubleshooting tests following operations

It is important to emphasize the value of verifying overall system performance following correct as well as incorrect operations by retrieving and analyzing sequence-of-events and oscillographic records captured from various devices and recorders for nearby disturbances. It is also suggested that correct operations also be studied to verify security and quantify nearness to trip. Some key steps in reviewing performance of relay systems after operation include the following:

- a) Periodically review the application in light of power system evolution and protection and control system changes.
- b) Analyze relay or digital fault recorder (DFR) data from disturbances for which the protection system did or did not operate.
- c) Consider correctness of logic, characteristics, and set points.
- d) When problems appear, carry out commissioning-like tests to demonstrate continuing suitability or to verify needed changes.
- e) Make and verify needed changes to the periodic test procedures.

#### 1.6 Applications for systems, schemes, and multistation testing

The document discusses examples of protection schemes and testing approaches for the following applications. In some applications, references are provided to other IEEE guides or standards where specific aspects of testing are covered.

##### *Line protection*

- Transmission
- Directional comparison pilot protection
- Multiterminal
- Tapped line configuration
- Line switching equipment integration
- Series compensated
- Shunt compensated
- Current differential or comparison
- Integrated relaying communications monitoring
- Conductor heating/sag

- Distribution circuits, including interaction with reclosers, switches, capacitor banks, monitors, load control systems, and other circuit equipment
- Integrated automatic reclosing and voltage/synch check
- Conditional single-pole tripping and reclosing

*Transformer protection*

- Multiwinding
- Phase shifting
- Tap changing
- Overload protection with distributed thermal inputs
- Distributed winding measurement or data acquisition systems
- Integrated load, life, and condition monitoring systems
- Predictive, acoustic, or partial discharge detection systems

*Bus protection*

- Low impedance
- Medium impedance
- High impedance
- Distributed measurement and control
- Configuration dependent protection zones and switching
- Postfault closing lockout
- Automatic reclosing

*Shunt capacitor protection*

*Breaker failure protection and control*

*Reactor protection*

- Voltage control
- Line reactors
- Current-limiting reactors

*Wide area special protection schemes*

- Generator or tie outage reconfiguration or load shedding
- Plant load or tie rejection
- Voltage collapse protection and restoration
- Out of step, synchrophasor-triggered, or phasor measurement unit (PMU)-based protection

*Distributed load shedding schemes*

- Frequency or voltage-based load shedding that is dependent on centralized system conditions or remote event triggers

There are many other power system apparatus, such as static VAR compensators, harmonic filters, and automatic transfer schemes, which in most cases are application specific and are not covered in this guide.

## 1.7 Considerations for testing and scheme self-monitoring

One important aspect of testing any scheme is the documentation. This documentation includes the procedures and results, verifying that tests have been conducted and schemes are performing within design and acceptable parameters. The procedures and test setups also ensure consistency in testing. Schemes can be simple, and the documentation may also be simple. When schemes are complicated and involve multiple owners and devices at sites, detailed documentation describing the steps necessary to accomplish this testing will make sure that these schemes are tested the same way each time to provide repeatability and comparison of test results. The procedures need to include test setups, equipment required, and procedures to isolate the system to be tested. When testing is conducted in an energized environment, additional steps are needed to ensure that all elements of the electric system are protected while testing is progress. Documentation of test procedures are usually retained to track performance history and for future maintenance purposes, and it is available as needed for demonstrating methods used for testing.

### 1.7.1 Built-in checks for internal or system problem identification

A critical aspect of testing is to develop an approach that can detect when the normal evolutionary changes in the power system or protective and communications systems surrounding the scheme under test threaten its ability to perform as designed. As the industry develops such adaptive testing approaches, the designers of components and systems should focus on incorporating the sensing and logic needed to look for impending trouble and make the system robust in the face of such gradual change.

For example, a system integrity protection scheme (SIPS), also known as a special protection system (SPS), might use an ON-OFF power-line carrier (PLC) channel to transmit a single critical status report between two substations. Many PLC channels are typically multiplexed through symmetric or skewed hybrids, line tuners, and capacitance coupled voltage transformers (CCVTs) and are dependent on tuned line traps and on the modal carrier propagation characteristics of the transmission line itself. For this example, the SPS is thoroughly tested during commissioning and a simplified maintenance test is periodically or automatically carried out after that. The PLC monitoring may include automatic check-back testing.

In subsequent years, several transformer taps are installed to serve new customers along the line. Additional PLC channels may be multiplexed with those that were operating at commissioning time, both on the line in question and on adjacent lines. At some point, the expanded combination of frequencies and signal levels combines with the multiplexing schemes and line propagation modes such that the simultaneous operation of two carrier sets not associated with the SPS will cancel the SPS carrier signal. If this circumstance occurs only during a fault, the SPS maintenance testing may show all is well until the SPS really must do its job. For a particular fault situation, the carrier state is not received and the SPS fails.

Although there are no convenient checklists to protect against all future changes, the designers and their testing approaches should include scheme verification in the face of routine surrounding events and changes that do not call for operation of the scheme under test or for restraint of the scheme. In the example above, using a frequency-shift carrier or continuously observable channel can combine with SPS carrier dropout monitoring that can point to trouble on the horizon.

In most cases, checks for nonfault behavior of components can passively monitor critical signals without adding links to the critical protective chain. In hard-coded or programmable logic of microprocessor-based devices, monitored critical signals can be posted as events or alarms to be checked by the user without disrupting the tripping chain. These signals can be supervised by independently programmed logic that filters the alarm cases without having any effect on tripping. The scheme designers should integrate this monitoring logic so that it is subjected to the full range of type and commissioning tests.

### 1.7.2 Drive for scheme and test simplicity

In designing for robustness, engineers often consider the effectiveness and complexity of the scheme and how it can be tested. During the engineering and design stage, consider the following factors and their impact on testing:

- Supervising elements, their setpoints, and how the elements have been optimized.
- Whether the design includes use of redundant elements, applied in parallel formation, and the impact on security/dependability of the application.
- Whether the scheme is voting or vetoing, and the impact of security/dependability of the application.
- Redundant systems may offer flexibility for testing of elements without removing protection from service during tests.
- Impact on scheme complexity: Complex systems have sometimes failed to perform adequately because of difficulty to test and/or identify fundamental design or application flaws.
- Test procedures and verification to return equipment to normal conditions after tests. Test switches and testing equipment present opportunities for test personnel to leave protective devices or systems in a nonfunctioning state.

### 1.7.3 Test from the bottom up

For all of type testing, commissioning testing, and maintenance testing, start with verification of the smallest elements to be verified. Determine what is assumed or known—for example, environmental tests have been performed on a numerical (microprocessor-based) device to be type tested in an SPS scheme; firmware design is assumed to be solid in a maintenance test. Check the points to be verified on these smallest units and then proceed to check the joint behavior of the next level of interconnected units. Continue until the highest overall system test is completed.

### 1.7.4 Overlap zones of testing

It is important to design the system and its maintenance test program for segmented testing or self-monitoring of the links in the protective chain. Maintenance verification by testing or observing segments is effective as long as the segments overlap. In other words, the interface between segments or links must be verified by observations during the test of the adjacent elements.

For example, a relay input may be isolated and a test signal applied to check for trip output via contact closure. Separately, the breaker may be tested by a manual trip. This pair of tests does not check the ability of the relay trip contact to trip the breaker—an undetected cold solder joint in the relay could pass an ohmmeter test and open up when a real trip is initiated. The overlapping test would be to apply inputs and check relay response as before and then to test breaker tripping by using the front-panel or data communications trip function to operate the breaker.

Also, there may be power system effects that need to be fed into all segments as a result of a specific segment action. Therefore, segmented testing should consider a scheme purpose and incorporate sufficient levels of overlapping to prove adequacy for overall scheme performance.

### 1.7.5 Make use of in-service experience

In many cases, faults or system events are used to validate performance of parts or whole protection systems. Events and oscillographic records are used to verify recently exercised elements of the scheme. If a relay in a scheme under test also tripped correctly for a routine fault, the trip output and trip circuit are probably working and can be left alone.

### 1.7.6 Use continuous performance checks for schemes using communications messaging

Many new protection schemes make use of control messaging or status and value reporting among multifunction relays, over an Ethernet LAN or other data communications media. The messages may be based on IEC 61850 generic object-oriented substation event (GOOSE) or generic substation state event (GSSE), modbus transmission control protocol (TCP), DNP3/TCP, or any of a number of other standard control protocols or vendor-specific protocols. Serial data links or networks such as RS422 or RS485 are also widely used for critical protection and control.

For Ethernet LANs and IEC 61850 GOOSE/GSSE applications in particular, IEEE Std C37.115™ provides reference background on the analysis of normal and transient levels of message traffic on the LAN. At the time that IEEE Std C37.115 was written, there was concern over the risk of performance degradation or lost messages due to collisions or LAN capacity during a data storm triggered by a multiple-contingency relaying situation at the substation. While system designers still need to pay attention to these possibilities, the newest LAN implementations are not vulnerable to these shortcomings. Managed Ethernet switches direct the message traffic and eliminate any opportunity for collision and message loss. Network links between microprocessor-based devices and their dedicated Ethernet switch ports operate at speeds between 10 MB/s and 1 GB/s, where a properly designed LAN will not introduce any rational level of message traffic with insignificant delays that could impact protection performance. Refer to IEEE Std 1615™ for the recommended practice for designing Ethernet networks in substations and to IEEE Std 1613™ for environmental and testing requirements.

Additionally, if the protection scheme includes application of cyber security communication links (i.e., routable protocols), it is important to verify the performance of the scheme, as well as test data communications channel integrity on a continuous basis. Refer to IEEE Std 1686™ for cyber security standards associated with devices used at substations. In such cases, communication link monitoring requires the following:

- For continuously streamed data, such as analog measurements or status reports, establish a predictable maximum time interval between messages in the never-ending transmission stream. The receiving microprocessor-based protection device with integrated communications interface then watches for the critical messages and raises an alarm if valid messages are not received in the expected time frame. This presumes that the integrity of the message is also confirmed via parity, cyclic redundancy check (CRC), or other message bit error detection methods available in the applied communications protocol. In such cases, corrupted messages can be alarmed along with missing messages.
- For transient control messages, such as a control command, it is important to define a companion nontrip monitoring message that is sent as a streaming message and used for monitoring the messaging path as explained above. The monitoring message must use the same data communications hardware, transmission path, and protocol and be as close as practical yet clearly distinguished from the rarely used control command. IEC 61850 GOOSE and GSSE messages used for control inherently offer this capability. The messages are time-tagged and constantly streamed in their quiescent state at a designer-set time interval when the station has no protection events in progress. All the relays that subscribe to a GOOSE message from a particular publishing relay watch for the stream of messages, and each can alarm if it is not receiving the stream of no-operate messages at the expected time intervals. Channel problems are thus caught when they occur as opposed to waiting for a mishandled fault to point to a



communications failure. The monitoring is complete from relay processor to relay processor, so periodic testing by personnel is neither necessary nor advisable. When a state change, such as a fault, occurs, IEC 61850 GOOSE defines a temporary acceleration of the messaging rate to ensure that all the subscribing relays have multiple opportunities to receive the critical tripping message without significant time delay.

GPS time tagging or sequential numbering of the messages can improve the quality and precision of the monitoring but is not always necessary. IEC 61850 GOOSE/GSSE includes this message identification feature by which subscribing relays can report the times of missing or corrupted messages.

## 2. Normative references

The following referenced documents are indispensable for the application of this document (i.e., they must be understood and used, so each referenced document is cited in text and its relationship to this document is explained). For dated references, only the edition cited applies. For undated references, the latest edition of the referenced document (including any amendments or corrigenda) applies.

IEEE Std C37.90™, IEEE Standard for Relays and Relay Systems Associated with Electric Power Apparatus.<sup>1,2</sup>

IEEE Std C37.90.1™, IEEE Standard for Surge Withstand Capability (SWC) Tests for Relays and Relay Systems.

IEEE Std C37.90.2™, IEEE Standard for Withstand Capability of Relay Systems to Radiated Electromagnetic Interference from Transceivers.

IEEE Std C37.90.3™, IEEE Standard for Electrostatic Discharge Tests for Protective Relays.

IEEE Std C37.99™, IEEE Guide for the Protection of Shunt Capacitor Banks.

IEEE Std C37.116™, IEEE Guide for Protective Relay Application to Transmission-Line Series Capacitor Banks.

IEEE Std C37.119™, IEEE Guide for Breaker Failure Protection of Power Circuit Breakers.

IEEE Std C57.91™, IEEE Guide for Loading Mineral-Oil-Immersed Transformers.

IEEE Std 643™, IEEE Guide for Power-Line Carrier Applications.

IEEE Std 1613™, IEEE Standard Environmental and Testing Requirements for Communications Networking Devices Installed in Electric Power Substations.

IEEE Std 1615™, IEEE Recommended Practice for Network Communication in Electric Power Substations.

IEEE Std 1686™, IEEE Standard for Substation Intelligent Electronic Devices (IEDs) Cyber Security Capabilities.

---

<sup>1</sup> IEEE publications are available from the Institute of Electrical and Electronics Engineers, 445 Hoes Lane, Piscataway, NJ 08854, USA (<http://standards.ieee.org/>).

<sup>2</sup> The IEEE standards or products referred to in this clause are trademarks of the Institute of Electrical and Electronics Engineers, Inc.

### 3. Definitions, acronyms, and abbreviations

#### 3.1 Definitions

For the purposes of this document, *The IEEE Standards Dictionary: Glossary of Terms & Definitions*<sup>3</sup> should be referenced.

#### 3.2 Acronyms and abbreviations

ATP	Alternative Transient Program
BER	bit error ratio
BF	breaker failure
BFR	breaker failure relaying
CBM	condition-based maintenance
CCVT	capacitive coupled voltage transformer
CT	current transformer
DCB	directional comparison blocking
DFR	digital fault recorder
DNP	data network protocol
DTT	direct transfer trip
DUT	device under test
DUTT	direct underreaching transfer trip
EMTP	Electromagnetic Transients Program
EHV	extra high voltage
FSK	frequency-shift keying
GOOSE	generic object-oriented substation event
GPS	global positioning satellite
GSSE	generic substation state event
GSU	generator step-up
HV	high voltage
ICT	information and communication technology
IED	intelligent electronic device
IOU	input/output unit
LAN	local area network
LD	logical device
LN	logical node
MOV	metal-oxide varistor
MU	merging unit
OOS	out of step
PLC	power line carrier
PMU	phasor measurement unit
POTT	permissive overreaching transfer trip
PSTN	public switched telephone network
PUTT	permissive underreaching transfer trip
RAS	remedial action scheme
RF	reflected frequency
RUT	relay under test
SAS	substation automation system
SCADA	supervisory control and data acquisition

<sup>3</sup> *The IEEE Standards Dictionary: Glossary of Terms & Definitions* is available at <http://shop.ieee.org/>.

SCL	substation configuration language
SDH	synchronous digital hierarchy
SER	sequence of events recorder
SIPS	special integrity protection scheme
SONET	synchronous optical network
SPS	special protection system
SWC	surge withstand capability
SWR	standing wave ratio
TMU	test merging unit
TCP	transmission control protocol
TOC	time overcurrent
TRV	transient recovery voltage
VLf	very low frequency
VT	voltage transformer

## 4. Types of tests

In this clause, different types of tests are described. Some of the tests are device specific, and others are application oriented.

### 4.1 Certification tests

Type tests are certification tests performed by a certification organization or application tests on demand of a user. Certification tests are objective and can be accepted by a wide range of users. Certification tests are normalized tests under normalized procedures and with normalized equipment. For numerical protection devices, type tests cover hardware as well as software. Each hardware or software version can be a different type. The results of these tests are acceptable to a wide range of users, independent of the application.

Certification tests consist of conformance tests and performance tests.

#### 4.1.1 Conformance tests

The goal of conformance testing is to verify the performance of the protective device or protection system against a set of predefined specifications.

- *Functional conformance tests:* Functional conformance tests verify whether the functionality of a protective function is as expected. Tests are focused on verifying the general characteristics against specification by means of signals without transients and direct current (dc) components. Functional conformance tests are generally steady-state accuracy tests.
- *Technological conformance tests:* Technological conformance tests verify the response of the protective function to external disturbances and internal failures. Technological tests cover the verification of the hardware quality, a reliability assessment, and an evaluation of the self-supervision. The verification of the hardware quality includes insulation properties and environmental conditions (electromagnetic compatibility, mechanical, and climatic).

#### 4.1.2 Performance tests

A performance test (also referred to as acceptance or type testing) is a type of certification test that describes the limits of performance of protective relays used in a specific application. The testing is a generic way to rate the performance of a specific relay. The test results clearly describe the ability of the relay to perform according to its specifications and the performance of the relay during certain types of common performance requirements and fault conditions. Test conditions are generally derived from testing

models based on a simple power system model. These types of tests are typically performed when evaluating a new relay for use on a specific power system, or, in some cases, when evaluating new firmware. See IEEE Std C37.231™-2006 [B28]<sup>4</sup> for additional information regarding firmware revision control. The severity of firmware changes can be used to determine whether a new suite of tests is needed. The general results from certification tests include operating speed, consistency and repeatability of performance, boundary conditions for optimal performance, understanding of settings methodology, and the suitability of this relay for typical applications. As an example, certification tests of a distance relay will illustrate operating speed of the distance element and the reliability of the distance element for zone boundary faults and during CCVT transients. These tests, therefore, determine the general suitability of a distance relay for extra high voltage (EHV) and high voltage (HV) protection applications.

The goal of performance testing is to verify the behavior of the protection under realizable network conditions. It includes aspects like dc offset, source-to-impedance ratio, fault resistance, various types of faults, and so on. In contrast to conformance testing, performance tests do not focus on how a certain function is performed within the protection but on what is to be expected from a function under certain power system conditions. In case of multifunctional protection, distinction can be made between function tests and scheme tests.

- *Functional performance tests:* At functional performance testing, each function is tested and evaluated separately. The performance of an individual protective function is examined in detail.
- *Scheme performance tests:* Scheme performance testing verifies the performance of a protective function under various conditions. Because numerical protection contains a large number of functionality combinations, it will be impossible to test them all. Scheme performance tests are therefore limited to a number of practical protection applications, with the protection schemes configured as applicable.

Software (firmware) upgrade of a protective function should be treated as testing a new protection type. Due to the interval of software upgrades, full replication of all tests may not be cost effective. Therefore, a limited program can be performed if, in an earlier stage, a complete type test is performed. The limited program should consist of the following:

- Tests to verify that the new or changed function works correctly.
- Tests to verify that no other functions are declining. This is more complicated because of the number of functions and possible combinations.

Some probabilistic analysis may help to determine which elements or hardware components need retesting.

## 4.2 Application tests

Application tests are driven by the user and are mostly subjective. Application tests are specific tests to determine the suitability of a relay for a specific protection system design application or location. Application tests are based on a detailed model of the power system and include performance testing against a wide variety of possible fault conditions. This type of testing typically uses transient simulation to replicate more accurately the behavior of the power system. The goal is to ensure a specific relay will perform for a specific application or location before actual installation. Although certification tests focus on specific relays, which are the basic building blocks, application tests may also be used to verify the entire protection scheme. Application tests are typically performed during the evaluation and design phases. The benefits of application testing are numerous. The application tests document that a specific relay, algorithm, or protection scheme is the correct choice for a certain set of power system conditions or criteria. It is typical, for example, to use a transient model of the specific power system, using multiple fault conditions, to determine the suitability of a distance relay. System integrity protection schemes require significant

---

<sup>4</sup> The numbers in brackets correspond to those of the bibliography in Annex A.

application testing as transient system modeling is inherently used to design the scheme and specify the scheme response to power system events.

A second benefit of application testing can be the determination of, and documentation of, appropriate settings. Application testing verifies the performance of a protection system in total response and will highlight the failure or overlap of specific elements of the scheme. The operating settings of these elements can then be modified based on the results of the application testing.

The following application tests are based on the use of transients for testing protective relays in order to simulate the behavior of the network during faulted conditions:

- Fault resistance
- Current transformer saturation
- Potential transformer transients

Commonly practiced methods of creating test files for transient testing include use of transient signals obtained from fault recorders (COMTRADE format), generating test files using simulation programs in combination with playback, or closed-loop test equipment such as real-time simulators. Refer to IEEE Std C37.111™-1999 [B25] for information related to the COMTRADE file formatting and standard.

### 4.3 Commissioning tests

Commissioning tests are intended to ensure the protection system will operate as designed after field installation. These tests verify the individual components, interactions between components, communications system, and scheme redundancy along with wiring and installation. These basic tests must be performed for any new installation or significant modification to an existing installation and are typically combinations of certification and application tests. The certification tests performed during commissioning verify that elements perform in a field installation in a manner consistent with laboratory results. This step is important for equipment with performance that varies due to environmental conditions or age of components such as electromechanical relays. Application tests performed during commissioning verify that the total installed scheme works as designed and intended, especially in regard to installation accuracy and interaction between various protection and control system components.

Commission testing is vitally important, as these tests prove that the actual installed system will work as designed. Commissioning tests can become very advanced. End-to-end testing of transmission lines is one advanced method, ensuring that units at both ends operate correctly. The most important benefit of commissioning tests is verifying that the protection and control system works in the field as it was designed. A second benefit is documentation of field performance as a benchmark for verifying performance for future tests.

For the elements or features that have been set on a device, the tests normally follow the functional hierarchy of the protection system in the following order:

- Check the available system parameters measurements and make sure that they meet the technical specifications.
- Test the enabled and configured protection elements.
- Test the built-in protection schemes.
- Test the multirelay protection schemes.

Commission testing of an entire system is also intended to verify the hard-wired or communication-based interfaces between the multiple microprocessor-based devices included in a protection scheme, or other

distributed applications. The interface with the auxiliary contacts of the breaker and its trip coils are generally included as part of the tests.

Commissioning tests may require the use of multiple synchronized test devices in order to verify the performance of protection schemes or other distributed applications. Proper simulation of abnormal conditions for each of the devices in a scheme is essential for the testing.

In summary, commission testing is used to make sure the protection system is properly installed and working as expected in a substation.

#### 4.4 Maintenance tests

Maintenance tests are specific tests to validate that the protection and control system is operating correctly after a period of time of field installation. Some of these tests are calibration tests to confirm that individual components are still operating within desirable performance parameters. This type of test is especially vital for the components susceptible to degraded or changing characteristic due to aging and wear. Another type of test is application tests. Application tests are performed to verify that the total protection system works, from measurement of power system values, to properly identifying fault characteristics, to the operation of the interrupting device and associated interlocking with automatic or manual restoration devices and schemes. One form of maintenance testing involves performing forced outage of protective equipment when performance of the respective scheme is identified as questionable and immediate attention to servicing the relay or the scheme is needed.

There are different philosophies concerning when it is appropriate to perform maintenance tests in an attempt to best balance assurance that the protection system will perform correctly versus the costs involved in maintaining the system. Aside from forced outage testing, there are two basic methodologies in use that are time-based maintenance and condition-based maintenance practices.

Periodic maintenance testing is performed to ensure that the protection and control system is operating correctly after a period of time of field installation. These tests may be used to ensure that individual components are still operating within acceptable performance parameters—this type of test is needed for components susceptible to degraded or changing characteristics due to aging and wear. Full system performance tests may be used to confirm that the total protection system functions from measurement of power system values, to properly identifying fault characteristics, to the operation of the interrupting device and associated interlocking with automatic or manual restoration devices and schemes.

Time-based maintenance is based on scheduled intervals for review and maintenance of the system, to demonstrate that routine testing of the system and system components are performed. Test schedules are generally determined by operating experience with a system or device, manufacturer's recommendations, and the availability of resources to perform the testing. Periodic testing may include a review of the recent power system activities on the particular terminal and whether the entire protective system has operated correctly since the last scheduled interval. If it is determined that a protection system and scheme has performed correctly, the interval may be adjusted based on most recent operational experience on the respective terminal. Similar to performance-based maintenance, condition-based maintenance includes examination of the relay system, history of specific systems and devices, and operating experience to perform maintenance only when necessary to ensure adequate performance of the protection system.

Intelligent electronic devices, such as microprocessor-based protective relays, add an additional form of maintenance testing, which is the ability to perform continuous self-monitoring for correct performance of the device. Self-monitoring capabilities vary between devices and may include the ability to monitor the incoming analog measuring circuits, the device output contacts, time synchronization signals, communications signals, internal hardware (including battery status and system board voltages), nonvolatile erasable programmable read-only memory, and the internal software algorithms. Failure of a self-test routine typically generates an alarm available through supervisory control and data acquisition

(SCADA) communications and output contacts. Certain self-test alarms may disable the functioning of the device.

Troubleshooting operating problems, from a protection system testing perspective, is generally a combination of commissioning tests and calibration tests, designed to identify specific components or specific parts of the protection system design that do not provide the desired operation results. Troubleshooting always involves good engineering practices and experience to identify the cause of operating problems.

#### 4.4.1 Maintenance practices

Maintenance and test programs that often incorporate the following types of maintenance practices:

- a) *Time-based maintenance (TBM)*—Externally prescribed maximum maintenance or testing intervals are applied for components or groups of components. The intervals may have been developed from prior experience or manufacturers' recommendations. The TBM verification interval is based on a variety of factors, including experience of the particular asset owner, collective experiences of several asset owners who are members of a country or regional council, and so on. The maintenance intervals are fixed and may range in number of months or in years.  
  
TBM can include review of recent power system events near the particular terminal. Operating records may prove that some portion of the protection system has operated correctly since the last test occurred. If specific protection scheme components have demonstrated correct performance within specifications, the maintenance test time clock is reset for those components.
- b) *Performance-based maintenance (PBM)*—Maintenance intervals are established based on analytical or historical results of TBM failure rates on a statistically significant population of similar components. Some level of TBM is generally followed to justify continued use of PBM-developed extended intervals for low occurrence of test failures or in-service failures.
- c) *Condition-based maintenance (CBM)*—Continuously or frequently reported results from nondisruptive self-monitoring of components demonstrate operational status as those components remain in service. Whatever is verified by CBM does not require manual testing, but taking advantage of this requires precise technical focus on exactly what parts are included as part of the self-diagnostics. Microprocessor-based protective relays that perform continuous self-monitoring to verify correct operation of most components within the device. Self-monitoring capabilities may include the alternating current (ac) signal inputs, analog measuring circuits, processors and memory for measurement, protection, data communications, trip circuit monitoring, and protection or data communications signals. For those conditions, failure of a self-monitoring routine generates an alarm and may inhibit operation to avoid false trips. When internal components, such as critical output relay contacts, are not equipped with self-monitoring, they can be manually tested. Method of testing may be local or remote, or through inherent performance of the scheme during a system event.

The TBM is the overarching maintenance process of which the other types are subsets. Unlike TBM, PBM intervals are adjusted based on good or bad experiences. The CBM verification intervals can be hours or even milliseconds between nondisruptive self-monitoring checks within or around components as they remain in service.

TBM, PBM, and CBM can be combined for individual components, or within a complete protection system. Figure 1 illustrates the relationship between various types of maintenance practices described in this section. In the Venn diagram, the overlapping regions show the relationship of TBM with PBM historical information and the inherent continuous monitoring offered through CBM. This figure shows:

- *Region 1*: The TBM intervals that are increased based on known reported operational condition of individual components that are monitoring themselves.
- *Region 2*: The TBM intervals that are adjusted up or down based on results of analysis of maintenance history of a statistically significant population of similar products that have been subject to TBM.
- *Region 3*: Optimal TBM intervals based on regions 1 and 2.

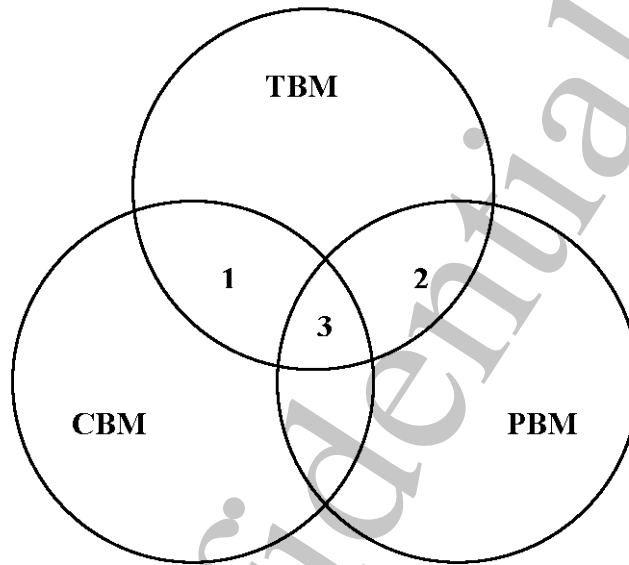

**Figure 1—Relationship of time-based maintenance types**

#### **4.4.2 Regulatory considerations**

It is important to the reliability of the electric system that protection and control systems function properly. Malfunctioning systems can contribute to major power system outages and widespread cascading events. Maintenance programs have demonstrated benefits in uncovering problems and allowing the problems to be addressed under a controlled power system environment. It is important to follow prudent maintenance programs to uncover problems and hidden failures in advance.

The effectiveness of a maintenance program is often tracked and determined by the asset owner. These tracking mechanisms allow the owner to optimize the program based on the application. However, when the performance of a protective device or system has a greater impact to the overall power system, the proper performance of the protective system will benefit the entire electrical grid, which may be composed of several interconnected power systems, or in some cases possibly part of a regulatory controlled electric system. In some countries or electrical grid systems, the regulatory agency may require evidence that the asset owners each have established a prudent maintenance program that meets a minimum level of standards and practices established by the regulatory body. Furthermore, the regulatory agency may require evidence that the owner is performing maintenance based on the program. Depending on the level of regulatory oversight, the asset owners may be asked periodically to either voluntarily, or through a cohesive and collective established audit process, or both, demonstrate that they have met their obligations to maintain the protection and control system.



In a regulatory system, the owner may be asked to certify that he or she can perform the following tasks:

- Demonstrate and submit detailed maintenance records and that asset owners are cognizant that regulatory agencies may require verification of the maintenance program, including evidence that protection systems and components are being maintained and tested per the owner's program.
- Submit a program documenting the methodology or philosophy behind the owner's program.
- Show a tracking mechanism and archiving system for the maintenance records related to the protection and control equipment and systems.

An example of a regulatory agency that establishes reliability standards and compliance measures is the North American Electric Reliability Corporation (NERC). NERC has established some standards and requirements (see NERC [B33]) of a Protection System Maintenance Program and a technical document that describes maintenance program options (NERC [B34]).

NERC and its regional reliability organizations (RROs) audit asset owning organizations across North America for compliance with these maintenance standards. Organizations found to be deficient in compliance with these standards are subject to serious fines, depending on the severity of the infraction, and they must also carry out a corrective action program.

For example, the NERC Standard for Protection System Maintenance and Testing is enforced for the bulk electric system. This standard does not impose specific test or maintenance procedures, or time intervals. Rather, it requires the asset owner to establish its own maintenance practices and include the following:

- A documented maintenance program.
- A documented basis for that program.
- Documentation that tracks the program and proves that it is being carried out as described, consistently and completely.

Note that the NERC definition of a protection system includes all of the following:

- Protective relays.
- Instrument transformers and sensors of electrical quantities needed for fault protection.
- Communications systems needed for relaying or protective tripping.
- DC station batteries supplying the protection system.
- Breaker tripping and control circuits, including auxiliary tripping and lockout relays, and primary equipment status indications required for correct relaying operation.

Similar programs are established in other interconnected electrical systems and countries.

#### **4.5 Example of test setup configurations and equipment (end-to-end testing)**

To perform end-to-end testing, some basic equipment is needed at both ends of the line under test. In this subclause, a list of recommended equipment is provided for reference purposes. This listing can be used in conjunction with the established testing practices of the owner of the protection equipment. The following description applies specifically to two terminal lines but can be extrapolated to three or more terminals by including additional sets of equipment and the necessary personnel.

This list of recommended equipment is based on having qualified personnel and equipment at both ends of the transmission line for which the protection is being tested. There are techniques for having personnel at one terminal only and remotely controlling the activities at the opposing terminal. Refer to Schreiner and Kunter [B35] for more information.

The following equipment is recommended for use in the end-to-end testing of transmission lines.

a) *Test equipment*

- 1) Interface to microprocessor-based device: A computer with appropriate manufacturer-specific software is often used in order to communicate with the microprocessor-based device under test to monitor performance, view/retrieve data, and possibly modify settings and application logic.
- 2) Test equipment: To test the devices, test equipment capable of being time synchronized and to provide three-phase voltages and currents are often used. In some cases, such as line differential, three-phase voltages may not be essential but are useful for testing the performance of ancillary or backup functions.
- 3) Fault simulation software: Software is needed that can generate fault sequences. The output from this software is used by the primary injection equipment and provides the sequence information and waveforms necessary for the test. This software may be associated with the specific primary injection equipment or may be some third-party software that has output data format compatibility with the primary injection test equipment.
- 4) Fault recorders: To monitor all the requisite test points, the use of a fault recorder at each site may be needed to capture information that is not already recorded by the microprocessor-based device.
- 5) Time coordination: Time coordination at both terminals of the transmission line is essential in performing end-to-end tests. A global positioning satellite (GPS) receiver that provides an accuracy of 10  $\mu$ s (which is equivalent to an angle of 0.216° at 60 Hz) or better should be used. A suitable GPS receiver is required at both ends of the transmission line.

NOTE—Existing GPS receivers at the test sites may be loaded to their maximum output capability, and it would be prudent to check that enough signal strength is available prior to commencing the test. An oscilloscope can be used to measure the voltage level of the GPS signal, and this can be compared with manufacturer specifications. The GPS signal is connected to both the microprocessor-based device under test and the test equipment. This time synchronization is used to coordinate the start of the test cycle at both ends of the transmission line and to time-stamp the data accurately. Signal strength at the receiving end should be verified prior to testing.<sup>5</sup>

- 6) Miscellaneous equipment: In addition to the above equipment, standard miscellaneous devices and components such as multimeters, connector cables from the microprocessor-based device to the laptop, jumpers, tools, and test leads may also be required for testing purposes.

b) *Communication equipment*

- 1) Data: Many multiterminal protections (for example, line differential relays) pass such data as voltage, current, trip signals, and time stamps among each other over existing communication channels in the normal course of operation. Additional data transmission requirements for testing purposes may not be necessary in these cases. For protection schemes where power system data is not normally passed from one terminal to the other (for example, distance protections where only a permissive signal may be sent), some additional method may be required such as a modem connection. However, this data transmission requirement may not be necessary in most cases as coordinated testing schemes from test equipment can be used and data can be retrieved from the test equipment and microprocessor-based devices at each site after the tests are completed. In the planning stages of the test, determine what data are required at both ends during the test and how to obtain that data.

---

<sup>5</sup>Notes in text, tables, and figures of a standard are given for information only and do not contain requirements needed to implement this standard.

- 2) Voice: A voice channel is necessary for staff to communicate with each other and system control operators. This channel can be anything that is convenient and reliable such as a cell phone or microwave/fiber channel.

The configuration in Figure 2 can be used to perform end-to-end testing of a two-terminal transmission line. The test equipment injects required three-phase voltages and currents into the protection under test. The test equipment also monitors the trip output, breaker failure initiate, transfer trip receive, and transfer trip send signals from the protection. GPS satellite receiver clock synchronization is used in order to allow comparison of data between the two terminals. More detailed description of end-to-end testing is available in the line protection section.

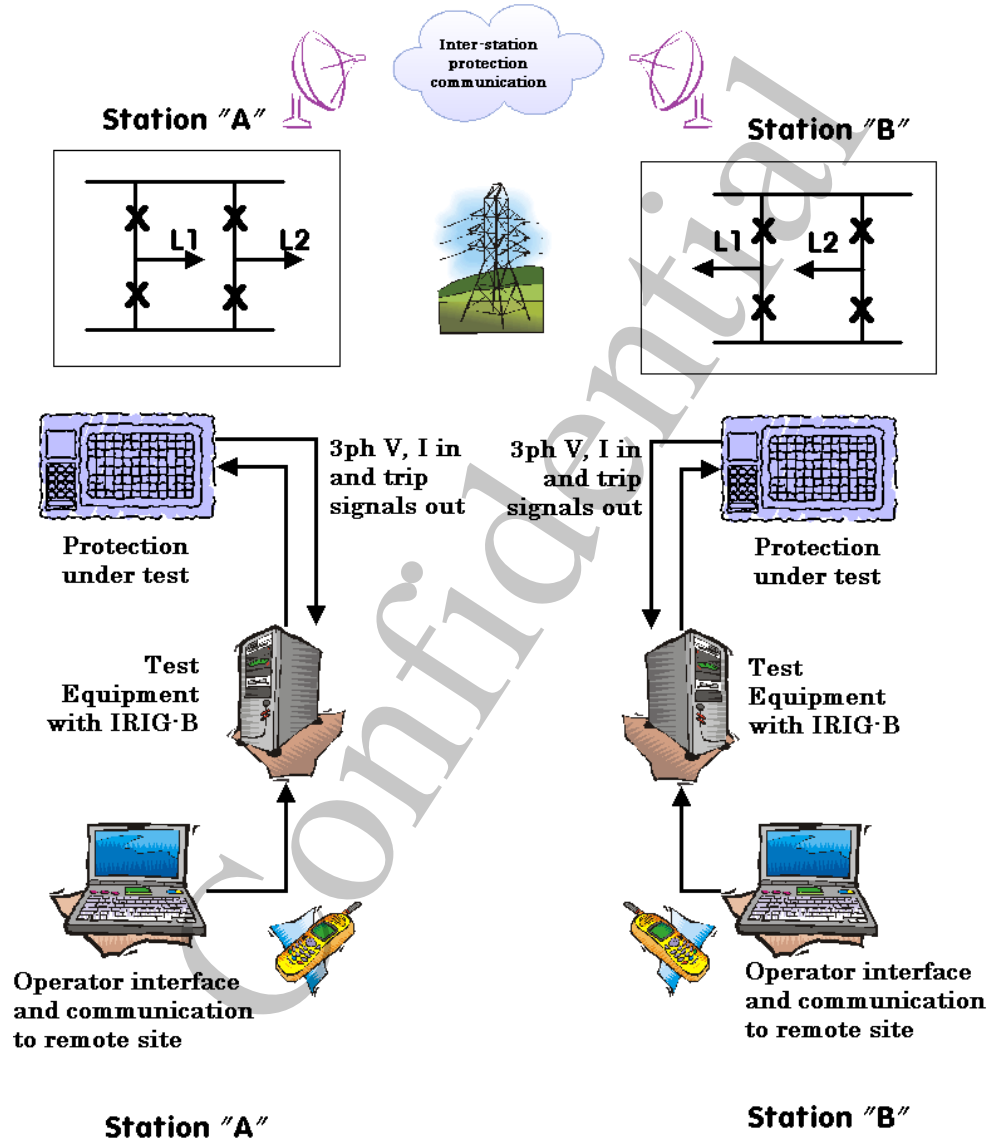

Figure 2—Example setup for transmission line end-to-end testing using GPS

## 4.6 Methods for generating test modules and cases

### 4.6.1 Fault studies

A test module comprises currents and voltages with/without external logic inputs (for example, digital signals for fault inception point or reclosing command) that need to be applied to a protection device or system. In order to generate test modules, specific fault studies need to be conducted and analyzed. One has to make sure that a specific test set can handle these quantities. Otherwise, some compromise or adjustment has to be made for accommodating the test set.

- In general, there are 11 types of faults: ABC, ABCG, ABG, BCG, CAG, AB, BC, CA, AG, BG, and CG. However, there are variations in the way these faults occur.
- Simultaneous faults (unusual). There can be simultaneous faults of two types mentioned above at the same or different location. For example, BC and AG fault at the same time. Or AG and BG demonstrate fault resistances at the same time. Also, a conductor can break and fault to ground, causing open phase with line-to-ground fault.
- Sequential faults (unusual). There can be more than one fault in power system, particularly during bad weather conditions. This will test relays that can experience external faults or external faults followed by an internal fault.
- Intercircuit/cross-country faults. A fault can occur between two lines operating at same voltages (intercircuit) or different voltages (cross-country) but located on the same tower. For example, phase A of a 230 KV line can be faulted to phase B of another 230 KV or 69 KV circuit on the same tower or sharing the same right of way.
- Evolving faults. A fault may start with one phase and evolve into other phases within a time period. Here, the speed of the relay may be slower because of phase-selection logic. For example, the fault can start with AG for one cycle followed by AB or ABG for three cycles.
- Fault locations. When deriving the test currents and voltages from fault studies, faults should be created on the line at different points. Usually, a close-in fault, middle of the line, end of the line, and in the reverse direction close to the bus will be adequate. If there are parallel lines, a fault on the parallel line should be created to see the effect of zero sequence mutual coupling. When applicable, the effect of sequential clearing on the adjacent line is tested.
- Fault duration. Fault duration can be anywhere between 0.5 cycles and a few seconds to test various aspects of a protective systems logic. A self-clearing fault may last 0.5 to 1 cycle.
- Faults through reclosing cycles. This is an extension of fault duration. Here, the fault currents and voltages may change after reclosing. If it is high-speed reclosing from both ends, the fault current reversal can occur within a cycle or more that can be experienced by a parallel line as an external fault.
- Varying fault impedance helps determine protection sensitivity, phase selection, and time coordination.
- Varying fault inception angles. For example, simulating different fault types with 15° or 30° intervals helps verify protection performance under various dc offset conditions.

#### 4.6.2 Fault data assembly

Compilation of fault data usually consists of gathering the prefault, fault, and postfault quantities. Three-phase voltages are needed. Depending on the type of test, single or three-phase currents may be needed.

- *Prefault.* Prior to a fault, the line can be loaded between minimum and maximum. If the fault is sequential, i.e., an external fault with a subsequent internal fault, then prefault can be external fault quantity. The prefault time can be set from a few cycles to many seconds.
- *Fault.* Fault quantities that are derived from fault studies or selected may last for three cycles to a few seconds, which should be determined by the user.
- *Lines with automatic reclosing.* For lines with automatic reclosing, two sets of fault quantities may be needed to simulate reclosing interval. One set is for the initial fault, followed by dead time/band (open breaker) before reclosing with another set of test quantities. For external fault simulations adjacent to the line position under test, the impact of automatic reclosing on the adjacent line should be considered as part of the test. For example, changes in line loading characteristics after the initial fault may need to be considered as part of the automatic reclosing. Other examples include voltage and current oscillations after the initial fault.

#### 4.6.3 Transient simulation

Protection systems or relays are exposed to transient currents and voltages in various circumstances as pointed out below. This transient situation can best be simulated using time-domain simulation programs described more in depth in later sections of this guide. The outputs from these programs can be downloaded to an active test set that can be activated for testing. Transient simulation tools assist in preparing test cases that may include the following:

- *DC offset.* The fault current may include dc offset, based on factors such as  $X/R$  ratio and point-on-wave incidence. The dc offset may have influence on the performance of a relay. The relay can overreach/underreach unless the relay filters the dc. The speed of the relay may be affected, too. The offset current can be simulated by transient simulation programs.
- *Power swing simulations.*
- *CT saturation modeling.* A heavy fault current or presence of dc offset current can saturate a CT, causing a distorted secondary current waveform. Relay performance can be degraded due to this distorted waveform.
- *CCVT subsidence transients and high-frequency ring behavior.* A CCVT contains capacitors, inductors, and a voltage transformer. Any change in power system voltage results in transient energy adjustment within these components that causes nonfundamental frequency to appear in the voltage waveforms, which affects the performance of equipment.
- *Subsynchronous fault current.* A subsynchronous fault current can occur in a power system having series compensation. This subsynchronous current can degrade the performance of the distance function.
- *Line energization.* Line energization transients can contain harmonic currents and voltages. For long lines, sometimes line reactors are used to control the voltages. Line capacitance and reactor impedance can produce resonant currents. Relays can be affected by these harmonic transients, which may last for few to several seconds.
- *Transformer (local and remote end) energization.* Sometimes, a transformer is part of a line zone of protection. This transformer can be energized by a breaker or a disconnect switch. During transformer energization, current containing harmonics can last many seconds. Because of the saturation effect of the transformer, harmonic resonance can occur. Relays can be affected by these transient currents and voltages.

- *Voltage source location (i.e., CCVT).* Location of voltage source has impact on distance measuring elements, for example, on series compensated lines.
- *Fault location and characteristics.* Variations in fault location and characteristics such as incipient angles, fault impedance, and so on, have an impact on the performance of the protective device.
- *Current differential protection.*

#### 4.6.4 Power swing abnormal conditions

Transmission line relays are designed with “out-of-step” (OOS) elements (i.e., out-of-step tripping or power swing blocking) by measuring the impedance locus. Examples include time delay between two impedance characteristics, one encompassing the other. The applied voltage, current, and phase angle can be manipulated in a dynamic test simulator to move the impedance trajectory from the outside characteristic to inside characteristic beyond a set time. This method is generally used for blocking function. Similarly, tripping functions are designed by moving the trajectory from outside to inside to outside within a time frame.

It has been observed by some power system engineers that the traditional testing methods for microprocessor distance elements may not work on OOS elements, considering that out-of-step swings are three-phase phenomena and are more slow-moving and gradual than faults. As with other protective elements, it is crucial that the functions are adequately tested prior to placing them in-service.

It should be noted that it is generally inaccurate to test OOS elements by examining the results of the stability program and the R-X impedance swing locus, picking out several states of a swing condition and playing those states through the relay, trying to make the transition as smooth as possible. The reason is the step change between states does not accurately reflect the actual impedance transitions the relay will experience. Figure 3 illustrates stable and unstable swings as generated by a transient stability program, using 0.25 cycle steps, superimposed on line protection and out-of-step characteristics.

It has been proven that it is possible to take the raw positive-sequence voltage and R-X output from a dynamic stability program (using power system load flow modeling), calculate balanced three-phase quantities for each time step, and then translate this data into COMTRADE waveforms that can then be imported into modern relay test software that can play the waveforms through a relay. Figure 4 and Figure 5 illustrate an impedance trajectory generated by a stability program and the resulting COMTRADE waveforms in a relay testing program.

One challenge for out-of-step relays is the case of a fault that occurs during a power swing when the distance function has been already blocked. Again, the testing of these functions requires a simulation as close as possible to the real system conditions and at the same time needs to take into consideration the capabilities of the test equipment. Because testing tools normally generate the simulated current and voltage signals based on built-in modules or replay of COMTRADE files, it is clear that the following two approaches are possible: 1) use of a testing tool designed to simulate power swing conditions (synchronous or asynchronous) and faults that occur during a power swing, and 2) play COMTRADE files for power swing conditions (synchronous or asynchronous) and faults that occur during a power swing. Such files can be generated using off-the-shelf transient simulation programs or can be produced from disturbance recorders capturing real events.

Figure 6 and Figure 7 show an asynchronous power swing and asynchronous power swing with a single phase to ground fault that can be used for testing the power swing blocking function of distance relays.

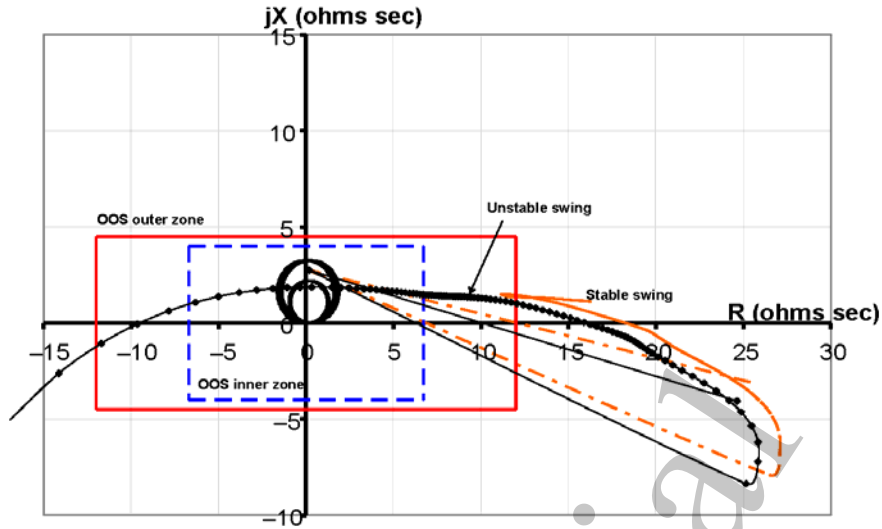

Figure 3—OOS impedance trajectory from dynamic simulation using transient stability program

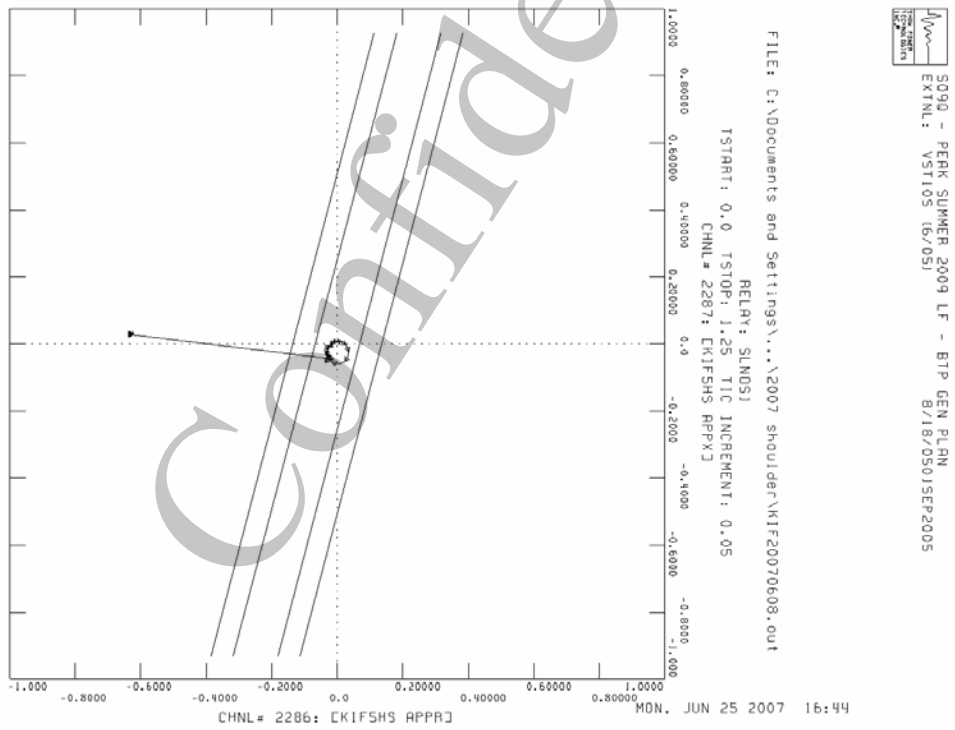

Figure 4—OOS impedance trajectory from dynamic simulation using transient stability program

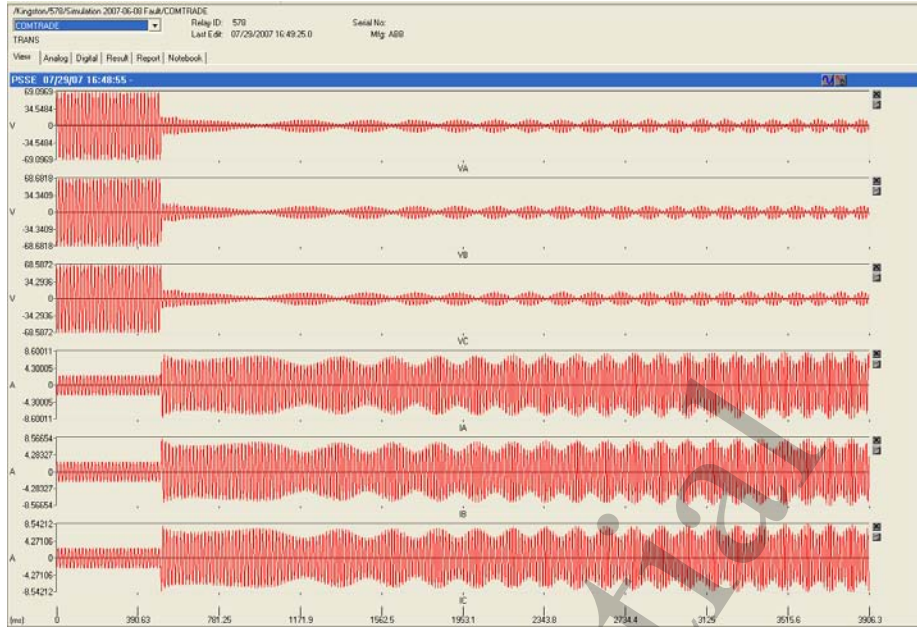

Figure 5—Resulting three-phase voltages and currents

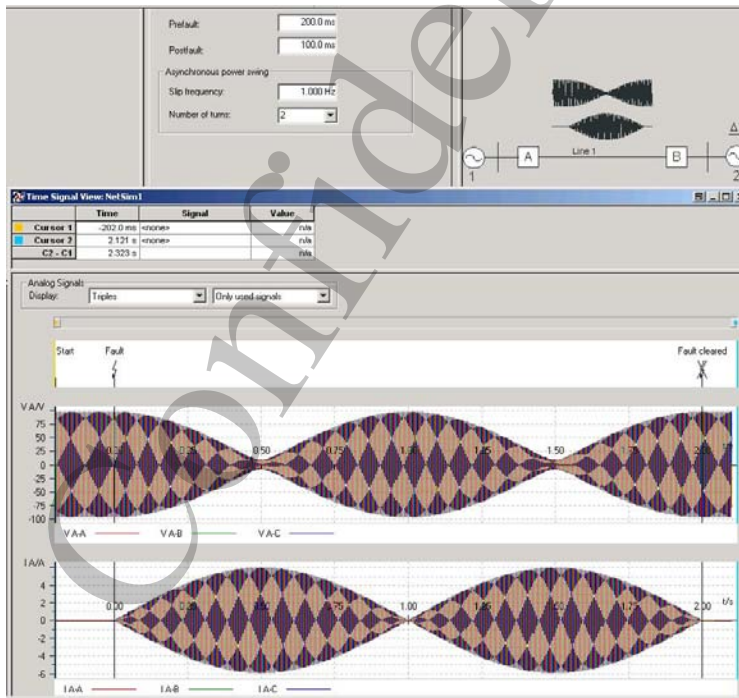
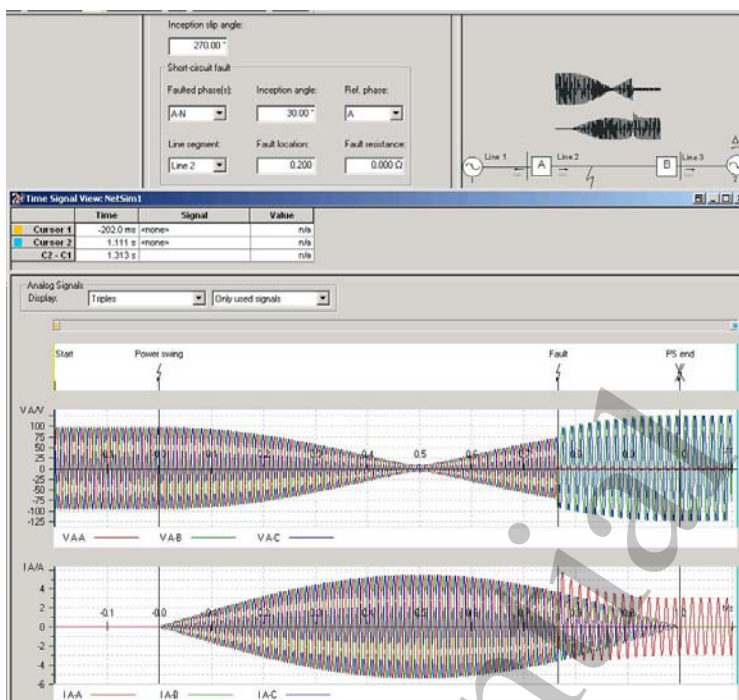

Figure 6—Asynchronous power swing simulation





**Figure 7—Asynchronous power swing with single-phase-to-ground fault simulation**

#### 4.6.5 Real-time simulation for transmission line relay performance evaluation

Power system simulations for relay performance evaluations are often conducted by users as well as by manufacturers to verify the performance of a newly developed relaying system or to verify the performance of an existing product in some special situations. Real-time simulation testing is covered in detail in the line protection section.

Power system simulation has been used for the relay performance evaluation for many years. The simulation tool should be easy to configure, should be able to simulate all power system contingencies, and provide means to analyze test cases automatically. The simulator should operate in a closed-loop mode with relays tripping and reclosing circuit breakers within the simulator. Performance evaluation of relays may take anywhere between 2 days and 2 weeks in most applications, depending on the complexity of the relaying system. Simulation tools such as real-time simulators can also provide means for testing of back-up elements, sympathy trips, voltage collapse, and other slow events that require interactive testing.

#### 4.7 Analyses and retention of test results

The goal of analyzing test results is to determine the performance of relay systems. This analysis may determine whether the scheme operated correctly or whether the scheme has any subtle and/or noncritical problems. It may help establish a historical reference that will help in determining degradation of the system over time, and the analysis can even help determine component failure.

Systems are tested initially from the component level to the overall system. For example, a line relaying system may have each individual relay tested for specific calibration, but fault simulation tests will be applied at all terminals of the line to determine how the entire line relaying system functions. Frequently, routine testing no longer involves component testing and will consist of an overall system test. Component testing is only performed during initial commissioning of a system or after major or significant changes.

Requirements for retention of test results may include pretest and posttest records. For example, a description of what is needed for testing is as follows:

- Description of concept
- Verification of firmware and software versions
- Setting calculations
- Apparatus engineering datasheets
- Procedure to perform tests
- Set points
- Test block diagram
- Required test equipment with tolerances
- Schematics

The requirements for the analysis and the pass/no pass criteria for each test are also identified. For example, test equipment tolerances and correction factors and how they are incorporated into pass/no pass checks may be described.

This subclause provides a description of test result analysis and how the findings are archived.

#### 4.7.1 Certification tests

Certification tests are performed to verify that a relay system or scheme is performing according to its design. Relay systems/schemes are usually made up of devices from various manufactures; therefore, certification tests at the factory are important because they provide a modeled, controlled environment similar to that found in “real life.” Models prepared to perform certification tests include circuit breakers and other equipment or functions found in the substation. Certification tests are made up of the following:

- Technological conformance tests
- Functional conformance tests
- Functional performance tests

Technological and functional conformance tests are generally type tests made by the manufacturer to validate the design of the microprocessor-based device, and consequently in most cases, there is no need to repeat them for a specific, customized system or scheme (Table 1).

Functional performance tests are commonly performed on mockup assemblies located in a laboratory under a controlled environment. These mockups, which are made up of relays, microprocessor-based devices, and supplementary apparatus such as model circuit breakers, shall provide the same functionality of the real application. Some components of the real systems need to be simulated like breaker status and operation. The laboratory environment allows all aspects of the system to be monitored, and the final result of the testing is that the user will have a high degree of confidence in the functionality of the systems.

SIPS, which are also referred as special protection schemes (SPSs) or remedial action schemes (RASs), are some examples of a protection system that usually require certification tests (proof of concept) prior to implementation. SIPS may involve analog and status data from sources at many remote locations and perform actions at many different sites. A SIPS may have significant impact to the stability of the electric system, where the initiating events can be the loss of a transmission line, generator, frequency excursions, and other losses of equipment. It is not practical or prudent to perform certification tests in the field on the actual electric system. The details of the SIPS may be verified with mockups/proof of concept under controlled situations. The owner of the SIPS will only test the actual SIPS under verified specific

conditions, and even then the SIPS may have to be tested in subsets of the entire system. For example, if a SIPS involves load tripping at multiple substations, system testing may be accomplished with overlapping concepts and predetermined blocks of load based on the SIPS application.

**Table 1—Types of certification tests**

Test	Analysis/verification	Retention
Technological conformance tests (for each individual device)	Verifies the response of the device to the environment (physical, electrical, electromagnetic, mechanical) according to the IEEE or IEC standards and to own design of the device. Usually the manufacturer provides type test certificates and no need to repeat.	Type test reports to keep in files
Functional conformance tests	Verifies the response of the different protections and control functions implemented in the microprocessor-based devices to IEEE or IEC standard and/or the manufacturer own specifications. Typically these tests are performed using a pure sinusoidal 60 Hz input. Usually, the manufacturer provides type test certificates and there is no need to repeat.	Type test reports to keep in files

#### 4.7.2 Application test

Application tests are specific tests to determine the suitability of a relay for a specific protection system design. Application tests are based on a detailed model of the power system and include performance testing against a wide variety of possible system disturbances or fault conditions. The model, the simulation case results in COMTRADE format or real-time digital simulation, special cases such as current reversal for a line protection, or a high-impedance fault are commonly retained as part of the protection system performance evaluations. Different types of application test records include relay targets, oscillography, fault location, event records, pilot channel performance, breaker failure and reclosing, and so on. The test results may be reported from a variety of sources such as test equipment software, independent fault recorders and station sequence of event recorders, and microprocessor protective devices.

Results from the application tests can be used in a variety of ways, such as for collaborations with a respective product manufacturer's feature enhancement and standard scheme installations. Application test results retention is equally important for interconnected power systems. As power system conditions change, these records could be used for further system evaluation and set point verification.

#### 4.7.3 Commissioning tests

Commissioning tests are performed on equipment installed in the field to verify the proper functionality of relaying systems. These tests are usually products of the certification tests performed in the laboratory and generally do not involve component testing. These tests may involve tests of the entire system (Table 2).

**Table 2—Samples of functional testing as part of commissioning**

Test	Analysis/verification	Retention
Scheme checks	Relay input and output contacts work properly. Cut-off blades and test switch function properly. Breakers can be operated by supervisory, local, and relay contacts. Relay pushbuttons for enabling of functions (reclosing, cold load, local control) work properly. Alarm conditions are simulated to check proper indication in the sequential event recording device.	The relay technician performs these tests, fixing any problems found, and documents any changes on the prints and in the configurations as applicable.
Fault simulations	Verify instantaneous tripping for all types of internal faults (a communications-assisted trip scheme). Selected 3L, LL, SLG, 2LG faults located at 10%, 50%, and 90% along the line are simulated at both ends using satellite-	Check-off of written procedure by the test engineer. Fault reports and event recorders

	synchronized end-to-end tests. Verify restraint for all external faults (reverse element of distance relay restrains either end from tripping). Verify time-delayed backup tripping.	generated by the relays are saved. Sequential event records are retained as applicable.
In-service tests	Phasing is correct into relays and meters.	Phase reads are recorded and sent to the Maintenance Division for storage. Metering snapshots are taken and documented.

#### 4.7.4 Periodic maintenance tests

Periodic maintenance testing is used to verify the proper functionality and reliability of protection systems. The information gathered from periodic testing can be used to establish a history of relay performance. Periodic testing is usually performed on a component basis such as protective relays or transducers to verify proper calibration and operation. The interval of these tests is usually determined by each owner's Relay Maintenance Program and often takes into account owner preferences. The protection systems can be configured with individual electromechanical or solid state components, which may not have self-monitoring, or can be made of microprocessor-based type with self-monitoring and alarming capability, where performance and availability are fully monitored at all times. In some cases, a regulatory agency may require a more rigorous process for demonstrating with sufficient levels of documentation their maintenance practices and records, as described in the Regulatory Considerations section. The periodic maintenance programs have established testing intervals with tracking and archival of test results. (See Table 3 below for an example of relay testing intervals.)

**Table 3—Example of relay testing intervals**

Relay voltage (kV)	Maintenance interval (years)
500	2
230	4
115	4
69	4
Less than 69	4

Periodic system testing is becoming more popular. Table 4 indicates a typical example of a test performed on line relaying systems.

**Table 4—Example test plan for line relaying systems**

Test	Analysis/verification	Retention
Fault simulations	Verify relays call for instantaneous tripping for all types of internal faults (a communications-assisted trip scheme). Selected 3L, LL, SLG, and 2LG faults 10%, 50%, and 90% along the line are simulated at both ends using satellite-synchronized end-to-end tests. Verify restraint for all external faults (reverse element of distance relay restrains either end from tripping). Verify time-delayed backup tripping.	Compare all test results (fault reports, sequence of events records) to previous year's results.

#### 4.7.5 Testing after a forced outage

This type of test is often performed after a loss of a significant element of the electric system or after a suspected incorrect operation of a relay system. During a disturbance in the electric system, relays are expected to operate correctly to isolate the affected equipment. If the protection system performs properly, then damage will be minimized. When the disturbance compromises a significant corridor, load center, or generation, it may be necessary to analyze the results to determine the proper operation of all protection

systems. When the detailed evaluation of the protection records demonstrates satisfactory scheme performance, the operation of the relay system may be considered as a substitute for scheduled periodic maintenance testing.

If a disturbance of the electric system results in a suspected operation of a protective relaying system, then testing will be required. The test results can be compared with archived data to identify the failure. This failure may be a component, a relay setting, or even the overall logic, and the solution may require more certification tests.

Tests following apparent incorrect operations:

The steps for these kinds of tests are as follows:

- Analyze the original event to try to determine why the system operated incorrectly and compare the event to the last tests run on this system (commissioning or periodic maintenance test).
- Attempt to recreate the misoperation by simulating the initial event.
- Make the appropriate correction (wiring, relay settings, replacement of damaged components), resimulate the original event, and verify that it fixes the problem.

The information kept from disturbances includes the following:

- SCADA breaker operation record.
- SCADA event log.
- Power operations dispatcher log.
- Relay fault records, oscillography, and sequence of events record (SER) data.
- System diagram detailing system conditions at the time of the event.
- Fault report [also called the disturbance analysis report (DAR)].
- Final root-cause analysis report, which includes a summary of what corrective action was taken. This report becomes the official record of the event.

## 5. Benefits and justification for different types of tests

Traditionally, the protection and control system is designed to identify local fault events, such as a short circuit, based on the voltage, current, and frequency determined at a specific point on the utility system. The protection and control system is designed to prevent a wide area failure of the utility system by isolating these local events. Changes in the operation of the power system, in terms of location and operation of generation sources, transmission capacity, and load demand, as well as changes in power system equipment such as the growing availability of reliable wide area communications result in changes in some basic philosophies of the protection and control system. For example, wide area protection schemes and system integrity protection schemes are applied more frequently to prevent failure of the utility system during wide area events or to prevent local faults from cascading into wide area events. These types of schemes and the narrower safe operating margins of the utility system commonplace today make improperly controlled local fault events a rising danger and require the testing of the protection and control system as a system, not as only individual components.

The goal of testing the entire protection and control system is to validate the performance of the entire system, from the individual components to backup, redundant, and auxiliary components, and the interaction between these components work correctly in terms of maintaining the dependability and security of the scheme at a desirable level of performance. The benefit of testing individual components is known from years of experience: If the individual parts work and the scheme is designed and installed

correctly, there is a high probability the system will work correctly. However, protection system testing verifies that the scheme is correct in both concept and application settings. An example is end-to-end testing of transmission lines, using test conditions based on fault contingency studies. The different test cases, run simultaneously at each end of the line, confirm that all relays, communications equipment, and auxiliary equipment work for commonly anticipated events and worst-case scenarios. It is even possible to simulate typical modes of failure of the individual components to ensure the protection and control system will still identify and control fault events.

The key benefit to protection system testing includes verification of the protection and control scheme in its entirety. A proper test documents the performance of the protection and control system and limitations of performance. The test documentation also serves as a baseline for evaluating future performance during actual events versus the expected performance. Baseline performance is used to compare differences between expected and actual events. Testing the performance of the protection system, especially wide area protection schemes or system-integrity protection schemes, is dependent on static and dynamic system models. As these schemes and the system behavior during events the schemes are designed to protect are very complex, testing can provide the engineer a better understanding of the protection system, the limits of performance, and the possible modes of failure. One type of testing for system-integrity protection schemes is to install the system, while blocking any control actions, to analyze the performance of this protection system during actual system events. This actual test data can be used to improve the static and dynamic models of the power system. Another benefit is actually illustrating or understanding the protection and control system performance during certain types of events and where and why failures may occur. The importance of written test procedures and documentation are described in 4.7.

The design of the protection and control system requires careful consideration of the performance requirements for the specific location, analysis of power system behavior, and an understanding of the actual limits of performance of components available for use in this application. Testing for the protection and control system at a specific location should be performed to prove the assumptions made during the design phase, starting with the individual components and working toward testing total system performance.

## 6. Description of types of relay schemes and testing requirements

### 6.1 Introduction

Different types of tests identified in this guide are as follows:

- Certification
- Conformance
- Application
- Commissioning
- Maintenance (forced or periodic)
- Troubleshooting
- Application

This subclause presents guidelines pertaining to application, commissioning, and periodic maintenance tests for the purpose of scheme testing, throughput timing, and validation.

## 6.2 Line protection

### 6.2.1 Types of transmission line protection schemes

Relay protection schemes for transmission lines can be generalized into nonpilot and pilot protection schemes. The nonpilot relaying system is used on radial transmission lines or other lines where high-speed tripping is not required. It is also used in conjunction with a pilot relaying scheme as a backup line protection. The most commonly used relays in nonpilot schemes are phase and ground overcurrent and stepped distance relays. Refer to the normative references in IEEE Std C37.113<sup>TM</sup>-1999 [B26].

#### 6.2.1.1 Nonpilot protection schemes

##### 6.2.1.1.1 Overcurrent relaying

An overcurrent relay is a simple relaying device that requires only one input variable (current) in sensing and measuring fault currents. The basic function of the relay is to operate or pick up when the detected current exceeds a predetermined value or level. Overcurrent relays are applied separately in phase and ground fault protections. The phase overcurrent relay senses phase-to-phase and three-phase faults while the ground overcurrent relay senses any phase-to-ground or multiphase-to-ground fault. A complete set of overcurrent protection would require three phase-overcurrent relays and one ground-overcurrent relay.

The operating time characteristic of overcurrent relays can be instantaneous or time delayed. Instantaneous overcurrent relays operate with no intentional time delay when the measured current exceeds the set level. Time-delay overcurrent relays can have fixed or inverse time delays. The inverse time-overcurrent relays have operating times that vary inversely with the magnitude of fault current.

Overcurrent relays are inherently nondirectional. However, by providing some polarizing quantity such as voltage, overcurrent relays can be directionally supervised. For ground directional supervision, for example, the zero sequence voltage may be used to establish the potential polarization or directional reference. Another method of obtaining directionality is to use the neutral current of a wye-grounded/delta power transformer. The polarizing technique will depend on the type of device or setting elements appropriate to the application.

##### 6.2.1.1.2 Distance relaying

Distance relaying is the most widely used type of transmission line protection scheme. It offers several advantages with respect to overcurrent relaying such as higher speed, simpler coordination, lesser influence by system changes and power swings, and permitting higher line loadings. Distance relays are designed to respond to the current, the voltage, and the phase angle between the current and voltage. The relay measures the ratio of voltage to the current or the impedance of the line section to the fault and of the fault. The impedance measurement approach provides an excellent way of discriminating faults from normal conditions. The discrimination is obtained by limiting relay operation to certain ranges of impedance or zones of protection. Typically, the first zone of protection (zone 1) covers 80% to 90% of the line. A fault located in this zone operates the relay instantaneously. The second zone of protection typically overreaches the line coverage by 10% to 20%. The relay can be set with a time delay, typically, 20 cycles, for the relay to operate in zone 2. The third zone may be set to cover beyond 200% of the line. Relay tripping in the third zone is set at higher time delay than that of the second zone. These protection zones are set as stepped distances or ranges of impedance. Zones 2 and 3 protection time delay provides remote backup to local relays.

The stepped zones of protection provide distance relays with enhanced selectivity and improved coordination. However, the major disadvantage of straight distance relaying scheme is that high-speed

tripping of breakers at both terminals can only be achieved if the fault is located within zone 1 of both distance relays. If the fault occurs beyond the zone 1 of one of the relays, then tripping of associated circuit breaker(s) is achieved with the zone 2 time delay. Hence, the straight distance scheme is not applicable on transmission lines where high-speed reclosing is applied to maintain system stability. In this particular application, the only solution is some form of pilot relaying.

### **6.2.1.2 Pilot protection schemes**

The pilot relaying scheme is generally used in HV and EHV transmission lines. The term “pilot” refers to the use of communication paths or channels to send signals between the protective relays. Pilot relaying schemes are inherently selective with the primary purpose of providing simultaneous high-speed tripping of all circuit breakers in the protection system for any kind of fault. However, pilot protection schemes are more complex primarily because of the requirement for highly coordinated relaying functions and communications.

The pilot protection schemes that are commonly used for line protection are pilot distance and line differential schemes. The pilot distance relaying schemes normally involve the use of distance relays. In some pilot schemes, ground directional overcurrent relays are used instead of ground distance. The widely used pilot distance relaying schemes are directional comparison blocking and unblocking, permissive overreaching and underreaching transfer tripping, and direct underreaching transfer tripping. In line differential schemes, the most commonly used schemes are phase comparison and current differential relaying.

#### **6.2.1.2.1 Directional comparison blocking and unblocking schemes**

The directional comparison blocking (DCB) scheme using a power-line carrier is widely used. The versatility and flexibility of the scheme makes it most applicable in multiterminal lines. By sensing the direction of the fault current at a given terminal and by sending information to the remote end and applying appropriate logic, the relays at each terminal can determine whether the fault is internal or external to the zone of protection. For external faults, the fault current flows in the same direction at the terminals. The relay at the terminal closest to the fault sends a blocking signal to other terminals to block tripping. When the fault is internal, all fault currents at the terminals flow toward the fault. The relays at each terminal detect the fault currents but do not receive any blocking signal. Hence, simultaneous high-speed tripping is permitted. The system employs an “ON-OFF” power-line carrier channel, distance relays for phase fault detectors, and directional instantaneous overcurrent relays for ground fault detector. The channel signal is initiated by the phase distance and ground overcurrent units known as carrier start relays.

The directional comparison unblocking pilot relaying scheme uses frequency-shift keying (FSK) power-line carrier channels. There are two communication modes in the form of frequency shifts: block and unblock signals. The block signal is continuously transmitted between terminals, thus eliminating the need for carrier start relays. For internal faults, the carrier signal is dropped and the unblock signal is keyed, thereby permitting simultaneous high-speed tripping at all terminals. Unlike the “ON-OFF” channel in the blocking scheme, the integrity of the FSK communication channel can be monitored, which is important to prove that the loss of carrier for block signal will not result in false tripping.

#### **6.2.1.2.2 Direct underreaching transfer trip scheme**

In transfer trip schemes, the communication channels are generally via a microwave or fiber-optic medium or a hybrid microwave and fiber-optic medium. Because the communication system is separate from the power system, the scheme offers certain advantages. The channel time can be shorter, in the range of subcycles, and different types of signaling such as tone and digital mirrored bits can be implemented.



In the direct underreaching transfer trip (DUTT) scheme, directional distance relays are used at the terminals. The relays are set for underreaching (zone 1) and overreaching (zone 2 or 3) relaying. If the fault occurs within the zone 1 of both relays, the relays trip their local circuit breakers instantaneously and, at the same time, send direct transfer trip signals to the remote ends. At the receiving end, the received transfer trip signal directly trips the circuit breaker(s) without supervision. When only one underreaching relay sees the fault, it is the only one that sends the direct transfer trip to the remote end and instantaneously trips the remote circuit breaker(s). In the event the remote end fails to receive the transfer trip signal, its circuit breaker(s) will trip after the zone 2 relay times out.

#### **6.2.1.2.3 Permissive overreaching transfer trip scheme**

The shortfall of DUTT in security can be resolved by the use of the permissive overreaching transfer trip (POTT) scheme. In this scheme, the transmission of the permissive transfer trip signal is initiated by the overreaching relaying elements (zone 2 or 3). For any internal fault, the distance relays at both ends receive permissive transfer trip signals. The received POTT signal is logically coupled with fault detection by the overreaching relay element to trip the local circuit breaker(s). Should one of these logic inputs be absent, the breaker tripping does not occur. The overreaching relaying elements also provide time-delayed backup relaying. Because of the added security, POTT is a widely used transfer trip scheme.

#### **6.2.1.2.4 Permissive underreaching transfer trip scheme**

In the permissive underreaching transfer trip (PUTT) scheme, the distance relays at the terminals are set with underreaching and overreaching relaying elements. For internal faults, the underreaching (zone 1) relay that detects the fault initiates or keys the transmission of transfer trip signal and instantaneously trips the local circuit breaker(s). At the receiving end, the overreaching (zone 2) fault detecting relay is logically coupled with the received PUTT signal to trip the circuit breaker(s) instantaneously. For a fault in the overlapping zone 1, both terminals trip their local breakers and send PUTT signals to the remote ends. This variation of permissive transfer trip scheme is also widely used.

#### **6.2.1.2.5 Phase comparison relaying scheme**

A phase comparison relaying scheme is a form of line differential relaying where the phase angles of currents measured at the terminals are compared. When an internal fault occurs, the currents at the terminals flow toward the fault. Since the currents are 180° out of phase (i.e., they are flowing in opposite direction), the relays instantaneously trip their respective circuit breakers. For external faults, the currents at the terminals flow in the same direction, and therefore, the circuit breakers are not tripped. Many phase comparison techniques are available for this scheme and any communication medium can be used.

#### **6.2.1.2.6 Line current differential scheme**

Line current differential relay (87L) is a type of protection where peer relays are sending and receiving current phasors or sampled data over a communications channel in order to detect faults on the protected transmission lines. Two or more (in case of multiterminal line) peer-to-peer relays are required to comprise a line protection system. The preparation for system testing requires a good understanding of the particular relay system operating principles and the various components associated with the current differential protection and its scheme.

The major advantage of this type of protection is that line current differential is a unit protection, providing fast and simultaneous fault clearing at all terminals of the protected line. Other advantages include the following: The operating principle of this protection is based on terminal current only, protection is not affected by swings, and it is very fast and sensitive. However, there are some disadvantages. This

protection is a heavily channel-dependent system. In a case of systems using digital communication, security and sensitivity may be affected by charging current and channel asymmetry, when transmit and receive propagation delays are not equal.

In addition, different variations of the relay system operating principles are important in system testing. Variations of the line current differential protection include alignment of phasors from all terminals, number of data packets transmitted per power cycle, availability of charging current compensation, differential principle (restrained or unrestrained) employed, phase segregated or mixed operating mode, and so on. Depending on the relays selected, application and testing might be slightly different.

The performance of the line current differential relays is dependent not only on the protection algorithms but also on the ability to handle communication channel impairments properly. Channel impairments affecting line current differential relaying include communication noise, which can be continuous or bursts of noise; channel interrupts; channel jitter; variable channel delays due to switching on the higher order system; channel asymmetry; or an external loopback. The communication channel can be over direct fiber or over multiplexed channels on the synchronous optical network (SONET)/synchronous digital hierarchy (SDH) rings. Channels over direct fiber are considered more secure, but the cost is higher relative to the bandwidth utilization. In applications where channel redundancy has been applied, the relay system performance over both primary and alternative channels should be validated.

Most of the communications-related testing could be done in the laboratory during relay evaluation testing and by using special equipment to reproduce the channel impairments. Refer to IEC 60834-1-1999 [B11] for more information.

The protective relay capability and user selectable features used, operating principle, and the relay system set points will determine the extent of system testing. When channel redundancy is applied, it is critical that each channel is fully and independently tested.

For field commission testing, both external monitoring and/or, in the case of more modern relays, the relay monitoring tools can be used in order to prove the integrity of the communications channel. The performance of the line current differential relays can be quantized by the following categories:

- Dependability: the probability of not having a failure to trip operation.
- Fault clearing time: time interval between fault inception and issuing a trip command to open breakers.
- Security: the probability of not having an unwanted operation.
- Channel impairments handling: ability to handle properly channel noise, channel interrupts, channel switching, channel asymmetry, channel loopback, and so on without sacrificing security and dependability.
- Accuracy of differential restraint characteristics: includes both static and dynamic testing.
- Ability to handle line charging current and accuracy of charging current compensation if any.
- Ability to handle properly stub bus configuration when one of the line terminals is taken out of service by the opening of the line disconnect switch while other terminals remain in service.
- Ability to send and receive a direct transfer trip (DTT) signal properly for any possible topology of the protection system and protected line.
- Ability to detect faults on line energization and limits to detect high-resistive faults.
- Ability to handle properly outfeed and infeed fault current conditions and operate correctly at any fault inception angle during external and internal faults.
- Ability to handle properly line energization and switching of series and shunt compensation.

Similar to many protection systems, line load testing is an important test prior to placing line current differential protection in service, as secondary injection cannot validate that CT polarity or ratio. Also, secondary injection testing cannot reproduce natural line distributed capacitance or shunt reactors inductance.

Taking the aforementioned into account, further details on the follow-up commissioning and periodic maintenance can be found in Annex B.

#### 6.2.1.2.7 Direct transfer trip

The DTT is used to transfer a tripping signal from a protective device to a circuit breaker located at a remote area. This may be necessary for several reasons, including:

- Absence of a circuit breaker at the local station such as line terminated with a transformer without a circuit breaker at the high-side side of the transformer.
- Sending DTT as a result of bus protection operation or a breaker failure at the local station to ensure high-speed interruption of the fault current supplied from all remote sources.
- For a backup, to prove that remote terminal is open for a system fault.

The term “DTT” can be divided into the following categories:

- *Equipment transfer trip*—when the tripping signal is initiated from station protection such as bus protection, transformer protection, or as a result of a breaker failure.
- *Line transfer trip*—when line protection at one terminal detects the fault and sends DTT to either accelerate protection operation at the remote end, such as DUTT, or as a backup in case of the line current differential described above.

In the case of line differential protection, the equipment transfer trip and line transfer trip can be combined together over the current differential channel. This means that DTT can be initiated from either 87L operation (sometimes referred as internal DTT) or from external breaker failure or bus protection relay (referred as external DTT). However, it is desirable to have a clear distinction by the receiving DTT relay of what initiated DTT in order to block reclosure in case of external DTT.

#### 6.2.1.2.8 Automatic reclosing schemes

Automatic reclosing is a control scheme for quick reclosing of circuit breakers of a transmission line after clearing a fault. The application of automatic reclosing scheme is generally required to maintain system stability. For the scheme to succeed, sufficient outage time must be allowed for the fault path to deionize before reclosing. The deionizing time is dependent on the system voltage, but it normally takes place between 10 and 30 cycles.

#### 6.2.2 Transmission-line relay testing

Throughout the life cycle of a relay, the relay is subjected to a certification or factory acceptance test, application test, commissioning test, and preventive maintenance test.

### 6.2.2.1 Certification test

Certification tests may be conducted in the relay supplier factory or at another independent facility to verify the performance of the relay against established parameters and specifications.

### 6.2.2.2 Application test

The application test typically involves bench testing of the relay to confirm that its elements are in working order for a given application before the relay gets installed at a substation. Relay schemes and logic can also be tested in the laboratory prior to field implementation.

Transient tests using digital simulators have been developed mainly to emulate the traditional model power system concept in order to evaluate protective relay response to power system transients. Nonpilot as well as communication-based transmission-line relaying schemes (i.e., current differential, DCB, etc.) can be tested in a laboratory by injecting simulated voltage and current waveforms into relays under test. Relay input signals are generally derived from transient simulation software tools. Transient simulation techniques provide also tools for evaluating the overall performance of protective relaying schemes because they assist in testing the hardware, relay algorithms, settings, configuration, speed of operation, and transient performance of the scheme.

Transmission-line relay evaluation is based on line topology and length—short-line, medium-line, and long-line models. All three transmission-line models may have similar topology and may consist of parallel lines to introduce mutual coupling between them. Simulation of a strong source at one end with a relatively weak source at the remote end will assist in comparing relay performance under different conditions. Relays are required to be tested for internal and external faults during a maximum power flow situation. Faults at different inception angles will demonstrate relay performance under different dc offset conditions. Likewise, varying fault resistances will also validate relay response. Relays are also to be tested for evolving faults and current reversal conditions. It is desirable to evaluate relay performance under stressed conditions, such as CT saturation and CCVT transients.

Relays designed for the series-compensated line are often tested with system models incorporating a series-compensated line with the metal-oxide varistor (MOV) and bypass breaker. It is desirable to verify the performance of communication-dependent relay systems with degraded or corrupted communication networks. Some of the commonly practiced methods include the injection of noise in audio-tone communication systems or introduction of bit-error rates in digital communications networks.

Real-time or model power system testing provides a measure for evaluating the overall dependability and security of the scheme. In the case of transmission-line protection performance evaluation, these tests can be used to validate performance on heavily loaded long lines, series capacitors, and shunt reactors, especially for bulk transmission applications. Model power system testing is practiced where the response of the schemes cannot be evaluated analytically or by conventional test methods due to the complex interaction of various power system components during faults and the high-speed communications schemes required. In addition, model power testing provides a means of thoroughly investigating the transient performance of the relay system without subjecting the system to primary fault condition (such as stage tests).

Model testing also simplifies variations as follows:

- Fault location, type, and incidence angle
- Fault impedance.
- Source impedance magnitudes.
- Source impedance ratios;  $Z_1/Z_0$ ,  $X/R$ , etc.

- System configuration
- System hardware performance, stuck breaker, etc.
- System loading conditions

For the model testing, the power system parameters, as viewed from the relay terminals, should be as close a representation of the actual system as practicable. Some components needed for model power testing are as follows:

- a) Source impedance: positive, negative, and zero sequences. Different system conditions can be set up, for example, normal system and unusual configurations for weak feed scenarios if applicable.
- b) Line impedances: series and shunt; positive and zero sequences.
- c) Distributed parameters for long lines.
- d) Series capacitors: location, reactance, gap flashing, and reinsertion magnitudes and times; refer to IEEE Std C37.116™.
- e) Shunt reactors: location, reactance, and excitation characteristics.
- f) Mutual coupling between lines.
- g) Steady-state active and reactive power flows:
  - 1) Power circuit breaker dissymmetry. Breaker timing for each phase—if variances between phases (for tripping and for closing, respectively) are indicated by the manufacturer, the model may be set at maximum specified by the manufacturer.
  - 2) Power circuit breaker with stuck pole.
- h) Phase impedance dissymmetry:
  - 1) Untransposed lines.
  - 2) Unsymmetrical series capacitor gap flashing.
  - 3) One phase out of service in a three-phase bank of shunt reactors.

It is important that the instrument transformers used in the model have accuracy class such that the relay system burdens do not cause errors in the magnitudes or distortion of waveforms of the currents and voltages of the model during testing. This does not preclude changes to permit investigation of performance on saturated waveforms.

Transient simulation tools such as the Electromagnetic Transient Program (EMTP), the Alternative Transient Program (ATP), or the EMTDC allow the user to prepare relay signal playback via power amplifiers in automated fashion repeatedly and with varying system conditions (i.e., fault resistance, fault inception angle, etc.) if desired. Development of an adequate transient model is required to generate signals for different applications.

Operation of relay output contacts (trips, alarms, etc.) may be monitored and recorded by the simulator computer in order to help to evaluate relay response during simulation. Transient tests are sometimes referred to as dynamic or application tests. Figure 8 shows an example of an “open-loop” digital simulator configuration that can be used in the laboratory environment for testing communication-based transmission-line relaying schemes.

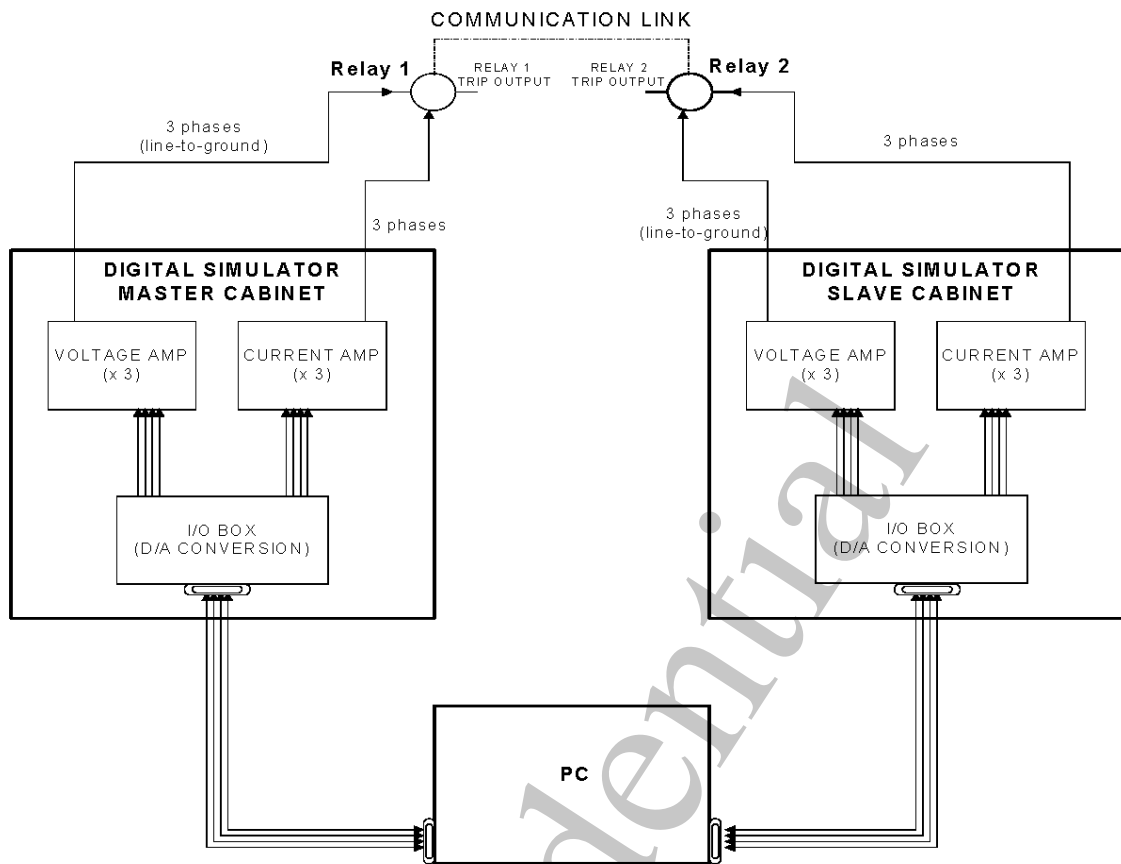

**Figure 8—Example of application test setup using “open-loop” digital simulator**

For more thorough or complete application tests, “closed-loop” digital simulators can be used. Closed-loop tests require transient model and power system simulation where output signals from the simulation are used as inputs to the relaying system under test. Relay outputs responding to these signals can then be fed back to the simulated power system, in turn changing the model configuration. This mechanism provides the means for testing both the relay system’s response to power system disturbances as well as the modeled power system’s response to the relay operation. Therefore, closed-loop tests can provide a realistic testing environment for a relaying system but require hardware to handle exchange of many input and output signals during a simulation. Closed-loop simulator software tools must also provide adequate means for accurate transient modeling, simulation control, and reporting results.

### 6.2.2.3 Commissioning test

The commissioning test involves the comprehensive testing of the transmission-line relay protection system. The relay protection system of a transmission line encompasses instrument transformers, wires and cables, relays, test switches, control switches, and communication equipment and channels. During the commissioning test, each device of the protection system is functionally tested. Currents and voltages are applied at the primary side of current transformers and voltage transformers, respectively, to verify proper ratio and phasing. The wires connecting the relays and other control devices are checked out end-to-end against schematic diagrams. Communication channels are separately tested for proper levels and frequencies. Relay tripping and alarm outputs are checked out, and tripping of power circuit breakers as well as proper alarm annunciation are proved. Finally, a system test of the protective relaying scheme is conducted.

#### **6.2.2.4 Preventive maintenance test**

This test involves periodic testing of a relay protection system of a transmission line. The test may not be as comprehensive as the commissioning test; however, it covers checking out all critical functions of the relays.

Steady-state tests are widely used for relay periodic maintenance and involve the use of current and voltage phasor injection to test individual relay operating characteristics and settings. Output contacts also need to be checked to verify they remain “healthy.”

### **6.2.3 Transmission-line relay protection system test**

#### **6.2.3.1 Staged fault test**

For many years, a staged fault test was used for comprehensive testing of a transmission-line relay protection system. It is considered the ultimate test because instrument transformers are covered in the test. However, conducting a staged fault test is costly, laborious, and inherently dangerous to personnel involved, and it puts the transmission system components under tremendous electrical stress.

The test involves generating an actual fault at a specified location within the line section or immediately out of the section. The responses of the protective relays at both ends and clearing times are then observed and noted. Associated alarms are checked out. Relays protecting adjacent transmission lines are also verified to ensure the relays do not trip on external faults.

#### **6.2.3.2 End-to-end testing by secondary injection method**

An alternative to staged fault testing of transmission-line relays is the GPS-synchronized secondary injection method. In this method, secondary currents, voltages, and their respective phase angles, simulating prefault, fault, and postfault conditions, are simultaneously injected into the line relays. The simultaneous injections of simulated events are synchronized by using GPS clock receivers. The secondary injection method only verifies the secondary circuits of instrument transformers; however, with the use of good fault data, it has become a reliable method for testing protective relaying schemes of transmission lines.

The technological advances of microprocessor-based relay test sets, portable computers, GPS clock receivers, breaker simulators, and application programs have made the dynamic-state testing of line relays possible. Under the simulated conditions, the relays at the line terminals are injected with currents and voltages in pure sine waves. These quantities are derived by conducting fault studies involving application of different types of faults at various locations of the transmission line. For example, the types of faults simulated include single-phase to ground, single-phase to ground fault with fault impedance, two-phase-to-ground, multiphase faults. Types of faults typically include internal faults (e.g., 10%, 50%, and 90% of line length from one terminal), external faults, and current reversals. All current and voltage quantities representing the prefault, simulated fault, and postfault conditions are compiled into test modules and downloaded into the test sets prior to the execution of the test.

Modern relay test sets are capable of generating transient waveforms that include dc offsets and harmonics. Transient fault data are more desirable in testing relaying schemes of series-compensated transmission lines. These data can be produced in COMTRADE files from playbacks of actual recorded faults by digital fault recorders (DFRs) if they are available and from fault studies using EMTP, ATP, or other similar tools. Transmission-line system modeling and running of EMTP or ATP application programs could take from 1 to 4 weeks. Modern programmable test sets generally support test modules composed of COMTRADE files.

A complete end-to-end relay test setup at each terminal is shown in Figure 9. A key component is the programmable relay test set. The test set is supported by computers, a GPS clock receiver, a circuit breaker simulator, and a SER or DFR. The SER may be an inherent function of the protective relay under test or may be implemented in an external device. One portable computer is used to control the relay test set and the ancillary devices while the other computer is used to control and monitor the relay being tested. The latest relay test set models may incorporate the GPS clock receiver, breaker simulation, and event recording functions. The tests are initiated by synchronizing signals at all line terminals.

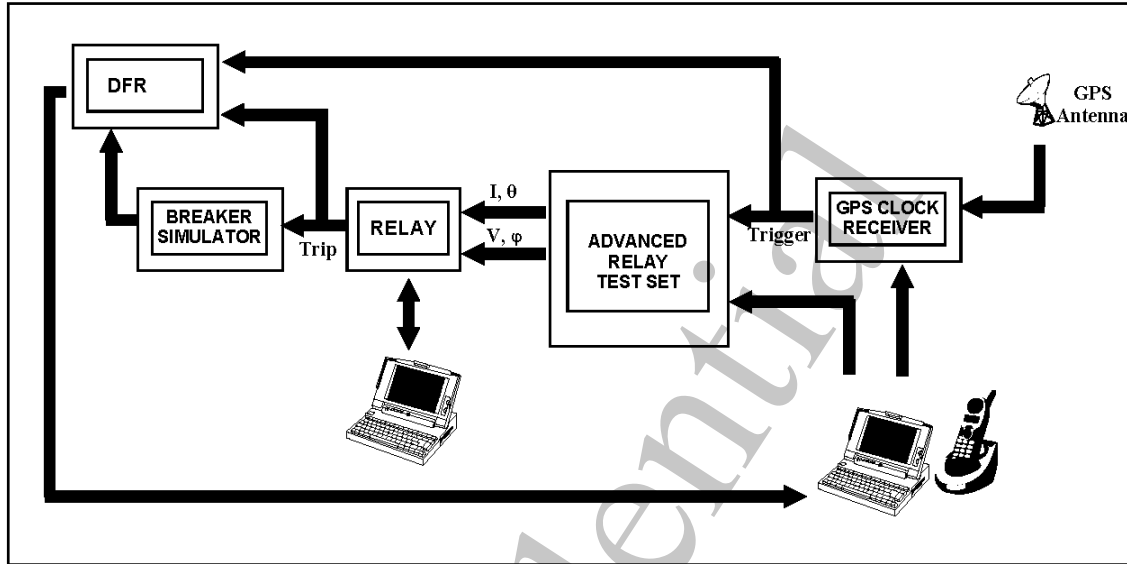

**Figure 9—Typical setup for end-to-end testing by secondary injection**

Test preparation involves the selection of types of faults (e.g., 1LG, 1L-G with fault impedance, L-L, and 3L-G faults) to be simulated and their locations that are internal and external to the protection zone. Additional faults may be required for special test applications (e.g., series compensated line). The line is first modeled using a commercially available fault study software program. A prefault condition is assumed, which is typically the normal loading condition of the line. Once the prefault data are established, an iterative process of running the fault study application takes place. For each predetermined internal and external fault, the preselected fault types are simulated. If necessary, the postfault condition is simulated and solved by running a load flow program. The fault data are then used in constructing the test file for the end-to-end relay protection system test.

In Figure 9, two computers are shown. The first computer hosts the automated software program for the relay test set, test files, and control applications for the auxiliary box devices. The second computer is used primarily to monitor the relay and to store relay fault data. A GPS antenna with flexible coaxial cable is installed for the GPS clock receiver. The antenna is run to the outside of the relay building and can be easily mounted on top of a parked vehicle or on any support structure or platform. In addition to setting up the test equipment, voice communication has to be established between terminals typically by telephone or radio. The relay technicians have to coordinate the time to trigger a fault in their respective relay test set.

In the second phase of the test, the test file is preloaded into the relay test set. The time agreed on is entered into the GPS clock receiver using the first computer. When the event trigger time arrives, the GPS clock receiver time stamps the sequence event recorder and triggers the relay test set to initiate the prefault injection into the relay. After a user-defined prefault interval, the relay test set automatically injects the fault quantities into the relay. When the relay trips, it opens the circuit breaker or triggers the circuit breaker simulator and sequence event recorder. For a complete end-to-end test where proper operation of circuit breaker and integrity of communication channel have to be verified, the circuit breaker simulator may not be used. Instead, the power circuit breaker is allowed to be tripped by the relay. The purpose of the breaker simulator is to minimize unnecessary circuit breaker operation. As different protective devices have



different operating principles, the prefault duration may be affected by the type of device under test. For example, some relays may need a longer initial condition in order to identify properly the normal system state after start of test versus a switch-on-to-fault event. Likewise, user-defined algorithms should be considered when setting up for simulation testing.

After the fault duration expires, the relay test set automatically injects the postfault quantities for a certain period and then terminates the injection. When reclosing is incorporated as part of the scheme control function, end-to-end tests may be set up to cover performance evaluation of the reclosing function. The second computer is used to monitor and evaluate the response of the relay. The test results displayed on the computer screen or printed out are immediately evaluated and compared with expected values.

The posttest phase involves more in-depth analysis of the test results, which is typically performed when the results do not meet expectations. This is a situation when protection engineers are involved in reviewing the fault study and in investigating causes of discrepancies. In this phase, the test results are documented and the reports are prepared when required.

It is common practice to use the same type and style of test equipment for all terminals when coordinating end-to-end testing to simplify troubleshooting and setup. However, using different types of test sets is possible. For example, different types of equipment may be used to test the protection system of a tie line between different power companies.

To synchronize the test equipment properly between different vintages or manufacturers, the factors influencing the response of the test sets should be addressed. For example, test equipment produced by different vendors may have different time delays after trigger. Therefore, the prefault time period may be different. To ensure that the triggering of fault injections is properly coordinated, the time delay after trigger of the relay test sets must be accurately measured and compensated for prior to the actual end-to-end test. The difference in time durations must be factored in the synchronization of secondary data injections.

It is important to note that the delay time after trigger may be different for state sequence playback and for DFR playback on each vendor. Refer to Annex E for additional information.

#### **6.2.4 Impact of high-impedance faults to protective relay performance and system testing**

High-impedance faults create certain challenges for line protection. The magnitude of the ground fault current on the given line is influenced by several factors: system neutral arrangement; fault arc resistance; fault ground path (return) resistance, which depends on the soil resistivity and tower footage ground impedance; extension of resistive zone caused by MOV action in series-compensated lines; and system equivalent impedances.

It is important to detect ground faults in order to minimize equipment damage and reduce system exposure. Undetected ground faults may lead to overvoltages and overheating of the equipment. This may evolve into phase-to-phase or three-phase faults carrying large fault currents and leading to a system stress.

The requirements and methods used to detect ground faults are different on solidly grounded, high- or low-impedance grounded, and ungrounded systems. Usually, single-line-to-ground (SLG) faults generate less ground fault current than other types of the faults, which means they are the most challenging for protection. Many of these faults are tree contacts, which can be of high impedance, particularly in the winter time when the soil is frozen. Refer to Annex C for more details.

## 6.3 Transformer protection

### 6.3.1 Transformer protection schemes

For transformer protection, several types of protective schemes are commonly applied, including current differential, time overcurrent, overexcitation, and sudden pressure. The transformer protective relay location and technology applied may also influence the type of protection design and testing. For example, consider a two-windings transformer when some level of protection for each high-voltage winding is located in the respective control building, and the buildings are large distances apart. Fiber optics may be used as a means of interface between protective devices in the different buildings to communicate decisions or information between the devices. There are also transformers that are part of a transmission line, and testing may involve communication equipment; see 6.3.4 for additional information. When redundant equipment of communication interfaces is designed, testing often is conducted with one complete system at a time.

### 6.3.2 Transformer differential protection testing

During commission testing, company personnel conduct visual inspections of the relays, wire connections, and design schematics. There are also several different current transformer tests performed in order to verify proper CT condition and connections. These tests are done when the transformer is out of service. By applying voltage and current, several tests are performed including ratio, polarity, and saturation. A Megger ground test is performed to check for undesired grounds.

Relay testing is done by applying settings and verifying the desired outcome. Typical tests include differential/slope, harmonic, minimum pickup, voltage protection, and sudden pressure. For the differential/slope test, two current sources are used to inject current into single-phase relays or three-phase relays with no vector compensation. It is suggested that for three-phase numerical transformer differential relays that have vector compensation settings, especially those that involve zero-sequence removal, three-phase current injection into both two relay windings be performed. The restraint coil is tested by applying a low mismatch current to see whether the restraint coil blocks the relay from tripping. A high-mismatch current is then applied to the operate coil to verify it trips the external devices. A harmonic test includes simulating a second and a fifth harmonic current to verify the relay(s) will not operate for overexcitation or inrush current. Relays that employ waveform recognition, for example, to block the differential function from operating during inrush conditions, can be tested by use of COMTRADE files or real-time simulation techniques. Similar types of test file cases could generally be applied to devices without harmonic waveform recognition.

For relays with internal compensation, three-phase testing will simplify the evaluation of the relay performance.

For minimum pickup tests, a current source is used to inject current into the overcurrent relay(s) to verify the threshold for tripping. The timing of the overcurrent relay in a transformer protection scheme is typically slower and is used as a backup protection to the current differential relay.

Voltage tests verify operation for voltage-dependant elements. Where overexcitation is applied, system testing may involve the testing of threshold set points under steady-state conditions as an initial set of tests followed by simulated volts/Hertz (V/Hz) conditions using transient simulation tools or use of COMTRADE files from system events to verify the overexcitation performance for a generator step-up transformer or for a true power system condition with high magnitudes of volts/Hertz. The sudden pressure relay is tested by applying pressure to the pressure switch and observing the alarm and trip contacts for proper operation. A manual trip is initiated to test the auxiliary and lockout relays for proper operation of the above relay schemes. Also, SCADA tests are applied to ensure all alarms and targets are operating properly.

Maintenance tests for transformer protection may need to be conducted with the transformer energized. Therefore, the proper isolation of the elements under test is critical. It is important to keep some levels of overlapping protection in service when maintenance tests are performed with the transformer energized. The tests involve periodic testing of the transformer protective scheme. The tests may not be as comprehensive as the commissioning test; however, it covers checking out all critical functions of the protection system. Steady-state tests are widely used when applicable for relay periodic maintenance and involve the use of current and voltage elements. Output contacts are also verified for proper functioning.

### 6.3.3 Power transformer thermal protection

In order to assess dynamically the transformer's real power operating margins, especially in the presence of overload conditions, a commonly adopted method is thermal protection. Thanks to the adoption of these facilities, it is possible to use the full capacity of the transformer, which implies lower lost revenues or costly upgrades.

Thermal protection of power transformers requires an accurate prediction of the evolution of the hot-spot temperature in the top or in the center of the high- or low-voltage winding in order to verify that it is lower than the maximum allowable threshold temperature. Refer to IEEE Std C57.91™.

The knowledge of the winding's hot-spot temperature depends on the following:

- Ambient temperature
- Top oil rise over ambient temperature
- Winding hottest spot rise over top oil temperature.

The winding hot-spot identification is of critical importance for the development of the transformer overload protection. Because an increase of the hot-spot temperature produces an acceleration in thermal aging of the transformer, the monitoring of this temperature is essential to evaluate the loss of insulation life and to indicate the existing risk that free gas bubbles evolve at the hot-spot site in the presence of an emergency condition that dictates an abrupt change of load. See Lahoti and Flowers [B29] and IEEE Working Group K3 [B31].

Some of the power transformer thermal protection methods are realized as follows:

- An overcurrent relay that produces an inverse time-current characteristic by integrating a function of current  $F(I)$  with respect to time. The overcurrent characteristic emulates the shape of the transformer thermal characteristic and should be closely coordinated with it. The inputs for this coordination process are the load curves and ambient operating temperature conditions, assuming a fixed conservative profile for them. See Zocholl and Guzman [B38].
- A microprocessor-based relay starting from the acquisition of easily measurable variables (such as the environmental temperature, the transformer top oil temperature, and the load current) solves the transformer's heating equations determining the corresponding hot-spot temperature evolution (commonly referred to as indirect protective systems).
- A protective system employing a direct hot-spot temperature acquisition module that measures the winding temperature profiles in several internal points by a fiber optical temperature-sensing-based technology.

*Overcurrent relay-based thermal protective systems* process only the transformer's load current. They are, therefore, not subject to sensors' faults, measuring errors, and corrupted data.

Because the coordination process between the relay's overcurrent characteristic and the transformer's thermal characteristic is realized on the basis of the specific transformer thermal parameters, which can vary considerably from one transformer to another and drift for aging, it could become susceptible to

parameter variations. To manage these uncertainties, overly conservative factors are applied, and the transformers are underutilized to keep suspected hot-spot portions of the conductor from overheating and failing prematurely.

*Indirect protective systems* acquire a set of routinely measured variables and identify the unknown evolution of the hot-spot temperature profile by solving the transformer thermal model. Thus, they could be subject to sensors' faults, measuring errors, and corrupted data.

Moreover, because these methods are based on a built-in thermal equivalent model that requires some specific transformer data, which could be affected by various uncertainties, they could become susceptible to parameter variations. Large uncertainties come from several sources such as the oil time constant and the winding hot-spot time constant; oil viscosity and winding resistance are functions of the load pattern, the ambient temperature, aging, constructive tolerances, and so on. These uncertainties affect obviously the accuracy of the calculations, and considering that the loss of life is an exponential function of hot-spot temperature, the adoption of actual thermal models can produce errors in determining the real-time transformer overloadability rating.

*Direct thermal protective systems* acquire the hot-spot temperature profile by a distributed winding measuring system. They could, therefore, be subject to sensors' faults, measuring errors, and corrupted data.

### 6.3.3.1 Testing procedure

To test the performances of power transformers thermal protective systems based on indirect or direct methods, it is possible to adopt the test setup reported in Figure 10. It simulates, by an electronic load, the stress from realistic operation and acquires, through a measurement station, the load current, the transformer top oil temperature, the weather conditions, and the corresponding windings hot-spot temperature computed by the device under test (DUT).

All sensors are interfaced with a data acquisition unit, which is used also for controlling the programmable electronic load, and a data logging system to record, with a time period of 5 min, the entire set of measured variables.

With the above-mentioned measurement station, the test program, starting from a cold thermal state, simulates a realistic daily loading pattern characterized by several overload conditions. The gathered data are then organized into two different sets: one containing the hot-spot temperature profile computed by the DUT and another containing the corresponding hot-spot temperature profile computed by solving a suitable transformer thermal model using the available external variables acquired (load current, top oil temperature, environmental temperature, etc.).

If these two profiles appear incoherent, especially during the overload conditions, then the DUT operation appears not reliable. Obviously, small variations between these profiles could be considered admissible because they could depend on the accuracy of the thermal model adopted.

The same test station could also be employed to test the performances of overcurrent-relay-based thermal protective systems. In this connection, the measured variables could be adopted to compute the maximum hot-spot temperatures that trigger the overcurrent relay operation.

As far as the load pattern adopted during the test procedure, the profile reported in Figure 11 could be adopted. This profile is expected to be representative of the different operating conditions of the transformer as it contains both situations of normal load and an overload condition of about 4 h (around the 7th hour of functioning).

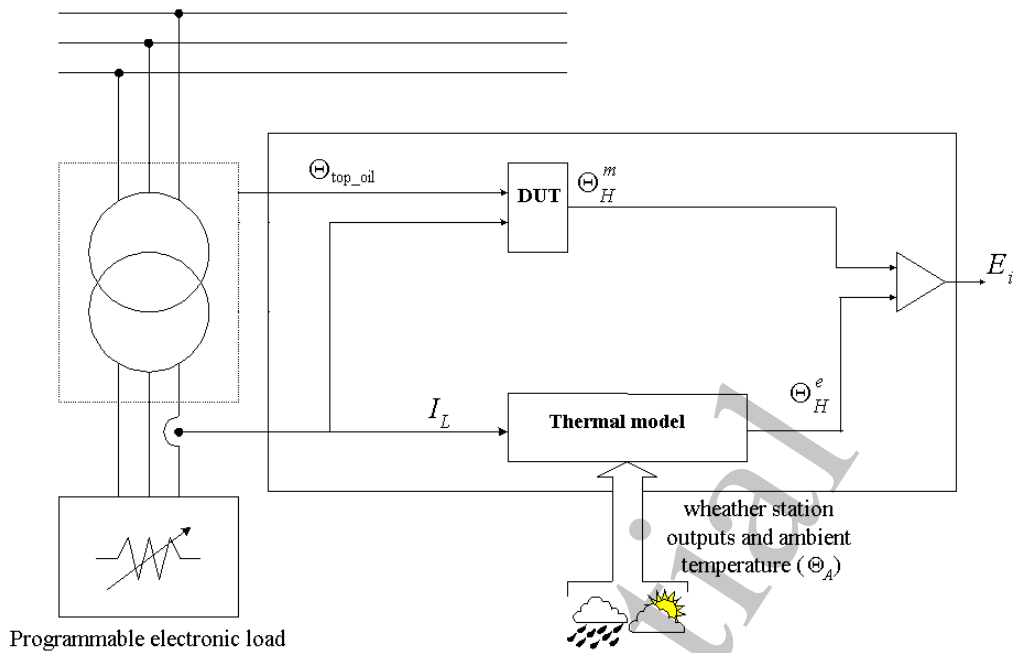

Figure 10—Test setup for noninvasive thermal protection systems

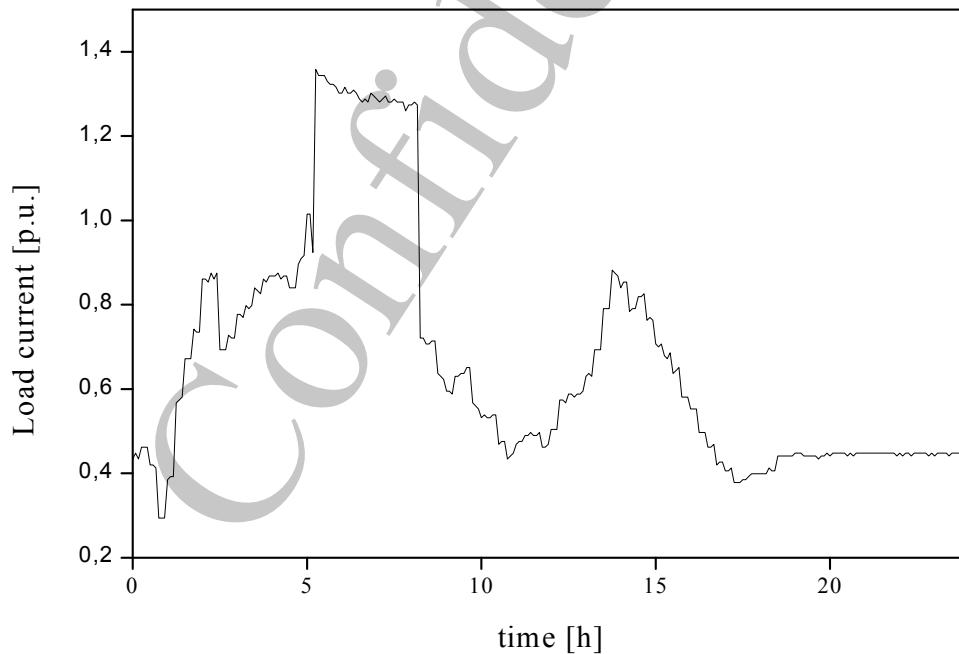

Figure 11—Test load current profile

The same concepts could also be extended to test the performances of power transformer's thermal protective systems during their normal operation. In this case, the load current is imposed by the electrical network, and it is only necessary to acquire the observable variables for daily operation in order to make the testing procedure less sensitive to the initial transformer thermal state. These data could be then

processed in order to compare the thermal state returned by the DUT and the thermal state assessed by solving the transformer thermal model. Refer to Annex D for additional information.

#### **6.3.4 Lines with series transformers as part of the line**

When a power transformer is part of a transmission line, the line breakers are the source for both the line and the transformer. Figure 12 shows a line/transformer configuration, each equipped with redundant protection.

In this configuration, several system tests, as well as interlocking tests between line protection and transformer lockout conditions, may need to be verified. The transformer is shown with multiple levels of protection, and all transformer protection, including the sudden pressure and low oil detection, initiates the trip signal to the source location. Once the trip is activated for transformer troubles or faults, breaker closing may be blocked. In such applications, telecommunication protection is applied. When the transformer protection detects a problem, transfer trip signals are transmitted to the station to open the source breakers and block reclosing as applicable.

In addition to the listed transformer protective functions, there may be other devices that would initiate the trip signals to isolate the transformer. Examples include low-voltage transformer protection or the low-voltage winding breaker failure condition, where low side winding is equipped with a breaker. Likewise, breaker failure protection of the source breakers (transmission-line breakers) would need to isolate the transformer lower voltage windings if the lower voltage windings have sources. Proper performance and interlocking for each of these schemes need to be verified as part of the overall line/transformer configuration.

Because bus configuration at the source may be different for different installations, the tests should be adjusted accordingly to reflect the appropriate levels of tests. Figure 13 shows one example where the source to the transformer is a double bus (or Main/Aux) configuration with a substitute breaker. In this application, the substitute breaker can be used to allow the transformer to remain in service. When the transformer protection detects a problem, transfer trip signals are transmitted to the station to open the source breakers and block reclosing as applicable. Therefore, the scheme testing should include steps that would verify the substitute breaker will isolate transformer faults and perform associated interlocking similar to the main breaker normally supporting the transformer at a distance location.

Additional scheme performance testing is required when the application includes some level of intelligence to differentiate line faults near the transformer, low-voltage winding breaker failure versus transformer trouble. For example, if the scheme design allows for reclosing after line faults, then the interlocking with transformer lockout devices may need to be verified.

Where multiple levels of telecommunication routes to the source breakers are used, the scheme should be repeated for the alternative path. In addition, maintenance flexibility should be verified as part of the overall performance evaluation.

For fused transformers such as distribution transformers, a sensitive negative sequence relay or a neutral transformer protective relay can be applied, in which case system testing is extended to include this application. Also, where a transfer trip is applied as part of the transformer protection scheme, testing would validate functionality.

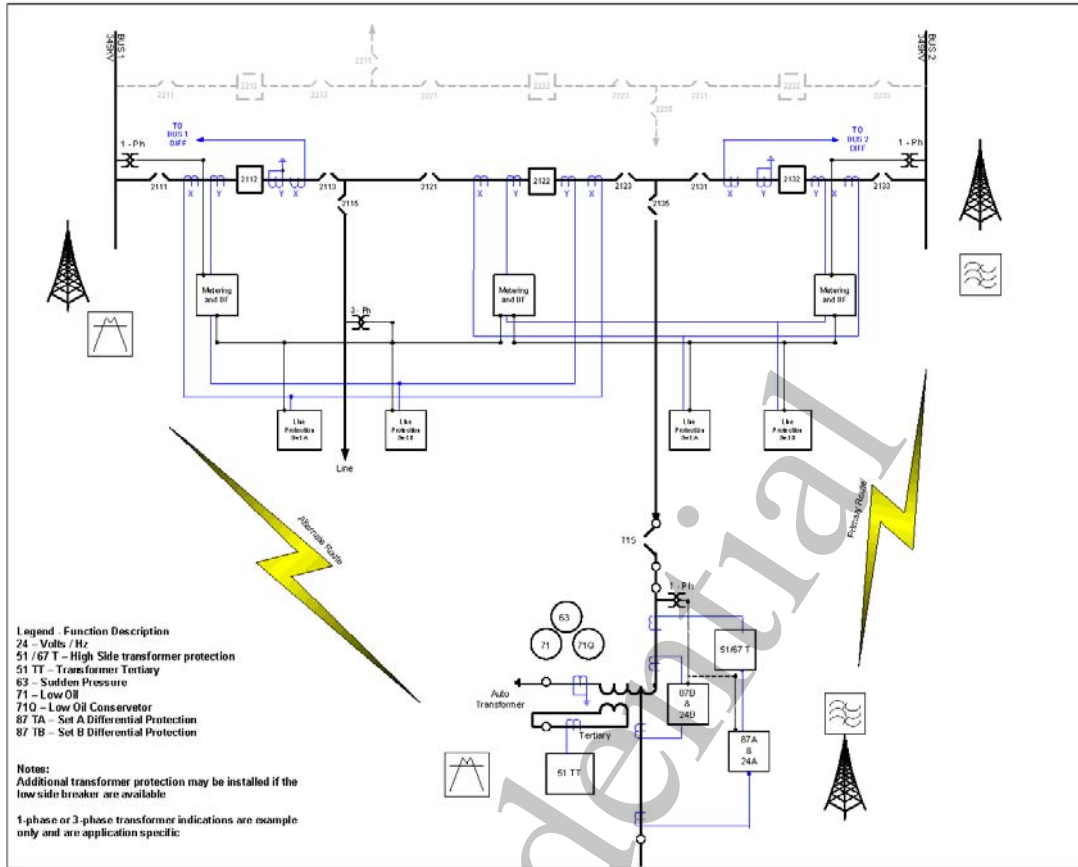
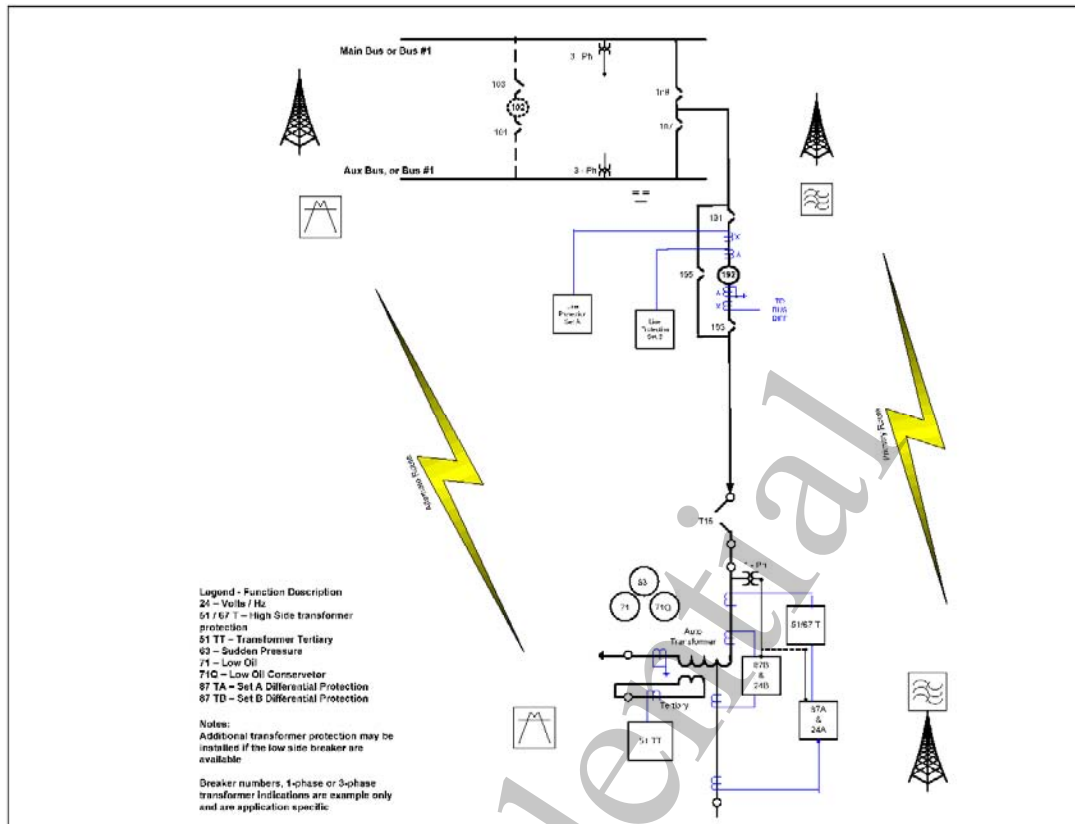

Figure 12—Typical protection for power transformer included in transmission-line zone of protection, line with a series transmission transformer with transformer part of the line (using redundant communication paths)



**Figure 13—Line with a series transformer-source bus configured as a double bus and a substitute breaker**

## 6.4 Distribution protection

Similar to transmission protection, testing of modern distribution devices and schemes requires the availability of a set of tools that will simplify the testing process, and at the same time, it will prove the high quality of the testing process.

The functionality of modern state-of-the-art distribution feeder protection relays includes the following:

- Basic fault protection
- Advanced protection schemes
- Abnormal system conditions protection
- Load-shedding
- Automation
- Monitoring
- Recording
- Analysis



### 6.4.1 Protective device functions and testing

The key function for a microprocessor-based device used in distribution protection is to detect and clear short-circuit faults that can damage substation equipment or create conditions that affect sensitive loads. This is achieved through the use of instantaneous, definite, or inverse time-delayed overcurrent elements operating on phase, negative, or zero-sequence currents.

The overcurrent protection elements may be directional or nondirectional and, in some cases, can have additional voltage supervision.

The functions in the relay have a hierarchy that needs to be considered for the testing of the device (see Figure 14). First of all, the secondary currents and voltages that are applied to the distribution protection relay are filtered and processed in the analog input module and provide instantaneous sampled values to the internal digital data bus of the microprocessor-based device. These sampled values can be recorded when an abnormal system condition is detected or used to calculate the different measurements or current and voltage phasors used by the different protection functions.

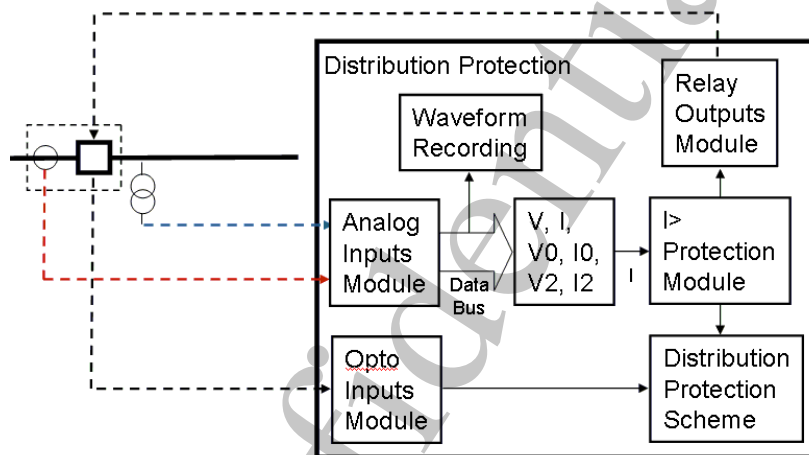

**Figure 14—Distribution protection block diagram**

The outputs of the measurement elements become inputs to protection or other functional elements of the device. Each basic protection element operates based on a specific measured value—phase or sequence current, voltage, frequency, and so on. The measurements of active, reactive, and apparent power or power factor are also usually available from the relays if required in the substation automation system.

When a protection function element detects an abnormal condition, it may operate and issue a trip command to clear a fault. It may also interact with other protection elements in an advanced distribution protection scheme used for acceleration or adaptation of the relay to changing configuration or system conditions.

Some of the most common distribution protection logic schemes are as follows:

- Cold load pickup
- Fuse saving scheme
- Feeder blocking scheme
- Sympathetic trip logic scheme
- Selective overcurrent scheme

- Distribution bus protection scheme
- Backup selective tripping scheme
- Breaker failure protection scheme

The multifunctional distribution protection relays also perform automatic functions such as multishot reclosing and local backup protection such as breaker failure protection.

Several distribution feeder relay functions can be used for load shedding during wide area disturbances or, in the case of islanding parts of the system, where the feeder or feeders are located. These include frequency, rate-of-change of frequency, or average rate of change of frequency or voltage functional elements.

The successful detection and clearing of any abnormal system conditions is affected by the correct configuration and operation of the protection functional elements. It needs healthy secondary current and voltage circuits as well as breaker trip or close circuits. This allows the relays to perform monitoring functions such as trip circuit supervision, current and voltage circuit supervision, or different breaker monitoring functions.

Last, but not least, the relays are also used as the first level in the hierarchy of a substation or system analysis function. Based on the prefault and fault currents and voltages, they calculate the location of the fault, the magnitude and angle of the currents and voltages before and after the fault, the duration of the fault, and other parameters.

#### 6.4.2 Testing of multifunctional distribution protection devices

The testing of modern multifunctional distribution protection devices requires the use of advanced test equipment and software tools that can simulate the different system conditions and status of primary substation equipment or other multifunctional microprocessor-based devices. The test system should be able to replay COMTRADE files from disturbance recorders and/or produced by transient simulation tools. It should be able to apply user-defined current and voltage signals with settable phase angles as well as to execute a sequence of predefined prefault, fault, and postfault steps (Figure 15).

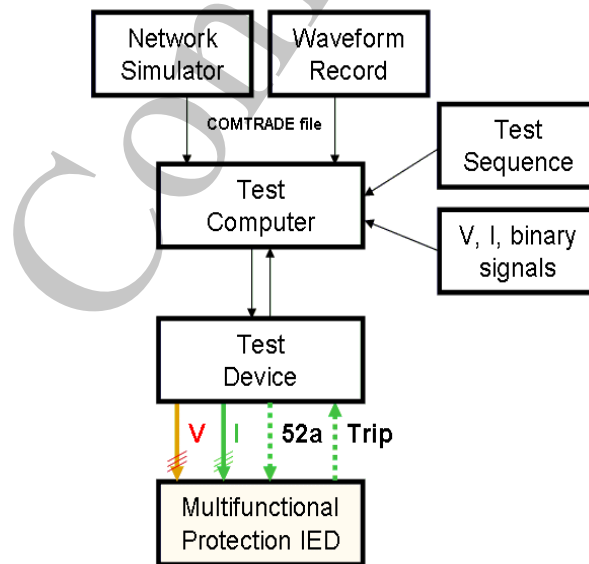

Figure 15—Test system block diagram

These test values can be used as part of both commission testing as well as routine maintenance testing. The testing of the different microprocessor-based device elements has to start from the bottom of the functional hierarchy and must end with the most complex logic schemes implemented in the device. Protective relays with such schemes operate based on the state of multiple monitored signals such as blocking signals, breaker status signals, and relay status signals. Time coordination of these signals and synchronization with the prefault and fault analog signals is required in order to perform adequate testing of these types of schemes.

Figure 16 shows a simplified way for the test device to properly simulate the distribution protection environment shown in Figure 14 as well as to monitor the operation of the relay under the simulated conditions.

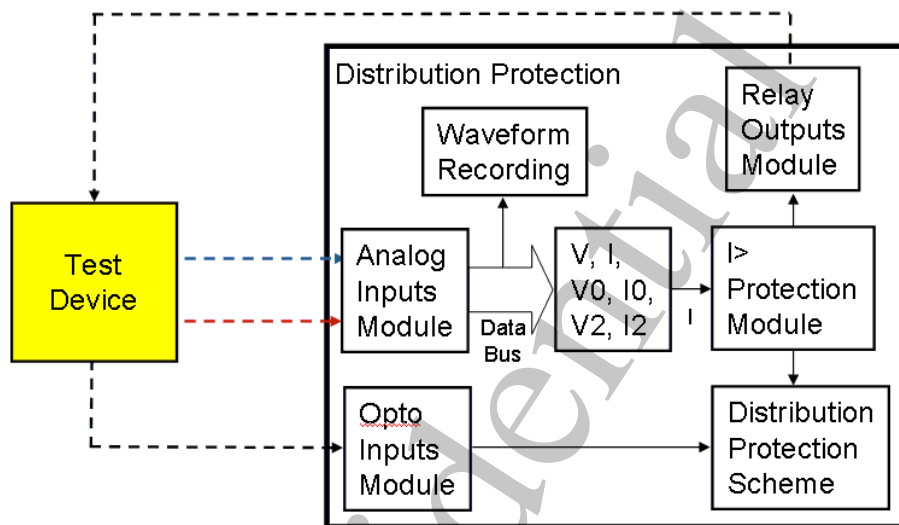

Figure 16—Testing of distribution protection microprocessor-based device

### 6.4.3 Testing of distribution protection schemes

The testing of distribution protection schemes is the final step in the testing of a distribution relay, and it is based on the assumption that all individual protection elements have already been tested and proven to be operating correctly.

The conventional test process requires the programming of the test device (test set) to perform prefault, fault, and postfault steps in the simulation of the changing power system parameters in order to evaluate the performance of a distribution protection device with advanced scheme logic.

There is a need for different options for testing of distribution protection logic schemes based on the purpose of the test. Three typical cases are as follows:

- Complete evaluation: All logic schemes are selected in a “point-and-click” manner, and the test software automatically executes a series of predefined tests, measures the relay’s response, analyzes the results, and prepares the test report.
- Testing of a specific logic scheme: This scheme automatically executes all tests required for the selected logic scheme, measures the relay’s response, analyzes the results, and prepares the test report.

- Testing of a specific logic scheme for a specific condition: This scheme automatically executes a single test required for the selected logic scheme, measures the relay's response, analyzes the results, and prepares the test report.

Different signals required by the distribution protection logic schemes in modern protective relays have to be considered in the process of defining what tests should be performed in order to verify the functionality and the correct settings of such schemes.

The simulation of the relay environment is also affected by the location of the fault if it is on a downstream section of the protected feeder or on an adjacent feeder.

#### **6.4.3.1 What is commonly tested?**

The testing of distribution protection schemes is intended to evaluate their performance under different fault, system, and breaker conditions.

Different tests are designed to monitor the relay operation for fault conditions, such as follows:

- Faults on the protected feeder
- Faults on an adjacent feeder
- Distribution bus faults
- No fault

Because the distribution protection logic and schemes are tested in this condition, the relay reaction to the receiving of correct control signals under the above-listed fault conditions is tested as well. These test values can be used as part of both commission testing and routine maintenance testing.

#### **6.4.3.2 How are the tests performed?**

Tests of distribution protection logic schemes are generally performed in a way to mimic closely real power system conditions. The sequence of steps in a test varies based on the function of the specific scheme and possibly under different power system operating conditions.

For example, if the test is for a distribution bus protection scheme and the test condition is a distribution bus fault, the sequence will include only the following three steps:

- Prefault with breaker in a closed position, nominal voltage and normal load current conditions
- Bus fault condition
- Posttrip condition with the low side transformer breaker opened and no current

When a more complex scheme (for example, a fuse-saving scheme) is tested, the number of steps will increase accordingly. Figure 17 shows the waveform recorded by the tested relay simulated system conditions for an unsuccessful reclosing.

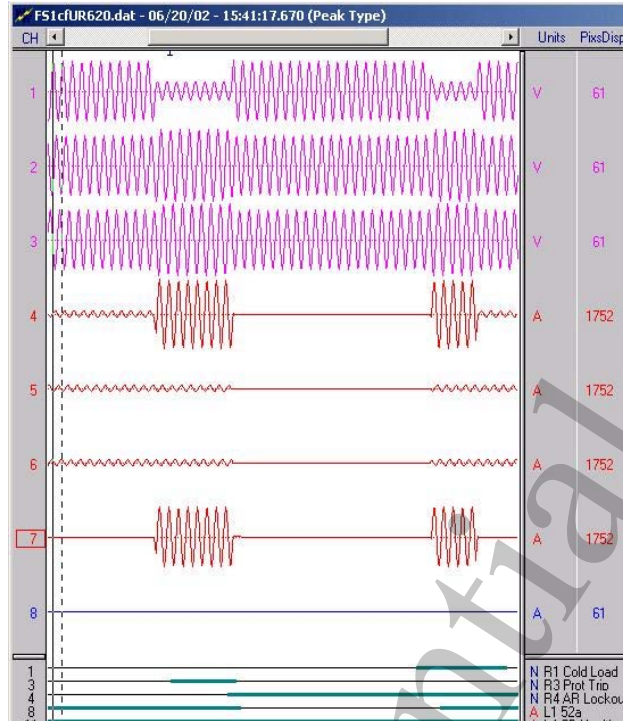

Figure 17—Unsuccessful reclosing simulation

#### 6.4.3.3 Test results analysis

The results from each performed test are automatically analyzed by the test software. The analysis is based on an expert system comparing the operating time of a combination of monitored protection elements that operated during the test.

The expected operating time of the monitored protection elements is defined based on the protective relay's technical specifications. The results are displayed in a graphical format in the user interface and in detail in an automatically generated test report.

The test result analysis is often used for both commission testing and evaluation of scheme performance during maintenance tests.

#### 6.4.3.4 Steps in testing

There is a sequence of steps related to the scheme testing that depend on the goals of the test and the level of knowledge of the relay under test and its operating principles.

First, the user has to become familiar with the principles of operation of the test object (in this case, a microprocessor-based distribution feeder protection relay with preprogrammed logic schemes) and the sequence of events that result in an accelerated or time delayed trip while implementing a specific logic scheme. This information is usually available in the user's manual of the tested relay. Animations based on the typical distribution protection schemes principles showing the sequence of events and the operation of relay function elements can help the user easily achieve this goal (Figure 18).

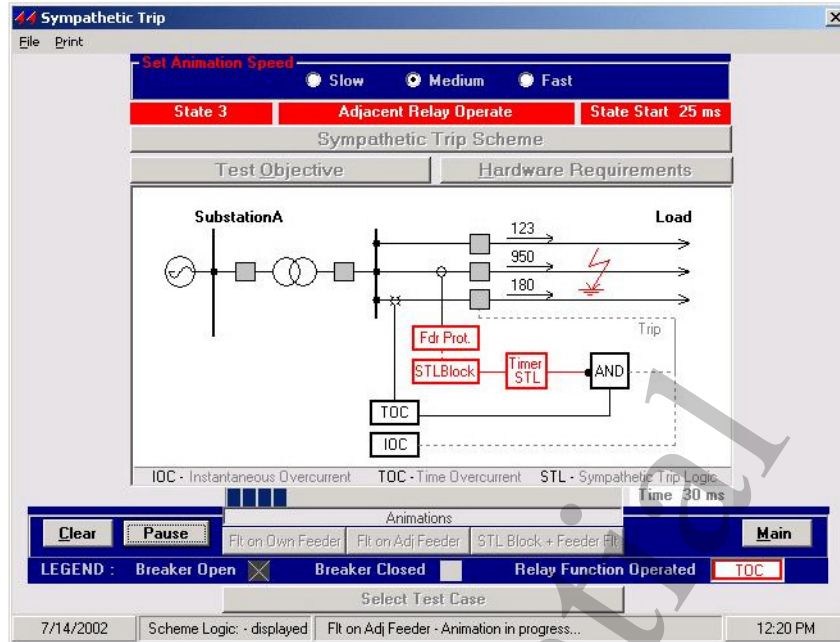

**Figure 18—Scheme animation for user training**

If the goal of the test is a benchmark test of the distribution protection logic schemes of a new to the utility distribution relay, the user should use the multiple scheme test mode. It executes a series of tests selected by the user, evaluates the relay operation for each of the individual tests after their execution, and displays the result in a graphical format (Figure 19). The overall performance of the relay is evaluated after all selected tests have been completed and a report, including the operating times of monitored functions, is generated.

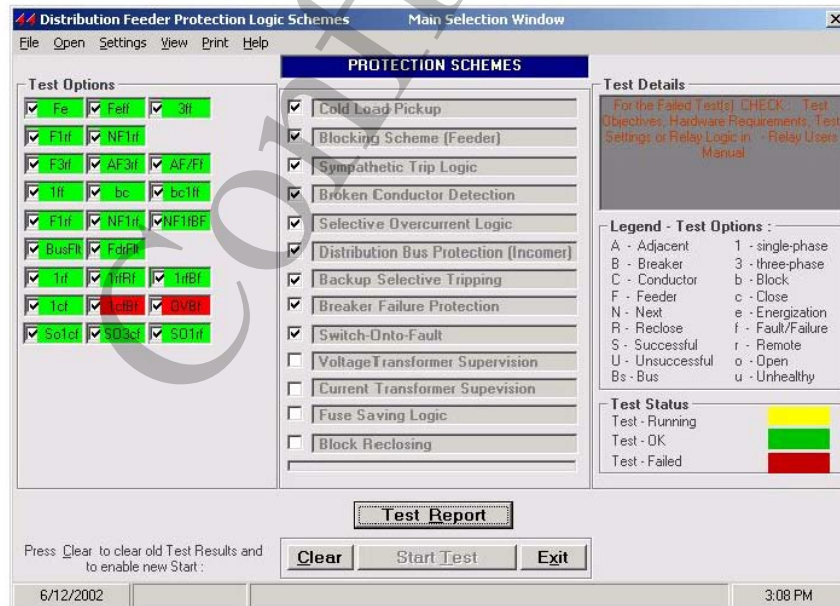

**Figure 19—Multiple schemes test mode**

When the task is to test only a specific distribution logic scheme, the single scheme test mode should be used (Figure 20).

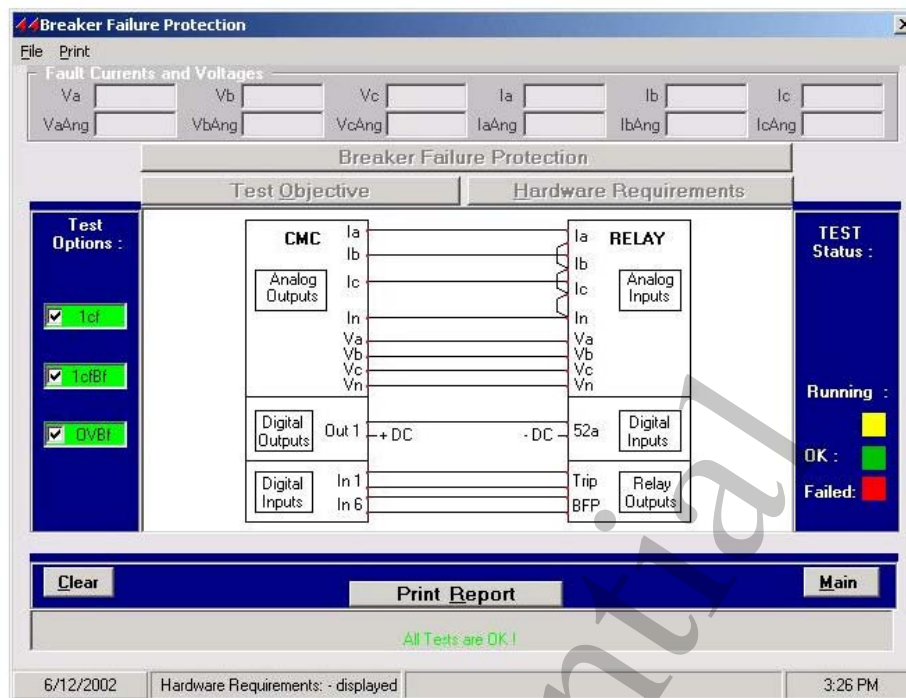

**Figure 20—Single scheme test mode**

Maintenance tests for distribution systems may need to be conducted under energized conditions. Therefore, proper isolation of the elements under test is critical. The tests involve periodic testing of the protective scheme or evaluation of captured events from an actual fault on the system. The tests may not be as comprehensive as the commissioning test; however, it covers checking out all critical functions of the protection system. Output contacts are also verified for proper functioning.

## 6.5 Shunt capacitor protection

Testing of relays for shunt capacitor banks is not much different than testing normal overcurrent relays. Some smaller banks are fused for fault protection. Depending on the size and configuration of the bank, there may be an electronic controller or separate relays installed to accomplish some of the following functions:

- Bank unbalance detection due to failed capacitors
- Bank bus fault protection
- Under/over voltage to automatically switch the bank on and off
- Capacitor discharge timer

The testing of these functions for a new installation or for periodic maintenance is quite similar. Commissioning tests will be described with the differences noted.

### 6.5.1 Bank unbalance

Unbalance protection will consist of neutral overvoltage or overcurrent relays to detect failed capacitors. The settings are typically designed to alarm at the first threshold and trip at the second. In the initial commissioning tests, failed capacitors are simulated by shorting or disconnecting capacitor cans one at a



time until the alarm and trip threshold settings are exceeded. The process of shorting or removing capacitor cans may require several switching steps to allow the capacitors to be discharged, and proper grounding procedures are followed to access the capacitor platform. For maintenance, the trip levels are simply checked without removing capacitors. For fuseless or internally fused capacitor banks where partial unit failures are monitored, capacitor removal may not fully test all the protection threshold setpoints. As design and capacitor bank configuration vary based on specification, users often consult with capacitor manufacturers for additional guidance on threshold setpoint verification methods.

### 6.5.2 Bank bus fault

This is typically overcurrent protection. Testing consists of testing the trip threshold level and timing to actually trip the breaker and verify the trip circuit. This can be done every time the relays are tested.

### 6.5.3 Automatic bank switching

For undervoltage and overvoltage automatic bank switching, the pickup threshold of each device is verified. The bank can be actually switched ON and then OFF using secondary injection of the voltage signals to verify operation. If a discharge timer is used, the scheme can be verified by proving that the bank cannot be switched back until the timer has timed out to allow for capacitor discharge. It should also be verified that the timer does not start until the bank is switched from “ON” to “OFF.”

### 6.5.4 Synchronous closing tests

Synchronous closing is often associated with reducing potential for large transient voltages where lightning arrestors or other station equipment (e.g., transformer bushings) may need to withstand such voltage momentarily. One such example involves shunt capacitor installations when closing a switch to energize a capacitor may generate transient overvoltages beyond rating of some of the equipment at the station if proper measures are not accounted for and employed during engineering phases.

When preparing for shunt capacitor protection and interlocking system testing, knowledge of components, switching sequence, functional performance desired, types of system studies conducted, and type of switches or breakers used in advance of the tests is useful.

Shunt capacitor installations are referenced in segments, banks, or steps based on the reactive support of the respective step once energized. Each capacitor step is controlled by a circuit switcher or circuit breaker. For the purpose of capacitor control switch testing, both types of installations (circuit switcher or circuit breakers) are addressed similarly. Therefore, only references are made to the circuit breaker beyond this point.

Some of the methods for capacitor reinsertion are as follows:

- Preinsertion resistors
- Synchronously controlled breaker

To minimize the transients associated with the energization of the capacitor steps, breakers having the ability to close synchronously at zero voltage are used. Because the energization sequence of different steps may produce different percentages of overvoltage, transient studies are performed in advance to determine whether additional measures need to be taken. For example, preinsertion resistors may be needed in addition to the synchronous closing.

In the case of circuit breaker installations where preinsertion resistors are not utilized, the transients associated with the energizing capacitors synchronously controlled breakers may be used to assist in closing the breaker at or near zero voltage. Energizing the first capacitor segment may produce higher transients in the substation than when switching remaining segments. Because the sequence for closing of



capacitor segments may vary, all switches are usually rated and designed to withstand the worst transient voltages.

When inherently restrike-free circuit breakers are used, to minimize potential for a restrike, tests should show that it will not cause the operation of the existing arresters at the station.

There are some contingency conditions that could result in the operation of an arrester in a distribution substation because of a restrike.

When a capacitor control breaker is used, the breaker may have additional preinsertion resistors beyond the ability to close synchronously at zero voltage.

The switches (or breakers) that are used for shunt capacitor insertion are designed to withstand transient recovery voltages at the substation and are designed based on transient study results. When breakers are used for each segment, the breaker can function as a means of the capacitor protection as well as of the capacitor insertion.

Therefore, system testing involving synchronous closing may include measurements of transient voltages at the station as well as one station away with the capacitor switches opened and closed several times. In stations with multiple capacitor steps, variations of switching step sequence of different steps should also be considered.

Other factors related to capacitor breaker applications include studies of transient recovery voltage (TRV) rate and the rate of rise of recovery voltage. The TRV for the capacitor breakers for faults between the series reactors and capacitors is dependent on the various stray capacitances in the vicinity, such as the capacitance in the breaker bushings and the capacitance to ground of the high-voltage bus between the breaker and the reactor.

Maintenance tests for shunt capacitor protection involve testing of the shunt capacitor protection described above. Depending on the complexity and levels of protection applied, some tests may be conducted with the shunt capacitor banks energized. Some tests such as unbalance protection may require the capacitor bank to be removed from service. The tests may not be as comprehensive as the commissioning test; however, it covers checking out all critical functions of the protection system. Output contacts are also verified for proper functioning. Refer to IEEE Std C37.99™ for shunt capacitor protection applications and additional information regarding maintenance testing.

## 6.6 Bus protection

By virtue of the application, bus differential protection can be tested at a single location. A bus differential protection scheme can be represented as summation differential using simple nondirectional electromechanical induction disk-phase time overcurrent relays (instantaneous elements are generally not used). Another scheme includes the solid-state high-impedance differential. The most recent practice has been to use microprocessor-based multifunction relays, enabling the phase time overcurrent (TOC) elements emulating an electromechanical induction disk relay.

The tests performed on the phase TOC installations are as follows:

- Physical examination of each individual relay's components (control spring, contact condition).
- Calibration tests including minimum pickup and timing tests.
- Functional tests, manually initiating trip contacts to operate the auxiliary lockout relay.
- Phasing tests to verify the current transformer connections, including a check to make sure the current in each phase is zero with all feeder contributions from the bus included; then checking

each feeder's contribution by removing its contribution, one at a time, and verifying that its contribution shows up in each phase.

For the high-impedance bus differential, the tests are as follows:

- Physical examination.
- Voltage pickup, taking care to avoid leaving voltage applied to the relay for longer than 10 s.
- High-set overcurrent unit, when applicable.
- Functional tests by manually firing the internal SCR to operate the auxiliary lockout relay.
- Shorted bus differential CTs circuits. The bus differential scheme design may have provisions to disable the bus differential protection on short-circuit detection.

The following tests may also be necessary:

- Accuracy pick-up current (certification test, acceptance test, and commissioning test).
- Accuracy operating characteristic (certification test and acceptance test).
- Influence frequency and harmonics on accuracy pickup current and operating characteristic (certification test).
- Operating times (certification test, acceptance test, commissioning test, and application tests).
- Stability for load current and through current faults (certification test, acceptance test, commissioning test, and application test).
- Influence CT saturation with and without remanence on operating time, including different types of transformers in the bays (certification tests and application tests).
- Influence CT saturation with and without remanence on stability for through current faults, including different types of transformers in the bays (certification tests and application tests).
- Influence evolving faults and evolving external to internal faults on stability and operating times (certification test and acceptance test).
- Verifying correct operation of breaker failure protection (certification test, acceptance test, and commissioning test).
- Selectivity bus section operation (certification test, acceptance test, and commissioning test).

Other types of bus differential protection schemes, such as those that use paralleled CT connections as input to the bus differential, and most low impedance schemes that use individual restraint inputs, can also be verified for open and shorted CT connections.

Additional commissioning and maintenance testing considerations are included in IEEE Std C37.103™-2004 [B22].

## 6.7 Breaker failure protection and control

Circuit breakers can fail to trip for various reasons. When this happens, breaker failure protection detects the continued presence of the fault and trips adjacent breakers to isolate the fault after a predetermined length of time. Breaker failure protection is used in transmission and distribution systems where delayed backup clearing can threaten system stability or cause outage of too many circuits because of remote backup. Fast fault clearance and minimization of outages also improves power quality.

Breaker failure protection, when properly designed, applied, tested, commissioned, and maintained, enhances power system reliability and stability. However, when it misoperates, it can easily have disastrous consequences; hence, the security of the breaker failure protection system is of paramount importance, and comprehensive testing is required for any breaker failure protection system. Refer to IEEE Std C37.119™.

The testing of any protection function should be performed in a way that matches as closely as possible real-life power system conditions. The sequence of steps in a test is a function of the requirements for the specific scheme and system condition. This is especially important in the case of breaker failure protection because of the importance of this function as well as because it can be implemented in many different ways.

Breaker failure protection testing requires a good understanding of the operating principles that are used in developing the function implemented in the protection under test. Before going into the testing requirements, the next section provides a brief description of the basic breaker failure principles and more common breaker failure protection schemes.

### **6.7.1 Breaker failure protection schemes**

The arrangement of the station bus and circuit breakers—straight bus, ring bus, breaker-and-a-half bus, or main-and-transfer bus—influences the implementation of the breaker failure protection. Breaker failure protection can be implemented as an individual protection scheme dedicated to a specific breaker, as a built-in auxiliary function in a multifunction relay (such as a numerical distance relay), or as a centralized breaker failure protection system for an entire bus. The latter could also be implemented as an integral part of a bus-protection system. The logic used in breaker failure protection schemes ranges from simple to complex.

The main principle employed in breaker failure protection is based on monitoring the current through the circuit breaker. After a protective relay trips because of a fault, it initiates a timer, and, if there is still fault current after it times out, it declares a breaker failure condition; otherwise, the scheme resets. Two common breaker failure schemes are shown in Figure 21.

Confidential

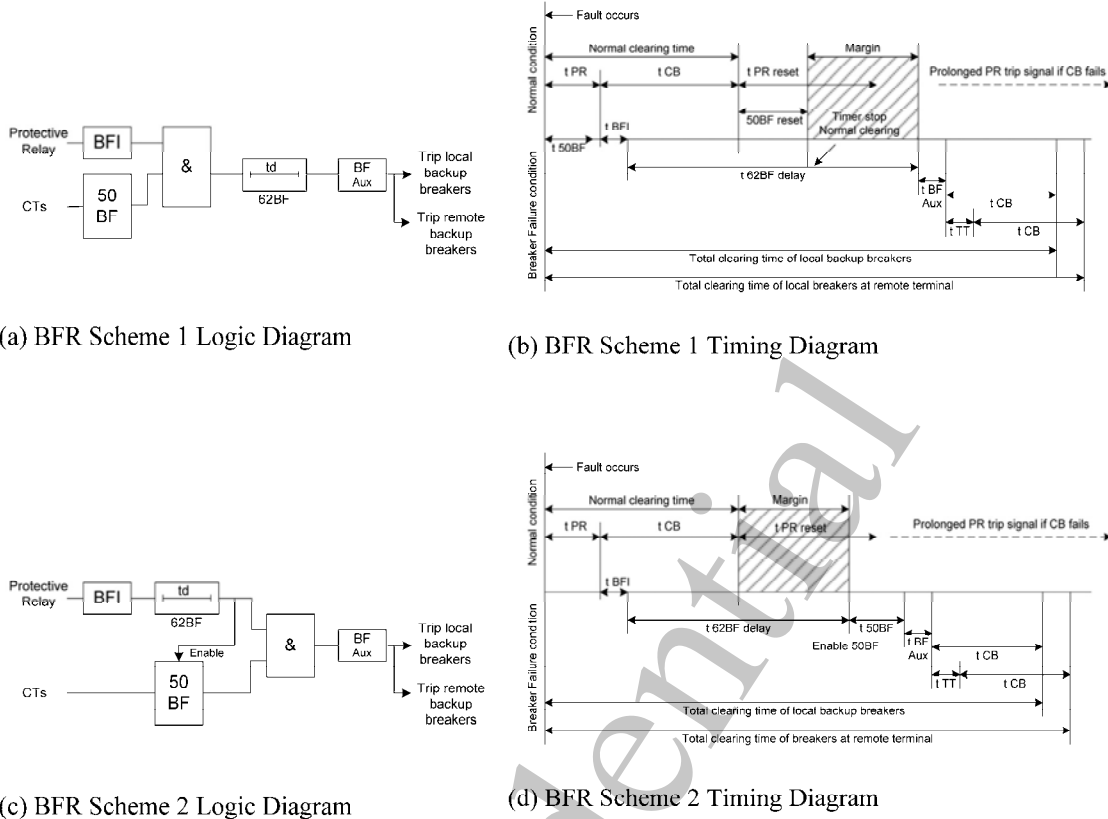

(a) BFR Scheme 1 Logic Diagram

(b) BFR Scheme 1 Timing Diagram

(c) BFR Scheme 2 Logic Diagram

(d) BFR Scheme 2 Timing Diagram

**Figure 21—Common breaker failure (BF) schemes**

In scheme 1, the timer is started only when both the protective relay and the fault current detector 50 BF have operated. If the breaker successfully clears, then 50 BF resets and the timer resets as well. If the breaker fails to interrupt the fault, the current detector remains picked up and the timer times out and issues a breaker fail output (BF Aux) and backup tripping occurs. Depending on design philosophy, the number of required contacts, the interrupting rating of the output contacts, or the relay targeting requirements, auxiliary devices may be used. Often, a lockout relay (86 BF) is used as an auxiliary device to trip adjacent breakers and to prevent closing of affected breakers.

In scheme 2, the timer is started and operated by the protective relay initiating signal. When the timer times out, only then is the current detector enabled. If the fault was successfully cleared, the current disappears and the current detector does not pick up; if the breaker fails, the current detector picks up and initiates backup tripping.

A third common scheme used in applications where there is no current or the current is not sufficient to operate the current detector, such as in transformer applications, tripping on unloaded long line on overvoltage conditions, generator applications, and so on. A tripping or lockout relay supervised by a breaker auxiliary contact can be used in a breaker failure scheme after a time delay. Because of uncertain reliability of the breaker auxiliary contacts, both 52a and 52b contacts are usually used in the scheme. In case of a discrepancy, it can be arranged to issue a time delayed alarm or indication.

It should be noted that many other variations of BF protection scheme logic do exist. Modern breaker failure schemes include such features as a control timer, BF initiate seal-in, use of separate current detectors, and timers for three-phase faults for ground faults, and for low-level currents with breaker auxiliary contact supervision. Re-tripping of the circuit breaker is sometimes used; this is usually routed via a separate circuit and dc supply to the second trip coil of the circuit breaker, either with or without

additional time delay. The use of single-pole tripping and auto-reclosing modifies the logic of the breaker failure scheme.

Recent breaker failure relays include other functions such as pole-discordance protection and breaker condition monitoring. Numerical relays also allow users to implement customized breaker failure protection scheme logic within a distance relay, transformer relay, and so on. Such logic can use digital inputs from other protective relays, breaker auxiliary contacts from one or more breakers, instrument transformer inputs, and arrange an internal Boolean logic with internal timers to implement a breaker failure scheme. The development of the IEC 61850 protocol with high-speed peer-to-peer communications has made it easier to implement breaker failure schemes over substation local area networks.

This guide provides only a brief description of more common schemes and general comments on other possible schemes that may be available. For a more complete coverage and description of breaker failure schemes, please see IEEE Std C37.119.

### **6.7.2 Testing breaker failure protection**

The type and coverage of testing varies significantly for functional and performance tests, commissioning tests, and routine maintenance tests.

The following testing guidelines apply to conventional BF schemes, in which the BF relay is in a physically separate device from the initiating protective relays. Schemes where the BF function is part of a protective relay could also follow these guidelines as part of an overall relay calibration/functional test procedure. BF protection implemented over a substation LAN requires additional scrutiny, and the best policy would be to consult with the manufacturer to determine appropriate testing methods.

#### **6.7.2.1 Functional and scheme performance tests**

The goals of functional and scheme performance tests are to verify that the complete breaker failure protection system functions correctly and performs satisfactorily even under the most unfavorable conditions (i.e., it should trip the adjacent breakers within the required backup time when the concerned circuit breaker fails to interrupt the fault and it should not trip when the circuit breaker operates normally).

Before doing the performance testing, the settings and functional operation of the protection scheme should first be verified. This includes testing the current detector pickup and dropout levels, operating times of timer relays, auxiliaries, and lockout relays. These simple tests can aid in analyzing problems later.

Performance testing should simulate prefault, fault, and postfault conditions including expected low to high range of load current and normal voltage (where required).

Testing should be done using sinusoidal currents as well as simulation of periodic transient currents. When a breaker interrupts the primary fault current, it is possible that a decaying dc current, called a CT subsidence current, still flows through the CT secondary circuit including the relay. This can substantially delay the dropout of the current detector and cause a misoperation or may need a longer reset time setting in the coordination timing diagram. While numerical relays employ algorithms to reject this dc decaying current or use fast dropout algorithms when dc decaying current is present, it is recommended that the relay be tested under these conditions.

The magnitude of the fault current affects the current detector pickup and dropout times. Low-level currents result in slower pickup, and high-level currents result in slower dropout. The level of dc auxiliary power supply also affects the performance of the relay and should be considered in some test cases.

For the breaker failure scheme 1, where the logic relies heavily on the dropout of the current detector to confirm that the breaker has tripped, it is important that the current detector dropout behavior and timing be

thoroughly tested using signals that simulate CT subsidence current. Figure 22 shows such type of simplified waveform.

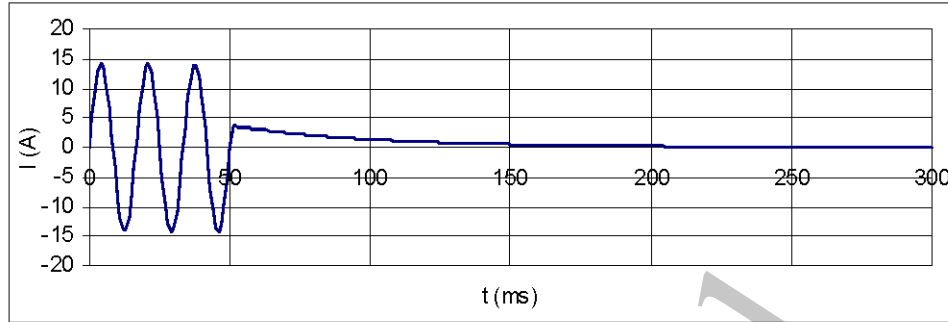

**Figure 22—CT subsidence current**

Transient files with such current waveforms can be played back using test systems that support this type of testing. The pickup time of current detectors should be faster than the initiating protective relay.

For the breaker failure scheme 2, which relies on the pickup of the current detector and where reset time does not influence the scheme logic, it is not required to test reset characteristics under subsidence current. However, the current detector operating time at currents slightly above the set pickup level should be verified as it has to be added to overall breaker failure backup time.

Because many breaker failure logic schemes exist, the actual relay logic should be well understood when testing a particular relay scheme. Some relays even allow the user to implement custom BF scheme logic.

The overall breaker failure protection system is typically tested by starting from a prefault state and then applying the fault to the breaker failure trip initiation of the backup breakers. This type of test verifies that the required minimum backup timing margin and maximum tripping time are satisfied. Testing fault current detector levels that result in maximum reset and pickup times of the current detector includes the simulation of CT subsidence current. The maximum expected circuit breaker clearing time is used because breakers can interrupt the current one cycle slower at currents below 25% of the maximum rating. Furthermore, the interrupting time may be longer on close-open duty.

The contact bounce of the protective relay and BF initiate signal can make the timer reset or run slower, further delaying backup tripping. Some relays implement input conditioning circuits to fill in the gaps. Some relays also provide a seal-in of the breaker failure initiate signal in case a line protective relay resets for close in faults with very low voltages. These conditions may be tested using test instruments that have high-speed (<1 ms) digital outputs to simulate contact bounce and control the outputs with high precision and can playback waveforms as shown in Figure 23. This type of testing will test the overall breaker failure timing accuracy and consistency for backup tripping.

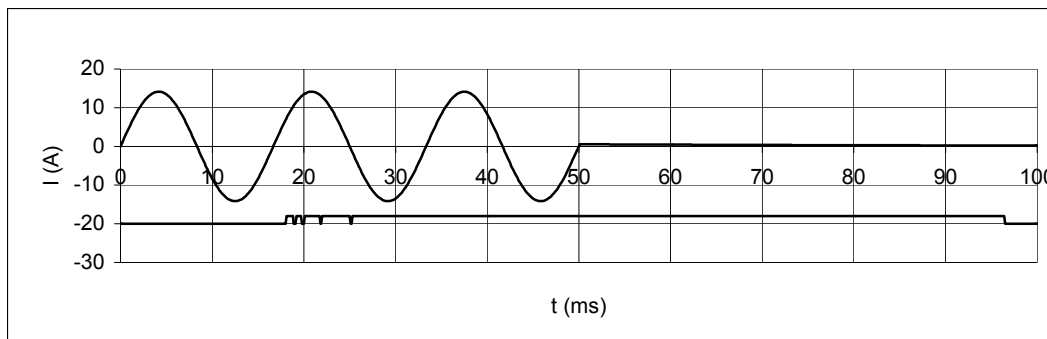

**Figure 23—Current waveform and protective relay contact bounce**

If the breaker failure protection is used in applications where it is supposed to operate even when current is low or nonexistent, such as on overvoltage conditions, transformer sudden-pressure trip, or Buchholz relay trip, it should be tested accordingly for stability when the breaker trips and for positive operation if the breaker fails. Failure of the circuit breaker auxiliary contacts should also be tested.

Depending on the design and logic implemented in the breaker failure protection scheme being tested, additional tests may be required. Such tests may include testing the control timer and retrips, simulating three-phase faults that require faster tripping than single-phase faults, testing breaker failure trip on low-level fault currents and current redistribution in multiple-breaker arrangements, evolving faults starting from one phase and spreading to two or three phases, use of circuit breaker auxiliary contacts instead of or in addition to current detectors, and so on.

It will also be necessary to test for stability of the breaker failure scheme in cases when it is used in an auto-reclosing scheme to ensure that the timing and stability are not compromised. Some of these tests may require a prefault condition, two or more sequential fault conditions, conditions during the dead time, and a postfault condition. When the breaker failure protection is used in single-pole tripping applications, the testing concept is similar but the conditions are more complicated to simulate; however, testing is even more necessary. Testing should verify that the breaker failure protection does not misoperate during the reclosing time when one pole is open even when the load current is high.

For breaker failure schemes that are implemented as an internal function of multifunction relays, the above tests should be done for initiation by the internal protective function, such as a distance function, and also for external initiation by other relays if they are connected as such.

For a centralized multibreaker failure protection system implementation, especially where switching of the current circuits and trip circuits are involved, the complete system logic must be verified by comprehensive testing at the factory, as field changes during commissioning can cause delays and can be very costly. If a utility implements a nonstandard special breaker failure scheme logic, it should first be tested thoroughly in a laboratory environment before being deployed out in the field.

If the test equipment does not meet the requirements for automatic analysis of the operation of the tested breaker failure protection system for the more complex tests, a fault recorder, if one is available, may be required to monitor all the voltages, currents, relay contacts, and simulated contacts (from the test set). This will demonstrate that the test results are properly analyzed for correct operation and are within expected performance requirements for stability when the associated circuit breaker successfully clears the fault.

### 6.7.2.2 Commissioning tests

The main goal of commissioning tests is to prove that the breaker failure protection system is implemented in accordance with the design for that specific application and to ensure that it will actually function according to the design and settings. When commissioning BF schemes that are add-ons to an existing station, it is imperative that drawings be thoroughly reviewed and understood because of the additional risks of dropping of loads, interrupting multiple transmission lines, tripping remote breakers, and causing system instability.

Commissioning breaker failure protection systems should include thorough checking and testing the wiring in accordance with the station drawings in addition to the relays and auxiliaries. The following should be verified and tested:

- Check that all isolating switches for initiates and trips are properly wired and functioning.
- CT ratios and complete circuit from the switchyard to the BF relay.
- All BF initiates from all protective relays and other control trip initiates that are connected to the breaker failure protection.
- All BF trips and retrips to all breakers involved as well as transfer trips.
- All BF auxiliary and lockout functions that prevent closing of affected breakers.
- Actual tripping of circuit breakers involved, including remote breakers, whenever possible.
- Physical inspection of individual relays (for electromechanical relays, additional mechanical inspection).
- Breaker 52a and 52b auxiliary signals, if used, by operating the circuit breaker and verifying connections at the BF relay.
- SF6 gas pressure indication if used.
- BF initiate auxiliary relay, if used, and BF initiate seal-in. Verify that the BF initiate auxiliary relay will properly reset after the main breaker trips with the trip circuit supervision relays and that other parallel trip initiates and other monitoring equipment are connected.
- All other breaker failure protection circuits for related features that are used such as selective initiation for three-phase faults and single-phase faults and per-phase initiation for single-pole reclosing applications.
- Verify connections to and the operation of all annunciation and monitoring equipment.
- Apply all BF relay settings specified by the protection engineer.
- Current detector pickup and dropout levels.
- Current detector pickup and dropout times.
- Timer values.
- Overall BF timing starting from BF initiation until:
  - 1) Relay resets, in case of breaker successful interruption
  - 2) BF auxiliary trip and transfer trip in case of breaker failure to trip



When commissioning breaker failure schemes, perform tests with fault conditions that test the entire BF system. Commissioning tests should include the following:

- Inject voltages and currents into the main protective relays and the BF relays to simulate internal as well as external fault conditions. The simulation should include prefault, fault, and postfault conditions. In some situations, the main relays and BF relays may use different current circuits and may even be located far from each other. This will require modern test systems to allow the overall system testing to be performed. Such requirements may include six or more current sources with high burden capability and/or three-phase test sets that are capable of being synchronized to provide simultaneous injection of test currents.
- Simulate an internal fault and failure of the breaker to trip and perform the following:
  - 1) Allow tripping through the retrip circuit, if used; measure the retrip delay and verify that the BF system is stable with this additional delay.
  - 2) If there is no retrip feature, allow breaker failure to trip the BF auxiliary relay and measure the overall fault interruption time as well as the BF time to trip the adjacent breakers.
- Simulate low load current and BF initiation that fails to reset after the control timer delay expires and then increase the current above the current detector setting; verify that the control timer prevents the BF scheme from operating incorrectly.
- Other more complex features such as selective initiation for three-phase fault and single-phase faults, per-phase initiation for single-pole tripping and reclosing applications, pole discordance logic, and so on, should be simulated and tested, if applicable, using appropriate fault conditions. This should test and verify the various timing and interlocking functions.
- Other circuits that cannot be directly operated for multiple times, such as circuit breakers (52a contact effect on BF protection) and other relay BF initiates, can be simulated using the test set digital outputs. However, these circuits should have been verified beforehand as mentioned above.
- Scheme testing with increasing circuit breaker tripping time (an extended fault current) until the BF false trips should also be performed to measure the total time margin.
- In the final testing, simulate breaker failure conditions that will allow actual tripping of the adjacent breakers at least once. The tests may be repeated several times to trip only one adjacent breaker at a time as allowed by system operators, including transfer trip of remote breakers.

The operation of annunciation and monitoring equipment should be verified during these tests. All these test cases should be monitored using DFRs and SERs to verify correct timing and operation. The test results should be analyzed to verify that adequate margins are met. The protection engineer should be involved in the analysis of the test results to see whether any setting adjustments are necessary.

### 6.7.2.3 Routine maintenance tests

After a breaker failure protection scheme is commissioned and already in operation, depending on the scheme complexity, the number of initiating devices and adjacent breakers to be tripped, testing the entire scheme may require a comprehensive and coordinated plan to minimize the potential impact of inadvertent operation during the tests. Therefore, it is advisable to isolate the corresponding circuit breaker during testing and to coordinate BF scheme routine maintenance and testing with maintenance or outages of the circuit breaker and other main equipment and relays. Also, see the cautionary note in 6.10.1 for testing with the entire scheme isolated.

In addition to relay settings, the commissioning test results as well as the “as built” scheme drawings are needed for reference during the testing process. The portion of the protection system being tested should be isolated completely in order to prevent initiation of other relays and possible tripping of adjacent breakers.

Breaker failure scheme tests should include the initiating protective relays up to the trip isolation points to the concerned breaker and the backup breakers. When breaker failure re-trip is implemented, tripping the breaker once by breaker failure protection is recommended. A selected subset of the commissioning test routines that covers the overall protection system should be performed; it should include prefault, fault, and postfault conditions. The test conditions should include faults that result in the breaker failure scheme to operate as well as verify that the scheme remains stable for a fault that does not require the breaker failure scheme to operate. Testing of pickup, dropout, and timing of individual relays is not required, except for electromechanical relay models.

If available, a history of recent and previous trips of the main protective relays and initiation of the breaker failure protection may be the best demonstration of its reliability and assurance of the stability of the breaker backup scheme. This may allow delaying routine maintenance or reducing the number of tests to avoid potential risks involved in testing.

When testing other protective relays with the breaker failure protection in service, the breaker failure initiate signals from the protective relays should be properly isolated to prevent initiation of the breaker failure protection in order to avoid unwanted operation. Whenever possible, it is best to test both at the same time.

### 6.7.3 Test equipment requirements

Based on the tests described in 6.7.2.3, the test system should meet the following requirements:

- Be able to simulate the three-phase currents and voltages with the required number of states (prefault, fault 1, breaker opening time, dead-time condition (including any unbalances during one pole open condition), fault 2, postfault).
- Have a sufficient number of digital outputs to simulate the state of the breaker auxiliary contacts and protection trips to initiate BF.
- Have sufficient number of digital inputs to monitor the operation of all trips, retrips, reclose, and other important parts of the breaker failure protection scheme.
- Be capable of playing COMTRADE files for performance testing in order to simulate transient voltages and currents and to simulate digital outputs (with 0.1 ms resolution and accuracy).
- Be able to record and report all the test results, including the current and voltage waveforms, as well as the input and output digital signals, to provide a better picture and analysis of the entire test.
- Have the capability of synchronizing two or more three-phase test sets when required to test a protection system that has the main protection relays far away from the breaker fail relays.
- Use DFR, if available, to record the test sequences.

### 6.8 Reactor protection

Reactor protection has generally consisted of one or more protection functions. The protection type chosen is generally a selection based on the size of the reactor and importance of the reactor to the power system. Typical protection schemes include high-impedance current differential, current differential, phase overcurrent, negative sequence overcurrent, ground overcurrent, voltage unbalance, overvoltage, Volts/Hertz, and distance relays. In addition to specific functions provided by the relays, some reactors have a pole disagreement scheme to ensure all three phases are energized. Pole disagreement schemes can be provided through a combination of overcurrent elements and breaker contact logic. Reactor protection and control schemes may be integrated with an automated trip and insertion scheme to aid system operators

with the burden of managing system voltage. Refer to IEEE Std C37.109™-2006 [B24] for shunt reactor protection guide.

Testing of the reactor protection will be similar regardless whether it is a voltage control, current limiting, or a line reactor. The most thorough testing is completed at the time of energizing new equipment. The testing should include all the equipment that the relay is wired to or can be expected to impact. Because the relay action is based on currents and voltages, it is imperative that the relay input sources are tested and the performance characteristics of the sources (i.e., current transformers and potential transformers or CCVTs) are known. A wide range of simulation tests covering common to uncommon faults as well as various operating conditions should be performed. If the power system configuration or conditions will allow, all breakers energizing the reactor should be tripped at least once to verify the continuity of the trip path.

### 6.8.1 Reactor protection testing

The basis for a complete relay system test is to verify that the relays and control schemes respond as designed. Testing of the reactor protection system should verify relay settings and the control scheme action of the relay outputs.

Fault simulations should be applied to test operation of the protection systems of the reactor bank. The protection schemes employed are similar to the transformer protection and should be tested in a similar fashion. Special protection requirements such as a reactor without a breaker requiring a direct transfer trip to a remote breaker will require testing of the direct transfer trip systems. Other protection schemes include a sudden pressure relay generally disconnected on important load-carrying transformers.

If voltage control is implemented, then a range of voltage simulations should verify that the desired operating points are achieved and that hysteresis is provided to prevent cycling of the bank. For example, verify the reactor breaker opening angle is at peak voltage.

The simulations should be designed to test the relay systems at its expected operating boundaries. The test results should be documented and include verification of the following:

- Relay algorithm operation and operate times. This includes all protection used to protect the reactor bank.
- SCADA alarms.
- SER point operation.
- DFR triggering.
- Relay fault report triggering.
- Relay fault record retrieval.
- Relay targeting.
- Relay communications.
- Reactor breaker operation.

## 6.9 Generator protection

Generators are a key part of a power system. It is most critical that generator protection systems operate properly to clear faults and trip the machine for abnormal operating conditions. Refer to IEEE Std C37.102™-2006 [B21] for an ac generator protection guide.

Calibration testing is generally done with the generator offline. It is generally advisable to perform preventive maintenance of the generator protection system during scheduled unit outages. Most generators are on a 2- or 3-year outage cycle.

Table 5 presents typical generator protection functions that can be tested statically.

**Table 5—Generator protection functions**

ANSI function	Description
21	Backup distance
24	Overexcitation (V/Hz)
32	Reverse power
40	Loss of field
46	Negative sequence
51V	Voltage restrained overcurrent
50/27	Inadvertent energization
50 BF	Breaker failure
59	Phase overvoltage
59 N/27 TN	Stator ground fault protection
60 FL	Fuse loss
64 F	Field ground
81	Abnormal frequency
87	Phase differential

Wide area schemes that employ generator tripping should include that function in the testing of the overall scheme, preferably at times when the generator is offline.

The following elements will require phasing checks with the machine at some load level to allow checks of the phase angle between voltage and current: 21 V, 32 V, 40 V, and 51 V. It should be noted that many microprocessor-based generator protection relays will allow this check to be done using a computer connected to the relay, with the appropriate software, to allow the user to observe what quantities the relay is measuring. This precludes the need to use external equipment (phase angle meter, etc.) connected to test facilities (switches, blocks, etc.) to verify phasing.

In addition to static tests (minimum pickup, slope, etc.), differential elements should be tested according to IEEE Std C37.103-2004 [B22].

The preferred method to verify performance of the out-of-step protection function (device 78) is dynamic testing. If studies are available, it is also preferable to test loss-of-field elements (device 40) dynamically.

Extreme caution should be used when testing generator protection on a machine that has a generator breaker between the generator step-up transformer (GSU) and the transmission system to avoid unnecessarily tripping the GSU by any backup elements. Considering that there are different methods of terminating a generator to the power system, different protection and interlocking strategies are applied. For example, if the generator is unit connected, the GSU is connected to the generator and is likely shut down when the associated protection is being tested. When there is a generator breaker between the generator and the GSU, different zones of protection are often applied. In any case, the test procedures often incorporate considerations of any protection that overlaps with protection between the GSU and the power system. Some protection schemes may include breaker failure, bus differential and generator load reduction logic, and any trip blocking scheme that blocks generator protection from tripping switchyard breakers when the isolation device is open.

Testing of the lockout relays (LORs) associated with generator protection is common practice. Initial tests generally include allowing the LOR to trip all intended devices (generator breakers, field breakers, turbine stop valves, etc.). Some generator protective functions may perform some control action other than tripping the machine (e.g., volts/Hertz operates voltage regulator to reduce excitation) and should be allowed to perform this action at least on initial testing.

Reverse power protection can involve interlocks with turbine stop valve limit switches. Testing this scheme can include online testing, during which the turbine is tripped just prior to taking a machine offline, waiting for the stop valves to close and the machine to motor briefly, and then allowing the reverse power relay to trip the machine (of course, with an operator standing by in case the protection does not operate). This provides a good test of the overall operation of the reverse power protection as an entire scheme.

## 6.10 Trip circuit logic scheme

The trip circuit logic scheme includes the logic and circuits needed to trip the required breakers in a substation in order to clear a fault. In some cases, the reach of this scheme is not confined to the substation but also to the remote substations.

Typically, this scheme can be found in bus and breaker failure protection. When these two protections exist in the same substation, it is not unusual that the trip circuit logic scheme is shared.

Suppose in the breaker-and-half substation configuration of Figure 24 that a bus fault occurs on Bus I. The local bus protection detects the fault and trips all Bus I breakers. The trip circuit logic scheme selects the only breakers needed to clear the fault. Testing the scheme means to test the selectivity of only sending a trip command to the Bus I breakers and not to any other substation breakers. It also means to confirm that the trip path from the bus protection to each breaker is in good condition.

In the event that breaker A does not open because of a malfunction, the breaker failure protection will be requested to operate by retripping all Bus I breakers plus breaker B and sending an intertrip command to the remote Feeder 1 breaker.

The trip circuit logic scheme selects the backup breakers needed to clear the fault. Testing this scheme means to test the selectivity of only sending a trip command to Bus I breakers, to breaker B, and to the remote Feeder 1 breaker. It also means to test if the trip path from the breaker failure protection to each breaker is in good condition. The communication link from this substation to the remote substation of Feeder 1 plus the remote trip circuit also needs to be confirmed.

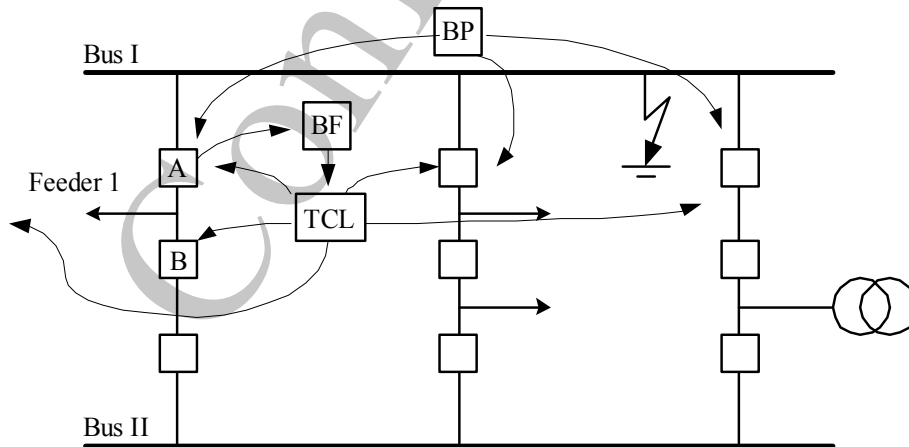

**Figure 24—Single-line breaker-and-half bus configuration with a fault on Bus I**

In a different topology like the one in Figure 25, which represents a double bus bar with bus coupler configuration, the bus protection decision of which breakers are needed to clear a bus fault depends on the substation layout at that moment. In substation layout of this figure, a Bus I fault is cleared by tripping the bus coupler breaker plus all feeders' breakers that are connected to this bus.

At the same time, a fault in Feeder 1 that is not cleared because of the breaker malfunction requires breaker failure action to be cleared. The breaker failure will trip the bus coupler and all the feeders' breakers that are connected to Bus II.

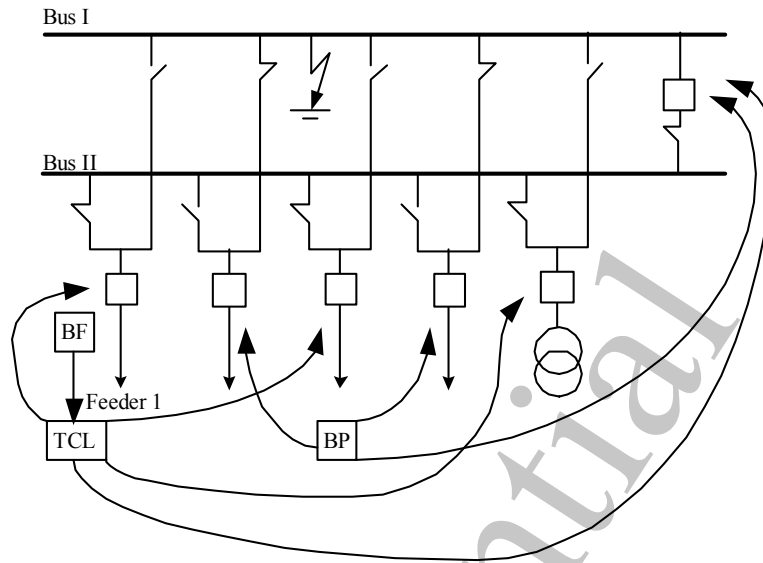
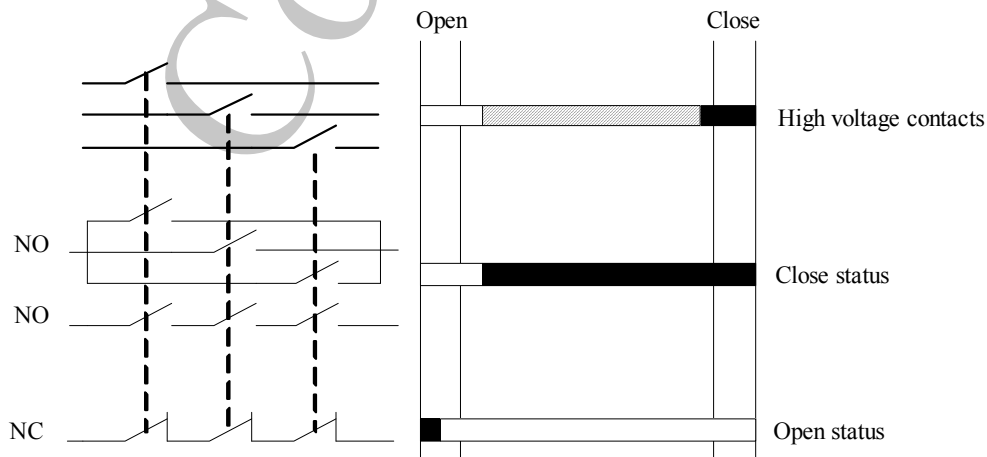

**Figure 25—Single-line example of a double bus-single breaker bus configuration with a fault on Bus I**

In both situations, the trip circuit logic contains not only the trip path from each protection, bus protection, or breaker failure protection, but also the substation replica to trip the required breakers selectively. The substation replica is achieved with the help of the isolators' and breakers' positions.

To achieve a high degree of security, for the isolators' position, information is needed on the open position and the closed position. For the open position, this information can be obtained using three normal close (NC) contacts in series. For the close position, it uses three normal open (NO) contacts in series or in parallel depending on the utility practice.

Figure 26 shows isolator replica status and its relation to the isolator movement.



**Figure 26—Isolator replica with normally closed and normally open positions**

Only when the opened and closed position agree, the isolator position is considered plausible. In case both disagree, different meanings for the isolator status can be chosen. Refer to Table 6.

**Table 6—Example of open and closed position definitions**

	Status		Meaning
	Opened	Closed	
Not plausible	1	1	Consider the isolator close. An alarm is given.
Loss of auxiliary voltage	0	0	Keep the old isolator position or consider the isolator close. In both cases an alarm is given.

### *Testing the trip circuit scheme*

Because of the large complexity of the trip circuit scheme, its testing should be first divided into separated parts before the overall final test. The scheme can be divided in three parts: a trip circuit, an isolator replica, and an overall scheme.

**Trip circuit**—It is the physical medium used by the protection to send a trip command to all possible breakers plus its correct operation. The physical medium typically is made of wiring but can be any other medium such as radio frequency, optical fiber, Ethernet, and so on.

**Isolator replica**—It is the correct acquisition of all isolators in the substation by the tripping logic and the proper processing of this information. This logic consists of a substation replica with the isolators' status as the input and/or output, the trip condition used by the bus protection, or the breaker failure scheme to activate trip command to the appropriate breakers.

**Overall scheme**—It is the combination of all parts working as a system.

### **6.10.1 Trip path test**

When testing the trip circuit, the integrity of the entire circuit from the protection output trip contact to the trip coils of all the breakers that are part of the respective scheme is verified. For bus protection, trip circuit testing of centralized or decentralized (distributed) bus protection schemes require proper functionality.

#### *Trip circuit in a centralized bus protection*

In a centralized bus protection, a number of trip outputs exist, one for each bus protection zone or one for each breaker. In Figure 24 and Figure 25, there are two buses; therefore, two protection zones exist, and consequently, the bus protection has at least two trip output contacts, one for each protection zone, or six trip output contacts equal to the number of breakers.

As part of the initial installation, trip circuit integrity verification can include operating the circuit breakers included in the bus differential zone. Complete trip checking includes activation of bus differential relay contacts to the corresponding breakers.

#### *Trip circuit in a decentralized bus protection*

In a decentralized bus protection, the protection consists of one central unit where most of the protection decisions are made, linked by optical fiber to a number of bay units spread along the substation panels where the current, isolator and breaker status are acquired. The trip outputs are also distributed along the bay units.

From each trip output contact in each bay unit to the corresponding breakers, the circuit integrity has to be checked, preferably by live opening of all breakers.

### *Trip circuit in breaker failure scheme*

In the breaker failure scheme, the trip circuit can be shared with the bus protection or it can be independent. In case it is shared, the testing is equivalent to testing the bus protection trip circuit. In case it is independent, a proper test to this circuit has to be done.

The circuit consists in the trip path from the breaker failure trip output contact to the device that contains the trip logic plus all trip circuits from this device to all breakers as shown in Figure 27. The integrity of these circuits has to be checked. The circuits connected to the breakers preferably should be checked by live opening.

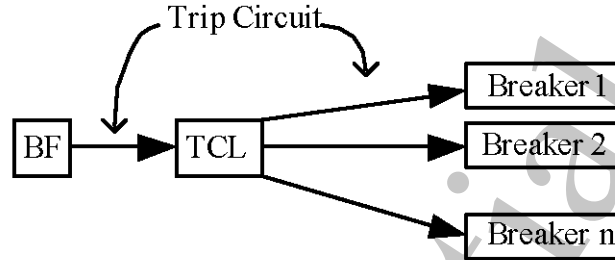

**Figure 27—A simplified diagram depicting breaker failure scheme independent of bus differential trip circuitry**

NOTE—At times, for maintenance or troubleshooting, the entire bus differential or the breaker failure scheme may need to be disabled depending on the scheme design. When the breaker failure trip scheme is part of the bus differential trip and lockout scheme, it is important to be able to isolate either the bus differential or the parts of the breaker failure scheme without completely removing the scheme out of service, to allow partial testing of the scheme while the remaining part of the bus differential remains functional and operational. Also, it is important that test personnel are aware of proper test methods so that isolated trip circuits do not remain energized for extended time periods when testing isolated circuits, as damage may occur to the part of the system under test.

### **6.10.2 Isolator replica test**

The isolator replica test consists of verifying that the isolator opening and closing status correctly arrives to the logic. For this purpose, a static test to verify simply that when the isolator position is open, the logic gets the open and not closed information, and when the isolator position is closed, it gets the not open and close information, is not enough.

The monitoring of these two statuses has to be done during the isolator closing and opening movements. This test prevents an alarm from being sent when, during the movement, the isolator is neither open nor closed. It also confirms that the auxiliary contact used to receive this information corresponds to the bus protection requirements. For example, the opening contact only occurs at the end of the close to open movement. Similarly, the close contact immediately appears in the beginning of the close to open movement.

### **6.10.3 The loss of voltage and the nonplausible situation also have to be checked**

That means this situation is correctly taken care of by the logic. For this purpose, the two cases need to be forced and their behavior has to be analyzed.

### **6.10.4 Overall test**

A final test is done to see that both trip circuits and the isolator replica are working as a system.



Ideally, this test should be performed by forcing the bus protection or the breaker protection to trip freely all correct breakers. When it is not possible to schedule an outage of the entire substation, it is common practice to isolate all the trip circuits at the last point that can be verified before the breaker coils.

For this, several substation configurations are simulated and for each of them the trip circuit logic is used by the bus protection or the breaker failure. All circuit breakers that were supposed to trip would receive a trip command from the logic, and at the same time, circuit breakers that were not supposed to trip would not receive a trip command. This last concern is important because it proves that the system has the desired selectivity.

## 7. Protection system communication testing

### 7.1 Power-line carrier testing

Power-line carrier equipment is used in many protection and control applications; refer to IEEE Std 643™. The most common applications include pilot transmission-line protection, such as blocking or unblocking schemes, direct transfer tripping, and phase comparison. Other less common applications include voice and data traffic in addition to protection, based on the bandwidth a trap is designed for, or the type of coupling (single phase or multiple phase) to the transmission line. For the purpose of system testing, the following discussion covers single-phase coupling. The same techniques are used in phase-to-phase and three-phase coupling.

The types of tests covered in this clause include the following:

- Line trap
- Carrier transmit measurement terminated and bridged
- Carrier receive measurement terminated and bridged
- Measurement specification
- Amplifier impact of power-line carrier testing

#### 7.1.1 Line trap

This test requires the transmission or distribution line to be deenergized. Figure 28 shows a typical test setup. The trap tuning (resonant frequency set point) is verified by checking impedance versus frequency. In Figure 28, the center frequency is tuned to the maximum impedance, which is measured using the impedance meter and signal generator. When verifying the trap frequency set point or points, it is best to use the highest impedance possible for the used spectrum. The typical minimum impedance value for wide band traps is 600  $\Omega$ . For single-frequency traps, the acceptable minimum impedance value may be 1000  $\Omega$ . These ohmic values are examples. The manufacturers' instruction manuals provide the minimum acceptable impedances.

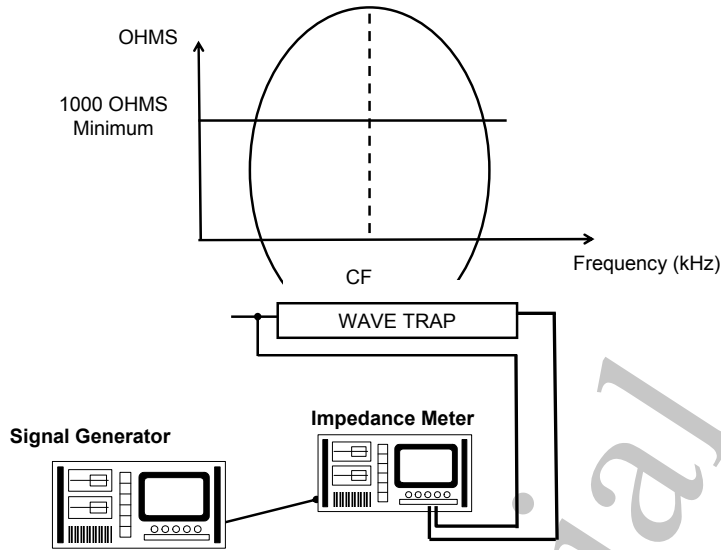

**Figure 28—Power-line carrier wave trap frequency set point verification**

Table 7 describes the general connection terminals between test and measurement equipment.

**Table 7—Typical connection terminals between test and measurement equipment for wave trap frequency set point verification**

Wave trap frequency set point verification connections		
Signal generator output (high-level very low frequency (VLF) signal source]	Impedance magnitude (level) meter	
Reflected frequency (RF) out	Signal input from the RF generator	High-impedance inputs (Hi Z and Gnd) Connected to wave trap

### 7.1.2 Carrier transmit and receive measurement terminated and bridged

This test verifies that the transmitted power from the power-line carrier equipment is efficiently coupled to the line. The test measures the standing wave ratio (SWR) and/or the reflected power. Note that the ratio mismatch would be excessively high and recognizable for defective or poorly adjusted equipment. It is possible not to achieve a precise 1:1 ratio match, for example, for multitap transmission lines. Also, care should be exercised for multitap transmission lines at the tap points to allow signals not to be attenuated excessively at the tap point and for the signals to get through to all the remote station terminals of the line.

In the transmit mode, the test equipment is connected to the carrier transmitter, as shown in Figure 29. In the bridge test, the impedance matching transformer of the line tuner is used to match the impedance of the carrier equipment to the impedance of the line. These measurements generally identify the types of problems that can produce improper readings, such as failed coax cable, misadjusted line tuner, or failed component. Also, it is important to verify on either side of the frequency spectrum in the case of hybrid arrangement.

With the carrier receive test, the signal level received from the remote terminal is verified. In the receive mode, the test equipment is connected to the line tuner.

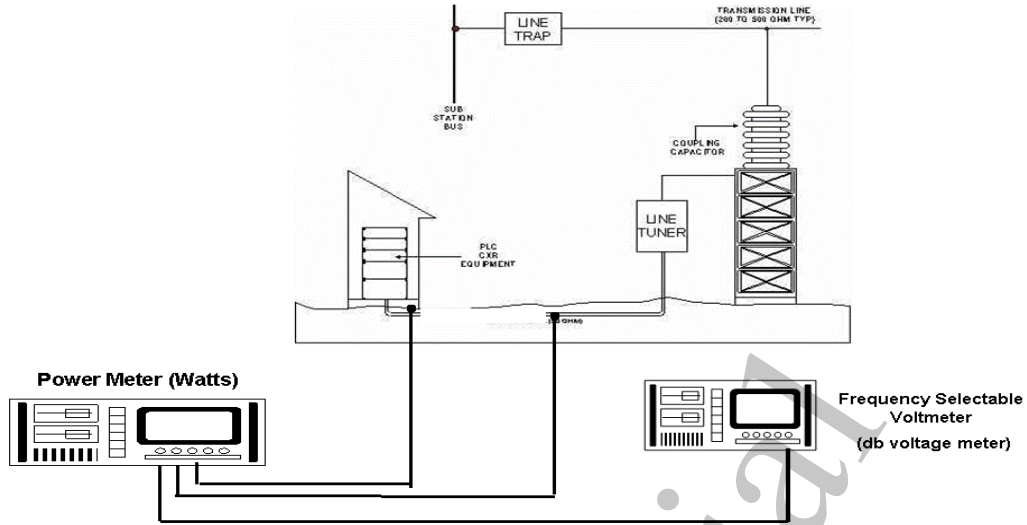

Figure 29—Setup for power-line carrier testing—equipment setup for transmit test (bridged) reflected power and SWR

Table 8 describes the general connection for measuring the power-line carrier transmit signal.

Table 8—Typical connection for measuring and testing transmit frequency for Figure 29

Set-up transmit measurement using automatic VLF power standing wave ratio (SWR) test set			
SWR meter		Frequency selectable voltmeter	
Voltage sampling coaxial terminal (e.g., -20 db signal)			Internal attenuator
RF in	PLC output		
RF out (transmitter)		Line tuner input	

#### The proper connections

As is the case for any type of test, proper connections and verification prior to turning on any test equipment are critical. In the case of power-line carrier measurement test equipment, it is also important to realize that at times power amplifiers may be used or to be aware of equipment limitations to minimize potential damage to equipment or the calibration of the test sets. For example, the user should be careful to connect the PLC transmitter output to the **SAMPLE -20 dB** connector in the case of the SWR meter. In most cases, this output port can only tolerate a small power (in the range of 100 mW) before blowing a protective fuse. Once the fuse is blown, the sample port becomes inoperative and the voltage sample feature is lost until the fuse is replaced. Damage to the instrument may be limited to the blown fuse if a protective fuse is provided.

#### 7.1.3 Example for typical measurement specification for protection communication using power-line carrier

The following values illustrate the types of frequency ranges for different power-line carrier applications:

- Permissive carrier output = 10 W or +40 dbm
- Blocking carrier output = 100 W or +50 dbm

- c) Carrier receive level = 1 W or +30 dbm
- d) Percentage of reflected power = 5% (or SWR of 1.6:1)
- e) Wavetrap impedance 1000  $\Omega$  at carrier frequency.

These numbers are examples only. The maximum permissible PLC can be 100 W, the minimum line trap impedance can be less than 1000  $\Omega$ , and the maximum reflected power of 5% may be difficult to obtain on short lines, maybe closer to 20%.

For multiple signals coupled to the same line or to different phases (multiphase coupling), additional tests may be needed to determine that a given receiver is not subject to interference from other signals and to validate proper frequency selection. Additional interference may be caused by other carrier transmitters connected to adjacent lines connected to the bus or on the same right of way. Interference from a parallel circuit on the same tower is a notable example. Misadjusted or failed traps can cause elevated levels of interference to other carrier channels, as well as the reduction of the signal strength at the intended receiver.

## 7.2 Functional testing of IEC 61850-based substation automation systems

Distributed protection applications are being implemented based on high-speed peer-to-peer communications defined initially in UCA2 and now part of the international standard IEC 61850. Testing of distributed protection applications and protection functions that participate as “publishers” or “subscribers” are quite different from what was traditionally used in the conventional world of testing.

The testing issues are further complicated by the fact that there are different types of data being communicated that need to be considered, simulated, and monitored:

- Client/server communication (IP traffic/multimedia messages)
- Real-time communication, event-driven [GOOSE, (GSSE)], also referred to as substation bus (IEC 61850-8-1 [B12])
- Real-time communication, periodic (sampled values), also referred to as process bus (IEC 61850-9-2 [B15])

The test procedures for IEC 61850 protection applications will assume that the tested devices conform to the standard and should concentrate on the functional testing, including the following:

- Functional testing of IEC 61850-compliant protection microprocessor-based devices
- Functional testing of bay-level distributed protection applications
- Functional testing of substation-level distributed protection applications
- Functional testing of protections requiring remote terminal information (two-ended)

One of the key advantages of IEC 61850 is that it delivers not only a set of data models with predefined semantics and a number of application specific protocols, but also it is a new approach to engineering, which (if fully implemented) allows automatic configuration of test plans for local and distributed functions. This will be based on the availability of the various files defined in the substation configuration language (SCL).

### 7.2.1 IEC 61850 system testing

In the course of linking IEC 61850 object models together through logic and GOOSE communications, there is a need to be able to test the functionality of the resultant system. IEC 61850 defines several “test” modes; however, the interaction between the test modes and GOOSE communications is not defined. This subclause proposes a test and response methodology when using the test modes defined in IEC 61850.

### 7.2.2 IEC 61850 data organization and test modes

IEC 61850 organizes information in a device through the concept of logical nodes (LNs) and logical devices (LDs). An LN is the “smallest” entity in which data is organized and is typically designed around a specific function such as an overcurrent element (PIOC, PTOC) or a distance element (PDIS). As a number of LNs are required to perform a specific protection or control function, LNs performing an ensemble of functions can be grouped into an LD.

Each LD and LN has a data item called “behavior.” This data item describes the “operating mode” of the respective LD or LN. There are five states of behavior that can describe a device, as follows:

- OFF—the LD or LN is out of service.
- ON—The LD or LN is in service.
- Blocked—the LD or LN is in service but blocked from issuing an output.
- Test—the LD or LN is under test.
- Test and blocked—the LD or LN is in test mode and all outputs are blocked.

Note that when the behavior of an LD is changed, all LNs that are part of that LD inherit the changed behavior of the LD. When an LD is placed in test mode, the test bit in the quality flags of all data attributes are to be set to test. Likewise, if the LD is placed in Test and Block mode, both the test and the block quality flags for all data attributes are to be set in all LNs contained in the respective LD.

Each LN can individually be placed in test or test and blocked mode. As such, the quality flags of all attributes in that LN should have their test and/or blocked quality flags set.

### 7.2.3 Mapping of test status into GOOSE

If a data attribute that is in test or test/blocked mode is mapped into a GOOSE message, then the test bit in the transmitted (published) GOOSE message is to be set. A device receiving (subscribing) a GOOSE message with the test bit set is to respond in one of two ways, as follows:

- When the receiving device is not in a test or test/blocked state and a test mode is initiated, all LDs in the device can be configured to transition automatically to the test/blocked mode of operation. In this mode, no outputs are issued and the test and blocked bits in any quality flag are to be set.
- When the receiving device is in either test or test/blocked mode, the receiving device is to respond as per its setting. For example, when the receiving device is in test mode, any outputs resulting from the received GOOSE message are to be issued—with the corresponding test bit set in the respective quality flags. Similarly, if the receiving device is in the test/blocked mode of operation, the receiving device shall execute any logic. However, any outputs resulting from the execution of the logic are to be blocked from issuing an output. Additionally, the respective test and blocked bits in any data quality flags are to be set.

### 7.2.4 GOOSE performance testing

IEC 61850 defines GOOSE performance based on internal timings of a device. However, IEC 61850 does not define methods for performance testing. In order to make the performance measurable, a back-to-back GOOSE Echo test is proposed. In this test mode of operation, relays of the same manufacturer and relay type are to be connected back-to-back through an Ethernet switch (see Figure 30). Relay 1 is to send a GOOSE message to relay 2. Relay 2 is to receive the message and immediately “echo” the message back to relay 1. Another alternative is to use a test set capable of publishing and subscribing to GOOSE messages, for performance testing of a relay. GOOSE performance time is defined as follows:

$$\text{Performance} = (t_{\text{GOOSE\_In}} - t_{\text{GOOSE\_Out}}) / 2$$

GOOSE has been designed with explicit sets of timing requirements as a benchmark for performance. Delays can be caused by improper switch configuration that does not include prioritization of GOOSE message. Excessive network traffic is often monitored in order to determine the adverse impact on the application of the GOOSE messages.

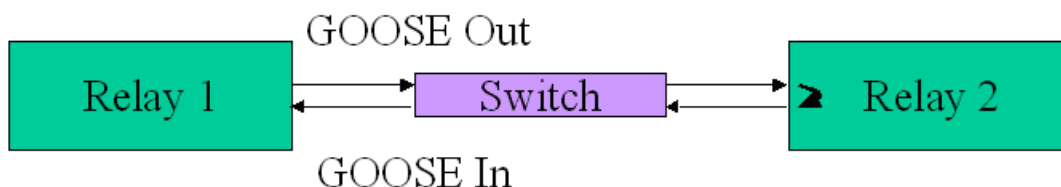

**Figure 30—GOOSE performance test**

### 7.2.5 Configuration requirements for testing of distributed protection applications

One of the key requirements for testing of IEC 61850-based protection devices and distributed applications is verification of interoperability. Interoperability is defined as the ability of two or more microprocessor-based devices from the same or different vendors to exchange information and use that information for correct internal/external operation. For a device to be acceptable for integration in an IEC 61850 system, it first has to be properly type tested. This will verify that it is compliant with the definitions of the standard and will likely interoperate with other certified microprocessor-based devices in the system.

Before the functional testing of a device or distributed function is started, they need to pass the conformance tests defined in the standard (Part 10 of IEC 61850 defines these requirements). Part 6 of the standard defines the SCL and provides some tools that can be very helpful in performing automatic functional testing. One difficulty is to determine the functionality of the tested device and its configuration (which functional elements are enabled and what are their settings). Help in automating this process will result in significant time savings.

The SCL is basically a system specification of the substation equipment connections in a single line diagram. It also documents the allocation of logical nodes (functional elements such as overcurrent and distance) to devices and equipment of the single line to define functionality, access point connections, and subnetwork access paths for all possible clients.

What is of specific interest for the automatic test configuration is the data exchange among the system configuration tool, the tested microprocessor-based device configuration tools, and the test system configuration tool shown in Figure 31.

The overall functionality of any IEC 61850-compliant device is available in a file that describes its capabilities. This file has the extension ICD, meaning intelligent electronic device (IED) capability description. The system specification tool supplies to the system configuration tool information such as the single-line diagram of the substation and the required logical nodes. The file extension for this file is SSD, meaning system specification description.

The system configuration tool then provides information to the microprocessor-based device configuration tools regarding all microprocessor-based devices, communication configuration, and substation description sections. This information is in a file with the SCD extension, meaning substation configuration description. This information also needs to be provided to the functional testing tools in order to allow it to configure the set of tests to be performed.

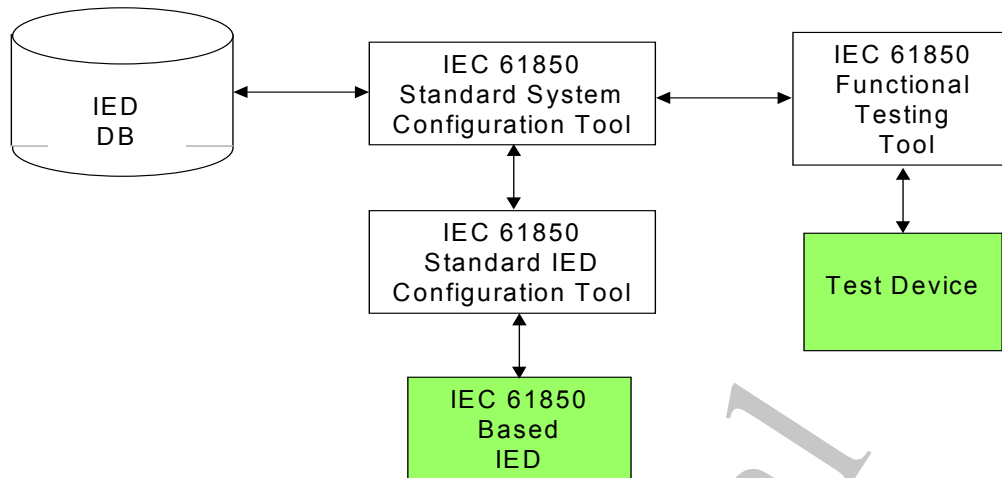

**Figure 31 —Functional testing configuration process**

The IEC 61850 configuration tool sends information to the microprocessor-based device upon its instantiation within a substation automation system (SAS) project. The communication section of the file contains the current address of the microprocessor-based device. The substation section related to this microprocessor-based device may be present and shall have name values assigned according to the project-specific names. This file has an extension of CID, meaning configured IED description. Additional standards are needed in order to expand the content of this file to include all settings, thus providing the required configuration data for the microprocessor-based device itself and for the functional testing tool.

All the information on the substation, SAS, and microprocessor-based device configuration are required to configure the test procedures properly for the functional elements and local/distributed protection functions. However, even this is not sufficient for automating the process. Another important requirement is to provide test cases on how each of the functional elements or local/distributed functions should be tested and what is the expected behavior of the test object under defined test conditions.

Based on this information and the system/microprocessor-based device configuration data, a functional testing tool can generate and execute the necessary test sequences. Such a formal definition of the test cases for the functional elements and other complex functions is not part of the standard today. Making functional test case definitions part of the standard will require a significant effort, but it will allow the development of new tools for automatic functional testing of IEC 61850-based microprocessor-based devices and SASs.

### 7.2.6 Functional testing of IEC 61850-based applications

The testing of conventional functions in substation protection and control systems has some similarities and some differences with the IEC 61850 communications-based solutions. In the case of the conventional testing, the test device has to simulate the substation process using a hard-wired interface between the analog and binary outputs of the test device and the analog and binary inputs of the test object. A typical test process requires the test device to output a simulation or event that will trigger a measurable response from the test object. The timing of the test object's input/output change-of-state events for defined test cases determines proper operation.

By comparison, communications-based distributed functions utilize the IEC 61850 GSSE or GOOSE messages replacing the hard-wired connections. In the case of Figure 32, all devices with communications interface have to be connected to the substation network switch to exchange data.

The expected communications-based performance should be similar to the conventional hard-wired interface; it is a good idea to include a test case that compares the operation of a wired relay output and a GOOSE message driven by the same functional element in the microprocessor-based device logic.

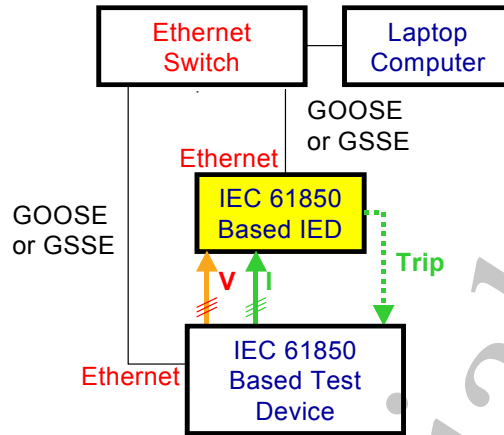
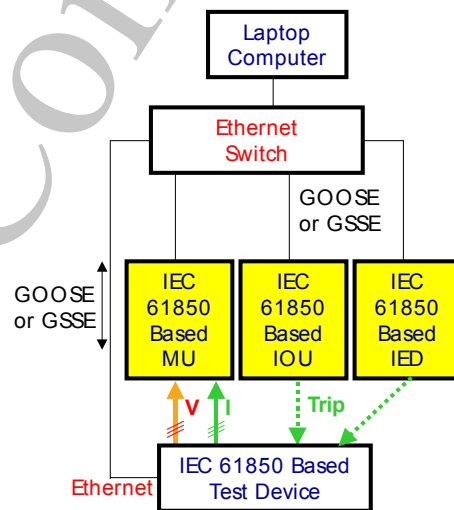

**Figure 32—IEC 61850 GSSE- or GOOSE-based microprocessor-based device (IED) functional testing**

Another difference between the conventional testing and the IEC 61850 GOOSE-based functional testing is the requirement for the change-of-state process simulation using GOOSE messages from the test device to the test object. An example is to indicate the opening of the auxiliary contact 52a of the circuit breaker monitored by the microprocessor-based device under test.

Distributed protection applications based on IEC 61850 merging units (MUs) that send sampled values over the substation LAN will need a test setup similar to the configuration shown in Figure 33.

In this case, the analog signals from the test device will be wired to the MU. The distributed function will be performed by the IEC 61850-based microprocessor-based device that will send a GOOSE message to an IEC 61850 input/output unit (IOU) that will operate a physical relay output to trip the circuit breaker. The test device will subscribe and capture this message and also detect the operation of the binary output of the IOU. It monitors different elements of the distributed function and can analyze their performance, as well as the system's overall operating time.



**Figure 33—IEC 61850-based microprocessor-based device functional testing results**

If the tested IEC 61850-based microprocessor-based device also has a binary output, the test device can monitor it as well. This can provide valuable information in the overall evaluation of process performance.



The binary output of the IOU interface unit will give the total distributed protection function operating time for the case of a complete IEC 61850 communications-based solution.

## 7.3 Wireless communication

### 7.3.1 Wireless data link testing

The increase in the growth of information and communication technology (ICT) is raising the penetration of wireless communications units based on global system for mobile, general packet radio service, and low earth satellites-based technologies in power systems.

These communication units provide real-time, low-cost, bidirectional data-exchange solutions for power system communication. In particular, they could support several tasks of SCADA applications for electric utility industry use, such as the following:

- Capture polled, scheduled, and event-driven data
- Report on power outages
- Monitor or remotely control the following:
  - 1) Capacitor bank monitors
  - 2) Voltage regulators
  - 3) Power components
  - 4) Load management

Communications services employed to support these tasks handle, typically, the following two kinds of data connections:

- Packet: over the Internet or other TCP/IP packet-switched networks
- Asynchronous: routed through the public switched telephone network (PSTN) to a modem destination

In packet data mode, the communication unit lets the application device (i.e., the protective system or the microprocessor-based device) originate or receive a “packet data call” via standard AT commands. It establishes a peer-to-peer protocol session, connects to the Internet, and then establishes a session with a host server.

In asynchronous data mode, the communication unit lets the application device originate or receive an asynchronous data call. It can dial or be dialed to a modem at the host server, connecting through the wireless communications system and the PSTN.

### 7.3.2 Testing procedure

To evaluate the suitability of a wireless communication unit to support the designed protective and monitoring functions set, it is necessary to evaluate the main figures of merit characterizing the communication data link performance.

They comprise, in particular, the connection times, the degradation of services, and the data latency. To evaluate experimentally these parameters, it is necessary to do the following:

- a) Install the device under test in the substation

- b) Submit multiple queries to the remote device by a host server
- c) Measure the characteristic parameters

### 7.3.2.1 Connection times evaluation

Regarding the connection times, the communication protocol involves several activities once a module originated packet data call is set up. They comprise, typically, the system setup, the physical layer setup, the encryption, and the service option negotiation. Several field trials should be necessary to assess this parameter.

### 7.3.2.2 Degradation of service

As far as the degradation of the service, the frame error rate (a measure of the radio link quality) should be evaluated.

### 7.3.2.3 Data latency

The data latency is the time delay caused by getting a network message from the host server to the remote DUT and getting a response back again. This time delay can be made larger by the following processes:

- Propagation delay
- Transmission delay
- Router delays
- Packet loss, recovery, and retransmission

The data latency of the data link could be estimated measuring, for a fixed time period, the packet round-trip times at the transport level of the ISO/OSI stack. In this connection, it is important to underline that this value is expected to be highly random because it is influenced by several drive factors, such as communication links congestion, communication protocols, and data link quality. To deal with these phenomena, the worst-case scenario, characterized by higher expected levels of data link congestion, should be considered for the measurements.

## 8. SIPS test requirements

System integrity protection schemes (SIPS), which are also called RASs or SPSs, serve to ensure security and prevent propagation of disturbances for severe system emergencies caused by unplanned operating conditions. They stabilize power systems for equipment outages related to N-2 criteria or beyond by preventing overloading of the lines, arresting voltage decline, initiating preplanned separation of the power system, and so on. System integrity protection schemes, armed for predefined outages, initiate preplanned, automatic, and corrective actions. Their design is based on studies of predefined outages for a variety of conditions.

Figure 34 shows the overall structure of a scheme, comprising input facilities, electric, and status variables; a decision process; and output action orders.

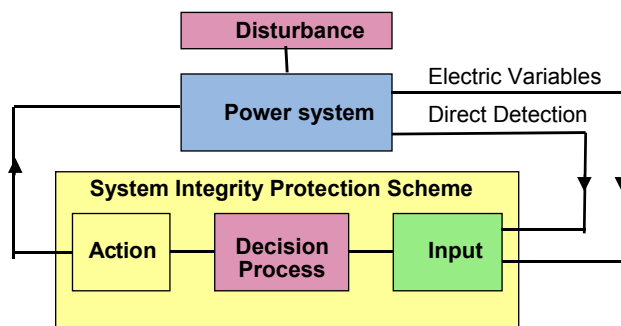

Figure 34—Simplified overview of SIPS structure

Figure 35 shows a typical architecture for a wide area scheme. Depending on the intent of the scheme, several control areas or systems may be interconnected.

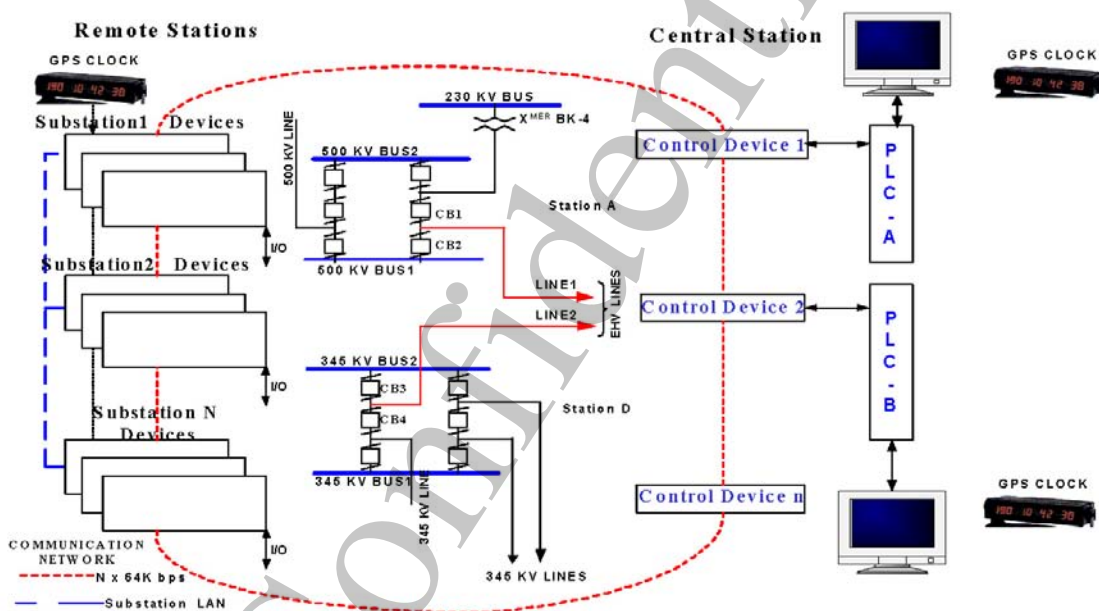

Figure 35—Physical architecture of a redundant SIPS

Such schemes are complex due to the following reasons:

- Selection of various equipment
- Identification of monitoring points
- Types of alarms and priority classification
- Various contingencies associated with equipment abnormal conditions
- Types and availability of real-time data
- Considerations for various categories of inputs and output tests
- Development of the test scenarios, coupled by provisions for automated testing

Furthermore, wide area protection schemes may involve many different entities with different backgrounds and practices.

This complexity requires very stringent and detailed test procedures to confirm both security and dependability of those schemes.

#### *System variables*

Depending on the purpose of the SIPS, different quantities have to be derived at different speed and accuracy levels. On the one hand, to counteract certain disturbances (e.g., to prevent loss of synchronism), remedial actions have to be effective within fractions of a second. On the other hand, actions against thermal limitations or long-term voltage instability can be allowed to take more time, seconds to tens of seconds.

In preparing for test setups, the test coordinator and the test program need to consider the various elements of the SIPS design, including utilized variables. The variables can be either directly measured (such as voltage level, frequency, power flow, and current) or derived from the measurements using more or less complex algorithms.

A more general variable set is achieved from a power system state calculation, based on complete observability by PMUs, from which any type of index can be derived. Also, faster than real-time simulations, based on the state calculation, may be possible.

Below are some examples of input variables for various applications.

#### *Measurement inputs*

- Power system voltages
  - 1) Voltage—synchronized to local measurements in the same substation
  - 2) Voltage—wide area synchronized
  - 3) Voltage phasors (i.e., magnitude and phase angle)
- Power system currents
  - 1) Current—synchronized to local measurements in the same substation
  - 2) Current—wide area synchronized
  - 3) Current phasors (i.e., magnitude and phase angle)
- Control signals
  - 1) Continuous
    - i) Generator/synchronous condenser AVR
    - ii) Generator PSS (power system stabilizer)
    - iii) Generator governor
    - iv) HVDC converters, SVC, FACTS, TCSC, D-VAR, etc., controllers
  - 2) Binary
    - i) Increase/decrease, according to the following predecided steps:
      - A) Transformer tap changer
      - B) Tie-line transfer
      - C) Reactive power compensation

- ii) Trip/close: circuit breaker (line disconnect, generator rejection, load shedding, etc.)
  - iii) Relay protection trip order
- Status
- 1) Circuit-breaker position
  - 2) Tap-changer position
  - 3) Generator field current limiter activated
  - 4) Generator armature current limiter activated
  - 5) Predefined thresholds reached
  - 6) Various alarm signals
  - 7) Relay protection start signals
  - 8) Disturbance recorder start signals

#### *Types of tests when implementing SIPS*

The ultimate success of the implementation solution depends on a proper testing plan. Each application would need to be evaluated on a case-by-case basis. It is advisable to create a detailed test plan as part of the overall implementation. A combination of the logical architecture, logic design, and the physical architecture could be used in preparation of the test plan.

The complexity of the scheme, its purpose, space availability, and other factors may drive some of the decisions associated with the scheme applied and the levels of tests to be performed. A proper test plan should include the following components:

- Proof-of-concept/laboratory testing
- Field commissioning testing
- Detailed system-wide performance testing
- Validation through state estimation
- Automatic and manual periodic testing of the entire scheme

### **8.1 Proof-of-concept testing**

Prior to the implementation of the design, proof-of-concept (laboratory) testing is practiced to evaluate the performance and functionality of the scheme and to determine whether additional developments are needed to meet the desired specifications. Laboratory testing is designed to validate the overall scheme in a controlled environment. Laboratory tests permit controlled inputs from numerous sources with frequent checks of the output at every stage of the testing process. The laboratory tests ensure that the desired results are accomplished in the laboratory environment in contrast to costly and time-consuming field debugging.

For example, in a group of three devices, a laboratory test could be simulated to check wide area communications (fiber, copper, and Ethernet), average message delivery and return time, unreturned messages count and CRC failure count (under simulated noise conditions), and back-up communication switching timings.

## 8.2 Field commissioning tests

Field commissioning tests should be carried out to check the performance of the SIPS against the realistic abnormal system conditions. The telemetry data and the dynamics of various power system configurations need to be tested. Examples are as follows:

- Breaker close and bypass contacts
- Changing the selectivity of the current transformer inputs
- Total trip timing over the implemented communications between devices and the central control station
- Possible scenarios of unavailability of devices at the time of execution of a command signal in a given station

In general, every input point and every logic condition needs to be validated against expected results. Additionally, the effect of dc transients on line outage needs to be tested thoroughly in the field before putting the scheme into service.

## 8.3 System-wide performance testing during maintenance intervals

Proper implementation requires a well-defined and coordinated test plan for performance evaluation of the overall system during agreed maintenance intervals. The maintenance test plan, also referred to as functional system testing, should include inputs, outputs, communication, logic, and throughput timing tests. The functional tests are generally not component-level testing, rather overall system testing. Some of the input tests may need to be done ahead of overall system testing to the extent that the tests affect the overall performance. The test coordinator or coordinators need to have full knowledge of the intent of the scheme, isolation points, simulation scenarios, and restoration to normal procedures.

The concept is to validate the overall performance of the scheme, including the logic where applicable, to validate the overall throughput times against system modeling for different types of contingencies, and to verify scheme performance as well as the inputs and outputs.

The overall system testing may include electrical supervisory provisions from a central dispatch for added security. Some key elements of test setup are as follows:

- Test units' connectivity to the devices with communication interface for communicating with the field devices
- Supervisory process (dispatch permission)
- Test signal (test person)
- Frequency, voltage, and other power system conditions that need to be simulated
- Outages (input test)
- Trips (output tests)
- Enable/disable functions of the field devices
- Automatic restoration enable/disable
- Functional tests
- Overall timing results

Figure 36 shows an example of a simulator system setup for testing redundant controllers A and B. Once overall performance tests for various scenarios are completed on one system, the simulator can be utilized for the redundant system (B) performance testing. Other test methods are possible; for example, once a particular scenario is completed on system A, the test coordinators repeat the test on system B to compare performance between the two systems and administer any corrective actions.

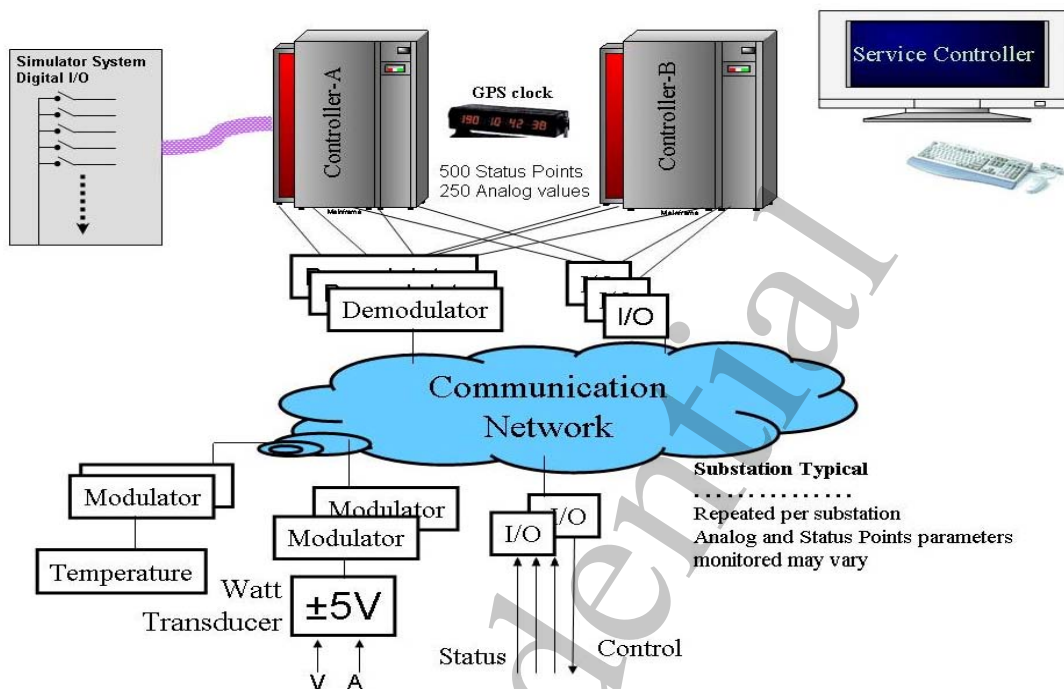

**Figure 36—Simulator setup for testing a redundant SIPS**

The overall functionality of the SIPSs is validated against the system studies. The total throughput of the system during commissioning and scenario testing stages should measure significantly less than the throughput time identified in systems studies to allow for system changes and in case other stringent contingencies are identified in the future.

#### 8.4 Validation through state estimation

For schemes that involve transmission constraints and stability limits, data from the state estimator can be used to determine different preoutage flows within the power grid. The preoutage flows are loaded into the controller as precontingency conditions. The controller, or simulator portion of the controller, would then be programmed for various outage, underfrequency, and/or undervoltage status scenarios to perform overall system performance evaluation.

State estimator data could also be used to develop case scenarios representing future flows and load patterns for further system performance evaluations or to make adjustments where necessary.

#### 8.5 Automatic and manual periodic testing of the entire scheme

Maintenance engineers should have a library of system-wide test cases. A proper test plan to simulate line outage on the monitored transmission/distribution lines in the respective substations and tripping of the

lines should be conducted on a periodic basis to test the contingency plans and as a learning curve for the better understanding of the SIPS application.

Those tests should be conducted without disabling any inputs. Only trip output contacts or auxiliary tripping devices are disabled opening (isolating) the trip or possibly the close path (in case of capacitor bypass or reactive insertion).

A critical consideration in implementing wide area monitoring and control schemes is the development of automated test scenarios. Such test cases could be prepared based on the type and the intended application of the scheme, and these tests should include provisions for ease of updating case studies as system conditions change.

Technology advancements in communication and computers have provided opportunities to simplify implementation of wide area protection and control systems. Computer-based devices can communicate power system information both with central controllers as well as with each other. This in turn facilitates the deployment of overall system-wide protection and control schemes. With an information infrastructure, it is possible to connect all the monitoring, control and protection devices together through an information network. An example of such a scheme is shown in Figure 37.

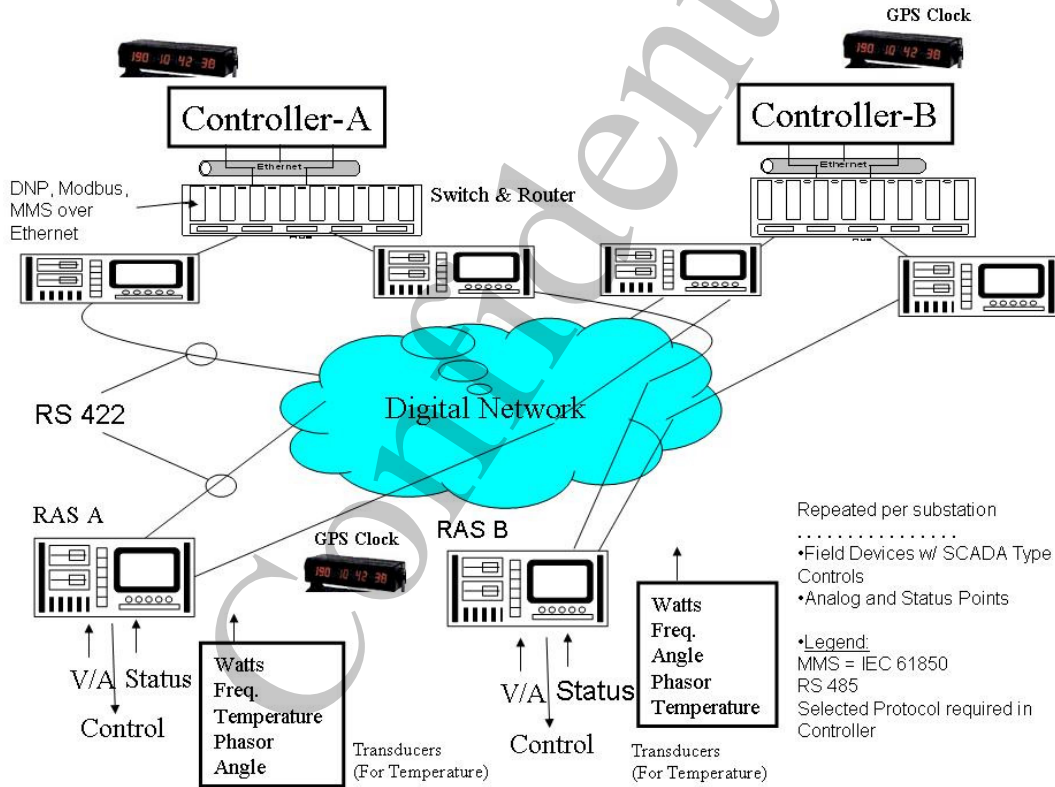
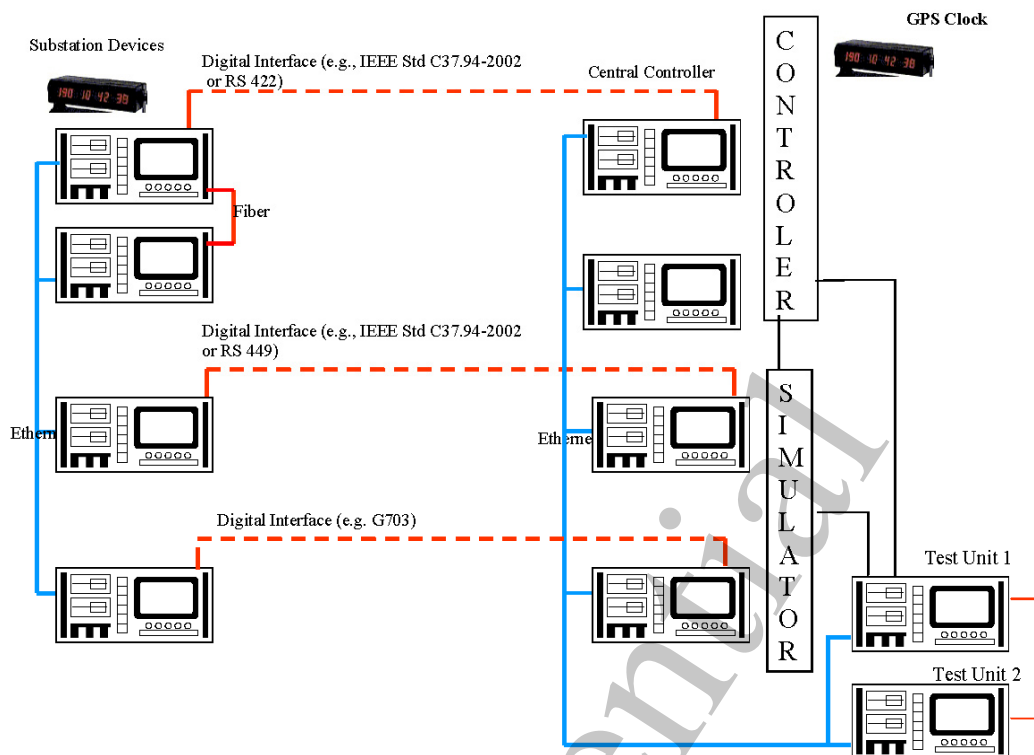

**Figure 37—Redundant SPS or RAS system with central controllers at different physical locations with different communications interface/protocol options**

*Using peer-to-peer connectivity*

A typical test setup to test overall performance and throughput timing measurements is presented in Figure 38. The test units and simulator are connected to the controllers to test a scheme shown in Figure 38.





**Figure 38—Typical test setup for overall performance testing and throughput timing measurements**

In conclusion, overall system performance tests and automated and intelligent system testing need well-developed test plans. These tests may require the scheme to be unavailable during tests while the redundant system continues to provide the safety net.

## 9. Testing protection and control systems with unconventional voltage and current sensing inputs

### 9.1 Testing inputs to relays and microprocessor-based devices with low-level analog inputs per IEEE Std C37.92™-2005 [B19]

The purpose of IEEE Std C37.92-2005 [B19] is to define a low-level standard interface between relays and unconventional sensors that cannot easily generate the high-level signal outputs like those of familiar CTs and VTs. The sensors are typically designed with analog electronic signal generating circuits operating at less than  $\pm 15$  V and delivering signals to relatively high-input impedances of electronic circuits in the relays. Other types of sensors, such as Rogowski coils, have passive low-energy outputs that are also compatible with these same high-impedance electronic inputs. This clause discusses testing of the *relays and their inputs*. Testing the *sensor outputs* is covered in IEEE Std C37.92-2005 [B19].

Relays and other microprocessor-based devices with low-level analog inputs per IEEE Std C37.92-2005 [B19] are typically microprocessor based, with analog electronic input circuits interfaced to analog-to-digital converters. Beyond the low-energy input circuits for voltage and current signals, these relays are identical to those designed for conventional instrument transformer secondary signal inputs of 69 V or 120 V and 5 A. The overall functional testing or verification strategy is the same.

Instrument transformer standards IEC 60044-7 [B9] and IEC 60044-8 [B10] specify similar types of low-level interfaces for voltage and current signals, although these standards list several normal values in lieu of a single standard value. The testing approaches are the same.

The major design difference is that the input isolating transformers are wound differently (or deleted entirely) for the following reasons:

- The relay has a high-impedance input (50 000  $\Omega$  typical) and accepts a low-energy signal of about 200 mV RMS to represent a primary current corresponding to 1 per unit primary load. This is scaled so that the instantaneous peak of a 20 per unit fault current fully offset will be slightly more than 11 V and within amplification range of commonly used operational amplifier circuits.
- The relay has a high-impedance input and accepts a low-energy signal of about 4 V RMS to represent a primary voltage of 1 per unit.

It is important to note that with this type of low-level interface, primary current signals are represented by a voltage signal. This is fundamentally different from conventional relays, whose current inputs require a CT secondary current proportional to primary power system current.

Such a relay can be tested via injection testing methods that are used for conventional relays, except that the signals must be scaled to these lower standard levels and the current input signal must be converted to voltage across a burden resistor. If the test set is based on microprocessor or computing technology, the modification may include removing or bypassing the power amplifier needed to drive conventional relays needing large signal inputs from the low-level electronic signal sources in the test set.

It is easy to test these relays using a conventional relay test set with a simple transformer-based adaptor. Transformers and interface circuits similar to or exactly like those installed in the front end of a conventional microprocessor relay can be used to build the adaptor. The normal voltage signal of 69 V RMS is scaled with a small wound transformer or a resistive divider to the 4 V signal used by the relay with IEEE C37.92-2005 [B19] voltage interface. The 5 A current signal is passed through a small current transformer with a resistive burden, such that the voltage developed across the burden is 200 mV. Alternatively the test set 5 A current output can be directly connected to a 40 milliohm burden resistor, if such an accurate burden resistor is available. It is similarly easy to scale signals to several of the many alternative low-energy signal levels given in IEC 60044-7 [B9] or IEC 60044-8 [B10].

Test signals for a relay having this interface are also easy to generate with a personal computer and a low-level electronic analog output—even a small electronic amplifier connected to a sound card could produce adequate energy to simulate faults. Real-time digital simulators can be connected to these relays without power amplifiers.

Some optical current and voltage sensors with electronic analog outputs offer the user the convenience of operating in a test mode generate 50 Hz or 60 Hz standard signals that can verify connections from the sensor to the relay and relay measurement accuracy. More details are provided in 9.2.

## **9.2 Testing inputs to relays with digital interfaces per IEC 61850-9-2-2004 [B15] process bus**

IEC 61850-9-2-2004 [B15] defines a mechanism for transmitting sample data streams from process equipment (such as voltage and current measurement equipment) to relays and other consumers of sampled data information, as shown in Figure 39.

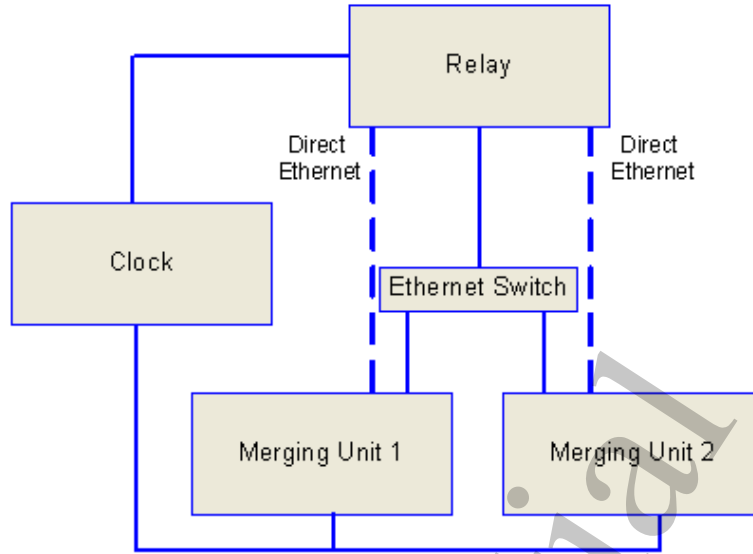

**Figure 39—Process bus test architecture overview for testing inputs with digital interface using GPS clock synchronization**

In this architecture, one or more MUs provide sampled data to the relay either through an Ethernet switch or through a direct Ethernet connection. The testing of this architecture requires the ability to inject the necessary streams of data into the Ethernet switch or directly into the relay. Figure 40 shows the test architecture where a test merging unit (TMU) is introduced. In this figure, the TMU is shown connected to the process bus Ethernet switch and is synchronized via the same clock used throughout the substation. In this example, the TMU must be capable of generating the multiple streams of sampled data required by the relay being tested. In the example shown, the TMU must be able to supply MU1 and MU2 data streams. Note that, alternatively, some test sets may be capable of generating sampled values that can be used in place of TMU sampled data streams. Note that sampled value streams are used instead of injection of analog secondary signals into the device under test.

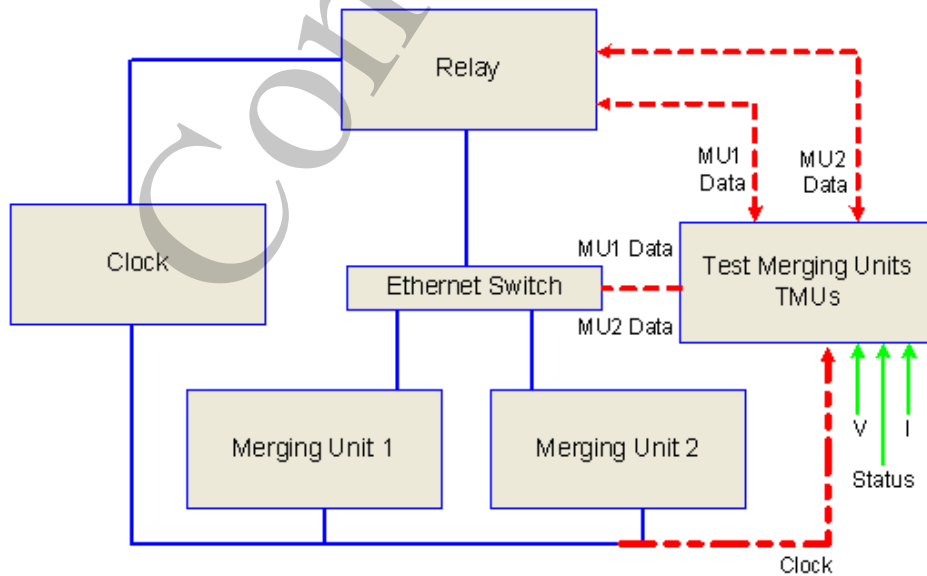

**Figure 40—Process bus test architecture using test merging units and GPS clock synchronization**

In general, testing can take three primary paths as discussed in 9.2.1 through 9.2.4.

### 9.2.1 Auxiliary TMU

In this test configuration, a set of spare MUs located in the control house (as shown in Figure 40) are connected to the relay either through an Ethernet switch or direct connected (as dictated by the implemented process bus architecture). Current, voltage, and status signals are then injected into the MU in the appropriate form (standard analog signals or low-level analog signals) and the TMUs then process the inputs and stream them accordingly to the connected relay under test (RUT). Note that the TMUs must be appropriately synchronized.

If mapped in the data set, the test bit in the quality flag shall be set—indicating to the RUT that the data being received are test data. If the RUT is also in test mode, it shall process the received data and provide protections and measurement values as if connected to the real system. Outputs to controls are to be executed as defined in IEC 61850.

### 9.2.2 PC-based test TMU

This path uses a standard PC either connected to the Ethernet switch or directly connected to the RUT (Figure 40). Note that in the latter configuration, the PC may be required to support multiple Ethernet ports/data streams to the RUT. The PC would either need to be able to play back stored waveforms or be able to generate and output the data streams dynamically as required by the RUT. An alternative to dynamic playback is the option of locally generating stored data files and playing back the generated files. As the PC has the ability to generate/play back synchronized data, the clock input to the PC is optional. Another method is the simulation of Sampled Values using test sets, described in 9.2.

Similar to the Auxiliary TMU option previously described, if mapped, the test bit shall be set and the RUT shall respond as defined in IEC 61850.

### 9.2.3 Primary/secondary injection

The third possible test mode is primary or secondary signal injection. In this mode of testing, a signal is injected either into the inputs of the existing MU or injected at the high-voltage interface of the process equipment.

When injecting into the secondary of the MU, a test set must be provided that can mimic the input type of the MU. In the case of an optical CT or PT, this signal is, by definition, an optical signal and requires special equipment. If the interface is through standard CT and PT interfaces, injection is possible through the use of standard test equipment; however, multiple synchronized test sets—located in the field—would be required to effect testing in this mode.

The capability of producing high-voltage signals is required when performing primary testing. See 9.2.4 for more details.

### 9.2.4 GOOSE testing

It should be noted that although the process bus is designed primarily for communication from a MU to a relay, there is a need to send control signals (e.g., breaker trip and close signals) from the relay to the MU. In this circumstance, it is logical that the IEC 61850 GOOSE mechanism be used over the same physical medium. GOOSE messages would contain status values that would be mapped into output contacts in the MU.

The RUT should provide a mechanism whereby each output in the MU can be exercised through the toggling of a bit in the transmitted GOOSE message. Outputs can be tested in the following two modes: “message received and executed” and “message received and noted.”

In the first mode of operation, an output bit is set in the GOOSE message, and it is observed that the respective output of the MU operates. Operation may be observed by actions such as a breaker actually opening or closing or the operation of an auxiliary relay.

In the second mode of operation, the test bit in the GOOSE is set. In this mode of operation, the test GOOSE is sent and the MU sets a sequence of events message to the effect that a test GOOSE was received for a particular output contact. The contact, however, is not operated. Refer to IEC 61850 for details.

### 9.3 Testing outputs of unconventional sensors

The standard method for verifying the accuracy of an unconventional sensor is the same as that used for conventional CTs and PTs—a primary injection test with accurate measurement of the output using accurate instruments or the relays and meters connected to its outputs. In general, such injection testing is used only during commissioning or apparatus-outage maintenance.

For a typical installation of an optical sensor, the optical losses of all fibers are measured along with the losses of the optical columns, using, for example, a handheld optical power loss meter. After connecting the fibers with the optical columns and the electronics, the losses are measured by means of the electronics itself. If both measurements are within acceptable levels, the unit is commissioned. Calibration is set at the factory, but a field recheck is conducted with primary injection as for a conventional CT.

Primary injection with some vendors’ optical current transformers may be easier than for conventional CTs. The effective transformation ratio of the optical CT can be changed onsite via software so that a lower primary current injection can be used to achieve target output signal levels. This allows testing the protection and instrument transformer together with more compact primary-source current generators.

Another testing advantage with some unconventional current sensors is that the measuring head has a window for the current-carrying power conductor rather than being a closed assembly—in some ways like a low-voltage window CT, even though the sensor is designed for operation at 765 kV ac or 800 kV dc. The position of the current conductor in the window has no effect on accuracy. For injection testing, a test primary can be created by winding several turns through the primary window, proportionally reducing the current required for the test.

For example, Figure 41 shows how a three-turn test primary is wound through the window of an EHV optical current sensor. The normal primary conductor need not be removed as long as it is isolated from the rest of the power system by breakers or disconnect switches (so that no other currents besides the test current can flow through the window).

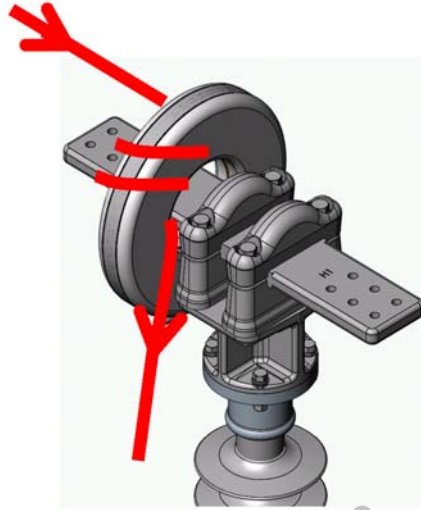

**Figure 41 —Three-turn test primary in window of current sensor**

Some unconventional sensors with electronic interfaces have a user access port that permits the user to read primary values, even if no relay or meter is connected. This is helpful for initial checks and for troubleshooting measurement problems.

Unconventional sensor technology provides tools for convenient independent calibration testing. Some of the technologies employed today include the following:

- Accurately wound fiber current sensors that can be safely installed on a live circuit as a portable calibration reference for a conventional or unconventional device to be verified.
- All-dielectric voltage sensors that can be safely elevated to contact a live circuit for a reference-accuracy voltage check.
- Line-mounted temporary high-precision current sensors that can be installed on a live circuit and communicates its reference measurements via a wireless network data link to a personal computer operating in the vicinity.

Subsystems of unconventional sensors can also be verified with procedures specified by the manufacturer of the particular sensor type.

Examples of test and maintenance features in commercial optical sensors are as follows:

- a) Self-monitoring of optical light levels, light source drive currents, internal chassis voltage levels, and temperatures. The parameters are logged automatically at startup for future comparison. These include automatic measurement of fiber cable length and optical losses of each channel. An alarm is raised for problems.
- b) Sensor electronics test mode generates an internal digital signal (50 Hz or 60 Hz) representing rated current or voltage. This data stream is passed through the sensor's analog-to-digital converter if the IEEE Std C37.92-2005 [B19] interface is used or through the MU interface if IEC 61850-9-2-2004 [B15] is used. The user checks the relay or meter reading to see if the rated secondary value is being received.
- c) Sensor electronics store trends of key sensor parameters for analysis.

## 9.4 Verification by condition-based maintenance

In a CBM program, the correct operation of the unconventional (or conventional) sensor and relay are observed as a system in a normal power system operation. This can be done if the measurements are read from relay metering displays or gathered by a data concentrator via a substation communications network and transmitted to SCADA and nonoperational maintenance centers. Control center or maintenance center computers compare relay and microprocessor-based device metered values with those originating from other sensors or instrument transformers and relays connected to the same power system quantities. Alternatively, the currents added around a bus can verify the measurement on a particular feeder, and remote voltages can be compensated to verify local values. A state estimator at the control center can report measurements with inconsistencies or gross errors.

A condition-based maintenance program covering unconventional sensors offers the following compelling advantages over periodic testing:

- a) Checks the whole relay and sensor system as an operating system.
- b) Avoids human intervention that could disrupt or disable a properly operating system.
- c) Reports failures as soon as they occur for quick repairs. If the utility depends only on periodic testing, then some failures will be found when a fault is incorrectly relayed before a scheduled test points out the failure.
- d) Saves the cost and outage for testing.

If the utility has installed PMUs or PMU-enabled relays, the precise synchrophasor values are particularly effective for spotting measurement errors in the sensors or instrument transformers supplying the signals from which they are computed.

New utility industry maintenance standards coming in the future are likely to recognize CBM as a legitimate maintenance program that reduces the need for periodic time-based field testing by technicians.

Confidential

## Annex A

(informative)

### Bibliography

[B1] ANSI C93.1-1999, American National Standard Requirements for Power-Line Carrier Coupling Capacitors and Coupling Capacitor Voltage Transformers (CCVT).<sup>6</sup>

[B2] ANSI C93.4-1984, American National Standard for Power-Line Carrier Line-Tuning Equipment.

[B3] ANSI C93.5-1997, American National Standard Requirements for Single Function Power-Line Carrier Transmitter/Receiver Equipment.

[B4] CIGRÉ Working Group 12.09, Thermal Aspect of Transformers, “A Survey of Facts and Opinion on the Maximum Safe Operating Temperatures under Emergency Conditions,” Paris, 1995.

[B5] CIGRÉ Working Group 12.09, Thermal Aspect of Transformers, “Survey of Power Transformer Overload Field Practices,” No. 161, 1995.

[B6] CIGRÉ Working Group 34.10, “Analysis and Guidelines for Testing Numerical Protection Schemes,” 2000.

[B7] Das, R., “Real-Time Simulation for Relay Performance Evaluation,” *Proceedings of the IEEE Power System Conference and Exposition (PSCE)*, New York City, October 10–13, 2004.

[B8] Elmore, W. A., *Applied Protective Relaying*. St. Louis, MO: ABB Power T&D Company, 1994.

[B9] IEC 60044-7-1999, Instrument Transformers—Part 7: Electronic Voltage Transformers (also see IEC 60044 set).<sup>7</sup>

[B10] IEC 60044-8-2002, Instrument Transformers—Part 8: Electronic Current Transformer (see also IEC 60044 set).

[B11] IEC 60834-1-1999, Teleprotection Equipment of Power Systems, Performance and Testing—Part 1: Command Systems.

[B12] IEC 61850-4-2002, Communication Networks and Systems in Substations—Part 4: System and Project Management.

[B13] IEC 61850-6-2004, Communication Networks and Systems in Substations—Part 6: Configuration Description Language for Communication in Electrical Substations Related to IEDs.

[B14] IEC 61850-8-1-2004, Communication Networks and Systems in Substations—Part 8-1: Specific Communication Service Mapping (SCSM)—Mapping to MMS (ISO 9506-1 and ISO 9506-2) and to ISO/IEC 8802-3.

---

<sup>6</sup> ANSI publications are available from the Sales Department, American National Standards Institute, 25 West 43rd Street, 4th Floor, New York, NY 10036, USA (<http://www.ansi.org/>).

<sup>7</sup> IEC publications are available from the Sales Department of the International Electrotechnical Commission, Case Postale 131, 3 rue de Varembe, CH-1211, Genève 20, Switzerland/Suisse (<http://www.iec.ch/>). IEC publications are also available in the United States from the Sales Department, American National Standards Institute, 11 West 42nd Street, 13th Floor, New York, NY 10036, USA.



[B15] IEC 61850-9-2-2004, Communication Networks and Systems in Substations—Part 9-2: Specific Communication Service Mapping (SCSM)—Sampled Values Over ISO/IEC 8802-3.

[B16] IEEE PSRC Committee Report, “Summary update of practices on breaker failure relaying,” *IEEE Transactions on Power Apparatus and Systems*, vol. PAS-101, no. 3, pp. 555–563, Mar. 1982.

[B17] IEEE Std C37.2™-2008, IEEE Standard for Electrical Power System Device Function Numbers, Acronyms, and Contact Designations.<sup>8,9</sup>

[B18] IEEE Std C37.91™-2008, IEEE Guide for Protecting Power Transformers.

[B19] IEEE Std C37.92™-2005, IEEE Standard for Analog Inputs to Protective Relays from Electronic Voltage and Current Transducers.

[B20] IEEE Std C37.94™-2002 (Reaff 2008), IEEE Standard for N times 64 Kilobit per Second Optical Fiber Interfaces between Teleprotection and Multiplexer Equipment.

[B21] IEEE Std C37.102™-2006, IEEE Guide for AC Generator Protection.

[B22] IEEE Std C37.103™-2004, IEEE Guide for Differential and Polarizing Relay Circuit Testing.

[B23] IEEE Std C37.104™-2002 (Reaff 2008), IEEE Guide for Automatic Reclosing of Line Circuit Breakers for AC Distribution and Transmission Lines.

[B24] IEEE Std C37.109™-2006, IEEE Guide for the Protection of Shunt Reactors.

[B25] IEEE Std C37.111™-1999, IEEE Standard for Common Format for Transient Data Exchange (COMTRADE) for Power Systems.

[B26] IEEE Std C37.113™-1999, IEEE Guide for Protective Relay Applications to Transmission Lines.

[B27] IEEE Std C37.115™-2003, IEEE Standard for Standard Test Methods for Use in the Evaluation of Message Communications Between Intelligent Electronic Devices in an Integrated Substation Protection, Control and Data Acquisition System.

[B28] IEEE Std C37.231™-2006, IEEE Recommended Practice for Microprocessor-Based Protection Equipment Firmware Control.

[B29] IEEE Working Group K3 (Transformer Thermal Overload Protection), “Adaptive transformer thermal overload protection,” *IEEE Transactions on Power Delivery*, vol. 16, no. 4, pp. 516–521, Oct. 2001.

[B30] Jodice, J. and Harpham, S., “End-to-end transient simulation for protection system performance testing,” *Developments in the Use of Global Positioning Systems*, pp. 6/1–6/5 London, Feb. 8, 1994.

[B31] Lahoti, B. D. and Flowers, D. E., “Evaluation of transformer loading above nameplate rating,” *IEEE Transactions on Power Apparatus and Systems*, vol. PAS-100, no. 4, pp. 1989–1998, Apr. 1981.

[B32] Mozina, C., et al., “Commissioning and maintenance testing of multifunction digital relays,” *IEEE Industrial and Commercial Power Systems Technical Conference*, pp. 82–91, May 2–6, 2004.

---

<sup>8</sup> IEEE publications are available from the Institute of Electrical and Electronics Engineers, 445 Hoes Lane, Piscataway, NJ 08854, USA (<http://standards.ieee.org/>).

<sup>9</sup> The IEEE standards or products referred to in this clause are trademarks owned by the Institute of Electrical and Electronics Engineers, Incorporated.

[B33] North American Electric Reliability Corporation (NERC):  
[ftp://www.nerc.com/pub/sys/all\\_updl/standards/rs/PRC-005-1.pdf](ftp://www.nerc.com/pub/sys/all_updl/standards/rs/PRC-005-1.pdf).

[B34] North American Electric Reliability Corporation (NERC):  
[ftp://ftp.nerc.com/pub/sys/all\\_updl/pc/spctf/Relay\\_Maintenance\\_Tech\\_Ref\\_approved\\_by\\_PC.pdf](ftp://ftp.nerc.com/pub/sys/all_updl/pc/spctf/Relay_Maintenance_Tech_Ref_approved_by_PC.pdf).

[B35] Schreiner, Z. and Kunter, R., Remote Controlled Testing of Communication Schemes for Power System Protection Using Satellite (GPS) Synchronization and Modern Communication Technology: A New Approach. Houston, TX: Omicron Electronics, 2001. <http://www.omicron.at/en/literature-videos/papers/>.

[B36] Thompson, M., "Fundamentals and advances in breaker failure protection," *53rd Annual Georgia Tech Protective Relaying Conference*, Atlanta, GA, May 5–7, 1999.

[B37] Tziouvaras, D., et al., "The effects of conventional instrument transformer transients on numerical relay elements," *Proceedings of Western Protective Relay Conference WPRC 01*, Spokane, WA, Oct. 23–25, 2001.

[B38] Zocholl, S. E. and Guzman, A., "Thermal model in power system protection," *Proceedings of Western Protective Relay Conference WPRC 99*, Spokane, WA, Oct. 25–28, 1999.

Confidential

## Annex B

(informative)

### Suggested line current differential scheme testing procedure

#### *Current differential (87L) channel monitoring*

Once the communication channel(s) is supplied to the relay, the following has to be checked in the relay diagnostic menu:

- The channel status should be continuously healthy. Interruptions in the channel indicate a problem with a channel and have to be investigated. Possible problems might include inadequate *received* signal level, loose connections, and communication noise. Communication noise is quantified by bit error ratio (BER) and can cause corruption of the 87L packet, potentially leading to 87L misoperation. Generally, a channel with BER less than  $1 \times 10^{-4}$  is considered appropriate for the 87L application.
- An important indication of channel health is the lost packet count. Packets can be lost due to corruption because of the noise, channel switching, or channel fading; packets can also be lost if clocking of the communication system is not configured properly. If there is an increase, it indicates that channel is not healthy—this has to be further investigated and addressed.
- Protection 87L function should be fully enabled.
- Channel delay should be steady and within reasonable margin. Typically, a multiplexed channel can introduce 2 ms through 12 ms (sometimes even more) of the external round-trip delay compared to a dedicated fiber channel.
- Channel asymmetry can be checked by injection of 1 per unit through current using GPS synchronized test sets and monitoring the differential current. A differential current close to zero indicates that there is no channel asymmetry on that particular channel. Maximum possible asymmetry has to be determined by creating worst-case communication path on the SONET/SDH ring and measuring differential current again. Channel asymmetry checks are not required in direct, single-fiber channel applications.

All channel-related problems have to be solved in coordination with the communications department.

At one terminal, a communication channel has to be interrupted by temporarily removing/replacing, for a short period of time, either the fiber connector or just the wire in case of galvanic interface. The relay records should be checked to indicate channel interruptions, possible lost or corrupted packets count, disabling and then enabling of the differential enabling, and disabling of the backup protection. The timing should be checked in accordance with the manufacturer's specifications. When a redundant channel is involved, timing to switch from main to backup communications path and vice versa should be checked. Some relays operate in a primary-hot standby mode while others operate in a primary-alternate mode. Appropriate tests have to be performed according to the design.

Verification of the relay ID is generally performed; relays applied over multiplexed channels are usually programmed to check whether the packets are received from the correct device. This eliminates misoperations when the channel is inadvertently looped back and the relay is measuring twice as much differential current as expected. By changing the ID temporarily to a "wrong" one, a check is performed to determine whether the relay's 87L function is blocked.

*87L blocking*

When this feature is used, the following two types of blocking elements may be applicable to 87L relaying:

- a) The entire 87L protection system is taken out of service or returned to service after maintenance or troubleshooting. Testing should confirm that if at any terminal, block signal is applied to the 87L relay, current injection is above pickup set point of the relay and the relay does not produce a differential trip.
- b) When the 87L protection system is applied in a dual-breaker configuration (breaker-and-a-half or ring bus) and a line disconnect switch is open, it creates a so-called “stub bus” zone. The local 87L relay blocking element stops transmission of phasor quantities. As illustrated in Figure B.1, when the line disconnect switch is open at the Station A but both breakers are still closed, thus maintaining power exchange between Station A buses, a stub bus zone between the breakers and the disconnect switch is created. Although the stub bus zone is not part of the line anymore but rather is an element of the bus, it has to still be protected by either line protective relay or some auxiliary relay energized for this condition only. During normal power flow between two buses, the currents through both breakers are placed in opposite directions and cancel each other out ideally to zero in the relay. If, however, a fault occurs in the stub bus zone, the sum of the two currents is not equal to zero anymore. If care is not taken to force transmitted current to zero, then erroneous differential current can cause tripping by remote relay(s).

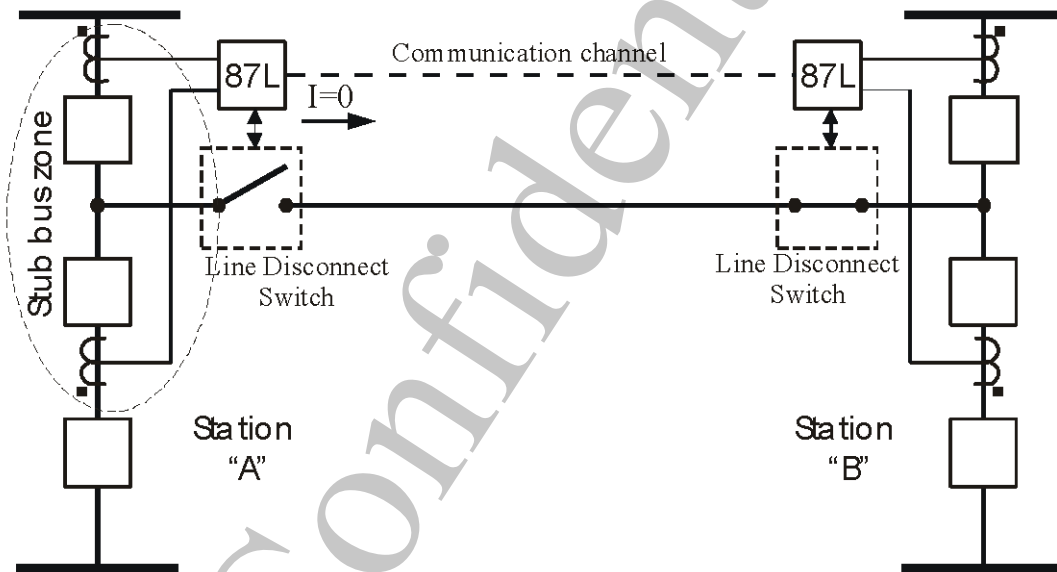

**Figure B.1—Stub bus and 87L relaying**

Typically, current differential relays have provisions to stop phasor transmission to a remote end once line disconnect switch is open, to block local relay differential element, and to enable stub bus protection providing tripping for stub bus zone breakers only, when a fault occurs in the stub bus zone.

The testing for stub bus condition should confirm that, once the line disconnect switch is open, any injection in this relay is not causing either remote or local relay differential operation. On the other hand, it should also confirm that stub bus protection becomes active and provides fault clearing by tripping local breakers.

### *87L differential characteristics*

Once the 87L channel(s) has been tested successfully and is in service, 87L relay operation can be tested. Using GPS synchronized test sets, a multiple of pickup of continuous through three-phase/one-phase current is applied to both relays, for example, 5× pickup. In case of three-terminal line, 10× pickup of infeed current at one terminal and 5× pickup of outfeed current at two other relays can be applied. Basically, a minimum of four points of differential characteristics have to be captured, as follows:

- Maintaining the same current at one terminal 87L relay, the current at another terminal is reduced until relays at all terminals operate. The operating values are recorded and currents are returned back to the initial values.
- Maintaining the same current at one terminal 87L relay, the current at another terminal is increased until relays at all terminals operate. The operating values are recorded and currents are returned back to initial values.
- Maintaining the same current at one terminal 87L relay, the angle of the current at another terminal is increased until relays at all terminals operate.
- Maintaining the same current at one terminal 87L relay, the angle of the current at another terminal is decreased until both relays at all terminals operate.

Captured operating points of differential characteristics are checked against manufacturer published characteristics or equations, and appropriate circuit breaker tripping operation is verified when test points enter the operating region of the 87L characteristics. If required, the operating times of 87L relay can be monitored and recorded.

### *87L through fault security*

Using GPS synchronized test sets, a multiple of pickup (for example, 10× pickup) of continuous through three-phase/one-phase current is applied to both relays. In the case of a three-terminal line, 10× pickup of infeed current at one relay and 5× pickup of outfeed current at two other relays can be applied. The differential current observed should be literally zero. The relay's percent differential restraint is checked to be in accordance with manufacturer specifications for a given injection and settings. Then, the angle at one relay carrying 10× pickup current is increased to the point when differential operates checked to find an edge between operate and restraint zones. The angle is pulled back by 10° into the restraint zone, and then the channel(s) is broken/reconnected several times to verify that each relay's differential operation occurs. Relay records should show a channel failure leading to an 87L block and then enabling differential back in service without any operation.

Transient simulations are often performed when the line differential performance, under CT saturation, infeed/outfeed conditions, and so on, is a concern.

### *87L internal fault dependability*

Similar to the test above, the same test values would be applied but for the solid internal fault when all currents are in phase. The differential current observed should be high, 20× pickup current, for example. Percent differential relays restraint is checked to be according to manufacturer specifications for a given injection and settings. Then, the angle at one relay carrying 10× pickup current is increased to the point when differential drops off. The angle is pulled back by 10° into the restraint zone, and then the channel(s) is broken/reconnected several times to verify that each relay's differential operation is performing correctly. Relay records should show channel failure leading to 87L operation; the timing is measured by how long it takes to bring the 87L into service and operate.

### *87L minimum pickup and timing*

A three-phase/single-phase current is injected into one relay and is increased until all the 87L relays operate. The pickup current would then be compared with the manufacturer's specifications. Then the three-phase/one-phase current  $5\times$  pickup is injected into only one relay and the operating time is measured.

### *87L direct transfer trip*

When such a feature is available, typically 87L differential relays operate simultaneously at all terminals of the protected line, as all of them measure the same differential current. However, a differential channel can be used to send a DTT signal from external breaker failure relay (as an example). Another important consideration is a three-terminal (or multiterminal) system when a communication path is broken between two peers. In such case, relays not having a complete phasor set of data due to channel failure are blocked. However, the relay, which has all channels intact, is still capable of making a differential decision and sending a DTT to peer relays. Therefore, it is important to test that DTT is getting through to the remote end(s) when it is configured to do so.

### *87L supervision*

Traditionally, 87L functions were supervised by the fault detector to ensure that operation did not occur as a result of channel impairments, such as packet corruption (due to noise, data misalignment, etc.). Usually, a current disturbance detector was used for that purpose. In some cases, such as weak-infeed terminal, supervision may prevent a differential trip. This can be overcome by supervising 87L function from either a local disturbance detector or received from the peer 87L relay over communication channel using direct relay-to-relay bits. Such an approach is also beneficial for DTT.

### *87L and single-pole tripping*

When the 87L relay is applied for single-pole tripping, tripping and reclosing functionality has to be additionally checked. Particularly, for the SLG fault, the faulted phase should be only tripped. If the 87L relay is using current sequence-components for differential function, then elements using these components should be blocked in a timely manner. When a fault evolves from SLG to LLG or when a 3PH fault is detected, then a three-pole trip should be initiated with possible blocking of the auto reclosure. Everything but SLG faults should be causing three-pole tripping operations.

### *87L on-load tests*

It is common practice to put the 87L device in service after the on-load check. Reading of the local terminal phase currents, remote terminal(s) phase currents, and differential currents in all three phases should agree with metering from other devices and expected values. The differential current should be equal to the line charging current compensated by shunt reactors.

If charging current compensation is applied in the 87L relay, then compensated charging current should be significantly less and in accordance with manufacturer specifications. Typically, overhead transmission lines between 230 kV and 345 kV exhibit 0.7 A to 1.4 A of primary charge current per mile; for underground cables, these values might be seven to ten times greater. When shunt reactors are used on the line, the expected charging current value is reduced. The expected steady-state differential current value can be estimated by using the following formula:

$$I_{\text{diff}} \approx \frac{V_N}{\sqrt{3} \cdot (X_{C1} - X_{R1})}$$

where

$V_N$  is the line nominal phase-to-phase voltage.

$XC_1$  is the line total positive-sequence shunt capacitive reactance.

$XR_1$  is the total inductive reactance differential zone.

The differential current above the expected value indicates problems associated with either the CT circuitry, ratio matching, or channel asymmetry present on the communication link.

Confidential

## Annex C

(informative)

### Impact of high-impedance faults to protective relay performance and system testing

Fault impedance can be approximated by two different formulas:

where  $l$  is the arc length in meters and  $I$  is a current in amperes in the arc.

where  $l$  is the arc length in feet and  $I$  is a current in amperes in the arc.

Actual arcs are variable, tending to start at a low value, build up to a high value, and then break over, returning to a lower value of resistance. Tower footing resistance is also variable, which can range from 1  $\Omega$  to several hundred ohms. Many studies were carried out over the years on wet soil, rocks, asphalt, concrete, and so on with variable and unpredictable results. Thus, with so many variables, common practice is to neglect tower footing resistance in fault studies and to assume fault arc resistance being purely resistive.

Traditionally, zero-sequence and negative-sequence components of the currents and voltages not affected by the load current were used to detect high-impedance faults. Setting such protection too sensitive may expose ground protection to misoperations because, due to the unbalance in the phase currents and voltages, distortions in the phase currents and voltages due to harmonics, off-nominal frequency conditions, CT saturation, and so on. Therefore, in performance testing, sensitivity of protection setpoints between fault resistance coverage, and security for distorted waveforms during high-fault current should be evaluated.

*Solid grounding* is usually used on the utility subtransmission and transmission systems 69 kV and up. Magnitude of the ground fault vary with fault location and is typically enough to apply different types of protection. *Ungrounded, resonant grounded, and high-impedance grounded* systems are employed for utility distribution and industrial service 33 kV and below where high-service continuity is required. Ground fault current may be less than 10 A primary, which makes locating the ground faults a difficult task.

One of the elements included in performance evaluation of line protective devices is fault location. Fault currents during SLG faults are capacitive and depend on the phase to ground capacitance of the whole network supplied from distribution transformer(s).

*Low-impedance grounding* typically limits the ground fault current to 50 A to 600 A. The faults can be classified, in terms of fault resistance, as follows:

- a) *Low resistance*, when the primary value of fault resistance is less than 10  $\Omega$ .
- b) *Medium resistance*, when the primary value of fault resistance is less than 50  $\Omega$  but greater than 10  $\Omega$ .
- c) *High resistance*, when the primary value of fault resistance is greater than 50  $\Omega$ . Some regulations may entail a direct requirement for sensitivity for the ground fault (e.g., the ability to detect ground fault of 600 A primary).



The protection has to be selected based on such requirement and system impedances. The following types of protection are used to detect ground faults:

- Negative-sequence and zero-sequence TOC and instantaneous overcurrent, which is usually used as a primary protection on distribution feeders and as a backup protection on the transmission systems for ground faults. This type of protection can be made directional by directional zero or negative elements and can typically detect low-resistance and sometimes medium-resistance faults. Due to coordination between adjacent lines, it does not allow for a sensitive setting. This method is used on solidly grounded or low-impedance grounded systems. The limits of sensitivity can be easily estimated analytically or by fault studies and proved by testing. When directional elements are used, they should be confirmed by fault studies that there is enough polarizing quantity for the protected zone coverage during a high-resistance fault.
- Ground distance with quadrilateral characteristic is typically able to detect low-resistance ground faults. Usually, resistive reach is not recommended greater than three to five times the reactive reach so as to prevent overreaching due to a possible shift of the line reactance during an external high-resistance fault. For short lines, distance resistive coverage is inherently limited. Ground distance is used primarily on the solidly grounded and sometimes on the low-impedance grounded systems. The line reactance can be polarized by zero-sequence, negative-sequence, or phase current. Depending on the relay and distribution of the zero-sequence and negative-sequence current, high-resistance faults superimposed on the load current may expose relay to overreaching or underreaching effects.

The apparent impedance seen by the relay is as follows:

$$Z_{APP} = \frac{V_A}{I_{AG}} = m \times Z_{1L} + R_F \times \frac{I_F}{I_{AG}}$$

The  $mZ_{1L}$  term is a measure of the distance, and the  $R_F \times \frac{I_F}{I_{AG}}$  is an error term or the added “fault impedance” as explained in Figure C.1.

The physical fault resistance is amplified in the apparent impedance equation if the local current is lower than the total fault current at the fault point ( $\left| \frac{I_F}{I_{AG}} \right| > 1$ ). Under a strong remote terminal and weak sourced local terminal, the physical fault resistance may be amplified considerably.

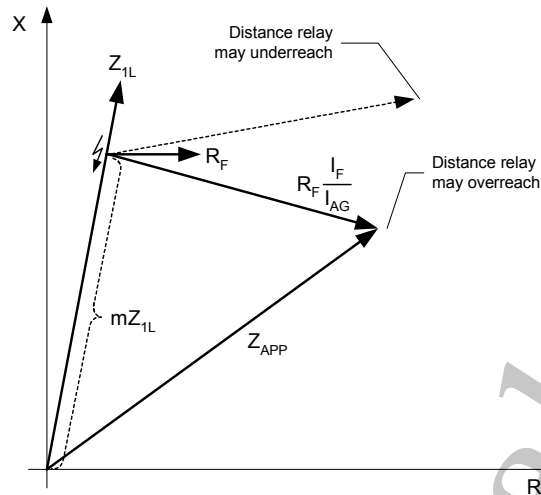

**Figure C.1—Impact of the added fault impedance on effective relay reach**

Real-time simulations, short-circuit fault studies, or transient programs are all recommended tools to generate test cases for ground distance function performance during resistive faults.

A line current differential is capable of detecting high-resistance faults with a typical differential pickup setting of 0.2 p.u. The limit of resistive coverage is dictated by the value of the fault current supplied by an equivalent source during such fault. The benefit of this protection is that all terminals contribute to differential current and increasing sensitivity of protection. As the value of resistive fault currents is easily available from the short-circuit studies, testing is easy to perform with the test set(s). Attention should be paid to the case when the line is energized from one end only.

A line phase comparison is also capable of detecting high-resistance faults. The limit of resistive coverage is dictated by the ability to set the fault detectors above the load current. These considerations are similar to the line current differential above.

Pilot schemes can be set most sensitive using negative-sequence or zero-sequence directional elements. An advantage of this protection is that no coordination is needed between adjacent lines; however, for a specific blocking scheme, coordination is required for peer relays at the opposite ends of the line. Reverse-looking element at one end should be more sensitive (typically, 2–3 times lower than forward-looking element at the opposite end of the line). As it was mentioned above, these directional elements may be exposed to malfunctions during high-fault currents leading to CT saturation. To secure protection, it is possible to use two sets of directional elements, one set being more sensitive for low-fault currents and the other being more sensitive responding to high-fault currents. During the high-fault current, the most sensitive directional element is blocked. Testing of the pilot scheme requires synchronous injection of the fault quantities at all terminals of the line. Because of that, using GPS synchronized test sets with prerecorded resistive faults waveforms (COMTRADE files) is the preferred way of testing. Attention should be paid in the case when the line is energized from one end only and when at least one terminal is weak.

Sensitive zero-sequence power (watt-metric) is used on the isolated, compensated, or high-impedance grounded systems to detect ground faults. The magnitude of the resistive ground fault current depending on the network capacitance, neutral arrangement, and value of fault resistance has to be evaluated analytically or with a short-circuit program. As usual, the magnitude of the fault current is small, but testing should confirm that the relay has enough sensitivity for such currents, and it should determine resistive ground faults correctly.

## Annex D

(informative)

### Transformer oil and winding temperature computational methods

The instantaneous evolution of the winding hot-spot temperature at the top or in the center of the high- or low-voltage winding of a power transformer can be estimated by solving the analytical model described in IEEE Std C57.91. The transformer loading guidelines are also described in Lahoti and Flowers [B31] and IEEE Working Group K3 [B29].

The simplifying assumptions adopted in the formulation of such a model are as follows:

- The oil temperature profile inside the winding increases linearly from bottom to top.
- The difference between the winding temperature and the oil temperature is constant along the winding.
- The hot-spot temperature rise is higher than the temperature rise of the conductor at the top of the winding, introducing a conservative correction factor.
- The ambient temperature drives the oil temperature up and down with the same time constant as the winding temperature does.
- The solar flux incidence is neglected.

Such assumptions led to the adoption of the temperature profile inside the transformer, as depicted in Figure D.1.

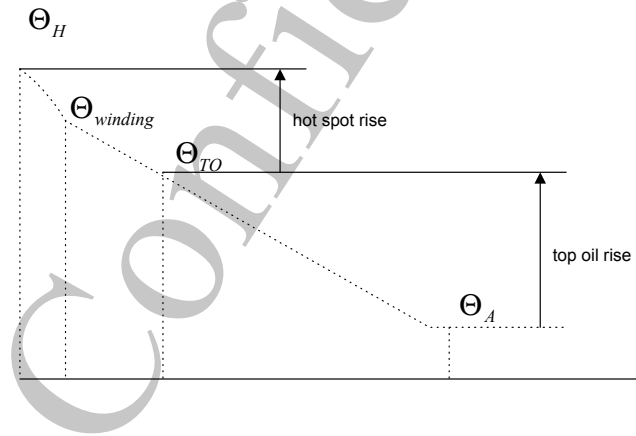

**Figure D.1—Temperature profile assumed in the IEEE loading guide**

Once these assumptions are made, the hot-spot temperature can be calculated as the sum of two components, the top oil temperature and the hot-spot rise above top oil temperature, as expressed in the following equation:

$$\Theta_H = \Theta_{TO} + \Delta\Theta_H \quad (D.1)$$

As reported by IEEE Working Group K3 [B29], the evolution of such variables can be estimated by the following physical model:

$$\begin{cases} \tau_{TO} \frac{d\Theta_{TO}}{dt} = [\Delta\Theta_{TO,U} + \Theta_A] - \Theta_{TO} \\ \tau_H \frac{d\Delta\Theta_H}{dt} = \Delta\Theta_{H,U} - \Delta\Theta_H \\ \Delta\Theta_{TO,U} = \Delta\Theta_{TO,R} \left[ \frac{I_L^2 R + 1}{R + 1} \right]^{e_2} \\ \Delta\Theta_{H,U} = \Delta\Theta_{H,R} I_L^{2e_1} \end{cases}$$

where

- $\Theta_A$  is the ambient temperature, °C
- $\Theta_{TO}$  is the top oil temperature, °C
- $\Theta_H$  is the hot-spot winding temperature, °C
- $\Theta_{H,R}$  is the rated hot-spot winding temperature, °C
- $\Delta\Theta_H$  is the hot-spot temperature rise above top oil, °C
- $\Delta\Theta_{TO,U}$  is the ultimate top oil temperature rise, °C
- $\Delta\Theta_{TO,R}$  is the rated top oil temperature rise over ambient, °C
- $\Delta\Theta_{H,U}$  is the ultimate hot-spot temperature rise over top oil (for a given load current), °C
- $\Delta\Theta_{H,R}$  is the rated hot-spot temperature rise over top oil (for rated load current), °C
- $\tau_{TO}$  is the top oil rise-time constant, h
- $\tau_H$  is the hot-spot rise-time constant, h
- $I_L$  is the load current normalized to rated current, p.u.
- $R$  is the ratio of rated-load loss to no-load loss at applicable tap position
- $e_1, e_2$  are the two empirically derived exponents, dependent on the cooling method

## Annex E

(informative)

### Measuring and compensating for time delay after trigger for performing end-to-end testing using different relay test sets

Using different types of relay test sets is possible. Test equipment produced by different vendors may have different time delays after trigger. Therefore, the pre-fault time period may be different. To ensure that the triggering of fault injections is properly coordinated, the post-trigger time delay of relay test sets must be accurately measured prior to the actual end-to-end test. The difference in time durations must be factored in the synchronization of secondary data injections.

It is important to note that the delay time after trigger for state sequence playback and for DFR playback may vary for different test equipment manufacturers.

Simultaneous secondary injections are accomplished by synchronizing the event triggers on the relay test sets using GPS satellite clock receivers (Figure E.1). The GPS clock receivers, with programmable trigger outputs, are programmed to trigger the relay test sets within a microsecond of each other. This provides the synchronized outputs of multiple relay test sets at terminals that can be hundreds of miles apart.

Once the trigger pulse is received, the relay test set has to process the signal in order to activate the analog outputs (V, I). Each vendor has different electronic components and algorithms to process the received signal. This difference causes the signal to be processed differently between vendors.

The difference in time durations (compensation time) must be factored in the synchronization of secondary data injections.

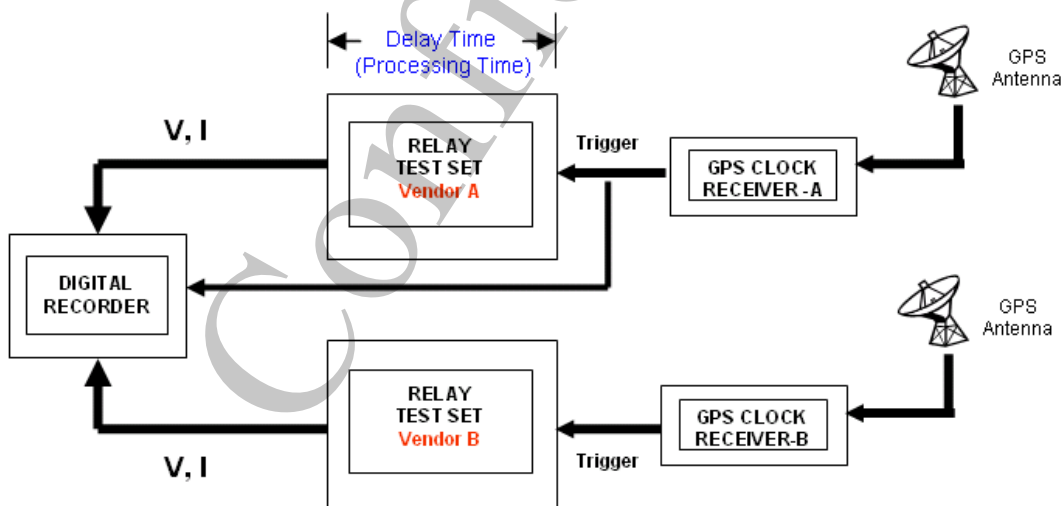

**Figure E.1—Setup for measuring the delay time after trigger**

In order to define the compensation time between two different relay test set vendors, a digital recorder tool such as an oscilloscope, a digital fault recorder, a digital relay, or equivalent is required. Figure E.1 shows a proposed setup to measure the delay time after trigger prior to the actual end-to-end test.

In this test setup, a state sequence is preloaded into each relay test set. An agreed time is entered into the GPS clock receiver of each vendor. When the event trigger time arrives, the GPS clock receivers trigger the relay test sets to initiate the pre-fault injection into the digital recorder.

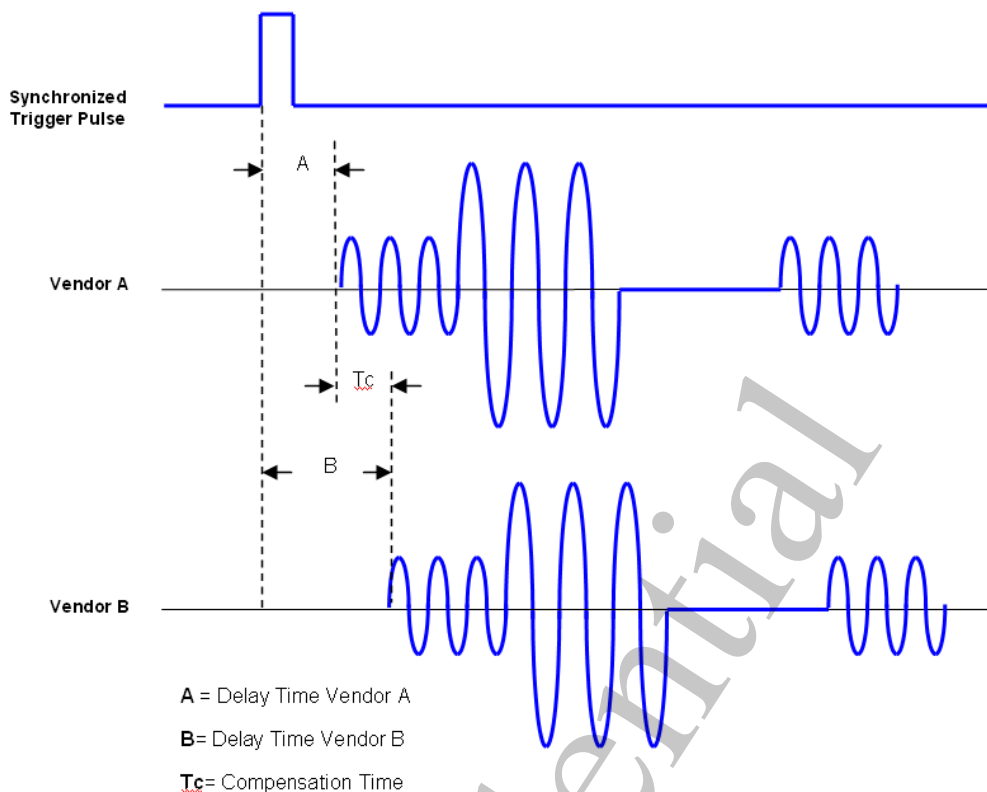

**Figure E.2—Data from digital recorder**

Figure E.2 shows an oscillographic record that can be saved using a digital recorder. The record shows the difference in time delay after trigger between the two relay test sets, which can be calculated as follows:

$$T_c = |A - B|$$

T<sub>c</sub> may be different for state sequence playback and for DFR playback due to differences in the algorithm of each vendor. It is recommended to execute this test for either state sequence or DFR playback.

There are two methods to correct for this difference in time. One is to add T<sub>c</sub> onto the prefault time delay of the test set with the shortest delay after trigger so that the faults from both units occur approximately at the same time. The other method is to adjust the trigger time programmed in the GPS receivers by subtracting T<sub>c</sub> to the test set with the longest delay after trigger.

In order to illustrate these two methods, consider the following data:

Prefault time vendor A = 128 ms

Prefault time vendor B = 128 ms

Trigger vendor A @ 12:00:00:000

Trigger vendor B @ 12:00:00:000

Using the digital recorder, the delay time after trigger for the two test sets was determined to be as follows:

A = 23.7 ms

B = 32 ms

T<sub>c</sub> = 8.3 ms

Using the first method, 8.3 ms should be added to the prefault time of vendor A in order to ensure that the triggering of fault injections is properly coordinated. The new values will be as follows:

Prefault time vendor A = 136.3 ms

Prefault time vendor B = 128 ms

Trigger vendor A @ 12:00:00:0000

Trigger vendor B @ 12:00:00:0000

Using the second method, 8.3 ms should be subtracted from the trigger time of vendor B in order to ensure that the triggering of fault injections is properly coordinated. The new values will be as follows:

Prefault time vendor A = 128 ms

Prefault time vendor B = 128 ms

Trigger vendor A @ 12:00:00:0000

Trigger vendor B @ 11:59:59:9917

Confidential